

SEW
EURODRIVE

PRODUCTS SOLUTIONS

2015

Our drive is to set the world in motion

Does this sound familiar? It starts with just a thought, which then grows and develops into an idea. The idea sets things in motion, makes things happen – and, with enough commitment, innovation and courage, it eventually becomes a reality. You're sure to be familiar with this process – we certainly are.

Getting things moving has been at the heart of our company ever since it was established in 1931. This is still the case today – even more so, in fact, now that the world is changing faster than ever. For over 80 years now, SEW-EURODRIVE has been committed to following two important paths. The path of innovation and the path of our philosophy for driving the world. Networking knowledge and technology, humans and machines, and products and expertise in an intelligent and sustainable process creates synergies you can benefit from every single day. We put our experience in product solutions and drive systems to good use all over the world.

Our drive is to set the world in motion – using solutions that are tailored specifically to your requirements and expectations. This is what **Driving the world** is all about. We are your partner – we are on your level. We deliver precisely the services, solutions and products you need to drive your company forward.



Jürgen Blickle
Managing Partner



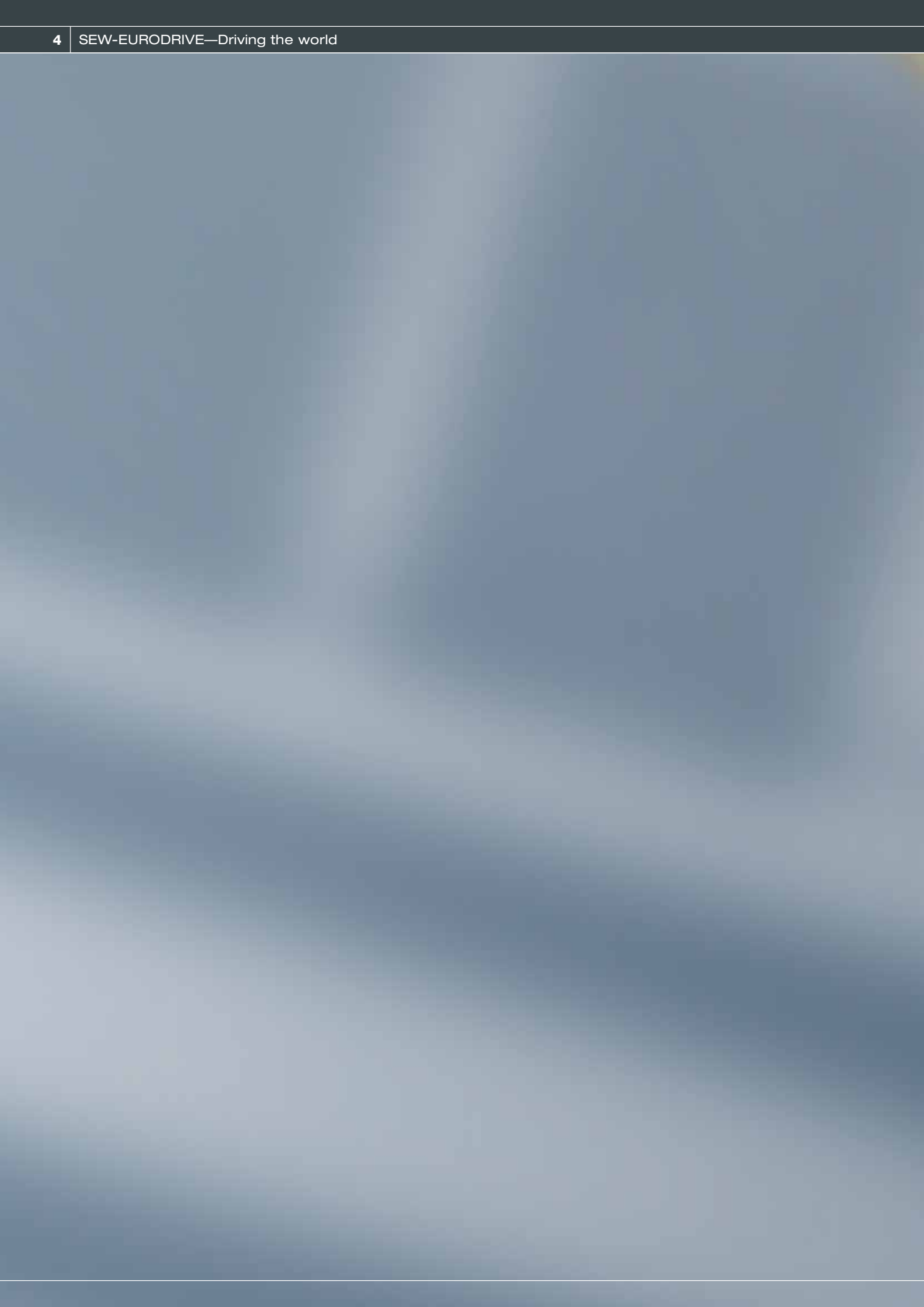

DRIVING THE WORLD

YOUR BENEFITS	8
YOUR PARTNER	12
YOUR SUCCESS	20

SERVICES

VALUE CREATION	28
DRIVE BENEFITS	30
ONLINE SUPPORT	40

SOLUTIONS

PREDEFINED SOLUTIONS	46
TAILORED SOLUTIONS	50
SOLUTIONS WITH INDUSTRIAL GEAR UNITS	54

PRODUCTS

01 GEAR UNITS	62
02 GEARMOTORS	82
03 MOTORS	102
04 INDUSTRIAL GEAR UNITS	144
05 DECENTRALIZED DRIVES / MECHATRONICS	160
06 INVERTER TECHNOLOGY	178
07 SERVO DRIVE TECHNOLOGY	220
08 INDUSTRIAL COMMUNICATION	268
09 CONTROL TECHNOLOGY	280
10 OPERATION AND STARTUP	292
11 SAFETY TECHNOLOGY	304
12 CONTACTLESS ENERGY TRANSFER SYSTEM	312
13 DIDACTICS MODULES	318

DRIVING THE WORLD

**A FAMILY BUSINESS
ON A GLOBAL SCALE**

YOUR BENEFITS

STANDSTILL IS NOT AN OPTION – WE ALWAYS KEEP THINGS MOVING
ALWAYS FOCUSED ON YOUR BENEFITS.

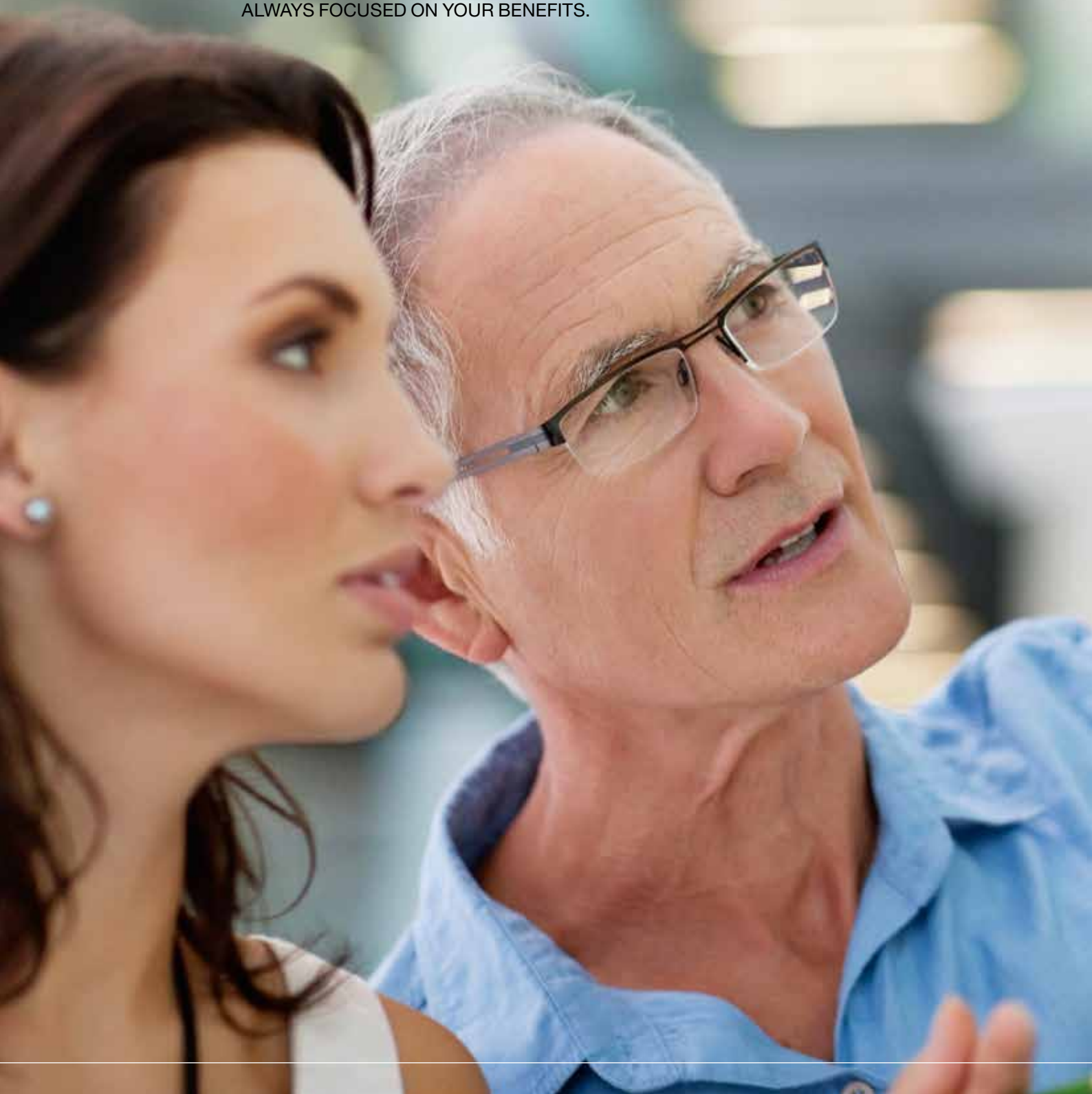



Your benefits – many solutions, one reliable partner.

Keeping things moving – this is the principle we work by at all times and in all locations and is what drives our success. You are the people best placed to know what makes you successful. And you also know that SEW-EURODRIVE delivers real added value. So why is it worth investing in our company, our drive technology and our services?

Because our flexibility drives your company's growth.

It's quite simple – anyone who can respond to fast-paced delivery schedules, cost pressure and increased capacity demands in a fast and individualized way is clearly at an advantage. Both people and systems must be flexible if growing expectations are to be met – and that's

not all. Thinking ahead and making long-term, sustainable choices is also crucially important. We are focused on precisely these issues. The system solutions SEW-EURODRIVE delivers are specifically designed to adapt to changing requirements.

Because our experience ensures your success.

With enthusiasm – over 80 years of experience in drive technology. During this time, we have gained a great deal of valuable expertise – and it doesn't stop there. On the contrary, we are well aware of how important it is to keep expanding our knowledge in these changing times. And we

are committed to passing on our experience by making sure our staff's further development is reflected in our products and services and the way these are structured and developed. Because at SEW-EURODRIVE, movement is everything.



Because our high quality is always to your benefit.

We make no compromises – and the high standards we set ourselves put you at an advantage, too. You benefit from our unconditional commitment to delivering only products and services that meet both our expectations and yours. This is a promise that you can rely on,

as our standards are checked and certified independently every single year. The results speak for themselves – SEW-EURODRIVE is certified to TÜV ISO 9001.



Why SEW EURODRIVE? Find out here why you can trust us and our drive technology.

YOUR PARTNER

OUR DRIVE IS WHAT KEEPS YOUR BUSINESS MOVING.
WE ARE A PARTNER WHO CAN TAKE YOU FORWARD.





Drive, motion, change – you can always tell when things are really getting somewhere.

And when something truly gets going, it develops its own dynamism. Harness this energy for your own success. If you are headed for the future, SEW-EURODRIVE is with you all the way – as an experienced partner on your level. With support available all over the world, and with specialists in your industry and your market focused on the challenges you face.

Planning for the future together

We can keep you moving forward – and that is a promise. Our closely linked network brings you crucial advantages. Our products are delivered at speed and can be tailored specif-

ically to your needs. Our quality is unique and fully reliable. And our expertise is at your fingertips – with international experience, detailed specialist knowledge and interlinked know-how.



A responsible pioneer

Being equipped for the future is a key challenge for you – just as it is for us. This is why we are committed to using the resources available to us responsibly, right down to the finest details. It's also why we attach so much importance to sustainability worthy of its name – from develop-

ing and producing sustainable drive solutions for our customers to cutting-edge SEW-EURODRIVE healthcare management.

It goes without saying that we fully appreciate the value of our staff, our customers, our business partners and our environment.

Thinking ahead in a way that takes account of both our business activities, and above all those of our partners, is integral to our company and paves our way to the future. Partnership-based relations lead to long-term, shared success that

benefits everyone involved. This applies to all decision-making and production processes right through to complete drive solutions equipped for today, tomorrow and beyond.



SEW-EURODRIVE is a member of the VDMA sustainability initiative BLUE COMPETENCE –

a fact that rewards our consistent focus on future-oriented, sustainable drive solutions. More information on this initiative for innovative environmental technologies can be found here.



Green – and no shades of gray

You can find out more about our commitments in our most recent sustainability report.



Knowledge that takes you further.

Sustainability also involves building on our existing knowledge. Your industry-specific requirements provide our motivation to do this – driving us forward to create well-designed and effective automation solutions that take you further within your sector.

What's more – we take both products and requirements into account in producing your ideal solution. But how does this work in practice? And how are we able to produce millions of different drive variants? The secret lies in speaking to our customers. Dialog generates new understanding that adds to our many

years of experience. The modular principle of our extensive product portfolio is based on this process and gives you the flexibility and freedom you need. We put together the individual building blocks piece by piece to help you progress and reach your goals.

We build on our knowledge on a daily basis in a range of different industries all over the world, setting new market standards and helping you expand into new fields with fast and sustainable

results. SEW-EURODRIVE industry-specific solutions ensure smooth and efficient system operation and minimize downtime. After all, functionality and investment security are paramount.

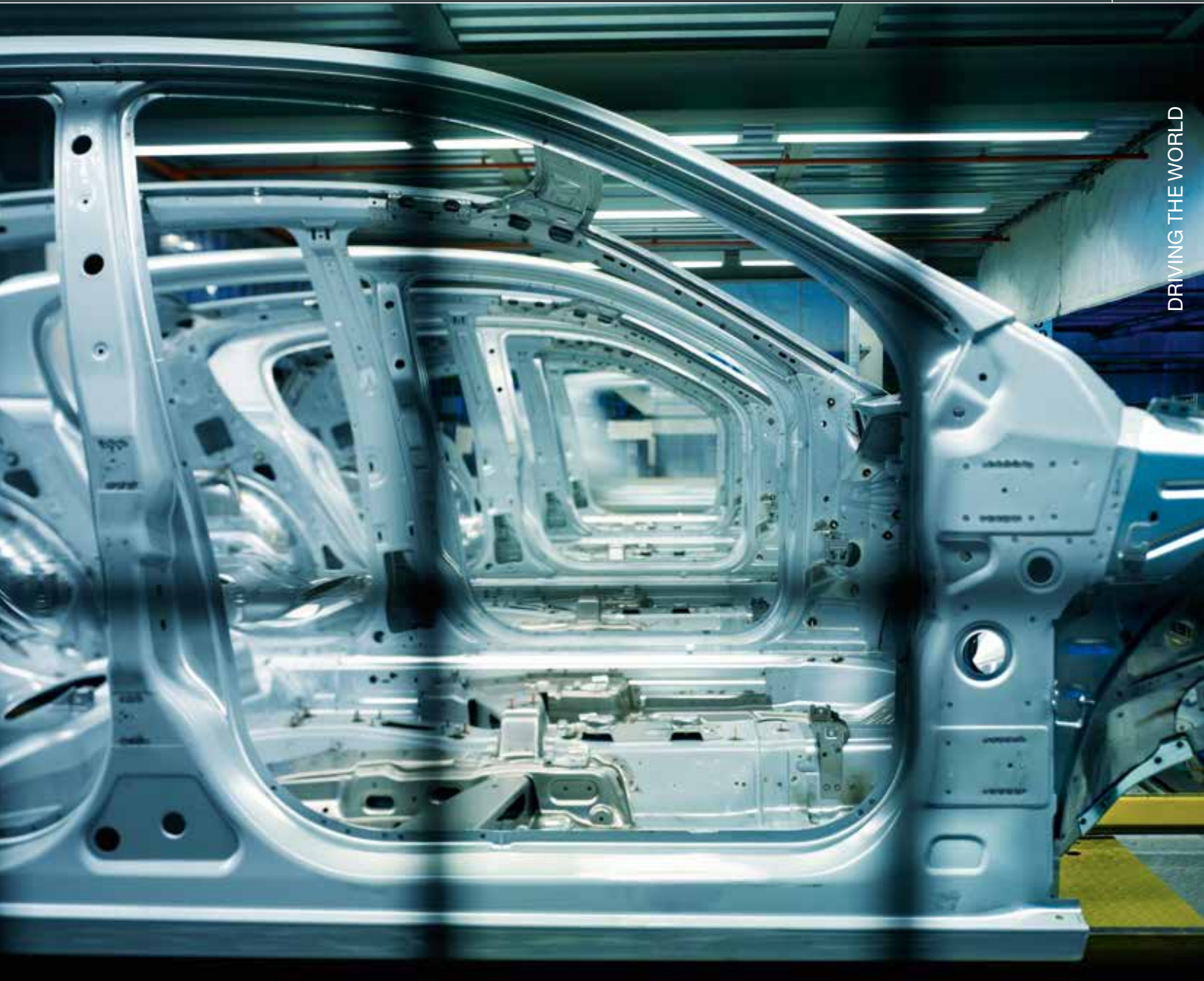

Products and systems from SEW-EURODRIVE are used all over the world, including in the automotive, beverage and consumer goods industries. See more industries here.



48
countries

- Argentina
- Austria
- Australia
- Belarus
- Belgium
- Brazil
- Canada
- Chile
- China
- Colombia
- Czech Republic
- Denmark
- Hungary
- Finland
- France
- Germany
- Great Britain
- Hong Kong
- India
- Italy
- Japan
- Kazakhstan
- Malaysia
- Mexico
- Mongolia
- Morocco
- New Zealand
- Netherlands
- Norway
- Paraguay
- Peru
- Poland
- Portugal
- Russia
- Sweden
- Switzerland
- Singapore
- Slovakia
- Spain
- South Africa
- South Korea
- Tanzania
- Thailand
- Turkey
- Ukraine
- Uruguay
- USA
- Venezuela



14
production
plants



More than 16 000
employees



79 Drive Technology Centers



Global service



At home in many
industries

YOUR SUCCESS

WHY WE'RE ON THE SAME TRACK.
OUR GOAL IS YOUR SUCCESS.

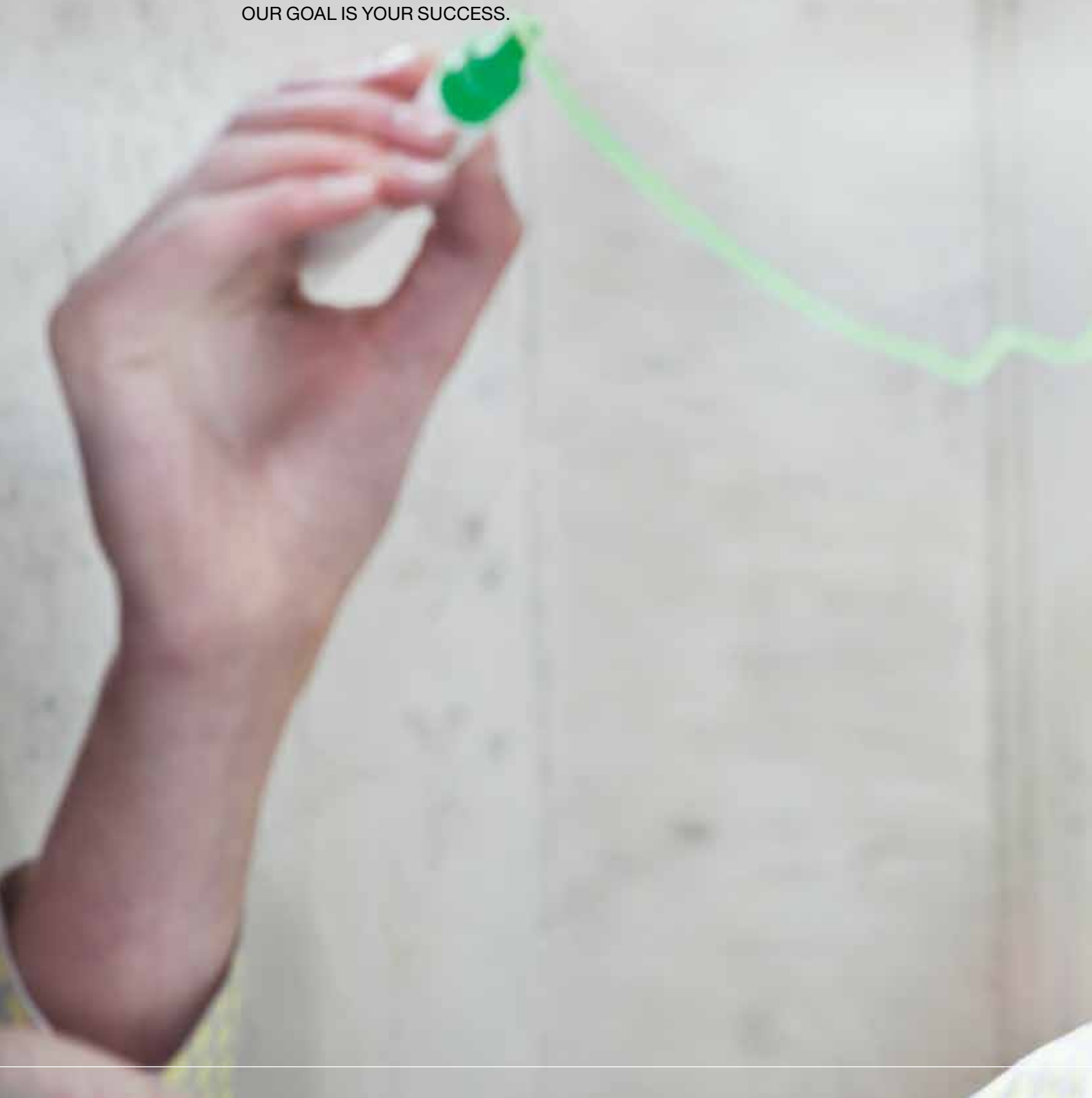



Ensure your success by optimizing your energy balance with our energy-saving solution.

Saving energy is becoming more important than ever. Industry has a crucial part to play here – and we at SEW-EURODRIVE are well aware of this key role. We have therefore developed a specially designed portfolio of options to help you save energy.

More precisely, this means that our energy-saving products fulfil all the relevant requirements and the latest criteria in energy efficiency, and are once again provided as a modular system – the specially designed energy-saving range. Since we are committed to flexible systems, our energy consultation also has a modular structure.

We work very closely with you to tailor our advice on saving energy to your precise requirements, thus contributing to cost transparency, process efficiency and measurable success. These are all highly tangible results that can be achieved through energy-saving solutions “made by SEW-EURODRIVE”.

Speaking of tangible results – major energy consumers such as production systems and machines are easy to identify. They can be monitored and, ideally, optimized. But what about “hidden” energy consumers? It can often be very difficult to fit the task of identifying energy-saving potential into day-to-day operations.

Especially if truly tangible savings are required. But we can make this possible – for instance, with our practical energy-saving tools. From our energy-saving calculator and energy report to an IE Guide, these handy tools and many more besides can help us work together to create a comprehensive energy-saving solution for you.

SEW-EURODRIVE is your reliable problem solver.
From initial and project planning through to startup and maintenance, you can read about the solutions on offer here.



We combine

- **efficient products from our modular energy-saving range**
- **comprehensive energy advice**
- **customized effiDRIVE® solutions for saving energy**
- **practical tools and resources to provide clear overviews**



Ensure your success through reliable systems featuring our safety solutions.

Your success depends on faultless, reliable and cost-effective system operation. The support we provide here is twofold – embracing concepts for ensuring the functional safety of your systems and machines, and explosion-proof products that comply with the most important guidelines and standards worldwide.

Monitoring keeps downtime to a minimum.

The safetyDRIVE concept covers products and solutions for functional safety (FS) that can easily be integrated into many machines and systems.

This includes your industry – you too can use safetyDRIVE to boost the safety of your staff and work processes and keep downtime to a minimum.

Find out how safetyDRIVE products and services can increase the safety of your staff and work processes here.





Our explosion-proof drive technology is ideal for meeting the complex international requirements that apply in areas at risk of explosion. We offer reliable compliance with all these requirements.

Our technology is already used in all kinds of applications like this – in chemical and power plants, coating facilities, wood processing centers, and many other fields of logistics.



Explosion protection “made by SEW EURODRIVE” – read more about guidelines and standards here and find out where they apply.

OUR SERVICES

BECAUSE YOUR REQUIREMENTS START THE BALL ROLLING.
OUR TAILOR-MADE SERVICES CAN BE USED IN ANY COMBINATION.



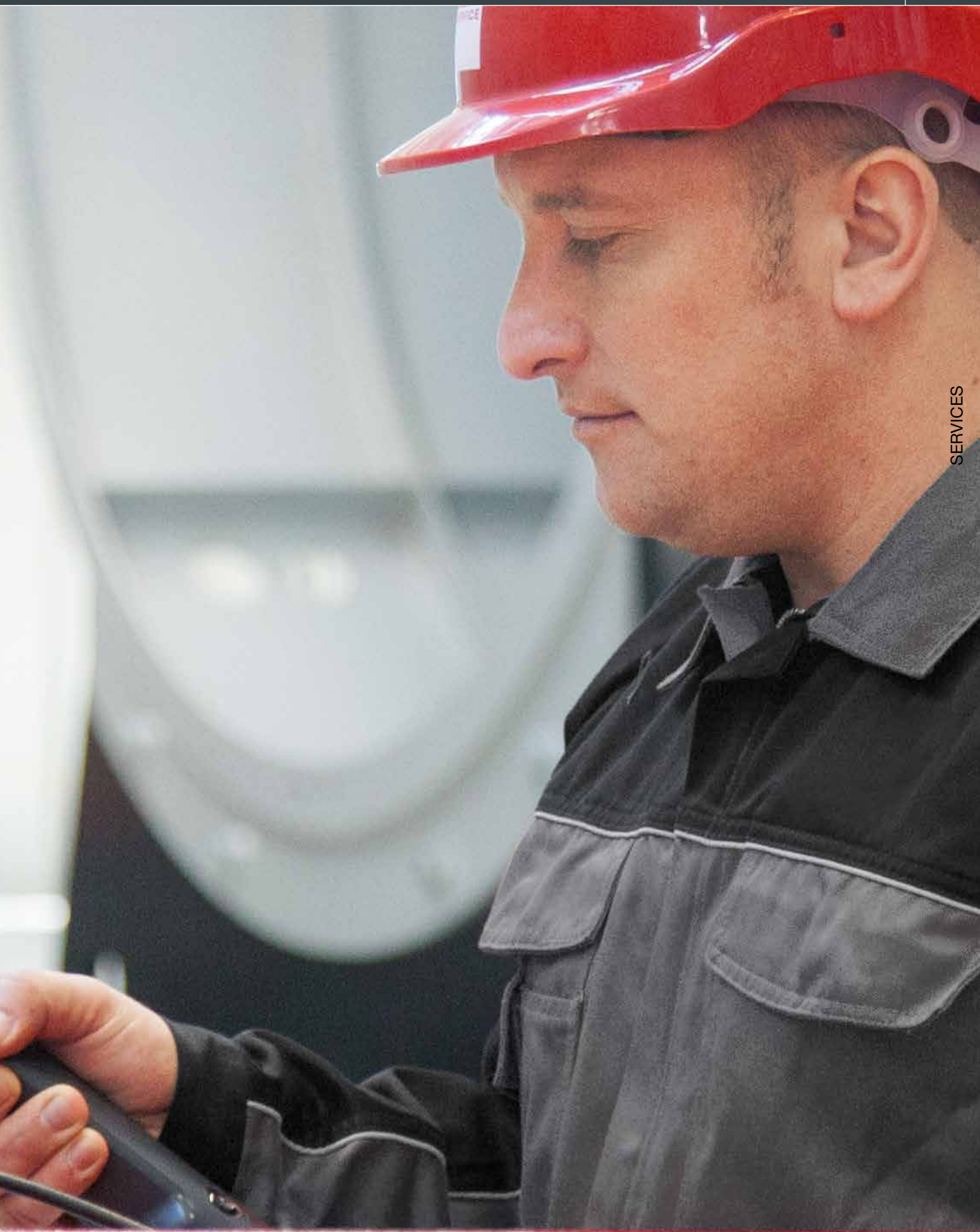

SERVICES



Engineering & selection

- Engineering consulting
- Engineering tools
- Training from SEW-EURODRIVE
- Safety services
- Energy consulting



Startup & maintenance

- 24h Service Hotline
- Installation Consulting Service
- Startup Service
- Inspection and Maintenance Service
- etc.





Inquiry & order

- Shopping cart
- Transaction overview
- Electronic data interchange (EDI)
- Electronic invoicing



Delivery & material flow

- Electronic delivery notification
- Intelligent material flow with DriveTag

Services throughout the value creation chain

Being a specialist in drive technology means we never stop moving. In addition to constantly optimizing our own processes, we therefore also offer a comprehensive range of services along your entire value chain. This defines the approach to adopt, while our services focus on the relevant process steps.



Step 1: Engineering & selection

Even at this first step, our services extend far beyond simple product selection. Comprehensive consulting, customized training and tailor-made engineering tools provide you with effective support exactly where you need it.

Your added value: Optimized day-to-day operations – before you even place your order, with everything monitored by our technical experts who have detailed knowledge of your industry and applications. It goes without saying that we offer personal support, providing direct advice on engineering issues, how to effectively cut energy costs or how to use our engineering tools.

Benefit from our comprehensive practical training to ensure you are always using state-of-the-art technology, and from our safety services and associated consulting activities to ensure the necessary level of safety. The portfolio includes for example our variant management:

Variant management

For a perfect overview at all times. In variant management from DriveBenefits, we upload the SEW-EURODRIVE products you have already inquired about or ordered to a database. This allows us to support you in standardizing and minimizing product variants and simplifying your master data management. A wide range of fil-

ter and comparison options enable you to make your selection from products you have already used. This means you can base searches on a number of technical product features such as motor power, output speed and output torque. As a result, you reach a decision faster and save a great deal of time searching in other systems.

Your advantages

- **Detailed overview** thanks to a list of the drive technology used, even across several sites.
- **Fast product selection** from items you have already inquired about or ordered.
- **Targeted selection process** thanks to a wide range of filter and comparison options based on a number of technical features.
- **Worthwhile cost saving** by avoiding new product variants.



Save time and money – with DriveBenefits modules! How? Find out more about the process solutions offered by DriveBenefits.

- **Engineering consultation** puts you in the best possible position. We advise you on the appropriate components to select in a service that extends right up to the preliminary design of your drive technology solutions. Your advantages: Compliance with standards, fewer errors and long-term benefits.
- **Engineering tools** from DriveBenefits create ideal conditions. Use the SEW Workbench, the DriveConfigurator, variant management or replacement product selection to choose or plan your next drive technology.
- **Advice on saving energy** highlights valuable potential. From basic consulting and data acquisition to energy efficiency analyses and performance reviews, we help you to identify and harness potential for saving energy. Your advantage: This holistic approach creates scope for other investments and ensures you can rely on certified safety.
- **Training** keeps your knowledge at the highest possible level. Qualifications are a key way of standing out from the competition. Our wide-ranging training portfolio ensures you make practical progress. See for yourself what SEW-EURODRIVE's DriveAcademy® has to offer in the way of training.
- **Our safety consulting** gives you more than just peace of mind. The safety services from our safetyDRIVE program provide safety components and characteristics, while our modular safety service packages certified by TÜV Rheinland are based on the 16 phases of the IEC 61508 standard's safety life cycle, which we have grouped into practical units. You benefit from cost-effective planning, safe practices, efficient operations and a reduced workload.
- **For more information, go to www.sew-eurodrive.de/services/**





Step 2: Inquiry & order

The second step is to improve the speed and quality of your procurement process. Decide for yourself which inquiry and order service suits you best and where you can simplify or even automate your processes.

Your added value: You benefit from the know-how and support of an expert partner in all aspects of electronic procurement. Offering a range of personal, tailor-made services, we advise and assist you in making your procurement process more efficient. Naturally, this is always

adjusted specifically to your strategic focus and business processes. The portfolio includes for example our electronic data interchange (EDI) service for straightforward electronic order management:

Electronic data interchange – EDI

Electronic data interchange (EDI) from Drive-Benefits supports full electronic order management – all the way from placing your order to order confirmation, delivery notifications and invoices. Take advantage of the huge potential

for automation offered by EDI. Automated interchange can take place using platforms such as MyOpenFactory, Basware and Seeburger AG or via direct link to SEW-EURODRIVE with standard formats such as EDIFACT or XML.

Your advantages

- **Huge cost savings** thanks to fully electronic processing.
- **Faster order processes** with data transferred in a matter of seconds and improved response times.
- **Enhanced process reliability** due to the absence of manual processing steps.
- **Reliable order processing** thanks to fully automated data transfer preventing transmission errors.



Save time and money – with DriveBenefits modules! How? Find out more about the process solutions offered by DriveBenefits.

- **NEW: DriveBenefits shopping cart** with lots of product information. You can inquire about and order all standard SEW-EURODRIVE products and spare parts at any time. What's more, you have direct access to all relevant information.
- **NEW: DriveBenefits transaction overview** for greater transparency. Track the status of all your business transactions with SEW-EURODRIVE and create complete documentation packages for several transactions or entire projects in just a few simple steps.
- **Electronic invoicing from DriveBenefits** ensures quick availability of your invoices, saves time and helps the environment. Optimize your processing of incoming invoices and your administrative processes – regardless of whether invoices are sent by e-mail, with an additional XML data file or using EDI.
- **For more information, go to www.sew-eurodrive.de/services/**





Step 3: Delivery & material flow

Optimize your logistics processes with the range of services in this process step. You can reduce the time you spend dealing with incoming goods, make your internal material flow more dynamic and control all deliveries and their subsequent internal use more efficiently. Decide what suits you best.

Your added value – whether more efficient resource planning thanks to prompt notification that goods are on their way or more targeted control of all deliveries, our tailor-made services ensure you are always extremely well organized, save valuable time and are ready to put our

products to good use. Benefit from this added value and see for yourself just how advantageous it is. The portfolio includes for example our DriveTag functional barcode labels on packages or drives, which help optimize your flow of goods:

DriveTag

DriveTag from DriveBenefits – functional barcode labels that are attached to drives or packages for straightforward electronic identification. This

means it is easy, for example, to automate your incoming goods processes and make your internal material flow more dynamic.

Your advantages

- **Straightforward identification** of products and deliveries using a barcode scanner.
- **Simple handling** thanks to functional labels with printed barcode and plain text.
- **Low error rate** as no manual data entry is required.
- **Less time required** thanks to automated incoming goods processes and a more efficient material flow.



Save time and money – with DriveBenefits modules! How? Find out more about the process solutions offered by DriveBenefits.

- **Electronic delivery notifications from DriveBenefits** announce goods are on their way. We let you know as soon as your delivery leaves our premises. This keeps you in the picture and enables you to take the necessary steps. As a result, you benefit from optimized resource planning, precise control of production planning and speedy goods receipt processes.
- **For more information, go to** www.sew-eurodrive.de/services/





Step 4: Startup & maintenance

The fourth step covers the modular CDS® – Complete Drive Service system. You can make your very own CDS® selection to suit your particular needs and use this in isolation, as a complete package or in the form of your own perfect personal service package – with the specific modules that give you the best possible support. Decide for yourself what you need in order to move forward.

Your added value: Our CDS® – Complete Drive Service system always gives you exactly what you need, anytime, anywhere and always from SEW-EURODRIVE. After all, we know that our

customers' requirements can differ greatly. One very topical example is the ability to retrofit specific drive components.



CDS® modules



24h Service Hotline for round-the-clock service. A toll-free number provides access to an SEW-EURODRIVE service specialist 365 days a year to give you the answers you need.



Installation Consulting Service to ensure a smooth installation phase. Our experts give you the benefit of their experience and knowledge and support you from the outset – from the selection process and project planning all the way through to startup.



Startup Service for fast, cost-effective startup of new or modernized systems. This boosts your productivity by making adjustments to fit your specific drive technology.



Application Programming Service for complex applications. Customizable software ensures the required level of flexibility. Optimize process flows and take advantage of the free tools provided.



Inspection and Maintenance Service to prevent system failures. Minimize your running costs, safeguard the system functions and take advantage of our maintenance service for other manufacturers' products.



Repair Service with short repair times anywhere in the world, including other makes of product. We will keep your system availability and productivity at a consistently high level – thanks to experts with state-of-the-art technical know-how.



Spare Parts Service with excellent availability. 95 percent of all orders benefit from same-day shipping. Whether in person or online, you will always benefit from the fastest service for the spare parts, repair kits and conversion kits you require.



Express Assembly Service for rapid supply. Excellent availability thanks to decentralized parts storage and rapid replacement, even for other manufacturers' products.



Industrial Gear Unit Service incorporating comprehensive know-how. Benefit from reduced costs thanks to an all-in service from a single source. This global service also covers other makes of product and ensures excellent operational reliability.



Pick-Up and Delivery Service for fast results. You benefit from fast pick-up and delivery, short downtimes and enhanced operational reliability. We also help you disassemble and reassemble components and units.



Retrofit Service to optimize the availability and process reliability of your existing system. We make sure you benefit from state-of-the-art systems, lower energy costs and higher productivity.



Condition Monitoring Service for complete concepts. This service includes comprehensive initial consulting, targeted evaluations and optimum analyses. For lower storage costs combined with improved productivity, availability and reliability.



CDM® Maintenance Management to safeguard the availability of your machinery and systems. You benefit from minimal demands on your time, optimized maintenance, reduced storage costs and absolute transparency.



Training Service to add the finishing touch to all-in drive solutions. Make sure your know-how also remains at the highest level. We offer a varied training program that ensures you have all the information you need to operate cutting-edge drive technology.



You can find out more about the CDS® – Complete Drive Service system here.

CDS® module: Condition Monitoring Service

Time is money and maintenance is certainly no exception, so take advantage of the ideal product/service combination with drive technology diagnostic units from the modular CDS® system. If the idea of straightforward monitoring and troubleshooting on the fly appeals to you, feel free to contact us for further information from our service specialists.



For more information, go to
www.sew-eurodrive.de/services/

Diagnostic unit DUO

Diagnostic Unit Oil Aging

Gear unit oil diagnostics through thermal analysis

Features

- The perfect sensor to determine the remaining life of the gear unit oil and reliably indicate the right time for an oil change
- A thermal sensor installed in the gear unit measures the oil temperature and sends this information to an evaluation unit, which then calculates the time remaining until the next oil change for the specified oil type
- The diagnostic unit takes into account the oxidation characteristics of the different oils under thermal loading

Benefits

- Reduces oil costs
- Full utilization of the oil service life
- Startup can be performed directly on the diagnostic unit (without PC)
- Simple identification and reading of the time remaining until the next oil change
- 5 different oil types can be configured
- A warning message is issued if predefined limit values such as max. oil temperature are exceeded
- Permanent monitoring of oil aging
- Maintenance intervals can be planned individually



NEW: Diagnostic unit option /DUE *

Diagnostic Unit Eddy Current

Brake diagnostics through continuous functional and wear monitoring

Features

- Ideal sensor to monitor the wear and proper functioning of the brake (BE../BF../BT..)
- Measuring system for contactless monitoring of the working air gap
- A single sensor reliably monitors both the correct functioning of the brake and the wear of the lining

Benefits

- Brake lining wear can be detected in good time
- Reliable brake function monitoring
- Contactless and thus wear-free measuring system
- Direct evaluation via an SEW-EURODRIVE frequency inverter with corresponding fault protocol
- Can be used in damp conditions up to IP66
- Maintenance intervals can be planned individually according to wear



* Available from the 2nd quarter of 2015

Diagnostic unit option /DUB

Diagnostic Unit Brake

Brake monitoring

Features

- Ideal sensor to monitor the wear and proper functioning of the brake
- The voltage-dependent signal can be evaluated by an SEW-EURODRIVE frequency inverter or a higher-level controller.
- Two sensors can reliably monitor both the correct functioning of the brake and the wear of the lining

Benefits

- Brake lining wear can be detected in good time
- Reliable brake function monitoring
- The condition signal of the microswitch can be implemented as a normally closed (monitoring wear) or normally open (monitoring proper functioning) contact
- Direct evaluation via an SEW-EURODRIVE frequency inverter with corresponding fault protocol
- Can be used in damp conditions up to IP65
- Self-cleaning contacts inside the sensor
- Maintenance intervals can be planned individually according to wear



Online Support

Welcome to a whole new dimension – online support is your new way of accessing all SEW-EURODRIVE services available online. The logical structure based on process steps gives you direct, easy access to the functions that are relevant to you.

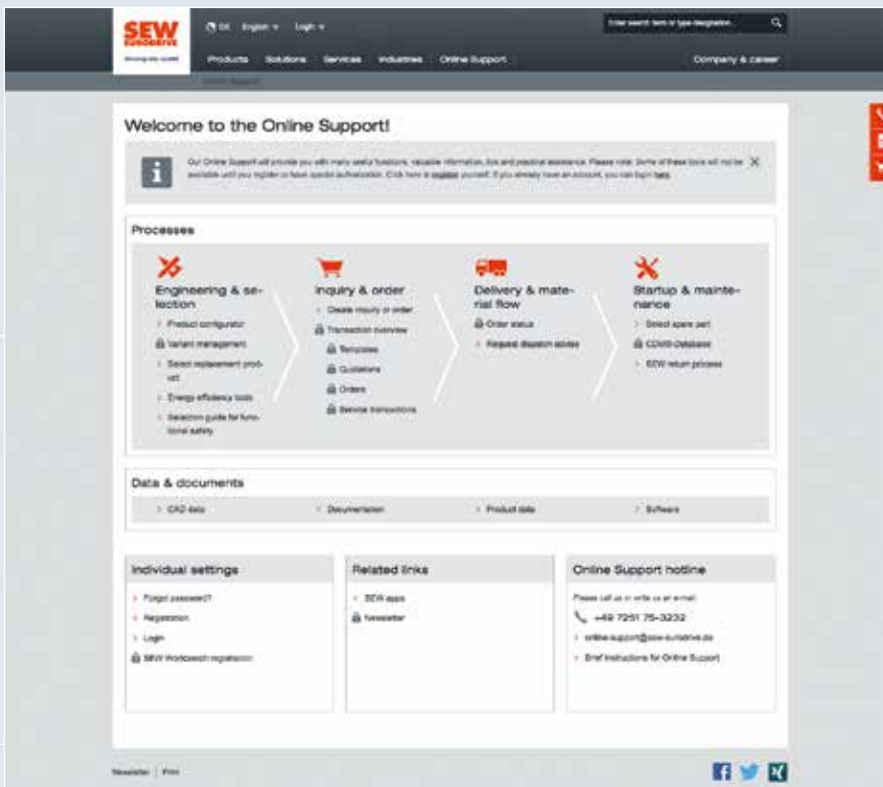

Optimum support – personalized to your specific needs. Numerous new functions are available without logging in. Logging in with a password, you can also benefit from a whole range of personalization options and use further functions that we will activate for you as required.

“Data & documents” is the quickest way to find what you are looking for. CAD data, product data, software and technical documentation relating to your product are available here.

All kinds of possibilities in one place – discover SEW-EURODRIVE's new online support tool.



Mobile applications

If you want mobile support, we can oblige with our useful drive technology apps that supply practical information and services straight to your cell phone. Do you need troubleshooting

assistance or want to download technical data for your drive components? Would you like to receive details of the modular CDS® system? Our apps make it easy.



Fast access on the move – see for yourself and find out about our cell phone apps here.

OUR SOLUTIONS

THINK BIG TO REAP BIG REWARDS.
OUR SOLUTIONS FOR THE FUTURE ARE AVAILABLE NOW.





Solutions from SEW-EURODRIVE

Do you have completely new or very specific challenges for us? Whatever industry you operate in, we are there for you worldwide, ensuring systematic further development of our components, our modular system and our solutions.

SEW-EURODRIVE is already creating and implementing solutions for the tasks of the future:

- predefined solutions
- tailored system solutions
- powerful industrial gear units

This will enable us to meet the challenges that lie ahead and always offer you exactly what you need – today, tomorrow and further into the future.



Scalable and predefined – innovative application solutions from a single source.

Our packages support mechanical and plant engineers from the planning phase onward. SEW-EURODRIVE's complete technical solutions help to optimize your value creation chain. The tried-and-tested drive and automation technology comes from SEW-EURODRIVE.



Conveyor Line Package

decentralized technology, energy-efficient drive and flexible design for state-of-the-art conveyor lines



Packaging Unit Transport Package

for transporting empty bottles, packaging units and pallets, with MOVIGEAR® drive



Corner Transfer Unit Package

ideal drive and control concept integrated into conveyor lines



Storage/Retrieval System Package

energy-efficient operation thanks to integrated regenerative power supply module, for small-parts or pallet warehouses



Item Transport Package

optimized for use in wet areas transporting various packaging units in bottling plants



FFS Machine Package

with dynamic servo drives and standardized interfaces for connecting all functions

What we offer on top of that will deliver real benefits – software that perfectly matches the application and functions correctly, optimized order and delivery processes, and application-specific documentation. Customizations are

naturally also possible. All this is rounded off by our range of services geared to the specific package, such as startup or customizing the software module. As a result, our solution creates a complete package for you.

Your added value: You benefit from scalable solutions, reliable system planning, faster implementation and optimized process costs.



Packers/Unpackers Package

smooth and dynamic with integrated software modules



Bridge Crane Package

prevents goods being transported from swinging, positions them accurately and is suitable for bridge, overhead and bracket cranes



Vertical Conveyor Package

accurate axis placement, safe lifting and flexible positioning



Pallet Transfer Shuttle Package

decentralized control via MOVIPRO® for a more compact design and software module for project-specific adjustments



Scissor Lift Table Package

for lifting larger loads using control cabinet or decentralized technology



You find more information about our packages here.

Practical example

of the focus on your requirements.

The idea of scalable packages sounds great, but what are they really like? In fact, they are very straightforward, completely unique tailor-made solutions. Take the example of the storage/retrieval package system with functional safety technology. This package solution was designed for storage/retrieval units and naturally complies with the current standard requirements applying to such systems.

Your benefit: Everyone involved, i.e. system manufacturers and operators, benefits from the safety functions integrated in the drive system and also the safety-related services offered by SEW-EURODRIVE.

Our packages – innovative and comprehensive

- Tried-and-tested drive and automation technology
- Function-oriented software modules
- Optimized order and delivery processes
- Application-specific documentation
- Customizations are possible

Your added value when using our packages:

- Scalable solutions
- Reliable system planning
- Faster implementation
- Optimized process costs

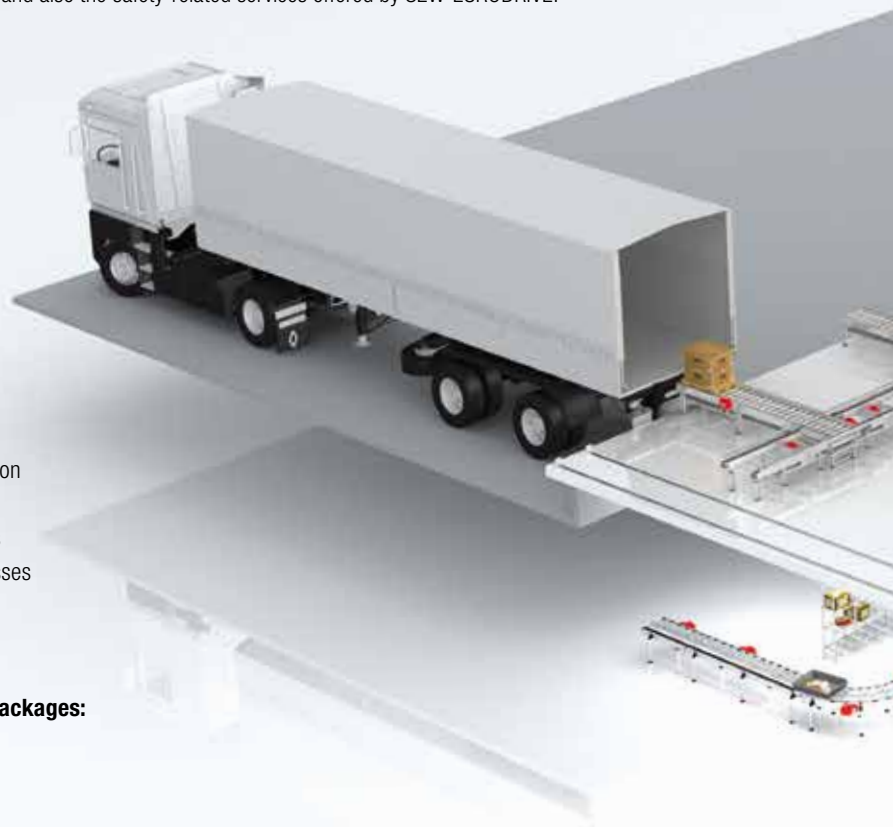

Software

- Energy savings of up to 25 percent through optimized movements
- Axes in sync during shutdown
- Safe drive status after shutdown (STO / SS1 / SS2)





Safety technology

- Support in selecting drive technology components based on requirements of new standards
- Safety-related services extending throughout the project – from concept all the way through to startup



Tailor-made success – system solutions for every movement.

MAXOLUTION® from SEW-EURODRIVE delivers tailor-made system solutions with a built-in guarantee of success. Our MAXOLUTION® system solutions supply all the necessary modules to create customized machinery and systems that ideally match your requirements.

Overview of MAXOLUTION® system solutions

Automated guided vehicle (AGV) systems

- Variant 1:
Track-guided heavy-duty AGV systems with inductive energy transfer
- Variant 2:
Track-guided hybrid heavy-duty AGV systems with Drive Power Solution and inductive charging

Skillet

- For flexible and ergonomic adjustment of the working height of assembly platforms
- Wear-free, contactless energy transfer

Pallet transfer shuttle

- With wear-free, contactless energy transfer and decentralized drive control

EMS advanced – electrified monorail system

- Drive control combined with positioning and wireless communication
- Impressive system solution with straightforward, flexible configuration

EMS safety – electrified monorail system

- Includes drive control system with positioning as well as wireless communication and safety technology
- Flexible, straightforward configuration

EMS basic electrified monorail system

- Compact system solution for simple transportation tasks with half-wave control and configurable functions

You can find more information about
MAXOLUTION® system solutions here.



They range from electromechanical drives, controllers, communication, visualization and contactless energy transfer to the varied service portfolio that provides you with fast and reliable support from experienced professionals.

Our system specialists form a core team that delivers industry-specific expertise and works closely with the sales and service staff you are already familiar with.

Your added value: Everything from a single source. We ensure you receive the best possible advice and support, with fewer interfaces and just one contact for the entire system solution. Fast, straightforward and comprehensive with a constant focus on your needs.

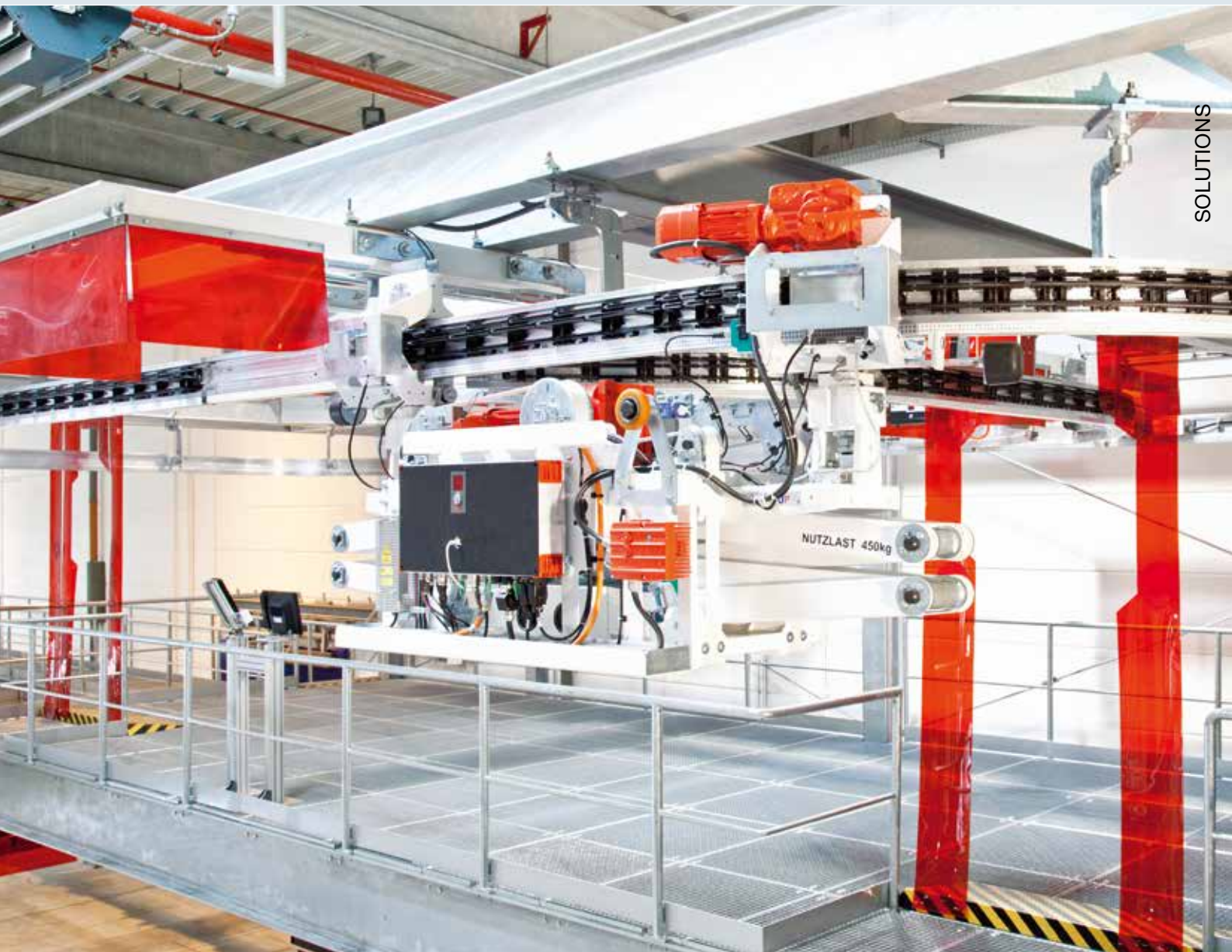

Possibilities at a glance - sample applications.

Our MAXOLUTION® system solutions are just as unique as your ideas and requirements. A few insights will give you an indication of how and where the project-specific solutions are used, but a personal discussion is the best way to

provide you with more detailed information and ideas with regard to the support MAXOLUTION® can offer. Whatever form your solution takes, you will benefit from reduced complexity thanks to coordinated system components and uniformity.





Individuality and many years of expertise

In addition to tailor-made system solutions, MAXOLUTION® also boasts a comprehensive, adaptable modular service concept. Thanks to our years of experience in providing system solutions for projects, we have built up a modular service concept for optimizing your project implementation.

The portfolio covers every phase of the product life cycle – from consulting, planning and engineering to implementation, startup and production monitoring. We offer you a comprehensive solution geared to your specific needs and coordinated with our system solutions.

Our services

- Customized consulting / engineering
- System and machine simulation
- Worldwide delivery logistics
- Project-specific hardware and software adjustments
- Safety concept, including validation
- Radio and energy planning
- System testing and startup
- Production monitoring

For more information go to
www.sew-eurodrive.de/home.html

Powerful and intelligent – industrial gear unit solutions from a single source.

Even an inquiry relating to industrial gear units implies more than an interest in individual components. Heavy-industry plant manufacturers involved in mining, the building of cement works and the construction sector in general have specific solutions in mind and are looking for tailor-made packages. In this case, too, SEW-EURODRIVE offers you more than just products. Benefit from our application know-how and associated process and logistics expertise – from engineering all the way through to service.

One significant benefit is that virtually no other supplier on the market offers such a comprehensive portfolio of drive technology from a single source. In other words, the solutions we provide for you are based not only on wide-ranging expertise in mechanical, electrical and electronic drive technology

“made by SEW-EURODRIVE” but also, above all, on extras such as our specialist knowledge of control technology, engineering tools, systems software, machine safety and energy efficiency. When it comes to industrial gear unit solutions, it’s the entire package that matters. And that’s exactly what we give you.





SEW-EURODRIVE is your reliable problem solver. From initial and project planning through to startup and maintenance, you can read about the solutions on offer here.

SEW-EURODRIVE as a system supplier

Expert advice is a given as far as we are concerned and it forms part of our comprehensive service to you – worldwide. Whether Assembled to Order (ATO) or Engineered to Order (ETO), we are happy to tackle your specific challenges and grow along with your projects. In heavy industry in particular, orders that do not involve any construction work tend to be in the minority. If you

choose SEW-EURODRIVE as your partner, our sales personnel will deal with potential problems locally, for example by analyzing system complexity. Using our international network of local application support personnel and harnessing their experience and industry know-how means we can provide you with assistance wherever you need it, including cross-border support.

Your added value: You can rely on our application specialists to listen to, understand and clarify your specific requirements. Our consultants will work with you on the preliminary design from an early stage, using customized co-engineering.

We will also ensure global coordination of the intensive consulting services associated with international projects and involve your local end customers.



For more information go to
www.sew-eurodrive.de/home.html



OUR PRODUCTS

TAKING FLEXIBILITY TO A WHOLE NEW LEVEL.
OUR INNOVATIVE PRODUCTS FROM THE UNIQUE MODULAR SYSTEM.





Gear units	62
Gearmotors	82
Motors	102
Industrial gear units	144
Decentralized drives / mechatronics	160
Inverter technology	178
Servo drive technology	220
Industrial communication	268
Control technology	280
Operation and startup	292
Safety technology	304
Contactless energy transfer system	312
Didactic modules	318

01 GEAR UNITS

1.1 Standard gear units

Helical gear units, R series	64
Parallel-shaft helical gear units, F series	65
Helical-bevel gear units, K series	66
Helical-worm gear units, S series	68
SPIROPLAN® right-angle gear units, W series	69

1.2 Servo gear units

Planetary servo gear units, PS.F / PS.C series	70
Helical-bevel servo gear units, BS.F series	72

1.3 Stainless steel gear units

Helical gear units, RES series	74
Helical-bevel gear units, KES series	74

1.4 Explosion-proof gear units

Standard gear units, R, F, K, S, W series	76
Servo gear units PS.F, BS.F., CMP. series	77

1.5 Accessories and options:

Corrosion and surface protection	78
TorqLOC® hollow shaft mounting system	81



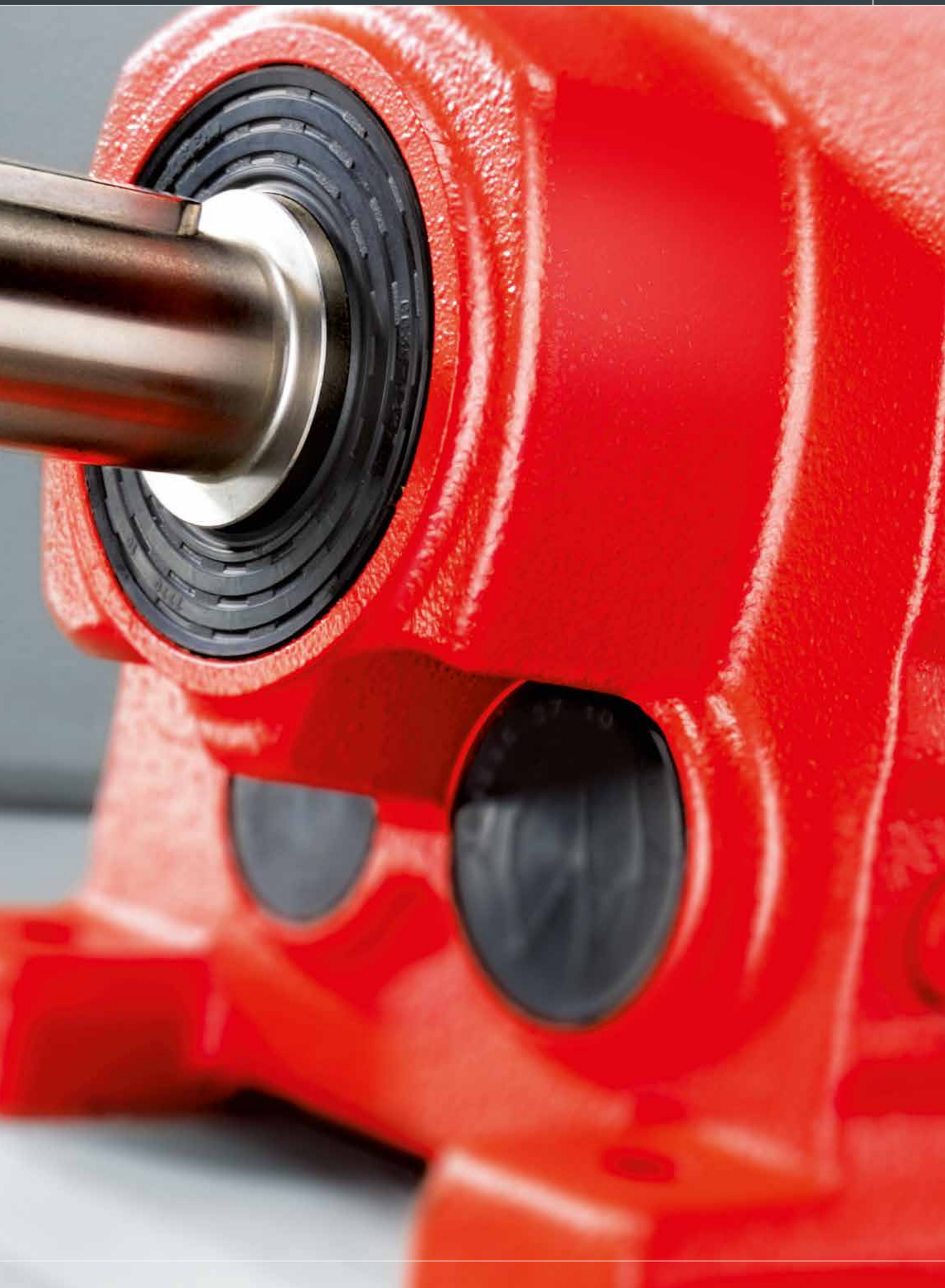

1.1 Standard gear units

Helical gear units



RX series (single-stage)

Sizes 57 / 67 / 77 / 87 / 97 / 107

Features	<ul style="list-style-type: none"> – Highly efficient helical gear units – High output speeds – Foot- or flange-mounted design 	
Gear unit ratio	i	1.30 – 8.65
Max. output torque	Nm	69 – 830
Motor power range (mounting via AM motor adapter)	kW	0.12 – 45



R series (two and three stages)

Sizes 07 / 17 / 27 / 37 / 47 / 57 /

67 / 77 / 87 / 97 / 107 / 137 / 147 / 167

Features	<ul style="list-style-type: none"> – Optimum ratio between performance and space requirements – Finely stepped sizes and gear ratios – Foot- or flange-mounted design – Also available with reduced backlash 	
Gear unit ratio	i	3.21 – 289.74
Gear unit ratio – double gear units	i	90 – 27 001
Max. output torque	Nm	50 – 18 000 *
Motor power range (mounting via AM motor adapter)	kW	0.12 – 90

* Also with reduced backlash



RM series (two and three stages)

Sizes 57 / 67 / 77 / 87 / 97 / 107 / 137 / 147 / 167

Features	<ul style="list-style-type: none"> – Helical gear units with extended output bearing hub – Specifically designed for agitating applications – Allow for high overhung and axial loads as well as bending moments 	
Gear unit ratio	i	4.29 – 289.74
Gear unit ratio – double gear units	I	134 – 27 001
Max. output torque	Nm	450 – 18 000
Motor power range (mounting via AM motor adapter)	kW	0.12 – 90

Parallel-shaft helical gear units



F series (two and three stages)

Sizes 27 / 37 / 47 / 57 / 67 / 77 / 87 / 97 / 107 / 127 / 157

Features	<ul style="list-style-type: none"> – Slim design for limited installation space – Also available with reduced backlash – Particularly suited for materials handling and process engineering applications – Possible variants: Foot- or flange-mounted design, B5 or B14 flange, Solid or hollow shaft, hollow shaft with keyed connection, shrink disk, splining or TorqLOC® 	
Gear unit ratio	i	3.77 – 281.71
Gear unit ratio – double gear units	i	87 – 31 434
Max. output torque	Nm	130 – 18 000 *
Motor power range (mounting via AM motor adapter)	kW	0.12 – 90

* Also with reduced backlash

1.1 Standard gear units

Helical-bevel gear units



K series (three stages)

Sizes 37 / 47 / 57 / 67 / 77 / 87 / 97 / 107 / 127 / 157 / 167 / 187

Features

- Their high level of efficiency makes them energy-saving angular drives
- High-endurance gearing makes for high-torque, wear-free drives
- Long maintenance-free service life
- Also available with reduced backlash
- Possible variants:
 - Foot- or flange-mounted design
 - B5 or B14 flange
 - Solid or hollow shaft
 - Hollow shaft with keyed connection, shrink disk, splining or TorqLOC®

Gear unit ratio	i	3.98 – 197.37
Gear unit ratio – double gear units	i	94 – 32 625
Max. output torque	Nm	200 – 50 000 *
Motor power range (mounting via AM motor adapter)	kW	0.12 – 90

* Also with reduced backlash



NEW: 2-stage helical-bevel gear units

Sizes K..19, K..29, K..39 and K..49

Features

- Can be used in all industries and applications, e.g. in lifts or conveyor applications
- Low loss, two-stage design (helical/hypoid gearing)
- Gearing with infinite fatigue strength, which means the drive is almost wear-free
- Can be combined with the complete range of motors from SEW-EURODRIVE
- Energy efficiency:
 - Gear unit efficiency of more than 90% → low energy consumption
 - Gear unit efficiency allows for smaller motors → compact design
 - Motor energy efficiency class from IE1 to IE4 can be realized
- Wide range of designs ensures an optimum connection to the customer machine even in critical mounting situations

		Size K..19	Size K..29	Size K..39	Size K..49
Max. output torque	Nm	80	130	300	500
Solid shaft	mm	20	25	30	35
Hollow shaft with key KA..	mm	20	25/30 (30 according to DIN 6885-3)	30/35	35/40
Flange diameter K.F..	mm	120 / 160	160 / 200	160	200
Gear unit ratio	i	4.50 – 58.68	3.19 – 71.93	2.8 – 58	3.5 – 75
Motor power range (mounting via AM motor adapter)	kW	0.12 – 1.1	0.12 – 2.2	0.12 – 4.0	0.12 – 7.5

1.1 Standard gear units

Helical-worm gear units



S series (two stages)

Sizes 37 / 47 / 57 / 67 / 77 / 87 / 97

Features

- Significantly more efficient than plain worm gear units due to helical-worm combinations
- Very low-noise operation
- Possible variants:
 - Foot- or flange-mounted design
 - B5 or B14 flange
 - Solid or hollow shaft
 - Hollow shaft with keyed connection, shrink disk, splining or TorqLOC®

Gear unit ratio	i	3.97 – 288.00
Gear unit ratio – double gear units	i	110 – 33 818
Max. output torque	Nm	92 – 4 000
Motor power range (mounting via AM motor adapter)	kW	0.12 – 30

SPIROPLAN® right-angle gear units



W series (one and two stages)

Sizes 10 / 20 / 30 / 37 / 47

Features

- Robust right-angle gear units with SPIROPLAN® gearing, wear-free and lightweight
- Material combination of steel on steel gearing
- Particular tooth meshing ratio
- Lightweight aluminum housing
- Can be used in any mounting position as the oil fill is independent of the mounting position; no need to change the oil fill quantity
- Possible variants:
 - Foot or flange-mounted design
 - B5 or B14 flange
 - Solid or hollow shaft

Gear unit ratio	i	3.20 – 75.00
Max. output torque	Nm	25 – 180
Motor power range (mounting via AM motor adapter)	kW	0.12 – 3.0

- ➔ **Accessories and options for standard gear units:**
- Surface and corrosion protection: pages 78 – 80
 - TorqLOC® hollow-shaft mounting system: page 81
 - Diagnostic units: page 39

1.2 Servo gear units

Planetary servo gear units



PS.F series

Features

- Low backlash planetary servo gear units
- Designed for nominal torques from 25 Nm to 3 000 Nm
- Available in three output variants:
 - PSF = B5 output flange, smooth solid shaft (without key)
 - PSKF = B5 output flange, solid shaft with key
 - PSBF = B5 output, flange block shaft according to EN ISO 9409
- Life-long lubrication
- High permitted overhung loads

Type	Size single-stage/ two-stage	Torque class Nm	Overhung load range N	Gear unit ratios i	Rotational clearance (single-stage/double-stage)		
					Standard	Optional	
						Reduced (../R)	Minimized (../M)
PS(K)F	121 / 122	25	1 900 – 2 000	single-stage ¹⁾	8' / 10'	4' / 6'	2' / 3'
	221 / 222	55	1 720 – 2 680	3 ²⁾ , 4, 5, 7, 10	6' / 8'	3' / 4'	1' / 2'
	321 / 322	110	4 380 – 5 480				
	521 / 522	300	6 150 – 9 610				
	621 / 622	600	13 400 – 14 200	two-stage ¹⁾	4' / 6'	2' / 3'	1' / 1'
	721 / 722	1 000	25 700 – 35 900	16, 20, 25, 28,			
	821 / 822	1 750	51 400 – 62 800	35, 40, 49, 70,			
	921 / 922	3 000	55 000 – 83 300	100			
PSBF	221 / 222	55	1 530 – 5 000	single-stage	6' / 8'	3' / 4'	1' / 2'
	321 / 322	110	8 580 – 25 000	5, 7, 10			
	521 / 522	300	13 900 – 40 000				
	621 / 622	600	20 800 – 60 000	two-stage	4' / 6'	2' / 3'	1' / 1'
	721 / 722	1 000	37 900 – 120 000	15 ³⁾ , 20, 25, 35,			
	821 / 822	1 750	66 100 – 180 000	49, 70, 100			

¹⁾ Other gear ratios on request

²⁾ Only for PS(K)F 121 / 521

³⁾ Only for PSBF 322 / 522



PS.C series

Features

- Planetary servo gear units
- Designed for nominal torques between 30 Nm and 320 Nm
- Provide the basis for diverse, dynamic, and above all, **cost-optimized drive solutions**
- Compact, lightweight design
- Any mounting position
- Life-long lubrication
- Four output variants:
 - PSC = B5 output, solid shaft
 - PSKC = 5 output, solid shaft with key
 - PSCZ = 14 output flange, solid shaft
 - PSKCZ = B14 output flange, solid shaft with key

Type	Size single-stage / two-stage	Torque class Nm	Overhung load range N	Gear unit ratios i	Rotational clearance (single-stage/double-stage)
					Standard
PS(K)C PS(K)CZ	221 / 222	30	1 170 – 2 000	single-stage	10' / 15'
	321 / 322	65	1 710 – 4 000	3 ¹⁾ , 5, 7, 10	
	521 / 522	160	2 900 – 6 750		
	621 / 622	320	5 390 – 11 000	two-stage 15 ¹⁾ , 21 ¹⁾ , 25, 30 ¹⁾ , 35, 49, 50, 70, 100	

¹⁾ Not for PS(K)C, PS(K)CZ 621 / 622

1.2 Servo gear units

Helical-bevel servo gear units



BS.F series

Features

- Low-backlash helical-bevel servo gear units
- Designed for torque classes 40 to 1 220 Nm
- 5 output variants:
 - BSF: Solid shaft
 - BSKF: Solid shaft with key
 - BSBF: Flange block shaft (EN ISO 9409)
 - BSHF: Hollow shaft with shrink disk
 - BSAF: Hollow shaft with key (shaft mounted gear unit)
- All variants with B5 mounting flange; foot-mounting and torque arm are optional (→ can be optimally integrated into the relevant application)
- The rotational clearance remains constantly low over the entire gear unit service life

Size	Torque class Nm	Gear unit ratios i	Rotational clearance `
202	40	3 / 4 / 6 / 8 / 10 / 15 / 20 / 25	6 ⁹⁾ / 3 ¹⁰⁾
302	80	3 / 4 / 6 / 8 / 10 / 15 / 20 / 25 / 30	
402	160		
502	320	3 / 4 / 6 / 8 / 10 / 12 / 15 / 20 / 25 / 30 / 35	
602	640	3 / 4 / 6 / 8 / 10 / 12 / 15 / 20 / 25 / 30 / 35 / 40	
802	1 220		

⁹⁾ Standard ¹⁰⁾ Reduced

Options for servo gear units

Direct motor mounting	Positive direct motor mounting (without terminal adapter) of the SEW servomotor series CMP.. and CM..
Motor adapter	EPH motor adapter for PS.F and PS.C planetary servo gear units, ECH motor adapter for PS.C planetary servo gear units and EBH motor adapter for BS.F helical-bevel servo gear units
Reduced backlash	Optionally for PS.F planetary servo gear units and BS.F helical-bevel servo gear units with significantly smaller rotational clearance
Minimized rotational clearance	Optionally for PS.F planetary servo gear units with even more reduced rotational clearance

- Accessories and options for servo gear units:**
- **Surface and corrosion protection: pages 78 – 80**

1.3 Stainless steel gear units

Stainless steel gear units



Features

- For use in areas subject to frequent cleaning:
 - Intralogistics
 - Hygienic applications
 - Food and beverage industry
 - Pharmaceutical industry
 - Permanently humid environments
- Low maintenance with long service life
- Efficiency-optimized gear units
- Available as KES37 helical-bevel gearmotors and RES37 helical gearmotors
- High-quality stainless steel is used
- Easy-to-clean surface thanks to special housing design
- High grade resistance to acid and alkaline
- As few indentations as possible where dirt or fluid could collect
- IEC and NEMA adapters, also made of stainless steel, allow for variable motor mounting

Type	Max. output torque Nm	Gear unit ratio i
KES37	200	3.98 – 106.38
RES37	200	3.41 – 134.83

Stainless steel gearmotor

Features	<ul style="list-style-type: none">– Compact, space-saving design as gearmotor for direct mounting– The entirely stainless steel design efficiently prevents all forms of corrosion– Directly mounted stainless steel motors are designed without fan so they can be cleaned easily and reliably
Motor power range kW	0.37 – 0.75 (Higher power ratings for adapter mounting are available upon request)

- ➔ **Accessories and options for stainless steel gear units:**
- **TorqLOC® hollow-shaft mounting system: page 81**

1.4 Explosion-proof gear units

Standard gear units



	Gear units comply with directive 94/9/EC (ATEX), equipment group II, category 2, II2GD design	Certified protection types
RX, R, RM series explosion-proof helical gear units	<ul style="list-style-type: none"> – For use on the European market – Accepted in China – Accepted in Russia in conjunction with EAC certificates (successor to GOST-R) 	<ul style="list-style-type: none"> – Protection type “c”: Protected by safe construction (design safety), EN13463-1 and -5 – Protection type “k”: Protected by liquid immersion, EN13463-1 and -8
F series parallel-shaft helical gear units		
K series helical-bevel gear units		
S series helical-worm gear units		
W series SPIROPLAN® right-angle gear units		

➔ **Technical data: pages 64 – 69**

Servo gear units



	Gear units comply with directive 94/9/EC (ATEX), equipment group II, category 2, II2GD design	Certified protection types
PS.F planetary servo gear units	<ul style="list-style-type: none"> – For use on the European market – Accepted in China – Accepted in Russia in conjunction with EAC certificates (successor to GOST-R) 	<ul style="list-style-type: none"> – Protection type “c”: Protected by safe construction (design safety), EN13463-1 and -5 – Protection type “k”: Protected by liquid immersion, EN13463-1 and -8
BS.F helical-bevel servo gear units		

➔ **Technical data: pages 70 + 72**

1.5 Accessories and options

Corrosion protection (KS) and surface protection (OS) for all standard gear units



Features	SEW-EURODRIVE offers optional corrosion and surface protection measures for operating motors and gear units under special environmental conditions; in combination, they ensure optimum protection of motors and gear units.
KS corrosion protection	KS corrosion protection measures for motors: <ul style="list-style-type: none"> – All retaining screws that are loosened during operation are made of stainless steel. – The nameplates are made of stainless steel. Various motor parts are coated with a finishing varnish. – The flange contact surfaces and shaft ends are treated with a temporary rust preventive. – Band clamps as additional measures for brakemotors.
OS surface protection	Motors and gear units are optionally available with surface protection OS1, OS2, OS3 or OS4 instead of the standard surface protection. This makes the gearmotors well equipped for operation under various ambient conditions.

Measures for interior treatment and standard parts

Special interior surface coating



Brakes with pressure plate made of non-corrosive material



Rustproof nameplates



Non-corrosive retaining parts



RS bearing for IP56



Special interior surface coating



Special interior surface coating



Rustproof breather valves



NOCO® fluid, the contact corrosion inhibitor







Output shaft made of stainless steel



Optional coating at drive shaft end (in the area of the radial oil seal seat)







Surface protection (OS)

Surface protection		Ambient conditions/sample applications
Standard		<p>For machines and systems within buildings and interior rooms with neutral atmospheres.</p> <ul style="list-style-type: none"> – C1 (negligible)* <p>Sample applications:</p> <ul style="list-style-type: none"> – Machines and systems in the automobile industry – Conveyor systems in logistics areas – Conveyor belts at airports
OS1		<p>For environments prone to condensation and atmospheres with low humidity or contamination, such as outdoor applications under a roof or protective equipment.</p> <ul style="list-style-type: none"> – C2 (low)* <p>Sample applications:</p> <ul style="list-style-type: none"> – Systems in saw mills – Hall gates – Agitators and mixers
OS2		<p>For environments with high humidity or moderate atmospheric contamination, such as outdoor applications subject to direct weathering.</p> <ul style="list-style-type: none"> – C3 (moderate)* <p>Sample applications:</p> <ul style="list-style-type: none"> – Applications in amusement parks – Funiculars and chair-lifts – Applications in gravel plants – Systems in nuclear power plants
OS3		<p>For environments with high humidity and occasionally severe atmospheric and chemical contamination. Occasional acidic or caustic wet cleaning. Also for applications in coastal areas with moderate salt load.</p> <ul style="list-style-type: none"> – C4 (high) * <p>Sample applications:</p> <ul style="list-style-type: none"> – Sewage treatment plants – Port cranes – Mining applications
OS4		<p>For environments with permanent humidity and severe atmospheric or chemical contamination. Regular acidic and caustic wet cleaning, also with chemical cleaning agents.</p> <ul style="list-style-type: none"> – C5-I (severe) * <p>Sample applications:</p> <ul style="list-style-type: none"> – Drives in malting plants – Wet areas in the beverage industry – Conveyor belts in the food industry

1.5 Accessories and options

Surface protection (OS)

Surface protection		Ambient conditions/sample applications
Aseptic motors of the DAS.. series Either OS2–OS4		Suitable for dry or wet hygienic areas with average atmospheric contamination. Also suitable for particularly dusty environments. <ul style="list-style-type: none"> – C3 (moderate)* Sample applications: <ul style="list-style-type: none"> – Applications in clean rooms – Machines in the cosmetic and pharmaceutical industry – Systems for processing cereals and flour (without Ex protection) – Conveyor belts in cement plants
Aseptic motors of the DAS.. series with drive package ASEPTICplus® OS4		For hygienic areas in the food and beverage industry with permanent humidity, regular acidic or caustic wet cleaning with chemical agents and pressure cleaning. <ul style="list-style-type: none"> – C5-I (severe) * Sample applications: <ul style="list-style-type: none"> – Hygienic and aseptic conveyors in the beverage industry – Systems in cheese dairies and meat processing plants – “Splash zones” in the food industry
High protection surface treatment HP200		For hygienic areas in the food and beverage industry with regular acidic and caustic wet cleaning. Anti-stick Features support the cleaning process even in inaccessible areas. Sample applications: <ul style="list-style-type: none"> – Hygienic and aseptic conveyors in the beverage industry – Systems in cheese dairies and meat processing industries – “Splash zones” in the food industry
Stainless steel gearmotor		For hygienic areas in the food and beverage industry with permanent humidity and extreme acidic and caustic wet cleaning using chemical cleaning agents. Sample applications: <ul style="list-style-type: none"> – Hygienic and aseptic applications of all types – Systems in cheese dairies and meat processing industries – Food processing machines for the North American market

* In accordance with the corrosivity categories of DIN EN ISO 12944-2

TorqLOC® hollow shaft mounting system



Cost efficient	The TorqLOC® hollow shaft mounting system is used for achieving a non-positive connection between customer shaft and hollow shaft in the gear unit, optional for parallel-shaft helical, helical-bevel or helical-worm gear units. An economic alternative to the previous hollow shaft with shrink disk, hollow shaft with key, and splined hollow shaft.
Simple	The drive can be installed and removed easily, even after long periods of operation. The drive is delivered with the matching bushing. The operator will install the clamping ring on the customer shaft and the drive can be mounted and fixed easily.
Economical	The TorqLOC® hollow shaft mounting system makes it possible to use drawn, unprocessed material up to quality level h11 for customer shafts, reducing costs even further. No additional machining of the customer shaft is required.
Flexible	Up to 4 different rated diameters can be adapted with one gear unit size.
Awards	The trade journal "Plant Engineering" awarded the "Product of the Year 2002". The award is given to innovative products which lead to ground-breaking improvements at the production level.

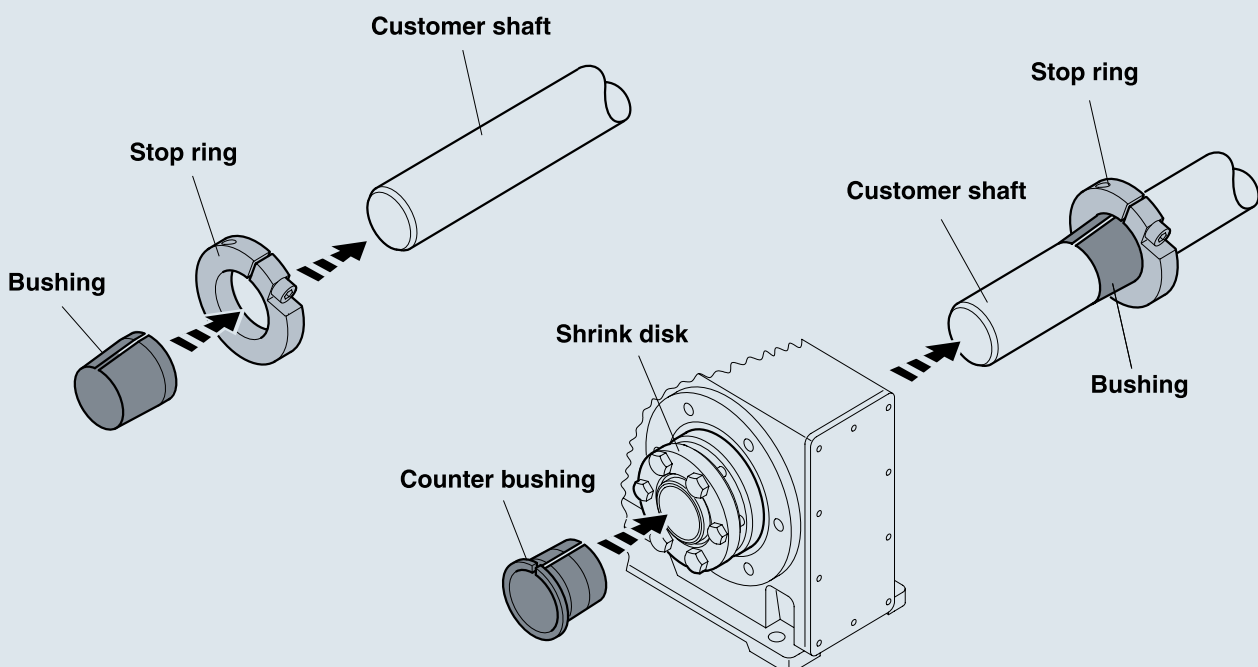

02 GEARMOTORS

2.1 Standard gearmotors

Helical gearmotors, RX../R..DR.. series	84
Parallel-shaft helical gearmotors, F..DR.. series	85
Helical-bevel gearmotors, K..DR.. series	85
Helical-worm gearmotors, S..DR.. series	86
SPIROPLAN® right-angle gearmotors, W..DR.. series	87

2.2 Electrified monorail system gearmotors

Light loads, HW series	88
Heavy loads, HK series	89

2.3 Variable speed gearmotors

VARIBLOC® (wide V-belt)	90
VARIMOT® (friction disks)	91

2.4 Servo gearmotors

Planetary servo gearmotors, PS.F..CMP.. / PS.C..CMP.. series	92
Helical-bevel servo gearmotors, BS.F.. CMP.. series	93
Helical servo gearmotors, RX../R.CMP.. series	93
Parallel-shaft helical servo gearmotors, F..CMP.. series	94
Helical-bevel servo gearmotors, K..CMP.. series	95
Helical-worm servo gearmotors, S..CMP.. series	96
SPIROPLAN® right-angle servo gearmotors, W..CMP.. series	97

2.5 Stainless steel gearmotors

Helical gearmotors, RES.. series	98
Helical-bevel gearmotors, KES.. series	98

2.6 Explosion-proof gearmotors

Helical gearmotors, RX../R..EDR.. series	99
Parallel-shaft helical gearmotors, F..EDR.. series	99
Helical-bevel gearmotors, K..EDR.. series	99
Helical-worm gearmotors, S..EDR.. series	99
SPIROPLAN® right-angle gearmotors, W..EDR.. series	99
Planetary servo gearmotors, PS.F..CMP.. series	101
Helical-bevel servo gearmotors, BS.F..CMP.. series	101
Helical servo gearmotors, R..CMP.. series	101
Parallel-shaft helical servo gearmotors, F..CMP.. series	101
Helical-bevel servo gearmotors, K..CMP.. series	101
Helical-worm servo gearmotors, S..CMP.. series	101
SPIROPLAN® right-angle servo gearmotors, W..CMP.. series	101



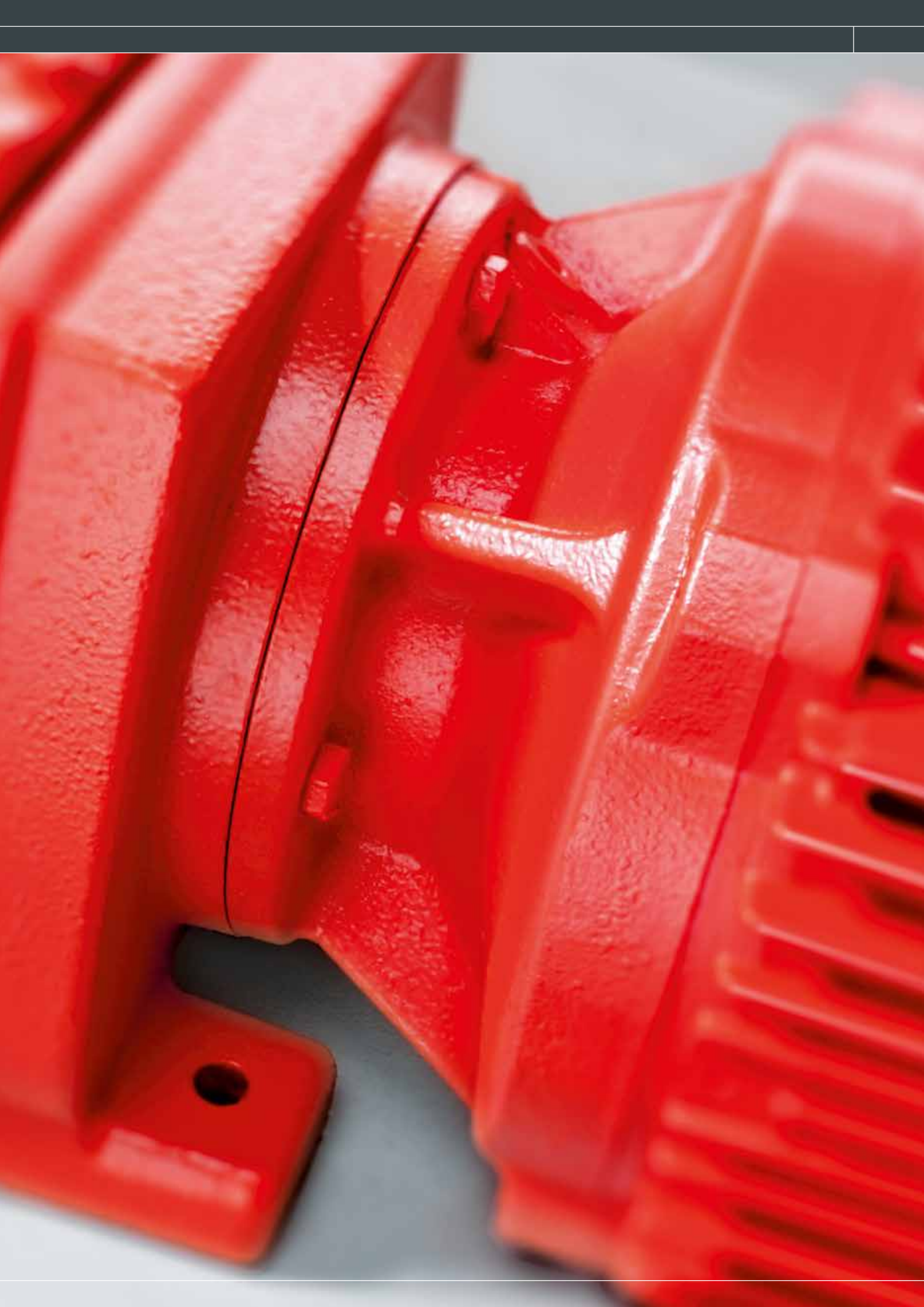

2.1 Standard gearmotors

Helical gearmotors



RX series (single-stage)

Gear unit		Motor	
Gear unit sizes	$M_{a,max}$ gear unit Nm	Efficiency class	Power rating kW
RX57 – RX107	69 – 830	–, with 4-pole DR63 motor	0.12 – 0.25
		IE1, with 4-pole DRS.. motor	0.18 – 55
		IE2, with 4-pole DRE.. motor	0.37 – 45
		IE3, with 4-pole DRN../DRP.. motor	0.75 – 55
		IE4, with 4-pole DRU.. motor	0.18 – 3



R series (two-stage and three-stage)

Gear unit		Motor	
Gear unit sizes	$M_{a,max}$ gear unit Nm	Efficiency class	Power rating kW
R07 – R167	50 – 18 000	–, with 4-pole DT56/DR63 motor	0.09 – 0.25
		IE1, with 4-pole DRS.. motor	0.18 – 200
		IE2, with 4-pole DRE.. motor	0.37 – 200
		IE3, with 4-pole DRN../DRP.. motor	0.75 – 200
		IE4, with 4-pole DRU.. motor	0.18 – 3

Parallel-shaft helical gearmotors



F series (two-stage and three-stage)

Gear unit		Motor	
Gear unit sizes	Ma _{max} gear unit Nm	Efficiency class	Power rating kW
F27 – F157	130 – 18 000	–, with 4-pole DR63 motor	0.12 – 0.25
		IE1, with 4-pole DRS.. motor	0.18 – 200
		IE2, with 4-pole DRE.. motor	0.37 – 200
		IE3, with 4-pole DRN../DRP.. motor	0.75 – 200
		IE4, with 4-pole DRU.. motor	0.18 – 3

Helical-bevel gearmotors



K series (two-stage / three-stage)

Gear unit		Motor	
Gear unit sizes	Ma _{max} gear unit Nm	Efficiency class	Power rating kW
K19 – K187	80 – 50 000	–, with 4-pole DR63 motor	0.12 – 0.25
		IE1, with 4-pole DRS.. motor	0.18 – 200
		IE2, with 4-pole DRE.. motor	0.37 – 200
		IE3, with 4-pole DRN../DRP.. motor	0.75 – 200
		IE4, with 4-pole DRU.. motor	0.18 – 3

2.1 Standard gearmotors

Helical-worm gearmotors



S series (two-stage)

Gear unit		Motor	
Gear unit sizes	$M_{a,max}$ gear unit Nm	Efficiency class	Power rating kW
S37 – S97	92 – 4 000	–, with 4-pole DR63 motor	0.12 – 0.25
		IE1, with 4-pole DRS.. motor	0.18 – 45
		IE2, with 4-pole DRE.. motor	0.37 – 45
		IE3, with 4-pole DRN../DRP.. motor	0.75 – 37

SPIROPLAN® right-angle gearmotors



W series (single-stage / two-stage)

Gear units		Motor	
Gear unit sizes	Ma _{max} gear unit Nm	Efficiency class	Power rating kW
W10 – W47	25 – 180	–, with 4-pole DT56/DR63 motor	0.09 – 0.25
		IE1, with 4-pole DRS.. motor	0.18 – 5.5
		IE2, with 4-pole DRE.. motor	0.37 – 4
		IE3, with 4-pole DRN../DRP.. motor	0.75 – 4
		IE4, with 4-pole DRU.. motor	0.18 – 2.2

- ➔ **Accessories and options for standard gearmotors:**
- Surface and corrosion protection: pages 78 – 80
 - TorqLOC® hollow shaft mounting system: page 81

2.2 Electrified monorail system gearmotors

HW series – light load range



HW series

Features

- Compliance with the standards of the C1 Directive (VDI RL-3643)
- Low maintenance
- Smooth running for operation without vibration
- Low-noise, also suitable for manual work stations
- Compact design for space-saving installation

Size	HW10	HW30
Maximum output torque Nm	20	70
Permitted wheel load N	2 500	5 600
Gear ratio i	6.75 – 16.5	8.2 – 75
Shaft d x l mm	14 x 28	20 x 35 25 x 35

HK series – heavy load range



HK series

Features	<ul style="list-style-type: none"> – High efficiency due to the helical-bevel gear unit – Low energy consumption in connection with the MOVITRANS® contactless energy transfer system – Can be switched safely thanks to clutch in the gear unit output stage 			
Size	HK37	HK40	HK50	HK60
Maximum output torque Nm	220	400	600	820
Permitted wheel load N	14 500	18 500	25 000	40 000
Gear ratio i	13.08 – 106.38	12.2 – 131.87	13.25 – 145.14	13.22 – 144.79
Shaft d x l mm	25 x 35	30 x 60 35 x 70	45 x 90	55 x 110

➔ **Accessories and options for electrified monorail system gearmotors:**
Surface and corrosion protection: pages 78 – 80

2.3 Variable speed gearmotors

Wide V-belt variable speed gearmotors



VARIBLOC®

Wide V-belt variable speed gearmotors

Features

- U-shaped or Z-shaped power flow
- Several combination options with reduction gear units
- Easy adaptation to a wide variety of machine designs
- The foot-mounted and flange-mounted designs can also be used without reduction gear unit as machine drive
- Can be combined with motors from the modular system, meeting the requirements of the efficiency classes IE1, IE2, and IE3
- Flexible due to finely stepped gear ratio ranges of the reduction gear units per size
- Easy to operate with handwheel or remote control

VARIBLOC® size	Max. motor power 4-pole			Possible power flow	Max. setting range for design	
	IE1 kW	IE2 kW	IE3 kW		Ventilated	Non-ventilated
VU / VZ 01	0.55	–	0.75	U + Z	1:6	–
VU / VZ 11	1.1	0.75	1.5	U + Z	1:8	1:6
VU / VZ 21	3	2.2	3	U + Z	1:8	1:6
VU / VZ 31	5.5	4	4	U + Z	1:8	1:6
VU / VZ 41	11	9.2	-	U + Z	1:6	1:4
VU 51	22	22	-	only U	1:6	–
VU 6	45	45	-	only U	1:4	–

Friction disk variable speed gearmotors



VARIMOT®

Friction disk variable speed gearmotors

Features

- The contact pressure between the drive pulley and the friction ring required for torque transmission is set automatically
- The speed can be adjusted even at standstill
- The foot-mounted and flange-mounted designs can also be used without reduction gear unit as machine drive
- Can be combined with motors from the modular system, meeting the requirements of the efficiency classes IE1, IE2, and IE3
- Flexible due to finely stepped gear ratio ranges of the reduction gear units per size
- Easy to operate with handwheel or remote control

VARIMOT® Size	Max. motor power rating kW	Max. setting range
D16	1.1	1:5
D26	2.2	1:5

➔ **Accessories and options for variable speed gearmotors:**
Surface and corrosion protection: pages 78 – 80

2.4 Servo gearmotors

Planetary servo gearmotors



PS.F. series

with	Torque range M_{aDyn} Nm	PS.F. gear unit sizes
CMP.. motor (high dynamics)	15 – 4 200	PS.F121 – PS.F922
CM.. motor (high inertia)	49 – 4 200	PS.F321 – PS.F922



PS.C.. series

with	Torque range M_{aDyn} Nm	PS.C.. gear unit sizes
CMP.. motor (high dynamics)	15 – 425	PS.C221 – PS.C622
CM.. motor (high inertia)	49 – 425	PS.C321 – PS.C622

Helical-bevel servo gearmotors



BS.F. series

with	Torque range M_{aDyn} Nm	BS.F. gear unit sizes
CMP.. motor (high dynamics)	15 – 1 680	BS.F202 – BS.F802
CM.. motor (high inertia)	46 – 1 680	BS.F302 – BS.F802

Helical servo gearmotors



RX/R series

Features	<ul style="list-style-type: none"> – The RX57 to RX107 single-stage gear unit series offers compact, space-saving solutions for high output speeds – Thanks to the die-cast aluminum design, multi-stage gear units R07, R17 and R27 are ideal for use as satellite drives and for use in light machine constructions 					
	Synchronous servo gearmotors				Asynchronous servo gearmotors	
	with CMP.. motor (high dynamics)		with CM.. motor (high inertia)		with DRL.. motor	
Gear unit size	RX57 – RX77	R07 – R107	RX57 – RX107	R27 – R107	RX57 – RX107	R17 – R167
Gear ratios i	1.3 – 7.63	3.21 – 216.54	1.3 – 8.23	3.37 – 216.28	1.3 – 8.23	3.37 – 255.71
Torque range M_{aDyn} Nm	6.6 – 1 120	12 – 4 360	63 – 830	45 – 4 300	63 – 830	45 – 18 000
Rotational clearance (/R option)	–	5 – 14	–	5 – 14	–	5 – 14

2.4 Servo gearmotors

Parallel-shaft helical servo gearmotors



F series

Features	– This compact gearmotor not only excels by its performance but also by its structural Features		
	Synchronous servo gearmotors		Asynchronous servo gearmotors with DRL.. motor
	with CMP.. motor (high dynamics)	with CM.. motor (high inertia)	
Gear unit size	F27 – F107	F27 – F107	F27 – F157
Gear ratios i	3.77 – 276.77	3.77 – 276.77	3.77 – 276.77
Torque range M_{aDyn} Nm	15 – 8 860	67 – 8 860	87 – 18 000
Rotational clearance (/R option)	5 – 12	5 – 12	5 – 12

Helical-bevel servo gearmotors



K series

Features

- Helical-bevel gear units from SEW-EURODRIVE provide a high degree of efficiency in both torque directions and at any input speed
- The gearing is designed for high endurance and makes for a high-torque, wear-free drive
- The remarkably high efficiency of the helical-bevel gearmotors of SEW-EURODRIVE makes them energy savers
- The long maintenance-free service life is another reason why they can be used with AC asynchronous motors, asynchronous and synchronous servomotors in every application

	Synchronous servo gearmotors		Asynchronous servo gearmotors		
	with CMP.. motor (high dynamics)	with CM.. motor (high inertia)	with DRL.. motor		
Gear unit size	K37 – K107	NEW: K..19 – K..49	K37 – K107	K37 – K187	NEW: K..19 – K..49
Gear ratios i	3.98 – 174.19	2.8 – 75.0	3.98 – 176.05	3.98 – 179.86	2.8 – 75.20
Torque range M_{aDyn} Nm	15 – 9 090	16 – 605	63 – 9 090	125 – 50 000	54 – 605
Rotational clearance (/R option)	5 – 13	–	5 – 13	5 – 13	–

2.4 Servo gearmotors

Helical-worm servo gearmotors



S series

Features

- Particularly space-saving when used as angular drive
- The attenuation characteristics are another advantage
- Torque shocks are attenuated as the power transmission to the drive shaft is linear on the input shaft
- The noise level of this type is very low, even when operating the unit at full capacity
- Can be used in stage lifts, for example

	Synchronous servo gearmotors		Asynchronous servo gearmotors with DRL.. motor
	with CMP.. motor (high dynamics)	with CM.. motor (high inertia)	
Gear unit size	S37 – S67	S37 – S67	S37 – S67
Gear ratios i	3.97 – 75.06	6.80 – 75.06	3.97 – 75.06
Torque range M_{aDyn} Nm	18 – 580	43 – 480	32 – 480

SPIROPLAN® right-angle servo gearmotors



W series

Features

- SPIROPLAN® right-angle servo gearmotors with directly mounted synchronous CMP.. servomotor are extremely efficient, quiet, and offer customers the greatest possible flexibility
- SPIROPLAN® right-angle gear units W37 / W47 achieve high speeds at smallest gear ratios
- Wear-free gearing minimizes friction losses and optimize the mechanical efficiency
- Areas of application: Ideal drives for simple positioning or conveyor applications
- Gear unit designs:
 - Foot/flange-mounted design
 - B5 flange
 - B14 flange
 - Solid shaft / hollow shaft
 - Directly mounted servomotor
 - Adapter mounting

	Synchronous servo gearmotors		Asynchronous servo gearmotors with DRL.. servomotor
	with CMP. motor (high dynamics)	with CM.. motor (high inertia)	
Gear unit size	W37 – W47	W37 – W47	W37 – W47
Gear ratios i	3.2 – 74.98	3.2 – 51.12	3.2 – 74.98
Torque range M_{aDyn} Nm	11 – 215	49 – 215	16 – 215

- ➔ **Accessories and options for servo gearmotors:**
Surface and corrosion protection: pages 78 – 80
TorqLOC® hollow shaft mounting system: page 81

2.5 Stainless steel gearmotors



Features of stainless steel gear units	<ul style="list-style-type: none"> – For use in areas subject to frequent cleaning – High-quality stainless steel is used – Efficiency optimized gear units – Easy-to-clean surface thanks to special housing design – Low maintenance with long service life – High grade resistance to acid and alkaline – As few indentations as possible where dirt or fluid could collect 	
Type	KES37	RES37
Max. output torque Nm	200	200
Gear unit ratio i	3.98 – 106.38	3.41 – 134.83
Features of stainless steel gearmotors	<ul style="list-style-type: none"> – Compact, space-saving design as gearmotor for direct mounting – The entirely stainless steel design efficiently prevents all forms of corrosion – The design without fan allows for easy and reliable cleaning of the directly mounted stainless steel motors. 	
Motor power range kW	0.37 – 0.75 (Higher power ratings for adapter mounting are available upon request)	

➔ **Accessories and options for stainless steel gearmotors:**
TorqLOC® hollow shaft mounting system: page 81

2.6 Explosion-proof gearmotors

Explosion-proof standard gear units



Helical gear units, RX, R series	Comply with directive 94/9/EC (ATEX), equipment group II, category 2, II2GD design – For use on the European market – Accepted in China – Accepted in Russia in conjunction with EAC certificates (successor to GOST-R)
Parallel-shaft helical gear units, F series	
Helical-bevel gear units, K series	
Helical-worm gear units, S series	
SPIROPLAN® right-angle gear units, W series	Certified protection types – Protection type “c”: Protected by safe construction (design safety), EN13463-1 and -5 – Protection type “k”: Protected by liquid immersion, EN13463-1 and -8
Planetary servo gearmotors, PS.F.CMP. / PS.C.CMP. series	Comply with directive 94/9/EC (ATEX), equipment group II and equipment category 3. The combinations are available in II3GD and II3D design.
Helical-bevel servo gearmotors, BS.F.CMP. series	
Helical servo gearmotors, R.CMP. series	
Parallel-shaft helical servo gearmotors, F.CMP. series	
Helical-bevel servo gearmotors, K.CMP. series	
Helical-worm servo gearmotors, S.CMP. series	
SPIROPLAN® right-angle servo gearmotors, W.CMP. series	

2.6 Explosion-proof gearmotors

Explosion-proof motors



EDR.. series (AC motor)

Compliant with EC Directive 94/9/EC (ATEX) and IECEx

- Can be used in categories 2G, 2GD and 3GD, 3D for zones 1 / 21 and 2 / 22
- Also available as brakemotor in category 3
- Conform to the efficiency class IE2
- In accordance with IECEx to EPL Gb and Db as well as Gc and Dc
- EDRS and EDRE motor types are audited and certified to IECEx “Certified Equipment Scheme” with ExTr, QAR und CoC by PTB; For detailed information on the certification system, refer to International Electrotechnical Commission
- Operation on a frequency inverter, also in field weakening operation, for categories 2 and 3 and/or EPL.b and .c

According to HazLOC-NA® (NEC500/C22.1)

- Motors are certified according to the Class Division System and therefore meet the explosion protection requirements for the North American market
- Available as CID2 type, for Division 2 Class I for gas groups A, B, C and D
- Available as CIID2 type, Division 2 Class II for dust groups F and G
- Available as type /CICIID2, for Division 2 Class I for gas groups A, B, C and D and Class II for dust groups F and G
- Also available as brakemotor
- Operation with frequency inverter possible

CMP.. series (synchronous servomotor)

Compliant with directive 94/9/EC (ATEX), equipment group II, equipment category 3

- Category II 3GD, for use in zones 2 / 22
- Category II 3D, for use in zone 22
- Also available with brake and Hiperface® encoder (with electronic nameplate) in category 3D

Explosion-proof standard gearmotors



Gear unit	EDR.. motor	
Gear unit sizes	Ma_{max} gear unit Nm	Power rating kW
Helical gearmotors RX57 – RX107 (single-stage)	69 – 830	0.12 – 45
R07 – R167 helical gearmotors (two- and three-stage)	50 – 18 000	0.12 – 45
F27 – F157 parallel-shaft helical gearmotors (two- and three-stage)	130 – 18 000	0.12 – 45
K37 – K187 helical-bevel gearmotors (three-stage)	200 – 50 000	0.12 – 45
S37 – S97 helical-worm gearmotors (two-stage)	92 – 4 000	0.12 – 45
W20 – W47 SPIROPLAN® right-angle gearmotors (single-stage and two-stage)	40 – 180	0.12 – 4

Explosion-proof servo gearmotors



Gear unit	With CMP.. motor (high dynamics)
Gear unit sizes	Torque range M_{adyn} Nm
Planetary servo gearmotors PS.F121 – PS.F922	15 – 4 200
Helical-bevel servo gearmotors BS.F202 – BS.F802	15 – 1 680
Helical servo gearmotors RX57 – RX107	6.6 – 910
Helical servo gearmotors R07 – R107	12 – 4 360
Parallel-shaft helical servo gearmotors F27 – F107	15 – 8 860
Helical-bevel servo gearmotors K37 – K107	15 – 9 090
Helical-worm servo gearmotors S37 – S67	18 – 580
SPIROPLAN® right-angle servo gearmotors W10 – W47	12 – 215

03 MOTORS

3.1 AC motors

DR.. AC motor / NEW: DRN.. series	104
DR...J AC motors with LSPM technology	108
DRM.. torque motors	110
NEW: DRK.. single-phase motors	111
Excerpt of additional versions	112
DAS.. aseptic motors	114
EDR.. explosion-proof motors	116

3.2 Servomotors

CMP.. series synchronous servomotors (high dynamics)	122
CM.. series synchronous servomotors (high inertia)	124
DRL.. series asynchronous servomotors	125
Explosion-proof CMP.. series servomotors	126
Cables and connection options	128

3.3. Linear motion

SL2 synchronous linear servomotors	130
Standard CMS.. electric cylinders and modular CMSM.. electric cylinders	131

3.4 Accessories and options

Brakes and brake control	138
NEW: BF../BT.. double brake	139
Built-in encoder	140
Surface and corrosion protection	141



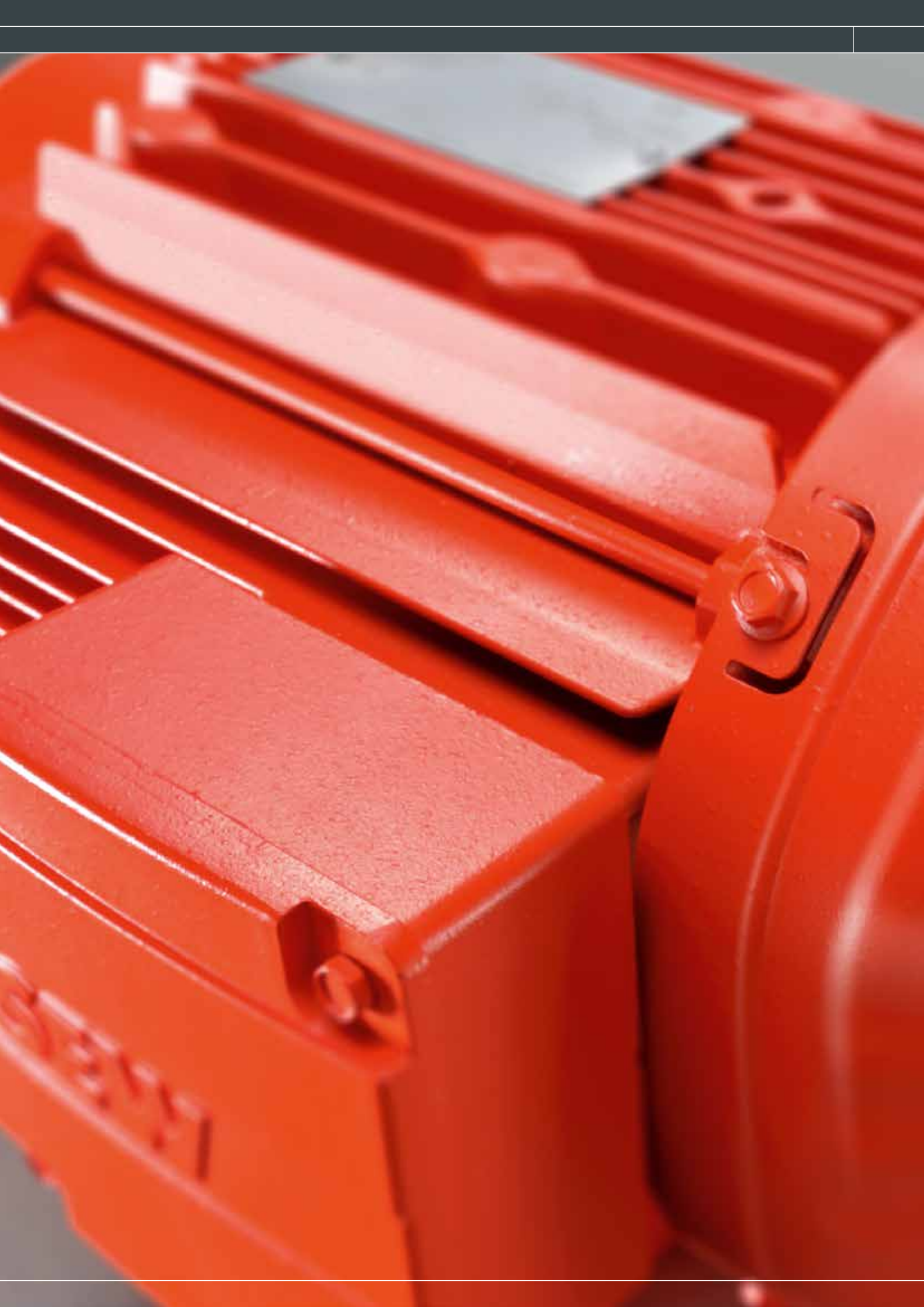

3.1 AC motors

DR.. series AC motors



Standard AC motors in efficiency classes IE1 to IE4

Features

- DR.. motors support all standards worldwide and fulfill the requirements of the IEC 60034-30-1 motor standard
- Independent of the required efficiency class, the whole range of DR.. motor options or variants is available for all efficiency classes
- The new modular DR.. motor system series offers:
 - The four energy-efficient motor variants IE1, IE2, IE3 and IE4 according to IEC 60034-30-1
 - A perfect brake concept, i.e. up to three different brake sizes for each motor size
 - Cost-optimized built-in encoders integrated in the motor
 - Significant time savings thanks to optimized motor selection, ordering, and logistics processes

IE class	Number of poles	Motor type	With 50 Hz frequency	With 60 Hz and 50/60 Hz frequency	
			Power rating kW	Power rating kW	Power rating hp
Without IE classification	2-pole	DR63..	0.18 – 0.37	0.18 – 0.37 (60 Hz)	0.25 – 0.5
	4-pole	DT56.. / DR63..	0.09 – 0.25	0.09 – 0.25 (60 Hz)	0.1 – 0.34
	6-pole	DR63..	0.09 – 0.18	0.09 – 0.18 (60 Hz)	0.1 – 0.25
IE1	2-pole	DRS.. Sizes 71 – 315	0.37 – 9.2	0.37 – 9.2	0.5 – 12.5
	4-pole		0.18 – 200	0.18 – 225	0.25 – 300
	6-pole		0.18 – 7.5	0.18 – 7.5	0.25 – 10
IE2	2-pole	DRE.. Sizes 71 – 315	0.75 – 9.2	0.75 – 7.5	1 – 10
	4-pole		0.25 – 200	0.25 – 225	0.34 – 300
	6-pole		0.25 – 5.5	0.75 – 5.5	1 – 7.5
IE3	2-pole	DRP.. Sizes 80 – 132	0.75 – 5.5	0.75 – 5.5	1 – 7.5
	4-pole	DRN.. Sizes 80 – 315	0.75 – 200	0.75 – 200	1 – 275
	6-pole	DRP.. Sizes 90 – 160	0.75 – 4	0.75 – 4	1 – 5.5
IE4	4-pole	DRU...J Sizes 71 – 100	0.18 – 3	–	–

Energy efficiency marks	IE1 Standard Efficiency	IE2 High Efficiency	IE3 Premium Efficiency	IE4 Super Premium Efficiency
	International: IE1 EU Europe: IE1 Switzerland: IE1 Japan: JIS/IE1	International: IE2 EU Europe: IE2 Switzerland: IE2 Turkey: IE2 Canada: EER USA: ee Brazil: ENCE PR China: Grade 3 South Korea: KEL	International: IE3 EU Europe: IE3 Switzerland: IE3 Turkey: IE3 Canada: EER USA: ee Brazil: ENCE PR China: Grade 2 Japan: JIS/IE3	International: IE4 EU Europe: IE4 Switzerland: IE4 Turkey: IE4 Canada: EER PR China: Grade 1

Excerpt from the technical description

Voltage range DRS../DRE.. motors	220 – 242 / 380 – 420 V or 380 – 420 / 660 – 725 V	254 – 277 / 440 – 480 V or 440 – 480 V
Voltage range NEW: DRN.. motors	220 – 230 / 380 – 400 V or 380 – 400 / 660 – 690 V	254 – 260 / 440 – 460 V or 440 – 460 V
Frequency	50 Hz	60 Hz
Power rating	4-pole: DRS..: 0.18 kW (0.25 hp) – 0.55 kW (0.75 hp) DRE..: 0.75 kW (1.0 hp) – 5.5 kW (7.5 hp) NEW: DRN..: 0.75 kW (1.0 hp) – 200 kW (275 hp) In “global motor” design, 2 and 6-pole motors are also available. Feel free to contact us.	
Energy efficiency specifications on the nameplate	<ul style="list-style-type: none"> – IE classification with numerical value of efficiency during line operation for 50 and 60 Hz – USA: ee label (by DoE, Department of Energy, EISA 2007) – Canada: CSA (Energy Verified) label (EER 2010) – China: CEL label (GB 18613) – Brazil: ENCE label – South Korea: KEL label according to REELS 2010 	
Additional information on the nameplate	<ul style="list-style-type: none"> – According to US design specification NEMA MG1 <ul style="list-style-type: none"> - TEFC, TEBC, TENV depending on ventilation type - K.V.A. code, code letter of the short circuit apparent power - M.L. (Mounting Location), four-digit code for UL-registered mounting location - Design code, code letters for startup and breakdown torque and starting current ratio – Temperature range, according to the Canadian design specification CSA C22.2, SEW-EURODRIVE approval up to + 40°C, efficiency level to CSA C390, specifications for operation on a frequency inverter – Conformity and certification logo for <ul style="list-style-type: none"> - Europe: CE marking - USA: UR marking - Canada: CSA label - China: CCC label, if necessary - EAC: Eurasian conformity 	
Further information	<p>Also observe the DR...J motor designs for IE2, IE3, and IE4 (LSPM technology on pages 108 + 109).</p> <p>Observe the changes in regulation 640/2009 for Europe and other planned changes of the energy efficiency laws/regulations after January 1, 2015.</p>	

3.1 AC motors

DR.. series AC motors



Voltages and energy efficiency classes that differ around the world, but nevertheless just one motor

Features

- With the 50/60 Hz specifications and the inclusion of the elements that are typically required for a country on the nameplate, motors of the DRS.., DRE.. and **NEW** DRN.. series offer the unique possibility of unifying many different designs in one drive
- Thanks to its large voltage range, it is possible to achieve different voltages anywhere in the world with one motor
- This “global motor” of SEW-EURODRIVE complies with various international standards, especially IEC EN 60034, NEMA MG1, CSA C22.2, ABNT, NCh 3086 and to the energy efficiency regulations in Europe: Directive 2009/125/EC (ErP), USA: EISA 2007, Canada: EER, Brazil: PN 553, China: GB 18613
- Significant time savings thanks to optimized processes in motor selection, order processing, and logistics

The regulations of many countries have exceptions for gearmotors, brakemotors and Ex motors among others. For detailed and up-to-date information, refer to www.ie-guide.com/en/ieguide

		Line voltage (3x...)	Line frequency	Currently	Efficiency class	In the future	Efficiency class	Use of "global motor" IE3
Europe (EEA)		400 V	50 Hz	January 01, 2015	– From 7.5 kW: IE3 or IE2 operated with FI – From 0.75 kW: IE2	January 01, 2017	From 0.75 kW: IE3 or IE2 with FI	Yes
Switzerland		400 V	50 Hz	January 01, 2015	– From 7.5 kW: IE3 or IE2 operated with FI – From 0.75 kW: IE2	January 01, 2017	From 0.75 kW: IE3 or IE2 with FI	Yes
Turkey		380 V 400 V	50 Hz	January 01, 2015	– From 7.5 kW: IE3 or IE2 operated with FI – From 0.75 kW: IE2	January 01, 2017	From 0.75 kW: IE3 or IE2 with FI	Yes
USA		480 V	60 Hz	December 19, 2010	– Up to 150 kW: Premium (~IE3) – > 150 kW: High (~IE2)	June 01, 2016	Premium (~IE3)	Yes
Canada		480 V 575 V	60 Hz	January 01, 2011	– Up to 150 kW: Premium (~IE3) – > 150 kW: High (~IE2)	No changes known		Yes
Brazil		220 V 380 V 440 V	60 Hz	December 01, 2009	IR2 (~IE2)	Under discussion (2018)	IR3 (~IE3)	Yes
Australia / New Zealand	 	400 V 415 V	50 Hz	2006	IE2	Under discussion (2016)	IE3	Yes
South Korea		220 V 380 V 440 V	60 Hz	July 01, 2010	IE2	Under discussion (2015-2017)	IE3	
China		380 V	50 Hz	September 01, 2012	Grade 3 (~IE2)	Under discussion (2016/2017)	Grade 2 (~IE3)	Yes
India		415 V	50 Hz	July 31, 2014	IE3 (voluntary certification)	No changes known		
Chile		380 V	50 Hz	January 04, 2011	Up to 7.5 kW: IE1	No changes known		Yes
Mexico		440 V	60 Hz	December 19, 2010	IE3	No changes known		Yes
Japan		200 V 400 V 220 V 440 V	50/60 Hz 60 Hz	April 01, 2015	IE3	No changes known		

3.1 AC motors

DR...J series AC motors (LSPM* technology)



DR.. series:

DR...J design (LSPM* technology)

***Line Start Permanent Magnet Motor**

Features

- The **DR..J** synchronous motor design (LSPM technology) is integrated in the DR.. series modular motor system and is designed in the sizes 71S to 100L. The technology is based on adding permanent magnets below the squirrel cage of AC asynchronous motors
- One motor – three variants – three energy efficiency classes:
- DR...J motors are available in the energy-efficient designs DRE..J (IE2), DRP..J (IE3) and DRU..J (IE4) with LSPM technology
- This is indicated by a “J” following the length designation
- Compared to series motors with the same power range, the same energy efficiency class is achieved with a smaller size of the DR...J motors (LSPM technology)
- Compact and robust design
- Synchronous running of the motors with operating frequency
- Slip-free speed control without encoder feedback
- No rotor losses occur during operation:
 - High efficiency from IE2 to IE4
 - Compact design compared to standard asynchronous motors
- DR.. J LSPM motors can be operated with the frequency inverters MOVITRAC® LTP-B, MOVITRAC® B, MOVIFIT® FC, and MOVIMOT® D
- Can be used as individual or group drive with a frequency inverter
- Many additional features of the modular motor system are available
- Can be combined with the 7-series of the modular gear unit system from SEW-EURODRIVE
- Constant torque CT in the speed setting range without forced cooling fan

Technical data

Frequency inverter operation / 50 Hz

Constant torque from 300 to 1 500 rpm CT 1:5

Design	Efficiency class	Size	Power rating P _N kW
DRE..J	IE2	71S – 100M	0.37 – 4.0
DRP..J	IE3	71S – 100L	0.37 – 4.0
DRU..J	IE4	71S – 100L	0.18 – 3.0

Frequency inverter operation / 87 Hz

Constant torque from 300 to 2 610 rpm CT 1:8:7

Design	Efficiency class	Size	Power rating P _N kW
DRE..J	– *	71S – 100M	0.55 – 5.5
DRP..J	– *	71S – 100L	0.55 – 5.5
DRU..J	– *	71S – 100L	0.25 – 4.0

Line operation / 50 Hz

Nominal speed: 1 500 rpm

Design	Efficiency class	Size	Power rating P _N kW
DRE..J	IE2	71S – 100M	0.37 – 4.0
DRP..J	IE3	71S – 100L	0.37 – 4.0
DRU..J	IE4	71S – 100L	0.18 – 3.0

* IE classification as per IEC 30034-30-1:2014 is only applicable to 50 Hz or 60 Hz

3.1 AC motors

DRM.. torque motors



DR.. series: DRM.. design

Features

The **DRM..** design is a 12-pole motor that can be operated continuously and thermally safely on a three-phase system even when the rotor is blocked. The designation **“torque motor”** is also maintained for DRM.. motors.

Every torque motor is available with three rated torques.

This allows for the requirements of the application to be easily met

- Many additional features of the AC motor modular system are available
- Can be combined with the 7-series of the modular gear unit system from SEW-EURODRIVE

Standstill torque, Rating 1 M_0 Nm

0.7 – 3.6 / 50 Hz
0.6 – 2.7 / 60 Hz

Cyclic duration factor Rating 1

S1, continuous duty

Standstill torque, Rating 2 M_0 Nm

2.6 – 17.3 / 50 Hz
2.1 – 12.2 / 60 Hz

Cyclic duration factor Rating 2

S3/15%, intermittent duty with a cyclic duration factor of 15%

Standstill torque, Rating 3 M_0 Nm

1.9 – 8.7 / 50 Hz
5.9 / 60 Hz

Cyclic duration factor Rating 3

S1, continuous duty with forced cooling fan

Sizes

71 – 132

Lengths

S, M, L

Frequency Hz

50, 60

DRK.. single-phase motors



NEW: DR.. series: DRK.. design

Features	The DRK.. design can be operated on the single-phase supply systems 1x 230 or 1x 220 V . The running capacitor installed in the terminal box allows for operation under many demanding ambient conditions. SEW-EURODRIVE also offers ET56 and ER63.		
Sizes	Power rating kW	Frequency Hz	Energy efficiency class ¹⁾
DRK71S4	0.18	50 or 60	IE1
DRK71M4	0.25		IE1
DRK80S4	0.37		IE1
DRK80M4	0.55		IE1
DRK90M4	0.75		IE1
DRK90L4	1.1		IE1
ET56	90 watts		
ER63	90 / 120 / 180 watts		Without capacitor

¹⁾ according to IEC 60034-30-1

3.1 AC motors

Excerpt of additional features

There are many additional features for motors and brakemotors of the DR.. series. They are combined in groups to provide a better overview.

Additional options	Description	
Mechanical mount-on components	Features that can be mounted to the DR.. motor using additional elements:	
	BE..	Single spring-loaded brake with size specification
	NEW: BF..	Double spring-loaded brake with size specification for industrial applications
	NEW: BT..	Double spring-loaded brake with size specification for stage applications
	HF, HR	Manual brake release, lockable or automatic disengaging
	/RS	Backstop instead of a brake
	/MSW	MOVI-SWITCH®, integrated switching and protection function
/MM..	MOVIMOT®, integrated frequency inverter	
Temperature sensor/detection	Designs that are offered with additional elements in the winding:	
	/TF	3 temperature sensors (PTC thermistor or PTC resistor) connected in series
	/TH	3 thermostats (bimetallic switches) in series
	/KY	1 temperature sensor KTY84-130
/PT	1 or 3 temperature sensor(s) PT100	
Ventilation	Designs in conjunction with cooling/ventilation functions on the DR.. motor:	
	/V	Forced cooling fan, IP66, AC voltage range or DC
	/Z	Additional flywheel mass (flywheel fan)
	/AL	Metal fan
	/U	Non-ventilated (only without fan)
	/OL	Non-ventilated (closed B-side)
/C	Canopy	

Bearings	Designs with bearing function, sizes 250, 280, 315:	
	/NS	Relubrication device
	/ERF	Reinforced bearings for high overhung loads (only with NS)
	/NIB	Insulated bearing (B-side)
Connection	Designs with connection alternatives:	
	/IS	Integrated plug connector
	/AS.. etc.	Installed plug connectors of various types
	/KCC	Terminal strip with cage clamps
Encoders	Designs with add-on encoders for various electrical interfaces:	
	/ES7.	Add-on encoder DR..71 – 132
	/EG7.	Add-on encoder DR..160 – 225
	/XV..	Mounting or mounting adapters of encoders that are not included in the SEW portfolio
Sensors	Designs with condition monitoring:	
	NEW: Option /DUE	Brake diagnostics through continuous functional and wear monitoring
Other	Other variants:	
	/DH	Condensation drain hole
	/2W	2nd shaft end on the motor/brakemotor
	/RI	Reinforced winding insulation for frequency inverter operation > AC 500 V
	/RI 2	Reinforced winding insulation with increased resistance against partial discharge

3.1 AC motors

Aseptic motors



DAS.. series

Features

for dry hygienic areas

DAS.. series aseptic gearmotors for drive solutions with smooth surfaces and without fans:

- IP66 degree of protection for motors (IP65 for brakemotors)
- Motor corrosion protection: KS internal coating
- Surface protection OS2 to OS4
- Motor protection thermistor in thermal class F, TH (thermo contact) optional
- IS plug connector

Type

Power in duty type kW

**S1 =
Continuous duty**

S3 = Intermittent duty

		S3 = Intermittent duty		
		60 %	40 %	25 %
DAS80K4	0.25	0.3	0.37	0.55
DAS80M4	0.37	0.45	0.55	0.75
DAS90S4	0.55	0.75	0.9	1.1
DAS90L4	0.75	0.98	1.1	1.5
DAS100M4	1.1	1.35	1.7	2.2
DAS100L4	1.5	1.85	2.3	3.0

ASEPTIC^{plus}® drive package**for hygienic production areas**

DAS.. series aseptic motors with ASEPTIC^{plus}® drive package:

- IP69K degree of protection for motors (IP65 for brakemotors)
- OS4 surface protection
- Contour recesses filled with rubber
- Double oil seals (if possible) at the output made of FKM (fluorocarbon rubber)
- Stainless steel breather valve
- Pressure compensation membrane at motor terminal box
- Cable entry with screw plugs made of stainless steel
- Gear unit output shaft made of stainless steel as solid shaft, hollow shaft with key, or TorqLOC® for the following gear unit types: R17-97, F37-97, K37-97, S37-97 and W30
- All retaining parts on the output shaft, such as screws, keys, shrink disk, etc., are made of stainless steel

3.1 AC motors

Explosion-proof motors



EDR.. series

compliant with EC Directive 94/9/EC (ATEX) and IECEx



Features

- EDRE.. motors meet the efficiency class IE2 according to IEC 60034-30-1 making them suitable for use worldwide
- Compliant with the efficiency classes according to MEPS requirements that are required in many countries
- The gearmotors/brakemotors meet the requirements of EU Directive 94/9/EC according to IECEx
- Available as gearmotor/motor in accordance with IECEx to EPL Gb and Db as well as Gc and Dc
- Available as gearmotor/motor in ATEX in categories 2G, 2GD and 3GD, 3D for zones 1 / 21 and 2 / 22
- Also available as brakemotor in category 3
- SEW-EURODRIVE has been audited and certified to 94/9/EC
- EDRS.. and EDRE.. motors of SEW-EURODRIVE were audited and certified by the PTB in compliance with IECEx "Certified Equipment Scheme" with ExTr, QAR and CoC; the certificates are available at <http://iecex.iec.ch>
- Operation on a frequency inverter, also in field weakening range operation, for categories 2 and 3 and/or EPL .b and .c
- Approvals for the motor were performed according to the latest European standards applicable to explosion protection:
General requirements IEC/EN 60079-0, gas IEC/EN 60079-7, IEC/EN 60079-15 and dust IEC/EN 60079-31
- Compliance with the internationally applicable Equipment Protection Level EPL
- EDR.. motors comply with the most important standards and meet IEC motor standard 60034
- The ATEX gear units comply with EN 13463-1, 5, and 8
- Same compact and power-oriented characteristics as the standard drives

Design ATEX	IECEx	Ex protection	Zone	Type 4-pole / size	IE class	Power range kW
/3D and /3GD	/3Gc and /3GDc	II3G, EPL Gc, T3, "nA"	2	DR63*	–	0.12 – 0.25
		II3D, EPL Dc, IIIB, IIIC T120 °C / T140 °C, "tc"	22	EDRS 71 – 80 EDRE 80 – 225 EDRE 250 – 315**	IE1 IE2 IE2	0.25 – 0.55 0.75 – 45 55 – 200
/2G and /2GD	/2Gb and /2GDb	II2G, EPL Gb, T3, "e"	1	EDRS 71 – 80	IE1	0.25 – 0.55
		II2D, EPL Db, IIIC T120 °C "tb"	21	EDRE 80 – 225	IE2	0.75 – 37
/2G and /2GD	/2Gb and /2GDb	II2G, EPL Gb, T4, "e"	1	EDRS 71 – 80	IE1	0.25 – 0.55
		II2D, EPL Db, IIIC T120 °C "tb"	21	EDRE 80	IE2	0.75

* Only acc. to ATEX

** In preparation

3.1 AC motors

Explosion-proof motors



EDR.. series according to HazLoc-NA®



Features

- EDRE.. motors not only meet the requirements of efficiency class IE2 according to IEC 60034-30-1 but also comply with EISA 2007 and CSA C390-10 for the North American market and thus meet the requirements of many countries that accept these standards.
- The motors are certified according to the Class Division System and thus meet the requirements of the explosion protection regulation on the North American market and the basic standards CSA 22.2 and NEC 500
- Available as gearmotor/motor, /CID2 type, for division 2 class I for gas groups A, B, C and D
- Available as gearmotor/motor, /CIID2 type, division 2 class II for dust groups F and G
- Available as gearmotor/motor, /CICIID2 type, for division 2 class I for gas groups A, B, C and D and Class II for dust groups F and G
- Also available as brakemotor with latch function
- SEW-EURODRIVE is certified to UL and CSA
- Operation on frequency inverter, also in field weakening range operation, possible in both classes
- Same compact and performance-oriented characteristics as the standard drives
- Motors also possible with ATEX gear units (EU directive 94/4/EC) on request

Division 2	Type 4-pole	IE class	Power range kW
Class I Group A, B, C, and D T3 with operation on frequency inverter T3C with operation on supply system T3B/C brakemotor on supply system	EDRS 71 – 80 EDRE 80 – 225	IE1 High (IE2)	0.18 – 0.55 0.75 – 45
Class II Groups F and G			

Explosion-proof AC asynchronous motors in combination with frequency inverters



Features

Overview of the advantages of this combination over AC asynchronous motors in protection type "d" (EN 60079-1; flameproof enclosure):

- High efficiency
- Lighter weight
- Shortest possible delivery times, high availability
- Certified for operation with SEW frequency inverters
- Suitable for pump and fan drives
- Delivery from a single source, from a manufacturer that offers both components itself
- Higher speeds

Strict adherence to guidelines is particularly important in areas with potentially explosive gas/air and dust/air mixtures. Thanks to many years of experience and competency in this area, SEW-EURODRIVE ensures that the relevant guidelines are observed. Furthermore, the company's expertise is continually being expanded to include new and further developments.

Certifications

- The 4-pole motors from SEW-EURODRIVE are also suited for operation on frequency inverters according to ATEX, IECEx, and HazLoc-NA®
- Category 2 and EPL b and c are certified by prototype testing
- Motors are certified to HazLoc-NA® by CSA
- In category 3 and division 2, brakemotors are also available
- The suitability for operation on inverters is confirmed on the nameplate
- A second nameplate provides all the information required for operation

Zone	Motor type	Protection type	MOVITRAC® B	MOVIDRIVE® B	MOVIMOT®
1	EDR../2GD	"e" (EN 60079-7, increased safety)	✓*	✓	–
2	EDR../3GD	"na" (EN 60079-15, non-sparking)	✓*	✓*	–
21	EDR../2GD	"tb" (EN 60079-31, dust explosion protection)	✓*	✓	–
22	EDR../3GD	"tc" (EN 60079-31, dust explosion protection)	✓*	✓*	✓*
	EDR../3D				

* also in field weakening range operation

3.1 AC motors

Explosion-proof motors in combination with frequency inverters



Features

The extensive product range of SEW-EURODRIVE inverters is available for designing electronically controlled drives:

- **MOVITRAC® MC07B:** Compact and economical standard inverter for the power range 0.25 – 75 kW. Three-phase line connection for AC 380 – 500 V.
- **MOVIDRIVE® MDX60/61B:** High-performance application inverter for dynamic drives in the 0.55 – 315 kW power range. Great diversity of applications due to extensive expansion options with technology and communication options. 3-phase line connection for AC 380 – 500 V.
- **MOVIMOT®** is the successful product in decentralized drive technology. It is the ingeniously simple combination of a gearmotor and a digital frequency inverter. MOVIMOT® in category 3D form a synthesis of EDR.. motors and integrated frequency inverters. These designs are designed specifically for use in areas with potentially explosive dust-air mixtures (zone 22) and are available in the power range of 0.25 kW to 3 kW, with or without brake, for connection voltages of 400 to 500 V.

Project planning	Project planning is the basic requirement for safe operation of explosion-proof motors. EDRS.. and EDRE.. motors meet the defined requirements for use in potentially explosive atmospheres of the Directive 94/9/EC (ATEX 95), IECEx and HazLoc-NA® Div. 2. A device for direct temperature monitoring in combination with the defined parameters of the frequency inverter offers the best possible protection against excessive heating caused by an overload.		
Technical data	EDR.. motors 230 / 400 V		
	Connection	Star	Delta
	P_{line} kW	M_{FI} Nm	M_{FI} Nm
Category 2G / 2D / EPL b / Div. 2	0.25 – 37	1.7 – 240	1.7 – 240
Category 3G / 3D / EPL c / Div. 2			
Category 3D with MOVIMOT®	0.25 – 3.0	1.7 – 20,5	1.2 – 9.9

For frequency inverter operation, there is no reduced load value in relation to the nominal line torque to ensure thermally safe operation as is often usual.

3.2 Servomotors

Synchronous servomotors



CMP.. series (high dynamics)

Features

- Highest dynamic Features due to low-inertia rotor design and high overload capacity of the motors
- Performance-optimized and extremely compact design thanks to the latest winding and magnet technology
- Standstill torques from 0.5 to 95 Nm
- Optional CMPZ.. motor design with additional rotor inertia for all applications with high load moments of inertia
- Direct motor mounting to gear units from our modular gear unit system



- Europe: CE marking
- USA: UR marking
- Canada: CSA label
- EAC: Eurasian conformity



- CMP../CMPZ.. motors are available in explosion-proof design, in compliance with the 94/9/EC directive (ATEX), for sizes 40S to 100L

Type	Rated speed rpm	M_0 Nm	M_{pK} Nm	J_{mot} kgcm ²	
				CMP..	CMPZ..
CMP40S	3 000 / 4 500 / 6 000	0.5	1.9	0.10	–
CMP40M	3 000 / 4 500 / 6 000	0.8	3.8	0.15	–
CMP50S	3 000 / 4 500 / 6 000	1.3	5.2	0.42	–
CMP50M	3 000 / 4 500 / 6 000	2.4	10.3	0.67	–
CMP50L	3 000 / 4 500 / 6 000	3.3	15.4	0.92	–
CMP63S	3 000 / 4 500 / 6 000	2.9	11.1	1.15	–
CMP63M	3 000 / 4 500 / 6 000	5.3	21.4	1.92	–
CMP63L	3 000 / 4 500 / 6 000	7.1	30.4	2.69	–

Type	Rated speed rpm	M ₀ Nm	M _{pK} Nm	J _{mot} kgcm ²	
				CMP..	CMPZ..
CMP71S / CMPZ71S	2 000 / 3 000 / 4 500 / 6 000	6.4	19.2	3.1	9.32
CMP71M / CMPZ71M	2 000 / 3 000 / 4 500 / 6 000	9.4	30.8	4.1	10.37
CMP71L / CMPZ71L	2 000 / 3 000 / 4 500 / 6 000	13.1	46.9	6.1	12.47
CMP80S / CMPZ80S	2 000 / 3 000 / 4 500 / 6 000	13.4	42.1	8.8	27.18
CMP80M / CMPZ80M	2 000 / 3 000 / 4 500 / 6 000	18.7	62.6	11.9	30.3
CMP80L / CMPZ80L	2 000 / 3 000 / 4 500 / 6 000	27.5	107	18.1	36.51
CMP100S / CMPZ100S	2 000 / 3 000 / 4 500	25.5	68.3	19.59	79.76
CMP100M / CMPZ100M	2 000 / 3 000 / 4 500	31	108	26.49	86.66
CMP100L / CMPZ100L	2 000 / 3 000 / 4 500	47	178.8	40.24	100.41
NEW: CMP112S	2 000 / 3 000 / 4 500	30	88	74	–
NEW: CMP112M	2 000 / 3 000 / 4 500	45	136	103	–
NEW: CMP112L	2 000 / 3 000 / 4 500	69	225	163	–
NEW: CMP112H	2 000 / 3 000 / 4 500	83	270	193	–
NEW: CMP112E	2 000 / 3 000 / 4 500	95	320	222	–

safetyDRIVE

Functional safety

Optional: Integrated functional safety for CMP.. motors

	FS safety-rated encoder	Up to PL d according to EN ISO 13849-1	AK0H(FS), AK1H(FS)
	FS safety-rated brake, safety functions – SBA (Safe Brake Actuation) – Safe braking – SBH (Safe Brake Hold) – Safe Torque Off	Up to PL c according to EN ISO 13849-1	BY(FS)

3.2 Servomotors

Synchronous servomotors



CM.. series (high inertia)

Features

- Standstill torques from 5 to 68 Nm
- Compact design with high power density due to optimized magnetic circuit layout
- High overload rating and reduced losses
- Electronic nameplate for fast and simple startup
- Optional: scalable HIPERFACE® encoder and high-performance working brake



- Europe: CE marking
- USA: UR marking
- Canada: CSA label
- EAC: Eurasian conformity

Type	Rated speed rpm	M ₀ Nm	M _{pk} Nm	Inertia kgcm ²	
				J _{mot} Nm	J _{bmot} Nm
CM71S	2 000 / 3 000 / 4 500 / 6 000	5	16.5	4.99	6.72
CM71M		6.5	21.5	6.4	8.13
CM71L		9.5	31.4	9.21	10.94
CM90S		11	39.6	18.2	22
CM90M		14.5	52.2	23.4	27.2
CM90L		21	75.6	33.7	37.5
CM112S	2 000 / 3 000 / 4 500	23.5	82.3	68.9	84.2
CM112M		31	108.5	88.9	104.2
CM112L		45	157.5	128.8	144.1
CM112H		68	238	188.7	204

3.2 Servomotors

Asynchronous servomotors



DRL.. series

Features

- Torques from 5 Nm to 290 Nm
- High rated torques make this series perfectly suitable for high dynamic loads with Features of an asynchronous servomotor
- Loads up to 3.5 times the nominal motor torque
- Safe and precise positioning in combination with MOVIAXIS® multi-axis servo inverters or MOVIDRIVE® application inverters

Rated torque Nm	Speed class rpm	Inertia kgcm ²
2.7 – 290	1 200	5.13 – 4 360
2.7 – 280	1 700	5.13 – 4 360
2.6 – 265	2 100	5.13 – 4 360
2.5 – 220	3 000	5.13 – 4 360

Dynamics packages

Dynamics package 1	190% – 220% M_{dyn} / M_N ; normal pinion shaft end for direct gear unit mounting
Dynamics package 2	300% – 350% M_{dyn} / M_N ; reinforced pinion shaft end for direct gear unit mounting

3.2 Servomotors

Explosion-proof servomotors



CMP40 – 100 series



Compliant with directive 94/9/EC (ATEX), equipment group II, equipment category 3

- Category II 3GD, suitable for use in zones 2 / 22
- Category II 3D, suitable for use in zone 22
- In category 3D also available with brake and Hiperface® encoder (with electronic nameplate)

Protection types

Dust atmosphere: Protection type “t” indicates dust explosion protection due to housing according to EN 60079-0 and -31

Gas atmosphere: Protection type “na” indicates

- Protection due to non-sparking according to EN 60079-0 and -15
- Design measures and requirements regarding dimensioning like for protection type “e”, but only fault-free operation is considered

Dust atmosphere: Degree of protection IP65

This means:

- Dust-tight housings according to EN 60079-31
- No dust can enter the housing due to the motor housing design
- Continuous monitoring of the surface temperature to exclude this as ignition source



- Europe: CE marking
- EAC: Eurasian conformity

Explosion-proof CMP. servomotors / compliant with EC Directive 94/9/EC (ATEX)

Category	Ex marking	Product characteristics	Options	Speed class
II3D	II3D Ex tc IIIC T150 °C X** Dc	<ul style="list-style-type: none"> – ATEX motor characteristic curves (thermal + dynamic) – Overload factor 3x standstill current I_0 	<ul style="list-style-type: none"> Brake Hiperface® Resolver 	<ul style="list-style-type: none"> 2 000 3 000 4 500
II3GD	II3G Ex nA IIC T3 X** Gc II3D Ex tc IIIC T150 °C X** Dc	<ul style="list-style-type: none"> – Grounding screw – IP65 – ATEX operating instructions – No forced cooling fan 	<ul style="list-style-type: none"> Resolver 	

** In conjunction with a matching temperature model in the inverter

3.2 Servomotors

Cables and connection options



CMP.. servomotor cable connections

Motor type	Power connector	Cable routing	Drive electronics
CMP40 – 63	Motor: SM1	Fixed installation or cable carrier installation	MOVIDRIVE® application inverter MOVIAXIS® multi-axis servo inverter
	Brakemotor: SB1		
CMP71 – 100	Motor: SM1, SMB	Fixed installation or cable carrier installation	MOVIDRIVE® application inverter MOVIAXIS® multi-axis servo inverter
	Brakemotor: SB1, SBB		
CMP112	Motor: SM1, SMB, SMC	Fixed installation or cable carrier installation	MOVIDRIVE® application inverter MOVIAXIS® multi-axis servo inverter
	Brakemotor: SB1, SBB, SBC		

Motor type	Encoder connector	Cable routing	Drive electronics
CMP40 – 112	RH1M resolver	Fixed installation or cable carrier installation	MOVIDRIVE® application inverter MOVIAXIS® multi-axis servo inverter
CMP40 – 63	HIPERFACE® AK0H, EK0H, AS1H, ES1H	Fixed installation or cable carrier installation	MOVIDRIVE® application inverter MOVIAXIS® multi-axis servo inverter
CMP71 – 112	HIPERFACE® AK0H, EK1H, AK1H	Fixed installation or cable carrier installation	MOVIDRIVE® application inverter MOVIAXIS® multi-axis servo inverter

DR.. series AC motor cable connections: Direct connection

Motor type	Encoder type	Encoder connection	Inverter connection
DR71 – DR132	EI7C, EI76, EI72, EI71	Conductor end sleeves	Conductor end sleeves MOVIDRIVE® B application inverter
		M12 plug connector	
	ES7S, ES7R, AS7W, AS7Y	Conductor end sleeves	D-sub plug connectors MOVIDRIVE® application inverter
		Connection cover	
DR160 – DR225	EG7S, EG7R, AG7W, AG7Y	Conductor end sleeves	
		Connection cover	
DR315	EH7S	M23 plug connectors	
	AH7Y	Conductor end sleeves	

DR.. series AC motor cable connections: Connection via intermediate sockets

Motor type	Encoder type	Encoder connection	Adapter plug
DR71 – DR132	ES7S, ES7R, AS7W	Conductor end sleeves	M23 plug connector (female connector)
		Connection cover	
DR160 – DR225	EG7S, EG7R, AG7W	Conductor end sleeves	
		Connection cover	

Intermediate socket

M23 plug connector (male connector)	Extension	M23 plug connector (female connector)
-------------------------------------	-----------	--

Intermediate socket

M23 plug connector (male connector)	Extension	D-sub plug connectors MOVIDRIVE® application inverter
-------------------------------------	-----------	--

3.3 Linear motion

Synchronous linear servomotors



SL2 series

Features	<ul style="list-style-type: none"> – Suitable application areas: highly dynamic, flexible processing machines; material handling; pick and place applications – No mechanical transmission elements and wear parts are required as linear motion and force are generated directly – Optimized force-density ratio due to modern winding technology and laminated iron core – Almost maintenance-free – High control quality, dynamics and precision – Available in three designs (SL2 basic, SL2 advanced system, SL2 power system) – Secondaries are available in various lengths and can easily be lined up 	
Product versions	Rated power range N	Rated speed classes m/s
SL2 Basic	125 – 6 000	1 / 3 / 6
SL2 Advance System	280 – 3 600	
SL2 Power System	400 – 5 500	

Options for linear servomotors

SL2 Advance System and SL2 Power System	<ul style="list-style-type: none"> – The cables of the motor end have matching plug connectors – EMC-compliant connector housing design – Plug connectors seal the plug on the cable end with a lamellar seal and ensure strain relief in accordance with EN 61884 – Various accessories for inverter-specific prefabrication
--	---

Standard CMS.. electric cylinders / with grease lubrication



CMS50/71 series (with grease lubrication)

Features	<ul style="list-style-type: none"> – Equipped with permanent magnet rotors – Precise, powerful and fast – Combined with drive electronics from SEW-EURODRIVE, this series makes for energy-efficient drive solutions that ensure a high level of process reliability and that can be easily integrated into existing automation systems
-----------------	--

Electrical data

Type	CMS71L		
Max. torque Nm	31.4	22.1 ¹⁾	24.4 ¹⁾
Standstill torque Nm	9.5		

Mechanical data

Rated speed n_N	2 000 rpm 3 000 rpm 4 500 rpm			
Spindle type	KGT ²⁾ 32x10	KGT ²⁾ 32x6	PGT ³⁾ 24x5	
Max. continuous feed force ³⁾ N	3 600	6 700	7 200	
Peak feed force N	17 000	20 000	15 000 20 000 ⁵⁾	20 000
Stroke lengths mm	200	200	350	200
Max. speed mm/s	500	300	200	250

¹⁾ Maximum permitted torque

²⁾ Ball screw

³⁾ Planetary roller screw

⁴⁾ Depending on average travel speed

⁵⁾ In case of tensile loads

3.3 Linear motion

Standard CMS.. electric cylinders / with oil bath lubrication



CMSB50/63/71 series (with oil bath lubrication)

Features

- Patented maintenance-free oil bath lubrication (lifetime lubrication)
- Very high thermal power density
- Especially low-noise operation
- Very short working strokes (< 1 mm)
- Combined with drive electronics from SEW-EURODRIVE, this series makes for energy-efficient drive solutions that ensure a high level of process reliability and that can be easily integrated into existing automation systems

Electrical data

Type	NEW: CMSB50S	NEW: CMSB50M	NEW: CMSB50L
Max. torque Nm	5.2	7 ¹⁾	7 ¹⁾
Standstill torque Nm	1.3	2.4	3.3

Mechanical data

Rated speed n_N	3 000 rpm 4 500 rpm 6 000 rpm		
Spindle type	KGT ²⁾ 20x5	KGT ²⁾ 20x5	KGT ²⁾ 20x5
Max. continuous feed force ⁴⁾ N	1 200	2 200	2 200
Peak feed force N	5 300	8 000	8 000
Stroke lengths mm	70 / 100 / 150 / 200 / 300 / 400 / 600		
Max. speed mm/s	375	375	375

Electrical data				
Type	CMSB63S		CMSB63M	
Max. torque Nm	11.1		11.1 ¹⁾	
Standstill torque Nm	2.9		5.3	
Mechanical data				
Rated speed n_N	3 000 rpm 4 500 rpm 6 000 rpm			
Spindle type	KGT ²⁾ 25x6	PGT ³⁾ 20x5	KGT ²⁾ 25x6	PGT ³⁾ 20x5
Max. continuous feed force ⁴⁾ N	2 400	2 800	4 100	5 200
Peak feed force N	10 000		10 000	
Stroke lengths mm	60 / 100 / 160 / 180 / 200 / 400 / 600	100 / 200	60 / 100 / 160 / 180 / 200 / 400 / 600	100 / 200
Max. speed mm/s	450	375	450	375

Electrical data			
Type	CMSB71S	CMSB71M	CMSB71L
Max. torque Nm	19.2	25 ⁴⁾	25 ⁴⁾
Standstill torque Nm	6.4	9.4	13.1
Mechanical data			
Rated speed n_N	2 000 rpm 3 000 rpm 4 500 rpm 6 000 rpm		
Spindle type	KGT ²⁾ 32x6	KGT ²⁾ 32x6	KGT ²⁾ 32x6
Max. continuous feed force ⁴⁾ N	5 000	7 500	10 000
Peak feed force N	18 000	24 000	24 000
Stroke lengths mm	100 / 160 / 200 / 400 / 600 / 800 / 1 000 / 1 200		
Max. speed mm/s	450	450	450

¹⁾ Maximum permitted torque²⁾ Ball screw³⁾ Planetary roller screw⁴⁾ Depending on average travel speed

3.3 Linear motion

Modular CMSM.. electric cylinders



CMSMB50 – 71 series / ACH or ACA (axially serial)

Features

- Separately available modular unit (linear gear unit) with the proven oil bath lubrication of the CMSB.. standard electric cylinder series
- Can be combined with the standard servomotors from SEW-EURODRIVE (CMP50/63/71) using ACH/ACA adapters

Technical data

Type	NEW: CMSMB50 / ACH or ACA	CMSMB63 / ACH or ACA	CMSMB71 / ACH or ACA
Max. permitted input torque Nm	7	11.1	25
Max. permitted input speed rpm	4 500	4 500	4 500
Peak feed force N	8 000	10 000	24 000
Stroke lengths mm	70 / 100 / 150 / 200 / 300 / 400 / 600	60 / 100 / 160 / 180 / 200 / 400 / 600	100 / 160 / 200 / 400 / 600 / 800 / 1 000 / 1 200
Spindle type	KGT ¹⁾ 20x5	KGT ¹⁾ 25x6	KGT ¹⁾ 32x6

¹⁾ Ball screw



CMSMB50 – 71 series / AP (axially parallel)

Features

- Compact design
- Patented maintenance-free oil bath lubrication (lifetime lubrication)
- Very high thermal power density
- Very low-noise operation
- Optional water cooling
- Use of CMP50/63/71 standard servomotors

Electrical data

Type	CMSMB50/AP and		
	NEW: CMP50S	NEW: CMP50M	NEW: CMP50L
Max. torque Nm	5.2	7 ¹⁾	7 ¹⁾
Standstill torque Nm	1.3	2.4	3.3

Mechanical data

Rated speed n_n	3 000 rpm 4 500 rpm 6 000 rpm		
Spindle type	KGT ²⁾ 20x5		
Max. continuous feed force N	1 200	2 200	2 200
Peak feed force N	5 300	8 000	8 000
Stroke lengths mm	70 / 100 / 150 / 200 / 300 / 400 / 600		
Max. speed mm/s	375	375	375

¹⁾ Max. permitted torque

²⁾ Ball screw

3.3 Linear motion

Modular CMSM.. electric cylinders



CMSMB50 – 71 series / AP (axially parallel)

Electrical data

Type	CMSMB63/AP and		
	CMP63S	CMP63M	CMP63L
Max. torque Nm	11.1	11.1 ¹⁾	11.1 ¹⁾
Standstill torque Nm	2.9	5.3	7.1

Mechanical data

Rated speed n_N	3 000 rpm 4 500 rpm 6 000 rpm		
Spindle type	KGT ²⁾ 25x6		
Max. continuous feed force N	2 400	3 600	4 800
Peak feed force N	10 000	10 000	10 000
Stroke lengths mm	60 / 100 / 160 / 180 / 200 / 400 / 600		
Max. speed mm/s	450	450	450

¹⁾ Max. permitted torque

²⁾ Ball screw

Electrical data

Type	CMSMB70/AP and		
	CMP71S	CMP71M	CMP71L
Max. torque Nm	19.2	25 ¹⁾	25 ¹⁾
Standstill torque Nm	6.4	9.4	13.1

Mechanical data

Rated speed n_N	2 000 rpm 3 000 rpm 4 500 rpm 6 000 rpm		
Spindle type	KGT ²⁾ 32x6		
Max. continuous feed force N	5 000	7 500	10 000
Peak feed force N	18 000	24 000	24 000
Stroke lengths mm	100 / 160 / 200 / 400 / 600 / 800 / 1 000 / 1 200		
Max. speed mm/s	450	450	450

¹⁾ Max. permitted torque²⁾ Ball screw

3.4 Accessories and options

Brakes and brake control

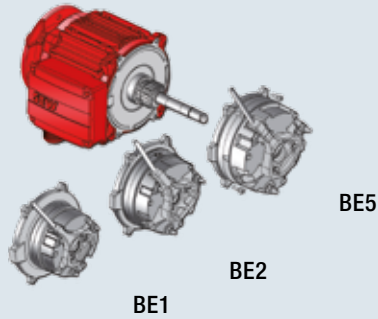

The brake of your choice –
Extract from the brake combination options

Motor type	Brake type	W _{insp} 10°J	Braking torque steps Nm							
		
DR..90	BE1	120	5	7	10					
	BE2	165		7	10	14	20			
	BE5	260				14	20	28	40	55
DR..100	BE2	165		7	10	14	20			
	BE5	260				14	20	28	40	55
...							

Brake combination options

The DR.. motor can be combined with the ideal BE brake to match its requirements for the braking torque or braking work. Moreover, brakes mounted on motors larger than size 90 have an additional special feature. The brake itself is mounted on a friction plate, which only has to be attached to the end shield. This means that the unit can be removed and changed – for a bigger or smaller brake – without opening the motor.

safetyDRIVE
Functional safety



- FS safety-rated BE.. brake (FS02) in horizontal operation up to PL d and in vertical operation up to PL c in accordance with EN ISO 13849-1 with indication of the size
- **NEW:** Static and dynamic brake diagnostics for MOVI-PLC® in addition to the brake
- Safety functions of our brakes
 - SBC (safe brake control)
 - SBA (safe brake actuation)
 - SBH (safe brake hold)



NEW: BF../BT.. double brake for DR.. motors

The brake of your choice – Brake combination options

Motor type	Brake type	W _{insp} 10°J	Braking torque steps Nm									
			2x20	2x28	2x40	2x55	2x80	2x110				
DR.112/132	BF11	2x285										
	BT11	2x190										
DR.160	BF20	2x445			2x40	2x55	2x80	2x110	2x150	2x200		
	BT20	2x300										
DR.180	BF30	2x670					2x75	2x100	2x150	2x200	2x300	
	BT30	2x450										

Brake combination options

The DR.. motor can be combined with the ideal BF../BT.. brake to match its requirements for the braking torque or braking work. Brakes mounted on motors of the sizes 112 to 180 are very compact.

The double disk brake can be used in dusty environments with or without “functional safety”. An extremely low-nose BT.. design with functional safety is available to meet the requirements of stage applications.

NEW: The BF../BT.. double brake can be equipped with the contactless DUE.. function and wear monitoring.

It displays

- the current switching state or if the wear limit has been reached and
- continuously sends the current air gap.

safetyDRIVE Functional safety





- **NEW:** Safety-rated BF.. double brake (FS02)
Up to PL “e” according to EN ISO 13849-1
- **NEW:** Safety-rated BT.. brake (FS02)
Up to PL “e” according to EN ISO 13849-1, and according to DIN 56950-1
- **NEW:** Static and dynamic brake diagnostics for SEW controllers (MOVI-PLC® / CCU)
as a supplement to the brake

* available as of 3rd quarter of 2015

3.4 Accessories and options

Built-in encoders



Advantage		The available built-in encoders for the DR.. motors series that can be installed on the B-side between endshield and fan wheel are unique. With this solution the user does not have to provide for additional space as it is the case with add-on speed sensors*. MOVITRAC® standard inverter in combination with the “simple positioning” application module can replace applications that, up to now, have been realized with creep/rapid speed switch-over with initiator evaluation.
Built-in encoders		EI7C, EI76, EI72, EI71
Signal type		HTL (push-pull)
Supply voltage		DC 9 – 30 V
Periods per revolution	A, B	EI7C: 24 EI76: 6 EI72: 2 EI71: 1
Motor sizes of the DR.. series		– DRE../DRS../DRP../DRU...: 71 – 132 – DRN...: 80 – 132S – DRU...: 71 – 100
Connection		– Terminal strip in terminal box – 8-pin M12 plug connector – 4-pin M12 plug connector
safetyDRIVE Functional safety 		FS safety-rated built-in encoder up to PL d according to EN ISO 13849-1: EI7C FS..
*Add-on speed sensor		Types: – ES7S, EG7S, EH7S, EV7S: with Sin/Cos interface – ES7R, EG7R, EH7R: with TTL (RS-422) interface – AS7W, AG7Y: RS-485 interface (multi-turn) – AS7Y, AG7Y, AH7Y: SSI interface (multi-turn) – ES7A, EG7A: Mounting adapter for speed sensor from the SEW-EURODRIVE portfolio – XV.A: Mounting adapter for non-SEW speed sensors – XV...: Mounted non-SEW speed sensors
safetyDRIVE Functional safety 		FS safety-rated encoders up to PL d according to EN ISO 13849-1 Types: – ES7S, EG7S: with Sin/Cos interface – AS7W, AG7Y: RS-485 interface (multi-turn) – AS7Y, AG7Y, AH7Y: SSI interface (multi-turn)



**Corrosion protection (KS) and surface protection (OS)
for all standard motors and gear units**

Features	To protect motors and gear units that are subject to severe environmental influences, SEW-EURODRIVE offers possibilities to increase the resistance of highly stressed surfaces.
KS corrosion protection	Measures to increase the resistance to corrosion: <ul style="list-style-type: none"> - All retaining screws that are loosened during inspection or maintenance work are made of stainless steel - Nameplates are made of stainless steel and various motor parts are coated with a finishing varnish - The flange contact surfaces and shaft ends are treated with a temporary rust preventive - In addition, clamping straps are used for brakemotors
OS surface protection	In addition to the standard surface protection, motors and gear units are optionally available with surface protection OS1, OS2, OS3 or OS4. This makes the gearmotors well equipped for operation under various ambient conditions.

Measures for interior treatment and standard parts

Special interior surface treatment

Brakes with pressure plate made of non-corrosive material

Rustproof nameplates

Non-corrosive retaining parts

RS bearing for IP56

Special interior surface treatment

Special interior surface treatment

Rustproof breather valves





NOCO® fluid, the contact corrosion inhibitor



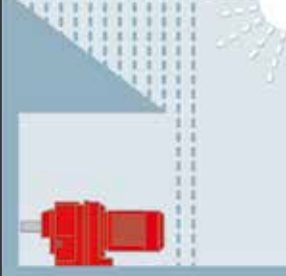

Output shaft made of stainless steel

Optional coating at drive shaft end (in the area of the radial oil seal seat)

3.4 Accessories and options

Surface protection (OS)

Surface protection		Ambient conditions/sample applications
Standard		<p>For machines and systems within buildings and interior rooms with neutral atmospheres.</p> <ul style="list-style-type: none"> – C1 (negligible)* <p>Sample applications:</p> <ul style="list-style-type: none"> – Machines and systems in the automobile industry – Conveyor systems in logistics areas – Conveyor belts at airports
OS1		<p>For environments prone to condensation and atmospheres with low humidity or contamination. E.g. outdoor applications under a roof or protection device.</p> <ul style="list-style-type: none"> – C2 (low)* <p>Sample applications:</p> <ul style="list-style-type: none"> – Systems in saw mills – Hall gates – Agitators and mixers
OS2		<p>For environments with high humidity or moderate atmospheric contamination. E.g. applications outdoors subject to direct weathering.</p> <ul style="list-style-type: none"> – C3 (moderate)* <p>Sample applications:</p> <ul style="list-style-type: none"> – Applications in amusement parks – Funiculars and chair-lifts – Applications in gravel plants – Systems in nuclear power plants
OS3		<p>For environments with high humidity and occasionally severe atmospheric and chemical contamination. Occasional acidic or caustic wet cleaning. Also for applications in coastal areas with moderate salt load.</p> <ul style="list-style-type: none"> – C4 (high) * <p>Sample applications:</p> <ul style="list-style-type: none"> – Sewage treatment plants – Port cranes – Mining applications
OS4		<p>For environments with permanent humidity and severe atmospheric or chemical contamination. Regular acidic and caustic wet cleaning, also with chemical cleaning agents.</p> <ul style="list-style-type: none"> – C5-I (severe) * <p>Sample applications:</p> <ul style="list-style-type: none"> – Drives in malting plants – Wet areas in the beverage industry – Conveyor belts in the food industry

Surface protection		Ambient conditions/sample applications
Aseptic motors of the DAS.. series Either OS2–OS4		Suitable for dry or wet hygienic areas with average atmospheric contamination. Also suitable for particularly dusty environments. <ul style="list-style-type: none"> – C3 (moderate)* Sample applications: <ul style="list-style-type: none"> – Applications in clean rooms – Machines in the cosmetic and pharmaceutical industry – Systems for processing cereals and flour (without Ex protection) – Conveyor belts in cement plants
Aseptic motors of the DAS.. series with drive package Aseptic^{plus}® OS4		For hygienic areas in the food and beverage industry with permanent humidity, regular acidic or caustic wet cleaning with chemical agents and pressure cleaning. <ul style="list-style-type: none"> – C5-I (severe) * Sample applications: <ul style="list-style-type: none"> – Hygienic and aseptic conveyors in the beverage industry – Systems in cheese dairies and meat processing plants – „Splash zones“ in the food industry
High Protection Coating HP200		For hygienic areas in the food and beverage industry with regular acidic and caustic wet cleaning. Anti-stick Features support the cleaning process even in inaccessible areas. Sample applications: <ul style="list-style-type: none"> – Hygienic and aseptic conveyors in the Beverage industry – Systems in cheese dairies and meat processing industries – „Splash zones“ in the food industry
Stainless steel gearmotor		For hygienic areas in the food and beverage industry with permanent humidity and extreme acidic and caustic wet cleaning using chemical cleaning agents. Sample applications: <ul style="list-style-type: none"> – Hygienic and aseptic applications of all types – Systems in cheese dairies and meat processing industries – Food processing machines for the North American market

* In accordance with the corrosivity categories of DIN EN ISO 12944-2

04

INDUSTRIAL GEAR UNITS

4.1 Helical gear units /

bevel-helical gear units

Helical gear units / bevel-helical gear units, X series	146
Bevel-helical gear units, X series – conveyor drives	147
Bevel-helical gear units, X series – bucket elevator drives	148
NEW: Helical gear units / bevel-helical gear units, X series – agitator drives	149
Helical gear units / bevel-helical gear units, MC series	150
Helical gear units, MACC series	151
Helical gear units / bevel-helical gear units, M1 series	152
Helical gear units / bevel-helical gear units ML series	153

4.2 Planetary gear units

Planetary gear units, P series	154
NEW: Helical / bevel-helical planetary gear units, P-X series	155
Planetary gear units, XP series	156

4.3 Explosion-proof industrial gear units

157

4.4 **NEW:** Segmented girth gears

158



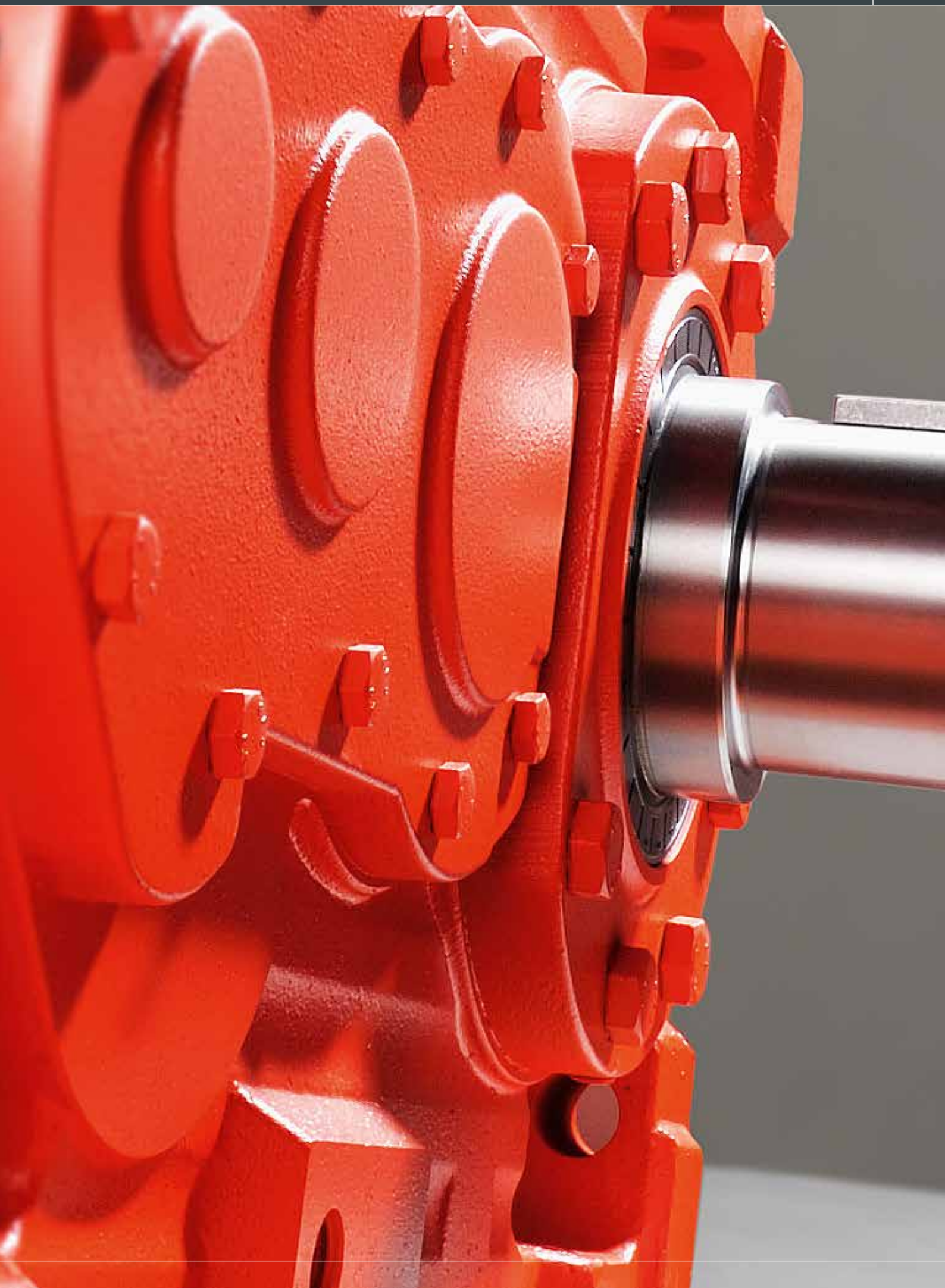

4.1 Helical gear units / bevel-helical gear units

X series



Features	<ul style="list-style-type: none"> – Independent industrial gear unit platform with 23 sizes – Single-piece or split gear unit housings – Invertible gear unit housings – Universal mounting positions – Distinctive modular concept technology – Diverse predefined optional equipment and options for customer-specific adaptations – Areas of application: conveyor systems in various industries, mixers, and agitators, etc. 		
Advantages	<ul style="list-style-type: none"> – Reduced costs and weight due to high power density and finely stepped sizes – Extremely robust gear unit housing – Effective cooling systems – Flexible mounting options 		
Gear unit design	Stages	Gear ratio i	Nominal torque M_{N2} kNm
Helical gear units X.F.	2, 3 and 4 stages	6.3 – 450	6.8 – 475
Bevel-helical gear units X.K..	2, 3 and 4 stages	6.3 – 450	6.8 – 475 ¹⁾
Bevel-helical gear units X.T..	3 and 4 stages	12.5 – 450	6.8 – 175

¹⁾ 2-stage: $M_{N2} = 6.8 - 175$ kNm

A project-specific solution can be offered on request for the torque range from 475 to 1 200 kNm.
Please contact your local sales representative.

X series – belt conveyors

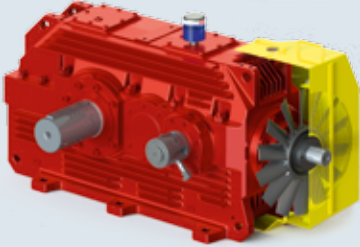

Features	<ul style="list-style-type: none"> – Gear unit consists of the tried and tested components of the X series – Three-stage helical-bevel gear unit with special horizontal housing for improved heat dissipation – Increased cooling capacity due to efficient fan concept – Comprehensive range of accessories of the X series – Versatile shaft concepts – Taconite sealing system – Pressure lubrication and splash lubrication available – Also available in ATEX design – Standard backstop; optional torque-limited backstop – Available as a complete package, e.g. including brake, swing bases, rigid flange coupling, condition monitoring, etc. 		
Advantages	<ul style="list-style-type: none"> – Efficient cooling concept eliminates the need for external cooling units and a larger gear unit – Reliability especially in harsh environments – Simplified maintenance - two-piece housings 		
Gear unit design	Stages	Gear ratio <i>i</i>	Nominal torque M_{N2} kNm
Bevel-helical gear units X3K.B..	3-stage	12.5 – 90	58 – 475

4.1 Helical gear units / bevel-helical gear units

X series



X series – bucket elevator drives

Features

- 19 sizes
- Based on the X series with the successful SEW gearmotor as auxiliary drive
- Auxiliary drive adapter with overrunning clutch and incremental encoder
- Mounted backstop
- Areas of application: conveyor systems in the most various industries, in particular for bucket elevators in bulk material handling applications

Advantages

- All drive components are perfectly matched
- Reliability thanks to speed monitoring
- High availability thanks to modular concept
- Extensive optional equipment available on request

Gear unit design	Stages	Gear ratio <i>i</i>	Nominal torque M_{N2} kNm
Bevel-helical gear units X3K.B..	3-stage	28 – 80	6.8 – 270



NEW: X series – agitator drive*

Features

- 8 sizes
- Gear unit consists of the tried and tested components of the X series
- Application-specific rolling bearing concept for absorbing external forces and bending moments
- Three-stage helical gear unit design with special vertical housing for optimized heat dissipation
- Modular helical and bevel-helical gear unit design based on the universal housing of the X series can be used universally
- Foot-mounted and flange-mounted designs available
- Efficient sealing system including drywell seal
- Available with pressure or oil bath lubrication
- Also available in ATEX design
- Areas of application: Agitators, surface aerators, flotation cell, etc.

Advantages

- Gear unit housing is perfectly designed for agitator applications
- High availability due to modular and widely used X series
- Consumption of high loads directly on the gear shaft possible. The systematical use of additional rolling bearings in the application is not necessary

Gear unit design	Stages	Gear ratio i	Nominal torque M_{N2} kNm
Helical gear units with vertical housing	3-stage	20 – 100	22 – 90
Helical and bevel-helical gear units with universal housing	2 to 4 stages	6.3 – 450	22 – 90

* Available as of 3rd quarter of 2015

4.1 Helical gear units / bevel-helical gear units

MC series



Features

- Independent industrial gear unit series with 8 sizes
- Modular concept
- Special solutions can be realized
- Block housing without parting line
- Universal mounting positions
- All commercially available connection elements are possible at the input and output sides
- EBD concept with predefined bearing types depending on the requirement profile and application
- Optional variable flange geometries and “drywell” version
- Areas of application: conveyor systems in various industries, mixers, agitators, shredders and crushers, etc.

Advantages

- High power density
- Sturdy unit due to block housing

Gear unit design	Stages	Gear ratio i	Nominal torque M_{N2} kNm
Helical gear units MC.P.	2 and 3 stages	7.1 – 112	6 – 65
Bevel-helical gear units MC.R..	2 and 3 stages	7.1 – 112	6 – 65

MACC series



Features

- 5 sizes
- Improved extended housing for motor
- Drywell
- Shaft end pump for pressure lubrication
- Cooling fan
- Backstop, internal design
- Areas of application:
This gear unit series is tailored for use in air cooled condensers
- Optional:
 - On request: special gear ratio
 - Explosion protection

Advantages

- Optimized thermal rating
- High degree of housing stiffness
- High permitted axial load on output shafts
- Reliable surface treatment for use under aggressive ambient conditions

Gear unit design MACC series	H	W	L	Gear ratio <i>i</i>	Nominal torque M_{N2} kNm
05	484	480	897	9 – 25	21
06	516	530	992		28
07	540	570	1 055		37
08	585.5	716	1 187		51
09	606	730	1 267		66

4.1 Helical gear units / bevel-helical gear units

M1 series



Features	<ul style="list-style-type: none"> – 11 sizes – Foot-mounted helical gear units – Oil heater available – Sealing system also for harsh conditions – Cooling with fan or cooling coil – Rigid housing design for thermal efficiency and stability – Optional accessories available – Areas of application: Pump drives or rollers and refiners in the paper industry 		
Advantages	<ul style="list-style-type: none"> – Very easy maintenance due to horizontally split housing design – Optimized thermal power – Gear unit for smaller gear ratios for increased energy efficiency and cost-effectiveness in many applications 		
Gear unit design	Stages	Gear ratio i	Nominal torque M_{N2} kNm
Helical gear units M1..	1-stage	1.25 – 7.1	4.5 – 168

ML series



Features	<ul style="list-style-type: none"> – 5 sizes – Housing in welded construction with parting line – Horizontal mounting position – Areas of application: Hoists in crane construction, mill drives in raw material processing, special machines and stand-alone machines, etc. 		
Advantages	<ul style="list-style-type: none"> – Flexible thanks to the welded construction of the housing – Service friendly due to the parting line 		
Gear unit design	Stages	Gear ratio <i>i</i>	Nominal torque M_{N2} kNm
Helical gear units ML.P..	2, 3 and 4 stages	5.6 – 315	180 – 680
Bevel-helical gear units ML.R..	3, 4 and 5 stages	14 – 1 250	180 – 680

4.2 Planetary gear units

P series



Features

- 11 sizes
- Transmission of high torques for powerful movement of large quantities
NEW: with torque increase
- Compact design for limited installation space
- High permitted radial loads
- Primary gear units in helical and bevel-helical version can be combined with the planetary gear unit
- Areas of application: Construction materials industry, cement industry, process engineering, steel industry, materials handling, and waste water industry

Advantages

- Perfectly matched units (gear unit and motor)
- Large range of options due to the SEW-EURODRIVE modular concept
- Short, compact design as there is no need for couplings and adapter flanges
- Standardized units for ideal cost/benefit ratio and short delivery times
- High gear ratios possible

Gear unit design	Stages	Gear ratio i	Nominal torque M_{N2} kNm
Helical planetary gear units (garmotors) P.RF.	4 and 5 stages	100 – 4 000	24 – 630 ¹⁾
Bevel-helical planetary gear units (garmotors) P.KF	5 stages	140 – 4 000	24 – 630 ¹⁾

¹⁾ Increased nominal torque for available sizes on request

P-X series



Features	<ul style="list-style-type: none"> - 7 sizes - High transmittable torque and very compact design - Variable in the gear reduction range - Weight-optimized drive - High permitted radial load at output - Invertible housing - High thermal rating - Shared oil chamber - Areas of application: Apron feeders, bucket-wheel reclaimers, boom drives, chip board plants 		
Advantages	<ul style="list-style-type: none"> - Sealing systems and lubrication variants are available to suit specific applications - Reduced space and weight due to the use of a motor scoop or adapter - Reduced costs as no replacement gear unit is needed (invertible housing) - Can be used at very low temperatures 		
Gear unit design	Stages	Gear ratio i	Nominal torque M_{N2} kNm
P-X: Helical / bevel-helical planetary gear units	4 stages	160 – 550 *	100 – 500 *

* For gear ratios outside this range, contact your local sales representative

4.2 Planetary gear units

XP series



Features	<ul style="list-style-type: none"> – 13 sizes – Transmission of high torque ratings – Suitable for high motor power – High power density – Wide gear ratio range – Variable cooling system – Different coupling variants – Various mounting positions – Can be combined with primary gear unit – Areas of application: Materials handling, raw material processing, food industry, sugar industry, paper industry, raw material extraction 		
Advantages	<ul style="list-style-type: none"> – Maximum flexibility makes for customized solutions – Gear ratio according to customer request – Wide range of equipment options 		
Gear unit design	Stages	Gear ratio i	Nominal torque M_{N2} kNm
Planetary gear units XP..	2 and 3 stages	50 – 3 000 *	600 – 5 200

* In combination with primary gear units from the modular system for standard gear units of SEW-EURODRIVE

We offer tailor-made project solutions on request.

4.3 Explosion-proof industrial gear units

Explosion-proof industrial gear units



Explosion protection according to ATEX

ATEX designs of industrial gear units:
(Group II, categories 2/3G and 2/3D,
zones 1, 21, 2 and 22)

- X series
- MC series
- P series

Gear units comply with directive 94/9/EC
(ATEX), equipment group II, category 2, II2GD
design

- For use on the European market
- Accepted in China
- Accepted in Russia in conjunction with EAC certificates (successor to GOST-R)

Certified protection types

- Protection type “c”: Protected by safe construction (design safety), EN13463-1 and -5
- Protection type “k”: Protected by liquid immersion, EN13463-1 and -8

4.4 Segmented girth gears

NEW: Segmented girth gears



Segmented girth gears

Features

- Girth gear pitch diameter up to about 16 m*
- Maximum width 600 mm
- Maximum power 4000 kW per pinion
- Maximum pitch line velocity 6 m/s
- Girth gear module 20, 25, 30, and 40 mm
- Calculated according to ISO standard 6336 (AGMA on request)

Advantages

Highly segmented girth gears, segments

1. Easy casting

The design of the feeders and the use of heat sinks guarantee a seamless casting quality even with critical segments

2. Convenient handling

- The handling of the individual segments and component groups is simplified both in the factory and at the construction site
- No need for special transportation arrangements: segmented girth gears can be transported in standard containers

3. Optimized quality assurance

- The minimized size brings also cost advantages when it comes to the scrapping of blanks
- Flawless blanks can be used without additional welding or oversizing

4. Precise pitch accuracy

- The segmented girth gears from SEW-EURODRIVE guarantee the initial pitch accuracy of ISO 8 (AGMA 9)
- Because of the high pitch accuracy, the vibrations of the girth gears are kept to a minimum

5. Easy replacement

If a segment is damaged, it can be exchanged without dismantling the whole ring

6. Reduced weight

- ADI** has an over-average contact fatigue strength due to its cold work hardening Features
- These Features combined with an appropriate girth gear size enable a compact and lighter design compared to the traditional solution
- The low weight is important for the handling and the assembly of the girth gear as well as the achievable circumferential velocity

7. Increased service life

With the correct dimensioning, load and lubrication, an ADI** girth gear is nearly wear-free

8. Shorter delivery time

The small segments allow for fast production and short delivery times

* Larger diameters are possible. Contact SEW-EURODRIVE.

** Made of tempered ductile iron

Project planning	Thanks to their remarkable material Features, girth gears made of ADI** can have less than half the weight of girth gears made of conventional materials that offer the same performance and safety. Project planning for girth gears by SEW-EURODRIVE is therefore an important requirement for creating customer benefits. The high degree of segmentation ensures that individual customer requirements can be met in an ideal way.
Applications	<p>Example: mill / application size examples</p> <ul style="list-style-type: none"> – Power rating: up to approx. 15 MW – Diameter: up to approx. 16 m – Assembly: flange – Speed of rotation: high (10 to 20 rpm) <p>Example: rotary kiln / application size examples</p> <ul style="list-style-type: none"> – Power rating: up to approx. 1 MW – Diameter: up to approx. 9 m – Assembly: leaf spring – Speed of rotation: low (1 to 2 rpm)
Possible scope of delivery	<ul style="list-style-type: none"> – Segmented girth gears – Drive pinion and, if required, pedestal bearing – Fastening parts for the girth gear: mounting springs or mounting flange – Main gear unit – Motors – Auxiliary drives – Lubrication system – Foundation and base frame – Couplings and covers – Condition monitoring – Installation as well as startup of the whole drive system

05

DECENTRALIZED DRIVES / MECHATRONICS

5.1 Gearmotors with inverter

MOVIMOT®	162
Field distributors and fieldbus interfaces	164

5.2 Energy-efficient mechatronic drives IE4

DRC.. electronic motors	166
Mechatronic MOVIGEAR® drive system	168
Installation topologies with	
- SNI controller	170
- SEW system bus controller	171
- Binary	172
- AS-Interface	173
- NEW: central: with control cabinet inverter	174

5.3 Gearmotors with motor starter

MOVI-SWITCH®	175
--------------	-----

5.4. **NEW:** Decentralized extra-low voltage servo drive

CMP.. ELVCD	176
-------------	-----







5.1 Gearmotors with MOVIMOT® inverter

Gearmotor with inverter



MOVIMOT®

Speed range rpm	Voltage V	Connection	Power kW	Torque Nm	Motor type
280 – 1 400 (1 700) 300 – 1 500	3 x 380 – 500	λ	0.37 – 4.0	2.52 – 27.3 2.35 – 25.5	DRS.., DRE.., DRN.. DRE..J, DRU..J
290 – 2 900 300 – 2 610	3 x 380 – 500	△	0.55 – 4.0 0.37 – 4.0	1.81 – 13.2 1.35 – 14.6	DRS.., DRE.., DRN.. DRE..J, DRU..J
280 – 1 700	3 x 200 – 240	λ λ	0.37 – 2.2	2.08 – 12.4	DRE.., DRS..
Features	<ul style="list-style-type: none"> – The product of success in decentralized drive technology: an ingenious combination of a gearmotor and an integrated digital frequency inverter – Available in all standard gearmotor variants and mounting positions, with or without brake – MOVIMOT® of the D series can be combined with our DR.. motor series with various efficiency levels as standard: <ul style="list-style-type: none"> - with DRU.. motors = IE4 Super Premium Efficiency - with DRN.. motors = IE3 Premium Efficiency - with DRE.. motors = IE2 High Efficiency <p>In combination with the DRE.., DRN.., and DRU.. motor series, MOVIMOT® complies with the highest efficiency class IES2 for drive systems according to EN 50598-2.</p>				
Degrees of protection	IP54, optionally IP55, IP65 or IP66				
Ambient temperature	–30 °C/–20 °C to +40 °C (depending on the motor design)				
Control via binary signals	Inputs for CW/stop, CCW/stop, setpoint changeover, potential-free signal relay, fixed setpoints, acceleration and deceleration ramps				
Control via fieldbus communication	<p>In combination with fieldbus interfaces with and without minicontroller PROFIBUS, INTERBUS, EthernetNet™ IP, DeviceNet™, AS-Interface, PROFINET IO and NEW SBUS^{PLUS}/EtherCAT® (see page 164)</p> <p>Startup modes: easy, expert, central via PLC</p>				

Use in stand-alone applications	In combination with the following options: <ul style="list-style-type: none"> – MLU..A: Local DC 24 V supply – MLG.1A: Local setpoint adjuster with DC 24 V supply – MBG11A: Setpoint adjuster for setting and displaying the setpoint frequency – MWA21A: Setpoint converter for interfacing analog setpoints (0 to 10 V, 0 – 20 mA, 4 – 20 mA) to RS-485 			
Use in decentralized installation	In combination with the field distributors: <ul style="list-style-type: none"> – MF.../Z.3. – MF.../Z.6. – MF.../.../Z.7. – MF.../.../Z.8. – And associated hybrid cables 			
Diagnostics	3-color LED to indicate operating and fault states via diagnostic interface, serial interface RS485 and MDG11A option or PC			
Approval	IEC or 			
safetyDRIVE Functional safety	You can also satisfy these additional requirements with an optional safety package: <ul style="list-style-type: none"> – Safety category 3 according to EN 954-1 – Performance level d in accordance with EN ISO 13849-1 – SIL 2 according to IEC 61 800-5-2 Safety function: Safe Torque Off (STO) up to PL d according to EN ISO 13849-1			
Features of MOVIMOT® in category 3D 	<ul style="list-style-type: none"> – Design: with EDR.. motors and an integrated frequency inverter – Specifically for use in potentially explosive dust/air mixtures – Power range from 0.25 to 3.0 kW, with and without brake for connection voltages of 400 to 500 V 			
Nominal speed rpm	Voltage V	Connection	Power kW	Torque Nm
1 400	3 x 400 – 500	λ	0.25 – 3.0	1.7 – 20.5
2 900	3 x 400 – 500	△	0.37 – 3.0	1.2 – 9.9

5.1 Gearmotors with inverter MOVIMOT®

Fieldbus interfaces, field distributors and cable systems



MF.. fieldbus interface

MFE52 fieldbus interface for PROFINET IO

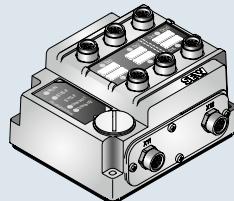

MQ.. fieldbus interface

Features

- Connection of MOVIMOT® and MOVI-SWITCH® drives to the standardized fieldbus systems PROFIBUS, INTERBUS, EtherNet/IP™, DeviceNet™, AS-Interface, PROFINET IO and **NEW** SBus^{PLUS}/EtherCAT®
- Fieldbus interfaces are based on a module terminal box with connecting terminals and a pluggable fieldbus module; these fieldbus interfaces can be mounted directly on the drive, in the field, or in the field distributor
- The adjustable-speed MOVIMOT® drive is connected to the bus using terminals; additional sensors, actuators or MOVI-SWITCH® gearmotors without control can be connected to the bus using terminals or M12 plugs
- Easy fault diagnostics via bus in the event of a malfunction by means of diagnostic interfaces and LED signals
- Reading sensor signals
- Controlling actuators via digital input and output terminals
- IP65 degree of protection
- Option package: Degree of protection IP66, stainless steel cable glands, pressure compensation fitting, M12 metal plug for fieldbus modules with M12 plug connectors

Additionally integrated controller with the following functions:

- Programmable via IPOS^{PLUS}®
- Simple positioning with EI76 incremental encoder
- Integrated I/O preprocessing and timing elements
- Protocol modification

Options for fieldbus interfaces

MF.. / MQ..

- The **MFG11A keypad** is plugged on any MFZ.. connection module instead of a fieldbus interface for manually controlling a MOVIMOT® drive
- **DBG60B keypad** for manually controlling MOVIMOT® drives; additionally, the process data words can be displayed in monitor mode; direct connection to the diagnostic interface of MOVIMOT® or the MF./MQ.. fieldbus interface

Hybrid cables

- Cables that combine energy transfer, control voltage, and communication in one cable sheath (SEW in-house development) ensure optimum EMC shielding and impedances
- The hybrid cable for connecting MOVIMOT® to field distributors combines the communication interface and supply and control voltage connections in one cable and is supplied as a pre-fabricated cable with plug connector
- MOVIMOT® drives with connected hybrid cable can be connected to the field distributor in a matter of seconds and are ready for operation
- Simple handling in case of service: The connector can be disconnected without any danger, the drive can be replaced and the new drive re-connected quickly
- Ideal for all systems with high demands on availability



NEW: MFE72A SBUS^{PLUS}/EtherCAT[®] fieldbus interface

Features

- Connection of MOVIMOT[®] drives to an SBUS^{PLUS}/EtherCAT[®] fieldbus system
- Compatible with all existing SEW field distributors
- Reading-in of sensor signals via M12 plug connectors
- Control of actuators via M12 plug connectors
- IO update cycle ≥ 1 ms
- Selectable number of process data (4PD/10PD)
- Degree of protection IP65

Seamless networking

- The MFE72A fieldbus interface enables simple and efficient communication between decentralized drives and SBUS^{PLUS}/EtherCAT[®] masters
- Added value due to flexible additional functions such as encoder evaluation and counting input for fast pulse trains

Integrated additional functions

- Integrated encoder evaluation for master-based simple positioning
- Compatible with built-in encoder EI7C from SEW
- Counting input for fast pulse trains, e.g. for product identification using a light barrier

5.2 Energy-saving mechatronic drives IE4

DRC.. electronic motors



Features / advantages

- Combination of a permanent-field synchronous motor with integrated drive electronics in a completely enclosed housing
- High gear unit flexibility thanks to variable combinations with modular gear unit system of SEW-EURODRIVE
- A completely new mechatronic drive system is generated together with a helical-bevel, helical or parallel-shaft helical gear unit
- The optimized system efficiency offers an energy saving potential of up to 50% and thus a reduction of the TCO due to innovative technology:
 - Permanent-field synchronous motor instead of asynchronous motor
 - Motor efficiency higher than efficiency class IE4 (Super Premium Efficiency) of IEC 60034
 - Electronics integrated into the motor for optimal functionality and minimal losses
 - Optimized electronic components and intelligent control modes
- Overload capacity of up to 250% for high breakaway and acceleration torques prevent oversizing in static operation and reduces the installed system power
- Universal application due to large control range of 1:2000
- Positioning capability on integrated feedback system
- High degree of protection
- Worldwide use due to the large input voltage and frequency range as well as the compliance with all worldwide energy efficiency regulations
- The systematic development of all components ensures high reliability and a long service life, resulting in a high system availability
- Monitoring functions and maintenance are supported
- Quick and simple installation
- Detailed diagnostic options
- Installation topology with SEW-EURODRIVE controller:
 - SNI: Only one cable for power supply and communication; Installation effort reduced by up to 60%
 - SBus: for applications with high performance demands
- Installation topology binary or AS-Interface for easy drive functions
- Integrated functional safety: Safe Torque Off (STO) up to PL e according to EN ISO 13849-1

safetyDRIVE
Functional safety

Application options	Perfectly suitable for many industries such as beverage and food, automotive and pharmaceutical industry but also airport logistics, intralogistics in general, or construction industry.
Application examples	<ul style="list-style-type: none"> – Inclining tracks and hoists – Belt, chain or roller conveyors – Pallet conveyors and palletizers – Rollover machines – Roller conveyors or ascending conveyors – Areas in front of a machine – Drives for positioning and synchronous operation
Torque and power classes	<ul style="list-style-type: none"> – DRC..1 with 2.6 Nm nominal torque (power rating 0.55 kW) – DRC..2 with 7.2 Nm nominal torque (power rating 1.5 kW) <p>In preparation:</p> <ul style="list-style-type: none"> – DRC..3 with 14.3 Nm nominal torque (power rating 3 kW) – DRC..4 with 19.1 Nm nominal torque (power rating 4 kW)
Gear unit flexibility	<ul style="list-style-type: none"> – Standard flanges for combination with 7-series gear units from SEW-EURODRIVE – Stand-alone motors with IEC flange
Application options DRC.. electronic motor with optional digital inputs and outputs 	<ul style="list-style-type: none"> – Reading and processing of digital and analog sensor signals decentralized and close to the drive via GIO12B and GIO13B application options – Fast response to changes of the sensor state due to decentralized processing and response – Reduced effort for cabling and installation <p>GIO12B application option</p> <ul style="list-style-type: none"> – 4 digital inputs – 2 digital outputs for actuator control <p>GIO13B application option</p> <ul style="list-style-type: none"> – 4 digital inputs (of which 2 can be used as primary frequency inputs) – 1 digital output – 1 analog input – 1 analog output

5.2 Energy-saving mechatronic drives IE4

MOVIGEAR®



Features / advantages

- Completely integrated, compact design: Motor, gear unit and electronics are combined in a single mechatronic drive system
- The optimized system efficiency offers an energy saving potential of up to 50% and thus a reduction of the TCO due to innovative technology:
 - Permanent-field synchronous motor instead of asynchronous motor
 - Motor efficiency higher than efficiency class IE4 (Super Premium Efficiency) of IEC 60034
 - Helical gearing for extremely compact design and highest efficiency
 - Electronics integrated into the motor for optimal functionality and minimal losses
 - Optimized electronic components and intelligent control modes
- Overload capacity of up to 350% for high breakaway and acceleration torques prevent oversizing in static operation and reduces the installed system power.
- High degree of protection
- Worldwide use due to the large input voltage and frequency range as well as the compliance with all worldwide energy efficiency regulations
- The systematic development of all components ensures high reliability and a long service life, resulting in a high system availability
- Monitoring functions and maintenance are supported
- Quick and simple installation
- Detailed diagnostic options
- Installation topology with SEW-EURODRIVE controller:
 - SNI: only one cable for power supply and communication; installation effort reduced by up to 60%
 - SBus: for applications with high performance demands
- Installation topology binary or AS-Interface for easy drive functions
- Integrated functional safety: Safe Torque Off (STO) up to PL e according to EN ISO 13849-1

safetyDRIVE
Functional safety



**University of Applied Sciences
of Kaiserslautern**
Department of Applied
Engineering Sciences

**Verified by an independent entity:
Energy saving potential of up to 50%**

“A comparison of the test results shows a significant efficiency advantage of MOVIGEAR® drives ... over the entire load range.”

Application options	Perfectly suitable for many industries such as beverage and food, automotive and pharmaceutical industry but also airport logistics, intralogistics in general, or construction industry.
Performance classes and designs 	MOVIGEAR® is available in two sizes, three performance classes and two mechanical variants: <p>MOVIGEAR® performance classes</p> <ul style="list-style-type: none"> – MGF.2 (Torque class: 200 Nm, up to 0.8 kW) – MGF.4 (torque class: 400 Nm, up to 1.6 kW) – MGF.4/XT (torque class: 400 Nm with extended continuous torque, up to 2.1 kW) <p>MOVIGEAR® variants</p> <ul style="list-style-type: none"> – MOVIGEAR® with hollow shaft and key – MOVIGEAR® with TorqLOC® hollow shaft mounting system
Variant for special ambient conditions 	<ul style="list-style-type: none"> – Meets all of the requirements for use in hygienic areas – HP200 surface treatment with optimal anti-adhering Features <ul style="list-style-type: none"> - ECOLAB®-tested chemical and mechanical resistance - FDA approval - Minimal cleaning effort – Degree of protection IP66 – Perfectly suited for nearly all applications in clean room environments as it complies with all requirements of clean room drives up to air cleanliness class 2 according to ISO 14644-1 (confirmed by Fraunhofer Institute) – Pressure compensation fitting – Stainless steel fitting – Internal pressure compensation
Application options MOVIGEAR® with optional digital inputs and outputs 	<ul style="list-style-type: none"> – Reading and processing of digital and analog sensor signals decentralized and close to the drive via GIO12B and GIO13B application options – Fast response to sensor signals due to decentralized processing in the drive – Reduced effort for cabling and installation <p>GIO12B application option</p> <ul style="list-style-type: none"> – 4 digital inputs – 2 digital outputs for actuator control <p>GIO13B application option</p> <ul style="list-style-type: none"> – 4 digital inputs (of which 2 can be used as primary frequency inputs) – 1 digital output – 1 analog input – 1 analog output

5.2 Energy-saving mechatronic drives IE4

Installation topology with SNI controller

Single Line Network Installation

Features	<ul style="list-style-type: none"> - SNI uses the cabling infrastructure of the energy supply as the basis for the transmission of communication signals - Easy installation as only supply cables need to be connected - Drive networks can be implemented with up to 100 m extensions and 10 slaves - Routing of bus cables or 24 V supply to drives not necessary - No risk of hidden faults in the bus wiring - Reduced startup time - Shorter project runtimes/reduction of project costs
Application options	<ul style="list-style-type: none"> - Installation topology for easy installing of MOVIGEAR® / DRC.. drive systems for conveyor systems that require variable speeds or local positioning - SNI components in combination with MOVIGEAR® actuators and DRC.. in SNI design as extension to process more distributed sensors without additional infrastructure
Application examples	<ul style="list-style-type: none"> - Belt conveyors - Pallet conveyors - Roller and wheel conveyors - Screw conveyors - Container and packaging unit transports - Chain and drag-chain conveyors
NEW: SNI components	<ul style="list-style-type: none"> - CSW maintenance switch <ul style="list-style-type: none"> - Possibility to disconnect single SNI actuators individually - Communication to all other actuators is maintained - SNI I/O system CIO: <ul style="list-style-type: none"> - Networking of process-relevant, not directly assigned sensors via the SNI infrastructure - Intelligent preprocessing of sensors and integration into the CCU structure

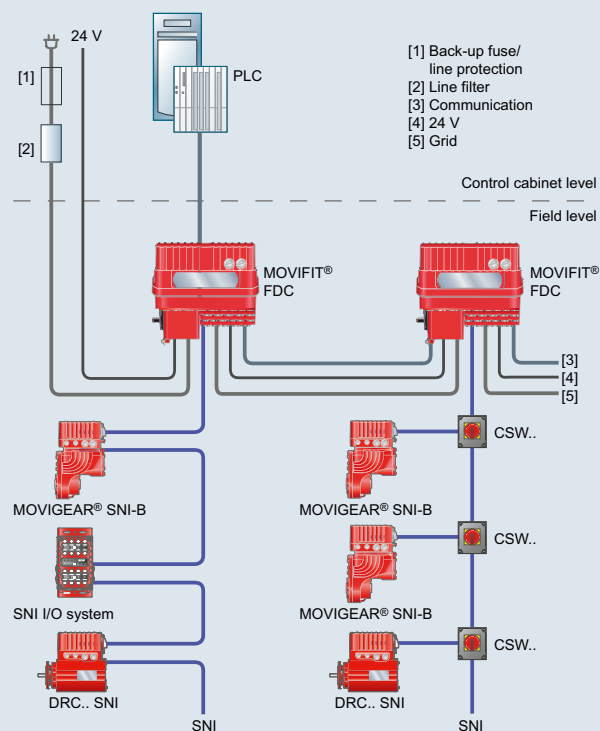

Installation topology with SEW system bus controller

SEW system bus High performance and fast bus communication via CAN

Features	<ul style="list-style-type: none"> - Line wiring - Fast communication for short response times - Hybrid cable for minimum installation effort - System bus controller for control cabinet or fieldbus installation with integrated PLC
Application options	<ul style="list-style-type: none"> - Installation topology for easy installation of MOVIGEAR® / DRC.. drive systems for conveyor systems that are operated dynamically with variable speeds - For forming intelligent function groups - As group drive for phase-synchronous operation
Application examples	<ul style="list-style-type: none"> - Pallet conveyors - Machine-integrated conveyor belts - Feeding conveyors - Synchronized feeder conveyors - Reversing drives

05

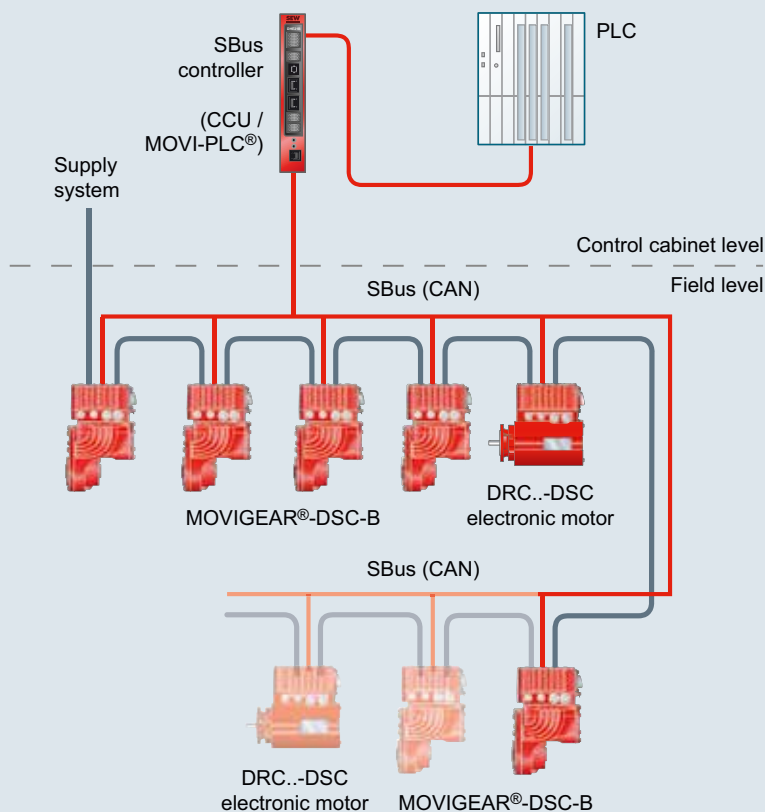

5.2 Energy-saving mechatronic drives IE4

Binary installation topology

Binary stand-alone operation

Features	<ul style="list-style-type: none"> - Fixed speeds/ramps can be set using potentiometers or parameterized with software - Central control using discrete signals from a PLC - Can be started up without a PC - 4 digital inputs - 1 relay signal output
Application options	<ul style="list-style-type: none"> - Simple stand-alone und single applications - For applications that require soft startup behavior - Applications with two fixed speeds - For applications with high breakaway torques - As a replacement for line-powered drives
Application examples	<ul style="list-style-type: none"> - Simple conveyors - Rotary tables - Adjustment drives - Agitators and mixers - Crushers and shredders - Presses

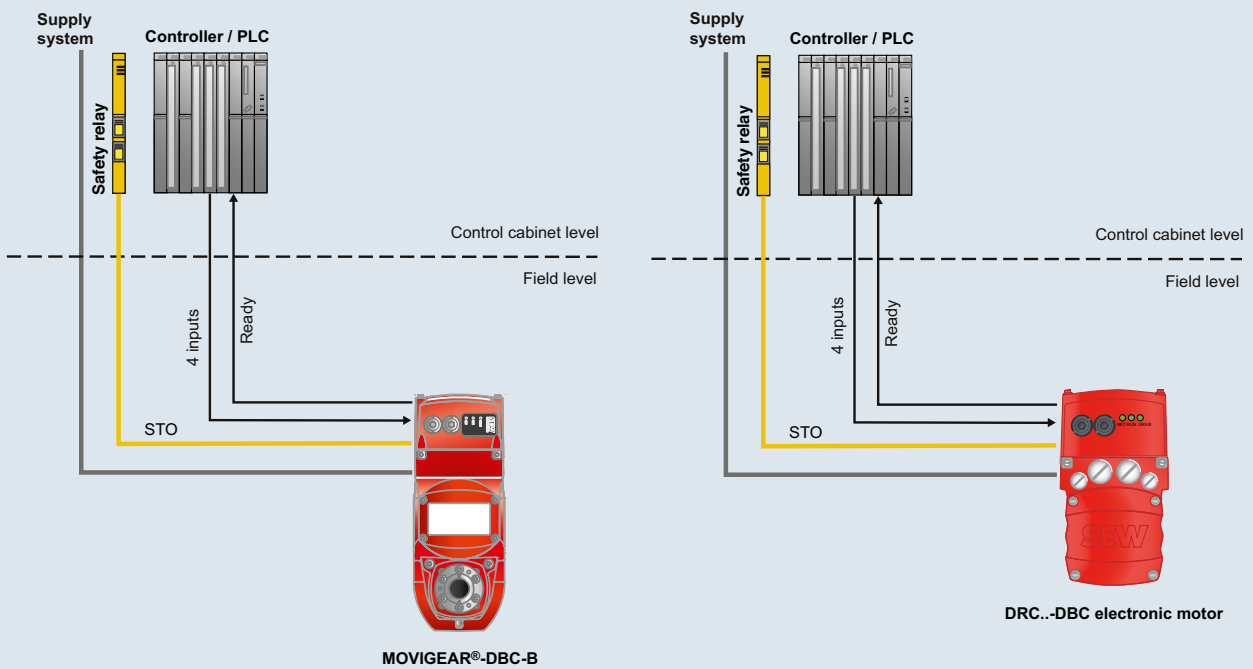

Installation topology with AS-Interface

AS-Interface Simple and economical fieldbus connection

Features	<ul style="list-style-type: none"> - Parameterizable fixed speeds and ramps - 2 designs <ul style="list-style-type: none"> - Binary slave (GLK30) - Double slave (GLK31) - 2 sensor inputs connected directly via the AS-Interface nodes - Safe Torque Off (STO) according to EN 13849 PL e - 4 digital inputs for local mode - Expanded startup using the diagnostics interface
Application options	<ul style="list-style-type: none"> - Simple fieldbus connection - For applications that require soft startup behavior - Signal feedback of connected sensors - For applications that require a lot of space - Individual parameter access in connection with GLK31
Application examples	<ul style="list-style-type: none"> - Accumulating roller conveyors - Roller and wheel conveyors - Pallet conveyors - Rotary tables

05

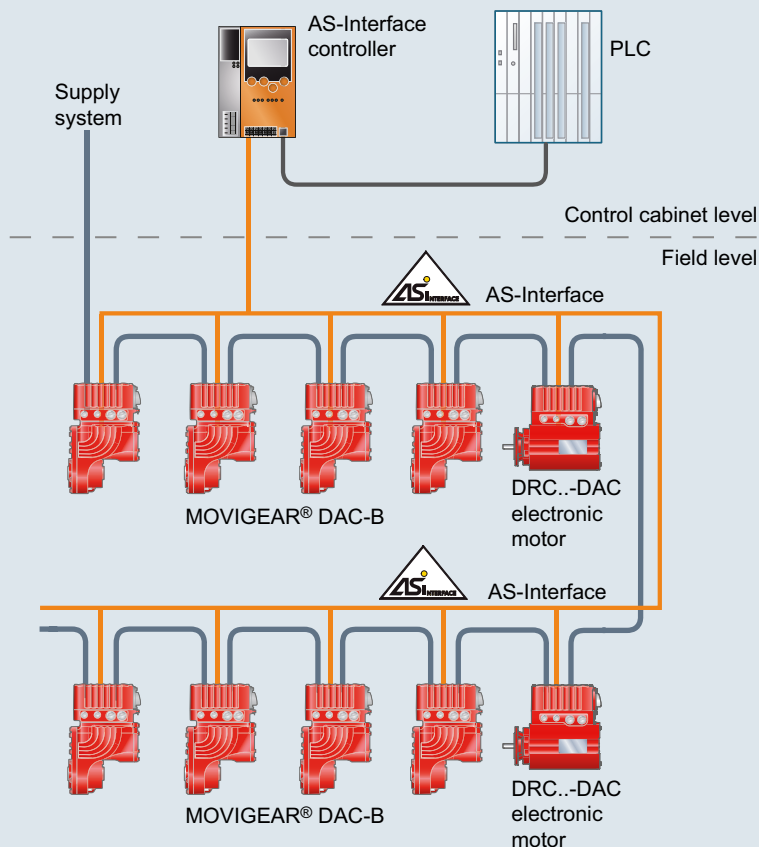

5.2 Energy-saving mechatronic drives IE4

NEW: Central installation topology with control cabinet inverter

Features	<ul style="list-style-type: none"> – MGF..-DSM gearmotor unit as alternative for centralized control cabinet installations – The frequency inverter installed in the control cabinet is connected to the MGF..-DSM drive unit – In combination with MOVITRAC® LTP-B control cabinet inverters easy startup with only two parameters – Parameterizable fixed speeds and ramps – With application controller CCU identical interfaces/functions for speed control to those for decentralized solutions
Application options	<ul style="list-style-type: none"> – Flexibility when planning new systems, particularly for exchange and retrofit projects – As drive for applications with high breakaway and starting torques – Conveyor systems with variable speeds – As drive for applications that require soft and/or defined startup behavior
Application examples	<ul style="list-style-type: none"> – Transport of bottles, packaging units and containers – Belt conveyors – Screw conveyors

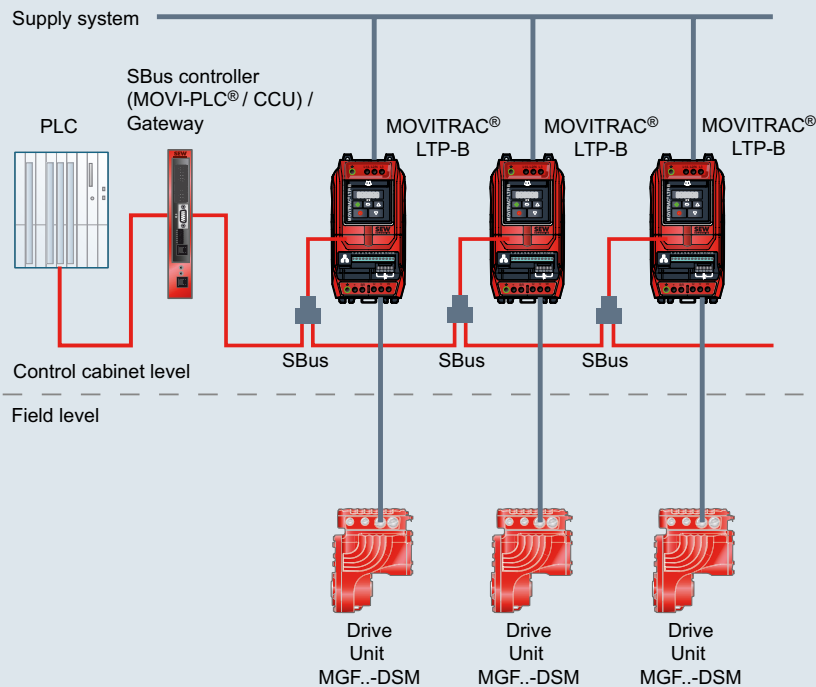

5.3 Gearmotors with motor starter MOVI-SWITCH®

Gearmotor with motor starter



MOVI-SWITCH®

Features	<ul style="list-style-type: none"> – Switching and protection function integrated in the motor terminal box – Compact and robust gearmotor – No further cabling required – No additional control cabinet space is needed – Available in all AC motor and brakemotor combinations of the DR.. series with the matching gear units 		
Number of poles	Power range kW		
	MSW-1E	MSW-1EM	MSW-2S
4	0.37 – 3.0	0.09 – 0.25	0.37 – 3.0
2	0.37 – 3.0	0.12 – 0.37	0.37 – 3.0
6	0.25 – 1.5	–	0.25 – 1.5
Switching function	On/off, one direction of rotation		On/off, two directions of rotation
Switching element	Contactless star bridge switch		Switching element with contact
Direction of rotation	CW or CCW, depending on the phase sequence		CW and CCW, regardless of the phase sequence
Control	<ul style="list-style-type: none"> – Binary control signals RUN / OK – Connection using 1x M12 plug connector 		<ul style="list-style-type: none"> – Binary control signals CW / CCW / OK – Connection using 2x M12 plug connectors – Alternatively with integrated AS-Interface
	–	Alternatively with integrated AS-Interface	
Brake management	With brake rectifier as standard BGW	With brake rectifier as standard BG	<ul style="list-style-type: none"> – Integrated brake control – Optional external control with BGM brake rectifier
Protection function	Thermal motor protection with integrated evaluation		<ul style="list-style-type: none"> – Thermal motor protection with integrated evaluation – Supply system monitoring (Power and phase failure)
Degree of protection	IP54, optionally IP55, IP65 or IP66		
Ambient temperature	–25 °C to + 40 °C (to + 60 °C)		

05

➔ **Accessories and options:**
Field distributor and fieldbus interfaces: page 164

5.4 **NEW:** Decentralized extra-low voltage servo drive



CMP.. ELVCD

Features

- Compact decentralized installation
- High continuous and peak power
- Robust design with convection cooling
- Easy installing with DC 48 V extra-low voltage
- All connections pluggable
- High degree of protection IP65
- UL-approved¹⁾
- Integrated braking resistor
- Optional encoder systems and brake
- Flexible gear unit combination
- Integrated engineering with the integration of the MOVI-PLC[®] controller
- Coordinated multi-axis movements can be realized with our MOVI-PLC[®] motion and logic controller

¹⁾ In preparation

Installation topology with the CMP.. ELVCD decentralized extra-low voltage drive

- CMP.. ELVCD is supplied with DC 24 V (control) and DC 48 V (power supply).
- The drive is controlled via SBus with a controller from SEW-EURODRIVE, which functions as central head station.
- The controller is responsible for the coordination and the higher-level motion control for all connected drives.
- Depending on the power demands and the synchronicity of the drives, several drives can be connected and supplied via one phase winding.
- The used controllers offer conventional interfaces for higher-level automation levels. The automation system can also be operated independently as a module.

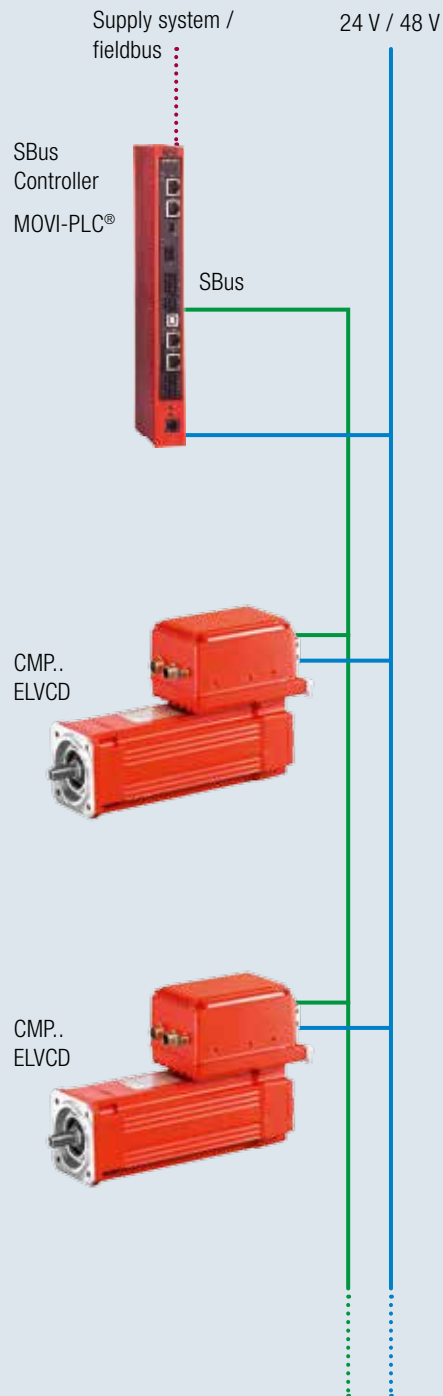

06 INVERTER TECHNOLOGY

6.1 Control cabinet installation

MOVITRAC® LTE-B basic inverters	180
MOVITRAC® LTP-B standard inverters	181
MOVITRAC® B standard inverters	182
MOVIDRIVE® B application inverters	185
MOVIAXIS® multi-axis servo inverters	188
MOVIDRIVE® MDR regenerative power supply units	192
effiDRIVE®: Energy efficiency in the control cabinet and in servo applications	198

6.2 Wall mounting

MOVI4R-U® basic inverters	202
MOVITRAC® LTE-B basic inverters in IP66	204
MOVITRAC® LTP-B standard inverters in IP55	204

6.3 Decentralized installation: Motor starters

Basic motor starters MOVIFIT® basic	206
MOVI-SWITCH® motor starter	207
MOVIFIT® SC motor starter	208

6.4 Decentralized installation: Inverters

Basic inverters MOVIFIT® basic	210
MOVIMOT® standard inverters	211
MOVIFIT® MC distributors – classic: for MOVIMOT®	212
MOVIFIT® FC inverters	214
MOVIPRO® standard and application inverters	216
NEW: MOVIAXIS® MMD60B decentralized servo inverters	217

6.5 Accessories and options

Software	
MOVITOOLS® engineering software	218
MOVIVISION® plant software	219





SEW

6.1 Control cabinet installation

MOVITRAC® LTE-B basic inverters



MOVITRAC® LTE-B

Features	<ul style="list-style-type: none"> – Standard design for installation in the control cabinet in degree of protection IP20 /NEMA 1 – Optionally available in degree of protection IP66 / NEMA 4x field housing for wall mounting
Line connection	Power range kW
115 V / 1-phase	0.37 – 1.1
230 V / 1-phase	0.37 – 4.0
230 V / 3-phase	1.5 – 4.0
400 V / 3-phase	0.75 – 11.0
Features	<ul style="list-style-type: none"> – Integrated control plate for simple handling – Pre-configured to match the respective motor – Integrated EMC filter – Energy saving function – Extra quiet pulsed voltage supply up to 16 kHz – Integrated help card – Integrated SEW system bus (SBus) – Programmable motor protection functions – 41 configurable parameters – Approved in accordance with UL508, C22.2 no. 14
Options	
DFx../UOH...	Can be connected to all common fieldbus types using the SEW gateway
LT BP-B	Parameter module for data transmission
USB11A	Interface adapter
LT BG-C	Additional control plate for external operation
BW...	Braking resistors
NF LT...	Line filters
ND LT...	Line chokes
HD LT...	Output chokes
PC engineering package	Connection to an PC engineering system

MOVITRAC® LTP-B standard inverters



MOVITRAC® LTP-B



Features

Flexible, simple and safe:

- Standard design in degree of protection IP55 / NEMA 12k housing for wall mounting
- Optionally also available in degree of protection IP20/NEMA for control cabinet installation
- Control of synchronous and asynchronous motors without encoder (V/f, VFC, VFC torque)

Line connection

Power range kW

230 V / 1-phase

0.75 – 2.2

230 V / 3-phase

0.75 – 5.5

400 V / 3-phase

0.75 – 11.0

575 V / 3-phase

0.75 – 15.0

→ More information on MOVITRAC® LTP-B IP55 / NEMA 12k housing: Page 204

6.1 Control cabinet installation

MOVITRAC® B standard inverters



MOVITRAC® B



Features	<ul style="list-style-type: none"> – Compact frequency inverter for space-saving installation for applications in the power range from 0.25 to 75 kW – Its straightforward operation saves time during startup – Versatile unit concept – Wide range of communication and expansion options
Line connection	Power range kW
230 V / 1-phase	0.25 – 2.2
230 V / 3-phase	0.25 – 30
400 / 500 V / 3-phase	0.25 – 75
Standard design	Equipped with integrated IPOS ¹⁾ positioning and sequence control ¹⁾ as standard. The standard basic equipment of the units can be expanded through various options.
Technology version with application modules	<p>In addition to having the characteristics of the standard design, the units in the technology version provide access to application modules, meaning control programs to realize technical drive tasks: Simple positioning</p> <p>Advantages of the application module:</p> <ul style="list-style-type: none"> – High functionality and user-friendly operator interface – You only have to enter the parameters needed for the application – Guided parameterization instead of complicated programming – All motion functions are controlled directly in MOVITRAC® B
Energy efficiency	<p>There are various options for improving the energy balance of MOVITRAC® B:</p> <ul style="list-style-type: none"> – Process adaptation – Energy saving function – DC link coupling – Regenerative power supply, size 2 and up (5.5 kW, MOVIDRIVE® MDR regenerative power supply module)
safetyDRIVE Functional safety	Standard version: Safe Torque Off (STO) and Safe Stop (SS12) up to PL d according to EN ISO 13849-1 for 3 x AC 230 V / 400 V units of 0.55 up to 75 kW (optionally 230 V up to 2.2 kW and 400 V up to 4 kW)
	For information on operating explosion-proof motors with frequency inverters or drive inverters, refer to page 119

¹⁾ with reduced command set

²⁾ with appropriate external control

Options for MOVITRAC® B

Type designation	
Keypad – FBG11B – DBG60B	Standard keypads for parameterization, data management, startup, and diagnostics: – Pluggable basic keypad – Plain text keypad
Parameter module UBP11A	Simplified data backup with option for series startup
Communication modules – FSC11B / FSC12B – FSE24B	– SBus / RS485 / CANopen – EtherCAT®
Fieldbus connection – DFE32B – DFE33B – DFE24B – DFP21B – DFD11B	– PROFINET IO – Modbus TCP / EtherNet/IP™ – EtherCAT® – PROFIBUS DPV1 – DeviceNet™ (CANopen integrated in basic unit)
Expansion for inputs and outputs – FIO11B – FIO21B	– Analog module with setpoint input, analog output and RS485 interface – Digital module with 7 digital inputs and SBus connection
Setpoint adjuster MBG11A	Remote speed control in the range of -100% to +100%
Interface adapter – UWS11A / UWS21B – USB11A	– Signal conversion from RS232 to RS485 – Signal conversion from USB to RS485
Safe communication – DFS11B – DFS21B	– PROFI-safe via PROFIBUS – PROFI-safe via PROFINET
safetyDRIVE Functional safety	The following versions of MOVITRAC® B are equipped with the safety function "Safe Torque Off" (STO) pursuant to EN ISO 13849-1 PL d: – 3x AC 230 V: - 0.55 kW to 2.2 kW: in SO design - 3.7 kW to 75 kW: integrated as standard – 3x AC 400 V: - 0.55 kW to 4 kW: in SO design - 5.5 kW to 75 kW: integrated as standard - 1x AC 230 V: STO not available
Other safety options – UCS..B – BST brake module	– Safe torque off: STO – Safe stopping: SS1/ SS2 – Safe operation stop: SOS – Safe motion: SLA / SLS / SDI – Safe positioning: SLP / SLI – Safe signaling: SCA / SSM – Safe stop: SBC

6.1 Control cabinet installation

Options for MOVITRAC® B

MOVI-PLC® advanced controller – DHE21B/DHE41B – DHF21B/DHF41B – DHR21B/DHR41B	Control technology – Controller performance class “advanced”: – MOVI-PLC® advanced, Ethernet interface – MOVI-PLC® advanced, Ethernet / PROFIBUS / DeviceNet™ interface – MOVI-PLC® advanced, Ethernet / PROFINET/ Modbus TCP / EtherNet/IP™ interface
Engineering software MOVITOOLS® MotionStudio	The MOVITOOLS® MotionStudio program package allows you to conveniently start up, configure and run diagnostics for MOVITRAC® B frequency inverters and MOVIDRIVE® B application inverters.
Regenerative power supply MOVIDRIVE® MDR60A 15 kW – 160 kW MOVIDRIVE® MDR61B 160 kW – 315 kW	The regenerative power supply can supply multiple units with power using a central line connection. In regenerative mode, the power is fed back into the supply system. Using the MDR60A/MDR61B lets you save power and installation costs.
Braking resistors type BW	BW series braking resistors are available for regenerative operation of MOVITRAC® B frequency inverters and MOVIDRIVE® B drive inverters. Using an integrated temperature sensor, the resistor can be protected without external monitoring.
Line choke type ND	ND series line chokes increase the overvoltage protection of inverters. This is an important characteristic in rough industrial power supply systems, especially if the inverter is installed near a supply transformer.
Line filter type NF	The NF line filter series is available for EMC-compliant installation according to EN 61800-3. They suppress interference emission on the line side of inverters. These line filters ensure that limit value class C1 is maintained on the supply end.
Output choke type HD	HD series output chokes suppress interference emission emitted from unshielded motor cables. They enable the motor to meet limit value class C1 requirements in accordance with EN 61800-3 in EMC-compliant installations. Output chokes provide an alternative to shielded motor cables in EMC-compliant installations.
Output filter type HF	HF series output filters are sine filters that smooth out the output voltage of inverters. Output filters are used for group drives to suppress discharge currents in motor cables and for long motor cables to prevent voltage peaks.

MOVIDRIVE® B application inverters



MOVIDRIVE® B



Features	<ul style="list-style-type: none"> – Powerful drive inverter for dynamic applications with synchronous and asynchronous motors in the power range 0.55 to 315 kW – Great diversity of applications due to extensive expansion options with technology and communication options
Line connection	Power range kW
200 / 240 V / 3-phase	1.5 – 37
400 / 500 V / 3-phase	0.55 – 315
Standard design	<p>The units are equipped with IPOS^{plus}® integrated positioning and sequence control as standard and can be expanded by the options available. “00” at the end of the type designation indicates the standard design.</p>
Technology version with application modules	<p>In addition to the standard version, these units include the technology functions “electronic cam” and “internal synchronous operation”. The application version is indicated by “OT” following the type designation.</p> <p>The application version units also provide access to the application modules, the standardized control programs to solve sophisticated technical drive tasks, such as synchronized applications, positioning, flying saw, and winding.</p> <p>Advantages of the application module</p> <ul style="list-style-type: none"> – High functionality and user-friendly operator interface – Only parameters needed for the application have to be entered – Guided parameterization instead of complicated programming – No lengthy training, therefore quick project planning and startup – Control of all motion functions is performed directly in MOVIDRIVE® – Decentralized concepts can be implemented more easily
safetyDRIVE Functional safety	<p>MOVISAFE®: Integrated functional safety Standard design Safe Torque Off (STO) PL d according to EN 13849-1</p>
	<p>For information on operating explosion-proof motors with our inverter technology, refer to page 119</p>

6.1 Control cabinet installation

Options for MOVIDRIVE® B

Type designation	
Keypad DBG60B	Standard keypad for parameterization, data management, startup, and diagnostics
Encoder interfaces DEH11B	<ul style="list-style-type: none"> – Motor encoder connection: TTL, RS422, Sin/Cos and HIPERFACE® encoders – Distance encoder connection: TTL, RS422, Sin/Cos and HIPERFACE® encoders
DER11B	<ul style="list-style-type: none"> – Motor encoder connection: Resolver – Distance encoder connection: TTL, RS422, Sin/Cos and HIPERFACE® encoders
DEH21B	<ul style="list-style-type: none"> – Motor encoder connection: TTL, RS422, Sin/Cos and HIPERFACE® encoders – Distance encoder connection: SSI absolute encoder
DEU21B	<ul style="list-style-type: none"> – Motor encoder connection: TTL, HTL, RS422, Sin/Cos, HIPERFACE®, SSI, CAN, EnDat 2.1 encoders – Synchronous encoder connection: TTL, HTL, RS422, Sin/Cos, HIPERFACE®, SSI, CAN, EnDat 2.1 encoders
DIP11A	<ul style="list-style-type: none"> – Motor encoder connection: TTL, RS422, Sin/Cos and HIPERFACE® encoders – Distance encoder connection: SSI absolute encoders
DIP11B	<ul style="list-style-type: none"> – Distance encoder connection: SSI absolute encoder – Expansion of digital inputs and outputs: 8x inputs, 8x outputs
Fieldbus connection	
– DFE32B / DFE33B	– PROFINET IO / Modbus TCP + EtherNet/IP™
– DFE24B	– EtherCAT
– DFP21B	– PROFIBUS DPV1
– DFC11B / DFD11B	– CANopen / DeviceNet™
– DFI11B / DFI21B	– INTERBUS / INTERBUS-FOC
– DFS11B / DFS21B	– PROFIsafe via PROFIBUS / PROFIsafe via PROFINET
MOVISAFE® safety monitor	Safe movement/position monitoring, safe inputs and outputs up to PL e according to EN ISO 13849-1 and
– DCS31B	– for “safe motion/position monitoring”
– DCS21B + DFS12B	– for “safe movement/position monitoring and communication” (PROFIsafe/PROFIBUS)
– DCS21B + DFS22B	– for “safe movement/position monitoring and communication” (PROFIsafe/PROFINET)
Expansion for inputs and outputs	8 x digital inputs and 8 x digital outputs; 1 x analog differentiation; 2 x analog outputs
– DIO11B	
MOVI-PLC® controller	
– DHE21B/DHE41B	– MOVI-PLC® advanced, Ethernet interface
– DHF21B/DHF41B	– MOVI-PLC® advanced, Ethernet / PROFIBUS / DeviceNet™ interface
– DHR21B/DHR41B	– MOVIPLC® advanced, Ethernet / PROFINET / Modbus TCP / EtherNet/IP™ interface
– External option: UHX71B	<ul style="list-style-type: none"> – Compact controller: - MOVI-PLC® power: IEC-61131-3 programmable motion and logic controller or - CCU power: parameterizable application controller
Other	
– DRS11B	– Synchronous operation card
– USB11A	– Interface adapter for connection to a PC via USB interface
– UWS21B	– Interface adapter for connection to a PC via RS232 interface

Engineering software MOVITOOLS® MotionStudio	The MOVITOOLS® MotionStudio program package allows you to conveniently start up, configure and run diagnostics for MOVITRAC® B frequency inverters and MOVIDRIVE® B application inverters.
Regenerative power supply MOVIDRIVE® MDR60A 15 kW – 160 kW MOVIDRIVE® MDR61B 160 kW – 315 kW	The regenerative power supply can supply multiple units with power using a central line connection. In regenerative mode, the power is fed back into the supply system. Using the MDR60A/MDR61B lets you save power and installation costs.
Braking resistors type BW	BW series braking resistors are available for regenerative operation of MOVITRAC® B frequency inverters and MOVIDRIVE® B drive inverters. Using an integrated temperature sensor, the resistor can be protected without external monitoring.
Line choke type ND	ND series line chokes increase the overvoltage protection of inverters. This is an important characteristic in rough industrial power supply systems, especially if the inverter is installed near a supply transformer.
Line filter type NF	The NF line filter series is available for EMC-compliant installation according to EN 61800-3. They suppress interference emission on the line side of inverters. These line filters ensure that limit value class C1 is maintained on the supply end.
Output choke type HD	HD series output chokes suppress interference emission emitted from unshielded motor cables. They enable the motor to meet limit value class C1 requirements in accordance with EN 61800-3 in EMC-compliant installations. Output chokes provide an alternative to shielded motor cables in EMC-compliant installations.
Output filter type HF	HF series output filters are sine filters that smooth out the output voltage of inverters. Output filters are used for group drives to suppress discharge currents in motor cables and for long motor cables to prevent voltage peaks.

6.1 Control cabinet installation

MOVIAXIS® multi-axis servo inverter



Features

- Multi-axis servo system for highly dynamic applications up to 250 A motor current
- Power supply and regenerative power supply up to 187 kW
- DC link power supply for DC 24 V
- Capacitor and buffer module
- Connection of all common motor and distance encoders
- Fieldbus interfaces, fieldbus gateways and clock-synchronized interfaces
- Scaled motion and logic controller directly at the axis system, speed control, positioning, motion control and kinematics
- Wide range of accessories: Cables, braking resistors, line filters, line chokes, brake control units

Power supply module type

Line connection V	3x AC 380 – 500
Nominal power kW	10, 25, 50, 75 kW at 250% for 1 s

Block-shaped power supply and regenerative power supply module

Line connection V	3x AC 380 – 500
Nominal power kW	50, 75 at 250% for 1 s

Sinusoidal power supply and regenerative power supply module

Line connection V	3x AC 380 – 480
Nominal power kW	50, 75 at 200% for 1 s

DC link power supply unit

Supply	Directly from DC link
Nominal power	3 x 10 A, limited to 600 W total power

Axis modules

Output current A at 8 kHz	2, 4, 8, 12, 16, 24, 32, 48, 64, 100 at 250% for 1 s
Communication interfaces	PROFIBUS, EtherCAT®
Encoder interfaces motor encoder	
Encoder interfaces distance encoder	
safetyDRIVE Functional safety	<ul style="list-style-type: none"> – MXA80 without integrated functional safety – MXA81: Safe Torque Off (STO) up to cat. 3 according to EN 954-1 and PL d to EN ISO 13849-1 – MXA82: Safe Torque Off (STO) up to cat. 4 according to EN 954-1 and PL e to EN ISO 13849-1 – Optional MOVISAFE® UCS..B safety module: Drive safety functions (SLS, SDI, SLP, etc.) according to EN 61800-5-2

Master module

Communication gateway	DeviceNet™, Profibus, Profinet, EtherNet/IP™, Modbus TCP
Data management	Via memory card, automatic data set download when replacing the axis module
Integrated motion controller	Programmable in IEC 61131, parameterizable functionalities

6.1 Control cabinet installation

Accessories and options for MOVIAXIS®

Encoder and distance encoder card XGH11A	<ul style="list-style-type: none"> – Multi-encoder card for motor and distance encoder Hiperface®, Endat 2.1, Sin/Cos – Incremental encoder simulation – ± 10 V analog input – DC 24 V supply
Encoder and distance encoder card XGS11A	<ul style="list-style-type: none"> – Like XGH11A, additional for SSI encoders
Input/output card XIA11A	<ul style="list-style-type: none"> – 4 DI, 4 DO – 2AI, 2 AO, 12-bit resolution – DC 24 V supply
Input/output card XIO11A	<ul style="list-style-type: none"> – 8 DI, 8 DO – DC 24 V supply
Communication interface XF011A	PROFIBUS IO FIELDBUS INTERFACE, UP TO 12 MBaud
Communication interface XFE11A	Fieldbus interface for connection to EtherCAT® networks
Communication interface XSE11A	System bus option card for expansion to EtherCAT®-compatible system bus SBus ^{plus}

MOVI-PLC® controller – DHE21B/DHE41B – DHF21B/DHF41B – DHR21B/DHR41B	– MOVI-PLC® advanced, Ethernet interface – MOVI-PLC® advanced, Ethernet / PROFIBUS / DeviceNet™ interface – MOVIPLC® advanced, Ethernet / PROFINET/ Modbus TCP / EtherNet/IP™ interface Compact controller: – MOVI-PLC® power: IEC-61131-3 programmable motion and logic controller or – CCU power: parameterizable application controller
Engineering software MOVITOOLS® MotionStudio	The MOVITOOLS® MotionStudio program package allows you to conveniently start up, configure and diagnose the MOVIAXIS® multi-axis system.
Braking resistors type BW	BW series braking resistors are available for the regenerative operation of the MOVIAXIS® multi-axis system. Using an integrated temperature sensor, the resistor can be protected without external monitoring.
Line choke type ND	ND series line chokes increase the overvoltage protection of the MOVIAXIS® multi-axis system. This is an important characteristic in rough industrial power supply systems, especially if the inverter is installed near a supply transformer.
Line filter type NF	The NF line filter series is available for EMC-compliant installation according to EN 61800-3. They suppress interference emission on the line side of inverters. These line filters ensure that limit value class C1 is maintained on the supply end.

6.1 Control cabinet installation

MOVIDRIVE® MDR regenerative power supply units



MOVIDRIVE® MDR



<p>Can be used with product series</p>	<ul style="list-style-type: none"> – MOVIDRIVE® B: 0.55 – 315 kW – MOVITRAC® MC07B: 5.5 – 75 kW
<p>Features</p>	<p>Energy balance</p> <p>Braking energy from the load cycle is no longer converted into heat energy but is fed back into the grid.</p> <p>Energy recovery is particularly interesting for applications with a high energy potential of lowering/ deceleration movements of the load cycle, such as gantry cranes, storage/retrieval systems or lifting/lowering applications.</p>
<p>Regenerative power supply: For central energy supply and recovery</p>	<ul style="list-style-type: none"> – Used for central energy supply and recovery to supply the connected inverters with energy – Several MOVIDRIVE® B inverters are connected in a DC link system – Energy is exchanged between the drive axes and excess braking energy is fed back into the power supply system
<p>Regenerative power supply: Function as a brake module (only MDR60A0150)</p>	<ul style="list-style-type: none"> – Using the regenerative power supply unit as brake module means the connected inverters are not supplied with energy but only the braking energy is fed back into the power supply system – DC link supplied via the integrated input rectifier on the drive axis – Braking energy released during the application is fed back into the power supply system – The regenerative power supply unit is selected based on the braking energy released during the application, drive inverters are selected based on the motor load -> cost-optimized overall system – Example: <ul style="list-style-type: none"> - Power rating of drive inverters: 30 kW - Power rating of regenerative power supply unit: 15 kW
<p>Advantages</p>	<ul style="list-style-type: none"> – Reduced overall energy consumption – Reduced CO₂ emissions – Reduced energy costs – Cost-efficient installation – No investment in braking resistors – No braking resistors need to be installed outside the control cabinet – No heating of the environment or of the control cabinet through braking resistors – Saves control cabinet space and expenditure for ventilation

Technical data

MOVIDRIVE® type MDR..	Connection voltage V	Power range kW	Line current I_N A	Overload capacity
MDR60A0150-503-00 Size 2	3x AC 380 V – 500 V	15	– 15 As a centralized supply and regenerative power supply unit – 22 As a brake module	– 150% for 60 s As a centralized supply and regenerative power supply unit – 37 kW for 50 s As a brake module peak braking power
MDR60A0370-503-00 Size 3		37	66	150% for 60 s
MDR60A0750-503-00 Size 4		75	117	150% for 60 s
MDR60A1320-503-00 Size 6		132 – 160	260 (at 160 kW)	150% for 60 s max. continuous power 125%
MDR61B1600-503-00 Size 7		160 – 315	250	
MDR61B2500-503-00 Size 7			400	

6.1 Control cabinet installation

Regenerative power supply for MOVIDRIVE® B

Regenerative power supply: Function as a brake module

- Braking energy released during the application is fed back into the power supply system
- The regenerative power supply unit is selected based on the braking energy
- Drive inverters are selected based on the motor load
- DC link supplied via the integrated input rectifier on the drive axis

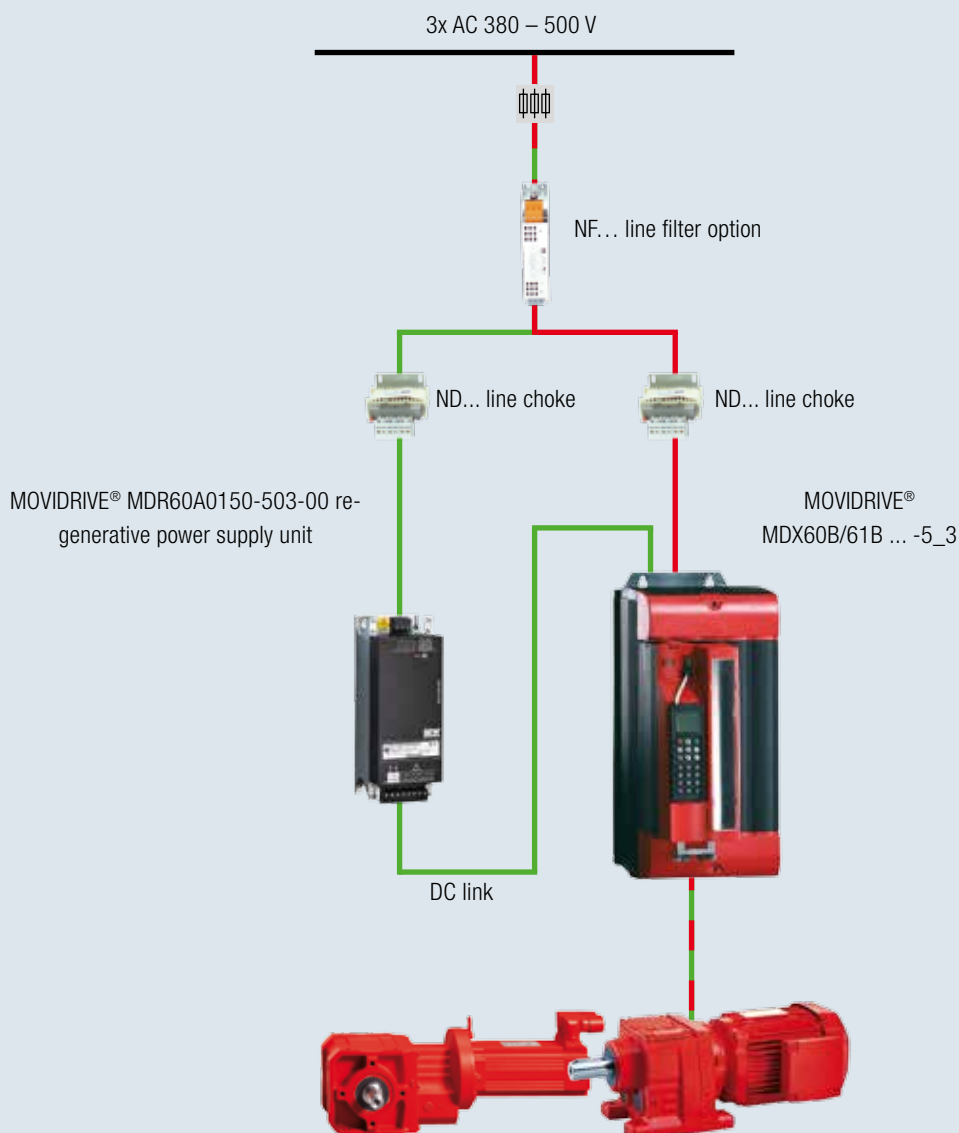

- Reduced overall energy consumption
- Reduced CO₂ emissions
- Reduced energy costs
- Cost-efficient installation
- No investment in braking resistors
- No braking resistors need to be installed outside the control cabinet
- No heating of the environment or of the control cabinet through braking resistors
- Saves control cabinet space and expenditure for ventilation

Regenerative power supply for MOVIDRIVE® MDR

Regenerative power supply: Function as a centralized supply and regenerative power supply unit

- Braking energy released during the application is fed back into the power supply system
- The regenerative power supply unit is selected based on the motor load
- The DC link is supplied via regenerative power supply
- Less installation work by connecting several drive axes to a central regenerative power supply
- Central exchange of energy between the drive axes

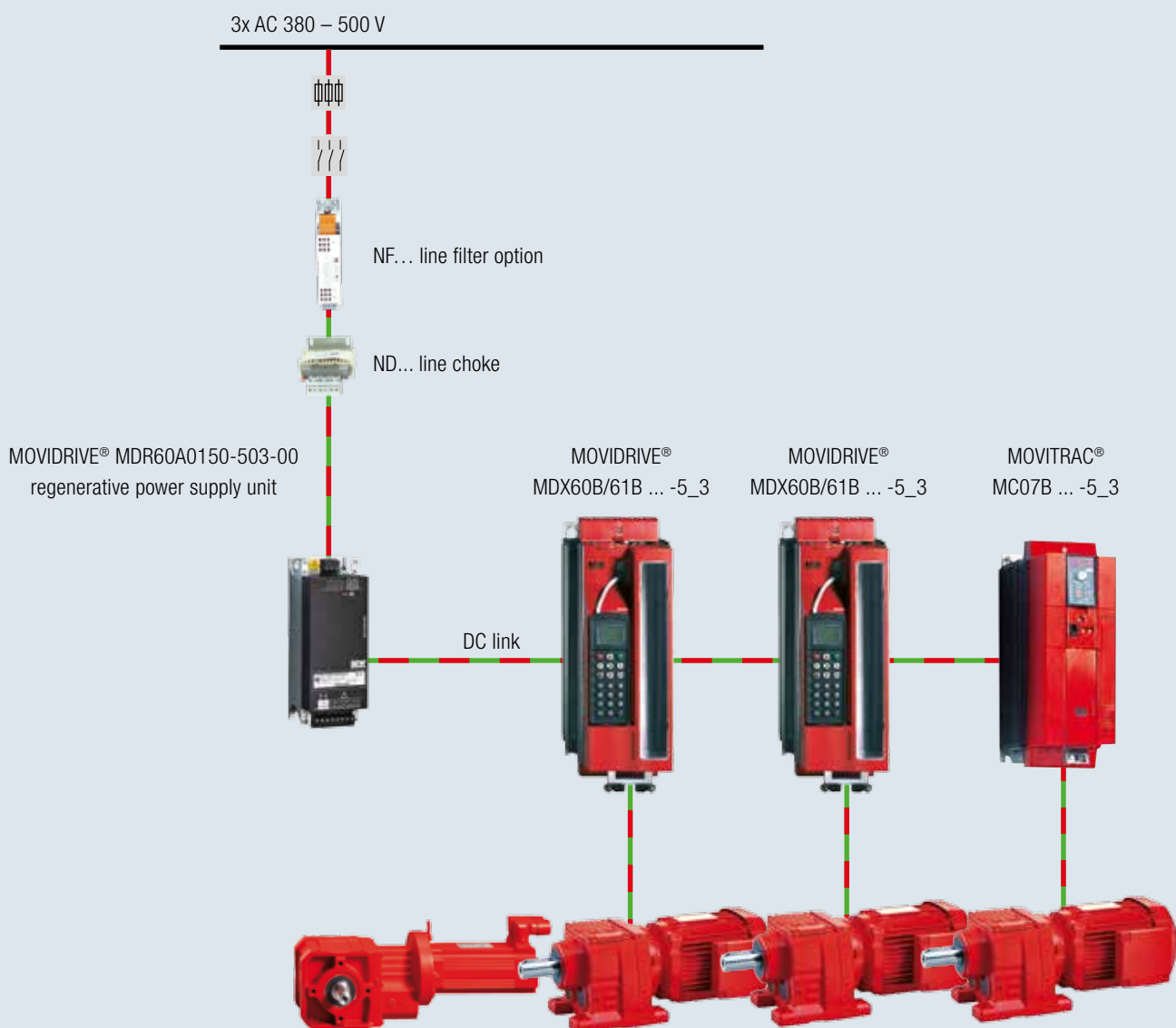

- Reduced overall energy consumption
- Reduced CO₂ emissions
- Reduced energy costs
- Cost-efficient installation
- No investment in braking resistors
- No braking resistors need to be installed outside the control cabinet
- No heating of the environment or of the control cabinet through braking resistors
- Saves control cabinet space and expenditure for ventilation

6.1 Control cabinet installation

Regenerative power supply + motor inverter up to 315 kW



Regenerative power supply MOVIDRIVE® MDR61B



Features	<ul style="list-style-type: none"> – Energy-efficient and optimized overall concept: MOVIDRIVE® B product series extended by regenerative power supply units and corresponding motor inverters in the power range from 160 to 315 kW – Particular interesting for applications with potential energy, such as in hoists, cranes and gantries, or in trolleys with high kinetic energy produced through electrical braking 	
Functions	<ul style="list-style-type: none"> – Used as central regenerative power supply for connected standard inverters or motor inverters – Energy is fed back into the grid when the application is operating as a generator, e.g. during electrical braking – Braking energy is no longer converted into heat but is fed back into the grid for further use 	
Advantages	<ul style="list-style-type: none"> – Significant reduction of the overall energy consumption / of CO₂ emissions / of energy costs – No braking resistors are required <ul style="list-style-type: none"> - No investment costs for braking resistors - No installation effort for external braking resistors - No heating up of the environment through braking resistors – Sinusoidal line current = controlled energy recovery – With coated printed-circuit boards as standard for demanding ambient conditions – Simple installation and wiring: integrated PWM filter / integrated choke / integrated and automatic DC link precharge / integrated line contactor – Modular power section, which means not the entire unit needs to be replaced in the event of service – EMC limit value class C3 (EN 61800-3) with the standard unit <ul style="list-style-type: none"> - On supply system end: without any measures → no external line filter necessary - On motor end: with shielded motor cables and output choke 	
Type designation	MDR61B1600-503-00/L	MDR61B2500-503-00/L
Connection voltage	3x AC 380 V – 500 V	
Nominal power kW	160	250
Line current/nominal motor power I_N A	250	400
Maximum continuous power	125% I _N	
Overload capacity	150% I _N for 60 s	
External accessories for control cabinet installation	<ul style="list-style-type: none"> – Mounting base – Air duct – Connection kit – Touch guard (IP20 kit) – DC link coupling 	



Motor inverter MOVIDRIVE® MDX62B



Features	<ul style="list-style-type: none"> – Energy-efficient and optimized overall concept: MOVIDRIVE® B product series extended by regenerative power supply units and corresponding motor inverters in the power range from 160 to 315 kW – Particular interesting for applications with potential energy, such as in hoists, cranes and gantries, or in trolleys with high kinetic energy produced through electrical braking 		
Functions	<ul style="list-style-type: none"> – MOVIDRIVE® B standard inverter without input stage for connection to the MOVIDRIVE® B MDR61B regenerative power supply 		
Advantages	<ul style="list-style-type: none"> – Cost-optimized MOVIDRIVE® B standard inverter without input subassemblies – Simple installation – DC link connection via conductor rail – All MOVIDRIVE® B option cards can be used 		
Type designation	MDX62B1600-503-4-0T/L	MDX62B2000-503-4-0T/L	MDX62B2500-503-2-0T/L
Connection voltage	Connection to regenerative power supply MDR61B		
Nominal power kW	160	200	250
Line current/nominal motor power I_N A	300	380	470
Maximum continuous power	125% I_N		
Overload capacity	150% I_N for 60 s		
Internal options	Utilization of all MOVIDRIVE® B option cards for connection to fieldbus systems and evaluation of motor or distance encoders (see MOVIDRIVE® B options)		
External accessories for control cabinet installation	<ul style="list-style-type: none"> – Mounting base – Air duct – Connection kit – Touch guard (IP20 kit) – DC link adapter – DC link coupling 		

6.1 Control cabinet installation

effiDRIVE®: Energy efficiency in the control cabinet

 <p>The perfect drive solution for applications from simple speed control to dynamic positioning</p>	Process adaptation	Energy saving function	DC link coupling	Regenerative power supply	Thermally controlled fans
 <p>MOVITRAC® LTP-B – Adjusted range of functions for simple applications</p>	✓	✓	✓		
 <p>MOVITRAC® B – Compact design with complete range of functions – Cost-efficient choice for standard tasks</p>	✓	✓	✓	✓	✓
 <p>MOVIDRIVE® B – High basic functionality with wide range of options – Cost-effective choice for complex systems</p>	✓	✓	✓	✓	✓

Process adaptation

- Almost every process can be adapted to the actual demand thanks to infinitely variable speed and torque control, which makes the process more energy efficient. Depending on the application, energy savings of up to 70% can be achieved.
- More energy-saving potential can be tapped in applications with periodic acceleration and deceleration through energy-efficient motion sequences. Maximum acceleration, speed and braking deceleration are not always necessary.

Energy saving function

- The energy saving function of MOVITRAC® B and MOVIDRIVE® B offers advantages when the application has to be operated in the part-load range and dynamic Features are not a main requirement when load changes occur.
- The dynamic adjustment of the magnetization current enables the motor to be operated with optimum efficiency in every operating point. The energy consumption is reduced by up to 30% depending on the application.
- The energy saving function ensures optimum efficiency of the drive especially in conjunction with an energy-efficient motor.

DC link coupling

- By connecting the DC links of several inverters, regenerative energy of one drive can be used directly as motor energy in another drive.
- This measure can reduce energy consumption from the supply system if the drive sequences are segmented and suitable travel profiles have been selected.
- MOVI-PLC®: In storage and retrieval systems, the decentralized control guarantees intelligent control of the travel profile as well as optimal energy coupling.

Regenerative power supply

- A regenerative power supply unit feeds back the regenerative energy of a drive into the supply system.
- The released braking energy is not dissipated via braking resistors but fed back into the supply system, which saves energy.
- This is especially effective in hoists as well as storage and retrieval units.

Thermally controlled fans

- The fans are switched on only when actual waste heat is generated. Not only does this lower energy consumption, it also increases the service life of the fan.
-

6.1 Control cabinet installation

effiDRIVE® – Energy efficiency in servo applications



Features

The crucial part of energy efficient operation of servo drive technology is the detailed planning and fulfilment of process and efficiency requirements. With the energy efficiency concept effiDRIVE® for servo applications, SEW-EURODRIVE offers comprehensive consulting during the planning of new plants and the modernization of existing systems. With our great expertise regarding drive technology and the industry, we focus on efficiency already during the first steps of selecting the used technology and products in order to optimize the energy consumption. But it is not sufficient to only combine energy efficient components. Only looking at the application in its entirety allows for the maximum energy efficiency.

Energy-efficient components

Sine-shaped regenerative power supply modules MXR80A	<ul style="list-style-type: none"> – In regenerative operating states, the braking energy is fed back into the supply system – Energy supply and energy recovery are sinusoidal with $\cos \phi = 1$ – Almost complete avoidance of supply harmonics – No interference of sensitive electronic devices in direct vicinity – Determination of energy flow, detailed diagnostic information – Controlled DC link voltage independent of link voltage
Block-shaped regenerative power supply modules MXR81A	<ul style="list-style-type: none"> – In regenerative operating states, the braking energy is fed back into the supply system – Inexpensive alternative to sinusoidal regenerative power supply if the supply system conditions are stable – Automatic deactivation of the recovery during motoring operation – Emergency braking resistor can be connected
MXC80A capacitor module	<ul style="list-style-type: none"> – DC link energy is absorbed or supplied with up to 50 kW – Up to 1000 Ws can be stored in the module – The charging of the module is actively via charging connection – With adequate project planning, the braking energy can be completely recycled for the next travel order – There is no need for braking resistors – Especially suited for cycles with small drives
MXP81A compact power supply module	<ul style="list-style-type: none"> – Combination of 10 kW power supply module and 250 Ws capacitor module – Especially cost-effective and space-saving with small systems – Size-optimized braking resistor is already integrated in the module

6.2 Wall mounting

MOVI4R-U® basic inverters



MOVI4RU® in IP54

Features	<ul style="list-style-type: none"> – Optimum solution to fulfill the basic requirements in drive technology: simple speed control of asynchronous motors – Intuitive operating concept for short startup times and simple handling – High degree of protection IP54 – Modular design for quick unit replacement – Faster and easier replacement of the power section for servicing – Guaranteed integration into recycling systems
Line connection	Power range kW
1-phase / 220 – 240 V	0.25 – 0.55
3-phase / 220 – 240 V	0.25 – 0.55
3-phase / 380 – 500 V	0.25 – 1.1
Features	<ul style="list-style-type: none"> – Frequency inverter with V/f control – Control plate with control knob as combination of adjusting knob and push button – Control and setpoint selection: <ul style="list-style-type: none"> - with digital inputs and fixed setpoints - setpoint selection with analog input - manual mode with control plate – MOVI4RU® is based on a sustainable product concept that allows for re-integration into material and raw material cycles. For more information, refer to www.sew-eurodrive.com

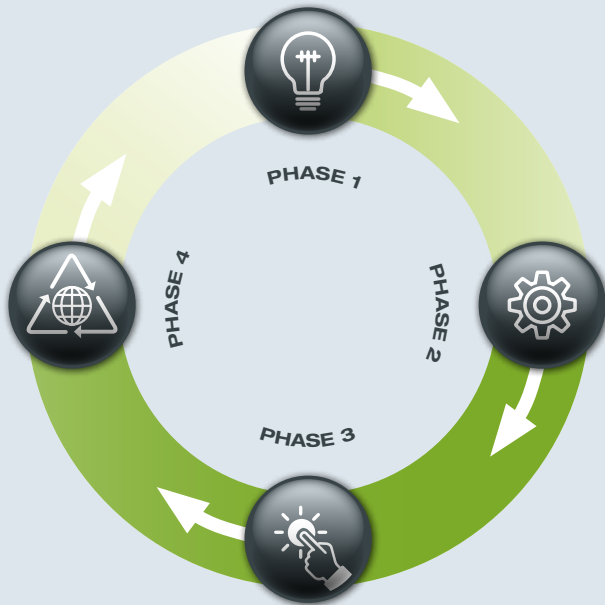

**Sustainable product life cycle of
MOVI4RU® for optimum conservation of resources**

<p>Phase 1 Development</p>	<ul style="list-style-type: none"> - Choice of environmentally friendly materials - Low material and raw material intensity - Reduced material diversity, simple separability
<p>Phase 2 Manufacturing</p>	<ul style="list-style-type: none"> - Resource-efficient production and logistics concepts - Use of renewable energies - Low transport intensity with local manufacture - Use of more environmentally friendly manufacturing processes
<p>Phase 3 Use</p>	<ul style="list-style-type: none"> - High energy-efficiency in the operating phase - Optimized product life: durable, maintenance-friendly, expandable - Technical upgrade possible (without having to replace the entire unit) - effiDRIVE® energy saving consultation for support
<p>Phase 4 Re-integration</p>	<ul style="list-style-type: none"> - Designed to make disposal easier - Re-integration and recycling of components in material and raw material cycles - Environmentally sound waste disposal

Recycling processes:



Today's products are tomorrow's raw materials:

We are happy to arrange a homogenous separation and correct re-integration of the materials used in the MOVI4R-U® in the material cycles – feel free to contact us!

The basic inverter has been scientifically tested in a life-cycle assessment study carried out by the Institute for Industrial Ecology of the Pforzheim University.

MOVI4R-U® achieved first successes and was won the "Nachhaltige Produktion Award 2014" (sustainable production award) at the "Industrial Green-Tech-Conference" at the Hannover Trade Show 2014.

6.2 Wall mounting

MOVITRAC® LTE-B basic inverters



MOVITRAC® LTE-B in IP66

**Line connection / power range
kW**

- 115 V / 1-phase: 0.37 – 1.1
- 230 V / 1-phase: 0.37 – 4.0
- 230 V / 3-phase: 1.5 – 4.0
- 400 V / 3-phase: 0.75 – 11.0

➔ More information on MOVITRAC® LTE-B in IP20: Page 180

MOVITRAC® LTP-B standard inverters



MOVITRAC® LTP-B in IP55

**Line connection / power range
kW**

- 230 V / 1-phase: 0.75 – 2.2
- 230 V / 3-phase: 0.75 – 75
- 400 V / 3-phase: 0.75 – 160
- 575 V / 3-phase: 0.75 – 110

Features

- Flexible, simple and safe:
- Standard design in degree of protection IP55 / NEMA 12k housing for wall mounting
 - Optionally also available in degree of protection IP20/NEMA for control cabinet installation
 - Control of synchronous and asynchronous motors without encoder (V/f, VFC, VFC torque)

Configuration

- Control plate for easy startup
- Overload capacity up to 175%
- Integrated EMC filter for AC 230 V and AC 400 V
- Analog and digital interfaces
- PID controller
- Compatible with all common fieldbuses directly via CANopen or via gateway PLC / option card
- Safe Torque Off / STO according to EN ISO 13849-1 PL d and EN 61508 (1-7) integrated SIL 2

MOVITRAC® LTP-B standard inverters

Options	
LT ZBG OLED A	Remote OLED full text keypad in IP54
LT BG-C	Remote keypad in IP54
LT BP-C	Bluetooth® parameter module (parameterization, data backup)
USB11A	Interface adapter (parameterization, data backup)
OP LT...	Cable sets communication
DFx.. /UOH...	Gateways for connecting fieldbuses in the control cabinet
LT FP / LT FD / LT FB / LT FE	In preparation: Option cards for direct connection of single inverters to fieldbuses
OB LT EN...	In preparation: Option cards for connection of HTL and TTL encoders
OB LT 3ROUT-A	Relay option card
OB LT IO-A	Additional I/O option card
BW..	Braking resistors
ND LT..	Line chokes
HD LT..	Output chokes
LTZ SB LTX	Shield terminal for IP20 / NEMA 1 housing

6.3 Decentralized installation: Motor starters

Basic motor starters MOVIFIT® basic



Features	<p>Minimum effort – maximum benefit:</p> <ul style="list-style-type: none"> – Integrated FieldPower® contact block for energy distribution with modern and reliable connector technology – Simple connection and wiring technology – Systematic integration of energy distribution components in the housing of the drive unit – Consistent use of standard plug connectors for control and motor connection – Extremely short assembly and installation times – In connection with AS-Interface, two sensors can, in addition to the drive function, be connected to the unit for direct communication with the system controller (everything included)
-----------------	---

Technical data

Function	Reversing	Duo	Reversing	Duo
Control	AS-Interface		Binary control signals	
Type designation	MBS4RA-K1-A1	MBS4DA-K1-A1	MBS4RA-B1-A1	MBS4DA-B1-A1
Max. motor power kW	4	2x 2.2	4	2x 2.2
Connection voltage V_{AC}	AC 3x 380 -10% – 480 + 10%			
Line frequency Hz	50 / 60			
Line connection / cable cross section	FieldPower® contact block*			
Line protection	External			
Nominal output current A	10	2x 5	10	2x 5
Controller connection	M12 plug connector 1x male / 2x female		M12 plug connector 2x male / 1x female	
Inputs and outputs	2 digital inputs for connecting external sensors		<ul style="list-style-type: none"> – 3 control inputs – 1 digital output – DC 24 V output 	
Brake control	<ul style="list-style-type: none"> – Supply via motor connection – Brake voltage = line voltage – BG rectifier in motor terminal box 			
Dimensions L x W x H mm	255 x 150 x 159			

* Copyright Weidmüller Interface GmbH & Co.

MOVI-SWITCH® motor starter



Features

- Gearmotor with switching and protection function integrated in the motor terminal box
 - 2-, 4- and 6-pole
 - Power range 0.09 to 3.0 kW
-



- For more information regarding
- **MOVI-SWITCH®: Page 175**
 - **Fieldbus interfaces, field distributors, cable systems: Page 164**

6.3 Decentralized installation: Motor starters

MOVIFIT® SC motor starter



Features

- Electronic (contactless) motor starter with one or two directions of rotation
- Parameterizable soft startup time
- Integrated brake management
- Increased safety through switching of 3 phases
- integrated energy distribution with line protection up to 6 mm²
- Optional maintenance switch
- CAN/SBus interface for external components
- Free programming according to IEC 61131
- Integrated parameter memory
- Comprehensive diagnostics via LEDs
- Expanded parameterization and diagnostics via MOVITOOLS® MotionStudio or fieldbus
- Robust aluminum housing
- Degree of protection IP65 (optional IP69K)
- Approval: ,  and 
- Optional Hygienic^{PLUS} design, i.a. degree of protection IP69K

Technical data

Power range

- With 2 connected motors (dual-motor starter) → one direction of rotation:
0.37 – 1.5 each
- With 1 connected motor (reversing starter) → two directions of rotation:
0.37 – 3.0 each

Voltage range

3 x AC 380 V – 500 V / 50 Hz – 50 Hz

Digital inputs/outputs

- 6 DI + 2 DI/O with classic function level
- 12 DI + 4 DI/O with classic function level and PROFINET fieldbus
- 12 DI + 4 DI/O with technology function level

Communication

PROFIBUS, PROFINET, PROFIsafe, DeviceNet™, EtherNet/IP™ and Modbus/TCP, PROFINET interface SCRJ / POF

Connection variants

- Motor starter consists of EBOX = electronics unit and ABOX = connection box:
- MOVIFIT® standard connection box: via cable glands
 - MOVIFIT® hybrid connection box: with variable connector configuration

MOVIFIT® function level

Indicates the functional level of the software assigned to the MOVIFIT® units regarding

- Operation
- Local system control
- Diagnostics

Classic	Technology
Simple functions	Free programming (MOVI-PLC®/MOVITOOLS® MotionStudio)
<ul style="list-style-type: none"> – “Easy mode”: Easy startup via DIP switches possible – Standardized drive functions – Controlled as field bus gateway – Extended configuration and diagnostics options via gateway configurator 	<ul style="list-style-type: none"> – Programming in accordance with IEC 61131 (e. g. in FBD, LD, IL, ST, SFC) – MOVITOOLS® MotionStudio with PLC Editor, Application Builder, etc. – Multi-level library concept (application and program modules of the MOVI-PLC® controller series) – Decentralized processing of digital inputs and outputs in the software

6.4 Decentralized installation: Inverters

Basic inverters MOVIFIT® basic



Features	Simple user interfaces for short installation times Integrated FieldPower® contact block for energy distribution with modern and reliable connector technology <ul style="list-style-type: none"> – Simple connection and wiring technology – Systematic integration of energy distribution components in the housing of the drive unit – Consistent use of standard plug connectors for control and motor connection – Extremely short assembly and installation times – In connection with AS-Interface, two sensors can, in addition to the drive function, be connected to the unit for direct communication with the system controller (everything included) 			
Function	Frequency inverters with parameterizable ramps			
Control	AS-Interface		Binary control signals	
Type designation	MBF4RA-K1-A1	MBF4DA-K1-A1	MBF4RA-B1-A1	MBF4DA-B1-A1
Max. motor power kW	0.75	1.5	0.75	1.5
Connection voltage V_{AC}	AC 3x 380 -10% to 480 + 10%			
Line frequency Hz	50 / 60			
Line connection / cable cross section	FieldPower® contact block*			
Line protection	External			
Nominal output current A	2.2	4.1	2.2	4.1
Motor connection according to ISO 23570-3	1x Q8/0			
Ambient temperature	-10 °C to +40 °C			
Degree of protection	IP54			
Service interface	RS485 to RJ11 (6P4C) for connecting the LT-BG and MB-LC operator terminals			
Connection control	M12 plug connector 1x male / 2x female		M12 plug connector 2x male / 1x female	
Inputs and outputs	2 digital inputs for connecting external sensors		<ul style="list-style-type: none"> – 4 control inputs – 1 digital output – DC 24 V output 	
Brake control	<ul style="list-style-type: none"> – Brake voltage = line voltage – BG rectifier in motor terminal box 			
Dimensions L x W x H mm	255 x 150 x 159			

MOVIMOT® standard inverters



Features	The standard inverter for direct mounting to the motor or mounting close to the motor
Power range kW	<ul style="list-style-type: none"> – 3x 380 – 500 V: 0.37 – 4.0 – 3x 200 – 240 V: 0.7 – 2.2

- For more information regarding
- MOVIMOT®: Page 162
 - Fieldbus interfaces, field distributors, cable systems: Pages 164 – 165

6.4 Decentralized installation: Inverters

MOVIFIT® MC distributors for MOVIMOT®





	MOVIFIT® MC distributors – classic: for MOVIMOT®	MOVIFIT® MC controller – technology: for MOVIMOT®
Features	<ul style="list-style-type: none"> – Power, communication and function distributor for MOVIMOT® – Up to 3 MOVIMOT® units can be connected via hybrid cable – Integrated power distribution with line protection up to 6 mm² – Optional maintenance switch – Optional incremental encoder connection – Comprehensive safety functionality – All common bus systems are available – Integrated digital inputs and outputs – Integrated parameter memory – Comprehensive diagnostics via LEDs – Expanded parameterization and diagnostics via MOVITOOLS® MotionStudio or fieldbus – Plug-in interfaces for energy, motors (power rating) and IOs – Robust aluminum housing – Degree of protection IP65 – Approval: CE, UL and C 	
Technical data	<ul style="list-style-type: none"> – Power range MOVIMOT® 0.37 kW to 4 kW in two sizes – Voltage range MOVIFIT® MC 3 x 380 V to 500 V / 50 Hz to 60 Hz – 12 DI + 4 DIO (DI = digital input, DIO = digital input/output) 	

<p>Function level</p>	<p>Indicates the functional level of the software assigned to the MOVIFIT® units regarding</p> <ul style="list-style-type: none"> – Software functionality – Processing the digital inputs and outputs – Local system control – Startup operation and diagnostics <table border="1" data-bbox="576 544 1474 1290"> <tr> <td data-bbox="576 544 1023 663"> <p>MOVIFIT® MC distributors classic Simple and standardized functions</p> </td> <td data-bbox="1023 544 1474 663"> <p>MOVIFIT® MC controller technology Parameterizable application modules and free programming</p> </td> </tr> <tr> <td data-bbox="576 663 1023 1290"> <p>“Easy mode”: Easy startup via DIP switches possible</p> <ul style="list-style-type: none"> – Standardized drive functions – Controlled as field bus gateway – Extended configuration and diagnostics options via gateway-configurator </td> <td data-bbox="1023 663 1474 1290"> <p>Parameterizable application modules – standardized application functions</p> <ul style="list-style-type: none"> – Standardized functions – Control and diagnostics via fieldbus – Parameterization instead of programming – Startup and diagnostics using MOVITOOLS® MotionStudio <p>Free programming (MOVI-PLC® / MOVITOOLS® MotionStudio)</p> <ul style="list-style-type: none"> – Programming in accordance with IEC 61131 (e.g. in LD, FBD, IL, ST, SFC) – MOVITOOLS® MotionStudio with PLC Editor, Application Builder, etc. – Multi-level library concept (application and program modules of the MOVI-PLC® series of controllers) – PLCopen certified motion blocks </td> </tr> </table>	<p>MOVIFIT® MC distributors classic Simple and standardized functions</p>	<p>MOVIFIT® MC controller technology Parameterizable application modules and free programming</p>	<p>“Easy mode”: Easy startup via DIP switches possible</p> <ul style="list-style-type: none"> – Standardized drive functions – Controlled as field bus gateway – Extended configuration and diagnostics options via gateway-configurator 	<p>Parameterizable application modules – standardized application functions</p> <ul style="list-style-type: none"> – Standardized functions – Control and diagnostics via fieldbus – Parameterization instead of programming – Startup and diagnostics using MOVITOOLS® MotionStudio <p>Free programming (MOVI-PLC® / MOVITOOLS® MotionStudio)</p> <ul style="list-style-type: none"> – Programming in accordance with IEC 61131 (e.g. in LD, FBD, IL, ST, SFC) – MOVITOOLS® MotionStudio with PLC Editor, Application Builder, etc. – Multi-level library concept (application and program modules of the MOVI-PLC® series of controllers) – PLCopen certified motion blocks
<p>MOVIFIT® MC distributors classic Simple and standardized functions</p>	<p>MOVIFIT® MC controller technology Parameterizable application modules and free programming</p>				
<p>“Easy mode”: Easy startup via DIP switches possible</p> <ul style="list-style-type: none"> – Standardized drive functions – Controlled as field bus gateway – Extended configuration and diagnostics options via gateway-configurator 	<p>Parameterizable application modules – standardized application functions</p> <ul style="list-style-type: none"> – Standardized functions – Control and diagnostics via fieldbus – Parameterization instead of programming – Startup and diagnostics using MOVITOOLS® MotionStudio <p>Free programming (MOVI-PLC® / MOVITOOLS® MotionStudio)</p> <ul style="list-style-type: none"> – Programming in accordance with IEC 61131 (e.g. in LD, FBD, IL, ST, SFC) – MOVITOOLS® MotionStudio with PLC Editor, Application Builder, etc. – Multi-level library concept (application and program modules of the MOVI-PLC® series of controllers) – PLCopen certified motion blocks 				
<p>safetyDRIVE Functional safety</p>	<p>Safety functions integrated in the MOVIMOT® inverter in accordance with IEC 61800-5-2:</p> <ul style="list-style-type: none"> – Safe disconnection (STO) – Safe stopping SS1 (c) – Approval in accordance with: <ul style="list-style-type: none"> - Category 3 according to EN 954-1 - Performance level d in accordance with EN ISO 13849-1 - SIL 2 according to IEC 61800-5-2 <p>Safety options S11 and S12</p> <ul style="list-style-type: none"> – Profisafe connection or independent operation (different numbers of safe inputs and outputs) 				

6.4 Decentralized installation: Inverters

MOVIFIT® FC inverters



	MOVIFIT® FC standard inverter – classic	MOVIFIT® FC application inverter – technology
Features	<ul style="list-style-type: none"> – Decentralized frequency inverter with a wide range of functions – Constant speed control, synchronized motion, simple lifting axes – Integrated T distributor for supply and control voltage up to 6 mm² – Integrated energy efficient brake management for various brake voltages – Optional internal (integrated in ABOX) or external braking resistor – Optional maintenance switch – Optional incremental encoder connection – All common bus systems are available – Integrated parameter memory – Comprehensive diagnostics via LEDs – Expanded parameterization and diagnostics via MOVITOOLS® MotionStudio or fieldbus – Plug-in interfaces for energy, motors (power rating) and IOs – Robust aluminum housing – Degree of protection IP65 (IP69K optional) – General approvals:   und  	
Technical data	<ul style="list-style-type: none"> – Power range from 0.37 to 4 kW <ul style="list-style-type: none"> - Size BG1: 0.37 kW to 1.5 kW - Size BG1: 2.2 kW to 4.0 kW – Voltage range 3 x 380 V to 500 V / 50 Hz to 60 Hz – 12 DI + 4 DI/O with classic function level and PROFINET fieldbus – 6 DI + 2 DI/O with classic function level – 12 DI + 4 DI/O (DI = digital input, DI/O = digital input/output) with function level technology 	

Function level	Indicates the functional level of the software assigned to the MOVIFIT® units regarding <ul style="list-style-type: none"> – Software functionality – Processing the digital inputs and outputs – Local system control startup – Operation and diagnostics 	
	MOVIFIT® FC standard inverter – classic Simple and standardized functions	MOVIFIT® FC application inverter Technology Parameterizable application modules: <ul style="list-style-type: none"> – Standardized functions – Control and diagnostics via fieldbus – Parameterization instead of programming – Startup and diagnostics using MOVITOOLS® MotionStudio
safetyDRIVE Functional safety	Safety functions integrated in the MOVIMOT® inverter in accordance with IEC 61800-5-2: <ul style="list-style-type: none"> – Safe disconnection (STO) – Safe stopping SS1(a) & SS1(c) – Safe motion (SDI, SLS) – Approval in accordance with: <ul style="list-style-type: none"> - Category 3 according to EN 954-1 - Performance level d in accordance with EN ISO 13849-1 - SIL 2 according to IEC 61800-5-2 Safety options S11 and S12 <ul style="list-style-type: none"> – Profisafe connection or independent operation (different numbers of safe inputs and outputs) 	

6.4 Decentralized installation: Inverters

MOVIPRO® standard and application inverters



MOVIPRO®

	Standard inverter MOVIPRO® SDC – Decentralized drive inverter with positioning control	Application inverters MOVIPRO® ADC – Compact and freely programmable controller for decentralized drive technology
Features	<ul style="list-style-type: none"> – Speed control and positioning – Optional encoder feedback for motor and track – Integrated brake control with various brake voltages – Optional regenerative power supply (only ADC) – Fieldbus interfaces: PROFIBUS, PROFINET, PROFIsafe, EtherNet/IP™, Modbus/TCP, DeviceNet™ – Integrated digital inputs and outputs – Optional RS485, SBus, and SBUS^{PLUS} interfaces for external actuators and sensors – Plug-in interfaces for energy, motors (power), and encoders (signals) – Local memory for parameters – Degree of protection IP54 – Robust aluminum housing – Optional maintenance switch – Optional, separable connection unit for linear power bus 	
Technical data	<ul style="list-style-type: none"> – Power range from 2.2 to 15 kW <ul style="list-style-type: none"> - Size BG0: 2.2 kW - Size BG1: 4 kW, 7.5 kW - Size BG2: 11 kW, 15 kW – Voltage range 3 x 380 V to 500 V / 50 Hz to 60 Hz – 12 DI + 4 DI/O with classic function level and PROFINET fieldbus 	
safetyDRIVE Functional safety	<ul style="list-style-type: none"> – Safe Torque Off (STO) up to category 3 and PL d according to EN ISO 13849-1 – Optional: Secure PROFIsafe bus system – Optional only for ADC: Safe brake control (SBC) 	

NEW: Decentralized servo inverter



MOVIAxis® MMD60B

Features

- Powerful, compact performance
- High overload capacity of up to 400%
- Available as decentralized variant installed close to the motor, or with the inverter integrated in the motor
- Fully scalable when installed close to the motor, with CM.., CMP.. and CMPZ.. with all options
- Reduced wiring work
- Direct, decentralized control of 24 V brakes possible
- Saves control cabinet space
- With EtherCAT®-compatible SBUS^{PLUS} for very extensive plants

Decentralized inverter

Designation	Maximum output current (A)
MMD60B019-5A3-4-00	19.0
MMD60B024-5A3-4-00	24.0
MMD60B036-5A3-4-00	36.0

Drive with integrated inverter

Motor	MOVIAxis® MMD60B designation		
	019	024	036
CM71L, $n_n = 4\ 500$ rpm	-	X	X
CM90L, $n_n = 4\ 500$ rpm	-	-	X
CM112L, $n_n = 1\ 200$ rpm	-	-	X
Decentralized frequency inverter for mounting close to the motor	X	X	X

Ethernet

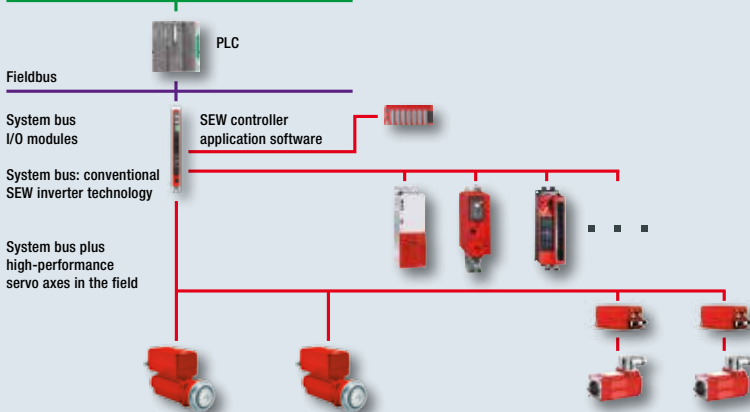

Automation concept for system and machine modules

6.5 Accessories and options

Software



MOVITOOLS® MotionStudio

Engineering software

Features

- Modular software concept for consistent engineering: Startup, control, diagnostics, communication, and visualization
 - For parameterizing, programming, and diagnosing most inverter series of SEW-EURODRIVE – independent of the device
-



MOVIVISION®
plant software

Features

- Intuitive software solution for system manufacturers and operators
- Simple and fast startup of a drive system
- Can be used at any time and any place
- No special programming knowledge is required – only parameters have to be entered

→ More information regarding software: Pages 298 – 301

07

SERVO DRIVE
TECHNOLOGY

7.1 Servo gear units		
Planetary servo gear units, PS.F, PC.C series	222	
Helical-bevel servo gear units, BS.F series	224	
7.2 Explosion-proof servo gear units	225	
7.3 Accessories and options for gear units		
Surface and corrosion protection	226	
TorqLOC® hollow shaft mounting system	229	
7.4 Servo gearmotors		
Planetary servo gearmotors, PS.F..CMP../CM../PS.C..CMP../CM.. series	230	
Helical-bevel servo gearmotors, BS..F..CMP../CM.. series	231	
Helical servo gearmotors RX/R..CMP../CM../DRL.. series	231	
Parallel-shaft helical servo gearmotors F..CMP../CM../DRL.. series	232	
Helical-bevel servo gearmotors K..CMP../CM../DRL.. series	233	
Helical-worm servo gearmotors S..CMP../CM../DRL.. series	234	
SPIROPLAN® servo right-angle gearmotors W..CMP../CM../DRL.. series	235	
7.5 Explosion-proof servo gearmotors	236	
7.6 Servomotors		
Synchronous servomotors CMP.. (high dynamics)	238	
Synchronous servomotors CM.. (high inertia)	240	
Asynchronous servomotors DRL.. series	241	
Explosions-proof motors CMP.. series	242	
7.7 Accessories and options for motors		
Cables and connection options		244
7.8 Linear motion		
SL2 synchronous linear servomotors		246
Standard CMS.. series electric cylinders		247
Modular CMSM.. series electric cylinders		250
7.9 Inverter technology		
Control cabinet installation		
Application inverter MOVIDRIVE® B		254
Regenerative power supply unit		
MOVIDRIVE® MDR60A../MDR61A..		258
Multi-axis servo inverters MOVIAXIS®		262
effiDRIVE®: Energy efficiency in servo applications		265
NEW: Decentralized servo inverter		
MOVIAXIS® MMD60B		266
Accessories and options: Software		
- MOVITOOLS® MotionStudio engineering software		267
- MOVIVISION® plant software		267





7.1 Servo gear units

Planetary servo gear units



PS.F series

Features

- Low backlash planetary servo gear units
- Designed for nominal torques from 25 Nm to 3 000 Nm
- Available in three output variants:
 - PSF = B5 output flange, smooth solid shaft (without key)
 - PSKF = B5 output flange, solid shaft with key
 - PSBF = B5 output, flange block shaft according to EN ISO 9409
- Life-long lubrication
- High permitted overhung loads

Type	Size single-stage/ two-stage	Torque class Nm	Overhung load range N	Gear unit ratios i	Rotational clearance ¹ (single-stage/two-stage)		
					Standard	Optional	
						Reduced (../R)	Minimized (../M)
PS(K)F	121 / 122	25	1 900 – 2 000	single-stage ¹⁾	8' / 10'	4' / 6'	2' / 3'
	221 / 222	55	1 720 – 2 680	3 ²⁾ , 4, 5, 7, 10	6' / 8'	3' / 4'	1' / 2'
	321 / 322	110	4 380 – 5 480				
	521 / 522	300	6 150 – 9 610				
	621 / 622	600	13 400 – 14 200	two-stage ¹⁾	4' / 6'	2' / 3'	1' / 1'
	721 / 722	1 000	25 700 – 35 900	16, 20, 25, 28,			
	821 / 822	1 750	51 400 – 62 800	35, 40, 49, 70,			
	921 / 922	3 000	55 000 – 83 300	100			
PSBF	221 / 222	55	1 530 – 5 000	single-stage	6' / 8'	3' / 4'	1' / 2'
	321 / 322	110	8 580 – 25 000	5, 7, 10			
	521 / 522	300	13 900 – 40 000				
	621 / 622	600	20 800 – 60 000	two-stage	4' / 6'	2' / 3'	1' / 1'
	721 / 722	1 000	37 900 – 120 000	15 ³⁾ , 20, 25, 35,			
	821 / 822	1 750	66 100 – 180 000	49, 70, 100			

¹⁾ Other gear ratios on request

²⁾ Only for PS(K)F 121 / 521

³⁾ Only for PSBF 322 / 522



PS.C series

Features

- Planetary servo gear units
- Designed for nominal torques between 30 Nm and 320 Nm
- Provide the basis for diverse, dynamic, and above all, **cost-optimized drive solutions**
- Compact, lightweight design
- Any mounting position
- Life-long lubrication
- Four output variants:
 - PSC = B5 output, solid shaft
 - PSKC = 5 output, solid shaft with key
 - PSCZ = 14 output flange, solid shaft
 - PSKCZ = B14 output flange, solid shaft with key

Type	Size single-stage / two-stage	Torque class Nm	Overhung load range N	Gear unit ratios i	Rotational clearance α (single-stage/double-stage)
					Standard
PS(K)C PS(K)CZ	221 / 222	30	1 170 – 2 000	single-stage	10' / 15'
	321 / 322	65	1 710 – 4 000	3 ¹⁾ , 5, 7, 10	
	521 / 522	160	2 900 – 6 750	two-stage 15 ¹⁾ , 21 ¹⁾ , 25, 30 ¹⁾ , 35, 49, 50, 70, 100	
	621 / 622	320	5 390 – 11 000		

¹⁾ Not for PS(K)C, PS(K)CZ 621 / 622

7.1 Servo gear units

Helical-bevel servo gear units



BS.F series

Features

- Low-backlash helical-bevel servo gear units
- Designed for torque classes 40 to 1 220 Nm
- 5 output variants:
 - BSF: Solid shaft
 - BSKF: Solid shaft with key
 - BSBF: Flange block shaft (EN ISO 9409)
 - BSHF: Hollow shaft with shrink disk
 - BSAF: Hollow shaft with key (shaft mounted gear unit)
- All variants with B5 mounting flange; foot-mounting and torque arm are optional (→ can be optimally integrated into the relevant application)
- The rotational clearance remains constantly low over the entire gear unit service life

Size	Torque class Nm	Gear unit ratios i	Rotational clearance `
202	40	3 / 4 / 6 / 8 / 10 / 15 / 20 / 25	6 ⁹⁾ / 3 ¹⁰⁾
302	80	3 / 4 / 6 / 8 / 10 / 15 / 20 / 25 / 30	
402	160		
502	320	3 / 4 / 6 / 8 / 10 / 12 / 15 / 20 / 25 / 30 / 35	
602	640	3 / 4 / 6 / 8 / 10 / 12 / 15 / 20 / 25 / 30 / 35 / 40	
802	1 220		

⁹⁾ Standard ¹⁰⁾ Reduced

Options for servo gear units

Direct motor mounting	Positive direct motor mounting (without terminal adapter) of the SEW servomotor series CMP.. and CM..
Motor adapter	EPH motor adapter for PS.F and PS.C planetary servo gear units, ECH motor adapter for PS.C planetary servo gear units and EBH motor adapter for BS.F helical-bevel servo gear units
Reduced backlash	Optionally for PS.F planetary servo gear units and BS.F helical-bevel servo gear units with significantly smaller rotational clearance
Minimized rotational clearance	Optionally for PS.F planetary servo gear units with even more reduced rotational clearance

7.2 Explosion-proof servo gear units

Servo gear units



	Gear units comply with directive 94/9/EC (ATEX), equipment group II, category 2, II2GD design	Certified protection types
PS.F planetary servo gear units	<ul style="list-style-type: none"> – For use on the European market – Accepted in China – Accepted in Russia in conjunction with EAC certificates (successor to GOST-R) 	<ul style="list-style-type: none"> – Protection type “c”: Protected by safe construction (design safety), EN13463-1 and -5 – Protection type “k”: Protected by liquid immersion, EN13463-1 and -8
BS.F helical-bevel servo gear units		

7.3 Accessories and options: Servo gear units

Corrosion protection (KS) and surface protection (OS) for all standard gear units



Features	SEW-EURODRIVE offers optional corrosion and surface protection measures for operating motors and gear units under special environmental conditions; in combination, they ensure optimum protection of motors and gear units.
KS corrosion protection	KS corrosion protection measures for motors: <ul style="list-style-type: none"> – All retaining screws that are loosened during operation are made of stainless steel. – The nameplates are made of stainless steel. Various motor parts are coated with a finishing varnish. – The flange contact surfaces and shaft ends are treated with a temporary rust preventive. – Band clamps as additional measures for brakemotors
OS surface protection	Motors and gear units are optionally available with surface protection OS1, OS2, OS3 or OS4 instead of the standard surface protection. This makes the gearmotors well equipped for operation under various ambient conditions.

Measures for interior treatment and standard parts

Special interior surface treatment



Brakes with pressure plate made of non-corrosive material



Rustproof nameplates



Non-corrosive retaining parts



RS bearing for IP56



Special interior surface treatment



Special interior surface treatment



Rustproof breather valves



NOCO® fluid, the contact corrosion inhibitor







Output shaft made of stainless steel



Optional coating at drive shaft end (in the area of the radial oil seal seat)







Surface protection (OS)

Surface protection		Ambient conditions/sample applications
Standard		<p>For machines and systems within buildings and interior rooms with neutral atmospheres.</p> <ul style="list-style-type: none"> – C1 (negligible)* <p>Sample applications:</p> <ul style="list-style-type: none"> – Machines and systems in the automobile industry – Conveyor systems in logistics areas – Conveyor belts at airports
OS1		<p>For environments prone to condensation and atmospheres with low humidity or contamination, such as outdoor applications under a roof or protective equipment.</p> <ul style="list-style-type: none"> – C2 (low)* <p>Sample applications:</p> <ul style="list-style-type: none"> – Systems in saw mills – Hall gates – Agitators and mixers
OS2		<p>For environments with high humidity or moderate atmospheric contamination, such as outdoor applications subject to direct weathering.</p> <ul style="list-style-type: none"> – C3 (moderate)* <p>Sample applications:</p> <ul style="list-style-type: none"> – Applications in amusement parks – Funiculars and chair-lifts – Applications in gravel plants – Systems in nuclear power plants
OS3		<p>For environments with high humidity and occasionally severe atmospheric and chemical contamination. Occasional acidic or caustic wet cleaning. Also for applications in coastal areas with moderate salt load.</p> <ul style="list-style-type: none"> – C4 (high) * <p>Sample applications:</p> <ul style="list-style-type: none"> – Sewage treatment plants – Port cranes – Mining applications
OS4		<p>For environments with permanent humidity and severe atmospheric or chemical contamination. Regular acidic and caustic wet cleaning, also with chemical cleaning agents.</p> <ul style="list-style-type: none"> – C5-I (severe) * <p>Sample applications:</p> <ul style="list-style-type: none"> – Drives in malting plants – Wet areas in the beverage industry – Conveyor belts in the food industry

7.3 Accessories and options: Servo gear units

Surface protection (OS)

Surface protection		Ambient conditions/sample applications
Aseptic motors of the DAS.. series Either OS2–OS4		Suitable for dry or wet hygienic areas with average atmospheric contamination. Also suitable for particularly dusty environments. <ul style="list-style-type: none"> – C3 (moderate)* Sample applications: <ul style="list-style-type: none"> – Applications in clean rooms – Machines in the cosmetic and pharmaceutical industry – Systems for processing cereals and flour (without Ex protection) – Conveyor belts in cement plants
Aseptic motors of the DAS.. series with drive package ASEPTICplus® OS4		For hygienic areas in the food and beverage industry with permanent humidity, regular acidic or caustic wet cleaning with chemical agents and pressure cleaning. <ul style="list-style-type: none"> – C5-I (severe) * Sample applications: <ul style="list-style-type: none"> – Hygienic and aseptic conveyors in the beverage industry – Systems in cheese dairies and meat processing plants – “Splash zones” in the food industry
High protection surface treatment HP200		For hygienic areas in the food and beverage industry with regular acidic and caustic wet cleaning. Anti-stick Features support the cleaning process even in inaccessible areas. Sample applications: <ul style="list-style-type: none"> – Hygienic and aseptic conveyors in the Beverage industry – Systems in cheese dairies and meat processing industries – “Splash zones” in the food industry
Stainless steel gearmotor		For hygienic areas in the food and beverage industry with permanent humidity and extreme acidic and caustic wet cleaning using chemical cleaning agents. Sample applications: <ul style="list-style-type: none"> – Hygienic and aseptic applications of all types – Systems in cheese dairies and meat processing industries – Food processing machines for the North American market

* In accordance with the corrosivity categories of DIN EN ISO 12944-2

TorqLOC® hollow shaft mounting system



Cost efficient	The TorqLOC® hollow shaft mounting system is used for achieving a non-positive connection between customer shaft and hollow shaft in the gear unit, optional for parallel shaft helical, helical-bevel or helical-worm gear units. An economic alternative to the previous hollow shaft with shrink disk, hollow shaft with key, and splined hollow shaft.
Simple	The drive can be installed and removed easily, even after long periods of operation. The drive is delivered with the matching bushing. The operator will install the clamping ring on the customer shaft and the drive can be mounted and fixed easily.
Economical	The TorqLOC® hollow shaft mounting system makes it possible to use drawn, unprocessed material up to quality level h11 for customer shafts, reducing costs even further. No additional machining of the customer shaft is required.
Flexible	Up to 4 different rated diameters can be adapted with one gear unit size.
Awards	The trade journal "Plant Engineering" awarded the "Product of the Year 2002". The award is given to innovative products which lead to ground-breaking improvements at the production level.

07

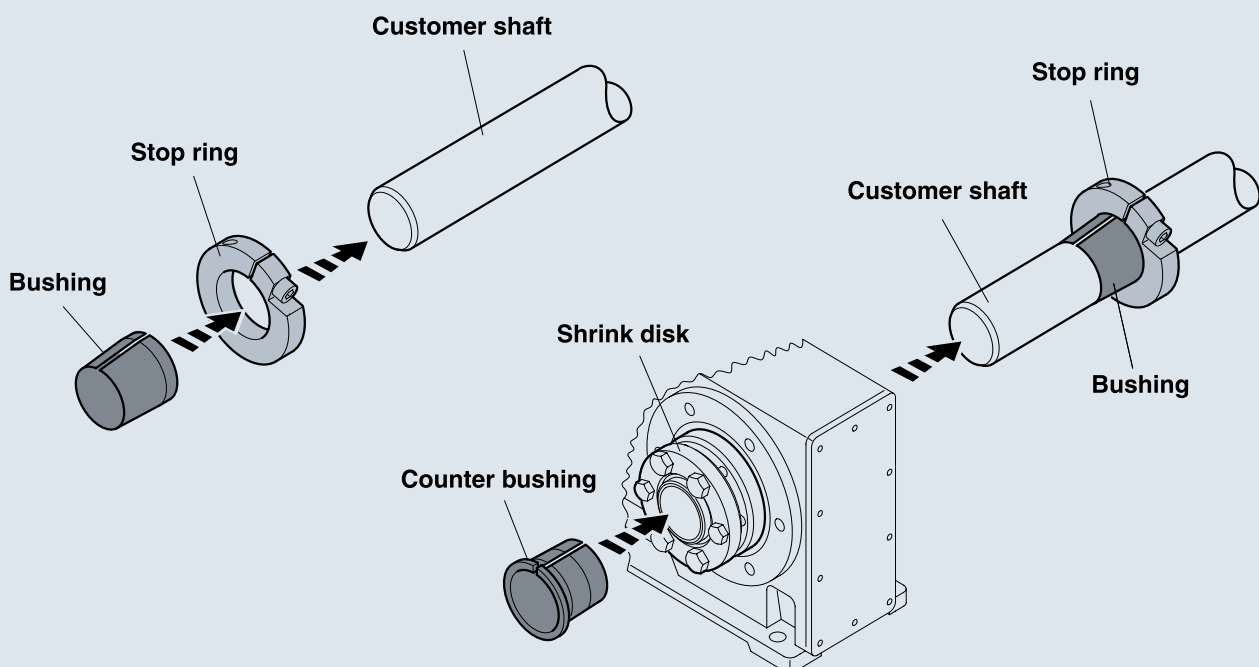

7.4 Servo gearmotors

Planetary servo gearmotors



PS.F. series

with	Torque range M_{aDyn} Nm	PS.F. gear unit sizes
CMP.. motor (high dynamics)	15 – 4 200	PS.F121 – PS.F922
CM.. motor (high inertia)	49 – 4 200	PS.F321 – PS.F922

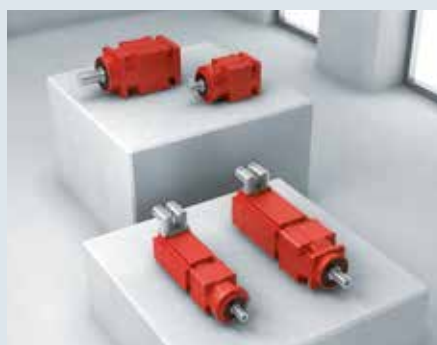

PS.C.. series

with	Torque range M_{aDyn} Nm	PS.C.. gear unit sizes
CMP.. motor (high dynamics)	15 – 425	PS.C221 – PS.C622
CM.. motor (high inertia)	49 – 425	PS.C321 – PS.C622

Helical-bevel servo gearmotors



BS.F. series

with	Torque range M_{aDyn} Nm	BS.F. gear unit sizes
CMP.. motor (high dynamics)	15 – 1 680	BS.F202 – BS.F802
CM.. motor (high inertia)	46 – 1 680	BS.F302 – BS.F802

Helical servo gearmotors



RX/R series

07

Features	<ul style="list-style-type: none"> – The RX57 to RX107 single-stage gear unit series offers compact, space-saving solutions for high output speeds – Thanks to the die-cast aluminum design, multi-stage gear units R07, R17 and R27 are ideal for use as satellite drives and for use in light machine constructions 					
	Synchronous servo gearmotors				Asynchronous servo gearmotors with DRL.. motor	
	with CMP.. motor (high dynamics)		with CM.. motor (high inertia)			
Gear unit size	RX57 – RX77	R07 – R107	RX57 – RX107	R27 – R107	RX57 – RX107	R17 – R167
Gear ratios i	1.3 – 7.63	3.21 – 216.54	1.3 – 8.23	3.37 – 216.28	1.3 – 8.23	3.37 – 255.71
Torque range M_{aDyn} Nm	6.6 – 1 120	12 – 4 360	63 – 830	45 – 4 300	63 – 830	45 – 18 000
Rotational clearance (/R option)	–	5 – 14	–	5 – 14	–	5 – 14

7.4 Servo gearmotors

Parallel-shaft helical servo gearmotors



F series

Features	– This compact gearmotor not only excels by its performance but also by its structural Features		
	Synchronous servo gearmotors		Asynchronous servo gearmotors with DRL.. motor
	with CMP.. motor (high dynamics)	with CM.. motor (high inertia)	
Gear unit size	F27 – F107	F27 – F107	F27 – F157
Gear ratios <i>i</i>	3.77 – 276.77	3.77 – 276.77	3.77 – 276.77
Torque range M_{aDyn} Nm	15 – 8 860	67 – 8 860	87 – 18 000
Rotational clearance (/R option)	5 – 12	5 – 12	5 – 12

Helical-bevel servo gearmotors



K series

Features

- Helical-bevel gear units from SEW-EURODRIVE provide a high degree of efficiency in both torque directions and at any input speed
- The gearing is designed for high endurance and makes for a high-torque, wear-free drive
- The remarkably high efficiency of the helical-bevel gearmotors of SEW-EURODRIVE makes them energy savers
- The long maintenance-free service life is another reason why they can be used with AC asynchronous motors, asynchronous and synchronous servomotors in every application

	Synchronous servo gearmotors		Asynchronous servo gearmotors		
	with CMP.. motor (high dynamics)	with CM..-Motor (high inertia)	with DRL.. motor		
Gear unit size	K37 – K107	NEW: K..19 – K..49	K37 – K107	K37 – K187	NEW: K..19 – K..49
Gear ratios i	3.98 – 174.19	2.8 – 75.0	3.98 – 176.05	3.98 – 179.86	2.8 – 75.20
Torque range M_{aDyn} Nm	15 – 9 090	16 – 605	63 – 9 090	125 – 50 000	54 – 605
Rotational clearance (/R option)	5 – 13	–	5 – 13	5 – 13	–

7.4 Servo gearmotors

Helical-worm servo gearmotors



S series

Features

- Particularly space-saving when used as angular drive
- The attenuation characteristics are another advantage
- Torque shocks are attenuated as the power transmission to the drive shaft is linear on the input shaft
- The noise level of this type is very low, even when operating the unit at full capacity
- Can be used in stage lifts, for example

	Synchronous servo gearmotors		Asynchronous servo gearmotors with DRL.. motor
	with CMP.. motor (high dynamics)	with CM.. motor (high inertia)	
Gear unit size	S37 – S67	S37 – S67	S37 – S67
Gear ratios i	3.97 – 75.06	6.80 – 75.06	3.97 – 75.06
Torque range M_{aDyn} Nm	18 – 580	43 – 480	32 – 480

SPIROPLAN® right-angle servo gearmotors



W series

Features

- SPIROPLAN® right-angle servo gearmotors with directly mounted synchronous CMP.. servomotor are extremely efficient, quiet, and offer customers the greatest possible flexibility
- SPIROPLAN® right-angle gear units W37 / W47 achieve high speeds at smallest gear ratios
- Wear-free gearing minimizes friction losses and optimizes the mechanical efficiency
- Areas of application: Ideal drives for simple positioning or conveyor applications
- Gear unit designs:
 - Foot/flange-mounted design
 - B5 flange
 - B14 flange
 - Solid shaft / hollow shaft
 - Directly mounted servomotor
 - Adapter mounting

	Synchronous servo gearmotors		Asynchronous servo gearmotors with DRL.. servomotor
	with CMP.. motor (high dynamics)	with CM.. motor (high inertia)	
Gear unit size	W37 – W47	W37 – W47	W37 – W47
Gear ratios i	3.2 – 74.98	3.2 – 51.12	3.2 – 74.98
Torque range M_{aDyn} Nm	11 – 215	49 – 215	16 – 215

7.5 Explosion-proof servo gearmotors



Gear unit	With CMP. motor (high dynamics)
Gear unit sizes	Torque range M_{aDyn} Nm
Planetary servo gearmotors PS.F121 – PS.F922	15 – 4 200
Helical-bevel servo gearmotors BS.F202 – BS.F802	15 – 1 680
Helical servo gearmotors RX57 – RX107	6.6 – 910
Helical servo gearmotors R07 – R107	12 – 4 360
Parallel-shaft helical servo gearmotors F27 – F107	15 – 8 860
Helical-bevel servo gearmotors K37 – K107	15 – 9 090
Helical-worm servo gearmotors S37 – S67	18 – 580
SPIROPLAN® right-angle servo gearmotors W10 – W47	12 – 215

7.6 Servomotors

Synchronous servomotors



CMP.. series (high dynamics)

Features

- Highest dynamic Features due to low-inertia rotor design and high overload capacity of the motors
- Performance-optimized and extremely compact design thanks to the latest winding and magnet technology
- Standstill torques from 0.5 to 95 Nm
- Optional CMPZ.. motor design with additional rotor inertia for all applications with high load moments of inertia
- Direct motor mounting to gear units from our modular gear unit system



- Europe: CE marking
- USA: UR marking
- Canada: CSA label
- EAC: Eurasian conformity



- CMP../CMPZ.. motors are available in explosion-proof design, in compliance with the 94/9/EC directive (ATEX), for sizes 40S to 100L

Type	Rated speed rpm	M_0 Nm	M_{pK} Nm	J_{mot} kgcm ²	
				CMP..	CMPZ..
CMP40S	3 000 / 4 500 / 6 000	0.5	1.9	0.10	–
CMP40M	3 000 / 4 500 / 6 000	0.8	3.8	0.15	–
CMP50S	3 000 / 4 500 / 6 000	1.3	5.2	0.42	–
CMP50M	3 000 / 4 500 / 6 000	2.4	10.3	0.67	–
CMP50L	3 000 / 4 500 / 6 000	3.3	15.4	0.92	–
CMP63S	3 000 / 4 500 / 6 000	2.9	11.1	1.15	–
CMP63M	3 000 / 4 500 / 6 000	5.3	21.4	1.92	–
CMP63L	3 000 / 4 500 / 6 000	7.1	30.4	2.69	–

Type	Rated speed rpm	M ₀ Nm	M _{pK} Nm	J _{mot} kgcm ²	
				CMP..	CMPZ..
CMP71S / CMPZ71S	2 000 / 3 000 / 4 500 / 6 000	6.4	19.2	3.1	9.32
CMP71M / CMPZ71M	2 000 / 3 000 / 4 500 / 6 000	9.4	30.8	4.1	10.37
CMP71L / CMPZ71L	2 000 / 3 000 / 4 500 / 6 000	13.1	46.9	6.1	12.47
CMP80S / CMPZ80S	2 000 / 3 000 / 4 500 / 6 000	13.4	42.1	8.8	27.18
CMP80M / CMPZ80M	2 000 / 3 000 / 4 500 / 6 000	18.7	62.6	11.9	30.3
CMP80L / CMPZ80L	2 000 / 3 000 / 4 500 / 6 000	27.5	107	18.1	36.51
CMP100S / CMPZ100S	2 000 / 3 000 / 4 500	25.5	68.3	19.59	79.76
CMP100M / CMPZ100M	2 000 / 3 000 / 4 500	31	108	26.49	86.66
CMP100L / CMPZ100L	2 000 / 3 000 / 4 500	47	178.8	40.24	100.41
NEW: CMP112S	2 000 / 3 000 / 4 500	30	88	74	–
NEW: CMP112M	2 000 / 3 000 / 4 500	45	136	103	–
NEW: CMP112L	2 000 / 3 000 / 4 500	69	225	163	–
NEW: CMP112H	2 000 / 3 000 / 4 500	83	270	193	–
NEW: CMP112E	2 000 / 3 000 / 4 500	95	320	222	–

07

safetyDRIVE

Functional safety

Optional: Integrated functional safety for CMP.. motors

	FS safety-rated encoder	Up to PL d according to EN ISO 13849-1	AK0H(FS), AK1H(FS)
	FS safety-rated brake, safety functions – SBA (Safe Brake Actuation) – Safe braking – SBH (Safe Brake Hold) – Safe Torque Off	Up to PL c according to EN ISO 13849-1	BY(FS)

7.6 Servomotors

Synchronous servomotors



CM.. series (high inertia)

Features

- Standstill torques from 5 to 68 Nm
- Compact design with high power density due to optimize magnetic circuit layout
- High overload rating and reduced losses
- Electronic nameplate for fast and simple startup
- Optional: scalable HIPERFACE® encoder and high-performance working brake



- Europe: CE marking
- USA: UR marking
- Canada: CSA label
- EAC: Eurasian conformity

Type	Rated speed rpm	M ₀ Nm	M _{pk} Nm	Inertia kgcm ²	
				J _{mot} Nm	J _{bmot} Nm
CM71S	2 000 / 3 000 / 4 500 / 6 000	5	16.5	4.99	6.72
CM71M		6.5	21.5	6.4	8.13
CM71L		9.5	31.4	9.21	10.94
CM90S		11	39.6	18.2	22
CM90M		14.5	52.2	23.4	27.2
CM90L		21	75.6	33.7	37.5
CM112S	2 000 / 3 000 / 4 500	23.5	82.3	68.9	84.2
CM112M		31	108.5	88.9	104.2
CM112L		45	157.5	128.8	144.1
CM112H		68	238	188.7	204

Asynchronous servomotors



DRL.. series

Features

- Torques from 5 Nm to 290 Nm
- High rated torques make this series perfectly suitable for high dynamic loads with Features of an asynchronous servomotor
- Loads up to 3.5 times the nominal motor torque
- Safe and precise positioning in combination with MOVIAXIS® multi-axis servo inverters or MOVIDRIVE® application inverters

Rated torque Nm	Speed class rpm	Inertia kgcm ²
2.7 – 290	1 200	5.13 – 4 360
2.7 – 280	1 700	5.13 – 4 360
2.6 – 265	2 100	5.13 – 4 360
2.5 – 220	3 000	5.13 – 4 360

Dynamics packages

Dynamics package 1	190% – 220% M_{dyn} / M_N ; normal pinion shaft end for direct gear unit mounting
Dynamics package 2	300% – 350% M_{dyn} / M_N ; reinforced pinion shaft end for direct gear unit mounting

7.6 Servomotors

Explosion-proof servomotors



CMP40 – 100 series



Compliant with directive 94/9/EC (ATEX), equipment group II, equipment category 3

- Category II 3GD, suitable for use in zones 2 / 22
- Category II 3D, suitable for use in zone 22
- In category 3D also available with brake and Hiperface® encoder (with electronic nameplate)

Protection types

Dust atmosphere: Protection type “t” indicates dust explosion protection due to housing according to EN 60079-0 and -31

Gas atmosphere: Protection type “na” indicates

- Protection due to non-sparking according to EN 60079-0 and -15
- Design measures and requirements regarding dimensioning like for protection type “e”, but only fault-free operation is considered

Dust atmosphere: Degree of protection IP65

This means:

- Dust-tight housings according to EN 60079-31
- No dust can enter the housing due to the motor housing design
- Continuous monitoring of the surface temperature to exclude this as ignition source



- Europe: CE marking
- EAC: Eurasian conformity

Explosion-proof CMP. servomotors / compliant with EC Directive 94/9/EC (ATEX)

Category	Ex marking	Product characteristics	Options	Speed class
II3D	II3D Ex tc IIIC T150 °C X** Dc	<ul style="list-style-type: none"> – ATEX motor characteristic curves (thermal + dynamic) – Overload factor 3x standstill current I_0 	<ul style="list-style-type: none"> Brake Hiperface® Resolver 	<ul style="list-style-type: none"> 2 000 3 000 4 500
II3GD	II3G Ex nA IIC T3 X** Gc II3D Ex tc IIIC T150 °C X** Dc	<ul style="list-style-type: none"> – Grounding screw – IP65 – ATEX operating instructions – No forced cooling fan 	<ul style="list-style-type: none"> Resolver 	

** In conjunction with a matching temperature model in the inverter

7.7 Accessories and options: Servomotors

Cables and connection options



CMP.. servomotor cable connections

Motor type	Power connector	Cable routing	Drive electronics
CMP40 – 63	Motor: SM1	Fixed installation or cable carrier installation	MOVIDRIVE® application inverter MOVIAXIS® multi-axis servo inverter
	Brakemotor: SB1		
CMP71 – 100	Motor: SM1, SMB	Fixed installation or cable carrier installation	MOVIDRIVE® application inverter MOVIAXIS® multi-axis servo inverter
	Brakemotor: SB1, SBB		
CMP112	Motor: SM1, SMB, SMC	Fixed installation or cable carrier installation	MOVIDRIVE® application inverter MOVIAXIS® multi-axis servo inverter
	Brakemotor: SB1, SBB, SBC		

Motor type	Encoder connector	Cable routing	Drive electronics
CMP40 – 112	RH1M resolver	Fixed installation or cable carrier installation	MOVIDRIVE® application inverter MOVIAXIS® multi-axis servo inverter
CMP40 – 63	HIPERFACE® AK0H, EK0H, AS1H, ES1H	Fixed installation or cable carrier installation	MOVIDRIVE® application inverter MOVIAXIS® multi-axis servo inverter
CMP71 – 112	HIPERFACE® AK0H, EK1H, AK1H	Fixed installation or cable carrier installation	MOVIDRIVE® application inverter MOVIAXIS® multi-axis servo inverter

DR.. AC motor cable connections: Direct connection

Motor type	Encoder type	Encoder connection	Inverter connection
DR71 – DR132	EI7C, EI76, EI72, EI71	Conductor end sleeves	Conductor end sleeves MOVIDRIVE® B application inverter
		M12 plug connector	
	ES7S, ES7R, AS7W, AS7Y	Conductor end sleeves	D-sub plug connectors MOVIDRIVE® application inverter
		Connection cover	
DR160 – DR225	EG7S, EG7R, AG7W, AG7Y	Conductor end sleeves	
		Connection cover	
DR315	EH7S	M23 plug connectors	
	AH7Y	Conductor end sleeves	

DR.. AC motor cable connections: Connection via intermediate sockets

Motor type	Encoder type	Encoder connection	Adapter plug
DR71 – DR132	ES7S, ES7R, AS7W	Conductor end sleeves	M23 plug connector (female connector)
		Connection cover	
DR160 – DR225	EG7S, EG7R, AG7W	Conductor end sleeves	
		Connection cover	

Intermediate socket

M23 plug connector (male connector)	Extension	M23 plug connector (female connector)
-------------------------------------	-----------	--

Intermediate socket

M23 plug connector (male connector)	Extension	D-sub plug connectors MOVIDRIVE® application inverter
-------------------------------------	-----------	--

7.8 Linear motion

Synchronous linear servomotors



SL2 series

Features

- Suitable application areas: highly dynamic, flexible processing machines; material handling; pick and place applications
- No mechanical transmission elements and wear parts are required as linear motion and force are generated directly
- Optimized force-density ratio due to modern winding technology and laminated iron core
- Almost maintenance-free
- High control quality, dynamics and precision
- Available in three designs (SL2 basic, SL2 advanced system, SL2 power system)
- Secondaries are available in various lengths and can easily be lined up

Product versions

Product versions	Rated power range N	Rated speed classes m/s
SL2 Basic	125 – 6 000	1 / 3 / 6
SL2 Advance System	280 – 3 600	
SL2 Power System	400 – 5 500	

Options for linear servomotors

SL2 Advance System and SL2 Power System

- The cables of the motor end have matching plug connectors
- EMC-compliant connector housing design
- Plug connectors seal the plug on the cable end with a lamellar seal and ensure strain relief in accordance with EN 61884
- Various accessories for inverter-specific prefabrication

Standard CMS.. electric cylinders / with grease lubrication



CMS50/71 series (with grease lubrication)

Features	<ul style="list-style-type: none"> – Equipped with permanent magnet rotors – Precise, powerful and fast – Combined with drive electronics from SEW-EURODRIVE, this series makes for energy-efficient drive solutions that ensure a high level of process reliability and that can be easily integrated into existing automation systems
-----------------	--

Electrical data

Type	CMS71L		
Max. torque Nm	31.4	22.1 ¹⁾	24.4 ¹⁾
Standstill torque Nm	9.5		

Mechanical data

Rated speed n_N	2 000 rpm 3 000 rpm 4 500 rpm			
Spindle type	KGT ²⁾ 32x10	KGT ²⁾ 32x6	PGT ³⁾ 24x5	
Max. continuous feed force ⁴⁾ N	3 600	6 700	7 200	
Peak feed force N	17 000	20 000	15 000 20 000 ⁵⁾	20 000
Stroke lengths mm	200	200	350	200
Max. speed mm/s	500	300	200	250

¹⁾ Maximum permitted torque

²⁾ Ball screw

³⁾ Planetary roller screw

⁴⁾ Depending on average travel speed

⁵⁾ In case of tensile loads

7.8 Linear motion

Standard CMS.. electric cylinders / with oil bath lubrication



CMSB50/63/71 series (with oil bath lubrication)

Features	<ul style="list-style-type: none"> – Patented maintenance-free oil bath lubrication (lifetime lubrication) – Very high thermal power density – Especially low-noise operation – Very short working strokes (< 1 mm) – Combined with drive electronics from SEW-EURODRIVE, this series makes for energy-efficient drive solutions that ensure a high level of process reliability and that can be easily integrated into existing automation systems
-----------------	---

Electrical data

Type	NEW: CMSB50S	NEW: CMSB50M	NEW: CMSB50L
Max. torque Nm	5.2	7 ¹⁾	7 ¹⁾
Standstill torque Nm	1.3	2.4	3.3

Mechanical data

Rated speed n_N	3 000 rpm 4 500 rpm 6 000 rpm		
Spindle type	KGT ²⁾ 20x5	KGT ²⁾ 20x5	KGT ²⁾ 20x5
Max. continuous feed force⁴⁾ N	1 200	2 200	2 200
Peak feed force N	5 300	8 000	8 000
Stroke lengths mm	70 / 100 / 150 / 200 / 300 / 400 / 600		
Max. speed mm/s	375	375	375

Electrical data				
Type	CMSB63S		CMSB63M	
Max. torque Nm	11.1		11.1 ¹⁾	
Standstill torque Nm	2.9		5.3	
Mechanical data				
Rated speed n_N	3 000 rpm 4 500 rpm 6 000 rpm			
Spindle type	KGT ²⁾ 25x6	PGT ³⁾ 20x5	KGT ²⁾ 25x6	PGT ³⁾ 20x5
Max. continuous feed force ⁴⁾ N	2 400	2 800	4 100	5 200
Peak feed force N	10 000		10 000	
Stroke lengths mm	60 / 100 / 160 / 180 / 200 / 400 / 600	100 / 200	60 / 100 / 160 / 180 / 200 / 400 / 600	100 / 200
Max. speed mm/s	450	375	450	375

Electrical data			
Type	CMSB71S	CMSB71M	CMSB71L
Max. torque Nm	19.2	25 ⁴⁾	25 ⁴⁾
Standstill torque Nm	6.4	9.4	13.1
Mechanical data			
Rated speed n_N	2 000 rpm 3 000 rpm 4 500 rpm 6 000 rpm		
Spindle type	KGT ²⁾ 32x6	KGT ²⁾ 32x6	KGT ²⁾ 32x6
Max. continuous feed force ⁴⁾ N	5 000	7 500	10 000
Peak feed force N	18 000	24 000	24 000
Stroke lengths mm	100 / 160 / 200 / 400 / 600 / 800 / 1 000 / 1 200		
Max. speed mm/s	450	450	450

¹⁾ Maximum permitted torque²⁾ Ball screw³⁾ Planetary roller screw⁴⁾ Depending on average travel speed

7.8 Linear motion

Modular CMSM.. electric cylinders



CMSMB50 – 71 series / ACH or ACA (axially serial)

Features

- Separately available modular unit (linear gear unit) with the proven oil bath lubrication of the CMSB.. standard electric cylinder series
- Can be combined with the standard servomotors from SEW-EURODRIVE (CMP50/63/71) using ACH/ACA adapters

Technical data

Type	NEW: CMSMB50 / ACH or ACA	CMSMB63 / ACH or ACA	CMSMB71 / ACH or ACA
Max. permitted input torque Nm	7	11.1	25
Max. permitted input speed rpm	4 500	4 500	4 500
Peak feed force N	8 000	10 000	24 000
Stroke lengths mm	70 / 100 / 150 / 200 / 300 / 400 / 600	60 / 100 / 160 / 180 / 200 / 400 / 600	100 / 160 / 200 / 400 / 600 / 800 / 1 000 / 1 200
Spindle type	KGT ¹⁾ 20x5	KGT ¹⁾ 25x6	KGT ¹⁾ 32x6

¹⁾ Ball screw



CMSMB50 – 71 series / AP (axially parallel)

Features

- Compact design
- Patented maintenance-free oil bath lubrication (lifetime lubrication)
- Very high thermal power density
- Very low-noise operation
- Optional water cooling
- Use of CMP50/63/71 standard servomotors

Electrical data

Type	NEW: CMSMB50/AP and		
	CMP50S	CMP50M	CMP50L
Max. torque Nm	5.2	7 ¹⁾	7 ¹⁾
Standstill torque Nm	1.3	2.4	3.3

Mechanical data

Rated speed n_n	3 000 rpm 4 500 rpm 6 000 rpm		
Spindle type	KGT ²⁾ 20x5		
Max. continuous feed force N	1 200	2 200	2 200
Peak feed force N	5 300	8 000	8 000
Stroke lengths mm	70 / 100 / 150 / 200 / 300 / 400 / 600		
Max. speed mm/s	375	375	375

¹⁾ Max. permitted torque

²⁾ Ball screw

7.8 Linear motion

Modular CMSM.. electric cylinders



CMSMB50 – 71 series / AP (axially parallel)

Electrical data

Type	CMSMB63/AP and		
	CMP63S	CMP63M	CMP63L
Max. torque Nm	11.1	11.1 ¹⁾	11.1 ¹⁾
Standstill torque Nm	2.9	5.3	7.1

Mechanical data

Rated speed n_N	3 000 rpm 4 500 rpm 6 000 rpm		
Spindle type	KGT ²⁾ 25x6		
Max. continuous feed force N	2 400	3 600	4 800
Peak feed force N	10 000	10 000	10 000
Stroke lengths mm	60 / 100 / 160 / 180 / 200 / 400 / 600		
Max. speed mm/s	450	450	450

¹⁾ Max. permitted torque

²⁾ Ball screw

Electrical data

Type	CMSMB70/AP and		
	CMP71S	CMP71M	CMP71L
Max. torque Nm	19.2	25 ¹⁾	25 ¹⁾
Standstill torque Nm	6.4	9.4	13.1

Mechanical data

Rated speed n_N	2 000 rpm 3 000 rpm 4 500 rpm 6 000 rpm		
Spindle type	KGT ²⁾ 32x6		
Max. continuous feed force N	5 000	7 500	10 000
Peak feed force N	18 000	24 000	24 000
Stroke lengths mm	100 / 160 / 200 / 400 / 600 / 800 / 1 000 / 1 200		
Max. speed mm/s	450	450	450

¹⁾ Max. permitted torque²⁾ Ball screw

7.9 Inverter technology

Control cabinet installation



MOVIDRIVE® B application inverters



Features	<ul style="list-style-type: none"> – Powerful drive inverter for dynamic applications with synchronous and asynchronous motors in the power range 0.55 to 315 kW – Great diversity of applications due to extensive expansion options with technology and communication options
Line connection	Power range kW
200 / 240 V / 3-phase	1.5 – 37
400 / 500 V / 3-phase	0.55 – 315
safetyDRIVE Functional safety	MOVISAFE®: Integrated functional safety Standard design Safe Torque Off (STO) PL d according to EN 13849-1
	For information on operating explosion-proof motors with our inverter technology, refer to page 119

Standard design	The units are equipped with IPOS ^{plus} ® integrated positioning and sequence control as standard and can be expanded by the options available. "00" at the end of the type designation indicates the standard design.
Technology version with application modules	<p>In addition to the standard version, these units include the technology functions "electronic cam" and "internal synchronous operation". The application version is indicated by "OT" following the type designation.</p> <p>The application version units also provide access to the application modules, the standardized control programs to solve sophisticated technical drive tasks, such as synchronized applications, positioning, flying saw, and winding.</p> <p>Advantages of the application module</p> <ul style="list-style-type: none"> – High functionality and user-friendly operator interface – Only parameters needed for the application have to be entered – Guided parameterization instead of complicated programming – No lengthy training, therefore quick project planning and startup – Control of all motion functions is performed directly in MOVIDRIVE® – Decentralized concepts can be implemented more easily

7.9 Inverter technology

Control cabinet installation

Type designation	Options for MOVIDRIVE® B
Keypad DBG60B	Standard keypad for parameterization, data management, startup, and diagnostics
Encoder interfaces DEH11B	<ul style="list-style-type: none"> – Motor encoder connection: TTL, RS422, Sin/Cos and HIPERFACE® encoders – Distance encoder connection: TTL, RS422, Sin/Cos and HIPERFACE® encoders
DER11B	<ul style="list-style-type: none"> – Motor encoder connection: Resolver – Distance encoder connection: TTL, RS422, Sin/Cos and HIPERFACE® encoders
DEH21B	<ul style="list-style-type: none"> – Motor encoder connection: TTL, RS422, Sin/Cos and HIPERFACE® encoders – Distance encoder connection: SSI absolute encoder
DEU21B	<ul style="list-style-type: none"> – Motor encoder connection: TTL, HTL, RS422, Sin/Cos, HIPERFACE®, SSI, CAN, EnDat 2.1 encoders – Synchronous encoder connection: TTL, HTL, RS422, Sin/Cos, HIPERFACE®, SSI, CAN, EnDat 2.1 encoders
DIP11A	<ul style="list-style-type: none"> – Motor encoder connection: TTL, RS422, Sin/Cos and HIPERFACE® encoders – Distance encoder connection: SSI absolute encoders
DIP11B	<ul style="list-style-type: none"> – Distance encoder connection: SSI absolute encoder – Expansion of digital inputs and outputs: 8x inputs, 8x outputs
Fieldbus connection <ul style="list-style-type: none"> – DFE32B / DFE33B – DFE24B – DFP21B – DFC11B / DFD11B – DFI11B / DFI21B – DFS11B / DFS21B 	<ul style="list-style-type: none"> – PROFINET IO / Modbus TCP + EtherNet/IP™ – EtherCAT® – PROFIBUS DPV1 – CANopen / DeviceNet™ – INTERBUS / INTERBUS-FOC – PROFIsafe via PROFIBUS / PROFIsafe via PROFINET
MOVISAFE® safety monitor <ul style="list-style-type: none"> – DCS31B – DCS21B + DFS12B – DCS21B + DFS22B 	<p>Safe movement/position monitoring, safe inputs and outputs up to PL e according to EN ISO 13849-1 and</p> <ul style="list-style-type: none"> – for “safe motion/position monitoring” – for “safe movement/position monitoring and communication” (PROFIsafe/PROFIBUS) – for “safe movement/position monitoring and communication” (PROFIsafe/PROFINET)
Expansion for inputs and outputs <ul style="list-style-type: none"> – DIO11B 	8 x digital inputs and 8 x digital outputs; 1 x analog differentiation; 2 x analog outputs
MOVI-PLC® controller <ul style="list-style-type: none"> – DHE21B/DHE41B – DHF21B/DHF41B – DHR21B/DHR41B – External option: UHX71B 	<ul style="list-style-type: none"> – MOVI-PLC® advanced, Ethernet interface – MOVI-PLC® advanced, Ethernet / PROFIBUS / DeviceNet™ interface – MOVIPLC® advanced, Ethernet / PROFINET / Modbus TCP / EtherNet/IP™ interface – Compact controller: <ul style="list-style-type: none"> - MOVI-PLC® power: IEC-61131-3 programmable motion and logic controller or - CCU power: parameterizable application controller
Other <ul style="list-style-type: none"> – DRS11B – USB11A – UWS21B 	<ul style="list-style-type: none"> – Synchronous operation card – Interface adapter for connection to a PC via USB interface – Interface adapter for connection to a PC via RS232 interface

Engineering software MOVITOOLS® MotionStudio	The MOVITOOLS® MotionStudio program package allows you to conveniently start up, configure and run diagnostics for MOVITRAC® B frequency inverters and MOVIDRIVE® B application inverters.
Regenerative power supply MOVIDRIVE® MDR60A 15 kW – 160 kW MOVIDRIVE® MDR61B 160 kW – 315 kW	The regenerative power supply can supply multiple units with power using a central line connection. In regenerative mode, the power is fed back into the supply system. Using the MDR60A/MDR61B lets you save power and installation costs.
Braking resistors Type BW	BW series braking resistors are available for regenerative operation of MOVITRAC® B frequency inverters and MOVIDRIVE® B drive inverters. Using an integrated temperature sensor, the resistor can be protected without external monitoring.
Line choke type ND	ND series line chokes increase the overvoltage protection of inverters. This is an important characteristic in rough industrial power supply systems, especially if the inverter is installed near a supply transformer.
Line filter type NF	The NF line filter series is available for EMC-compliant installation according to EN 61800-3. They suppress interference emission on the line side of inverters. These line filters ensure that limit value class C1 is maintained on the supply end.
Output choke type HD	HD series output chokes suppress interference emission emitted from unshielded motor cables. They enable the motor to meet limit value class C1 requirements in accordance with EN 61800-3 in EMC-compliant installations. Output chokes provide an alternative to shielded motor cables in EMC-compliant installations.
Output filter type HF	HF series output filters are sine filters that smooth out the output voltage of inverters. Output filters are used for group drives to suppress discharge currents in motor cables and for long motor cables to prevent voltage peaks.

7.9 Inverter technology

Control cabinet installation



MOVIDRIVE® MDR regenerative power supply units



Can be used with product series	<ul style="list-style-type: none"> – MOVIDRIVE® B: 0.55 – 315 kW – MOVITRAC® MC07B: 5.5 – 75 kW
Features	<p>Energy balance</p> <p>Braking energy from the load cycle is no longer converted into heat energy but is fed back into the grid.</p> <p>Energy recovery is particularly interesting for applications with a high energy potential of lowering/ deceleration movements of the load cycle, such as gantry cranes, storage/retrieval systems or lifting/lowering applications.</p>
Regenerative power supply: For central energy supply and recovery	<ul style="list-style-type: none"> – Used for central energy supply and recovery to supply the connected inverters with energy – Several MOVIDRIVE® B inverters are connected in a DC link system – Energy is exchanged between the drive axes and excess braking energy is fed back into the power supply system
Regenerative power supply: Function as a brake module (only MDR60A0150)	<ul style="list-style-type: none"> – Using the regenerative power supply unit as brake module means the connected inverters are not supplied with energy but only the braking energy is fed back into the power supply system – DC link supplied via the integrated input rectifier on the drive axis – Braking energy released during the application is fed back into the power supply system – The regenerative power supply unit is selected based on the braking energy released during the application, drive inverters are selected based on the motor load → cost-optimized overall system – Example: <ul style="list-style-type: none"> - Power rating of drive inverters: 30 kW - Power rating of regenerative power supply unit: 15 kW
Advantages	<ul style="list-style-type: none"> – Reduced overall energy consumption – Reduced CO₂ emissions – Reduced energy costs – Cost-efficient installation – No investment in braking resistors – No braking resistors need to be installed outside the control cabinet – No heating of the environment or of the control cabinet through braking resistors – Saves control cabinet space and expenditure for ventilation

Technical data

MOVIDRIVE® type MDR..	Connection voltage V	Power range kW	Line current I_N A	Overload capacity
MDR60A0150-503-00 Size 2	3x AC 380 V– 500 V	15	– 15 As a centralized supply and regenerative power supply unit – 22 As a brake module	– 150% for 60 s As a centralized supply and regenerative power supply unit – 37 kW for 50 s As a brake module peak braking power
MDR60A0370-503-00 Size 3		37	66	150% for 60 s
MDR60A0750-503-00 Size 4		75	117	150% for 60 s
MDR60A1320-503-00 Size 6		132 – 160	260 (at 160 kW)	150% for 60 s max. continuous power 125%
MDR61B1600-503-00 Size 7		160 – 315	250	
MDR61B2500-503-00 Size 7			400	

7.9 Inverter technology

Control cabinet installation



Regenerative power supply and motor inverter

MOVIDRIVE® MDR61B up to 315 kW



Features	<ul style="list-style-type: none"> – Energy-efficient and optimized overall concept: MOVIDRIVE® B product series extended by regenerative power supply units and corresponding motor inverters in the power range from 160 to 315 kW – Particular interesting for applications with potential energy, such as in hoists, cranes and gantries, or in trolleys with high kinetic energy produced through electrical braking
Functions	<ul style="list-style-type: none"> – Used as central regenerative power supply for connected standard inverters or motor inverters – Energy is fed back into the grid when the application is operating as a generator, e.g. during electrical braking – Braking energy is no longer converted into heat but is fed back into the grid for further use
Advantages	<ul style="list-style-type: none"> – Significant reduction of the overall energy consumption / of CO₂ emissions / of energy costs – No braking resistors are required <ul style="list-style-type: none"> - No investment costs for braking resistors - No installation effort for external braking resistors - No heating up of the environment through braking resistors – Sinusoidal line current = controlled energy recovery – With coated printed-circuit boards as standard for demanding ambient conditions – Simple installation and wiring: integrated PWM filter / integrated choke / integrated and automatic DC link precharge / integrated line contactor – Modular power section, which means not the entire unit needs to be replaced in the event of service – EMC limit value class C3 (EN 61800-3) with the standard unit <ul style="list-style-type: none"> - On supply system end: without any measures → no external line filter necessary - On motor end: with shielded motor cables and output choke

Type designation	MDR61B1600-503-00/L	MDR61B2500-503-00/L
Connection voltage	3x AC 380 V – 500 V	
Nominal power kW	160	250
Line current/nominal motor power I_N A	250	400
Maximum continuous power	125% I_N	
Overload capacity	150% I_N for 60 s	
External accessories for control cabinet installation	<ul style="list-style-type: none"> – Mounting base – Air duct – Connection kit – Touch guard (IP20 kit) – DC link coupling 	

7.9 Inverter technology

Control cabinet installation



MOVIAxis® multi-axis servo inverter



Features	<ul style="list-style-type: none"> – Multi-axis servo system for highly dynamic applications up to 250 A motor current – Power supply and regenerative power supply up to 187 kW – DC link power supply for DC 24 V – Capacitor and buffer module – Connection of all common motor and distance encoders – Fieldbus interfaces, fieldbus gateways and clock-synchronized interfaces – Scaled motion and logic controller directly at the axis system, speed control, positioning, motion control and kinematics – Wide range of accessories: Cables, braking resistors, line filters, line chokes, brake control units
-----------------	--

Power supply module type

Line connection V	3x AC 380 – 500
Nominal power kW	10, 25, 50, 75 kW at 250% for 1 s

Block-shaped power supply and regenerative power supply module

Line connection V	3x AC 380 – 500
Nominal power kW	50, 75 at 250% for 1 s

Sinusoidal power supply and regenerative power supply module

Line connection V	3x AC 380 – 480
Nominal power kW	50, 75 at 200% for 1 s

DC link power supply unit	
Supply	Directly from DC link
Nominal power	3 x 10 A, limited to 600 W total power

Axis modules

Output current A at 8 kHz	2, 4, 8, 12, 16, 24, 32, 48, 64, 100 at 250 % for 1 s
Communication interfaces	PROFIBUS, EtherCAT®
Encoder interfaces motor encoder	
Encoder interfaces distance encoder	
safetyDRIVE Functional safety	<ul style="list-style-type: none"> – MXA80: without integrated functional safety – MXA81: Safe Torque Off (STO) up to cat. 3 according to EN 954-1 and PL d to EN ISO 13849-1 – MXA82: Safe Torque Off (STO) up to cat. 4 according to EN 954-1 and PL e to EN ISO 13849-1 – Optional MOVISAFE® UCS..B safety module: Drive safety functions (SLS, SDI, SLP, etc.) according to EN 61800-5-2

Master module

Communication gateway	DeviceNet™, PROFIBUS, PROFINET, EtherNet/IP™, Modbus TCP
Data management	Via memory card, automatic data set download when replacing the axis module
Integrated motion controller	Programmable in IEC 61131, parameterizable functionalities

7.9 Inverter technology

Accessories and options for MOVIAXIS®

Encoder and distance encoder card XGH11A	<ul style="list-style-type: none"> – Multi-encoder card for motor and distance encoder Hiperface®, Endat 2.1, Sin/Cos – Incremental encoder simulation – ± 10 V analog input – DC 24 V supply
Encoder and distance encoder card XGS11A	<ul style="list-style-type: none"> – Like XGH11A, additional for SSI encoders
Input/output card XIA11A	<ul style="list-style-type: none"> – 4 DI, 4 DO – 2 AI, 2 AO, 12-bit resolution – DC 24 V supply
Input/output card XIO11A	<ul style="list-style-type: none"> – 8 DI, 8 DO – DC 24 V supply
Communication interface XF011A	PROFIBUS IO fieldbus interface, up to 12 MBaud
Communication interface XFE11A	Fieldbus interface for connection to EtherCAT® networks
Communication interface XSE11A	System bus option card for expansion to EtherCAT®-compatible system bus SBus ^{plus}
MOVI-PLC® controller – DHE21B/DHE41B – DHF21B/DHF41B – DHR21B/DHR41B	<ul style="list-style-type: none"> – MOVI-PLC® advanced, ETHERNET interface – MOVI-PLC® advanced, ETHERNET / PROFIBUS / DeviceNet™ interface – MOVI-PLC® advanced, ETHERNET / PROFINET / Modbus TCP / EtherNet/IP™ interface <p>Compact controller:</p> <ul style="list-style-type: none"> – MOVI-PLC® power: IEC-61131-3 programmable motion and logic controller or – CCU power: parameterizable application controller
Engineering software MOVITOOLS® MotionStudio	The MOVITOOLS® MotionStudio program package allows you to conveniently start up, configure and diagnose the MOVIAXIS® multi-axis system.
Braking resistors Type BW	BW series braking resistors are available for the regenerative operation of the MOVIAXIS® multi-axis system. Using an integrated temperature sensor, the resistor can be protected without external monitoring.
Line choke type ND	ND series line chokes increase the overvoltage protection of the MOVIAXIS® multi-axis system. This is an important characteristic in rough industrial power supply systems, especially if the inverter is installed near a supply transformer.
Line filter type NF	The NF line filter series is available for EMC-compliant installation according to EN 61800-3. They suppress interference emission on the line side of inverters. These line filters ensure that limit value class C1 is maintained on the supply end.

effiDRIVE® – Energy efficiency in servo applications



Features

The crucial part of energy efficient operation of servo drive technology is the detailed planning and fulfilment of process and efficiency requirements. With the energy efficiency concept effiDRIVE® for servo applications, SEW-EURODRIVE offers comprehensive consulting during the planning of new plants and the modernization of existing systems. With our great expertise regarding drive technology and the industry, we focus on efficiency already during the first steps of selecting the used technology and products in order to optimize the energy consumption. But it is not sufficient to only combine energy efficient components. Only looking at the application in its entirety allows for the maximum energy efficiency.

Energy-efficient components

Sine-shaped regenerative power supply modules MXR80A

- In regenerative operating states, the braking energy is fed back into the supply system.
- Energy supply and energy recovery are sinusoidal with $\cos \phi = 1$
- Almost complete avoidance of supply harmonics
- No interference of sensitive electronic devices in direct vicinity
- Determination of energy flow, detailed diagnostic information
- Controlled DC link voltage independent of link voltage

Block-shaped regenerative power supply modules MXR81A

- In regenerative operating states, the braking energy is fed back into the supply system
- Inexpensive alternative to sinusoidal regenerative power supply if the supply system conditions are stable
- Automatic deactivation of the recovery during motoring operation
- Emergency braking resistor can be connected

MXC80A capacitor module

- DC link energy is absorbed or supplied with up to 50 kW
- Up to 1000 Ws can be stored in the module
- The charging of the module is actively via charging connection
- With adequate project planning, the braking energy can be completely recycled for the next travel order
- There is no need for braking resistors
- It is especially suited for cycles with small drives

MXP81A compact power supply module

- Combination of 10 kW power supply module and 250 Ws capacitor module
- Especially cost-effective and space-saving with small systems
- Size-optimized braking resistor is already integrated in the module

7.9 Inverter technology

NEW: Decentralized servo inverter



MOVIAxis® MMD60B

Features

- Powerful, compact performance
- High overload capacity of up to 400%
- Available as decentralized variant installed close to the motor, or with the inverter integrated in the motor
- Fully scalable when installed close to the motor, with CM..., CMP... and CMPZ... with all options
- Reduced wiring work
- Direct, decentralized control of 24 V brakes possible
- Saves control cabinet space
- With EtherCAT®-compatible SBUS^{PLUS} for very extensive plants

Decentralized inverter

Designation	Maximum output current (A)
MMD60B019-5A3-4-00	19.0
MMD60B024-5A3-4-00	24.0
MMD60B036-5A3-4-00	36.0

Drive with integrated inverter

Motor	MOVIAxis® MMD60B designation		
	019	024	036
CM71L, $n_n = 4\ 500$ rpm	-	X	X
CM90L, $n_n = 4\ 500$ rpm	-	-	X
CM112L, $n_n = 1\ 200$ rpm	-	-	X
Decentralized frequency inverter for mounting close to the motor	X	X	X

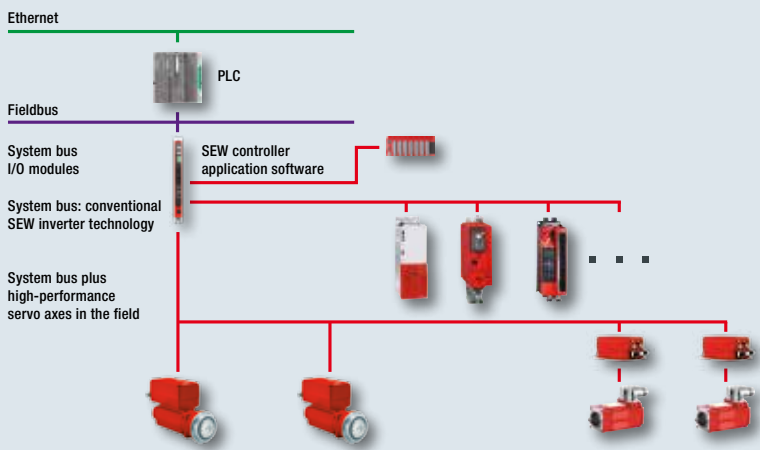

Automation concept for system and machine modules

Accessories and options: Software



MOVITOOLS® MotionStudio engineering software

Features

- Modular software concept for consistent engineering: Startup, control, diagnostics, communication, and visualization
- For parameterizing, programming, and diagnosing most inverter series of SEW-EURODRIVE – independent of the device



MOVIVISION® plant software

Features

- Intuitive software solution for system manufacturers and operators
- Simple and fast startup of a drive system
- Can be used at any time and any place
- No special programming knowledge is required – only parameters have to be entered

→ More information regarding software: Pages 298 – 301

08

INDUSTRIAL COMMUNICATION

8.1 Industrial ETHERNET	270
8.2 Conventional fieldbuses	273
8.3 SEW system buses	275
8.4 Communication modules and fieldbus tools	277
8.5 Safe communication	278



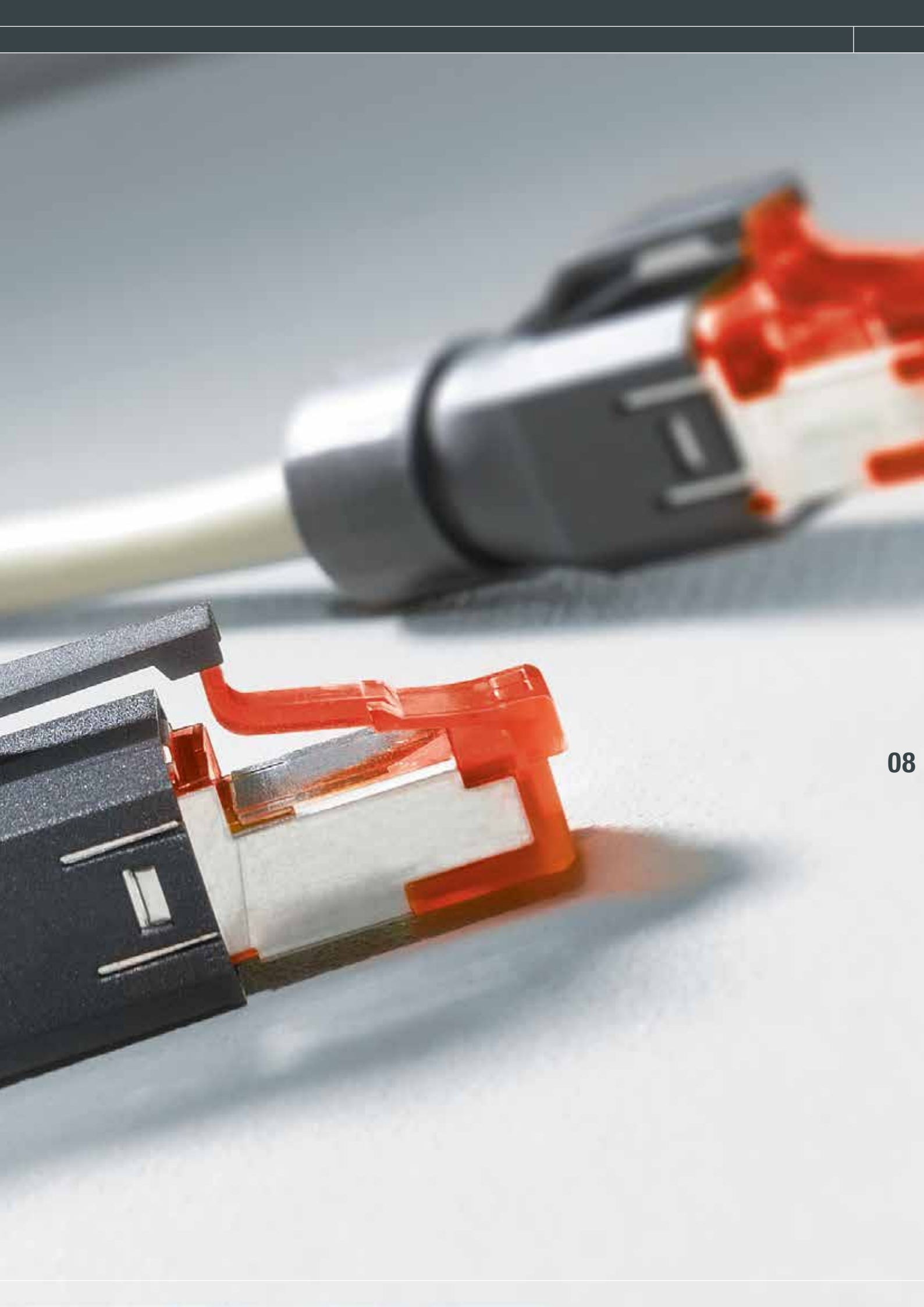

8.1 Industrial Ethernet

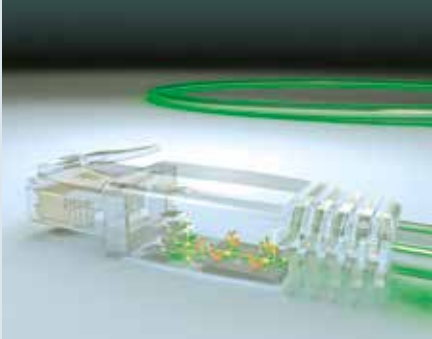

Industrial ETHERNET

One cable – numerous possibilities

- High transmission rate
- Widespread medium
- Enables the use of IT technology, such as e-mail for notification if an error occurs, and diagnostics for the implemented components using the Internet Explorer
- Ensures vertical data communication with the control level with high bandwidth as well as horizontal process data communication between controller and application (e.g. drive inverters)
- Comprehensive service from SEW-EURODRIVE for process data communication

Advantages

- Vertical and horizontal communication using Industrial ETHERNET
- Real-time capable process data communication between controller and drive engineering components (soft real time) with 10 process data words (each direction)
- Fast data transfer with 100 Mbit/s
- Diagnostics of drive technology via Internet Explorer, for example
- Programming and diagnostics for the drive technology can be carried out via Ethernet, which makes remote maintenance easy to handle
- Broadband data communication between the control level and field level
- Control and engineering combined in one bus system, saving costs for installation and maintenance
- Fast system integration

Functions

- Process data communication by means of protocol, either PROFINET IO/RT, EtherNet/IP™, Modbus TCP or EtherCAT®, for simple and fast data exchange between the control and field levels
- Control and diagnostics via Ethernet – local operation, diagnostics, and maintenance at the field level
- Integrated web server (not EtherCAT®) to diagnose the drive technology via Internet Explorer
- Central data backup at control level
- Parameter setting and programming using MOVITOOLS® MotionStudio via Ethernet
- Reduction of installation costs and maintenance due to installation of only one diagnostic bus or engineering bus system

Overview of fieldbus options

Industrial ETHERNET	PROFINET® 	EtherNet/IP™ 	Modbus TCP 	EtherCAT® 
----------------------------	---	--	---	---

Inverter technology: Control cabinet installation and wall mounting

MOVITRAC® LTE basic inverter	DFE32B/UOH option	DFE33B/UOH option	DFE33B/UOH option	DFE24B/UOH option
MOVITRAC® LTP standard inverter	Options – DFE32B/UOH – Controller DHR – LTFE33A (in preparation)	Options – DFE33B/UOH – Controller DHR – LTFE33A (in preparation)	Options – DFE33B/UOH – Controller DHR – LTFE31A (in preparation)	Options – DFE24B/UOH – LTFE24A (in preparation)

Inverter technology: Control cabinet installation

MOVITRAC® B standard inverter	Options – DFE32B – DFE32B/UOH – DFS21B/PROFIsafe	Options – DFE33B – DFE33B/UOH	Options – DFE33B – DFE33B/UOH	Options – FSE24B – DFE24B – DFE24B/UOH
MOVIDRIVE® B application inverter	Options – DFE32B – DFS21B/PROFIsafe	DFE33B option	DFE33B option	DFE24B option
MOVIAXIS® multi-axis servo inverter	Options – UFR41B – Controller DHR	Options – UFR41B – Controller DHR	Options – UFR41B – Controller DHR	XFE24A option

8.1 Industrial Ethernet

Overview of fieldbus options

Industrial ETHERNET	PROFINET® 	EtherNet/IP™ 	Modbus TCP 	EtherCAT® 
----------------------------	---	--	---	---

Decentralized inverters

MOVIMOT® standard inverter	Options – MFE52A – optional MOVIFIT® MTM PROFIsafe	MOVIMOT® MTM option	MOVIMOT® MTM option	MFE72A option
– MOVIFIT® SC motor starter – MOVIFIT® MC distributor for MOVIMOT® – MOVIFIT® FC standard inverter	On-board interface PROFIsafe optional	On-board interface	On-board interface	
MOVIPRO® standard inverter	On-board interface PROFIsafe optional	On-board interface	On-board interface	





Decentralized drives / mechatronics

Gearmotor with integrated MOVIMOT® inverter	Options – MFE52A – optional MOVIFIT® MTM PROFIsafe	MOVIMOT® MTM option	MOVIMOT® MTM option	MFE72A option
MOVIGEAR® SNI and DRC...SNI electronic motor	On-board interface in MOVIFIT® FDC	On-board interface in MOVIFIT® FDC	On-board interface in MOVIFIT® FDC	
MOVIGEAR® DSC and DRC...DSC electronic motor	Options – DFE32B/UOH – DFS21B/PROFIsafe	DFE32B/UOH option	DFE32B/UOH option	DFE24B/UOH option
Fieldbus gateway	Options – UFR41B – DFE32B/UOH	Options – UFR41B – DFE33B/UOH	Options – UFR41B – DFE33B/UOH	DFE24B/UOH option
Controller MOVI-PLC® and CCU (Configurable Control Unit) as well as MOVIFIT® FDC	On-board interface DHR	On-board interface DHR	On-board interface DHR	

8.2 Conventional fieldbuses

Features	<ul style="list-style-type: none"> – Smooth communication on all levels of the system structure – Basis for efficient, flexible automation concepts, allow for economic startups and smooth production processes – Global standard as conventional fieldbuses are used worldwide
-----------------	---

Overview of fieldbus options

Conventional fieldbuses	PROFIBUS® 	INTERBUS 	DeviceNet™ 	CANopen 	AS-Interface 
--------------------------------	---	--	--	---	--

Inverter technology: Control cabinet installation and wall mounting



MOVITRAC® LTE simple inverter	Option DFP21B/UOH	UFI11A option	DFD11B/UOH option	UF011A option	
MOVITRAC® LTP standard inverter	Options – DFP21B/UOH – Controller DHF	UFI11A option	Options – DFD11B/UOH – Controller DHF	UF011A option	

Inverter technology: Control cabinet installation

MOVITRAC® B standard inverter	Options – DFP21B – DP21B/UOH – DFS11B/PROFIsafe	UFI11A option	Options – DFD11B – DFD11B/UOH	On-board interface	
MOVIDRIVE® B application inverter	Options – DFP21B – DFS11B/PROFIsafe	DFD11B/21B option	DFD11B option	On-board interface	
MOVIAXIS® multi-axis servo inverter	Options – XP11A – UFF41B – DHF controller		Options – XP11A – DHF controller		

8.2 Conventional fieldbuses

Overview of fieldbus options

Conventional fieldbuses	PROFIBUS® 	INTERBUS 	DeviceNet™ DeviceNet	CANopen CANopen	AS-Interface 
--------------------------------	---	--	---------------------------------------	----------------------------------	--

Decentralized inverters

MOVIMOT® standard inverter	MFP/MQP option	MFI option	Options – MDF/MQD – MOVIMOT® MTM		On-board interface
– MOVIFIT® SC motor starter – MOVIFIT® MC distributor for MOVIMOT® – MOVIFIT® FC standard inverter	On-board interface, PROFIsafe optional		On-board interface		On-board interface in MOVIFIT® basic
MOVIPRO® standard inverter	On-board interface, PROFIsafe optional		On-board interface		

Decentralized drives / mechatronics

Gearmotor with integrated MOVIMOT® inverter	MFP/MQP option	MFI option	Options – MDF/MQD – MOVIMOT® MTM		On-board interface
MOVIGEAR® SNI and DRC...SNI electronic motor	Options – UFF41B/OMG42 – on board Interface in MOVIFIT® FDC		Options – UFF41B/OMG42 – on board Interface in MOVIFIT® FDC		
MOVIGEAR® DSC and DRC...DSC electronic motor	Options – DFP21B – DFS11B/PROFIsafe	UFI11A option	DFD11B/UOH option	UF011A option	On-board interface
Fieldbus gateway	Options – UFF41B – DFP21B/UOH	UFI11A option	Options – UFF41B – DFD21B/UOH	UF011A option	
Controller MOVI-PLC® and CCU (Configurable Control Unit) as well as MOVIFIT® FDC	On-board interface DHP/DHF		On-board interface DHF		

8.3 SEW system buses

Features	<ul style="list-style-type: none"> – SEW system bus technologies especially designed for control and drive technology from SEW-EURODRIVE: Can be used in centralized and decentralized system concepts – SEW system buses are perfectly designed and preset for drive electronics and controllers: <ul style="list-style-type: none"> - Reduced installation work as interfaces are avoided or completely integrated - Fast data exchange - Integrated diagnostics concept
Technologies	<p>SNI (Single Line Network Installation) combines the advantages of reduced installation work with the technology of Ethernet-based communication in one innovative drive infrastructure solution:</p> <ul style="list-style-type: none"> – Use of the electrical energy infrastructure as basis for the transmission of Ethernet-based communication signals – Ethernet-based access to all individual stations from a central point – Significant reduction in installation times as only supply cables need to be connected – Maximum expansion of the line topology for up to 10 drives with a total of 100 m cable length – Installation with shielded standard cables according to the SEW-EURODRIVE regulations; No special cables are necessary <hr/> <p>SBus (CAN-based SEW system bus) The CAN technology was developed for mobile applications and is also used in automation applications:</p> <ul style="list-style-type: none"> – Consistent use of the multi-master functionality of the CAN for data exchange between the drives; In some projects without any additional controller possible – The SBus allows for applications that require hard real-time conditions for the communication. The clock-synchronous transmission of setpoint and actual values between the drives or within the network with a controller makes for applications such as “Electronic gear unit” and “multi-axis MotionControl” – Inexpensive networking due to use of standard CAN bus cables, in the control cabinet with separable screw connection, in decentralized solutions with the M12 plug connectors standardized for DeviceNet™ or CANopen – Maximum expansion of the line topology up to 500 m. The number of drives and peripheral components is limited to 64, but is usually less than 20. <hr/> <p>SBUS^{PLUS} (EtherCAT®) In addition to the ideal integration, SBUS^{PLUS} offers additional functions in networks with our controllers and drive technology that allow for an easy and simple startup:</p> <ul style="list-style-type: none"> – EtherCAT® is a hard real time-capable communication technology that can be flexibly installed – Star, tree and line topologies can be implemented with stub lines nearly without any performance losses – For further information refer to ETG (EtherCAT Technology Group) http://www.ethercat.org

8.3 SEW system buses

Overview of SEW system buses

Unit series	Decentralized controller MOVIFIT® FDC-SNI variant		DHx21 control card		DHx41 control card		UHX71B control card power		
	Software CCU: parame- terizable solutions	Software MOVI-PLC®: free pro- gramming	Software CCU: parame- terizable solutions	Software MOVI-PLC®: free pro- gramming	Software CCU: parame- terizable solutions	Software MOVI-PLC®: free programming	Software MOVI-PLC®: free programming		
System bus	SBus (CAN) and SNI		SBus (CAN)			SBus (CAN)	SBUS ^{PLUS} (EtherCAT®)	SBUS ^{PLUS}	SBus on OSC71B

Control cabinet

MOVITRAC® B			via FSC	via FSC	via FSC	Yes	via FSE24B	via FSE24B	FSC
MOVIDRIVE® B			Yes	Yes	Yes	Yes	via DFE24B	via DFE24B	–
MOVITRAC® LTX			Yes	Yes	Yes	Yes			Yes
MOVIAXIS®			–	–	Yes	Yes	via XFE/XSE	via XFE/XSE	–

Control cabinet and decentralized installation

MOVITRAC® LTE-B	Yes ¹⁾	Yes	Yes ¹⁾	Yes	Yes ¹⁾	Yes		–	Yes
MOVITRAC® LTP-B	Yes ¹⁾	Yes	Yes ¹⁾	Yes	Yes ¹⁾	Yes		–	Yes

Decentralized drives / mechatronics

MOVIGEAR® SNI	Yes	Yes	–	–	–	–	–	–	–
MOVIGEAR® DSC	Yes	Yes	Yes	Yes	Yes	Yes		–	Yes
MOVIFIT® Slave	Yes	Yes	–	Yes	–	Yes		–	–
MOVIAXIS® MD	–	–	–	–	–	–	Yes	–	–

Accessories

I/O system	–	via OCC	–	via OCC	–	via OCC	via OCE	via OCE	–
------------	---	---------	---	---------	---	---------	---------	---------	---

¹⁾ only 3PD speed control

8.4 Communication modules and fieldbus tools

Features	Simplify communication between control and drive components and establishing communication structures.
Communication modules	Are offered in several technology program packages. This example of SEW-EURODRIVE is a free of charge, non-binding service and shows the basic procedure for creating a PLC program. SEW-EURODRIVE is not liable for the content of the sample program.
Fieldbus tools	Do not hesitate to contact us: We will be happy to provide easy Ethernet master for the process and parameter exchange <ul style="list-style-type: none">– from Windows PCs with Ethernet interface– to units from SEW-EURODRIVE with EtherNet/IP™ or MODBUS TCP interface using the fieldbus tools.

8.5 Safe communication



Certified to (IEC 61508) SIL 3, (EN ISO 13489-1) PL e

The safety functions Safe Torque Off (STO) and Safe Stop (SS1) according to IEC 61800-5-2 can be activated for **MOVIDRIVE® B** application inverters and **MOVITRAC® B** standard inverters via the following options.

- MOVISAFE® DFS11B for connecting MOVIDRIVE® B / MOVITRAC® B: PROFIsafe on PROFIBUS DP
- MOVISAFE® DFS21B for connecting MOVIDRIVE® B / MOVITRAC® B: PROFIsafe on PROFINET IO

These components come equipped with a safety-related output used for the safe disconnection of individual MOVIDRIVE® B / MOVITRAC® B inverters or a group of MOVIDRIVE® B / MOVITRAC® B inverters.

MOVIMOT® gearmotors with integrated inverter can be controlled using PROFIBUS/PROFIsafe when the gearmotors are used together with MQS../Z.6F field distributors.

Field distributors with integrated MOVIMOT® inverter of the MQS../Z.7F and MQS../Z.8F type are also equipped with a PROFIBUS/PROFIsafe interface.

The decentralized **MOVIFIT®** drive controller can also be controlled via PROFIsafe in connection with MOVIFIT® MC or FC with MOVISAFE® S12 safety option. The MOVISAFE® S12 safety option, certified to IEC 61800-5-2, is an integrated and parameterizable option card with safe inputs and outputs (F-DI, F-DO) that can also evaluate safety-related motor encoders. These functions allow you to connect safety technology sensors for disconnection purposes and monitoring functions for speed and direction of rotation.

Control cabinet drive technology: Functional safety integrated in the inverter

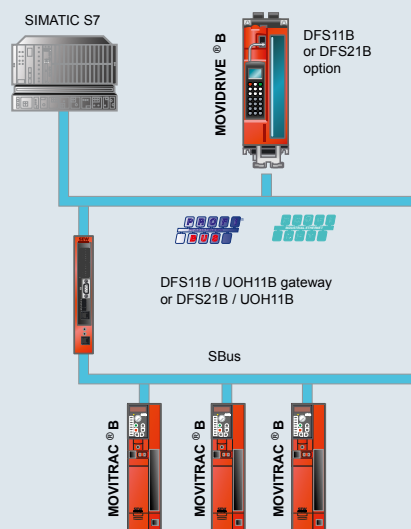

Decentralized installation

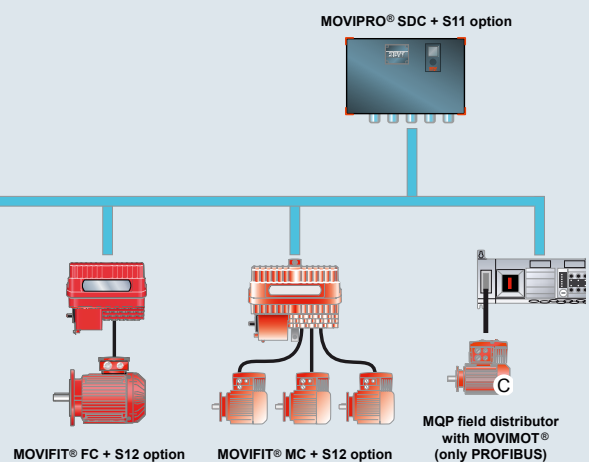

Certified to (IEC 61508) SIL 3, (EN ISO 13489-1) PL e

- Additional safe motion functions according to IEC 61800-5-2 can be implemented for **MOVIDRIVE® B** application inverters from size 1. These functions are SS1, SS2, SOS, SDI, SLS, SSR, SLA, SAR, SSM, SLI, SCA, and SLP. Combining the **MOVISAFE®** DCS21B option card with the DFS12B (PROFIBUS) or DFS22B (PROFINET IO) fieldbus interface enables control via PROFIsafe.
- The UCS..B safety module has all the safety functions for monitoring the movements of **MOVIAXIS®** multi-axis servo inverters. Safe data is exchanged with the controller via PROFIsafe.

The modular **MOVIPRO®** concept comprises the following safety options:

- Control via PROFIsafe with **MOVISAFE®** S11 option
- The integrated **MOVISAFE®** S11 option comes equipped with 4 safety-related inputs for connecting safe sensors and two safety-related outputs
- Optional, safety-related brake disconnection (SBC)
- Decentralized **MOVISAFE®** HM31 safety controller for independent, safety-relevant control of application solutions, with integrated safe master-slave communication

08

Control cabinet drive technology: Modular safety in the inverter

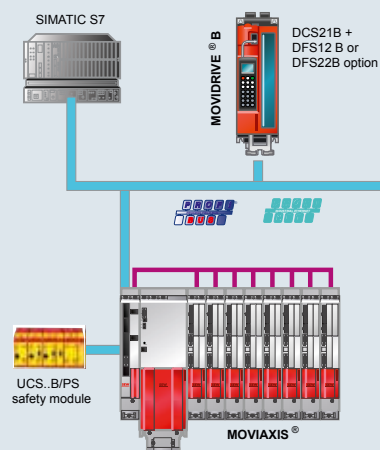

Decentralized installation

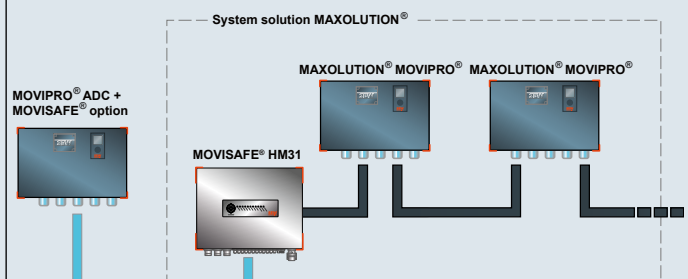

* MOVIPRO® ADC with MOVISAFE® HM31 option only in connection with MAXOLUTION® system solutions.

09 CONTROL TECHNOLOGY

9.1 Controller hardware

Decentralized controllers	
– MOVIFIT® MTx Technology variant	282
– MOVIFIT® FDC-SNI variant	283
– MOVIPRO® ADC variant	284
Control cabinet controllers	
– Controller performance class “standard”	285
– Controller performance class “advanced”	286
– Controller performance class “power”	287
Accessories and options	288

9.2 Controller software

Free programming MOVI-PLC®	290
Parameterizable solutions CCU	291





9.1 Controller hardware

Decentralized controllers



MOVIFIT® MTx Technology variant

Features

- MOVIFIT® function level Technology
- With integrated basic control card
- For decentralized field installations up to degree of protection IP69
- As freely programmable motion and logic controller MOVI-PLC® with libraries and program modules specifically for materials handling applications
- As parameterizable configurable control unit (CCU) with special application modules for materials handling applications, such as cam or simple positioning

Technical data

- PROFIBUS Slave DP-V1, PROFINET, EtherNet/IP™
- 2 CAN interfaces, 1 of which is electrically isolated
- 1 RS485 interface
- 8 digital I/Os (inputs/outputs)
- Status display for controller (programmable logic controller) and fieldbus



MOVIFIT® FDC-SNI variant

Features

- MOVIFIT® FDC-SNI with integrated control card available in standard and advanced performance class
- Module controller for up to 16 axes via SBus or max. 10 MOVIGEAR® SNI
- As freely programmable motion and logic controller MOVI-PLC® with libraries and program modules specifically for materials handling applications
- As a configurable control unit (CCU) with special application modules for materials handling such as rapid/creep speed positioning, bus positioning or universal module
- Motion and logic controller for response times > 10 ms
- Single-axis motion control libraries and program modules
- SD memory card for easy unit replacement and recipe management
- Fast engineering via USB and Ethernet

Technical data

- 1 x Ethernet (10/100 BaseT) for engineering or TCP/IP and UDP via IEC61131-3
- 1 x CAN, electrically isolated
- 1 x SNI
- 1 x RS485, electrically isolated
- USB interface
- PROFINET slave, EtherNet/IP™ slave, Modbus TCP/IP slave
- 12 digital inputs and 4 digital I/Os
- Status display of PLC and fieldbus
- Real-time clock
- 2 MB program memory, 6 MB data memory
- 32 kB retain variables, 24 kB system variables (retain)
- Free-running task (min. 10 ms), 1 cyclic task (10 – 10 000 ms)
- PC-readable memory card for firmware and application program

9.1 Controller hardware

Decentralized controllers



MOVIPRO® ADC variant

Features

- MOVIPRO® ADC with integrated control card advanced
- For compact performance with decentralized field installation up to IP54
- As a freely programmable motion and logic controller with libraries and program modules specifically for materials handling technology applications
- As a configurable control unit (CCU) with special application modules for materials handling and positioning applications, such as universal mode and rapid/creep speed positioning
- Motion and logic controller for very short response times
- Technology motion control libraries and program modules, such as electronic gear unit, electronic cam
- SD memory card for easy unit replacement
- Quick to engineer via USB and Ethernet

Technical data

- 1 x Ethernet interface (10/100 BaseT) for engineering tasks or TCP/IP and UDP via IEC 61131-3
- 1 x Ethernet as SBus^{PLUS} (EtherCAT®) master
- 1 x CAN interface, electrically isolated
- 1 x RS485 interface, electrically isolated
- PROFIBUS slave DP-V1, DeviceNet™ slave (DHF41B)
- PROFINET slave, EtherNet/IP™ slave, Modbus TCP/IP slave
- 12 digital inputs and 4 digital inputs/outputs
- Status display for PLC and fieldbus
- PC-readable memory card for firmware and application program

Controller for control cabinet installation



Controller performance class “standard”

DHx21B control card

Variants	<ul style="list-style-type: none"> – DHE21B version with Ethernet interface – DHF21B version with additional PROFIBUS and DeviceNet™ slave interface – DHR21B version with additional PROFINET/EtherNet/IP™/Modbus TCP/IP slave interface
Features	<ul style="list-style-type: none"> – Motion and logic controller for medium response times – MultiMotion Light motion operating system – Motion control for up to 16 axes via SBus – MOVI-PLC® I/O system via SBus – SD card for easy unit replacement and recipe management – Quick to engineer via USB and Ethernet
Technical data	<ul style="list-style-type: none"> – 1 x Ethernet interface (10/100 BaseT) for engineering tasks or TCP/IP and UDP via IEC 61131-3 – 2 CAN interfaces, 1 of which is electrically isolated – 2 RS485 interfaces, 1 of which is electrically isolated – USB device – DHF21B version with PROFIBUS slave DP-V1, DeviceNet™ slave – DHR21B version with PROFINET slave, EtherNet/IP™ slave, Modbus TCP/IP slave – 8 digital I/Os (inputs/outputs) – Status display for PLC and fieldbus – Real-time clock – 2 MB program memory, 6 MB data memory – 32 KB retain variables, 24 KB system variables (retain) – Free-running tasks (min. 10 ms), 1 cyclical task (10 – 10 000 ms) – PC-readable memory card for firmware and application programs

9.1 Controller hardware

Controller for control cabinet installation



Controller performance class “advanced”

DHx41B control card

Variants	<ul style="list-style-type: none"> – DHE41B version with Ethernet interface – DHF41B version with additional PROFIBUS and DeviceNet™ slave interface – DHR41B version with additional PROFINET/EtherNet/IP™/Modbus TCP/IP slave interface
Features	<ul style="list-style-type: none"> – Motion and logic controller for short response times – MultiMotion Light motion operating system and technology module – Motion control for up to 64 axes via SBus, or high performance with SBUS^{PLUS} – MOVI-PLC® I/O system via SBus, or high-performance implementation with SBUS^{PLUS} – SD card for easy unit replacement and recipe management – Rapid engineering via USB and Ethernet
Technical data	<ul style="list-style-type: none"> – 1 x Ethernet interface (10/100 BaseT) for engineering tasks or TCP/IP and UDP via IEC 61131-3 – 1 x Ethernet interface as SBUS^{PLUS} (EtherCAT®) master – 2 CAN interfaces, 1 of which is electrically isolated – 2 RS485 interfaces, 1 of which is electrically isolated – USB device – DHF41B version with PROFIBUS slave DP-V1, DeviceNet™ slave (DHF41B) – DHR41B version with PROFINET slave, EtherNet/IP™ slave, Modbus TCP/IP slave – 8 digital I/Os (inputs/outputs) – Status display for PLC and fieldbus – 4 MB program memory, 12 MB data memory – 32 KB retain variables, 24 KB system variables (retain) – Free-running tasks (min. 10 ms), 8 cyclical tasks (1 – 10 000 ms) – PC-readable memory card for firmware and application programs



Controller performance class “power”

UHX71B control card power

Variants	<ul style="list-style-type: none"> – UHX71B version with Ethernet interface – UHX71B-OSP71B version with additional PROFIBUS slave interface – UHX71B-OSR71B version with additional PROFINET/EtherNet/IP™/Modbus TCP/IP slave interface
Features	<ul style="list-style-type: none"> – Available in unit designs T0-T25 – Reduced number of interfaces, with all functions run via one controller <ul style="list-style-type: none"> - Demanding technology functions such as cams or electronic gear unit - 3D robotic functions with up to 8 degrees of freedom – Smooth, efficient implementation of highly complex machines – Up to 32 centrally processed motion and logic control axes in one millisecond – Sufficient processing power readily available, for even the most demanding application programs – Fast, synchronized SBUS^{PLUS} for coordinating drives – A CFast memory card for firmware, applications, and operating data facilitates the replacement of units and extremely fast data access
Technical data	<ul style="list-style-type: none"> – Intel Core2Duo 2.2 GHz processor – 1 x GB Ethernet (10/100 BaseT) for engineering tasks or TCP/IP and UDP via IEC 61131-3 – 1 x Ethernet interface for SBUS^{PLUS} – 16 MB program memory, 64 MB data memory – 32 kB retain variables, 24 kB system variables (retain) – Free-running tasks and 8 cyclical tasks (1 – 10 000 ms) – PC-readable memory card for firmware and application programs – Optional OSC71B CAN interface

9.1 Controller hardware

Accessories and options for controllers



Memory cards

Memory cards for “standard” and “advanced” performance-class controllers

- OMH41B
- OMC41B
- OMH71B
- OMW71B / OMW72B

ORV71C dongle for UHX71B

Dongle for visualization runtime

Implement high-performance visualization solutions using HMI-Builder.PRO and the Windows operating system in MOVI-PLC®.



I/O expansions

I/O expansions for control cabinet installations and decentralized installations

- MOVI-PLC® I/O system B
- MOVI-PLC® I/O system C
- SNI I/O system
- I/O expansions for automating your machine modules and entire systems



Interfaces

OSC71B CAN interface for UHX71B

The OSC71B option allows you to add a CAN bus interface to the existing range of interfaces for the MOVI-PLC[®] power. This enables stations to be operated on the MOVI-PLC[®] power controller without the need for SBUS^{PLUS} (MOVIGEAR[®]).

9.2 Controller software

Free programming MOVI-PLC®



Efficient engineering with MultiMotion motion control platform

Your advantages

- Universal platform: We provide support for all controllers in all performance classes as well as the entire range of drive electronics.
- Extensive functionality: Thanks to the integration of a wide range of motion control functions.
- Convenient parameterization: Graphical tools are provided for configuration and diagnostics.
- Efficient engineering: Many functions can be implemented after simple parameterization.

MultiMotion motion control platform

- For MOVI-PLC® advanced and MOVI-PLC® power as of technology level T2
- Supports up to 64 axes
- Single axis functions: Positioning, referencing, speed specification, and tracking
- Touch probe function
- Processing of distance encoders
- Technology functions: Synchronous operation, electronic cam functions, and interpolation with different engagement and disengagement mechanisms
- Cam switch for up to 8 cam tracks

MultiMotion Light motion control platform

- For MOVI-PLC® standard, MOVI-PLC® advanced and MOVI-PLC® power as of technology level T0
- Supports up to 64 axes
- Single axis functions: Positioning, referencing, speed specification, and tracking
- Touch probe function
- Processing of distance encoders

Technology modules

- HandlingKinematics
- Kinematics
- effiSRS energy-saving storage/retrieval system
- Winder

Parameterizable solutions configurable control unit (CCU)



Parameterize rather than program, using our CCU (Configurable Control Unit)

Your advantages

- **Parameterization instead of programming**
Graphical configurators allow you to parameterize predefined application and technology modules that can be run directly.
- **Easy startup**
Our standardized application modules allow for quick startup, without the need for time-consuming programming.
- **Optimize the application**
We provide a wide range of diagnostics tools for optimizing your applications.

Configure applications quickly and easily using our Application Configurator for CCUs:

- Graphical configuration of modules via PC
- Standardized single-axis and multiple-axis application modules can be configured and run directly
- Modules can be controlled via a standardized process data interface
- A special control mode allows for pre-startup, without the need for a higher-level PLC (programmable logic controller)
- Shorter response times when coordinating multiple axes
- Integrated diagnostics make startup quicker and smoother

Single-axis application modules

- Speed control
- Universal module: Speed, positioning, modulo, remaining distance
- Universal module technology, with phase-synchronous operation
- Rapid/creep speed positioning

Multi-axis application modules

- HandlingKinematics: Implementation of kinematics and handling applications
- effiSRS: Energy-optimized coordination of drive and lifting axes for storage/retrieval systems
- Winding systems: For effortless winding and unwinding of materials
- SyncCrane: For easy control of crane bridges and lifts

10

OPERATION AND STARTUP

10.1 Operator panels

DOP11C operator panel

294

Keypads

296

Interface adapter

297

10.2 Software

MOVITOOLS® MotionStudio

engineering software

298

MOVIVISION® plant software

300

LT Shell

302





10.1 Operator panels

Visualization and diagnostics



NEW: Operator panels of the DOP11C generation

Features

- Standardized, modern panel series with touchscreen, high resolution color display and wide viewing angle
- Consistent product portfolio with screen sizes from 4.3" to 15"
- Optimized on-screen keyboard makes it easier to input text, even for smaller panels
- Faster processors with improved performance
- More RAM gives you the scope to carry out even the most sophisticated visualization projects
- Option to expand memory by means of an SD card or USB stick, e.g. for logging visualization data
- Flexible communication connections due to sophisticated interfaces and driver protocols
- The new Windows-based platform MOVI-PLC® power is now available for the most demanding visualization tasks for use with durable 12" and 15" monitors. To use this, you have to activate runtime visualization in HMI-Builder.PRO with a USB dongle.
- Uniform appearance for both Windows-based and panel-based systems
- Housing:
 - DOP11C40/70/100/120 and 150 made of die-cast aluminum
 - DOP11C51, more cost-efficient due to plastic housing

HMI-Builder.PRO software



- Optimal interaction between visualization and SEW control technology
- Perfect system integration as an integral component of MOVITOOLS® MotionStudio
- Consistent development environment for the complete C unit series (from the smallest 4.3" panel to the high-end 15" visualization unit supported by MOVI-PLC® Power)
- Minimal configuration effort thanks to modern, efficient program design
- Numerous integrated HMI functions such as recipe management, alarm management, integrated Web server and much more increase operating security and reduce development costs
- For complex visualization tasks, the open scripting functionality in C# offers the full flexibility of .NET Framework architecture
- Integrated simulation mode allows you to configure and test visualization tasks in advance – even without hardware

Operator panels of the DOP11C generation

Panel type	Display	Operation	Interfaces	Processor/memory
DOP11C-40	4.3", 480 x 272 pixels, 65k colors	Touch display panel (resistive)	RS232, RS422/RS485 interface, Ethernet, SD card slot, USB	ARM9 (400 MHz) – RAM: 128 MB (DDR2) – Application memory: 80 MB
DOP11C-51	5", 800 x 480 pixels, 65k colors	Touch display panel (resistive) Limited functionality	RS232, RS422/RS485 interface, Ethernet, USB	ARM9 (400 MHz) – RAM: 128 MB (DDR2) – Application memory: 200 MB
DOP11C-70	7", 800 x 480 pixels, 65k colors	Touch display panel (resistive)	RS232, RS422/RS485 interface, Ethernet, SD card slot, USB	ARM9 (400 MHz) – RAM: 128 MB (DDR2) – Application memory: 80 MB
DOP11C-100	10.4", 640 x 480 pixels, 65k colors	Touch display panel (resistive)	RS232, RS422/RS485 interface, Ethernet, SD card slot, USB	ARM9 (400 MHz) – RAM: 128 MB (DDR2) – Application memory: 80 MB
DOP11C-120	12.1", 1280 x 800 pixels, 262k colors	Touch display panel (resistive)	RS232, RS422/RS485 interface, Ethernet, SD card slot, USB	Intel Atom (1.1 GHz) – RAM: 1 GB (DDR2) – Application memory: > = 1.4 GB
DOP11C-150	15.4", 1280 x 800 pixels, 262k colors	Touch display panel (resistive)	RS232, RS422/RS485 interface, Ethernet, SD card slot, USB	Intel Atom (1.1 GHz) – RAM: 1 GB (DDR2) – Application memory: > = 1.4 GB
Monitor type (MOVI-PLC® power)				
OPT71C-120	Display 12", 1280 x 800 pixels, 16 million colors	Touch display monitor in connection with MOVI-PLC® power	DVI, USB for touch functionality	
OPT71C-150	Display 15", 1280 x 800 pixels, 16 million colors	Touch display monitor in connection with MOVI-PLC® power	DVI, USB for touch functionality	
Device type license (MOVI-PLC® power)				
ORV71C	USB license dongle for using the visualization runtime integrated in HMI-Builder-PRO without a time limit.			

10.1 Operator panels

Keypads



Keypads for inverters

Properties	<ul style="list-style-type: none"> – Keypads for MOVITRAC® B and MOVIDRIVE® B inverters – Fast and convenient startup, diagnostics, or status display without PC 	
	FBG11B basic operator terminal for MOVITRAC® B	DBG60B keypad for MOVITRAC® B and MOVIDRIVE® B
Functions	<ul style="list-style-type: none"> – Visualization of process values and status – Fault memory queries and fault reset – Display and setting of parameters – Data backup and transmission of parameter sets – Easy-to-use startup menu for motors from SEW-EURODRIVE and third parties – Manual control of MOVITRAC® B 	<ul style="list-style-type: none"> – Visualization of process values and status – Status displays of digital inputs/outputs – Fault memory queries and fault reset – Display and setting of parameters and service parameters – Data backup and transmission of parameter to other MOVITRAC® B or MOVIDRIVE® B – Easy-to-use startup menu for VFC mode with the MOVIDRIVE® B – Manual control of MOVITRAC® B and MOVIDRIVE® B as well as the decentralized MOVIMOT® standard inverters (gearmotor with integrated frequency inverter)
Features	<ul style="list-style-type: none"> – 5-digit 7-segment display / 6 keys / 8 pictograms / setpoint adjuster – Selection of quick menu or complete menu – Can be plugged onto the inverter (during operation) – IP20 degree of protection (EN 60529) – LED display when IPOS® program is started 	<ul style="list-style-type: none"> – Illuminated plain text display: choice of up to 7 languages with MOVITRAC® B and more than 12 languages with MOVIDRIVE® B – Keypad with 21 keys – Selection of quick menu and complete menu; with MOVIDRIVE® B user menu, detailed parameter menu and startup menu in VFC operating mode – Can be plugged onto the inverter (during operation) – Can be connected via extension cable DKG60B (5 m) – IP40 degree of protection (EN 60529)

Interface adapter



Interface adapters for inverters

Properties	<ul style="list-style-type: none"> – “Translation aid” for communication between the drive technology components on all system levels and during engineering – Adapt signal levels and coding of the different communication technologies – Immediate data access
Types	<ul style="list-style-type: none"> – USBxxA to RS485 – USBxxA to SBus – RS232 to RS485

10.2 Software

Engineering software



MOVITOOLS® MotionStudio

Features

- Modular software concept for consistent engineering: Startup, control, diagnostics, communication, and visualization
- For parameterizing, programming, and diagnosing most inverter series of SEW EURODRIVE – independent of the device
- Convenient drive startup and parameter setting
- Drive diagnostics using the built-in oscilloscope function
- Creation of application and user programs in high-level language C, assembler or IEC 61131-3
- View status of connected units
- Fieldbus communication is diagnosed using a bus monitor
- Controlling technology functions
- Ready-to-use application modules for various applications
- Electronic nameplates of SEW-EURODRIVE gearmotors are used for automatic motor adjustment





Communication interfaces

MOVITOOLS® MotionStudio supports engineering via:
 Ethernet TCP/IP, PROFINET IO, EtherNet/IP™, MODBUS TCP

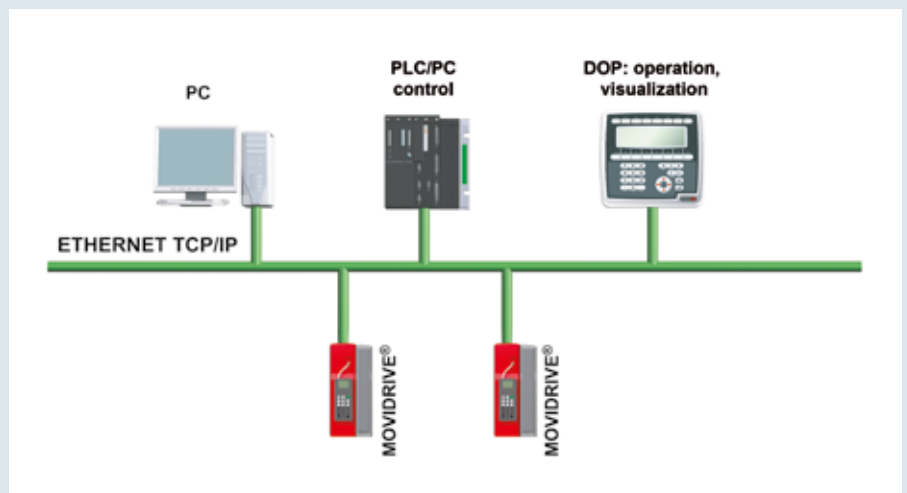
- EtherCAT®
- PROFIBUS DPV1, CAN, DeviceNet™

and the non-proprietary software interface **TCI Tool Calling Interface**



Tool	Functionality
	<p>Startup:</p> <ul style="list-style-type: none"> – Configuration and startup: To adapt the inverter to the connected motor and optimize current, speed and position controllers – Manual mode: The tool allows for manually controlling the units directly from the PC
	<p>Parameterization:</p> <ul style="list-style-type: none"> – Parameter tree: Standardized editor for parameterization of various unit types – PDO editor: A process data object editor for graphic configuration of process data for the MOVIAXIS® multi-axis servo inverter – Gateway configurator: Uniform tool for diagnostics and configuration of the fieldbus gateways UFx41B, DFX and MOVIFIT® with Classic and Technology function levels
	<p>Diagnostics and visualization:</p> <ul style="list-style-type: none"> – Status: Support for unit diagnostics, communicates general unit status information, manual unit reset possible – Application Builder: Editor for designing application-specific visualization and application-specific diagnostics. Visualization is connected via file download with the IPOS® inverter program and the parameter settings. – Fieldbus monitor: Tool for running diagnostics on the communication between the fieldbus and the unit (monitor mode), and the setpoint selection on the unit independently of the control (control mode) – Scope: Diagnostics are performed by using an oscilloscope program for all SEW-EURODRIVE inverters
	<p>Programming:</p> <ul style="list-style-type: none"> – PLC editor: Programming MOVI-PLC® controllers using application programs written once; can be applied independently of the unit – IPOS® assembler and compiler

10.2 Software

Parameterizable plant software



MOVIVISION®

Features

- Parameterizing rather than programming
- Track outline
- Integrated track visualization and operation
- Manual operation
- Virtual pre-startup using plant simulation (2D, 3D)
- Decentralized installation with central data management
- Access authorization management
- Automatic sequence of motion coordination (collision protection, synchronous travel)
- Ensuring independent production flows (routing management, specified targets)
- Parameterizable data exchange with higher-level controller
- Inclusion of production/part data
- Exchanging production-relevant data with higher-level systems
- Special additional functionalities thanks to technological functions (TecUnits)
- Support for safety technology



Your advantages

- **Simple planning and configuration**
Using the parameterizable conveyor functions in combination with virtual configuration, startup and simulation
- **Simple startup**
Thanks to parameterization that does not require special knowledge of programming
- **High flexibility in the event of changes in the production**
Thanks to the intuitive operation and parameterization
- **Precise troubleshooting**
Thanks to logging, simulation, virtual diagnostics and root cause resolution. External support via VPN possible
- **Increased productivity**
With fast diagnostics, remote maintenance and simple on-site maintenance

Application examples

- Single-axis applications such as roller conveyors
- Single or multi-axis applications such as rotary tables, lateral conveyors, lifting/lowering stations, conveyor trolleys
- MAXOLUTION® system solutions such as skillets with lifting tables, electrified monorail systems and automated guided vehicle systems

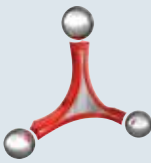
Functions

	<ul style="list-style-type: none"> – Designing and project planning of the system
	<ul style="list-style-type: none"> – Plant data management and administration
	<ul style="list-style-type: none"> – Plant parameterization – Plant startup – Simplified plant maintenance
	<ul style="list-style-type: none"> – Diagnostics of the system – Plant operation and monitoring – Simulation
MOVIVISION® parameter and diagnostics tool	<ul style="list-style-type: none"> – Windows-based parameter and diagnostics tool – User access to the central database of the MOVIVISION® server
MOVIVISION® server	<ul style="list-style-type: none"> – All data is stored in one central database – A link to the connected decentralized control components is established – Data is exchanged between server and decentralized control components via fieldbus and/or networks – Only here, parameters are set or changed – Management and supervision of access authorizations – High degree of data security and user-friendliness – Data exchange between the server and decentralized components via fieldbuses and/or networks – Activation of automatic parameter download during unit replacement – Error analysis possible with logging – Catalog functions
MOVIVISION® client	<ul style="list-style-type: none"> – The interface displays the data of the decentralized control components visually – Parameterization and diagnostics on different levels up to the inverter – The data for every device is visualized separately for parameterization and diagnostics data – It is possible to grant different access rights to users, e.g. for monitoring, for parameterizing, for initial startup, for unit replacement, etc.

10.2 Software

Software LT Shell



Software LT Shell

Properties

- Function-related software for fast startup with parameter management and network monitoring with the aid of a PC
- Multi-language programming tool for MOVITRAC® LTE-B basic inverters, MOVITRAC® LTP-B standard inverters and the MOVIFIT® basic decentralized inverter via RS485 data exchange

Functions

- Upload and download of parameters
- Saving parameters
- Exporting inverter parameters
- Controlling the inverter
- Monitoring the state of the motor and inputs/outputs

11 SAFETY TECHNOLOGY

11.1 Control cabinet installation

Integrated safe communication for inverters

- with safe communication MOVISAFE® DFS11B/21B,
DCS21B, DCS22B) 306

- Self-sufficient communication MOVISAFE® DCS31B
and DCS32B 307

Modular safety technology for inverters

- Safety modules compact (up to 2 axes)
MOVISAFE® UCS10B/PS, UCS11B/PS, UCS12B/PS 308

- Multi-axis safety modules (up to 12 axes)
UCS50B and UCS51B 309

11.2 Decentralized installation

310





11.1 Control cabinet installation

safetyDRIVE: Functional safety in the control cabinet



With safe communication

MOVISAFE® DFS11B/21B for stop functions	<ul style="list-style-type: none"> – Optimized stop monitoring for all drive components – This simplifies the planning and implementation of every type of system
MOVISAFE® DFS12B/22B for safe communication	<ul style="list-style-type: none"> – Perfectly designed for motion and position monitoring – Easy and compact integration into the MOVIDRIVE® B drive inverter
MOVISAFE® DCS22B for motion monitoring	<ul style="list-style-type: none"> – Extensive and safe monitoring of motion sequences – Designed for compact integration into MOVIDRIVE® B drive inverters, sizes 1 to 7
MOVISAFE® DCS21B for motion and position monitoring	<ul style="list-style-type: none"> – Extensive and safe monitoring of motion and positioning sequences – Easy and compact integration into the MOVIDRIVE® B drive inverter
Safety functions according to IEC 61800-5-2	<ul style="list-style-type: none"> – MOVISAFE® DFS11B/21B: STO, SS1 – MOVISAFE® DCS21B: STO, SS1, SS2, SOS, SLS, SDI, SSR, SSM, SLI, SCA, SLP – MOVISAFE® DCS22B: STO, SS1, SS2, SOS, SLS, SDI, SSR, SSM
PROFIsafe via PROFIBUS DP or PROFINET IO	<ul style="list-style-type: none"> – MOVISAFE® DFS11B/21B: communication via PROFIBUS DP or PROFINET IO – MOVISAFE® DCS21B: <ul style="list-style-type: none"> - DFS12B - communication via PROFIBUS DP - DFS22B - communication via PROFINET IO – MOVISAFE® DCS22B: <ul style="list-style-type: none"> - DFS12B - communication via PROFIBUS DP - DFS22B - communication via PROFINET IO
Number of inputs/outputs	<ul style="list-style-type: none"> – MOVISAFE® DFS11B/21B: <ul style="list-style-type: none"> - 1 safe digital output – MOVISAFE® DCS..B: <ul style="list-style-type: none"> - 8 safe digital inputs - 3 safe digital outputs - Installed axis monitoring function - Designed for integration in drive inverters – MOVISAFE® DFS11B/21B for MOVIDRIVE® B (sizes 0 to 7) and MOVITRAC® B inverters (sizes 0 to 5) – MOVISAFE® DFS12B/22B for MOVIDRIVE® B inverters (sizes 1 to 7) – MOVISAFE® DCS..B for MOVIDRIVE® B inverters (sizes 1 to 7)
Application areas for DFS..B and DCS..B safety cards in control cabinet drive technology	<ul style="list-style-type: none"> – Storage/retrieval systems – Travel carriages – Cranes – Handling gantries – Baggage handling systems – Assembly sections: press plant, body shop, paint, final assembly



Independent safety technology

MOVISAFE® DCS31B for motion and position monitoring

- Safety functions according to IEC 61800-5-2: STO, SS1, SS2, SOS, SLS, SDI, SSR, SSM, SLI, SCA, SLP
- 8 safe digital inputs
- 3 safe digital outputs
- Installed axis monitoring function
- Integrated logic processing for freely connecting inputs/outputs
- Designed for integration in MOVIDRIVE® B drive inverters (sizes 1 to 7)

MOVISAFE® DCS32B for motion monitoring

- Safety functions according to IEC 61800-5-2: STO, SS1, SS2, SOS, SLS, SDI, SSR, SSM
- 8 safe digital inputs
- 3 safe digital outputs
- Installed axis monitoring function
- Integrated logic processing for freely connecting inputs/outputs
- Designed for integration in MOVIDRIVE® B drive inverters (sizes 1 to 7)

Application areas for DCS..B safety cards in control cabinet drive technology

- Storage/retrieval systems
- Travel carriages
- Cranes
- Handling gantries
- Baggage handling systems
- Assembly sections: press plant, body shop, paint, final assembly

MOVISAFE®: Functional safety integrated in the inverter

Properties

Your advantages:

- Profit from the flexibility as our safetyDRIVE components can be individually assembled for every type of system
- Minimize operational risks by eliminating all sources of danger with the safetyDRIVE functional safety
- Drive your system efficiently as the safetyDRIVE safety components save you costs for external safety systems
- Ensure standardized operation as all safetyDRIVE modules comply with the applicable statutory provisions

MOVISAFE®: Modular safety in inverters

- MOVISAFE® DCS..B option cards for the MOVIDRIVE® B drive inverter
- MOVISAFE® UCS..B safety modules for all control cabinet inverters MOVIAXIS®, MOVITRAC®, MOVIDRIVE®
- Multi-axis UCS..B logic modules as integrated logic processing for freely connected inputs/ outputs

11.1 Control cabinet installation

Modular safety for the inverter



Safety modules – compact (for up to 2 axes)

	<ul style="list-style-type: none"> – UCS10B safety module – UCS10B/PS safety module: PROFIsafe via PROFIBUS DP/PROFINET IO – UCS11B safety module – UCS11B/PS safety module: PROFIsafe via PROFIBUS DP/PROFINET IO – UCS12B safety module – UCS12B/PS safety module: PROFIsafe via PROFIBUS DP/PROFINET IO – UCS26B communication module for optional PROFIBUS DP communication – UCS27B communication module for optional PROFINET IO communication
<p>Features</p>	<ul style="list-style-type: none"> – Integrated logic processing for freely connecting input/output axis monitoring functionality: <ul style="list-style-type: none"> - UCS10B, UCS10B/PS: without encoder evaluation - UCS11B, UCS11B/PS: for 1 axis - UCS12B, UCS12B/PS: for up to 2 axes – Safety functions according to IEC 61800-5-2: <ul style="list-style-type: none"> - UCS10B, UCS10B/PS: STO, SS1c - UCS11B, UCS11B/PS, UCS12B, UCS12B/PS: STO, SS1, SS2, SOS, SLS, SDI, SSR, SSM, SLI, SCA, SLP – PROFIsafe via PROFIBUS DP and PROFINET IO for all UCS..B safety modules – Extensible with input/output modules: <ul style="list-style-type: none"> - up to 56 safe digital inputs - up to 32 safe outputs
<p>Areas of application</p>	<ul style="list-style-type: none"> – Scara robots – Application storage/retrieval system – Handling gantries – Special machine design – Palletizers



Safety modules – multi-axis (for up to 12 axes)

	<ul style="list-style-type: none"> – UCS50B safety module – UCS51B safety module – Safety module UCS50B/DP with PROFIBUS DP – Safety module UCS50B/PN with PROFINET IO – UCS61B safety module – UCS62B safety module – UCS63B safety module
Features	<ul style="list-style-type: none"> – Integrated logic processing for freely connecting inputs/outputs – Axis monitoring function for up to 12 axes – Safety functions according to IEC 61800-5-2: SS1, SS2, SOS, SDI, SLS, SSR, SLA, SAR, SSM, SLI, SCA, SLP – Can be expanded by input/output modules: <ul style="list-style-type: none"> - Up to 150 digital inputs/outputs - Up to 54 outputs
Areas of application	<ul style="list-style-type: none"> – Scara robots – Application storage/retrieval system – Handling gantries – Special machine design – Palletizers

11.2 Decentralized installation

safetyDRIVE: Functional safety



Decentralized installation with a decentralized MOVIFIT® MC or FC drive controller and integrated functional safety

Features and benefits

- Comprehensive safety functionality for disconnection, speed and direction of rotation monitoring (STO, SS1, SLS, SDI)
- Reduced wiring work thanks to the integration of functional safety technology
- Short total response times of the application due to direct monitoring and disconnection
- Fast startup with simple parameterization of complete safety functions
- Easy and guided validation of safety functionality
- Stand-alone safety solutions in independent operation without external safety controller possible
- Long product life of the safety components due to long service life (20 years)
- Easy integration of safe drive technology in existing plants with PROFIsafe communication
- Universal application in a PROFIsafe network via PROFIBUS and PROFINET IO
- Certified to (IEC 61508) SIL 2, (EN ISO 13849-1) PL d

MOVISAFE® S12 option

- Control via PROFIsafe with MOVISAFE® S12 option
- Safety functions according to IEC 61800-5-2:
 - Safe torque off (STO)
 - Safe stop (SS1(c))
 - Safe motion (SDI)
- Approvals
 - SIL 3 according to IEC 61508
 - PL e according to EN ISO 13849-1
- S12A variant
 - 4 safe inputs F-DI (OSSD-capable)
 - 2 pulse outputs
 - 2 safe outputs F-DO (2-pole)
 - 1 safe output, internal, STO (2-pole)
- S12B variant
 - 8 safe inputs F-DI (OSSD-capable)
 - 2 pulse outputs
 - 1 safe output, internal, STO (2-pole)

Application examples

- Roller conveyor
- Accumulating conveyor
- Corner transfer unit
- Transfer unit
- etc.



Decentralized installations with a decentralized drive, positioning and application controller:

- **MOVIPRO® SDC with integrated safety functions and**
- **MOVIPRO® ADC with decentralized MOVISAFE® HM31 safety controller**

Features and benefits

- Scalable safety technology for decentralized application inverter for simple and complex safety functions
- Reduced wiring work through the integration of functional safety technology
- Short total response times of the application due to direct monitoring and disconnection
- Very easy startup and validation of axis safety functions
- Flexible configuration and validation of complex, application-specific safety functions
- Stand-alone safety solutions in independent operation without external safety controller possible
- Long product life of the safety components due to long service life (20 years)
- Easy integration of safe drive technology in existing plants with PROFIsafe communication
- Universal application in a PROFIsafe network via PROFIBUS and PROFINET IO
- Certified to (IEC 61508) SIL 3, (EN ISO 13849-1) PL e

Simple project planning with MOVIPRO® SDC / ADC

- Control via PROFIsafe with MOVISAFE® S11 option
- Optional, safety-related brake disconnection (SBC)
- The integrated MOVISAFE® S11 option comes equipped with 4 safety-related inputs for connecting safe sensors and two safety-related outputs

Specific MOVIPRO® design with expanded functions as drive and system controller for MAXOLUTION® system solutions

- Decentralized MOVISAFE® HM31 safety controller
 - Free programming according to IEC 61131-3 per “drag & drop” using certified function modules (Motion Library PFF-HM31) and the “SILworX” engineering tool
 - Ready-to-use drive and application modules (Motion Library, SIL 3 or PL e certified) are available based on EN 61800-5-2 for mobile materials handling technology
 - SS1, SS2, SOS, SDI, SLS, SSR, SLA, SAR, SSM, SLI, SLP, SCA
 - Safe disconnection and stop
 - Safe range changeover
 - Safe movement and position monitoring
- Hardware assignment:
- 24 safe digital inputs (8 OSSD-capable) and 8 safe sinking/sourcing digital outputs
 - Safe counter inputs (HTL, TTL)
 - CAN and RS485 interfaces
- Certification:
- SIL 3 according to IEC 61508
 - PL e according to EN ISO 13849-1
- Safe communication:
- safeethernet (SIL 3, master & slave), also possible via WLAN
 - PROFINET PROFIsafe (controller/host & device/device)

Application examples

Electrified monorail systems for heavy loads, automated guided vehicle, scissor lift tables, lifting/lowering conveyors, lifting stations, transfer carriages, rotary feeders, rotary indexing tables, high-speed horizontal conveyors with positioning

12

CONTACTLESS ENERGY TRANSFER

12.1 Contactless energy transfer
MOVITRANS®

314



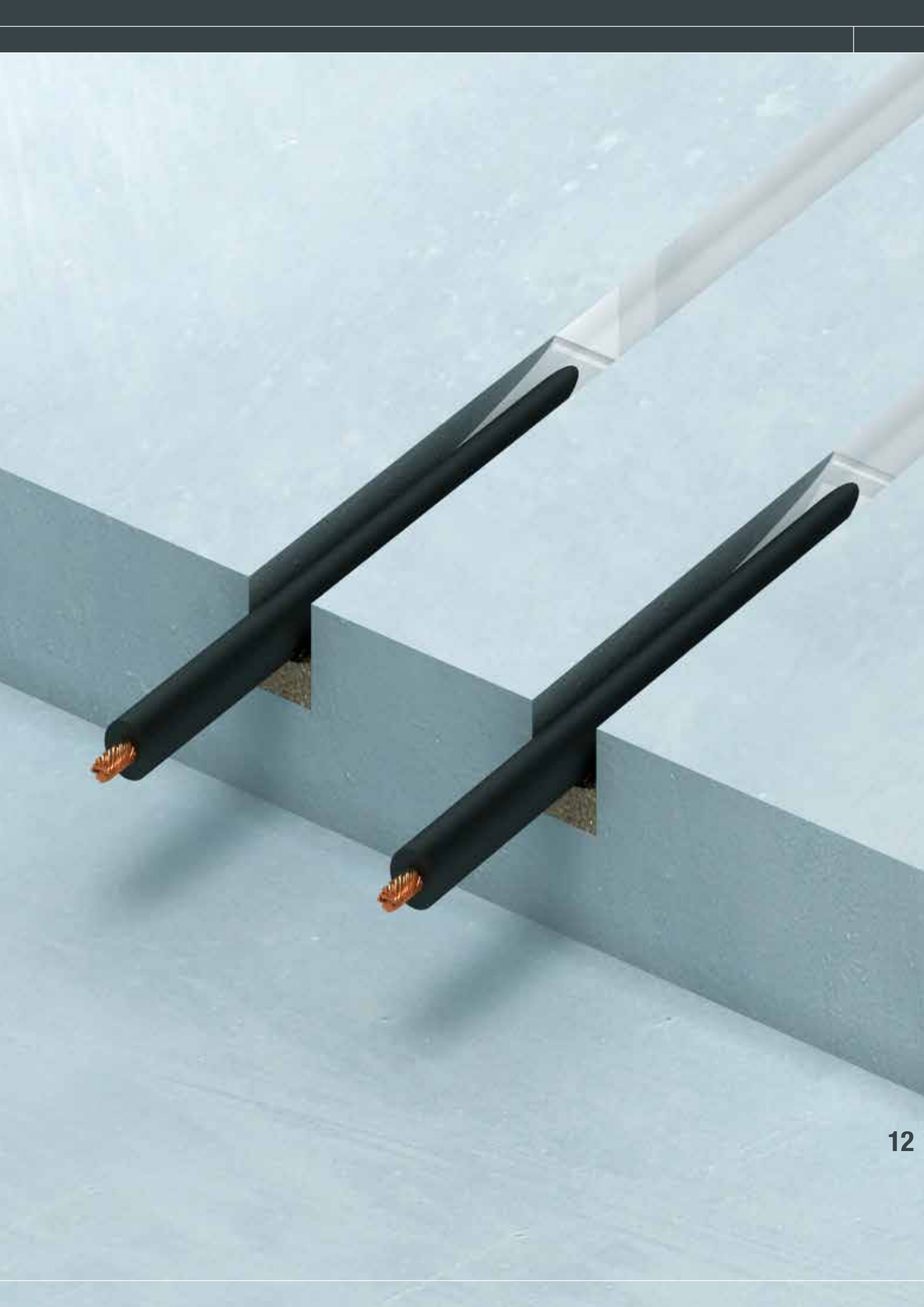

12.1 MOVITRANS® Contactless energy transfer



Features	<ul style="list-style-type: none"> – MOVITRANS®, the contactless energy transfer system from SEW-EURODRIVE, works on the principle of inductive energy transfer – Electrical energy is transferred without contact from a fixed conductor to one or more mobile consumers – The electromagnetic connection is made via an air gap and is not subject to wear; it is therefore maintenance-free – Contactless energy transfer is emission-free and resistant to contamination from external sources – Tested according to BGV B11
Areas of application	<ul style="list-style-type: none"> – Perfect supply system for all mobile applications – Long distances are covered at high speed – When maintenance-free operation is required – When additional environmental contaminants are not permitted in sensitive areas – In wet and humid areas
Stationary components	
TPS stationary converter	<ul style="list-style-type: none"> – Power: 4.0 kW or 16.0 kW – V_{line}: 380 V – 500 V \pm 10% – Degree of protection: IP20
TAS transformer module	<ul style="list-style-type: none"> – Power: 4.0 kW oder 16.0 kW – I_A: 60 A or 85 A – Degree of protection: IP10
TSC compensation capacitors	<ul style="list-style-type: none"> – Capacitance values: 2 μF, 4 μF, 8 μF, 16 μF or 32 μF – Output current: 60 A oder 85 A – Degree of protection: IP00

Mobile components

TPM12B mobile converter	<ul style="list-style-type: none"> - Nominal output power <ul style="list-style-type: none"> - when 4 THM10C units are connected: max. 3.6 kW - when 2 THM10E units are connected: max. 3.0 kW - Output voltage: DC 500 V - Additional output voltage: 24 V, max. 2 A - Degree of protection: IP65
THM10E pick-up	<ul style="list-style-type: none"> - Power: 1.5 kW - Degree of protection: IP65
THM10C pick-up	<ul style="list-style-type: none"> - Rated power: 0.8 kW - Peak power: 0.9 kW - Degree of protection: IP65
TVS connection distributor	<ul style="list-style-type: none"> - Degree of protection: IP65 - Output current: 60 A or 85 A
TCS compensation box	<ul style="list-style-type: none"> - Degree of protection: IP65 - Output current: 60 A or 85 A - Compensates a travel distance of 25 to 30 m

12.1 MOVITRANS® Contactless energy transfer

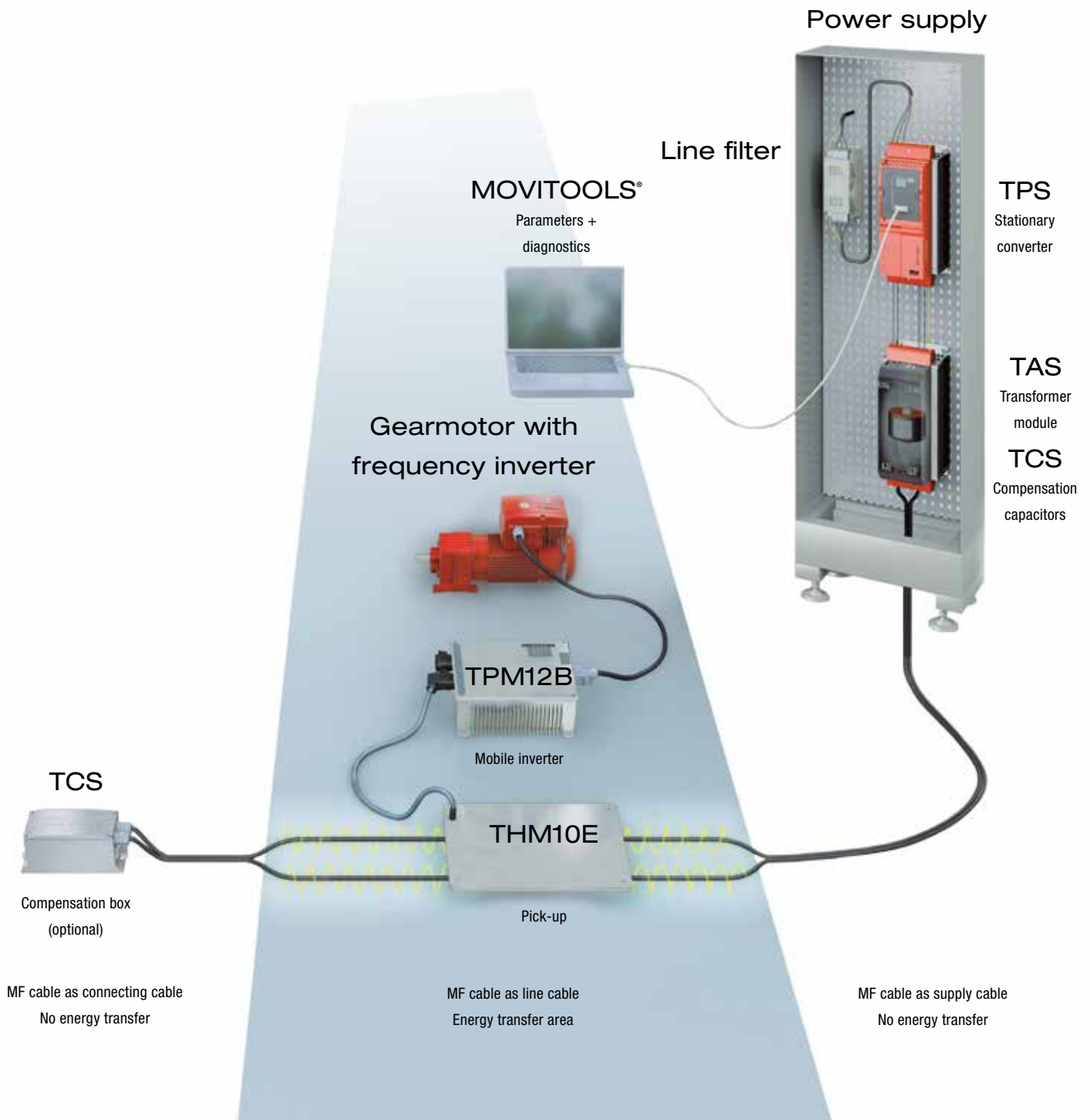

MOVITRANS® with flat pick-up
(THM10E)

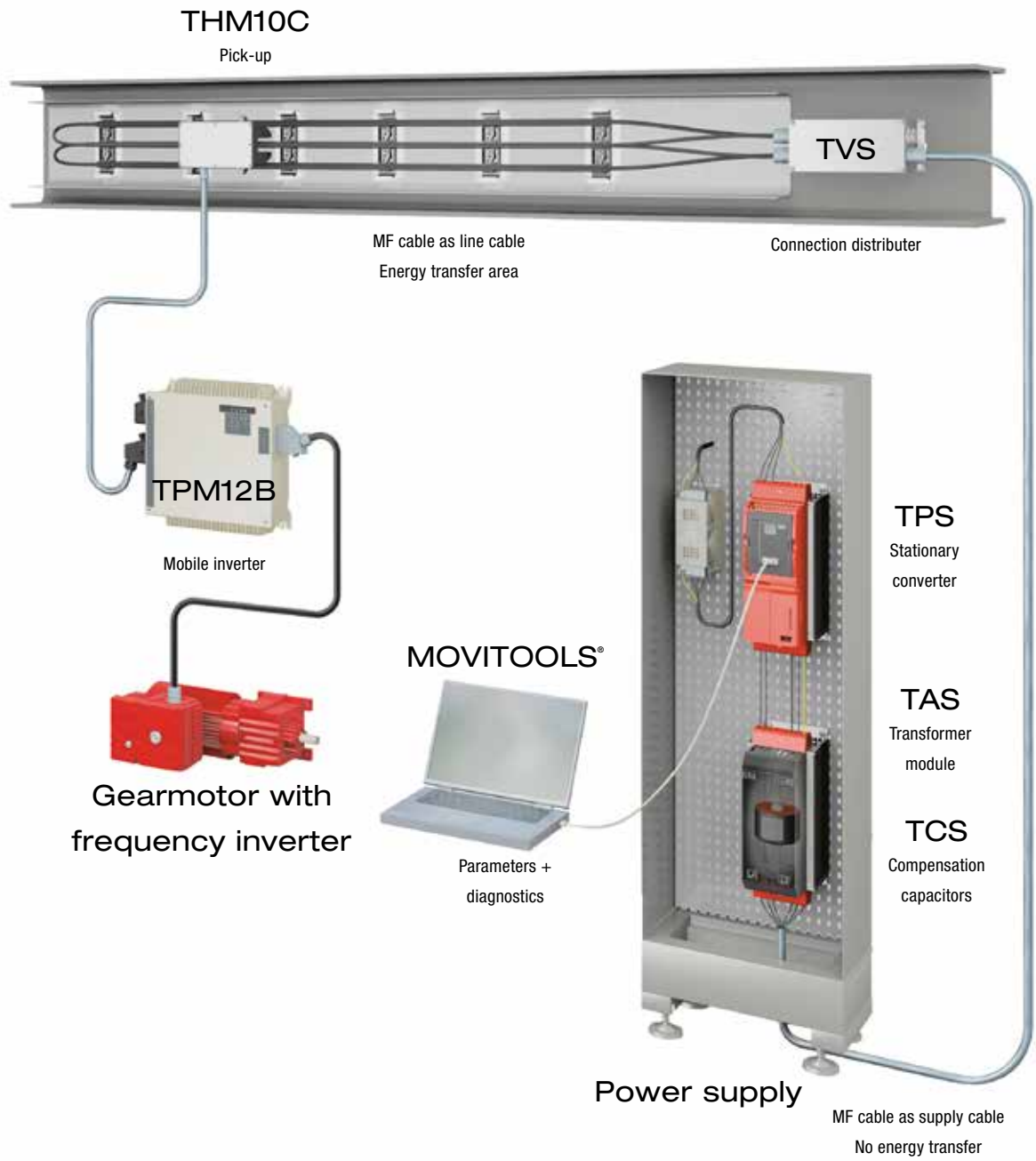

MOVITRANS® with U-shaped pick-up (THM10C)

TIS
Installation components for line cable support



13 DIDACTICS MODULES

13.1 Electromechanics	320
13.2 Gear unit technology	322





13.1 Didactics – Electromechanics

Hands-on experience of drive technology



Electromechanics modules

Subject area 8: Selecting and integrating drives, perfect for all trainings regarding electromechanics and mechatronics

The modular didactics concept Electromechanics was especially designed for the learning field-oriented training in drive technology for electronics engineers. It combines practical exercises for the operation of AC motors at the supply system and with frequency inverters. Further, the modular model concept allows for flexible education and training of specialists. For example, a master-slave situation with known functions (speed control, direction control, measuring functions) can be simulated with a higher-level PLC.

Modules (Didactics product series electromechanics)

- MOVIDRIVE® B drive inverter module (MDX)
- MOVIDRIVE® operating box (BDM)
- MOVITRAC® B frequency inverter module (MCB)
- MOVI4R-U® frequency inverter module (M4U)
- Motor unit (DRS.)
- Motor unit (CMP.)
- Motor load brake module (MLB)
- Motor protection switch module (MSS)
- Reversing contactor switch module (WSS)
- Star/delta switchover module (SDU)
- Motor load diagnostics module (MLD)

Advantages

- Flexible and modular test setup
- Easy integration possibilities in existing laboratory concepts
- Realistic measurements of electric and mechanical values
- Industry standard, safe and reproducible



NEW: MOVIDRIVE® drive inverter module (MDX)

Design:

- 3-phase 400 V line voltage
- Control via digital and analog signals or control via PROFIBUS or PROFINET
- Braking resistor connection routed outside
- Available with application inverter in size OM or 1
- Easy introduction to safety functions such as STO
- Suitable for AC asynchronous and AC synchronous motors
- Acoustic protection cover monitoring in combination with MLB



MOVITRAC® B frequency inverter module (MCB)

Design:

- 1-phase 230 V line voltage
- Control via digital and analog signals or control via PROFIBUS or PROFINET
- Braking resistor connection routed outside
- Suitable for AC asynchronous motors
- Acoustic protection cover monitoring in combination with MLB



NEW: MOVI4R-U® frequency inverter module (M4U)

Design:

- 1-phase 230 V line voltage
- Easy and fast startup and parameterization
- With boost function
- Very robust due to aluminum housing
- Control via digital and analog signals
- Suitable for AC asynchronous motors



Motor load brake module (MLB)

Design:

- AC asynchronous motor type DRS71S4
 - Nominal power 0.37 kW
 - Voltage 230 V / 400 V
 - Insulation class F
- Temperature sensor
- EI7C built-in encoder
- Acoustic protection cover monitoring in combination with MCB or MDX



Motor unit (DRS.)

Design:

- AC asynchronous motor type DRS71S4
 - Nominal power 0.37 kW
 - Voltage 230 V / 400 V
 - Insulation class F
- Temperature sensor
- EI7C built-in encoder
- Safe footing due to suitable base plate
- Easy transport



Motor unit (CMP.)

Design:

- AC synchronous motors type CMP50M
 - Nominal power 2.40 Nm
 - Voltage 400 V
 - Insulation class F
- Temperature sensor
- ES1H encoder Hiperface® single-turn
- Safe footing due to suitable base plate
- Easy transport

13.2 Didactics – Gear unit technology

Gear units are easily mounted



Helical and helical-bevel gear units

Ideal for all trainings for employees working with metal, mechanotricians, industrial mechanics. Subject area 10 – Gear units

A standard helical gear unit and a helical-bevel gear unit were adapted especially for this didactic purpose. This allows for repeatedly easy assembly and disassembly of various machine elements without expensive pressing tools during the trainings.

Advantages

- All components have corrosion protection
 - Gear units can be easily assembled and disassembled (reproducible and wear-free)
 - Clear presentation of all components and tools (short preparation and follow-up times)
 - All required tools are available
-



R57FAD2 helical gear unit

Features

- The gear unit is available with 2 and 3 stages
- Quick guide included
- Safe assembly and disassembly of the machine elements without pressing tools
- Safe footing due to foot/flange-mounted design
- Function test with handwheel
- Close-to-production design

Gear ratio (in theory)

- $i = 16.79$ (2 stages)
- $i = 26.97$ (3 stages)



K47AD2 helical-bevel gear unit

Features

- Setting the gear backlash and bearing clearance of the bevel gear and the pinion shaft
- Quick guide included
- Safe assembly and disassembly of the machine elements without pressing tools
- Safe footing due to foot-mounted design
- Function test with handwheel
- Close-to-production design

Gear ratio (in theory)

- $i = 35.39$

13.2 Didactics – Gear unit technology

Gear units are easily mounted



NEW: Helical gear unit demo unit cabinet

Features

- Gear unit with 2 or 3 stages
- Quick guide included
- Safe assembly and disassembly of the machine elements without pressing tools
- Safe footing due to foot/flange-mounted design
- Function test with handwheel
- Close-to-production design
- Available with different table heights

Gear ratio (in theory)

- $i = 16.79$ (2 stages)
- $i = 26.97$ (3 stages)



NEW: Helical-bevel gear demo unit cabinet

Features

- Setting the gear backlash and bearing clearance
- Quick guide included
- Safe assembly and disassembly of the machine elements without pressing tools
- Safe footing due to foot-mounted design
- Function test with handwheel
- Close-to-production design
- Available with different table heights

Gear ratio (in theory)

- $i = 35.39$

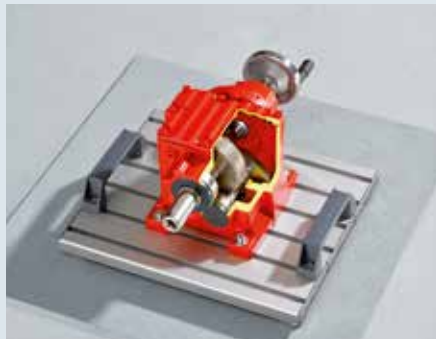

NEW: Cut-away model of a helical gear unit

Features

- Shows the structure of a helical gearing in motion
- Safe footing due to suitable base plate
- Easy transport
- Function test with handwheel
- Close-to-production design
- Gears, pinion shafts and shafts are protected against corrosion



NEW: Cut-away model of a helical-bevel gear unit

Features

- Shows the structure of a bevel gearing in motion
- Safe footing due to suitable base plate
- Easy transport
- Function test with handwheel
- Close-to-production design
- Gears, pinion shafts and shafts are protected against corrosion

→ If we sparked your interest, contact our Didactics team by phone or via e-mail:
 Contact person Lenita Schmidt
 Tel. +49 7251 75-3214,
lenita.schmidt@sew-eurodrive.de

SEW-EURODRIVE is right there for you:

Argentina

Tel. +54 3327 4572-84
Fax +54 3327 4572-21
sewar@sew-eurodrive.com.ar

Australia

Tel. +61 3 9933-1000
Fax +61 3 9933-1003
enquires@sew-eurodrive.com.au

Austria

Tel. +43 1 617 55 00-0
Fax +43 1 617 55 00-30
sew@sew-eurodrive.at

Belarus

Tel. +375 17 298 47 56
Fax +375 17 298 47 54
sales@sew.by

Belgium

Tel. +32 16 386-311
Fax +32 16 386-336
info@sew-eurodrive.be

Brazil

Tel. +55 19 3835-8000
sew@sew.com.br

Canada

Tel. +1 905 791-1553
Fax +1 905 791-2999
marketing@sew-eurodrive.ca

Chile

Tel. +56 2 2757 7000
Fax +56 2 2757 7001
ventas@sew-eurodrive.cl

China

Tel. +86 22 25322612
Fax +86 22 25323273
info@sew-eurodrive.cn

Colombia

Tel. +57 1 54750-50
Fax +57 1 54750-44
sew@sew-eurodrive.com.co

Czech Republic

Tel. +420 255 709 601
Fax +420 235 350 613
sew@sew-eurodrive.cz

Denmark

Tel. +45 43 9585-00
Fax +45 43 9585-09
sew@sew-eurodrive.dk

Finland

Tel. +358 201 589-300
Fax +358 3 7806-211
sew@sew.fi

France

Tel. +33 3 88 73 67 00
Fax +33 3 88 73 66 00
sew@usocome.com

Great Britain

Tel. +44 1924 893-855
Fax +44 1924 893-702
info@sew-eurodrive.co.uk

Hungary

Tel. +36 1 437 06-58
Fax +36 1 437 06-50
office@sew-eurodrive.hu

India

Tel. +91 265 3045200
Fax +91 265 3045300
marketing@seweurodriveindia.com

Italy

Tel. +39 02 96 9801
Fax +39 02 96 980 999
sewit@sew-eurodrive.it

Ivory Coast

Tel. +225 21 21 81 05
Fax +225 21 25 30 47
info@sew-eurodrive.ci

Japan

Tel. +81 538 373811
Fax +81 538 373814
sewjapan@sew-eurodrive.co.jp

Kazakhstan

Tel. +7 727 238 1404
Fax +7 727 243 2696
sew@sew-eurodrive.kz

Malaysia

Tel. +60 7 3549409
Fax +60 7 3541404
sales@sew-eurodrive.com.my

Mexico

Tel. +52 442 1030-300
Fax +52 442 1030-301
scmexico@seweurodrive.com.mx

Mongolia

Tel. +976 77109997
Fax +976 77109997
sew@sew-eurodrive.mn

Morocco

Tel. +212 523 32 27 80/81
Fax +212 523 32 27 89
sew@sew-eurodrive.ma

Netherlands

Tel. +31 10 4463-700
Fax +31 10 4155-552
info@sew-eurodrive.nl

New Zealand

Tel. +64 9 2745627
Fax +64 9 2740165
sales@sew-eurodrive.co.nz

Norway

Tel. +47 69 241-020
Fax +47 69 241-040
sew@sew-eurodrive.no

Paraguay

Tel. +595 991 519695
Fax +595 21 3285539
sewpy@sew-eurodrive.com.py

Peru

Tel. +51 1 3495280
Fax +51 1 3493002
sewperu@sew-eurodrive.com.pe

Poland

Tel. +48 42 676 53 00
Fax +48 42 676 53 49
sew@sew-eurodrive.pl

Portugal

Tel. +351 231 20 9670
Fax +351 231 20 3685
infosew@sew-eurodrive.pt

Russia

Tel. +7 812 3332522
Fax +7 812 3332523
sew@sew-eurodrive.ru

Singapore

Tel. +65 68621701
Fax +65 68612827
sewsingapore@sew-eurodrive.com

Slovakia

Tel. +421 2 33595 202
Fax +421 2 33595 200
sew@sew-eurodrive.sk

South Africa

Tel. +27 11 248 7000
Fax +27 11 248 7289
info@sew.co.za

South Korea

Tel. +82 31 492-8051
Fax +82 31 492-8056
master.korea@sew-eurodrive.com

Spain

Tel. +34 94 4318470
Fax +34 94 4318471
sew.spain@sew-eurodrive.es

Sweden

Tel. +46 36 3442 00
Fax +46 36 3442 80
info@sew-eurodrive.se

Switzerland

Tel. +41 61 41717-17
Fax +41 61 41717-00
info@imhof-sew.ch

Tanzania

Tel. +255 22 277 5780
Fax +255 22 277 5788
uroos@sew.co.tz

Thailand

Tel. +66 38 454281
Fax +66 38 454288
sewthailand@sew-eurodrive.com

Turkey

Tel. +90 262 999 1000-04
Fax +90 262 999 1009
sew@sew-eurodrive.com.tr

Ukraine

Tel. +380 56 370 3211
Fax +380 56 372 2078
sew@sew-eurodrive.ua

Uruguay

Tel. +598 2 2118189
Fax +598 2 2118190
sewuy@sew-eurodrive.com.uy

USA

Tel. +1 864 439-7537
Fax +1 864 439-7830
csllyman@seweurodrive.com

Venezuela

Tel. +58 241 832-9804
Fax +58 241 838-6275
ventas@sew-eurodrive.com.ve

How we're driving the world



SEW-EURODRIVE
Driving the world

SEW
EURODRIVE

SEW-EURODRIVE GmbH & Co KG
P.O.Box 30 23
76642 Bruchsal/Germany
Tel. +49 7251 75-0
Fax +49 7251 75-1970
sew@sew-eurodrive.com

→ www.sew-eurodrive.com