



Installation manual

NewMotion
Home Advanced
2.1 / 2.2



newmotion[®]

A Member of the Shell Group

Table of content

1. Preface	3		
1.1. Original instructions	3	5.2.6. Charge point mounting	13
1.2. Copyright	3	5.2.7. Installation tools and materials	13
1.3. Disclaimer of liability	3	5.3. Preparation	15
1.4. About this document	3	5.4. Mounting	16
1.5. Used symbols in this document	3	5.4.1. Wall mount	16
1.6. Used abbreviations / terminology in this document	3	5.4.2. Pavement mount	19
		5.4.3. Soil mount	21
2. Safety	5	5.5. Electrical connection	24
2.1. Introduction	5	5.5.1. Power cable	24
2.2. Intended use and reasonably foreseeable misuse	5	5.5.2. Tethered charging cable	25
2.3. Qualification of installer	5	5.6. Wired network connection (optional)	27
2.4. Protective measures	5	5.7. Installation DPM module (optional)	28
2.4.1. Personal protective equipment (PPE)	5	5.7.1. Installing the DPM for Business module	28
2.5. Residual risks	6	5.7.2. Connecting the charge point to the DPM module	30
2.6. How to handle in case of an emergency	6	5.7.3. Connecting the charge point to a smart meter	31
2.7. Safety precautions	6	5.8. Finishing installation	32
2.7.1. Electricity	6		
2.8. Labels	6	6. Commissioning	34
		6.1. Activating the product	34
3. Description of the product	7	6.2. Checks before commissioning	34
3.1. Main parts	7	6.3. Switching on the product	34
3.2. Internal connections	7	6.4. Configuring the DPM module	35
3.2.1. Internal connections for tethered cable	8	6.5. Test charge point	35
3.3. Technical specifications	8	6.6. Regular use	35
3.4. Nameplate / markings	10	6.6.1. Start charging	35
		6.6.2. Stop charging	35
4. Transport and storage	10	6.6.3. Explanation of the LED colors	35
4.1. Transport	10	6.7. Tethered cable	35
4.2. Storage	10		
		7. Troubleshooting	36
5. Installation	11		
5.1. Scope of delivery/Check the contents	11	8. Maintenance	40
5.1.1. Home Advanced 2.1 / 2.2	11	8.1. Cleaning and sanitizing	40
5.1.2. Optional	11	8.1. Periodic maintenance	40
5.2. Installation materials (not provided)	12		
5.2.1. Power cable	12	9. Disposal	40
5.2.2. Data cable (optional)	12		
5.2.3. Earthing	12	Appendix A - EC Declaration of Conformity	41
5.2.4. Required nominal input voltage at charge point	12		
5.2.5. Electrical protection	12	Appendix B - EC Declaration of Conformity - Cable	42

1. Preface

1.1. Original instructions

This manual has been translated into multiple languages. The original manual is written in UK English. All other language versions are translations of the original manual.

1.2. Copyright

The content of this manual is protected by copyright and other intellectual property laws. The content of this manual may only be copied, modified, reproduced, translated with express written permission from The NewMotion B.V. This manual may only be published, transmitted, displayed or made available to a third party with express written permission from The NewMotion B.V.

1.3. Disclaimer of liability

This manual is created for you with care.

We, however, do not guarantee that all information is complete, accurate and correct. Please check our website <https://newmotion.com> for the latest version of this manual. Our product must be installed by certified professionals. How our product should be installed and used depends on local circumstances and local and national regulation, which are not mentioned in our manual. NewMotion is not responsible for any loss or damage whatsoever caused – including without limitation, any indirect, personal or consequential loss or damage - arising from or in connection with the use of this manual. Nor does NewMotion accept any liability for any such loss or damage arising out of your reliance on any information contained in this manual. The manufacturer reserves the right to modify this manual without notification beforehand. If you find any unclarities or mistakes in this installation manual, or if you have any feedback or suggestions in general about this manual, please inform us at installationmanualfeedback@newmotion.com and mention the document version in the subject.

1.4. About this document

This manual contains technical descriptions and instructions for the following product:

Category of product	EVSE compatible with IEC 61851 Mode 3
Product name	Home Advanced 2.1 Home Advanced 2.2 Home Advanced 2.1 Cable Home Advanced 2.2 Cable

This manual contains all instructions and safety information for installation and commissioning of the product.

This manual is intended for the qualified technician that installs the product.

1.5. Used symbols in this document

This manual contains safety warnings that may result in injury when ignored. Each safety warning is indicated with a signal word. The signal word corresponds with the level of risk of the described hazardous situation.

▲ WARNING	Indicates that serious injury that may possibly lead to death can be sustained or that the product can suffer serious damage if the instruction is not followed correctly.
▲ CAUTION	Indicates that minor to moderate injuries may be sustained or that the product may suffer damage if the instruction is not followed correctly.
NOTICE	Indicates that there is additional emphasis on the instruction, without direct risk for injury or damages.

1.6. Used abbreviations / terminology in this document

AC supply	Alternating current supply. Electrical device that supplies electric power to an electrical load, delivered by alternating current
cm	Centimeter
Consumer unit	A distribution board designed for domestic installations
dBm	Decibel
DC	Direct current

DHCP	Dynamic Host Configuration Protocol
DIN-rail	A DIN rail is a metal rail of a standard type widely used for mounting circuit breakers and industrial control equipment inside consumer units or distribution boards.
Distribution board	A component of an electricity supply system that divides an electrical power feed into subsidiary circuits, while providing a protective fuse or circuit breaker for each circuit in a common enclosure (source: Wikipedia)
DPM	Dynamic Power Management
(D)SMR	(Dutch) Smart Meter Requirements
Electricity grid	An interconnected network for delivering electricity from producers to consumers
EV	Electric vehicle
EVSE	Electric vehicle supply equipment
EV-Ready	Born under the lead of automobile manufacturers Renault-Nissan EV-Ready mark is the result of a technical quality work done at numerous workshops with representatives of the all the players in this industry
GND	Ground
GPRS	General Packet Radio Service
H x W x D	Height x Width x Depth
hPa	The abbreviated name for hectopascal (100 x 1 pascal) pressure units which are exactly equal to millibar pressure unit (mb or mbar)
IEC	International Electrotechnical Commission
kg	Kilogram
kW	Kilowatt
LED	Light-emitting diode
mA	Milliampere
MCB	Miniature circuit breaker. Can break a low voltage electrical circuit, in order to protect against overloading or short-circuiting.
MID certified	Measuring instruments directive certified. Required for energy meters that are used for billing purposes
mm	Millimeter
NFC	Near-field-communication
Nm	Newton meter
OCPP	Open charge point protocol
PCB	Printed circuit board
RCBO	Residual circuit breaker with overcurrent protection. Protects an electrical installation against both excessive leakage currents and overcurrents caused by overloading or short-circuiting.
RCD	Residual current device. Monitors an electrical installation to detect any leaking current caused by overloading or short-circuiting.
RFID	Radio-frequency identification
TCP	Transmission control protocol
UTP	Unshielded twisted pair
V	Volt
W	Watt
ZE-Ready	ZE Ready is a mark registered by Renault. You can find all the information on the ASEFA and LCIE websites

2. Safety

2.1. Introduction

Observe the instructions in this manual before you start working with the product. If you fail to follow the instructions from this manual you can put yourself and others in danger.

Always comply with the information, such as labels and the nameplate, attached directly to the product and keep the information in a legible condition.

Always comply with any applicable laws and regulations that have not been accounted for in this manual.

2.2. Intended use and reasonably foreseeable misuse

Home Advanced 2.1 / 2.2 is a charge point intended for charging electrical vehicles compatible with IEC-61851 Mode 3 definition and requirements. Electrical vehicles and cables used with this charge point should always be undamaged and in their original state.

The product must only be operated within its performance limits and under the permitted ambient conditions, see chapter 3.3. Technical specifications.

The following is considered foreseeable misuse:

- use of adaptors, conversion adaptors or extension sets for cables.
- use in an environment that varies from or exceeds the given environmental conditions.
- use that varies from or exceeds the given operating conditions.
- failure to comply with the instructions in this manual.
- failure to eliminate faults, malfunctions or defects of the product that impose safety risks.
- unauthorized removal or modification of parts or safety devices of the product.
- use of spare parts or accessories that have not been approved by the manufacturer.
- operation in a flammable and/or explosive environment.



2.3. Qualification of installer

Only authorised technicians are allowed to perform installation and maintenance of the product. They must possess the following qualifications:

- are familiar and abide by the safety instructions and sections of this manual related to installation of the product;
- are familiar with and abide by the applicable local, national and international laws and regulations;
- are able to recognize the possible dangers of the product and take the necessary measures to protect persons and property.

2.4. Protective measures

2.4.1. Personal protective equipment (PPE)

	Wear insulating gloves while installing wires and electrical components to avoid damages from static discharge.
	Wear S3 class antistatic safety shoes.
	Wear safety goggles/glasses while drilling holes to protect your eyes from dust or other particles that may damage your eyes.

2.5. Residual risks

Despite the safe design and construction of the product and the prescribed protective measures, the product possesses residual risks. This manual provides safety messages to indicate these risks. The formatting and appearance of safety messages that are dedicated to a particular section or sentence is explained in chapter 1. Preface. For the overall safety messages see chapter 2.7. Safety precautions.

2.6. How to handle in case of an emergency

Immediately cut power to the circuit on which the charge point has been installed in case of an emergency.

2.7. Safety precautions

2.7.1. Electricity

▲ WARNING

- Always cut the power to the circuit before installing the product.
- The electrical system must be voltage-free during the entire installation procedure. Failing to do so can lead to serious injury or even death.
- The installation procedure must be carried out by a trained electrician who works in accordance with all relevant local laws and regulations.
- Do not install in potentially explosive atmospheres and/or zones with high electromagnetic radiation and/or in flood-prone areas.
- The charge point is connected to the electricity grid and even if the equipment is switched off, hazardous voltages may be present at the input terminals.
- Always switch off the AC supply before starting any work on the charge point and/or its installation. Do not carry out any work in rainy conditions or when the humidity is above 95%.
- The safety guidelines are intended to ensure correct installation and usage. Any failure to comply with the valid safety guidelines or instructions provided in this manual may result in fire, electrocution or severe injury.
- The charge point is a product in safety class I and is supplied with an earth terminal for protection purposes.
- The AC input terminal blocks must be fitted with an uninterruptible earth for protection purposes. Ensure that the connection cables are fitted with fuses and circuit breakers.
- Never replace a protection component with another type that decreases the safety level. First check the full installation to determine if that component can be used with the existing installation components.
- Before you switch on the charge point, check that the available power source matches the configuration settings of the product, as described in this manual.
- Tripping of the MCB, RCD or RCBO could be caused by an earth fault, leakage or a defect contactor. If, after resetting the MCB, RCD or RCBO, the device cannot be activated or immediately trips again; please contact NewMotion or your installer.

2.8. Labels

The warning labels and information signs on the product must be followed. The warning labels and information signs must be kept legible and must be replaced if necessary. For this purpose, contact the manufacturer.

3. Description of the product

3.1. Main parts

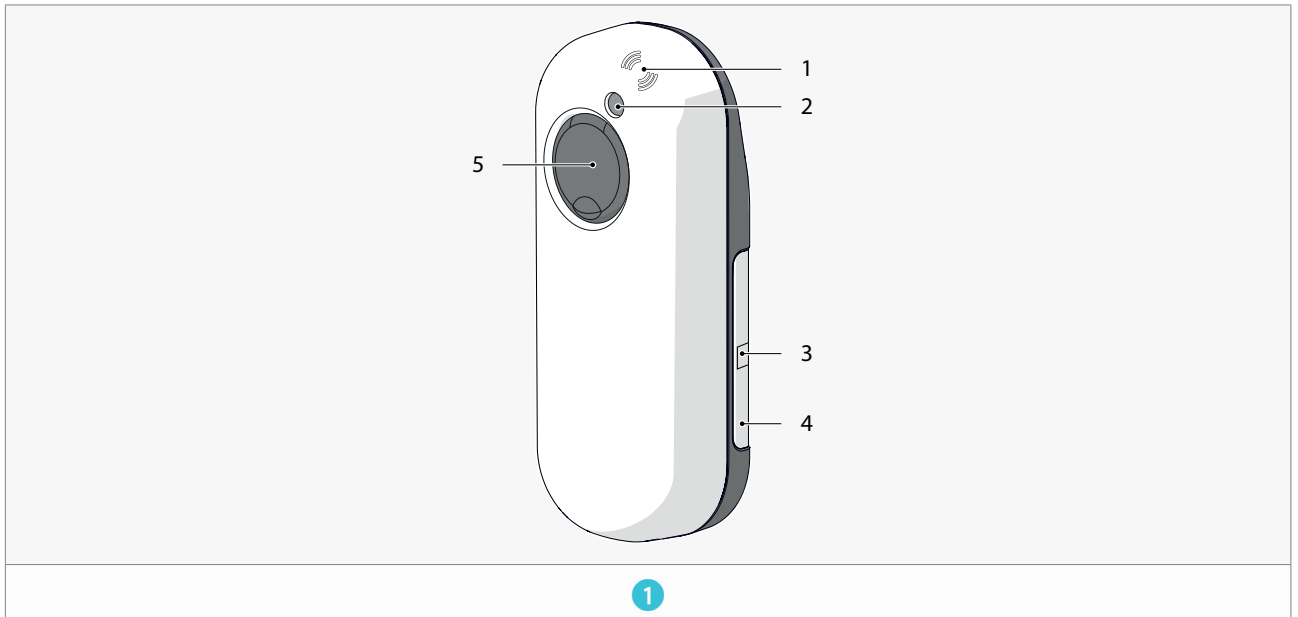

- 1. RFID reader
- 2. LED status indicator
- 3. Identification label with serial number
- 4. Product details
- 5. Type 2 EV plug socket and cover lid, or dummy socket for tethered cable

3.2. Internal connections

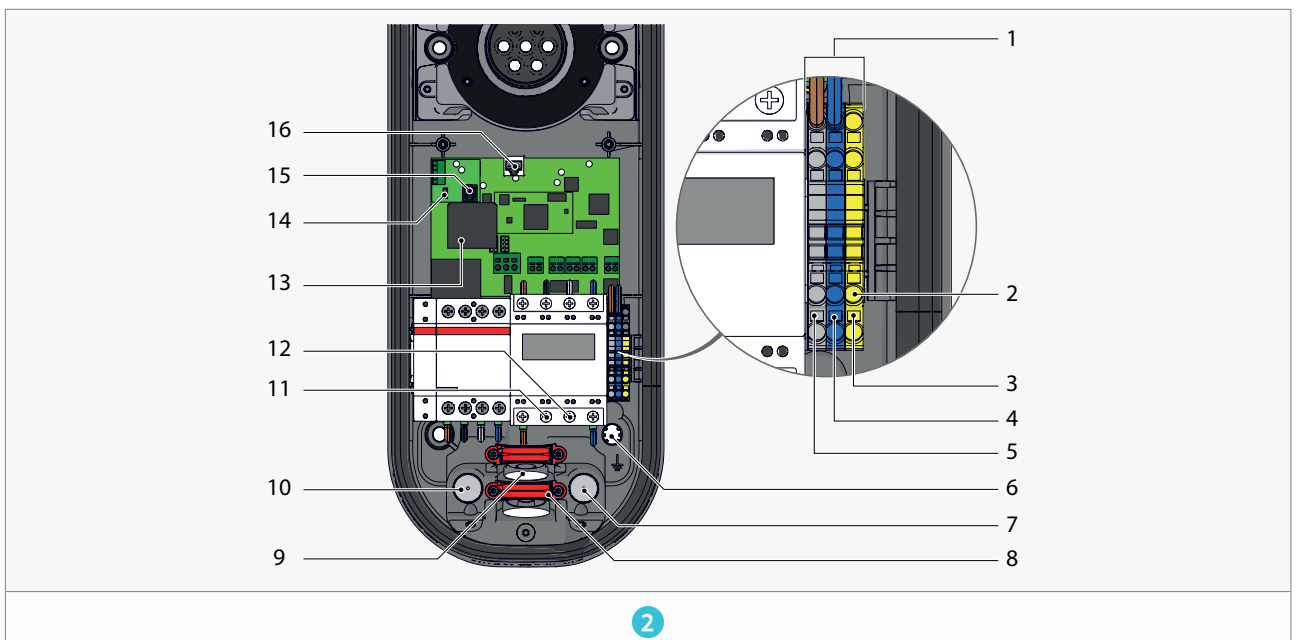

- 1. Terminal blocks
- 2. Earthing point for pole mount
- 3. Earth connection
- 4. Neutral connection
- 5. Phase 1 connection
- 6. Earthing pole
- 7. Data cable inlet with grey rubber rommet
- 8. Power cable clamps
- 9. Inlet for power cable
- 10. Data cable inlet with grey rubber rommet
- 11. Phase 2 connection
- 12. Phase 3 connection
- 13. DC fault detection module
- 14. Connection DC fault detection module
- 15. P1 port (DPM module)
- 16. Ethernet port

3.2.1. Internal connections for tethered cable

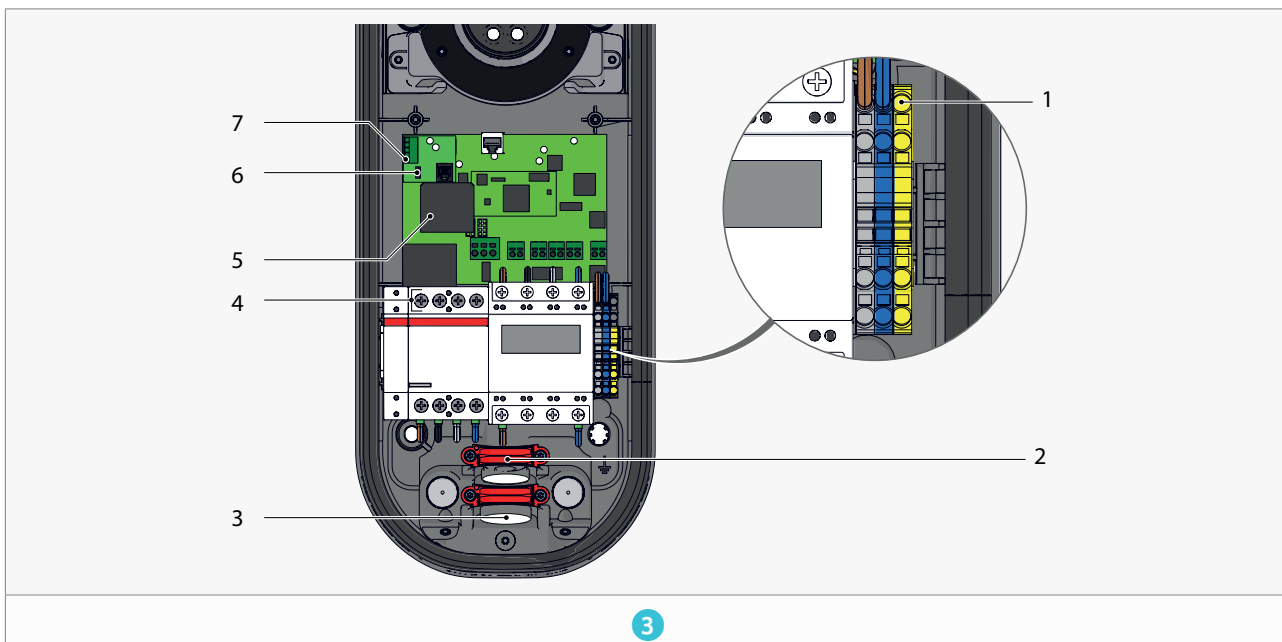

- 1. Earthing tethered cable
- 2. Cable clamp
- 3. Tethered cable inlet
- 4. Tethered cable connection. Keep the same order as the connection under contactor
L1 = portal 1
L2 = portal 2
L3 = portal 5
Neutral = portal 7
- 5. DC fault detection module
- 6. Connection DC fault detection module
- 7. Connector for communication with the car to red wire

3.3. Technical specifications

Maximum charge capacity	1-phase 32 A (7,4 kW)* 3-phase 32 A (22 kW)*
Factory configured charge capacity	1-phase 16 A (3,7 kW)** 3-phase 16 A (11 kW)**
Fail-safe current during data connection failure	8 A per phase
Electric safety category	Class I
DC fault current protection	Built-in 6 mA fault current protection (≤ 10 sec.)
Dimensions (H x W x D)	503.5 x 200 x 137 mm
Weight	± 4.0 kg
IEC-62262 IK code (robustness)	IK10
IEC-60529 IP code (protection class)	IP54 (for indoor and outdoor use)
Certificates	IEC-61851-1 IEC-61851-22 EV-Ready 1.4 G & ZE-Ready 1.4 G IEC-62262 -> IK10 IEC-60529 -> IP54 IEC-62955 -> 6 mA DC fault protection

kWh measurement	MID certified
A-weighted emission sound pressure level	<70 dB(A)
User interface	LED
Identification	RFID (NFC) Mifare 13.56 MHz IEC 14443A IEC 14443B Plug & charge (through online portal)
Communication backoffice 2.1	GPRS 2G (minimal -80 dBm Vodafone partners) Ethernet connection CAT5/CAT6 (DHCP, TCP 443, TCP80, TCP21) GPRS 2/3/4G with mobile router***
Communication backoffice 2.2	GPRS 2G / 4G LTE Cat 1 (minimal -80 dBm Vodafone partners) Ethernet connection CAT5/CAT6 (DHCP, TCP 443, TCP80, TCP21) GPRS 2/3/4G with mobile router***
Communication Smart Meter	Straight RJ12 (6P6C) wired CAT5 (max 20 m) - DSMR > 4.0
Backoffice protocol	OCPP protocol
Stand-by consumption	3-5 W
Operating temperature range	-30 °C to +50 °C
Operating humidity range	5% to 95%
Operating air pressure range	860 hPa to 1060 hPa
Maximum socket mounting height	1.5 meter above ground
Advised socket mounting height	1 meter above ground
Mounting orientation	Vertical and upright position only
Function for ventilation according to IEC-61851	Not supported
Maximum length of tethered cable	8 meters
Thickness of tethered cable	16 mm

* *The maximum charge capacity of the charge point depends on several factors. This includes; local rules & regulations, the type of EV, the grid connection at your location and the electricity usage of your building*

** *Contact NewMotion for changing charge capacity*

*** *Contact NewMotion for further information: +44 20 3868 1036 and press option 1*

3.4. Nameplate / markings

The product is marked in accordance with the applicable legislation requirements (see figure 4). The nameplate/markings is located on the right side of the product.

See figure 2

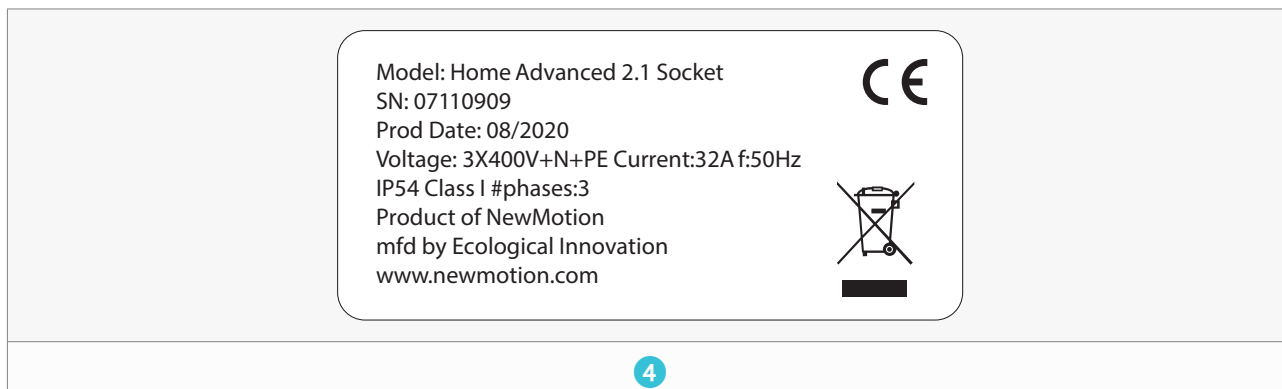

4. Transport and storage

4.1. Transport

Do not drop the product and avoid bumping when transporting the product. Excessive vibrations during transport can lead to loosened connections and can influence proper functioning of the product.

4.2. Storage

Disconnect the product from the power supply when storing the product.

Always store the product in environmental conditions that fall within the ranges as stated in chapter 3.3. Technical specifications. Place the product back in the shipping box or cover the product to minimize exposure to dust, moist and protect it from damages.

5. Installation

5.1. Scope of delivery/Check the contents

5.1.1. Home Advanced 2.1 / 2.2

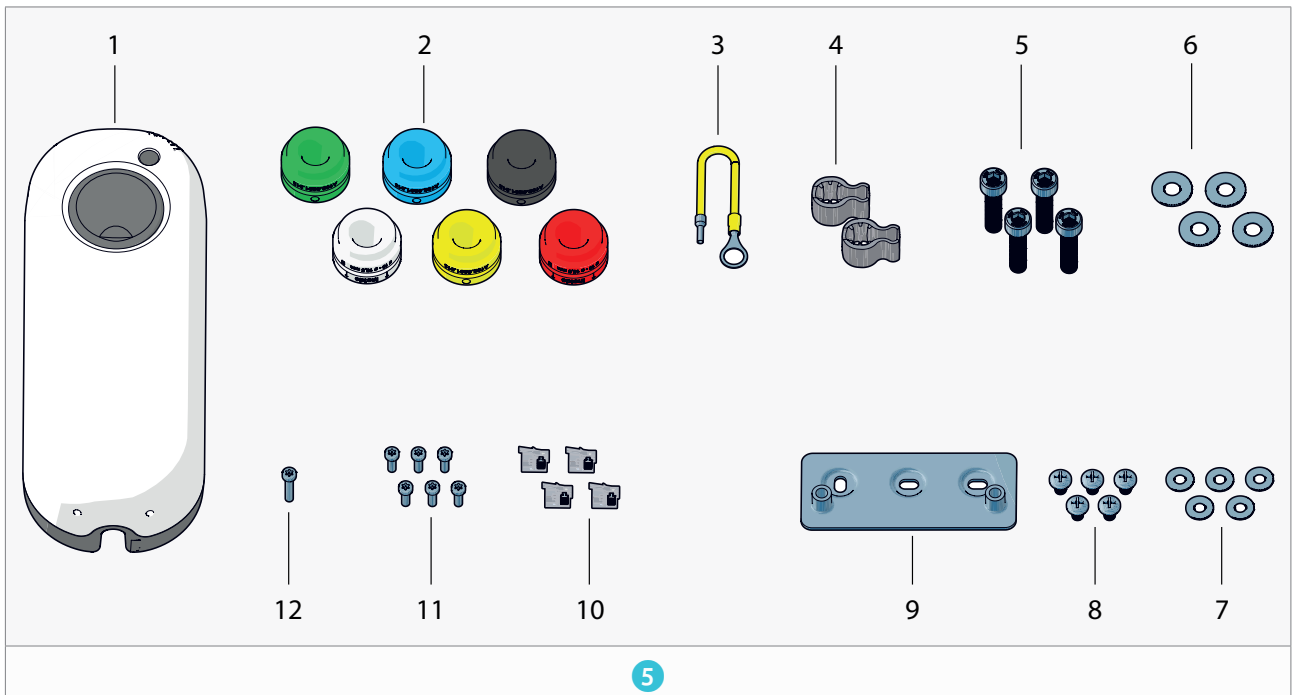

- 1. Charge point (1x)
- 2. Coloured grommet 10 - 22.5 mm (6x)
- 3. Earthing wire (1x)
- 4. Plastic spacer (2x)
- 5. M8 x 35 mm Allen bolt (4x)
- 6. M8 washer - big (4x)
- 7. M8 washer - small (5x)
- 8. M8 x 12 mm PZ3 head bolt (5x)
- 9. Wall mounting bracket (1x)
For wall mount (use only if applicable)
- 10. M4 x 12 mm Torx bolt (6x)
- 11. M4 x 20 mm Torx bolt (1x)
- 12. RJ12 unshielded connector (4x)

5.1.2. Optional

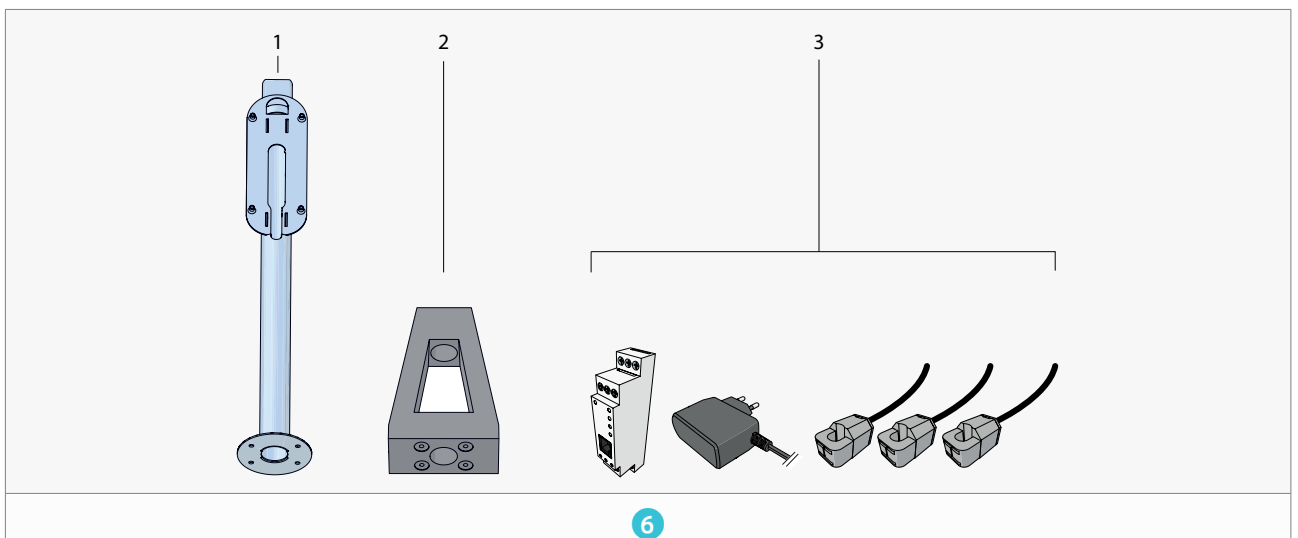

- 1. Mounting pole
- 2. Concrete base
- 3. DPM module

5.2. Installation materials (not provided)

5.2.1. Power cable

The electrician is responsible for selecting the power cable type and size & safety components appropriate for the specific situation and according to local regulations;

- Wire for the current at the maximum charging speed of the charge point under continuous load;
- Calculate with a power factor of 0.8;
- Calculate with a maximum voltage drop according to the local rules & regulations;
- Use shielded cable for underground cabling;
- Cable thickness: Ø 10 - 22.5 mm;
- Wire cross section
 - Solid wires: max. 10 mm²;
 - Stranded wires: 6 mm² with end ferrules.

NOTICE The charge point can be limited between 6 A and 32 A, as described in chapter 6.3. Switching on the product.

5.2.2. Data cable (optional)

Ethernet cable: Standard CAT5 or CAT6 UTP ground cable with T568B-wired RJ45 connectors;

DPM data cable: Standard CAT5 UTP ground cable with straight-wired RJ12 connectors (connectors provided).

5.2.3. Earthing

The electrician is always responsible for selecting a cable cross-section appropriate for the specific situation and according to regulations;

- TN-system: PE-cable (PEN conductor is not allowed);
- TT-system: separately installed earthing electrode < 100 Ohm spreading resistance.

5.2.4. Required nominal input voltage at charge point

- Single phase*: 230 V ± 10 % - 50 Hz
- Triple phase*: 400 V (3 × 230 V + N) ± 10% - 50 Hz

* 3-phase charge point can also be connected to a 1-phase installation. In this case the charge point can only charge on 1-phase. Only connect L1 on the terminal block of the charge point;

5.2.5. Electrical protection

- MCB: C-characteristic*;
- RCD: According to IEC 60364-7-722:2015 this charge point must be installed with at least an RCD type A**
- RCBO: with overcurrent- and residual-current detection as described above.

722.531.2.101 Except for circuits using the protective measure of electrical separation, each connecting point shall be protected by its own RCD of at least type A, having a rated residual operating current not exceeding 30 mA.

Where the EV charging station is equipped with a socket-outlet or vehicle connector complying with the IEC 62196 series, protective measures against DC fault current shall be taken, except where provided by the EV charging station.

The appropriate measures, for each connection point, shall be as follows:

- RCD type B; or
- RCD type A and appropriate equipment that ensures disconnection of the supply in case of DC fault current above 6 mA.

RCDs shall comply with one of the following standards: IEC 61008-1, IEC 61009-1, IEC 60947-2 or IEC 62423.

NOTICE The charge point is supplied with a DC fault detection device certified according to IEC 62955.

* The installer must select a suitable MCB to match the current setting of the charge point, taking into

account MCB manufacturer specifications and EV-Ready guidelines;

** The electrician is responsible to select a suitable RCD to match the local rules and regulations. Please note that these may be different from the international rules and regulations.

NOTICE The charge point can be limited between 6 A and 32 A, as described in chapter 6.3. Switching on the product.











5.2.6. Charge point mounting







For wall mounting, use 5 × coach screws (6.3 × 70 mm), washers and plugs.

For pole mounting on a concrete base, use fill sand to cover the hole of the concrete base for optimal stability.

5.2.7. Installation tools and materials

Make sure to have a basic electricians toolkit when installing a NewMotion charge point.

Icon	Description
	Cabled ethernet connection.
	Data cable tester (RJ12 & RJ45).
	DPM module.
	Fill sand.
	Cellular signal strength measuring tool.
	Pencil.
	Plug for mounting in wall (if applicable).
	Power drill and drill bits.
	PZ3 screwdriver.
	RJ12 crimp tool.

Icon	Description
	RJ45 crimp tool.
	Spirit level.
	Tape measure.
	This is optional.
	Torx screwdriver (T20).
	Voltage tester.
	Caliper.

5.3. Preparation

1. Cut the power to the circuit on which you plan to install the charge point.
2. Prepare the cabling, RCD and MCB according to local rules and regulations. It is also possible to use an RCBO if local rules and regulations allow it.
3. Apply labelling to the used circuit on the consumer unit for future reference.
4. Update the schedule of circuits to include the charge point installation
5. Apply proper lockout-tagout equipment for personal safety.
6. Use a GPRS signal strength measuring tool to determine if the signal is strong enough for network communication via GPRS. The minimum signal strength for a stable connection is -80 dBm.
7. If the signal strength is not strong enough, or if you are not able to measure the signal strength, prepare an Ethernet cable from an internet enabled router to the charge point location.

NOTICE Do not strip or attach a connector to the Ethernet cable on the charge point side yet.

8. Label the Ethernet cable on the charge point side for reference during installation.
9. If you have purchased a DPM module along with the charge point, prepare a DPM data cable from the consumer unit to the charge point location.

NOTICE Do not strip or attach a connector to the DPM data cable on the charge point side yet.

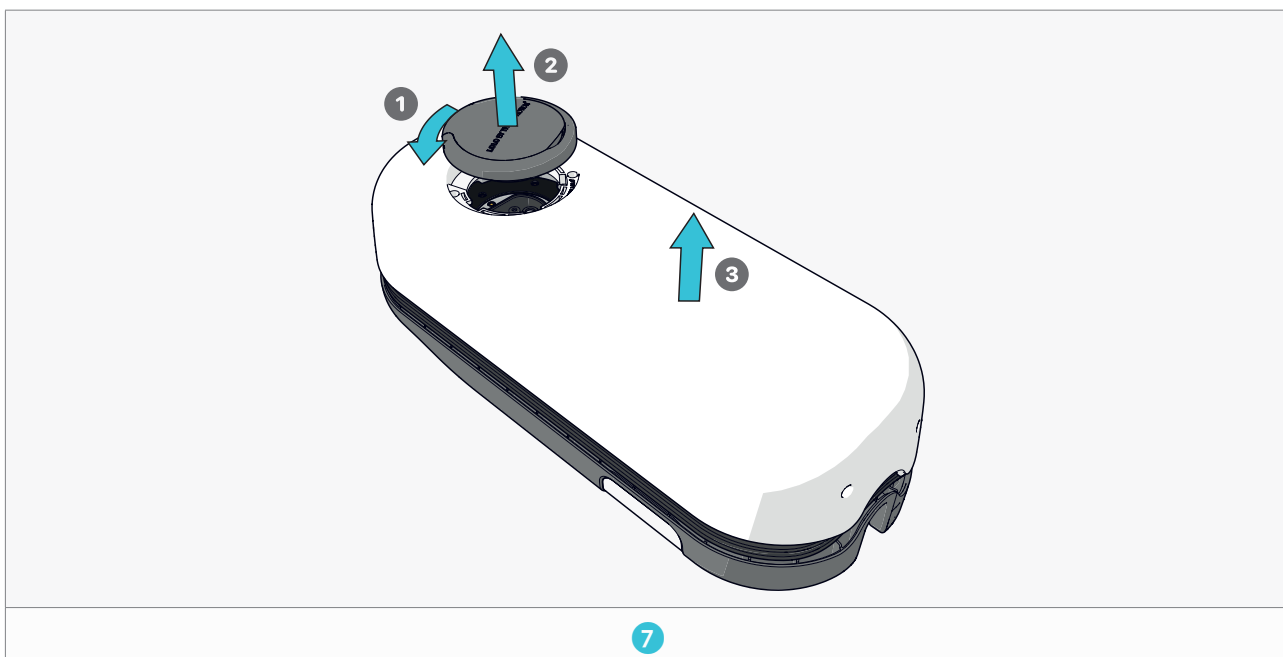

10. Twist the socket lid counterclockwise and pull it from the cover (see figure 7 ① ②).
11. Pull the cover from the casing to open the charge point and access the internal components (see figure 7 ③).
12. Check if all the connected wiring and internal components of the product are properly fastened.

5.4. Mounting

Check the applicable method of installation and continue to the assigned chapter.

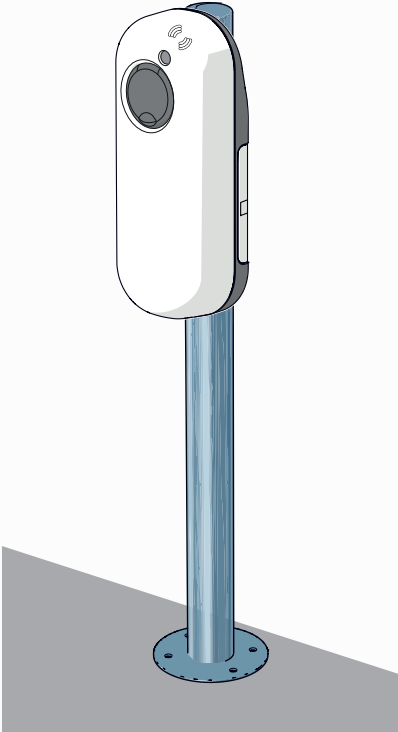
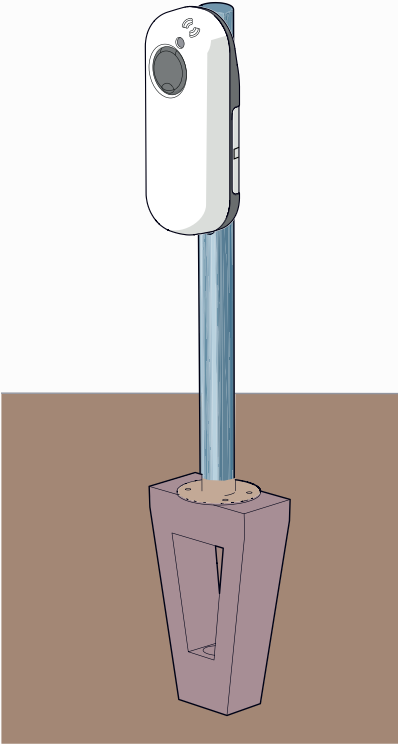
Wall mount	Pavement mount	Soil mount
		
8	9	10
Go to chapter 5.4.1. Wall mount	Go to chapter 5.4.2. Pavement mount	Go to chapter 5.4.3. Soil mount

5.4.1. Wall mount

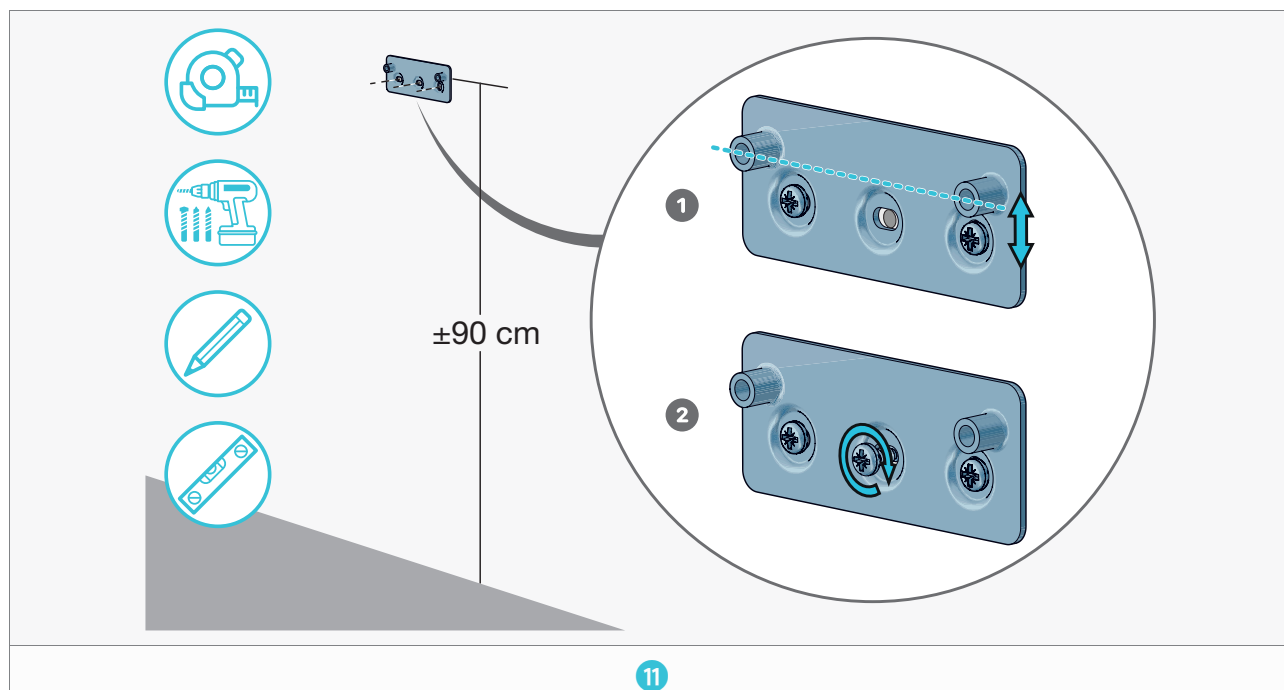

1. Secure the wall bracket to a wall at the appropriate height (± 90 cm) (see figure 11).

NOTICE Make sure the wall is strong enough to withstand the weight of the charge point.

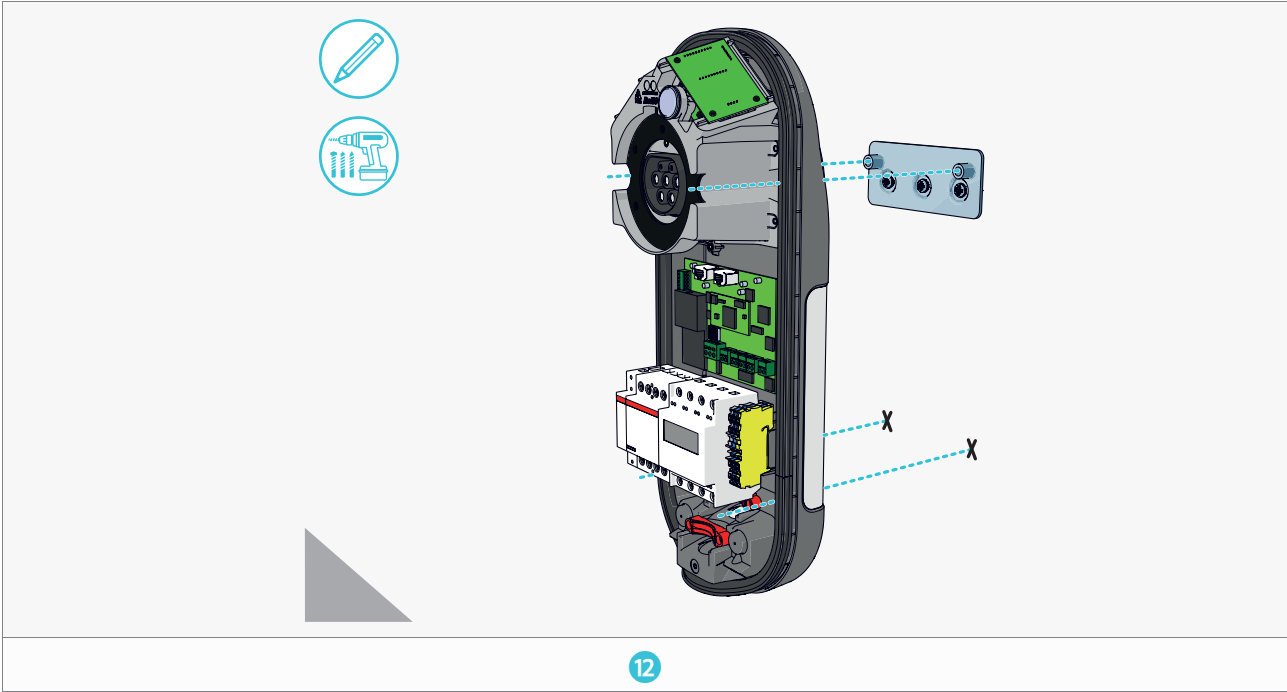

12

2. Place the casing on the wall mount and mark the locations for the bottom fasteners (see figure 12).
3. Remove the casing from the mount and drill two holes for the bottom fasteners.
NOTICE Check the fastener package for the correct diameter and depth.
4. Insert two wall plugs into the holes (if applicable).

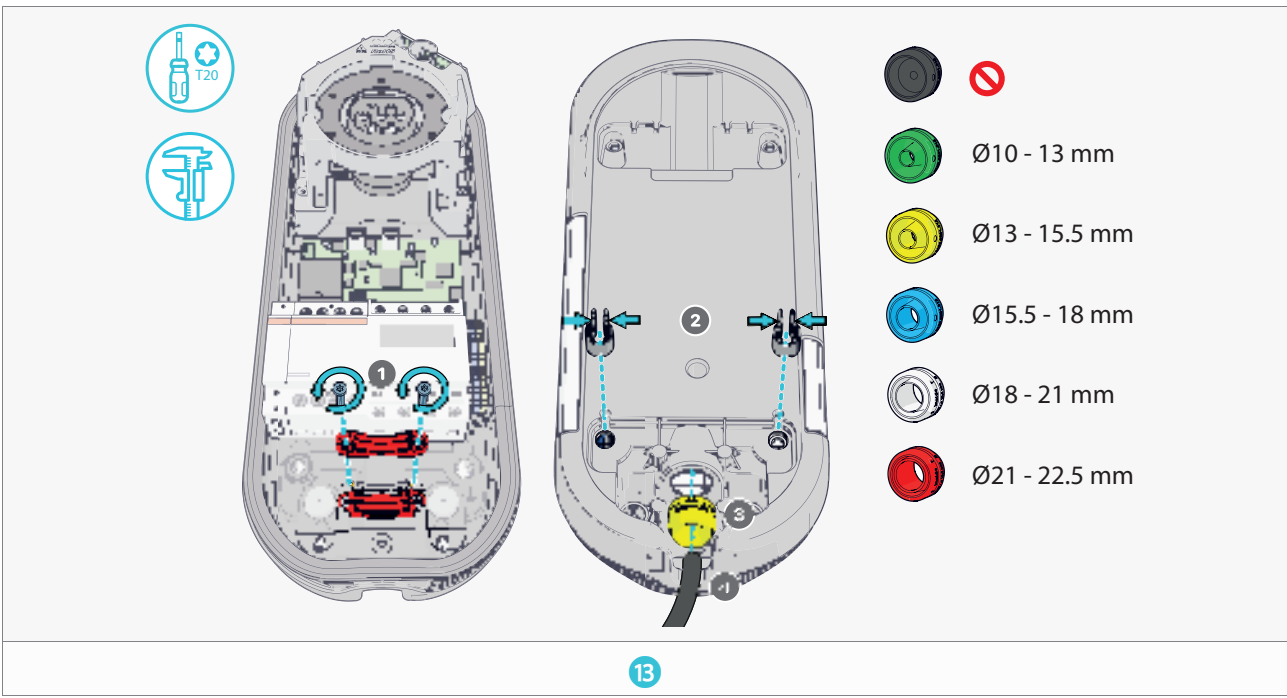

13

5. Remove the rear cable clamp (see figure 13 1).
6. Place the plastic spacers on the back of the casing (see figure 13 2).
7. Insert the coloured grommet matching the power cable thickness into the rear input hole (see figure 13 3).
NOTICE Use a caliper to measure the thickness of the power cable and determine the correct coloured grommet.
8. Feed the power cable approx. 15 cm through the coloured grommet. Lubricate if necessary (see figure 13 4).

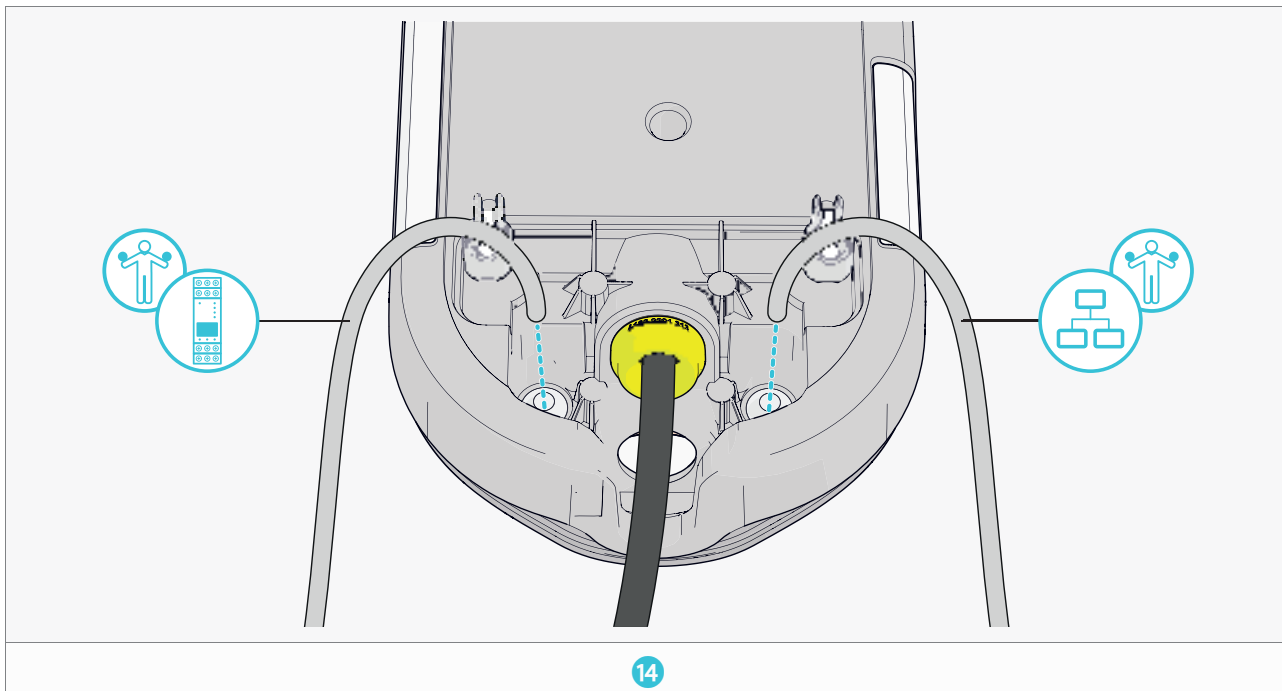

14

The next three steps are **optional** (see figure 14):

9. Punch a hole in the grey grommet(s) for the data cable(s) using a screwdriver.
10. Feed the DPM data cable through the right grommet.
11. Feed the Ethernet cable through the left grommet.

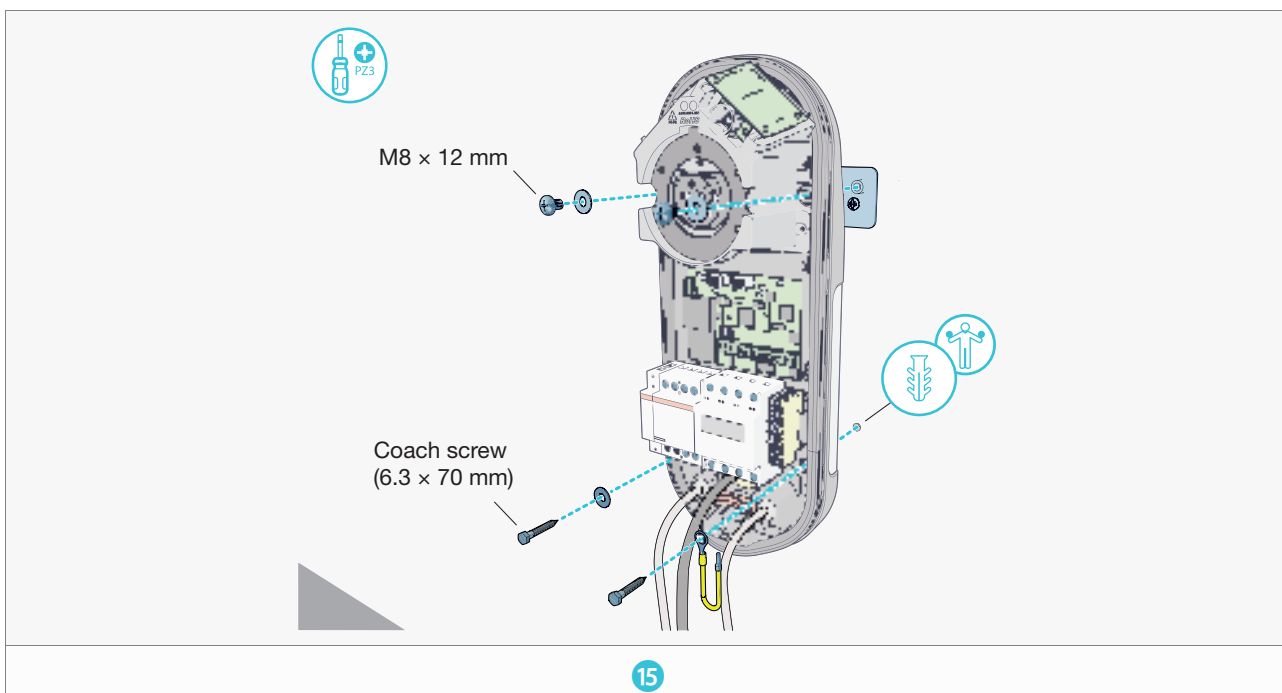

15

12. Secure the casing to the wall using 2 provided M8 × 12 mm bolts, 3 M8 washers and 2 coach screws (not provided) (see figure 15).

NOTICE Secure the supplied earthing cable between the casing and the bottom right screw, if required by local rules and regulations.

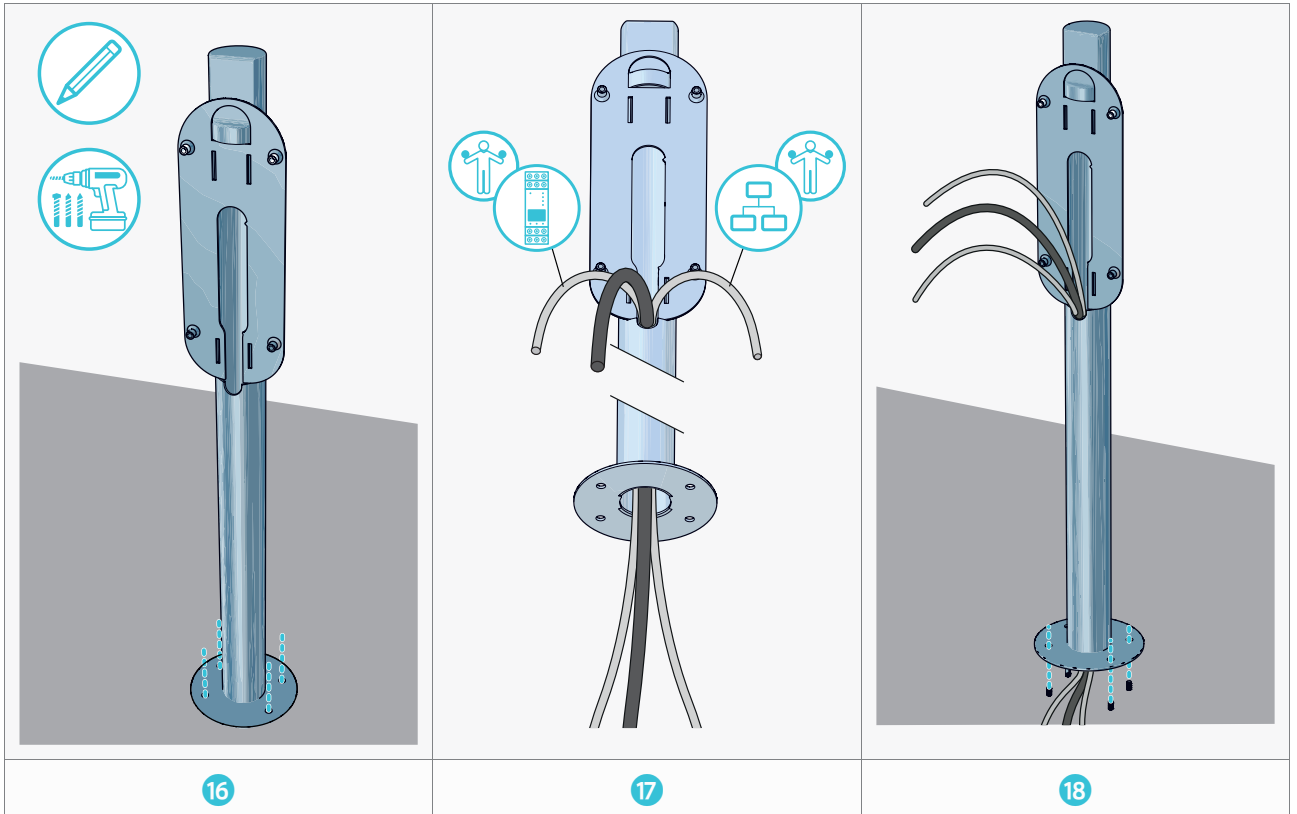

1. Place the pole on the pavement and mark the locations for the holes (see figure 16).
2. Remove the pole and drill holes into the pavement for the wedge bolts or chemical anchors.
NOTICE Check the fastener package for the correct diameter and depth.
3. Secure the fasteners into the holes. Allow the chemical anchor to dry, if applicable.
4. Feed the power cable and **optional** data cable(s) through the pole (see figure 17).
5. Secure the pole to the fasteners using 4 washers and nuts (not provided) (see figure 18).
6. Remove any excess threaded rod, if necessary.

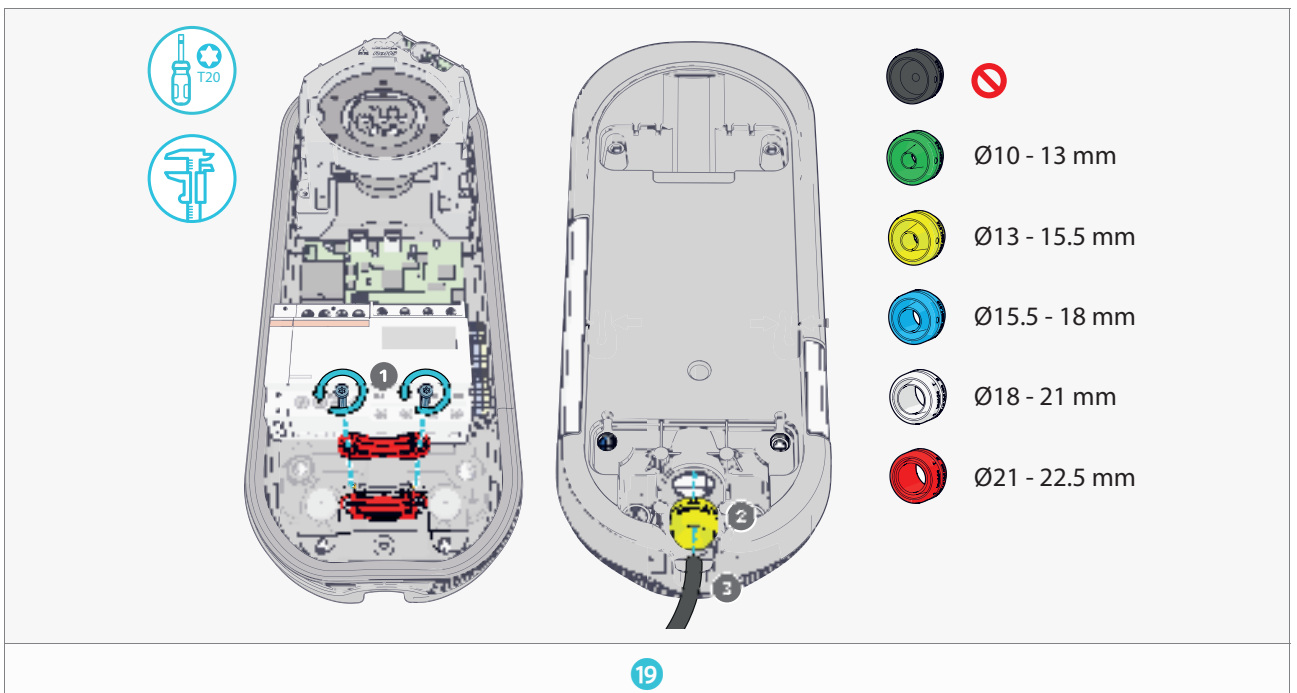

7. Remove the rear cable clamp (see figure 19 1).
8. Insert the coloured grommet matching the power cable thickness into the rear input hole (see figure 19 2).
NOTICE Use a caliper to measure the thickness of the power cable and determine the correct coloured grommet.

9. Feed the power cable approx. 15 cm through the coloured grommet. Lubricate if necessary (see figure 19³).

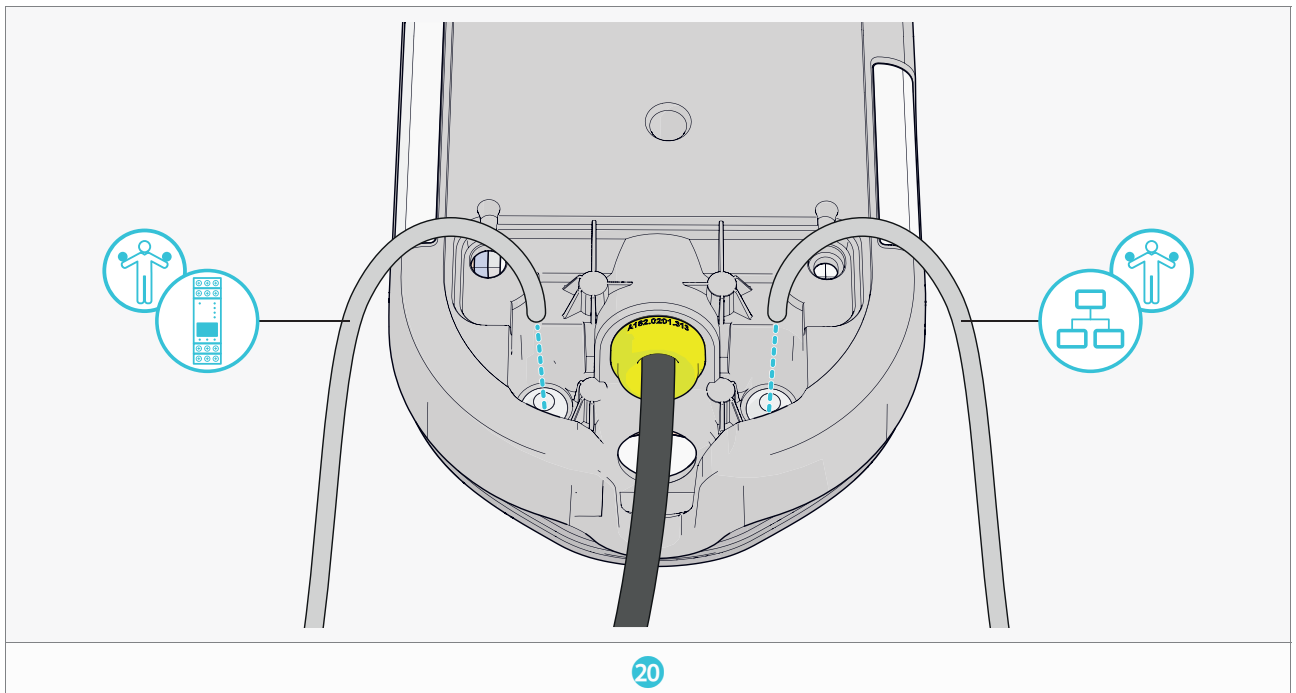

The next three steps are **optional** (see figure 20):

10. Punch a hole in the grey grommet(s) for the data cable(s) using a screwdriver.
11. Feed the DPM data cable through the right grommet.
12. Feed the Ethernet cable through the left grommet.

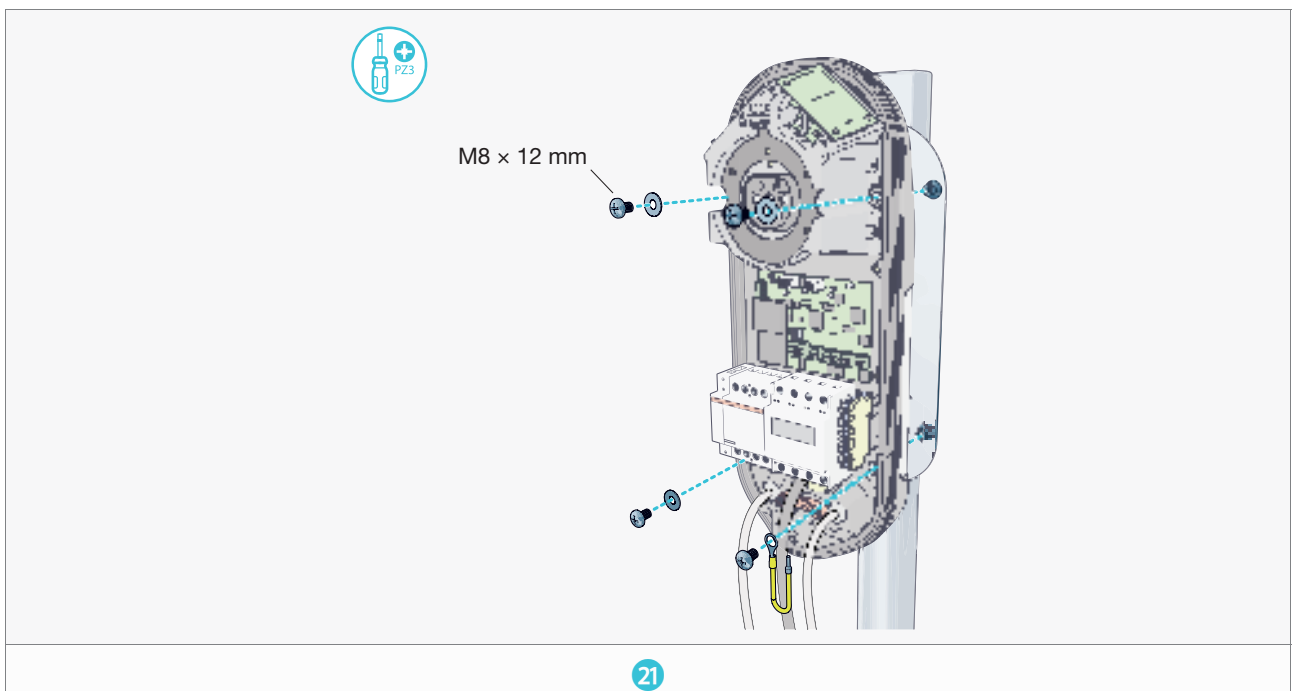

13. Secure the casing to the pole using 4 provided M8 × 12 mm bolts and washers (see figure 21).

NOTICE Secure the supplied earthing cable between the casing and the bottom right screw.

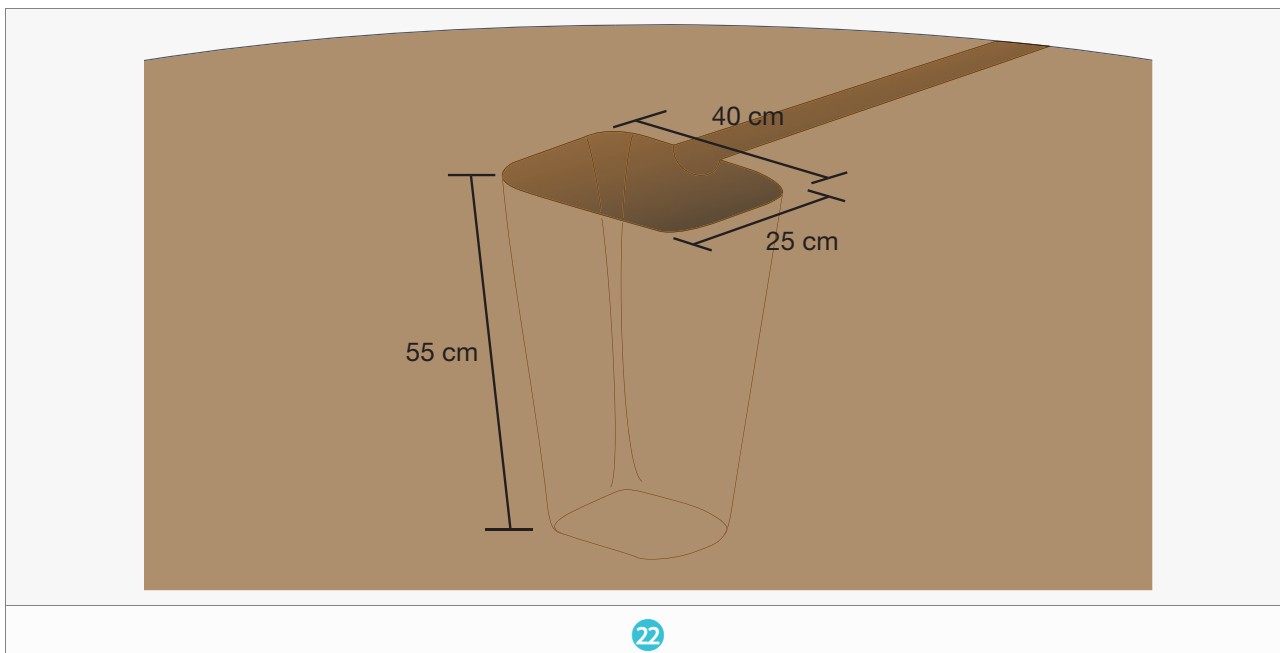

1. Dig a 55 cm deep hole of approx. 25 × 40 cm wide (see figure 22).

NOTICE Do not dig much deeper than necessary, because this will loosen the soil and could decrease stability over the years.

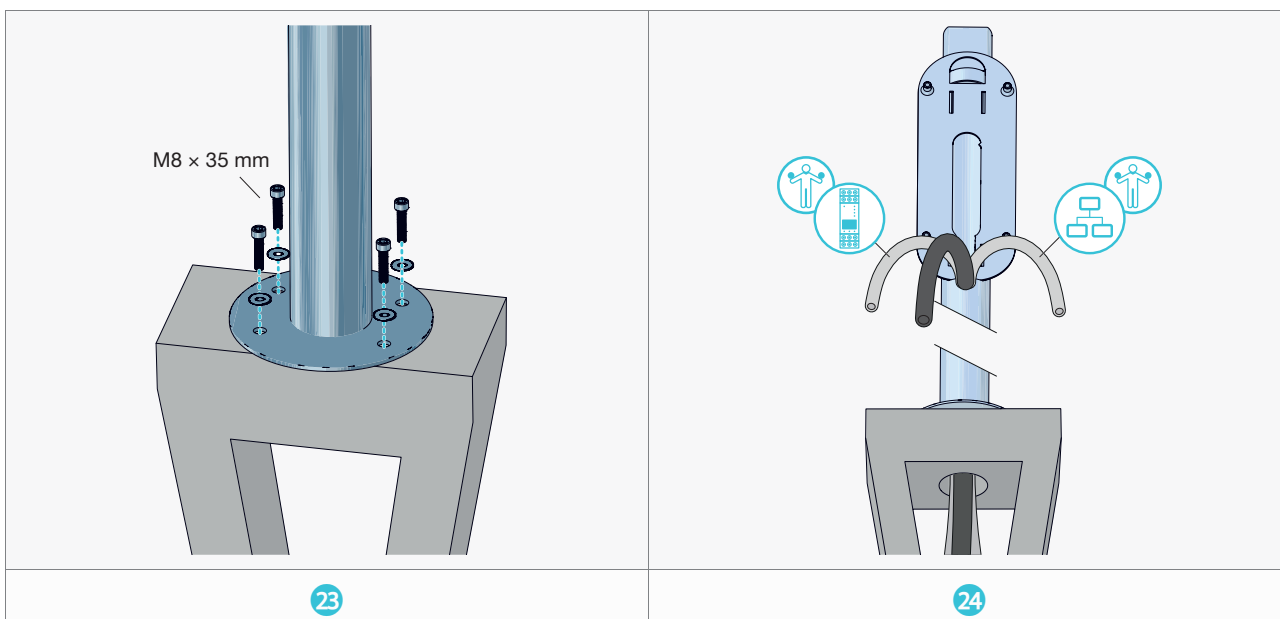

2. Place the pole on the concrete base.
3. Secure the pole to the concrete base using 4 provided M8 × 35 mm Allen bolts and washers (see figure 23).
4. Feed the power cable and optional data cable(s) through the pole (see figure 24).

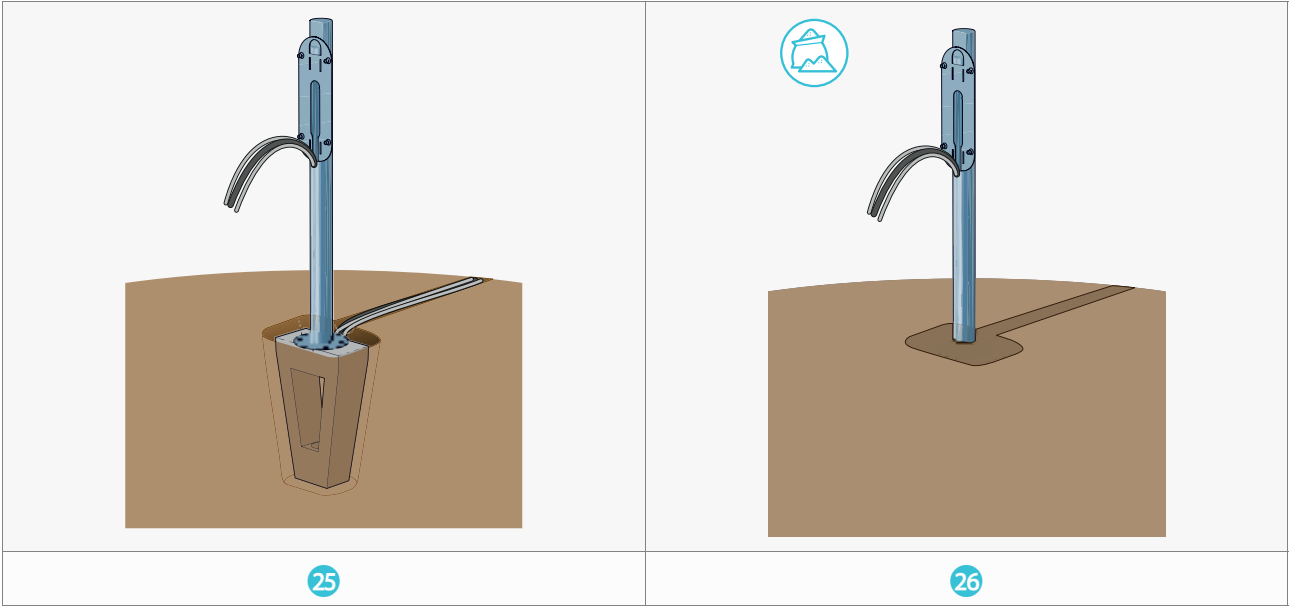

- 5. Place the concrete base into the hole (see figure 25).
NOTICE Ensure there is at least 5 cm distance between the top of the concrete base and the earth surface.
- 6. Fill up the hole with fill sand (not provided) (see figure 26).
NOTICE Make sure the pole is level using a spirit level.
- 7. Pack the sand down around the pole to ensure that the pole remains stable over time.
NOTICE Use a plate compactor to pack the sand down, especially when there have been civil works.

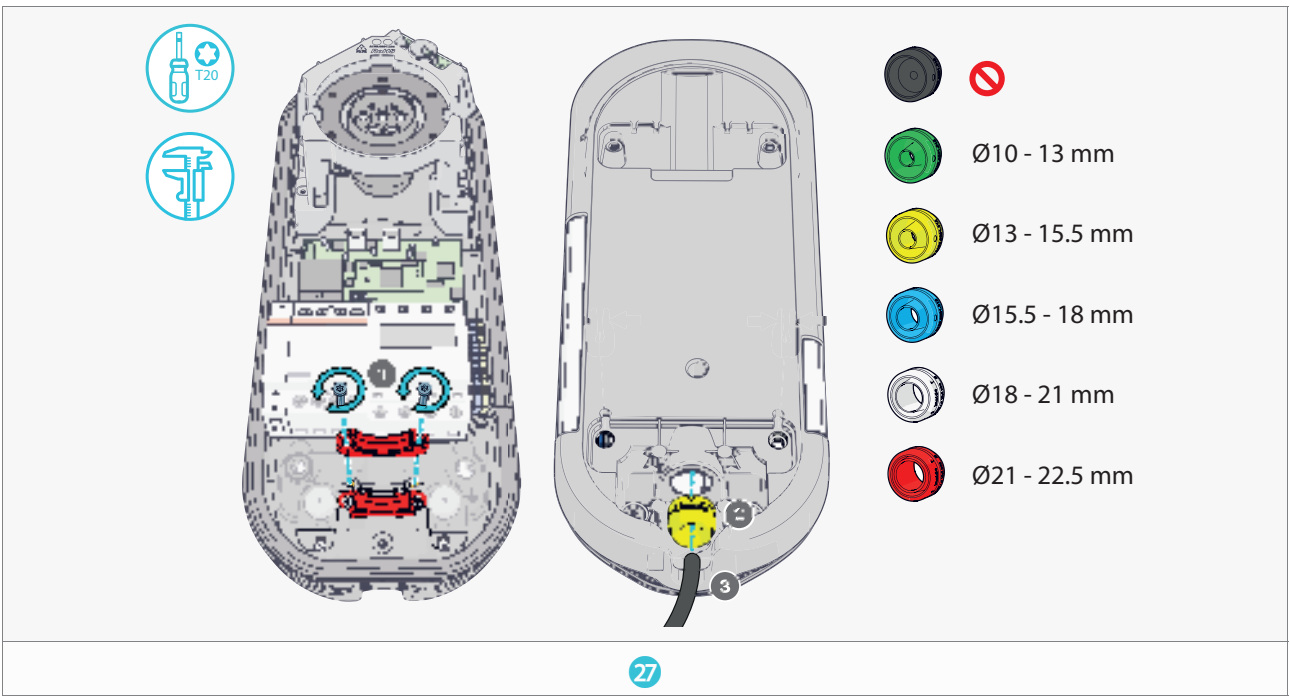

- 8. Remove the rear cable clamp (see figure 27 1).
- 9. Insert the coloured grommet matching the power cable thickness into the rear input hole (see figure 27 2).
NOTICE Use a caliper to measure the thickness of the power cable and determine the correct coloured grommet.
- 10. Feed the power cable approx. 15 cm through the coloured grommet. Lubricate if necessary (see figure 27 3).

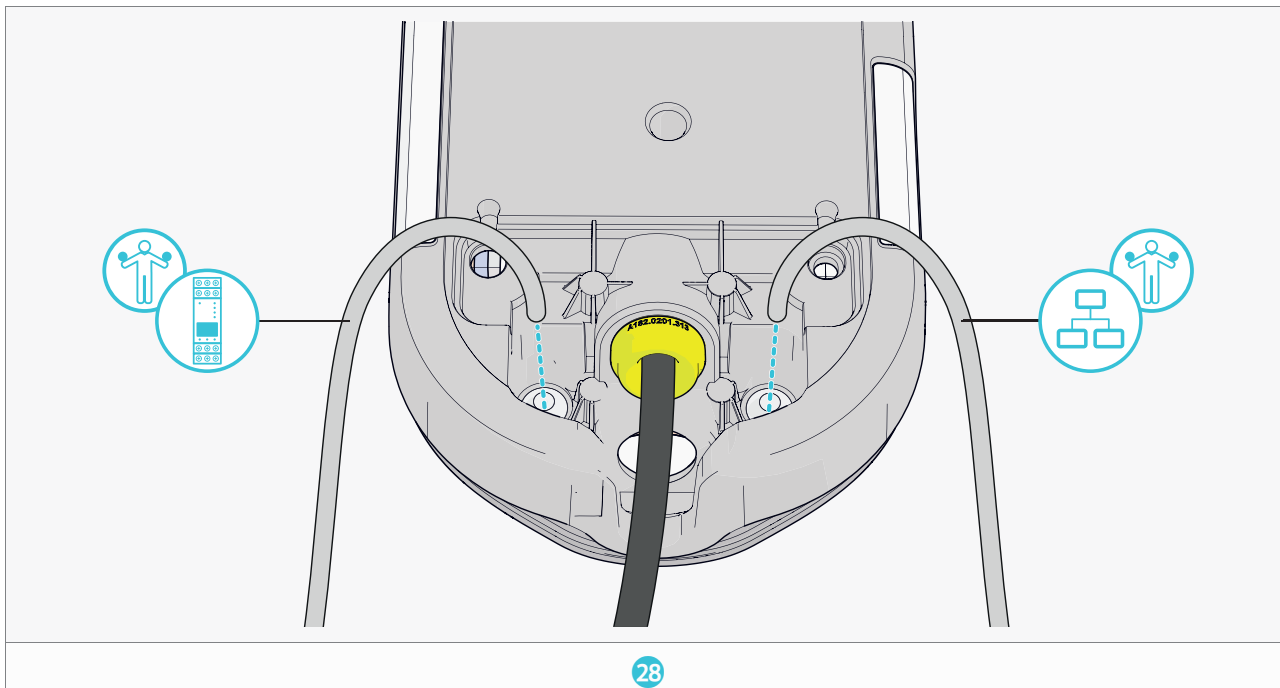

The next three steps are **optional** (see figure 28):

11. Punch a hole in the grey grommet(s) for the data cable(s) using a screwdriver.
12. Feed the DPM data cable through the right grommet.
13. Feed the Ethernet cable through the left grommet.

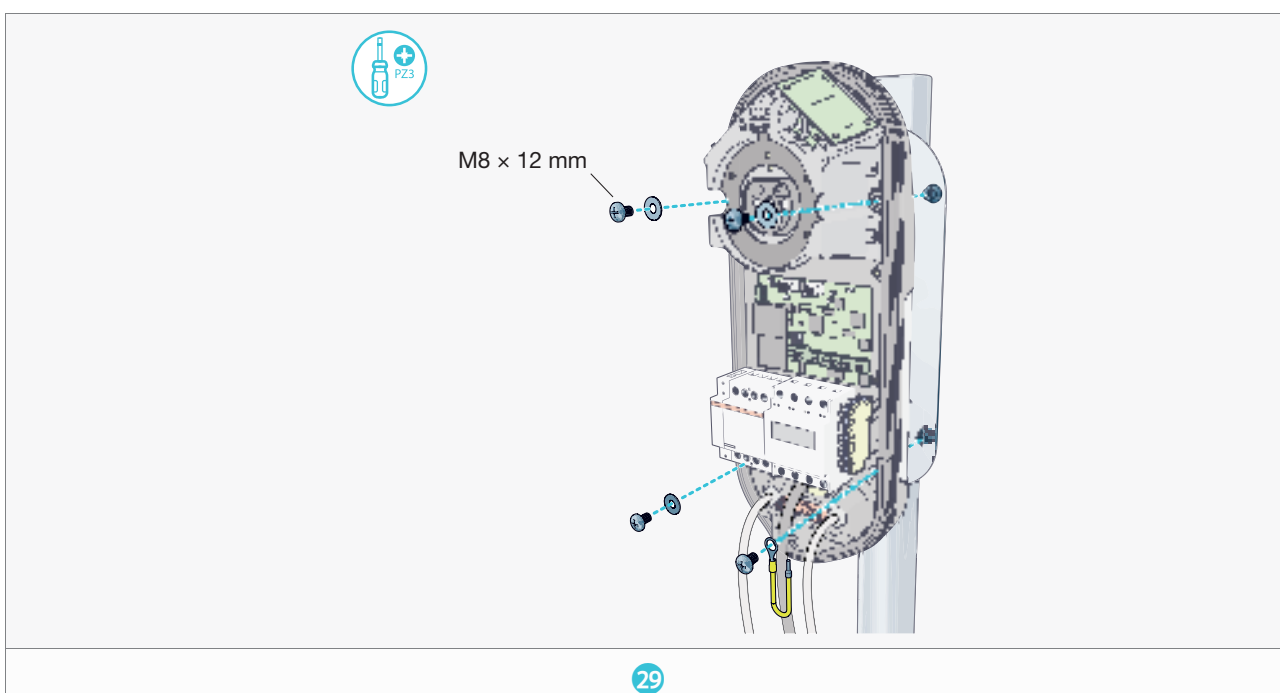

14. Secure the casing to the pole using 4 provided M8 × 12 mm bolts and washers (see figure 29).

NOTICE Secure the supplied earthing wire between the casing and the bottom right screw.

5.5. Electrical connection

5.5.1. Power cable

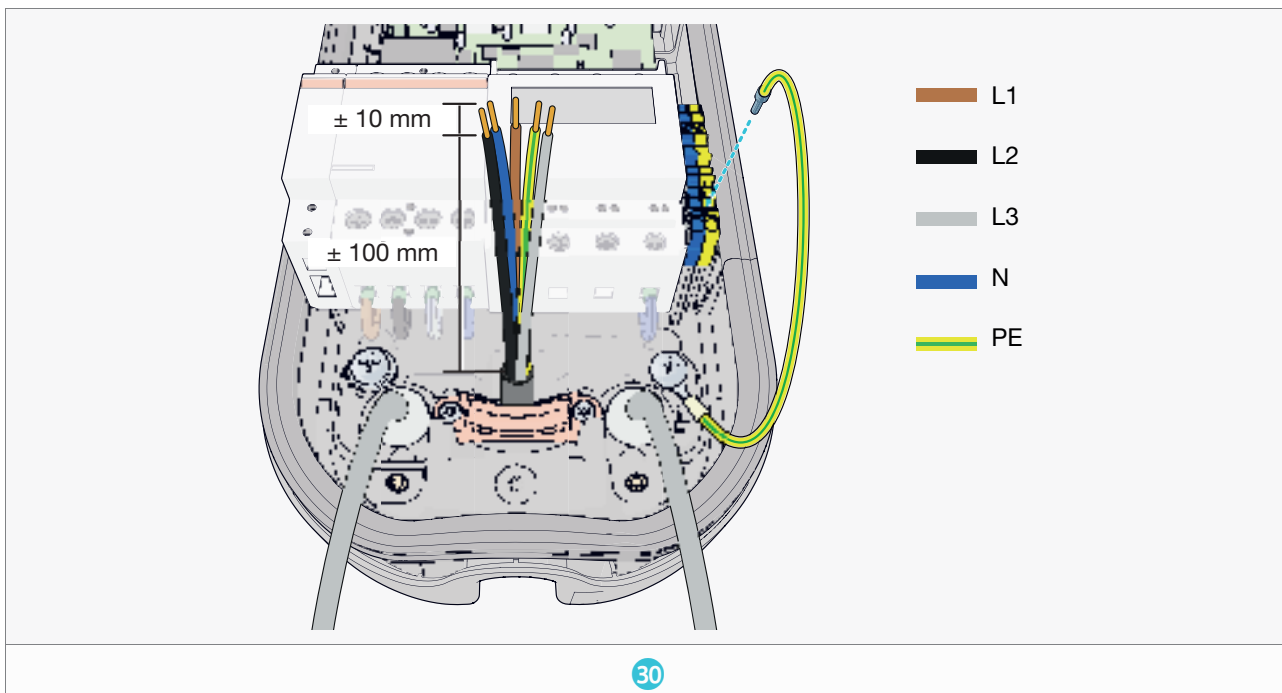

For the next four steps see figure 30.

1. Ensure you have ± 15 cm of free power cable, measured from the inlet grommet.
2. Remove ± 10 cm of the outer insulation from the power cable.
3. Strip ± 1 cm of the insulation from the five wires.
4. Insert the earthing wire into the earth terminal.

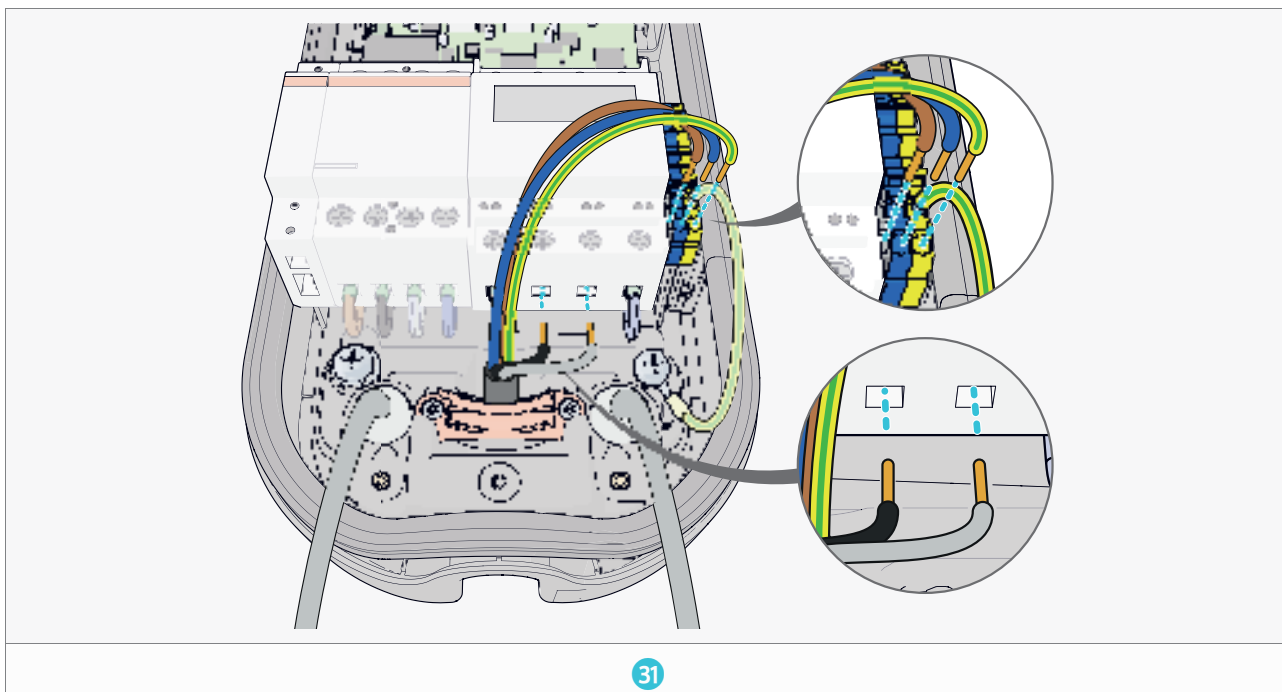

5. Insert the stripped wires into the matching terminals (see figure 31).

NOTICE Cables L2 and L3 are installed directly into the power meter for 3-phase connection only. Apply a torque of 2.4 Nm.

NOTICE The L1 cable must always be connected to the grey terminal block.

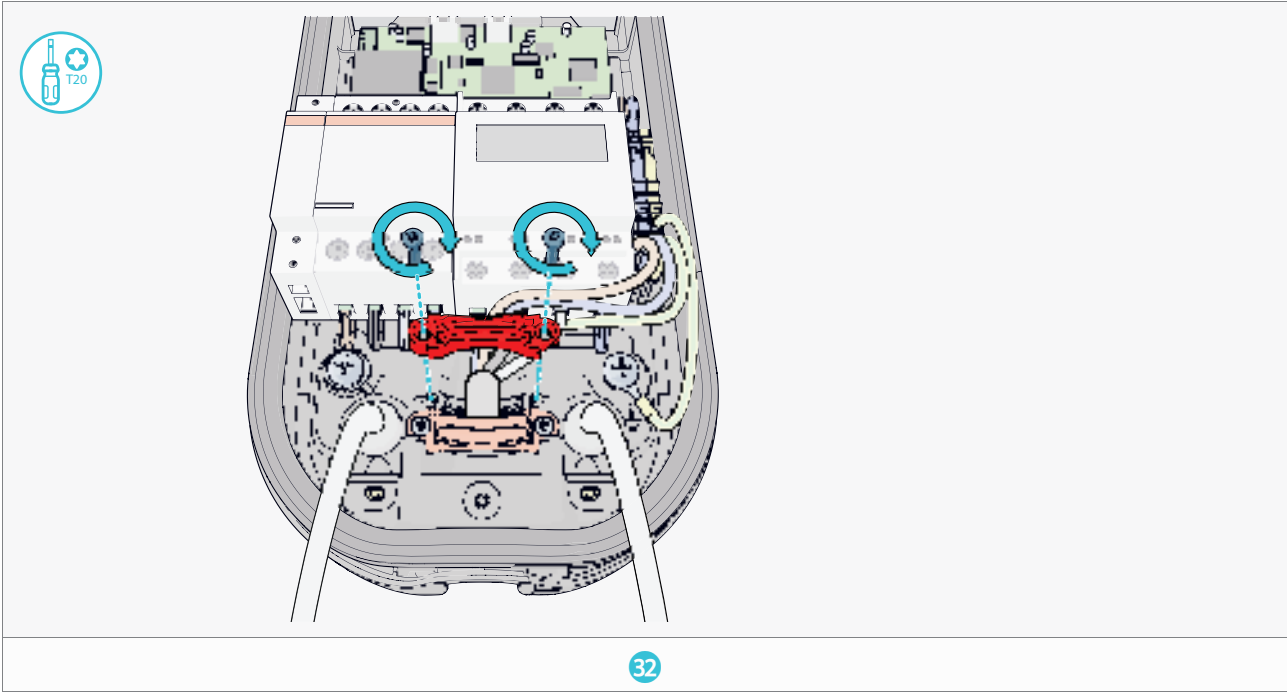

6. Secure the power cable in place with the cable clamp (see figure 32).

5.5.2. Tethered charging cable

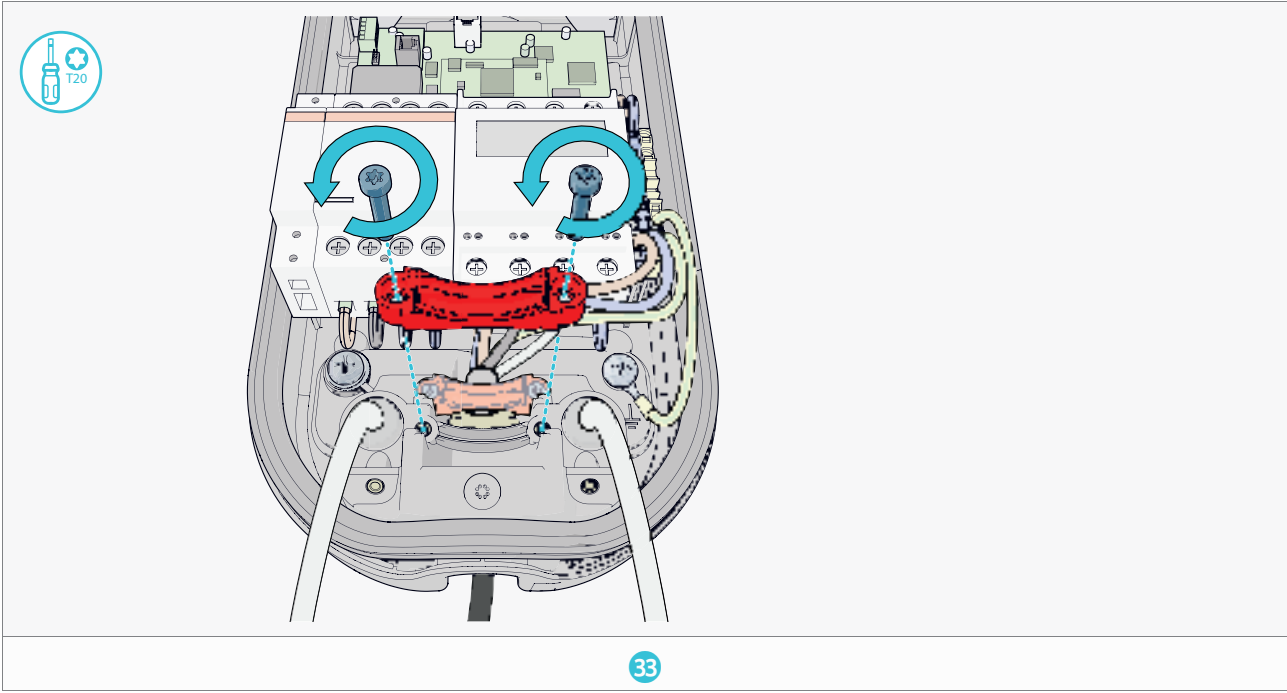

1. Remove the front cable clamp (see figure 33).

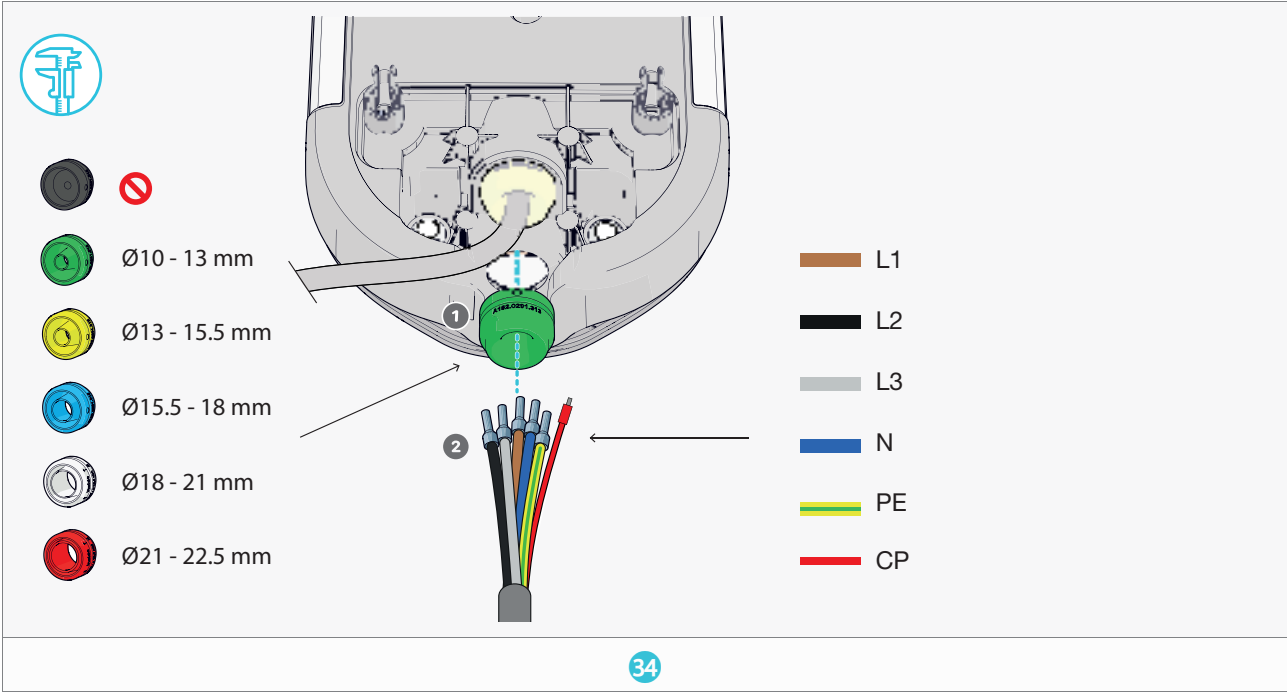

- 2. Insert the coloured grommet matching the tethered cable thickness into the front input hole (see figure 34 1).
- NOTICE** Use a caliper to measure the thickness of the tethered cable and determine the correct coloured grommet.
- 3. Feed the tethered cable through the coloured grommet. Lubricate if necessary (see figure 34 2).

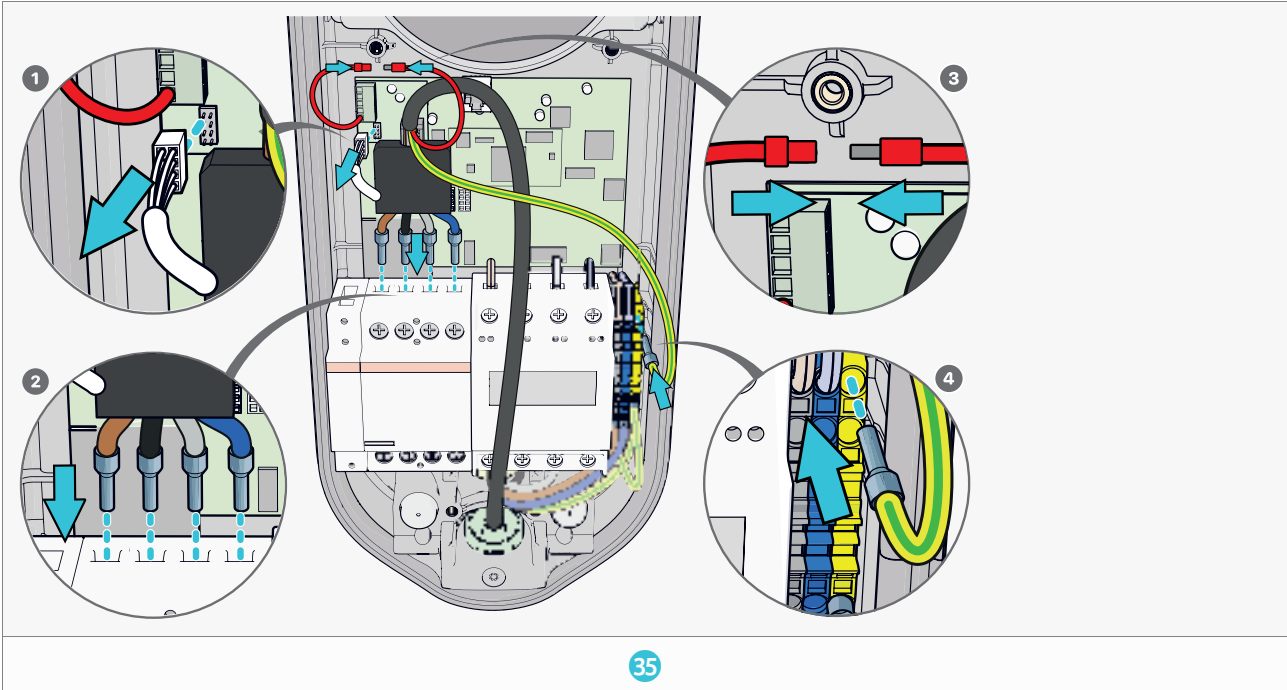

- 4. **Detach** the DC fault detection module (8-pin connector) (see figure 35 1).
- 5. Feed all tethered cable wires except for the earth wire through the DC fault detection module.
- 6. Insert the tethered cable wires into the contactors (see figure 35 2).
- 7. Connect the red car-communication wire (see figure 35 3).
- 8. Insert the earthing wire into the terminal (see figure 35 4).

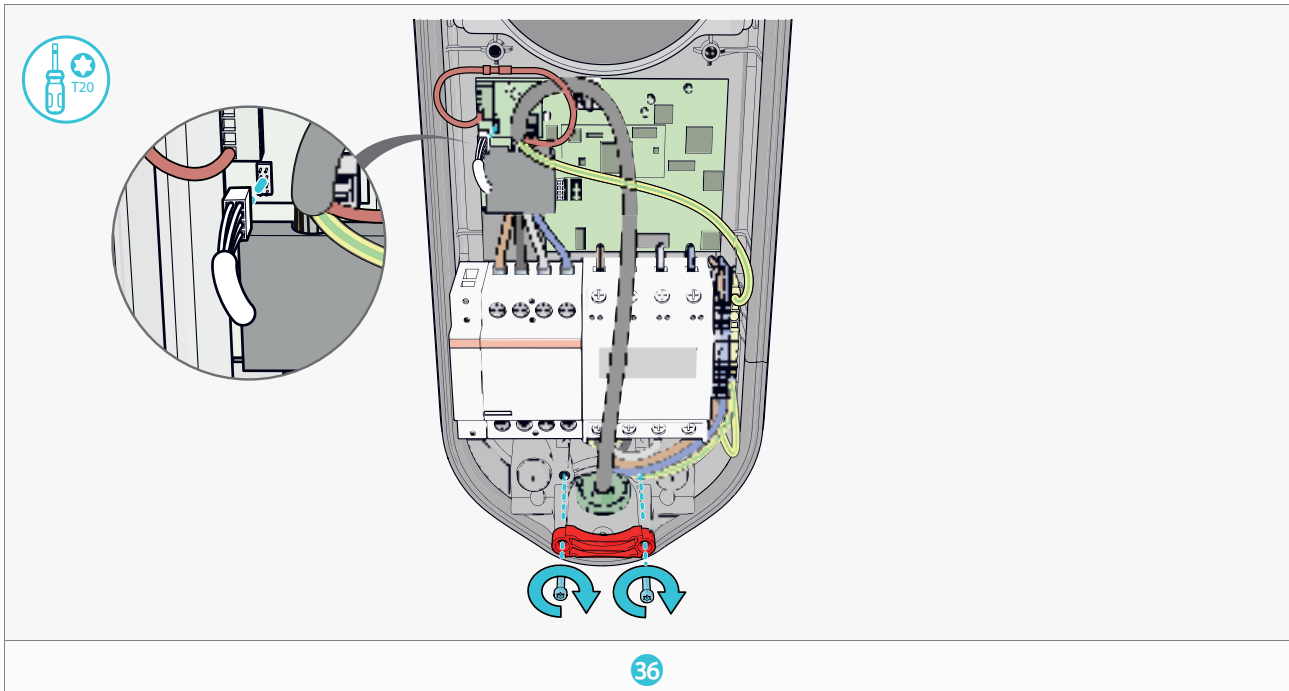

9. Connect the DC fault detection module to the PCB (see figure 36).

5.6. Wired network connection (optional)

If the GPRS signal strength is not sufficient for network communications, connect the charging point to an internet enabled router (not provided) following the steps below.

NOTICE In chapter 5.3. Preparation, you have laid out an Ethernet cable for this connection.

1. Take the Ethernet cable that leads to the router.

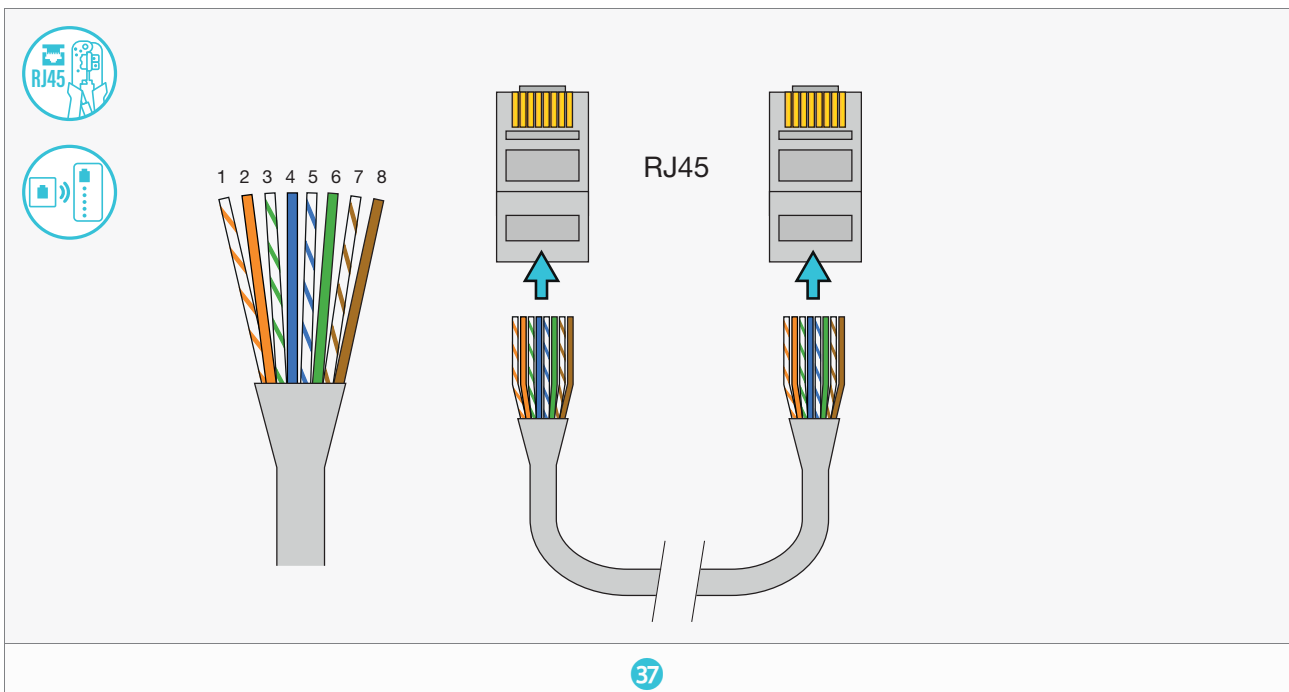

2. Strip ± 2 cm of the outer insulation from the Ethernet cable.
3. Cut the wires in a straight line and insert the wires into an RJ45 connector in the T568B-standard order, matching the image (see figure 37).
4. Secure the connector to the wires using an RJ45 crimp tool.
5. Repeat steps 2 – 4 on the other side of the cable.
6. Check if you have properly installed the connectors on both sides using an RJ45 cable tester.

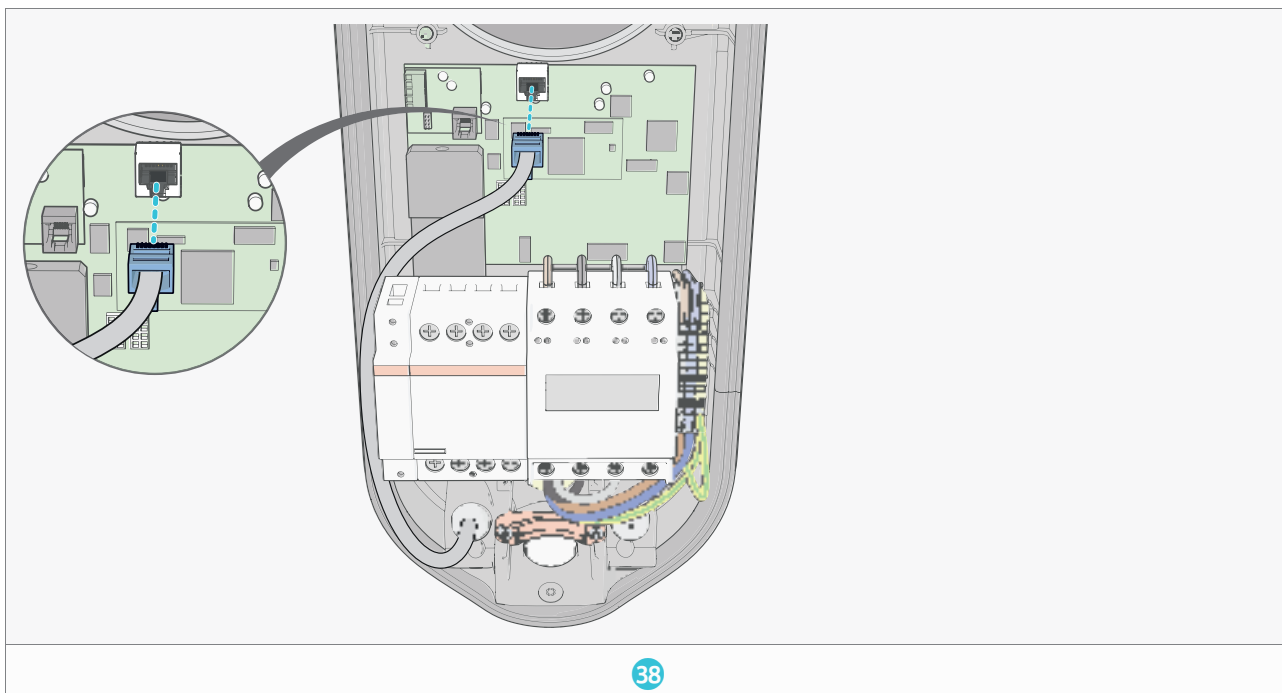

7. Plug the RJ45 connector into the Ethernet port of the charge point (see figure 38).
8. Plug the other RJ45 connector into a free Ethernet port on the router.

5.7. Installation DPM module (optional)

If the customer has purchased a Dynamic Power Management (DPM) module along with the charge point, install the DPM module in the consumer unit, following the steps below. If the DPM module is not included in the package, proceed to chapter 5.7.3. Connecting the charge point to a smart meter.

NOTICE In chapter 5.3. Preparation, you have laid out a DTP data cable for this connection.

5.7.1. Installing the DPM for Business module

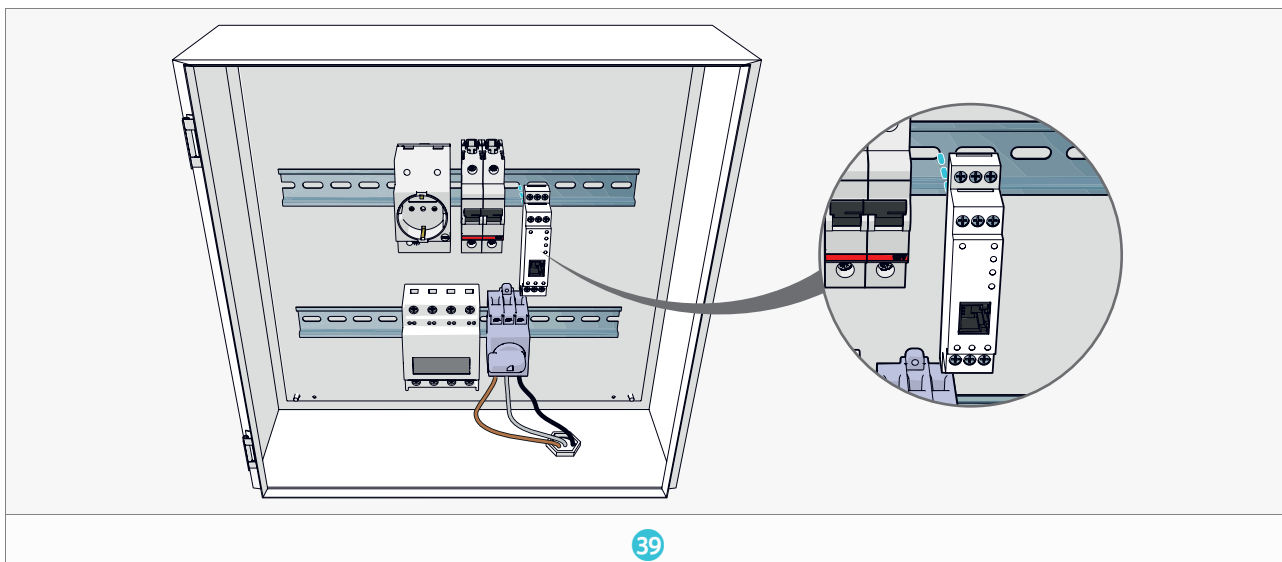

1. Mount the DPM module to a free slot on a DIN-rail in the consumer unit (see figure 39).

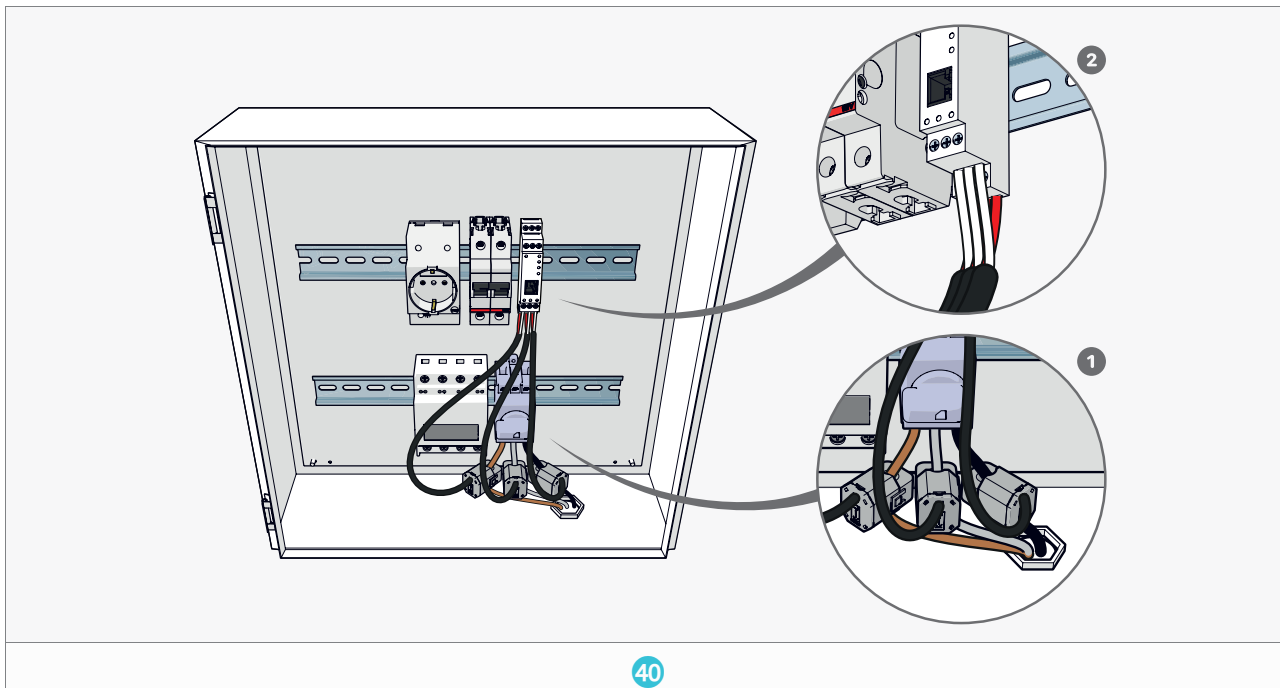

2. Mount the current transformers around the phase wires of the main grid connection (see figure 401).
3. Insert the wires of the current transformers into the matching connectors on the bottom of the DPM module (see figure 402).

NOTICE Make sure to match L1, L2 and L3 of the grid connection with L1, L2 and L3 on the DPM module.

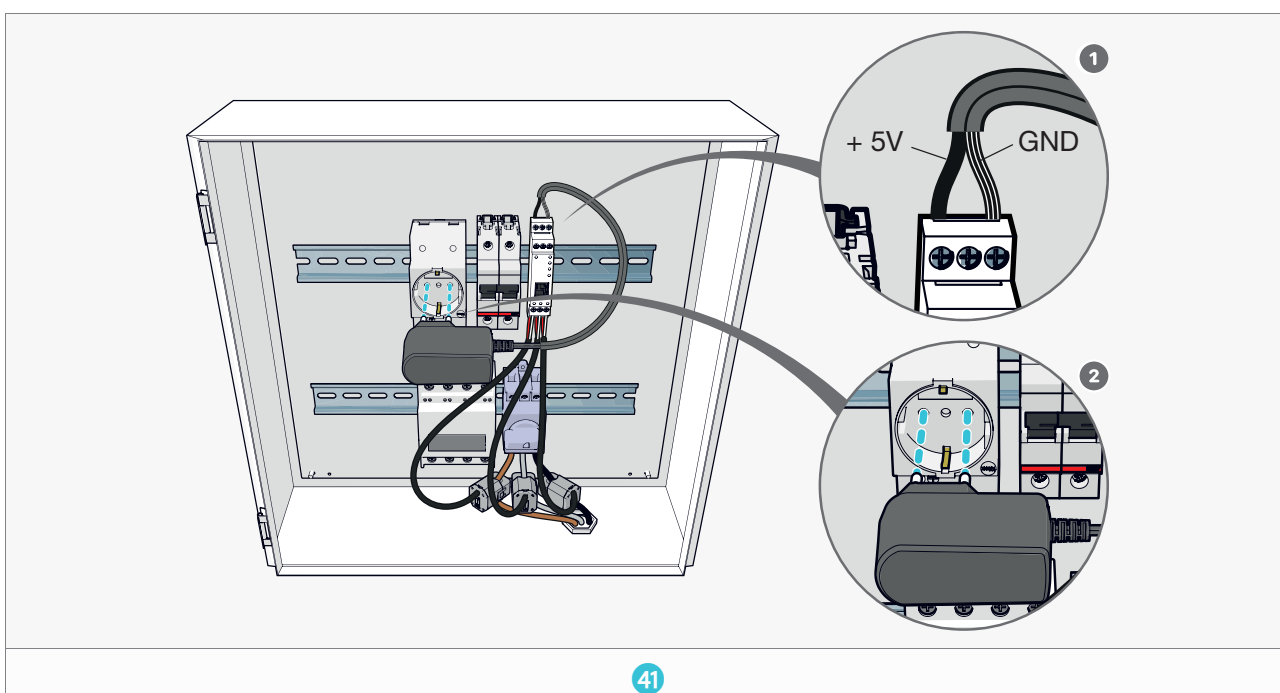

4. Insert the wires of the power supply into the connectors on the top of the DPM module (see figure 41 1).
- NOTICE** Polarity is important! The wire with the broken white stripe is the power adapter GND and should be connected to the GND pin (right) on the DPM module. The other wire is the + 5 V and should be connected to the + 5 V pin (left) on the DPM module. The middle pin is not used.
5. Plug the power supply into a working Schuko power socket (see figure 41 2) .

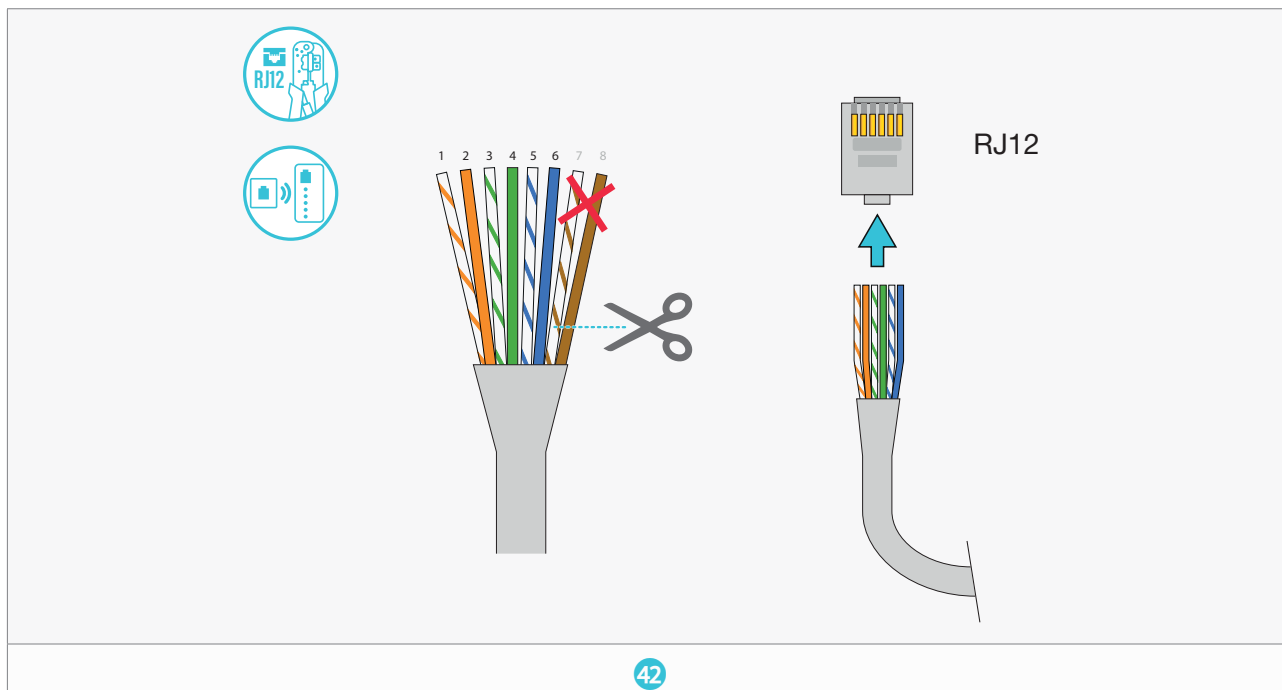

6. Strip ± 2 cm of the outer insulation from the DPM data cable.
7. Cut the wires in a straight line and insert six wires into an RJ12 connector, matching the wires (see figure 42).
8. Secure the connector to the wires using an RJ12 crimp tool.
The DPM module is now installed and prepared for connection to the charge point.

5.7.2. Connecting the charge point to the DPM module

Connect the charge point to the DPM module on the consumer unit following the steps below.

1. Ensure that phases L1, L2 and L3 of the charge point connection match phases L1, L2 and L3 on the DPM module.
2. Take the DPM data cable that leads to the consumer unit.

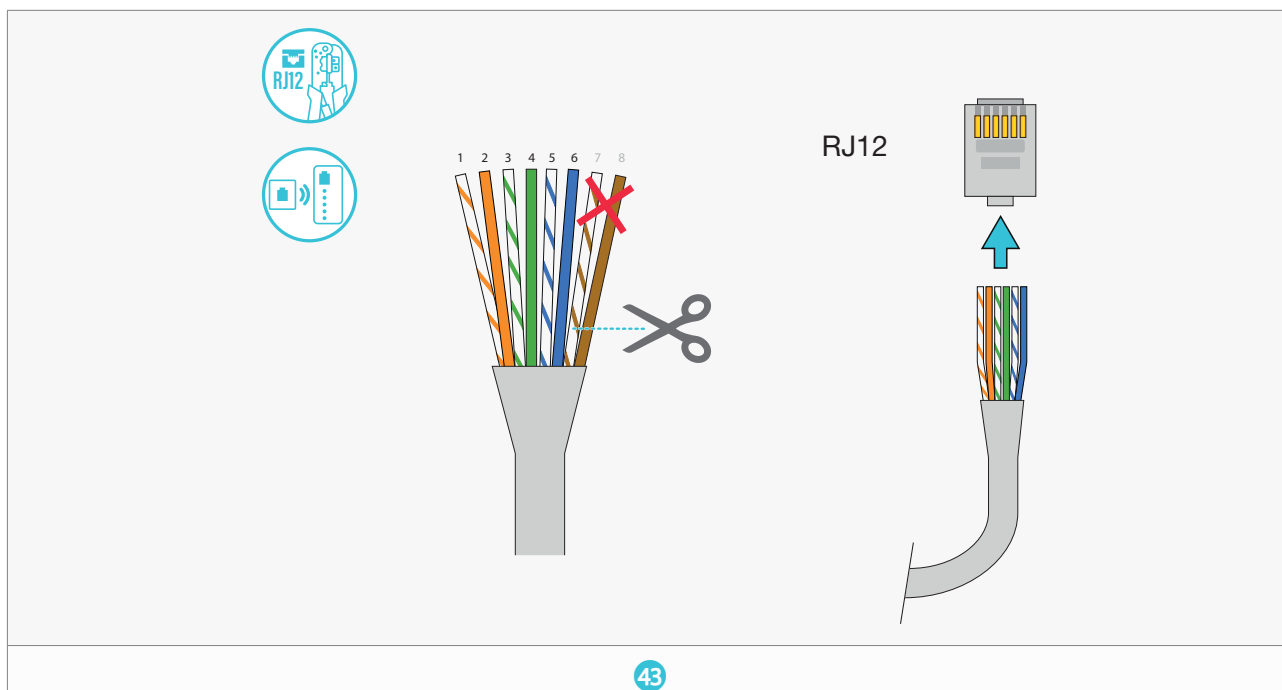

3. Strip ± 2 cm of the outer insulation from the DPM data cable.
4. Cut the wires in a straight line and insert 6 of the wires into an RJ12 connector, matching the wires (see figure 43).
5. Secure the connector to the wires using an RJ12 crimping tool.
6. Check if you have properly installed the connectors on both sides using an RJ12 network cable tester.

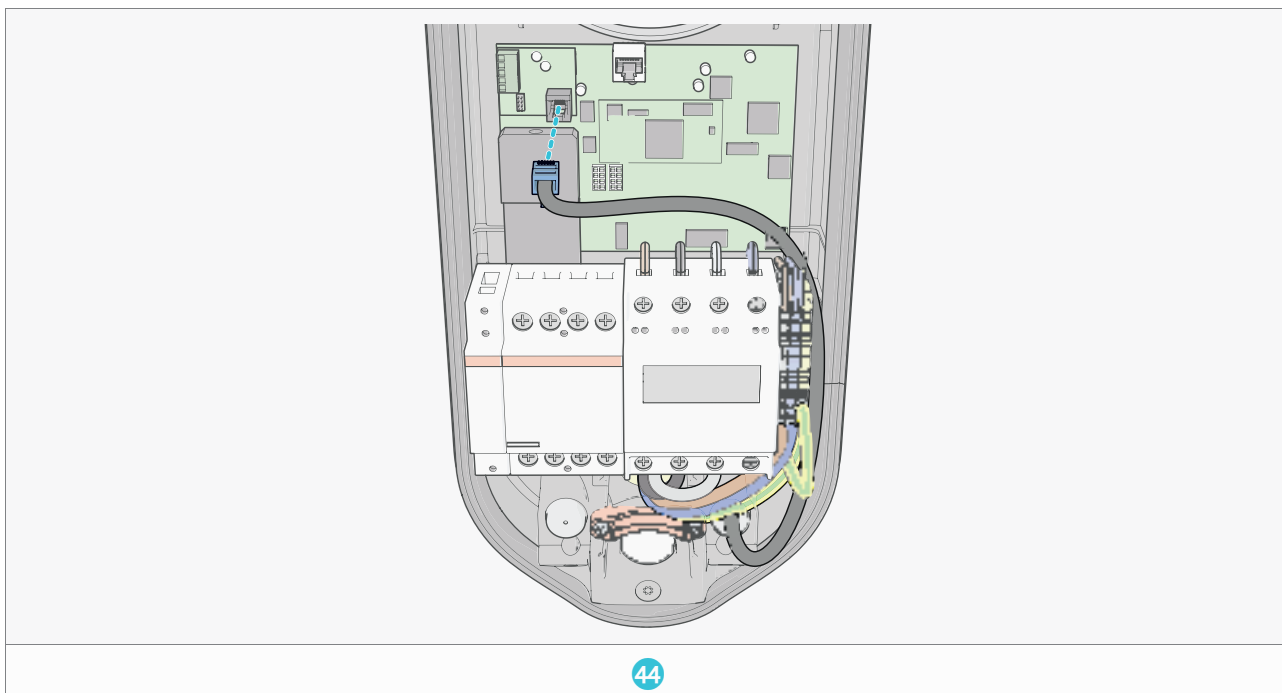

44

7. Plug the RJ12 connector into the P1 port of the charge point (see figure 44).

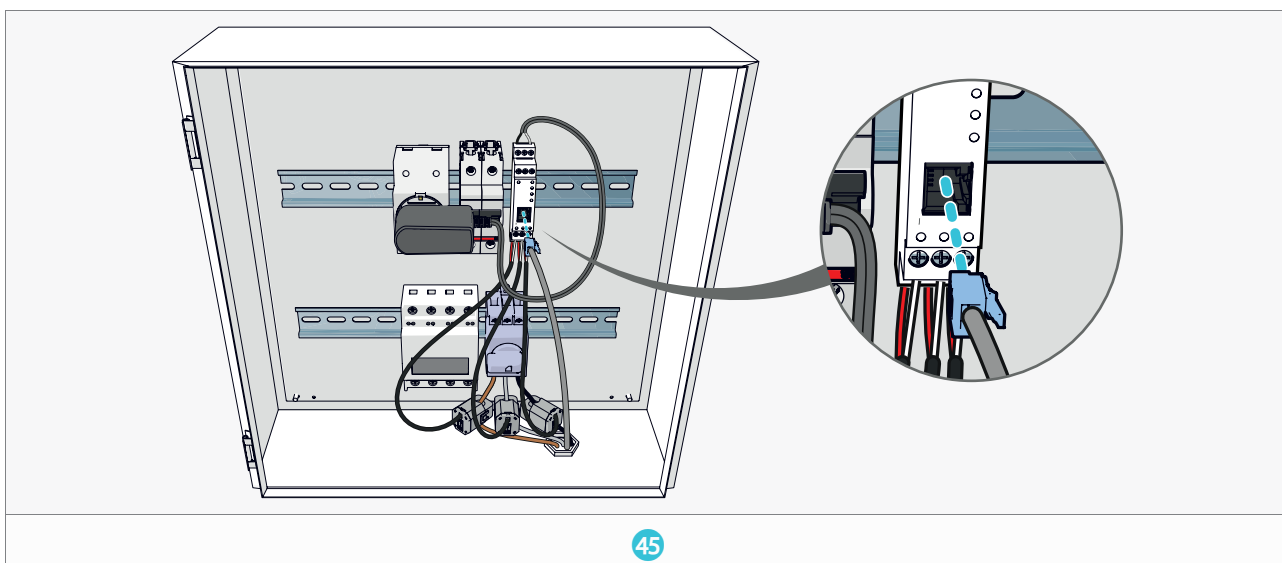

45

8. Plug the RJ12 connector into the data port on the front of the DPM module (see figure 45).

5.7.3. Connecting the charge point to a smart meter

If the smart meter on the consumer unit has SMR 4.0 or higher, you can connect the product directly to the P1 port on the smart meter, without using a DPM module. Only use this method if the DPM module is not supplied in the delivery of the charge point.

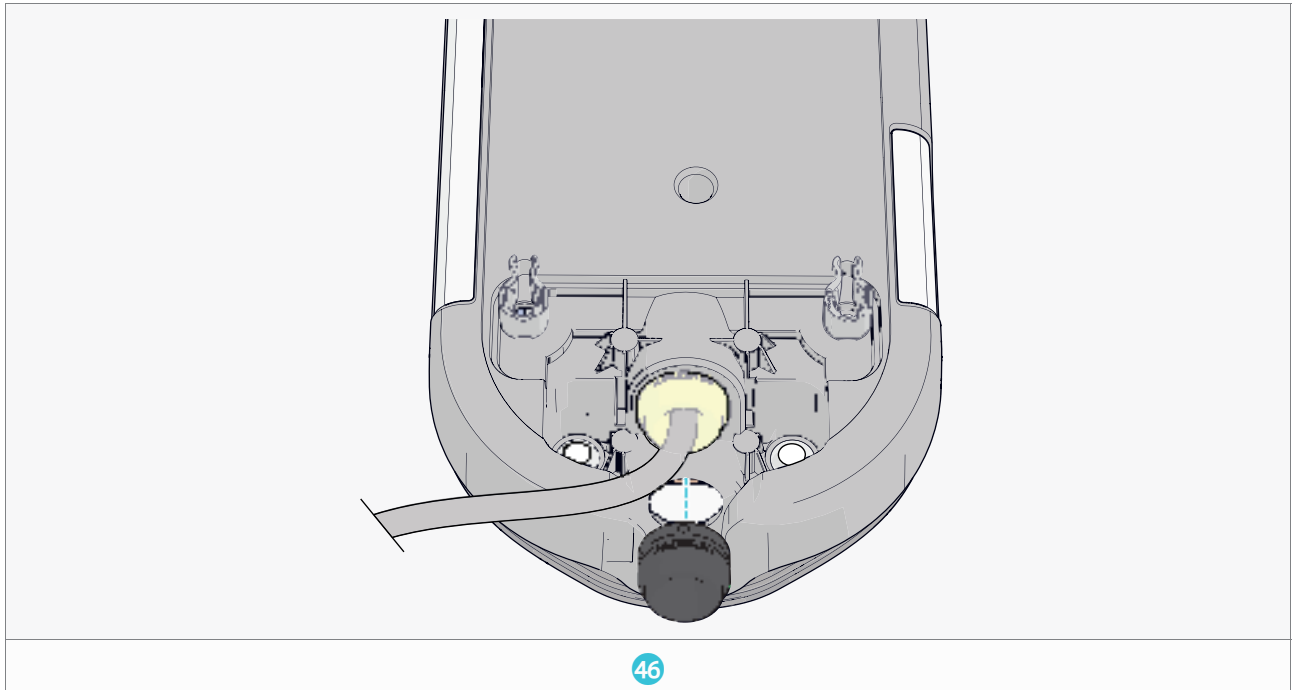

1. **NOTICE** If there is **no** tethered cable installed, insert the black grommet in the front cable inlet (see figure 46).

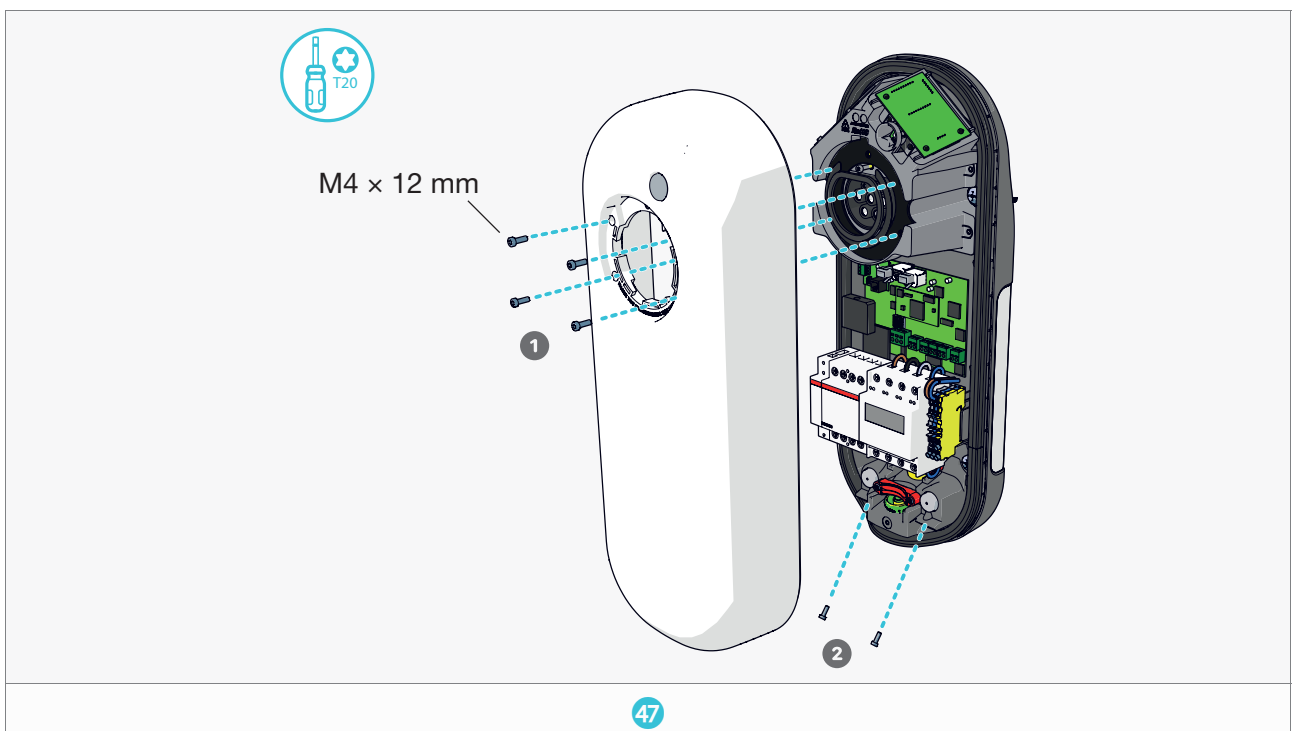

2. Ensure that the rubber seal on the edge of the casing is properly in place.
3. Place the cover on the casing (see figure 47 1).
4. Secure the cover to the casing by hand with 6 provided M4 × 12 mm Torx bolts, using a T20 screwdriver (see figure 47 2).

▲ CAUTION

Do not use an electrical screwdriver to secure the bolts, this can damage the cover or casing.

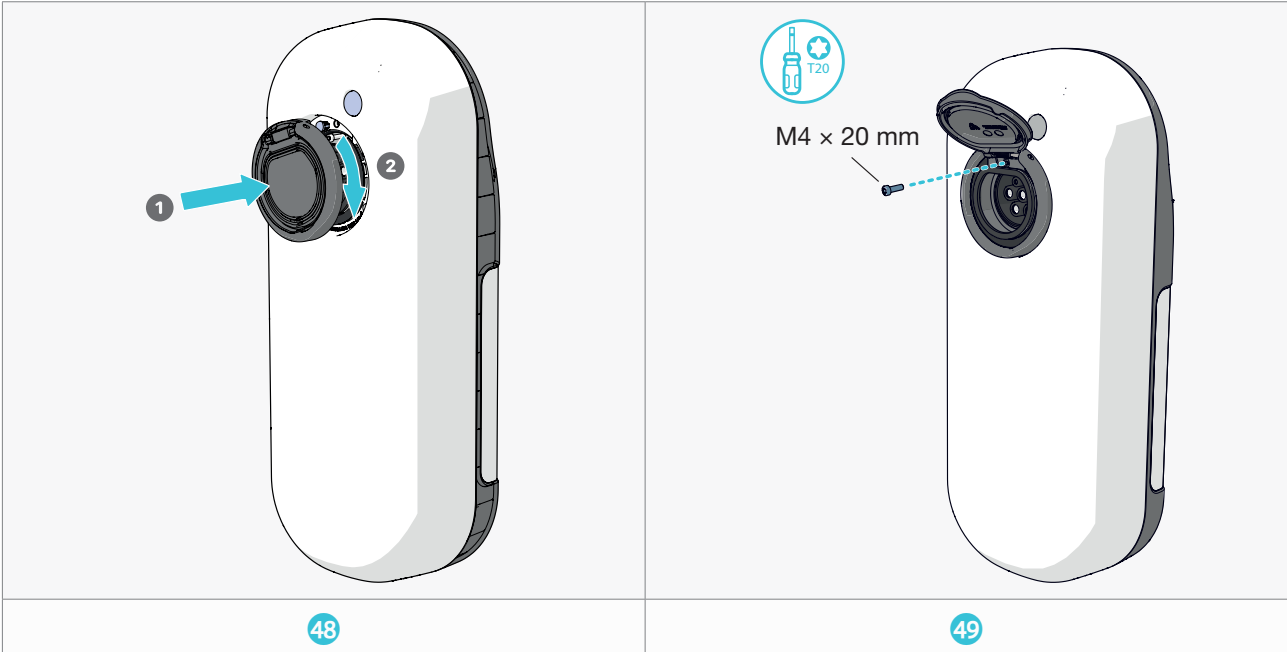

- 5. Place the grey lid slightly tilted counterclockwise into the socket hole on the cover (see figure 48).
NOTICE In case you have installed the tethered charging cable, place the dummy socket instead.
- 6. Secure the grey lid to the cover by hand with a provided M4 × 20 mm Torx bolt, using a T20 screwdriver (see figure 49).

▲ CAUTION

Do not use an electrical screwdriver to secure the bolts, this can damage the lid, cover or casing.

6. Commissioning

6.1. Activating the product

Before the charge point is ready for use, you need to activate it via <https://my.newmotion.com>. It is advised to let the customer activate the charge point on his account while the installer is installing the charge point. This will enable easy testing after the installation is finished.



NOTICE Make sure you have the serial number of the charge point at hand.

To ensure the charge point is ready for use, the owner needs to activate the charge point through our online portal at my.newmotion.com. The serial number of the charge point is needed for this process which can be found on the right hand side of the charge point. Charge cards can be activated in the same online portal.

6.2. Checks before commissioning

1. Check if all screws and connections are securely fastened;
2. Check if all phase wires are properly connected;
3. Check if the data cables are properly wired, using a network cable tester;
4. Measure the power quality on the MCB, RCD or RCBO in the consumer unit, before turning on the protection device of the charge point.

6.3. Switching on the product

1. Switch on the power to the circuit on which the charge point is installed.
The charge point starts up and the LED will blink.

NOTICE Tripping of the MCB, RCD or RCBO could be caused by an earth fault, leakage or a defect contactor. If, after resetting the MCB, RCD or RCBO, the device cannot be activated or immediately trips again; please contact NewMotion or your installer.

2. Wait until the LED stops blinking and stays off. This may take 5 - 10 minutes.
3. Check if the charging point is connected to the network via: <https://chargeportal.newmotion.com/test>



4. Enter the serial number into the search field and click "Search".
5. If "Online" appears next to the entered serial number, the charge point is connected to the network.
6. If "Online" does not appear, make sure you have performed all checks from chapter 6.2. Checks before commissioning. If you have ensured correct installation, but the problem persists, please contact NewMotion.

NOTICE If adjustment of the maximum charge point power (default setting: 16 A) is needed, please contact NewMotion.

6.4. Configuring the DPM module

If you have installed the DPM module, please use the Installer App, or contact your local NewMotion Installation desk for configuration of the Dynamic Power Management.

Write down before contacting:

1. The amperage of the main grid connection;
2. The value of the overcurrent protection device used in the charge point installation;
3. The maximum amperage of the charge point, in case the charging speed needs to be limited.

6.5. Test charge point

Test if the charge point is properly working by starting five successive charge sessions using an EV charging test adaptor connected to a heavy load, such as a hot air gun.

6.6. Regular use

6.6.1. Start charging





1. Connect your car to the charge point by plugging in the charge cable.
 - If you are using Plug&Charge the session will start automatically.
 - If you have to identify first;
2. Swipe your charge card above the LED.
 - First the LED will flash green to authenticate the card, after authentication, the session will start.
 - When the car has delayed charging configured, the LED will remain green, until charging can start from car and charge point.

NOTICE If the LED flashes red, the session is not authorised.

6.6.2. Stop charging

1. Identify.
2. Unplug.

6.6.3. Explanation of the LED colors

	Full or waiting to charge
	Plug in or identify
	Charging
	Not accepted
	Error
Flashing green or multi colors	Rebooting procedure or software update procedure for charge point.

6.7. Tethered cable

If you have purchased a charge point with tethered cable functionality. After a charge session do the following:

1. Make sure the cable is unlocked from your car.
2. Roll the cable around the back of the charge point.
3. Connect the connector into the dummy socket of the charge point.

NOTICE By placing the connector back into the dummy socket of the charge point, it's protected against water and dirt.

7. Troubleshooting

NOTICE If the issue is not solved after consulting this troubleshooter, please contact your local NewMotion Installation desk to get more help.

Problem	Possible cause	Solution
There is no light on the charge point when you turn on the power in the consumer unit	<ul style="list-style-type: none"> - The power is not connected to the charge point - Charge point broken 	<p><u>Follow steps 1-3 below:</u></p> <ol style="list-style-type: none"> 1 Check if the power cables are well inserted in the terminal block of the charge point. If the power cables are connected tightly, proceed to the next step. 2 Check if the power cable is live (230 Volt (\pm 10%)) between L1 and N) using a voltage tester. If the power cable is live, proceed to the next step. 3 Reboot the charge point by turning it off by flipping the circuit breaker in the consumer unit and turn it back on after 20 seconds. It takes around 10 minutes for the charge point to reboot. <p><u>If no result:</u></p> <ul style="list-style-type: none"> - Charge point may be broken, please contact your local NewMotion Installation desk.
There is no light on the charge point when the charge cable is plugged in	<ul style="list-style-type: none"> - The power is not connected to the charge point - Charge cable is broken 	<p><u>Follow steps 1-5 below:</u></p> <ol style="list-style-type: none"> 1 Check if the RCD and circuit breaker in the consumer unit are turned on. If turned on, proceed to the next step. 2 Check if the power cables are well inserted in the terminal block of the charge point. If the power cables are connected tightly, proceed to the next step. 3 Check if the power cable is live (230 Volt (\pm 10%)) between L1 and N) using a voltage tester. If the power cable is live, proceed to the next step. 4 Reboot the charge point by turning it off by flipping the circuit breaker in the consumer unit and turn it back on after 20 seconds. It takes around 10 minutes for the charge point to reboot. 5 If possible, try with a different charge cable that is tested on a different charge point and proved not broken. <p><u>If no result:</u></p> <ul style="list-style-type: none"> - If you are sure that the charge cable is not broken: the charge point may be broken, please contact your local NewMotion Installation desk.
LED light is flashing red	Charge point is not activated or an unauthorised charge card is being swiped	The user can activate the charge point and authorise the charge card using the portal on https://my.newmotion.com .

Problem	Possible cause	Solution
<p>LED light is constantly red with no charge cable plugged in</p>	<ul style="list-style-type: none"> - Low/high voltage warning - Grounding failure - Charge point is not leveled 	<p><u>Follow steps 1-4 below:</u></p> <p>1 Reboot the charge point by turning it off by flipping the circuit breaker in the consumer unit and turn it back on after 20 seconds. It takes around 10 minutes for the charge point to reboot. If no result, proceed to the next step.</p> <p>2 Is the charge point installed vertically? There is a tilt sensor inside the charge point that detects if the charge point is not vertical which will activate a safety mechanism preventing any charge session from starting. If the charge point is installed vertically, proceed to the next step.</p> <p>3 Measure the voltage at the grid connection between each phase and neutral. The voltage range should be within 230 Volt ± 10% (between 207 Volt and 253 Volt). If it is outside this range at the side of the customer's grid connection, inform the local grid operator about this issue. The grid operator is responsible to provide a voltage within this range. If the voltage at the grid connection is within the 10% tolerance, proceed to the next step.</p> <p>4 Measure the voltage at the charge point between each phase and neutral. The voltage range should be within 230 Volt ± 10% (between 207 Volt and 253 Volt). If it is outside this range at the side of the charge point but within this range at the grid connection, the cross section of the power cable is large enough (max. 10 mm²). If the voltage is within the 10% tolerance, proceed to the next step.</p> <p>5 Measure the earth resistance of the charge point, it should be lower than 100 Ohms. If it is higher, install a proper grounding solution. For example: add an earthing rod directly connected to the charge point.</p> <p><u>If no result:</u></p> <ul style="list-style-type: none"> - Charge point may be broken, please contact your local NewMotion Installation desk.

Problem	Possible cause	Solution
<p>LED light is constantly red with charge cable plugged in at both charge point and vehicle side</p>	<ul style="list-style-type: none"> - Problem with electric vehicle - Low/high voltage warning - Grounding failure 	<p><u>Follow steps 1-7 below:</u></p> <ol style="list-style-type: none"> 1 Reboot the charge point by turning it off by flipping the circuit breaker in the consumer unit and turn it back on after 20 seconds. It takes around 10 minutes for the charge point to reboot. Try another charge session after rebooting. If no result: proceed to the next step. 2 Check if any message appears on the dashboard of the vehicle. If no message: proceed to the next step. 3 Check if the vehicle is able to charge on a different charge point. If it is not able to charge somewhere else: tell the customer to go to the car dealer to have the vehicle tested. If the electric vehicle is able to charge on a different charge point: proceed to the next step. 4 If possible, check if a different vehicle is able to charge on the charge point. If this is possible: tell the customer to go to the car dealer. If a different vehicle is able to charge on the charge point: proceed to step 5. 5 Measure the voltage at the grid connection between each phase and neutral during a charge session. The voltage range should be within 230 Volt \pm 10% (between 207 Volt and 253 Volt). If the voltage is outside the 10% range at the side of the customer's grid connection: inform the local grid operator about this issue. The grid operator is responsible to provide a voltage within this range. If the voltage is within the 10% range during a charge session: proceed to step 6. 6 Measure the voltage at the charge point between each phase and neutral during a charge session. The voltage range should be within 230 Volt \pm 10% (between 207 Volt and 253 Volt). If it is outside this range at the side of the charge point but okay at the grid connection, see if the wiring of the power cable is thick enough (max. 10 mm²). If the voltage is within the 10% range during a charge session: proceed to the next step. 7 Measure the earth resistance of the charge point, it should be lower than 100 Ohms. If it is higher, install a proper grounding solution. For example: add an earthing rod directly connected to the charge point. <p><u>If no result after the before mentioned 7 steps:</u></p> <ul style="list-style-type: none"> - Charge point may be broken, please contact your local NewMotion Installation desk.
<p>LED light is constantly yellow for more than 10 minutes without charge cable plugged in</p>	<p>The charge point may be faulted</p>	<p><u>Follow step 1 below:</u></p> <ol style="list-style-type: none"> 1 Reboot the charge point by turning it off by flipping the circuit breaker in the consumer unit and turn it back on after 20 seconds. It takes around 10 minutes for the charge point to reboot. Try another charge session after rebooting. <p><u>If no result after the before mentioned step:</u></p> <ul style="list-style-type: none"> - Charge point may be broken, please contact your local NewMotion Installation desk.
<p>LED light is constantly green Meaning: the charge point is in charge session but charging is delayed. This is normal. This can be a problem if the car is not charged overnight.</p>	<p>If you are suspicious something may be wrong:</p> <ul style="list-style-type: none"> - The electric vehicle is delaying the charge session 	<ol style="list-style-type: none"> 1 Check if the electric vehicle has a delayed charging timer scheduled or if there is a limit on maximum battery state of charge. If so, check with the customer if this schedule and limit is indeed desired, otherwise it can be turned off. Check if the customer is able to charge on different charge points.

Problem	Possible cause	Solution
	<p>If you are suspicious something may be wrong:</p> <ul style="list-style-type: none"> - Dynamic Power Management could be activated, preventing the charge point to continue charging. 	<ol style="list-style-type: none"> 1 Disable any kind of delayed charging features of the electric vehicle. 2 Disable Dynamic Power Management using the Installer app: If the charge session is now active, proceed to the next step. 3 Check the data cable between the Dynamic Power Management module and the charge point using a network cable tester. If the data cable is tested OKAY, proceed to the next step. 4 Enable the Dynamic Power Management module again using the installer app. 5 Decrease the consumption in the household to see if the charge point will proceed charging. <p>If you are certain that the problem is with the Dynamic Power Management, please contact your local NewMotion Installation desk.</p> <p>If the vehicle is tested okay by the car dealer and the DPM module is disabled, but the light still remains green while you suspect that the charge point should be charging, please contact your local NewMotion Installation desk.</p>
LED light is flashing purple	The charge point is rebooting or doing a firmware upgrade.	Wait approximately 10 minutes for the charge point to finish rebooting. Do not interrupt the rebooting sequence by turning off the power.
LED light is blue	The charge point is in charge session and charging.	No problem, the charge point is charging. If the vehicle doesn't seem to be charging, this is not necessarily a problem. However, if this happens too often or too long (longer than one hour), tell the customer to go to the car dealer to have the vehicle tested.

8. Maintenance

8.1. Cleaning and sanitizing

It is advised to regularly clean the casing of the charge point using a simple damp cloth. Also, make sure no plants are growing on or against the charge point.

- Do not use high pressure water hose to clean the product.
- Do not use aggressive cleaning agents to clean the product.
- Do not clean the inside of the product.

8.1. Periodic maintenance

Annually check:

- if all the screws and connectors are securely tightened on the components in the consumer unit. Check the connectors of the MCB, RCD, RCBO, DPM module, etc.
- if all the screws are securely tightened on the components in the charge point. Check the connectors of the terminal blocks, power meter, contactor, etc.
- if there are no bugs or plants inside the charge point. If this is the case, use a smaller coloured grommet for the power cable or check if there is another possible way that the bugs have entered the charge point.

9. Disposal

Before disposing of the different materials, separate them into recyclables, normal waste and special waste.

Comply with local legal regulations and provisions when recycling or disposing of the product, the individual components and the packaging.

A product marked with the WEEE symbol must be sent for separate collection of electrical and electronic devices.

Appendix A - EC Declaration of Conformity

eNovater
ECOLOGICAL INNOVATION

EC DECLARATION OF CONFORMITY

BASED ON DECISION N° 766/2008/EC

This declaration of conformity is issued under the sole responsibility of the manufacturer.

Manufacturer: Ecological innovation nv.
Rijnkaai 37, 2000 Antwerpen
België

Object(s) of the declaration:

Home Advanced 2.1	with serial range 071xxxxx
Business Lite 2.1	with serial range 081xxxxx
Business Pro 2.1	with serial range 091xxxxx

These objects of the declaration are EV charge solutions, specifically wall boxes which can be identified by the serial number, printed and stickered on the outside of the charger.

The object of the declaration described above is in conformity with the relevant Community harmonisation legislation:

- Low Voltage Directive LVD (2014/35/EU and changes)
- Electromagnetic Compatibility EMC Directive (2014/30/EU and changes)
- Machinery directive (2006/42/EU and changes)
- Waste electrical and electronic equipment WEEE directive (2012/19/EU)
- Registration, Evaluation, Authorisation and Restriction of Chemicals REACH directive (1907/2006)
- Radio equipment and repealing directive (2014/53/EU)
- ROHS directive (2002/95/EC and 2011/65/EU)
- Measuring instruments directive MID (2014/32/EU)*1

*1 The used power meter, inside the object of declaration, is in conformity with this MID directive.

References to the relevant standards used and references to the specifications in relation to which conformity is declared:

- IEC 61851-1 (Electrical vehicle conductive charging system)
- IEC 61851-22 -ed 2 (AC electric vehicle charging station)
- IEC 62196
- IEC 60529 - IP54
- IEC 62262 – IK10
- EV ready 1.4G
- Following IEC 62955 for 6mA DC detection
- Following IEC 60364-7-772
- Following IEC 14443
- Following ISO 9001-2008 norm
- Following 14000-100 environmental norm

Antwerpen, Belgium 12th of February 2019 Bart Vereecke – Managing Partner

[Handwritten Signature]

Page 1 of 1

Appendix B - EC Declaration of Conformity - Cable

EN



eNovater
ECOLOGICAL INNOVATION

EC DECLARATION OF CONFORMITY

BASED ON DECISION N° 768/2008/EC

This declaration of conformity is issued under the sole responsibility of the manufacturer.

Manufacturer	Ecological Innovation nv Rijnkaai 37, 2000 Antwerpen België	
Object(s) of the declaration	Home Advanced 2.1 Cable	with serial range 071xxxxx
	Business Lite 2.1 Cable	with serial range 081xxxxx
	Business Pro 2.1 Cable	with serial range 091xxxxx

These objects of the declaration are EV charge solutions, specifically wall boxes which can be identified by the serial number, printed and stickered on the outside of the charger.

The object of the declaration described above is in conformity with the relevant Community harmonisation legislation:

- Low Voltage Directive LVD (2014/35/EU and changes)
- Electromagnetic Compatibility EMC Directive (2014/30/EU and changes)
- Machinery directive (2006/42/EU and changes)
- Waste electrical and electronic equipment WEEE directive (2012/19/EU)
- Registration, Evaluation, Authorisation and Restriction of Chemicals REACH directive (1907/2006)
- Radio equipment and repealing directive (2014/53/EU)
- ROHS directive (2002/95/EC and 2011/65/EU)
- Measuring instruments directive MID (2014/32/EU)*1

*1 The used power meter, inside the object of declaration, is in conformity with this MID directive.

References to the relevant standards used and references to the specifications in relation to which conformity is declared:

- IEC 61851-1 (Electrical vehicle conductive charging system)
- IEC 61851-22 -ed 2 (AC electric vehicle charging station)
- IEC 62196
- IEC 60529 - IP54
- IEC 62262 – IK10

- Following IEC 62955 for 6mA DC detection
- Following IEC 60364-7-772
- Following IEC 14443
- Following ISO 9001-2008 norm
- Following 14000-100 environmental norm

Antwerpen, Belgium	03rd of July 2020	Bart Vereecke – Managing Partner
---------------------------	-------------------------------------	---

Signature

CEO

Page 1 of 1



UK English - Original instructions | 071NMEN13 | 03/2021

Manufactured by: The New Motion B.V.
Rigakade 20, 1013 BC | Amsterdam, The Netherlands
+31880109500 | www.newmotion.com

