

# USER MANUAL

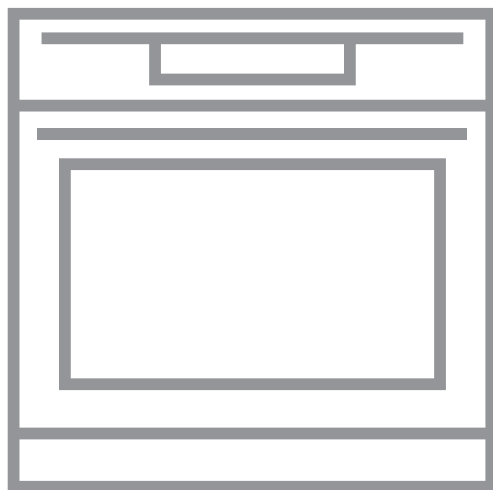

### **Important Information that may impact your Manufacturer's Warranty**

Adherence to the directions for use in this manual is extremely important for health and safety. Failure to strictly adhere to the requirements in this manual may result in personal injury, property damage and affect your ability to make a claim under the AEG manufacturer's warranty provided with your product. Products must be used, installed and operated in accordance with this manual. You may not be able to claim on the AEG manufacturer's warranty in the event that your product fault is due to failure to adhere this manual.

## CONTENTS

1. SAFETY INFORMATION.....	2
2. CONDITIONS OF USE.....	4
3. SAFETY INSTRUCTIONS.....	4
4. PRODUCT DESCRIPTION.....	7
5. CONTROL PANEL.....	8
6. BEFORE FIRST USE.....	9
7. DAILY USE.....	9
8. CLOCK FUNCTIONS.....	12
9. USING THE ACCESSORIES.....	13
10. ADDITIONAL FUNCTIONS.....	16
11. HINTS AND TIPS.....	17
12. CARE AND CLEANING.....	31
13. TROUBLESHOOTING.....	34
14. ENERGY EFFICIENCY.....	37
15. WARRANTY .....	38

## FOR PERFECT RESULTS

Thank you for choosing this AEG product. We have created it to give you impeccable performance for many years, with innovative technologies that help make life simpler features you might not find on ordinary appliances. Please spend a few minutes reading to get the very best from it.

Visit our website for:



Get usage advice, brochures, trouble shooter, service information:  
**[www.aeg.com/webselfservice](http://www.aeg.com/webselfservice)**



Register your product for better service:  
**[www.registeraeg.com](http://www.registeraeg.com)**

## CUSTOMER CARE AND SERVICE

Always use original spare parts.

When contacting our Authorised Service Centre, ensure that you have the following data available: Model, PNC, Serial Number.

The information can be found on the rating plate.

 Warning / Caution-Safety information

 General information and tips

 Environmental information

Subject to change without notice.

### 1. SAFETY INFORMATION

Before the installation and use of the appliance, carefully read the supplied instructions. The manufacturer is not responsible for any injuries or

damages that are the result of incorrect installation or usage. Always keep the instructions in a safe and accessible location for future reference.

## 1.1 Children and vulnerable people safety

- This appliance can be used by children aged from 8 years and above and persons with reduced physical, sensory or mental capabilities or lack of experience and knowledge if they have been given supervision or instruction concerning the use of the appliance in a safe way and understand the hazards involved.
- Children between 3 and 8 years of age and persons with very extensive and complex disabilities shall be kept away from the appliance unless continuously supervised.
- Children of less than 3 years of age should be kept away from the appliance unless continuously supervised.
- Do not let children play with the appliance.
- Keep all packaging away from children and dispose of it appropriately.
- Keep children and pets away from the appliance when it operates or when it cools down. Accessible parts may become hot during use.
- If the appliance has a child safety device, it should be activated.
- Children shall not carry out cleaning and user maintenance of the appliance without supervision.

## 1.2 General Safety

- Only a qualified person must install this appliance and replace the cable.
- **WARNING:** The appliance and its accessible parts become hot during use. Care should be taken to avoid touching heating elements.
- Always use oven gloves to remove or put in accessories or overware.

- Before carrying out any maintenance, disconnect the appliance from the power supply.
- **WARNING:** Ensure that the appliance is switched off before replacing the lamp to avoid the possibility of electric shock.
- Do not use the appliance before installing it in the built-in structure.
- Do not use a steam cleaner to clean the appliance.
- Do not use harsh abrasive cleaners or sharp metal scrapers to clean the glass door since they can scratch the surface, which may result in shattering of the glass.
- If the mains power supply cable is damaged, it must be replaced by the manufacturer, its Authorised Service Centre or similarly qualified persons to avoid an electrical hazard.
- Excessive spillage must be removed before the pyrolytic cleaning. Remove all parts from the oven.
- To remove the shelf supports first pull the front of the shelf support and then the rear end away from the side walls. Install the shelf supports in the opposite sequence.
- The means for disconnection must be incorporated in the fixed wiring in accordance with the wiring rules.
- Use only the food sensor (core temperature sensor) recommended for this appliance.

## 2. CONDITIONS OF USE

This appliance is intended to be used in household and similar applications such as:

- Farm houses

- By clients in serviced apartments, holiday apartments and other residential type environments.

## 3. SAFETY INSTRUCTIONS

### 3.1 Installation



**WARNING!**

Only a qualified person must install this appliance.

- Remove all the packaging.

- Do not install or use a damaged appliance.
- Follow the installation instructions supplied with the appliance.
- Always take care when moving the appliance as it is heavy. Always use safety gloves and enclosed footwear.

- Do not pull the appliance by the handle.
- Keep the minimum distance from other appliances and units.
- Install the appliance in a safe and suitable place that meets installation requirements.
- The appliance is equipped with an electric cooling system. It must be operated with the electric power supply.
- The electrical installation must have an isolation device which lets you disconnect the appliance from the mains at all poles. The isolation device must have a contact opening width of minimum 3 mm.
- Fully close the appliance door before you connect the mains plug to the mains socket.
- This appliance complies with the E.E.C. Directives.

## 3.2 Electrical connection



### WARNING!

Risk of fire and electric shock.

- All electrical connections should be made by a qualified electrician.
- The appliance must be earthed.
- Make sure that the parameters on the rating plate are compatible with the electrical ratings of the mains power supply.
- Always use a correctly installed shockproof socket.
- Do not use multi-plug adapters and extension cables.
- Make sure not to cause damage to the mains plug and to the mains cable. Should the mains cable need to be replaced, this must be carried out by our Authorised Service Centre.
- Do not let mains cables touch or come near the appliance door or the niche below the appliance, especially when it operates or the door is hot.
- The shock protection of live and insulated parts must be fastened in such a way that it cannot be removed without tools.
- Connect the mains plug to the mains socket only at the end of the installation. Make sure that there is access to the mains plug after the installation.
- If the mains socket is loose, do not connect the mains plug.
- Do not pull the mains cable to disconnect the appliance. Always pull the mains plug.
- Use only correct isolation devices: line protecting cut-outs, fuses (screw type fuses removed from the holder), earth leakage trips and contactors.

## 3.3 Use



### WARNING!

Risk of injury, burns and electric shock or explosion.

- Do not change the specification of this appliance.
  - Make sure that the ventilation openings are not blocked.
  - Do not let the appliance stay unattended during operation.
  - Deactivate the appliance after each use.
  - Be careful when you open the appliance door while the appliance is in operation. Hot air can release.
  - Do not operate the appliance with wet hands or when it has contact with water.
  - Do not apply pressure on the open door.
  - Do not use the appliance as a work surface or as a storage surface.
  - Open the appliance door carefully. The use of ingredients with alcohol can cause a mixture of alcohol and air.
  - Do not let sparks or open flames to come in contact with the appliance when you open the door.
  - Do not put flammable products or items that are wet with flammable products in, near or on the appliance.
-  **WARNING!**  
Risk of damage to the appliance.
- To prevent damage or discoloration to the enamel:
    - do not put ovenware or other objects in the appliance directly on the bottom.

- do not put aluminium foil directly on the bottom of cavity of the appliance.
- do not put water directly into the hot appliance.
- do not keep moist dishes and food in the appliance after you finish the cooking.
- be careful when you remove or install the accessories.
- Discoloration of the enamel or stainless steel has no effect on the performance of the appliance.
- Use a deep pan for moist cakes. Fruit juices cause stains that can be permanent.
- This appliance is for cooking purposes only. It must not be used for other purposes, for example room heating.
- Always cook with the oven door closed.
- If the appliance is installed behind a furniture panel (e.g. a door) make sure the door is never closed when the appliance is in operation. Heat and moisture can build up behind a closed furniture panel and cause subsequent damage to the appliance, the housing unit or the floor. Do not close the furniture panel until the appliance has cooled down completely after use.

### 3.4 Care and cleaning



#### **WARNING!**

Risk of injury, fire, or damage to the appliance.

- Before maintenance, deactivate the appliance and disconnect the mains plug from the mains socket.
- Make sure the appliance is cold. There is the risk that the glass panels can break.
- Replace immediately the door glass panels when they are damaged. Contact the Authorised Service Centre.
- Clean regularly the appliance to prevent the deterioration of the surface material.
- Clean the appliance with a moist soft cloth. Only use neutral detergents. Do not use any abrasive products,

abrasive cleaning pads, solvents or metal objects.

- If you use an oven spray, follow the safety instruction on it's packaging.
- Do not clean the catalytic enamel (if applicable) with any kind of detergent.

### 3.5 Pyrolytic cleaning



#### **WARNING!**

Risk of Injury / Fires / Chemical Emissions (Fumes) in Pyrolytic Mode.

Do not start the Pyrolysis if the Plus Steam button is pressed in.

- Before carrying out a Pyrolytic self-cleaning function or the First Use please remove from the oven cavity:
  - any excess food residues, oil or grease spills / deposits.
  - any removable objects (including shelves, side rails etc., provided with the product) particularly any non-stick pots, pans, trays, utensils etc.
- Read carefully all the instructions for Pyrolytic cleaning.
- Keep children away from the appliance while the Pyrolytic cleaning operates. The appliance becomes very hot and hot air is released from the front cooling vents.
- Pyrolytic cleaning is a high temperature operation that can release fumes from cooking residues and construction materials, as such consumers are strongly advised to:
  - provide good ventilation during and after each Pyrolytic cleaning.
  - provide good ventilation during and after the first use at maximum temperature operation.
- Unlike all humans, some birds and reptiles can be extremely sensitive to potential fumes emitted during the cleaning process of all Pyrolytic Ovens.
  - Remove any pets (especially birds) from the vicinity of the appliance location during and after the Pyrolytic cleaning and first use

maximum temperature operation to a well ventilated area.

- Small pets can also be highly sensitive to the localized temperature changes in the vicinity of all Pyrolytic Ovens when the Pyrolytic self cleaning program is in operation.
- Non-stick surfaces on pots, pans, trays, utensils etc., can be damaged by the high temperature Pyrolytic cleaning operation of all Pyrolytic Ovens and can be also a source for low level harmful fumes.
- Fumes released from all Pyrolytic Ovens / Cooking Residues as described are not harmful to humans, including children, or persons with medical conditions.

### 3.6 Internal lighting



**WARNING!**  
Risk of electric shock.

- The type of light bulb or halogen lamp used for this appliance is for

household appliances only. Do not use it for house lighting.

- Before replacing the lamp, disconnect the appliance from the power supply.
- Only use lamps with the same specifications.

### 3.7 Service

- To repair the appliance contact the Authorised Service Centre.
- Use original spare parts only.

### 3.8 Disposal



**WARNING!**  
Risk of injury or suffocation.

- Disconnect the appliance from the mains supply.
- Cut off the mains electrical cable close to the appliance and dispose of it.
- Remove the door catch to prevent children or pets from becoming trapped in the appliance.

## 4. PRODUCT DESCRIPTION

### 4.1 General overview

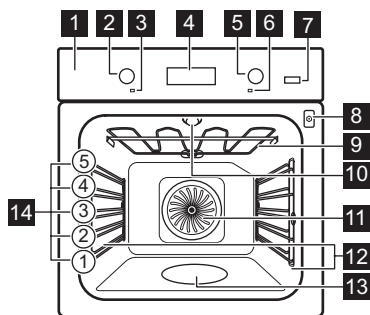

- 1 Control panel
- 2 Knob for the heating functions
- 3 Power lamp / symbol
- 4 Display
- 5 Control knob (for the temperature)
- 6 Temperature indicator / symbol
- 7 Plus Steam
- 8 Socket for the core temperature sensor
- 9 Heating element
- 10 Lamp
- 11 Fan
- 12 Shelf support, removable
- 13 Cavity embossment
- 14 Shelf positions

## 4.2 Accessories

### Wire shelf

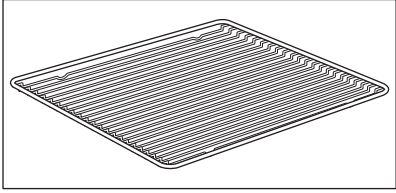

For cookware, cake tins, roasts.

### Grill- / Roasting pan

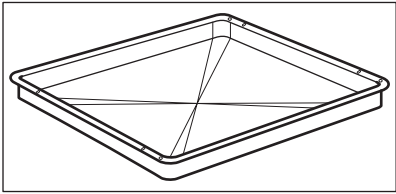

To bake and roast or as a pan to collect fat.

### Trivet

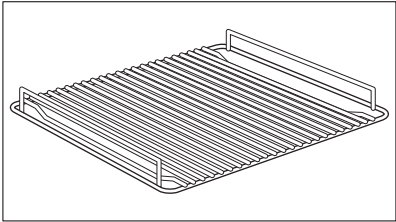

For roasting and grilling.



Use the trivet only with the Grill- / Roasting pan.

### Food Sensor

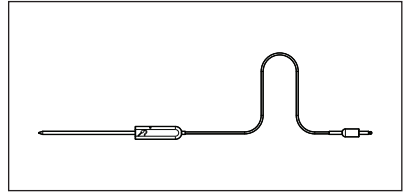

To measure the temperature inside food.

## 5. CONTROL PANEL

### 5.1 Buttons

Sensor field / Button	Function	Description
	CLOCK	To set a clock function.
	MINUS	To set the time.
	MINUTE MINDER	To set the MINUTE MINDER. Hold the button for more than 3 seconds to activate or deactivate the oven lamp.
	PLUS	To set the time.

Sensor field / Button	Function	Description
°C	TEMPERATURE	To check the oven temperature or the temperature of the core temperature sensor (if applicable). Use only while an oven function is in operation.
	PLUS STEAM	To turn on the True Fan Cooking PLUS function.

## 5.2 Display

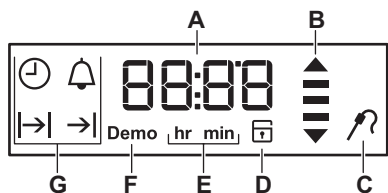

- A. Timer
- B. Heat-up and residual heat indicator
- C. Water drawer (selected models only)
- D. Core temperature sensor (selected models only)
- E. Door lock (selected models only)
- F. Hours / minutes
- G. Demo mode (selected models only)
- H. Clock functions

## 6. BEFORE FIRST USE

 **WARNING!**  
Refer to Safety chapters.

 To set the Time of day refer to "Clock functions" chapter.

Refer to "Care and cleaning" chapter.

Clean the oven and the accessories before the first use.

Put the accessories and the removable shelf supports back to their initial position.

### 6.1 Initial Cleaning

Remove all accessories and removable shelf supports from the oven.

## 7. DAILY USE





 **WARNING!**  
Refer to Safety chapters.





### 7.1 Retractable knobs

To use the appliance press the knob. The knob comes out.

### 7.2 Heating functions

Oven function	Application
0 Off position	The oven is off.
 Fast Heat Up	To decrease the heat-up time.

Oven function	Application
 <p>True Fan Cooking / True Fan Cooking PLUS</p>	<p>To bake on up to three shelf positions at the same time and to dry food.</p> <p>Set the temperature 20 - 40 °C lower than for Conventional Cooking.</p> <p>/ To add humidity during the cooking. To get the right colour and crispy crust during baking. To give more juiciness during reheating.</p>
 <p>Pizza Setting</p>	<p>To bake pizza. To make intensive browning and a crispy bottom.</p>
 <p>Conventional Cooking (Top / Bottom Heat)</p>	<p>To bake and roast food on one shelf position.</p>
 <p>Bottom Heat</p>	<p>To bake cakes with crispy bottom and to preserve food.</p>
 <p>Defrost</p>	<p>To defrost food (vegetables and fruit). The defrosting time depends on the amount and size of the frozen food.</p>

Oven function	Application
 <p>Moist Fan Baking</p>	<p>This function is designed to save energy during cooking. For the cooking instructions refer to "Hints and tips" chapter, Moist Fan Baking. The oven door should be closed during cooking so that the function is not interrupted and to ensure that the oven operates with the highest energy efficiency possible. When you use this function, the temperature in the cavity may differ from the set temperature. The residual heat is used. The heating power may be reduced. For general energy saving recommendations refer to "Energy Efficiency" chapter, Energy Saving. This function was used to comply with the energy efficiency class according to EN 60350-1. When you use this function the lamp automatically turns off after 30 seconds.</p>
 <p>Grilling</p>	<p>To grill flat food and to toast bread.</p>
 <p>Turbo Grilling</p>	<p>To roast larger meat joints or poultry with bones on one shelf position. To make gratins and to brown.</p>
 <p>Pyrolysis</p>	<p>To turn on the pyrolytic cleaning of the oven. This function burns off residual dirt in the oven.</p>

 The lamp may turn off automatically at a temperature below 60 °C during some oven functions.

## 7.3 Setting a heating function

1. Turn the knob for the heating functions to select a heating function.
2. Turn the control knob to select the temperature.

The lamp turns on when the oven operates.

3. To turn off the oven, turn the knob for the heating functions to the off position.

## 7.4 Setting the function: True Fan Cooking PLUS

This function increases humidity during cooking.



### WARNING!

Risk of burns and damage to the appliance.

Released humidity can cause burns. After the function stops, carefully open the door.

1. Fill the cavity embossment with tap water.

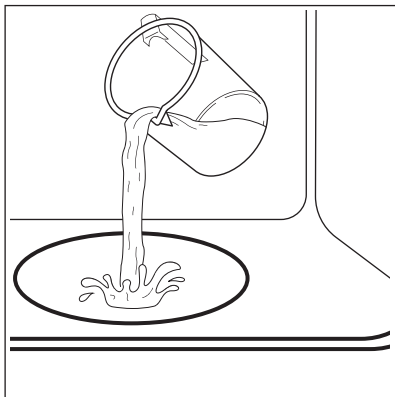

The maximum capacity of the cavity embossment is 250 ml.

Fill the cavity embossment with water only when the oven is cold.



### CAUTION!

Do not refill the cavity embossment during cooking or when the oven is hot.

2. Set the function:

3. Press: Plus Steam

It works only with the function: True Fan Cooking PLUS.

The indicator turns on.

4. Turn the control knob to set temperature.

5. Preheat the empty oven for 10 minutes to create humidity.

6. Put food in the oven.

Refer to "Hints and tips" chapter.

Do not open the oven door during cooking.

7. Turn the knob for the heating functions to the off position, press

Plus Steam

to turn off the oven.

The indicator turns off.

8. Remove water from the cavity embossment.



### WARNING!

Make sure that the oven is cold before you remove the remaining water from the cavity embossment.

## 7.5 Fast Heat Up

The fast heat up decreases the heat up time.



Do not put food in the oven when the Fast heat up operates.

1. Turn the knob for the oven functions to set the fast heat up.
2. Turn the knob for the temperature to set the temperature.

The signal sounds when the oven is at the set temperature.

3. Set an oven function.





## 7.6 Heat-up indicator

When the oven function operates, the

bars in the display appear one by one when the temperature in the oven increases, and disappear when it decreases.

## 8. CLOCK FUNCTIONS

### 8.1 Clock functions table

Clock function	Application
 TIME OF DAY	To show or change the time of day. You can change the time of day only when the oven is off.
 DURATION	To set how long the oven works. Use only when a heating function is set.
 END	To set when the oven turns off. Use only when a heating function is set.
 TIME DELAY	Combination of DURATION and END function.
 MINUTE MINDER	Use to set a countdown time. This function has no effect on the operation of the oven. You can set the MINUTE MINDER at any time, also if the oven is off.
<b>00:00</b> COUNT UP TIMER	If you do not set any other clock function the COUNT UP TIMER automatically monitor how long the oven works. It is on immediately when the oven starts to heat. The Count Up Timer cannot be used with the functions: DURATION, END, core temperature sensor.

### 8.2 Setting and changing the time



After the first connection to the mains, wait until the display shows **hr** and "**12:00**". "**12**" flashes.

1. Press **+** or **-** to set the hours.
2. Press  to confirm and set the minutes.





The display shows **min** and the set hour. "**00**" flashes.

3. Press **+** or **-** to set the current minutes.
4. Press  to confirm or the set time of day will be saved automatically after 5 seconds.



The display shows the new time.

To change the time of day press  again and again until the indicator for the time of day  flashes in the display.

### 8.3 Setting the DURATION function

1. Set a heating function.
2. Press  again and again until  starts to flash.
3. Press **+** or **-** to set the minutes and then the hours. Press  to confirm. When the set Duration time ends the signal sounds for 2 minutes.  and time setting flash in the display. The oven turns off automatically.
4. Press any button or open the oven door to stop the signal.
5. Turn the knob for the heating functions to the off position.





### 8.4 Setting the END function

1. Set a heating function.
2. Press  again and again until  starts to flash.
3. Press **+** or **-** to set the hours and then the minutes. Press  to confirm.





At the set End time the signal sounds for 2 minutes.  and time setting flash in the display. The oven turns off automatically.

4. Press any button or open the oven door to stop the signal.
5. Turn the knob for the heating functions to the off position.

## 8.5 Setting the TIME DELAY function

1. Set a heating function.
2. Press  again and again until  starts to flash.
3. Press  or  to set the minutes and then the hours for DURATION time. Press  to confirm.

The display shows flashing .

4. Press  or  to set the hours and then the minutes for END time. Press  to confirm. The display shows   and the set temperature.





Oven turns on automatically later on, works for the set DURATION time and stops at the set END time.

At the set END time the signal sounds for 2 minutes.  and time setting flash in the display. The oven turns off.



5. Press any button or open the oven door to stop the signal.
6. Turn the knob for the heating functions to the off position.

## 8.6 Setting the MINUTE MINDER

Minute minder can be both set when the oven is turned on and off.

1. Press  again and again until  and "00" flash in the display.
2. Press  or  to set the seconds and than the minutes. When the time you set is longer than 60 minutes, **hr** flash in the display.
3. Set the hours.
4. The MINUTE MINDER starts automatically after 5 seconds. After 90% of the set time the signal sounds.
5. When the set time ends the signal sounds for 2 minutes. "00:00" and  flash in the display. Press any button to stop the signal.

## 8.7 COUNT UP TIMER

To reset the Count Up Timer, press and hold  and . The timer starts to count up again.

# 9. USING THE ACCESSORIES



**WARNING!**  
Refer to Safety chapters.

## 9.1 Core temperature sensor

The core temperature sensor measures temperature inside the food. When the food is at the set temperature, the oven turns off.

There are two temperatures to be set:

- the oven temperature (minimum 120 °C),
- the food core temperature.



**CAUTION!**  
Use only the core temperature sensor supplied and the original replacement parts.

Directions for the best results:

- Ingredients should be at room temperature.
- Core temperature sensor cannot be used for liquid dishes.
- During cooking the core temperature sensor must remain in the dish and the plug in the socket.
- Use recommended food core temperature settings. Refer to "Hints and tips" chapter.

**i** Every time you put the core temperature sensor in the socket, you need to set the core temperature time again. You cannot select the duration and end time.

**i** The oven calculates the approximate cooking time, it may change.

## Food categories: meat, poultry and fish

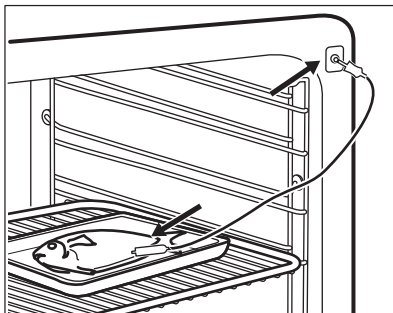
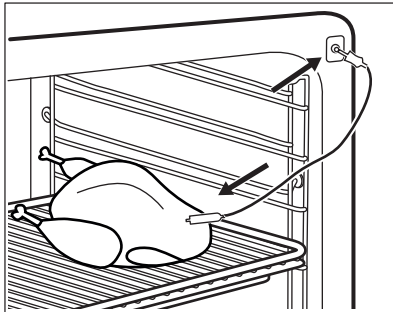

1. Set the oven function and temperature.
2. Insert the tip of the core temperature sensor into the centre of meat or fish, in the thickest part if possible. Make sure that at least 3/4 of the core temperature sensor is inside of the dish.
3. Put the plug of the core temperature sensor into the socket located in the front frame of the appliance.



The display shows the core temperature sensor symbol.

When you use the core temperature sensor for the first time, the default core temperature is 60 °C.

While  flashes, you can use the knob for the temperature to change the default core temperature. The display shows the symbol of the core temperature sensor and the default core temperature.

4. Press  to save the new core temperature, or wait 10 seconds for the setting to be saved automatically. The new default core temperature is displayed during the next use of the core temperature sensor. When the food is at the set core temperature, the default core temperature and  flashes. An acoustic signal sounds for 2 minutes.
5. Press any button or open the oven door to stop the acoustic signal.
6. Remove the core temperature sensor plug from the socket and remove the dish from the appliance.



### WARNING!

There is a risk of burns as the core temperature sensor becomes hot. Be careful when you unplug it and remove it from the dish.

## Food category: casserole

1. Set the oven function and temperature.
2. Place half of the ingredients in a baking dish.
3. Insert the tip of the core temperature sensor exactly in the centre of the casserole. The core temperature sensor should be stabilized in one place during baking. Use a solid ingredient to achieve that. Use the rim of the baking dish to support the silicone handle of the core temperature sensor. The tip of the core temperature sensor should not touch the bottom of a baking dish.

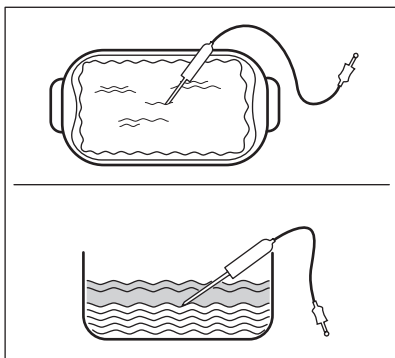

4. Cover the core temperature sensor with the remaining ingredients.
5. Put the plug of the core temperature sensor into the socket located in the front frame of the appliance.

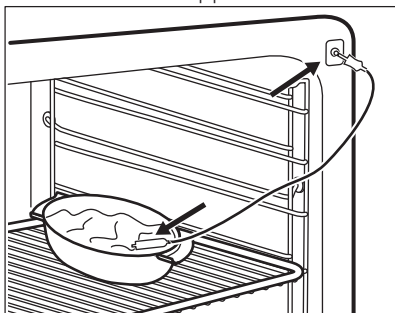

The display shows the core temperature sensor symbol.

6. Press  to save the new core temperature, or wait 10 seconds for the setting to be saved automatically.

The new default core temperature is displayed during the next use of the core temperature sensor.

When the food is at the set core temperature, the default core temperature and  flashes. An acoustic signal sounds for 2 minutes.

7. Press any button or open the oven door to stop the acoustic signal.
8. Remove the core temperature sensor plug from the socket and remove the dish from the appliance.



### WARNING!

There is a risk of burns as the core temperature sensor becomes hot. Be careful when you unplug it and remove it from the dish.

## Changing the temperature during the cooking

You can change the temperature at any time during the cooking:

1. Press  $^{\circ}\text{C}$ :
  - one time - the display shows the set core temperature which changes every 10 seconds to the current core temperature.
  - two times - the display shows the current oven temperature which changes every 10 seconds to the set oven temperature.
  - three times - the display shows the set oven temperature.
2. Use the knob for the temperature to change the temperature.

## 9.2 Inserting the accessories

Wire shelf:

Push the shelf between the guide bars of the shelf support .

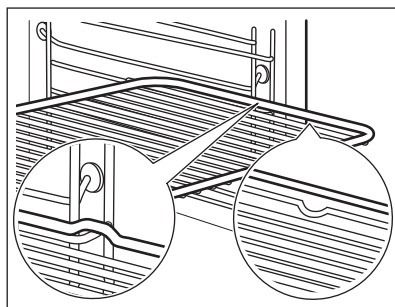

Deep pan:

Push the deep pan between the guide bars of the shelf support.

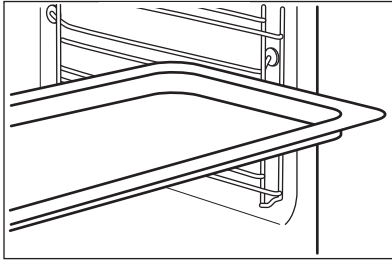

Wire shelf and deep pan together:  
Push the deep pan between the guide bars of the shelf support and the wire shelf on the guide bars above.

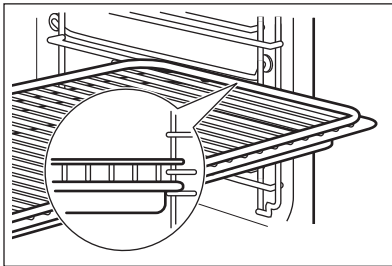

**i** Small indentation at the top increase safety. The indentations are also anti-tip devices. The high rim around the shelf prevents cookware from slipping of the shelf.



### 9.3 Trivet and Grill- / Roasting pan

**!** **WARNING!**  
Be careful when you remove the accessories from a hot oven. There is a risk of burns.

## 10. ADDITIONAL FUNCTIONS

### 10.1 Using the Child Lock

When the Child Lock is on the oven cannot be turned on accidentally.

1. Ensure the knob for the oven functions is in the off position.
2. Press and hold  and  at the same time for 2 seconds.

You can use the trivet to roast larger pieces of meat or poultry on one shelf position.

1. Put the trivet into the deep pan so that the supports of the wire shelf point up.

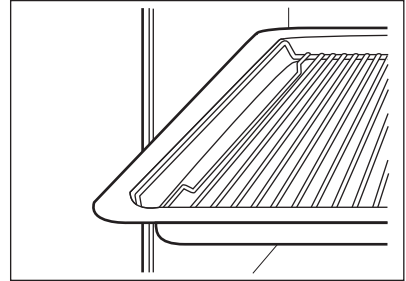

2. Put the deep pan into the oven on the necessary shelf position.  
You can use the trivet to grill flat dishes in large quantities and to toast.

1. Put the trivet into the deep pan so that the supports of the wire shelf point down.

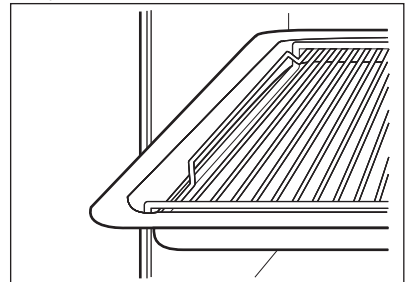

2. Put the deep pan into the oven on the necessary shelf position.

The signal sounds.  and  appear on the display. The door is locked.



**i** The symbol  appear on the display also when Pyrolysis function operates.

To turn off the Child Lock, repeat step 2.

## 10.2 Using the Function Lock

You can turn on the Function Lock function only when the oven operates.

When the Function lock is on the temperature and time settings of a running oven function cannot be changed accidentally.



1. Select an oven function and set it according your preferences.
2. Press and hold  and  at the same time for 2 seconds.

The signal sounds. Loc appears on the display for 5 seconds.

 Loc appears on the display when you turn the knob for the temperature or press any button when the Function lock is on.

When you turn the knob for the oven functions, the oven stops.

When you turn off the oven while the Function Lock is on, the Function Lock switches automatically to the Child Lock. Refer to "Using the Child Lock".

 If the Pyrolysis function operates, the door is locked and  appears on the display.

To turn off the Function Lock, repeat step 2.



## 10.3 Residual heat indicator

When you turn off the oven, the display shows the residual heat indicator  if

the temperature in the oven is more than 40 °C. Turn the knob for the temperature left or right to check the oven temperature.

## 10.4 Automatic Switch-Off

For safety reasons the oven turns off automatically after some time, if a heating function works and you do not change any settings.

 (°C)	 (h)
30 - 115	12.5
120 - 195	8.5
200 - 245	5.5
250 - maximum	3
Pyrolysis	4.5

The Automatic Switch-off does not work with the functions: Light, Food Sensor, Duration, End Time.

## 10.5 Cooling fan

When the oven operates, the cooling fan turns on automatically to keep the surfaces of the oven cool. If you turn off the oven, the cooling fan can continue to operate until the oven cools down.

# 11. HINTS AND TIPS



**WARNING!**  
Refer to Safety chapters.



The temperature and baking times in the tables are guidelines only. They depend on the recipes and the quality and quantity of the ingredients used.

## 11.1 Cooking recommendations

Your oven may bake or roast differently to the oven you had before. The below tables provide you with the standard settings for temperature, cooking time and shelf position.

If you cannot find the settings for a special recipe, look for the similar one.

## 11.2 Inner side of the door

**On the inner side of the door you can find:**

- the numbers of the shelf positions.
- information about the oven functions, recommended shelf positions and temperatures for dishes.

## 11.3 True Fan Cooking PLUS

Cakes / pastries / breads  
Use the second shelf position.

Use 150 ml of water.

Use the baking tray.

Preheat the empty oven for 5 minutes.

Food	Temperature (°C)	Time (min)
Cookies / Scones / Croissants	150 - 180	10 - 20
Focaccia	200 - 210	10 - 20
Pizza	230	10 - 20
Bread rolls	200	20 - 25
Bread	180	35 - 40
Plum cake / Apple pie / Cinnamon rolls, baked in a cake mould	160 - 180	30 - 60

Frozen ready meals  
Use the second shelf position.

Use 200 ml of water.

Preheat the empty oven for 10 minutes.

Food	Temperature (°C)	Time (min)
Pizza	200 - 210	10 - 20
Croissants	170 - 180	15 - 25
Lasagne	180 - 200	35 - 50

Food regeneration  
Use the second shelf position.

Use 100 ml of water.

Set the temperature to 110 °C.

Food	Time (min)
Bread rolls	10 - 20
Bread	15 - 25
Focaccia	15 - 25
Meat	15 - 25
Pasta	15 - 25
Pizza	15 - 25
Rice	15 - 25
Vegetables	15 - 25

Roasting  
Use the second shelf position.

Use 200 ml of water.

Use the glass baking dish.

Food	Temperature (°C)	Time (min)
Roast beef	200	50 - 60
Chicken	210	60 - 80
Roast pork	180	65 - 80

## 11.4 Baking

Use the lower temperature the first time.

You can extend baking times by 10 – 15 minutes if you bake cakes on more than one shelf position.

Cakes and pastries at different heights do not always brown equally. There is no need to change the temperature setting if an unequal browning occurs. The differences equalize during baking.

Trays in the oven can twist during baking. When the trays become cold again, the distortions disappear.

## 11.5 Tips on baking

Baking results	Possible cause	Remedy
The bottom of the cake is not baked sufficiently.	The shelf position is incorrect.	Put the cake on a lower shelf.
The cake sinks and becomes soggy or streaky.	The oven temperature is too high.	Next time set slightly lower oven temperature.
	The baking time is too short.	Next time set a longer baking time and lower oven temperature.
The cake is too dry.	The oven temperature is too low.	Next time set higher oven temperature.
	The baking time is too long.	Next time set shorter baking time.
The cake bakes unevenly.	The oven temperature is too high and the baking time is too short.	Set lower oven temperature and longer baking time.
	The cake batter is not evenly distributed.	Next time spread the cake batter evenly on the baking tray.
The cake is not ready in the baking time specified in a recipe.	The oven temperature is too low.	Next time set a slightly higher oven temperature.

## 11.6 Baking on one shelf level

### Baking in tins

Use the function: True Fan Cooking.

Food	Temperature (°C)	Time (min)	Shelf position
Flan base - short pastry, preheat the empty oven	170 - 180	10 - 25	2
Flan base - sponge cake mixture	150 - 170	20 - 25	2
Ring cake / Brioche	150 - 160	50 - 70	1
Madeira cake / Fruit cakes	140 - 160	70 - 90	1

### Baking in tins

Use the first shelf position.

Use the function: Conventional Cooking / Top / Bottom Heat.

Food	Temperature (°C)	Time (min)
Cheesecake	170 - 190	60 - 90

### Cakes, pastries, breads

Use the third shelf position.

Use the function: True Fan Cooking.

Use the baking tray.

Food	Temperature (°C)	Time (min)
Cake with crumble topping	150 - 160	20 - 40
Fruit flans (made of yeast dough / sponge cake mixture), use the deep pan	150	35 - 55

Food	Temperature (°C)	Time (min)
Fruit flans made of short pastry	160 - 170	40 - 80

### Cakes, pastries, breads

Preheat the empty oven.

Use the function: Conventional Cooking / Top / Bottom Heat.

Use the baking tray.

Food	Temperature (°C)	Time (min)	Shelf position
Swiss roll	180 - 200	10 - 20	3
Rye bread: 1. Start with: 2. Continue with:	1. 230 2. 160 - 180	1. 20 2. 30 - 60	1
Buttered almond cake / Sugar cakes	190 - 210	20 - 30	3
Cream puffs / Eclairs	190 - 210	20 - 35	3
Plaited bread / Bread crown	170 - 190	30 - 40	3
Fruit flans (made of yeast dough / sponge cake mixture), use the deep pan	170	35 - 55	3
Yeast cakes with delicate toppings (e.g. quark, cream, custard)	160 - 180	40 - 80	3
Christstollen	160 - 180	50 - 70	2

### Biscuits

Use the third shelf position.

Use the function: True Fan Cooking.

Food	Temperature (°C)	Time (min)
Short pastry biscuits	150 - 160	10 - 20
Rolls, preheat the empty oven	160	10 - 25
Biscuits made of sponge cake mixture	150 - 160	15 - 20
Puff pastries, preheat the empty oven	170 - 180	20 - 30
Biscuits made of yeast dough	150 - 160	20 - 40
Macaroons	100 - 120	30 - 50

Food	Temperature (°C)	Time (min)
Pastries made of egg white / Meringues	80 - 100	120 - 150

### Biscuits

Preheat the empty oven.

Use the third shelf position.

Use the function: Conventional Cooking / Top / Bottom Heat.

Food	Temperature (°C)	Time (min)
Rolls	190 - 210	10 - 25

### 11.7 Bakes and gratins



Use the first shelf position.

Food	Function	Temperature (°C)	Time (min)
Baguettes topped with melted cheese	True Fan Cooking	160 - 170	15 - 30
Vegetables au gratin, preheat the empty oven	Turbo Grilling	160 - 170	15 - 30
Lasagne	Conventional Cooking / Top / Bottom Heat	180 - 200	25 - 40
Fish bakes	Conventional Cooking / Top / Bottom Heat	180 - 200	30 - 60
Stuffed vegetables	True Fan Cooking	160 - 170	30 - 60
Sweet bakes	Conventional Cooking / Top / Bottom Heat	180 - 200	40 - 60
Pasta bake	Conventional Cooking / Top / Bottom Heat	180 - 200	45 - 60

### 11.8 Moist Fan Baking

For the best results follow suggestions listed in the table below.

Use the third shelf position.

	 (°C)	 (min)
Pasta gratin	200 - 220	45 - 55
Potato gratin	180 - 200	70 - 85
Moussaka	170 - 190	70 - 95
Lasagne	180 - 200	75 - 90
Cannelloni	180 - 200	70 - 85
Bread pudding	190 - 200	55 - 70
Rice pudding	170 - 190	45 - 60
Apple cake, made of sponge cake mixture (round cake tin)	160 - 170	70 - 80
White bread	190 - 200	55 - 70

## 11.9 Multilevel Baking

Use the baking trays.

Use the function: True Fan Cooking.

Cakes, pastries

Food	Temperature (°C)	Time (min)	Shelf position	
			2 positions	3 positions
Cream puffs / Eclairs	160 - 180 , preheat the empty oven	25 - 45	1 / 4	-
Dry streusel cake	150 - 160	30 - 45	1 / 4	-

Biscuits, small cakes, pastries, rolls

Food	Temperature (°C)	Time (min)	Shelf position	
			2 positions	3 positions
Rolls	180	20 - 30	1 / 4	-
Short pastry bis- cuits	150 - 160	20 - 40	1 / 4	1 / 3 / 5
Biscuits made of sponge cake mixture	160 - 170	25 - 40	1 / 4	-

Food	Temperature (°C)	Time (min)	Shelf position	
			2 positions	3 positions
Puff pastries	170 - 180 preheat the empty oven	30 - 50	1 / 4	-
Biscuits made of yeast dough	160 - 170	30 - 60	1 / 4	-
Macaroons	100 - 120	40 - 80	1 / 4	-
Biscuits made of egg white / Meringues	80 - 100	130 - 170	1 / 4	-

### 11.10 Crispy baking with: Pizza Setting

Use the first shelf position.

Food	Temperature (°C)	Time (min)
Tarts	180 - 200	40 - 55
Spinach flan	160 - 180	45 - 60
Quiche lorraine / Swiss flan	170 - 190	45 - 55
Cheesecake	140 - 160	60 - 90
Apple pie, covered	150 - 170	50 - 60
Vegetable pie	160 - 180	50 - 60

Preheat the empty oven before cooking.

Use the second shelf position.

Food	Temperature (°C)	Time (min)
Pizza, thin crust, use the deep pan	200 - 230	15 - 20
Pizza, thick crust	180 - 200	20 - 30

Food	Temperature (°C)	Time (min)
Unleavened bread	230 - 250	10 - 20
Puff pastry flan	160 - 180	45 - 55
Flammkuchen	230 - 250	12 - 20
Pierogi	180 - 200	15 - 25

### 11.11 Tips on Roasting

Use heat-resistant ovenware.

Roast lean meat covered.

Roast large meat joints directly in the tray or on the wire shelf placed above the tray.

Put some water in the tray to prevent dripping fat from burning.

Turn the roast after 1/2 - 2/3 of the cooking time.

Roast meat and fish in large pieces (1 kg or more).

Baste meat joints with their own juice several times during roasting.

### 11.12 Roasting tables

Use the first shelf position.

## Beef

Food	Quantity	Function	Temperature (°C)	Time (min)
Pot roast	1 - 1.5 kg	Conventional Cooking / Top / Bottom Heat	230	120 - 150
Roast beef or fillet, rare, preheat the empty oven	per cm of thickness	Turbo Grilling	190 - 200	5 - 6
Roast beef or fillet, medium, preheat the empty oven	per cm of thickness	Turbo Grilling	180 - 190	6 - 8
Roast beef or fillet, well done, preheat the empty oven	per cm of thickness	Turbo Grilling	170 - 180	8 - 10

## Pork

Use the function: Turbo Grilling.

Food	Quantity (kg)	Temperature (°C)	Time (min)
Shoulder / Neck / Ham joint	1 - 1.5	160 - 180	90 - 120
Chops / Spare rib	1 - 1.5	170 - 180	60 - 90
Meatloaf	0.75 - 1	160 - 170	50 - 60
Pork knuckle, precooked	0.75 - 1	150 - 170	90 - 120

## Veal

Use the function: Turbo Grilling.

Food	Quantity (kg)	Temperature (°C)	Time (min)
Roast veal	1	160 - 180	90 - 120
Veal knuckle	1.5 - 2	160 - 180	120 - 150

## Lamb

Use the function: Turbo Grilling.

Food	Quantity (kg)	Temperature (°C)	Time (min)
Lamb leg / Roast lamb	1 - 1.5	150 - 170	100 - 120
Lamb saddle	1 - 1.5	160 - 180	40 - 60

## Game

Use the function: Conventional Cooking / Top / Bottom Heat.

Food	Quantity (kg)	Temperature (°C)	Time (min)
Saddle / Hare leg, preheat the empty oven	up to 1	230	30 - 40
Venison saddle	1.5 - 2	210 - 220	35 - 40
Haunch of venison	1.5 - 2	180 - 200	60 - 90

## Poultry

Use the function: Turbo Grilling.

Food	Quantity (kg)	Temperature (°C)	Time (min)
Poultry, portions	0.2 - 0.25 each	200 - 220	30 - 50
Chicken, half	0.4 - 0.5 each	190 - 210	35 - 50
Chicken, poulard	1 - 1.5	190 - 210	50 - 70
Duck	1.5 - 2	180 - 200	80 - 100
Goose	3.5 - 5	160 - 180	120 - 180
Turkey	2.5 - 3.5	160 - 180	120 - 150
Turkey	4 - 6	140 - 160	150 - 240

## Fish (steamed)

Use the function: Conventional Cooking / Top / Bottom Heat.

Food	Quantity (kg)	Temperature (°C)	Time (min)
Whole fish	1 - 1.5	210 - 220	40 - 60

### 11.13 Grilling

Place a pan on the first shelf position to collect fat.

Preheat the empty oven before cooking.

Grill only thin pieces of meat or fish.

## Grilling

Food	Temperature (°C)	Time (min)		Shelf position
		1st side	2nd side	
Roast beef	210 - 230	30 - 40	30 - 40	2
Beef fillet	230	20 - 30	20 - 30	3
Pork loin	210 - 230	30 - 40	30 - 40	2
Veal loin	210 - 230	30 - 40	30 - 40	2
Lamb saddle	210 - 230	25 - 35	20 - 25	3
Whole fish, 0.5 kg - 1 kg	210 - 230	15 - 30	15 - 30	3 / 4

## 11.14 Frozen Foods

Use the function: True Fan Cooking.

Food	Temperature (°C)	Time (min)	Shelf position
Pizza, frozen	200 - 220	15 - 25	2
Pizza American, frozen	190 - 210	20 - 25	2
Pizza, chilled	210 - 230	13 - 25	2
Pizza snacks, frozen	180 - 200	15 - 30	2
French fries, thin	200 - 220	20 - 30	3
French fries, thick	200 - 220	25 - 35	3
Wedges / Croquettes	220 - 230	20 - 35	3
Hash browns	210 - 230	20 - 30	3
Lasagne / Cannelloni, fresh	170 - 190	35 - 45	2
Lasagne / Cannelloni, frozen	160 - 180	40 - 60	2
Baked cheese	170 - 190	20 - 30	3
Chicken wings	190 - 210	20 - 30	2

## 11.15 Defrost

Remove the food packaging and put the food on a plate.

Use the first shelf position.

Do not cover the food, as this can extend the defrost time.

For large portions of food place an upturned empty plate on the bottom of the oven cavity. Put the food in a deep plate or dish and set it on top of the plate inside the oven. Remove shelf supports if necessary.

Food	Quantity (kg)	Defrosting time (min)	Further defrosting time (min)
Chicken, turn halfway through	1	100 - 140	20 - 30
Meat, turn halfway through	1	100 - 140	20 - 30
Trout	0.15	25 - 35	10 - 15
Strawberries	0.3	30 - 40	10 - 20
Butter	0.25	30 - 40	10 - 15

Food	Quantity (kg)	Defrosting time (min)	Further defrosting time (min)
Cream, whip the cream when still slightly frozen in places	2 x 0.2	80 - 100	10 - 15
Gateau	1.4	60	60

### 11.16 Preserving - Bottom Heat

- Use only preserve jars of the same dimensions available on the market.
- Do not use jars with twist-off and bayonet type lids or metal tins.
- Use the first shelf from the bottom for this function.
- Put no more than six one-litre preserve jars on the baking tray.
- Fill the jars equally and close with a clamp.
- The jars cannot touch each other.
- Put approximately 1/2 litre of water into the baking tray to give sufficient moisture in the oven.
- When the liquid in the jars starts to simmer (after approximately 35 - 60 minutes with one-litre jars), stop the oven or decrease the temperature to 100 °C (see the table).

#### Soft fruit

Food	Temperature (°C)	Cooking time until simmering (min)	Continue to cook at 100 °C (min)
Strawberries / Blueberries / Raspberries / Ripe gooseberries	160 - 170	35 - 45	-

#### Stone fruit

Food	Temperature (°C)	Cooking time until simmering (min)	Continue to cook at 100 °C (min)
Pears / Quinces / Plums	160 - 170	35 - 45	10 - 15

#### Vegetables

Food	Temperature (°C)	Cooking time until simmering (min)	Continue to cook at 100 °C (min)
Carrots <sup>1)</sup>	160 - 170	50 - 60	5 - 10
Cucumbers	160 - 170	50 - 60	-
Mixed pickles	160 - 170	50 - 60	5 - 10
Kohlrabi / Peas / Asparagus	160 - 170	50 - 60	15 - 20

<sup>1)</sup> Leave standing in the oven after it is deactivated.

## 11.17 Drying - True Fan Cooking

Cover trays with grease proof paper or baking parchment.

For a better result, stop the oven halfway through the drying time, open the door and let it cool down for one night to complete the drying.

Vegetables

For one tray use the third shelf position.

For 2 trays use the first and fourth shelf position.

Food	Temperature (°C)	Time (h)
Beans	60 - 70	6 - 8
Peppers	60 - 70	5 - 6
Vegetables for soup	60 - 70	5 - 6

Food	Temperature (°C)	Time (h)
Mushrooms	50 - 60	6 - 8
Herbs	40 - 50	2 - 3

Fruit

Set the temperature to 60 - 70 °C.

For one tray use the third shelf position.

For 2 trays use the first and fourth shelf position.

Food	Time (h)
Plums	8 - 10
Apricots	8 - 10
Apple slices	6 - 8
Pears	6 - 9

## 11.18 Food Sensor

Beef	Food core temperature (°C)		
	Rare	Medium	Well done
Roast beef	45	60	70
Sirloin	45	60	70

Beef	Food core temperature (°C)		
	Less	Medium	More
Meatloaf	80	83	86

Pork	Food core temperature (°C)		
	Less	Medium	More
Ham / Roast	80	84	88
Saddle chop / Pork loin, smoked / Pork loin, poached	75	78	82

Veal	Food core temperature (°C)		
	Less	Medium	More
Roast veal	75	80	85
Veal knuckle	85	88	90

<b>Mutton / lamb</b>	<b>Food core temperature (°C)</b>		
	<b>Less</b>	<b>Medium</b>	<b>More</b>
Mutton leg	80	85	88
Mutton saddle	75	80	85
Roast lamb / Lamb leg	65	70	75

<b>Game</b>	<b>Food core temperature (°C)</b>		
	<b>Less</b>	<b>Medium</b>	<b>More</b>
Hare saddle / Venison saddle	65	70	75
Hare leg / Hare, whole / Venison leg	70	75	80

<b>Poultry</b>	<b>Food core temperature (°C)</b>		
	<b>Less</b>	<b>Medium</b>	<b>More</b>
Chicken	80	83	86
Duck, whole / half / Turkey, whole / breast	75	80	85
Duck, breast	60	65	70

<b>Fish (salmon, trout, zander)</b>	<b>Food core temperature (°C)</b>		
	<b>Less</b>	<b>Medium</b>	<b>More</b>
Fish, whole / large / steamed / Fish, whole / large / roasted	60	64	68

<b>Casseroles - Precooked vegetables</b>	<b>Food core temperature (°C)</b>		
	<b>Less</b>	<b>Medium</b>	<b>More</b>
Zucchini casserole / Broccoli casserole / Fennel casserole	85	88	91

<b>Casseroles - Savoury</b>	<b>Food core temperature (°C)</b>		
	<b>Less</b>	<b>Medium</b>	<b>More</b>
Cannelloni / Lasagne / Pasta bake	85	88	91

Casseroles - Sweet	Food core temperature (°C)		
	Less	Medium	More
White bread casserole with / without fruit / Rice porridge casserole with / without fruit / Sweet noodle casserole	80	85	90

## 11.19 Information for test institutes

Tests according to EN 60350 and IEC 60350.

Baking on one level. Baking in tins

Food	Function	Temperature (°C)	Time (min)	Shelf position
Fatless sponge cake	True Fan Cooking	140 - 150	35 - 50	2
Fatless sponge cake	Conventional Cooking / Top / Bottom Heat	160	35 - 50	2
Apple pie, 2 tins Ø20 cm	True Fan Cooking	160	60 - 90	2
Apple pie, 2 tins Ø20 cm	Conventional Cooking / Top / Bottom Heat	180	70 - 90	1

Baking on one level. Biscuits  
Use the third shelf position.

Food	Function	Temperature (°C)	Time (min)
Short bread / Pastry strips	True Fan Cooking	140	25 - 40
Short bread / Pastry strips, preheat the empty oven	Conventional Cooking / Top / Bottom Heat	160	20 - 30
Small cakes, 20 per tray, preheat the empty oven	True Fan Cooking	150	20 - 35
Small cakes, 20 per tray, preheat the empty oven	Conventional Cooking / Top / Bottom Heat	170	20 - 30

## Multilevel Baking. Biscuits

Food	Function	Temperature (°C)	Time (min)	Shelf position	
				2 positions	3 positions
Short bread / Pastry strips	True Fan Cooking	140	25 - 45	1 / 4	1 / 3 / 5
Small cakes, 20 per tray, preheat the empty oven	True Fan Cooking	150	23 - 40	1 / 4	-

## Grilling

Preheat the empty oven for 5 minutes.

Grill with the maximum temperature setting.

Food	Function	Time (min)	Shelf position
Toast	Grilling	1 - 3	5
Beef steak, turn halfway through	Grilling	24 - 30	4

## 12. CARE AND CLEANING

**WARNING!**

Refer to Safety chapters.

### 12.1 Notes on cleaning



#### Cleaning Agents

Clean the front of the oven with a soft cloth with warm water and a mild cleaning agent.

To clean metal surfaces, use a dedicated cleaning agent.

Clean stubborn stains with a special oven cleaner.



#### Everyday Use

Clean the oven cavity after each use. Fat accumulation or other food remains may cause fire. The risk is higher for the grill pan.

Dry the cavity with a soft cloth after each use.



#### Accessories

Clean all accessories after each use and let them dry. Use a soft cloth with warm water and a cleaning agent. Do not clean the accessories in a dishwasher.

Do not clean the non-stick accessories using aggressive agents, sharp-edged objects or in a dishwasher

## 12.2 Cleaning the cavity embossment

The cleaning procedure removes limestone residue from the cavity embossment after cooking with steam.

**i** For the function: True Fan Cooking PLUS we recommend to do the cleaning procedure at least every 5 - 10 cooking cycles.

1. Put 250 ml of white vinegar into the cavity embossment at the bottom of the oven.  
Use maximum 6% vinegar without any additives.
2. Let the vinegar dissolve the residual limestone at the ambient temperature for 30 minutes.
3. Clean the cavity with warm water and a soft cloth.

## 12.3 Removing the shelf supports

To clean the oven, remove the shelf supports.

**!** **CAUTION!** Be careful when you remove the shelf supports.

1. Pull the front of the shelf support away from the side wall.

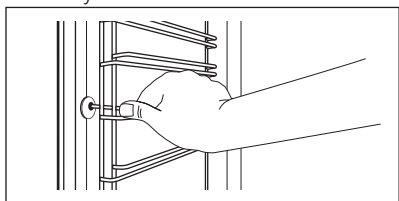

2. Pull the rear end of the shelf support away from the side wall and remove it.

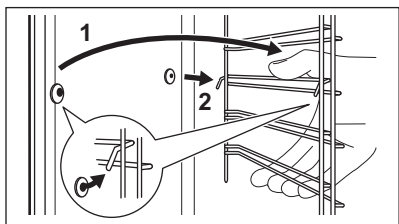

Install the removed accessories in the opposite sequence.

## 12.4 Pyrolysis

**!** **CAUTION!** Do not start the Pyrolysis if the Plus Steam button is pressed in.

**!** **CAUTION!** Remove all accessories and removable shelf supports.

**i** Do not start the Pyrolysis if you did not fully close the oven door. In some models, the display shows "C3" when this error occurs.

**!** **WARNING!** The oven becomes very hot. There is a risk of burns.

**!** **CAUTION!** If there are other appliances installed in the same cabinet, do not use them when the Pyrolysis function operates. It can cause damage to the appliance.





1. Wipe out the cavity with a wet, soft cloth.
2. Clean the inner side of the door with hot water, so that the residues do not burn from the hot air.
3. Set the Pyrolysis function. Refer to "Daily use" chapter, "Oven Functions".
4. When  $\rightarrow|$  flashes, press  $+$  or  $-$  to set the pyrolysis duration:

Option	Description
P1	Light cleaning. Duration: 1 h 30 min.
P2	Normal cleaning. Duration: 3 h.

After 2 seconds the pyrolysis starts.

You can use the END function to delay the start of the cleaning.



During the pyrolysis the oven lamp is off.

- To change the default length of the pyrolysis (P1 or P2), press  to set , and then press  or .
- When the oven is at the set temperature, the door locks. The display shows  and the bars of the heat indicator until the door unlocks.
- When pyrolysis is completed, the display shows the time of day. The oven door stays locked.
- When the oven is cool again, the door unlocks.

## 12.5 Cleaning reminder

To remind you that the pyrolysis is necessary, PYR flashes in the display for 10 seconds after each activation and deactivation of the oven.

### The cleaning reminder goes out:

- after the end of the pyrolysis.
- if you press  and  at the same time while PYR flashes in the display.

## 12.6

The number of glass panels is different for different models.

- Open the door fully.
- Fully press the clamping levers (A) on the two door hinges.

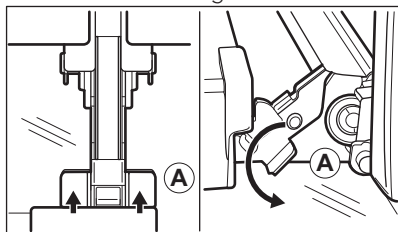

- Close the oven door to the first opening position (approximately 70° angle).
- Hold the door with one hand on each side and pull it away from the oven at an upwards angle.

- Put the door with the outer side down on a soft cloth on a stable surface.
- Hold the door trim (B) on the top edge of the door at the two sides and push inwards to release the clip seal.

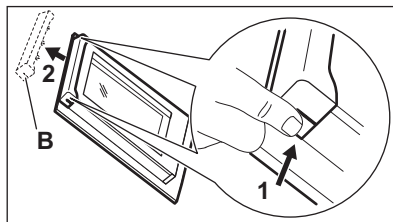

- Pull the door trim to the front to remove it.
- Hold the door glass panels on their top edge one by one and pull them up out of the guide.

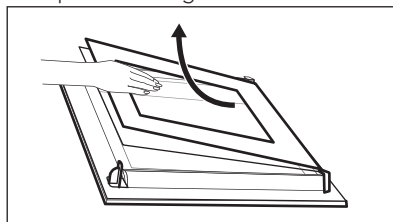

- Clean the glass panel with water and soap. Dry the glass panel carefully. When the cleaning is completed, do the above steps in the opposite sequence. Install the smaller panel first, then the larger and the door.



### WARNING!

Make sure that the glasses are inserted in the correct position otherwise the surface of the door may overheat.

Make sure that you put the glass panels (C, B and A) back in the correct sequence. First, insert panel C, which has a square printed on the left side and a triangle on the right side. You will also find those symbols embossed on the door frame. The triangle symbol on the glass must match the triangle on the door frame, and the square symbol must match the square. After that insert the other two glass panels.

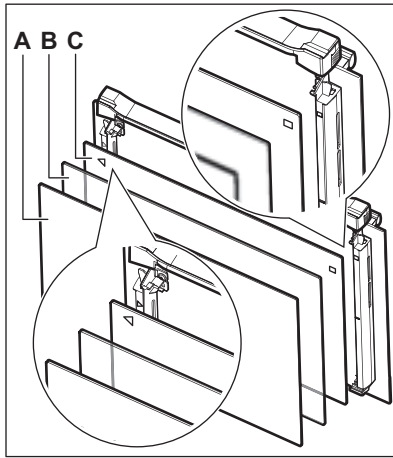

## 12.7 Replacing the lamp



**WARNING!**  
Risk of electric shock.  
The lamp can be hot.

1. Turn off the oven.  
Wait until the oven is cooled down.
2. Disconnect the oven from the mains.
3. Put a cloth on the bottom of the cavity.

### The top lamp

1. Turn the lamp glass cover to remove it.

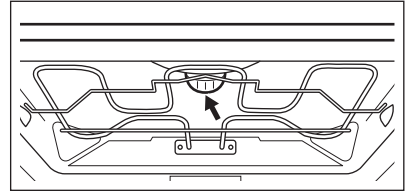

2. Clean the glass cover.
3. Replace the lamp with a suitable 300 °C heat-resistant lamp.
4. Install the glass cover.

## 13. TROUBLESHOOTING



**WARNING!**  
Refer to Safety chapters.

### 13.1 What to do if...

Problem	Possible cause	Remedy
You cannot activate or operate the oven.	The oven is not connected to an electrical supply or it is connected incorrectly.	Check if the oven is correctly connected to the electrical supply (refer to the connection diagram if available).
The oven does not heat up.	The oven is deactivated.	Activate the oven.
The oven does not heat up.	The clock is not set.	Set the clock.
The oven does not heat up.	The necessary settings are not set.	Make sure that the settings are correct.
The oven does not heat up.	The automatic switch-off is activated.	Refer to "Automatic switch-off".
The oven does not heat up.	The Child Lock is on.	Refer to "Using the Child Lock".
The oven does not heat up.	The door is not closed correctly.	Fully close the door.

<b>Problem</b>	<b>Possible cause</b>	<b>Remedy</b>
The oven does not heat up.	The fuse is blown.	Make sure that the fuse is the cause of the malfunction. If the fuse is blown again and again, contact a qualified electrician.
The lamp does not operate.	The lamp is defective.	Replace the lamp.
The core temperature sensor does not operate.	The plug of the core temperature sensor is not correctly installed into the socket.	Put the plug of the core temperature sensor as far as possible into the socket.
Steam and condensation settle on the food and in the cavity of the oven.	You left the dish in the oven for too long.	Do not leave the dishes in the oven for longer than 15 - 20 minutes after the cooking process ends.
The display shows "C2".	You want to start the Pyrolysis or Defrost function, but you did not remove the core temperature sensor plug from the socket.	Remove the core temperature sensor plug from the socket.
The display shows "C3".	The cleaning function does not operate. You did not fully close the door, or the door lock is defective.	Fully close the door.
The display shows "F102".	<ul style="list-style-type: none"> <li>You did not fully close the door.</li> <li>The door lock is defective.</li> </ul>	<ul style="list-style-type: none"> <li>Fully close the door.</li> <li>Deactivate the oven with the house fuse or the safety switch in the fuse box and activate it again.</li> <li>If the display shows "F102" again, contact the Customer Care Department.</li> </ul>
The display shows an error code that is not in this table.	There is an electrical fault.	<ul style="list-style-type: none"> <li>Deactivate the oven with the house fuse or the safety switch in the fuse box and activate it again.</li> <li>If the display shows the error code again, contact the Customer Care Department.</li> </ul>
There is no good cooking performance using the function: True Fan Cooking PLUS.	You did not turn on correctly the function: True Fan Cooking PLUS with the Plus Steam.	Refer to "Activating the function: True Fan Cooking PLUS".

<b>Problem</b>	<b>Possible cause</b>	<b>Remedy</b>
There is no good cooking performance using the function: True Fan Cooking PLUS.	You did not fill the cavity embossment with water.	Refer to "Activating the function: True Fan Cooking PLUS".
You want to activate the True Fan Cooking PLUS function, but the Plus Steam indicator does not switch on.	You did not select the heating function that support Plus Steam.	Refer to "Activating the function: True Fan Cooking PLUS".
You want to activate the True Fan Cooking PLUS function, but the Plus Steam indicator does not switch on.	The Plus Steam does not work.	Deactivate the appliance with the house fuse or the safety switch in the fuse box and activate it again. Refer to "Activating the function: True Fan Cooking PLUS".
You want to activate the cleaning function, but the display shows "C4".	The Plus Steam is pressed.	Press the Plus Steam again.
The water in the cavity embossment does not boil.	The temperature is too low.	Set the temperature at least to 110 °C. Refer to "Hints and tips" chapter.
The water comes out of the cavity embossment.	There is too much water in the cavity embossment.	Deactivate the oven and make sure that the appliance is cold. Wipe the water with a cloth or sponge. Add the correct amount of water to the cavity embossment. Refer to the specific procedure.

Problem	Possible cause	Remedy
The appliance is activated and does not heat up. The fan does not operate. The display shows " <b>Demo</b> ".	The demo mode is activated.	<ol style="list-style-type: none"> <li>1. Deactivate the oven.</li> <li>2. Press and hold the button <b>+</b>.</li> <li>3. The first digit on the display and <b>Demo</b> indicator start to blink.</li> <li>4. Enter the code 2468 by pressing the buttons <b>+</b> or <b>-</b> to change the values and press  to confirm.</li> <li>5. The next digit starts to blink.</li> <li>6. <b>Demo</b> mode deactivates when you confirm the last digit and the code is correct.</li> </ol>

## 13.2 Service data

If you cannot find a solution to the problem yourself, contact your dealer or an Authorised Service Centre.

The necessary data for the service centre is on the rating plate. The rating plate is

on the front frame of the oven cavity. Do not remove the rating plate from the oven cavity.

### We recommend that you write the data here:

Model (MOD.)	.....
Product number (PNC)	.....
Serial number (S.N.)	.....

# 14. ENERGY EFFICIENCY

## 14.1 Energy saving



The oven contains features which help you save energy during everyday cooking.

Make sure that the oven door is closed properly when the oven operates. Do not open the door too often during cooking. Keep the door gasket clean and make sure it is well fixed in its position.

Use metal cookware to improve energy saving.

When possible, do not preheat the oven before cooking.

Keep breaks between baking as short as possible when you prepare a few dishes at one time.

### Cooking with fan

When possible, use the cooking functions with fan to save energy.

**Residual heat**

If a programme with the Duration or End Time selection is activated and the cooking time is longer than 30 minutes, the heating elements automatically turn off earlier in some oven functions.

The fan and lamp continue to operate. When you turn off the oven, the display shows the residual heat. You can use that heat to keep the food warm.

When the cooking duration is longer than 30 minutes, reduce the oven temperature to minimum 3 - 10 minutes before the end of cooking. The residual heat inside the oven will continue to cook.

Use the residual heat to warm up other dishes.

**Keep food warm**

Choose the lowest possible temperature setting to use residual heat and keep a meal warm. The residual heat indicator or temperature appears on the display.

**Moist Fan Baking**

Function designed to save energy during cooking.

When you use this function the lamp automatically turns off after 30 seconds.

## 15. WARRANTY

FOR SALES IN AUSTRALIA AND NEW ZEALAND

ALL AEG BRANDED APPLIANCES

**This document sets out the terms and conditions of the product warranties for AEG Appliances. It is an important document. Please keep it with your proof of purchase documents in a safe place for future reference should there be a manufacturing defect in your Appliance. This warranty is in addition to other rights you may have under the Australian Consumer Law.**

**1. In this warranty:**

- a) 'ACL' or 'Australian Consumer Law' means Schedule 2 to the Competition and Consumer Act 2010;
- b) 'Appliance' means any Electrolux product purchased by you and accompanied by this document;
- c) 'ASC' means Electrolux's authorised serviced centres;
- d) 'AEG' is the brand controlled by Electrolux Home Products Pty Ltd of 163 O'Riordan Street, Mascot NSW 2020, ABN 51 004 762 341 in respect of Appliances purchased in Australia and Electrolux (NZ) Limited (collectively "Electrolux") of 3-5 Niall Burgess Road, Mount Wellington, in respect of

Appliances purchased in New Zealand;

- e) 'Warranty Period' means the period specified in clause 3 of this warranty;
  - f) 'you' means the purchaser of the Appliance not having purchased the Appliance for re-sale, and 'your' has a corresponding meaning.
2. **Application:** This warranty only applies to new Appliances, purchased and used in Australia or New Zealand and is in addition to (and does not exclude, restrict, or modify in any way) other rights and remedies under a law to which the Appliances or services relate, including any non-excludable statutory guarantees in Australia and New Zealand.
  3. **Warranty Period:** Subject to these terms and conditions, this warranty continues for in Australia for a period of 60 months and in New Zealand for a period of 60 months, following the date of original purchase of the Appliance.
  4. **Repair or replace warranty:** During the Warranty Period, Electrolux or its ASC will, at no extra charge if your Appliance is readily accessible for service, without special equipment and subject to these terms and conditions, repair or replace any parts which it considers to be

defective. Electrolux may, in its absolute discretion, choose whether the remedy offered for a valid warranty claim is repair or replacement. Electrolux or its ASC may use refurbished parts to repair your Appliance. You agree that any replaced Appliances or parts become the property of Electrolux.

**5. Travel and transportation costs:**

Subject to clause 7, Electrolux will bear the reasonable cost of transportation, travel and delivery of the Appliance to and from Electrolux or its ASC. Travel and transportation will be arranged by Electrolux as part of any valid warranty claim.

**6. Proof of purchase** is required before you can make a claim under this warranty.

**7. Exclusions:** You may not make a claim under this warranty unless the defect claimed is due to faulty or defective parts or workmanship. This warranty does not cover:

- a) light globes, batteries, filters or similar perishable parts;
- b) parts and Appliances not supplied by Electrolux;
- c) cosmetic damage which does not affect the operation of the Appliance;
- d) damage to the Appliance caused by:
  - negligence or accident;
  - misuse or abuse, including failure to properly maintain or service;
  - improper, negligent or faulty servicing or repair works done by anyone other than an Electrolux authorised repairer or ASC;
  - normal wear and tear;
  - power surges, electrical storm damage or incorrect power supply;
  - incomplete or improper installation;
  - incorrect, improper or inappropriate operation;
  - insect or vermin infestation;
  - failure to comply with any additional instructions supplied with the Appliance;

In addition, Electrolux is not liable under this warranty if:

- the Appliance has been, or Electrolux reasonably believes that the Appliance has been, used for purposes other than those for which the Appliance was intended, including where the Appliance has been used for any non-domestic purpose;
- the Appliance is modified without authority from Electrolux in writing;
- the Appliance’s serial number or warranty seal has been removed or defaced.

**8. How to claim under this warranty:**

To enquire about claiming under this warranty, please follow these steps:

- a. carefully check the operating instructions, user manual and the terms of this warranty;
- b. have the model and serial number of the Appliance available;
- c. have the proof of purchase (e.g. an invoice) available;
- d. telephone the numbers shown below.

**9. Australia:** For Appliances and services provided by Electrolux in Australia: Electrolux goods come with guarantees that cannot be excluded under the Australian Consumer Law. You are entitled to a replacement or refund for a major failure and for compensation for any other reasonably foreseeable loss or damage. You are also entitled to have the Appliance repaired or replaced if the Appliance fails to be of acceptable quality and the failure does not amount to a major failure. ‘Acceptable quality’ and ‘major failure’ have the same meaning as referred to in the ACL.

**10. New Zealand:** For Appliances and services provided by Electrolux in New Zealand, the Appliances come with a guarantee by Electrolux pursuant to the provisions of the Consumer Guarantees Act, the Sale of Goods Act and the Fair Trading Act. Where the Appliance was purchased in New Zealand for

commercial purposes the Consumer Guarantee Act does not apply.

**11. Confidentiality:** You accept that if you make a warranty claim, Electrolux and its agents including ASC may

exchange information in relation to you to enable Electrolux to meet its obligations under this warranty.

**Important Notice**

Before calling for service, please ensure that the steps listed in clause 8 above have been followed.

**SERVICE AUSTRALIA**  
aeg.com/au

<p style="text-align: center;"><b>FOR SERVICE</b></p> <p>or to find the address of your nearest authorised service centre in Australia</p> <p style="text-align: center;"><b>PLEASE CALL 1300 363 664</b></p> <p style="text-align: center;"><b>OR EMAIL</b></p> <p style="text-align: center;"><b>customercare@aegaustralia.com.au</b></p> <p style="text-align: center;"><small>For the cost of a local call (Australia only)</small></p>	<p style="text-align: center;"><b>FOR SPARE PARTS</b></p> <p>or to find the address of your nearest spare parts centre in Australia</p> <p style="text-align: center;"><b>PLEASE CALL 13 13 50</b></p> <p style="text-align: center;"><b>OR EMAIL</b></p> <p style="text-align: center;"><b>customercare@aegaustralia.com.au</b></p> <p style="text-align: center;"><small>For the cost of a local call (Australia only)</small></p>
---	--

**SERVICE NEW ZEALAND**  
aegnewzealand.co.nz

<p style="text-align: center;"><b>FOR SERVICE</b></p> <p>or to find the address of your nearest authorised service centre in New Zealand</p> <p style="text-align: center;"><b>PLEASE CALL 0800 234 234</b></p> <p style="text-align: center;"><b>OR EMAIL</b></p> <p style="text-align: center;"><b>customercare@electrolux.co.nz</b></p> <p style="text-align: center;"><small>(New Zealand only)</small></p>	<p style="text-align: center;"><b>FOR SPARE PARTS</b></p> <p>or to find the address of your nearest spare parts centre in New Zealand</p> <p style="text-align: center;"><b>PLEASE CALL 0800 10 66 20</b></p> <p style="text-align: center;"><b>OR EMAIL</b></p> <p style="text-align: center;"><b>customercare@electrolux.co.nz</b></p> <p style="text-align: center;"><small>(New Zealand only)</small></p>
---	---

AEG\_Warr\_May\_17

## 16. ENVIRONMENTAL CONCERNS

Recycle materials with the symbol . Put the packaging in relevant containers to recycle it. Help protect the environment and human health by recycling waste of electrical and electronic appliances. Do not dispose of

appliances marked with the symbol  with the household waste. Return the product to your local recycling facility or contact your municipal office.



**AEG**