

Manual for use and maintenance

RLINK
ONE



RLINK ONE

Wireless Communication

Ag/MIS/UmGB-2449-04/17 Rev 1.0
P/N: 116605



RLINK ONE

Manual for use and maintenance

Revision: 1.0 of 01. 2019

Ag/MIS/UmGB-2449-04/17 Rev 1.6 (MIS)

Product Software: Version 1.01

This manual for use and maintenance is an integral part of the apparatus together with the attached technical documentation.

This document is destined for the user of the apparatus: it may not be reproduced in whole or in part, committed to computer memory as a file or delivered to third parties without the prior authorization of the assembler of the system.

Munters reserves the right to effect modifications to the apparatus in accordance with technical and legal developments.

Index

<i>Chapter</i>		<i>page</i>
1	INTRODUCTION	5
	1.1 Disclaimer	5
	1.2 Introduction	5
	1.3 Notes	5
2	SAFETY ASPECTS	6
3	BEFORE USING	6
	3.1 What comes in the package	7
	3.2 System setup	7
	3.3 Unit Functionality	7
	3.3.1 Wireless Communication Functions	7
	3.3.2 Wired Communication Functions	11
4	RLINK ONE INSTALLATION OVERVIEW	12
	4.1 Dipswitches Locations	13
	4.2 LEDs Locations	14
5	RF TRANSMISSION QUALITY	15
6	INSTALLATION	18
	6.1 Preventing lightning damage	18
	6.2 Installing the units	19
	6.2.1 Mounting the units	19
	6.2.2 Placing the field units	20
	6.2.3 Testing the Signal Strength	21
	6.3 Wiring the RLINK ONE	23
	6.3.1 Wiring the office RLINK ONE	23
	6.3.2 Wiring the field RLINK ONE	26
	6.3.3 Powering the Unit	28
7	CONFIGURING THE UNIT	29
	7.1 Configuring the Wireless Communication	30
	7.1.1 Defining the Baud Rate	30
	7.1.2 Defining the Mode	31
	7.1.3 Defining the Power Level	32
	7.1.4 Defining the Channel	32
	7.1.5 Defining the IN2 Dipswitch	33
	7.2 Configuring the RS-485 Communication	34
	7.2.1 Introduction to Termination and 5V Setup	34
	7.2.2 Defining the 5V Status	38
	7.2.3 Defining the Termination	38
	7.2.4 Number of Controllers	39

8	TECHNICAL DATA -----	40
9	APPENDIX A: TROUBLESHOOTING -----	41
10	WARRANTY -----	43

1 Introduction

1.1 Disclaimer

Munters reserves the right to make alterations to specifications, quantities, dimensions etc. for production or other reasons, subsequent to publication. The information contained herein has been prepared by qualified experts within Munters. While we believe the information is accurate and complete, we make no warranty or representation for any particular purposes. The information is offered in good faith and with the understanding that any use of the units or accessories in breach of the directions and warnings in this document is at the sole discretion and risk of the user.

1.2 Introduction

Congratulations on your excellent choice of purchasing a RLINK ONE!
In order to realize the full benefit from this product it is important that it is installed, commissioned and operated correctly. Before installation or using the fan, this manual should be studied carefully. It is also recommended that it is kept safely for future reference. The manual is intended as a reference for installation, commissioning and day-to-day operation of the Munters Controllers.

1.3 Notes

Date of release: July 2010

Munters cannot guarantee to inform users about the changes or to distribute new manuals to them.

All rights reserved. No part of this manual may be reproduced in any manner whatsoever without the expressed written permission of Munters. The contents of this manual are subject to change without notice.

2 Safety aspects

- The COM connection for communications is not the shield wire. The COM, RX and TX wires must connect to each other at all controllers.
- To ensure product functionality, proper grounding of the RLINK One and controllers is essential. Review all instructions (mounting and wiring) before installing the unit.

3 Before using

The RLINK One Communication provides wireless communication between a user PC and the controller network. RLINK One operates at frequencies and power levels which do not require a license. RLINK One's options enable each user to configure the wireless and wired communication system that meets the farm's particular requirement.

Figure 1 illustrates a sample controller network utilizing the RLINK ONE. Office units are connected to a Farm Guard, Farm Communication Box, or USB RS-485 Driver. Connect the field unit to a controller

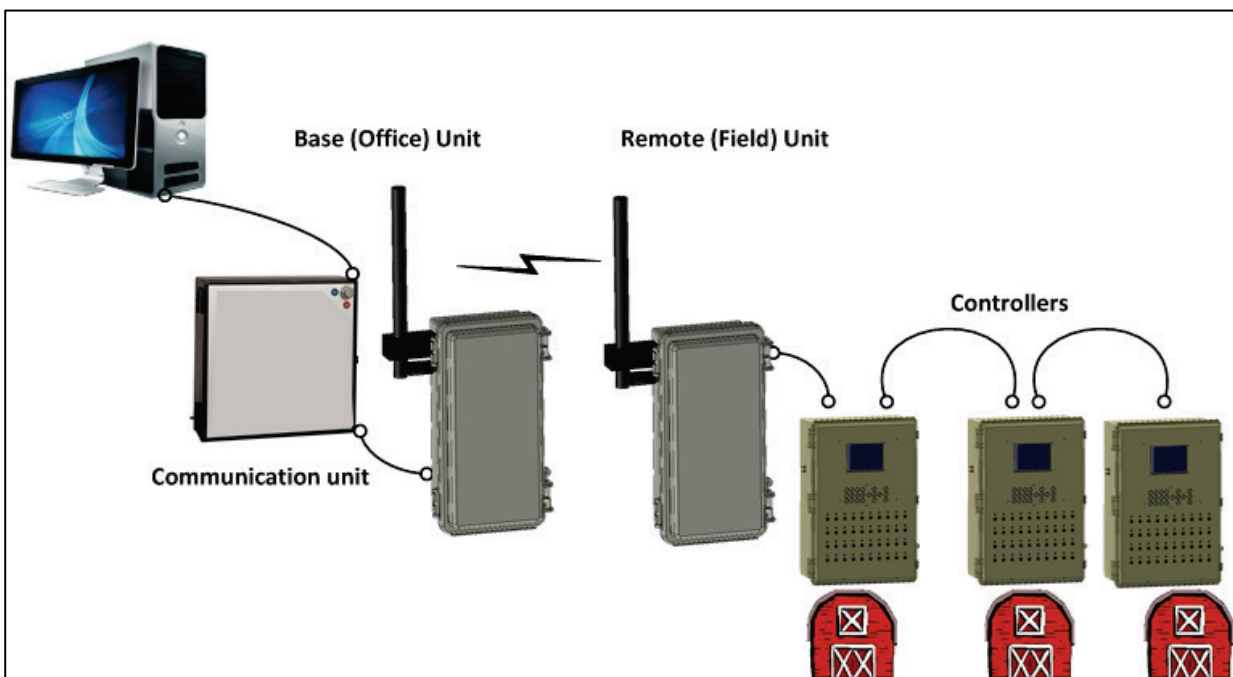

Figure 1: Sample Network

In a standard installation, RS-485 communication cable connects each controller to the network. In cases where a structure or a street divides one house from the next, RLINK One enables wireless connections.

NOTE The distance between the communication unit and the Base RLINK ONE can be quite long. There is no requirement that the two pieces of equipment be located in the same structure.

3.1 What comes in the package

The RLINK ONE package includes:

RLINK ONE unit



RG-58 cable
(option)



Omni-directional 2 dBi antenna

- 2 dBi
- 8 dBi (see Figure 18)



Antenna mounting
clip and screws
(comes with the
RG-58 cable)



12 VDC power supply



3.2 System setup

Before setting up your system check the following issues:

- **Country/State:** RLINK One supports different power levels (up to 1 watt) and frequencies (900/915 MHz). Before defining the RLINK One units' power levels and frequency, review your country's legal requirements as set forth by the local communication ministry.
- **Frequency and power levels:** All RLINK ONE units must use exactly the same frequency and power levels (check the RF modules).
- Munters recommends limiting each RLINK ONE system to 20 RLINK ONE units.

3.3 Unit Functionality

To ensure signal quality, system stability and signal quality, users configure RLINK One's functionality. Both wired and wireless functions need to be configured.

- Wireless Communication Functions
- Wired Communication Functions

3.3.1 Wireless Communication Functions

- Modes
- Baud Rate
- Channels
- Power Level
- Communication Protocol

3.3.1.1 Modes

RLINK One units function in different data modes, depending on the unit's location and the system setup. The user defines each unit's mode when setting up the system.

- **Base:** An RLINK One unit connected to the communication device is the Base.
- **Remote:** An RLINK One unit connected to a controller network is a Remote.
- **Repeater:** An RLINK unit which is used to boost the signal between the Base and Remote units is defined as Repeater.

NOTE Whether or not your system requires a Repeater depends on multiple factors. Consult with your dealer.

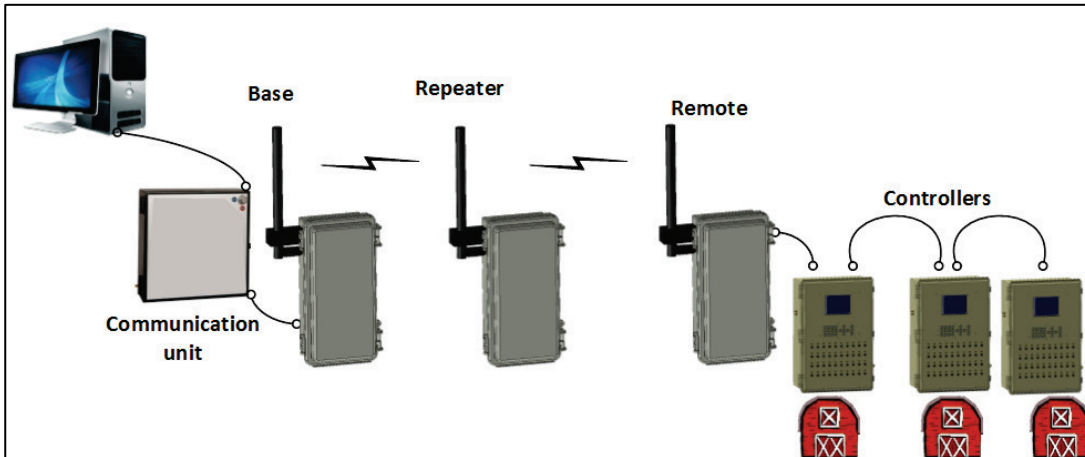

Figure 2: Base, Repeater, Remote Modes

- **Loopback:** RLINK One can be used to test signal strength when designing possible system architectures. In this mode, the Loopback unit transmits data to the Base (office) unit, enabling the user to verify signal strength and quality.

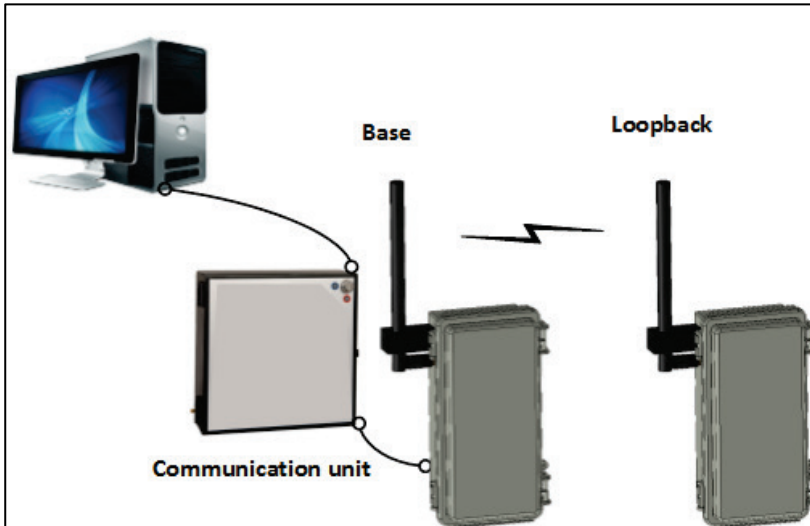

Figure 3: Loopback Mode

- Refer to Defining the Mode, page 31 and Testing the Signal Strength, page 21 for more information.

3.3.1.2 Baud Rate

RLINK One supports wireless baud rates ranging from 1200 BPS to 115200 BPS.

- Refer to Defining the Baud Rate, page 30 for more information.

NOTE The controllers and communication devices define the wired communication speeds.

3.3.1.3 Channels

A channel is an address available to the radio modem. For RLINK One units to communicate with each other, they must have the **same channel number** since each network uses a different hopping sequence. Use different channels to prevent modules from listening to transmissions from one another in the same network.

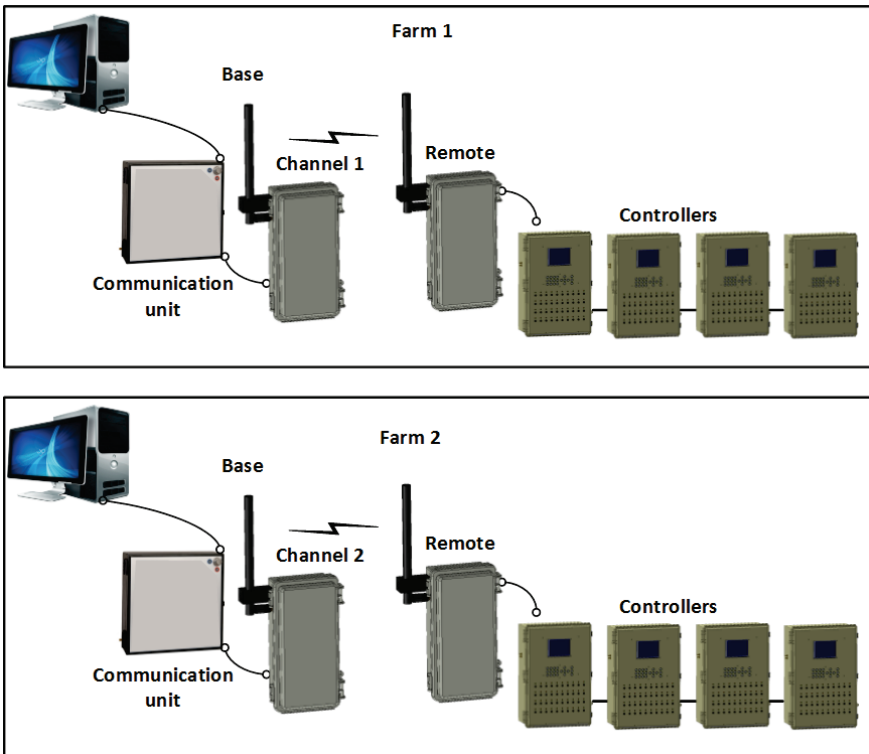

Figure 4: Channels in Adjoining Farms (example)

- Refer to Defining the Channel, page 32 for more information.

3.3.1.4 Power Level

Power levels provide an additional means of separating RF signals in adjoining networks. Even when different networks transmit on different channels, the signals themselves can mix and reduce the signal quality. By differentiating the power levels, the user can minimize mixing signals from adjoining farms.

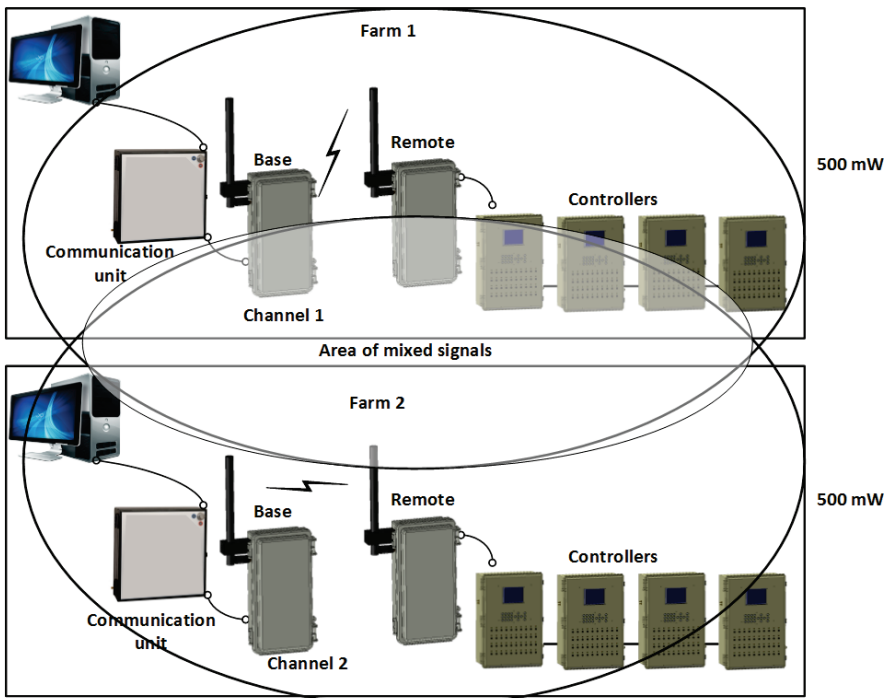

Figure 5: Power Levels Causing Overlapping Signals

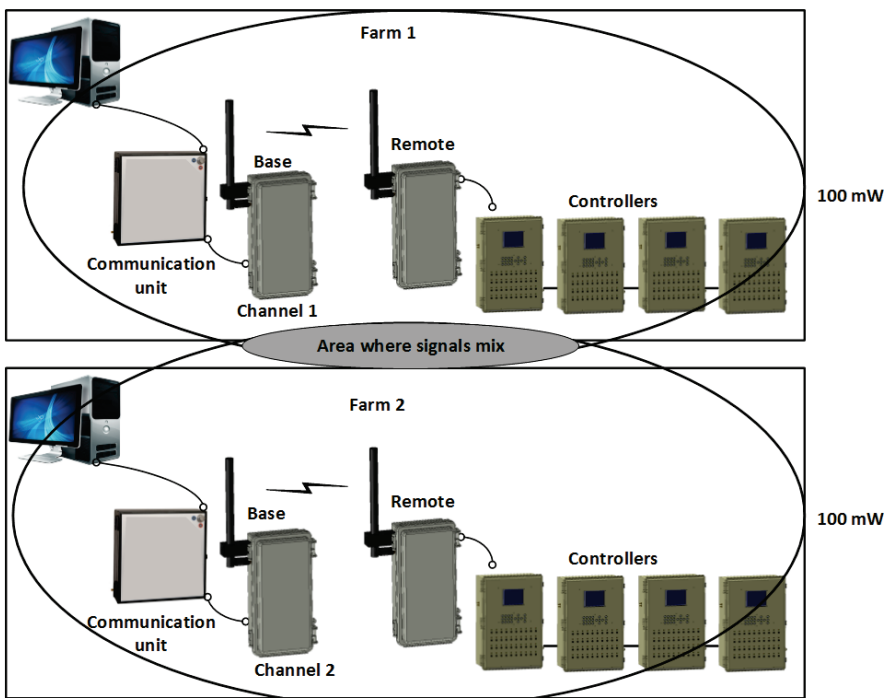

Figure 6: Minimized Signal Mixing

Refer to Defining the Power Level, page 32 for more information.

3.3.1.5 Communication Protocol

RLINK One transmits data packets using two different communication protocols, named Platinum and Gateway. Which communication protocol is used depends on the equipment used. Refer to Defining the Platinum/Gateway Protocol, page 33 for details.

3.3.1.6 Low Signal Protection

In cases where there is no incoming RF signal, RLINK One resets or reconfigures itself to ensure that all functions are operating properly. Refer to Freeze Protection, page 23 for details.

3.3.2 Wired Communication Functions

After connecting an RLINK to a controller or communication device, the user needs to configure the:

- 5V status (refer to page 38)
- Termination status (refer to page 38)

These functions help insure the quality of the signal transmission between the RLINK One and the communication units and controllers.

4 RLINK One Installation Overview

The following is an overview of the entire installation process.

- Review the factors involved in signal transmission quality (RF transmission quality, page 15)
- Review the factors involved in preventing lightning damage (Preventing lightning damage, page 18)
- Mount the RLINK One base unit in the office.
- Set the RLINK One Base unit to Base mode (Defining the Mode, page 31).
- Define the Base unit's other wireless settings (baud rate, power level, channel, communication protocol (Configuring the Wireless Communication, page 30).
- Define the Base unit's RS-485 settings (Configuring the RS-485 Communication, page 34).
- Press the Base unit's Configure button for five seconds. This generates a test signal.
- Define the Remote unit's wireless settings (baud rate, power level, channel, communication protocol (Configuring the Wireless Communication, page 30).
- Set the RLINK One Remote unit to Loopback mode (Defining the Mode, page 31).
- Place the Remote unit in the approximate installation location and test the RSSI signal (Testing the Signal Strength, page 21).
 - If the signal meets specifications, mount the Remote Unit. After placing the Remote Unit, redefine its mode as Remote.
 - If the signal does not meet specifications, adjust the Remote unit's location, the Base unit's location, or both and retest until you find a suitable spot. Redefine the unit as Remote.
- Repeat the testing procedure for each Remote unit.
- After testing all remote units, disconnect the Base unit's power source (or press the Reset button). This ceases the test signal.
- Define the Remote unit's RS-485 settings (Configuring the RS-485 Communication, page 34).
- Wire all RLINK One's to the communication units and controllers (Wiring the RLINK ONE, page 23).

4.1 Dipswitches Locations

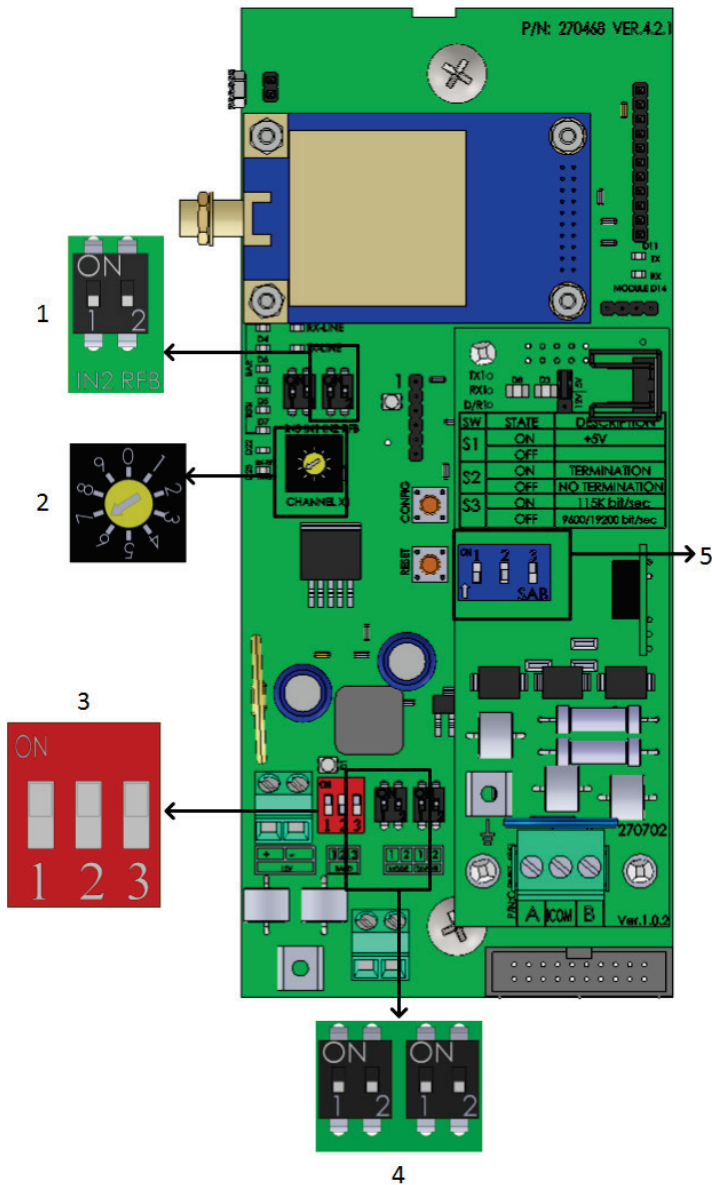

Figure 7: Dipswitch Locations

- 1: RFB Dipswitch (Expanding the Number of Channels, page 33)
- 2: Channel Potentiometer (Defining the Channel, page 32)
- 3: Baudrate (Defining the Baud Rate, page 30)
- 4: Mode/Power Level (Defining the Mode/Defining the Power Level, page 31)
- 5: Termination / 5V dipswitch (Configuring the RS-485 Communication, page 34)

4.2 LEDs Locations

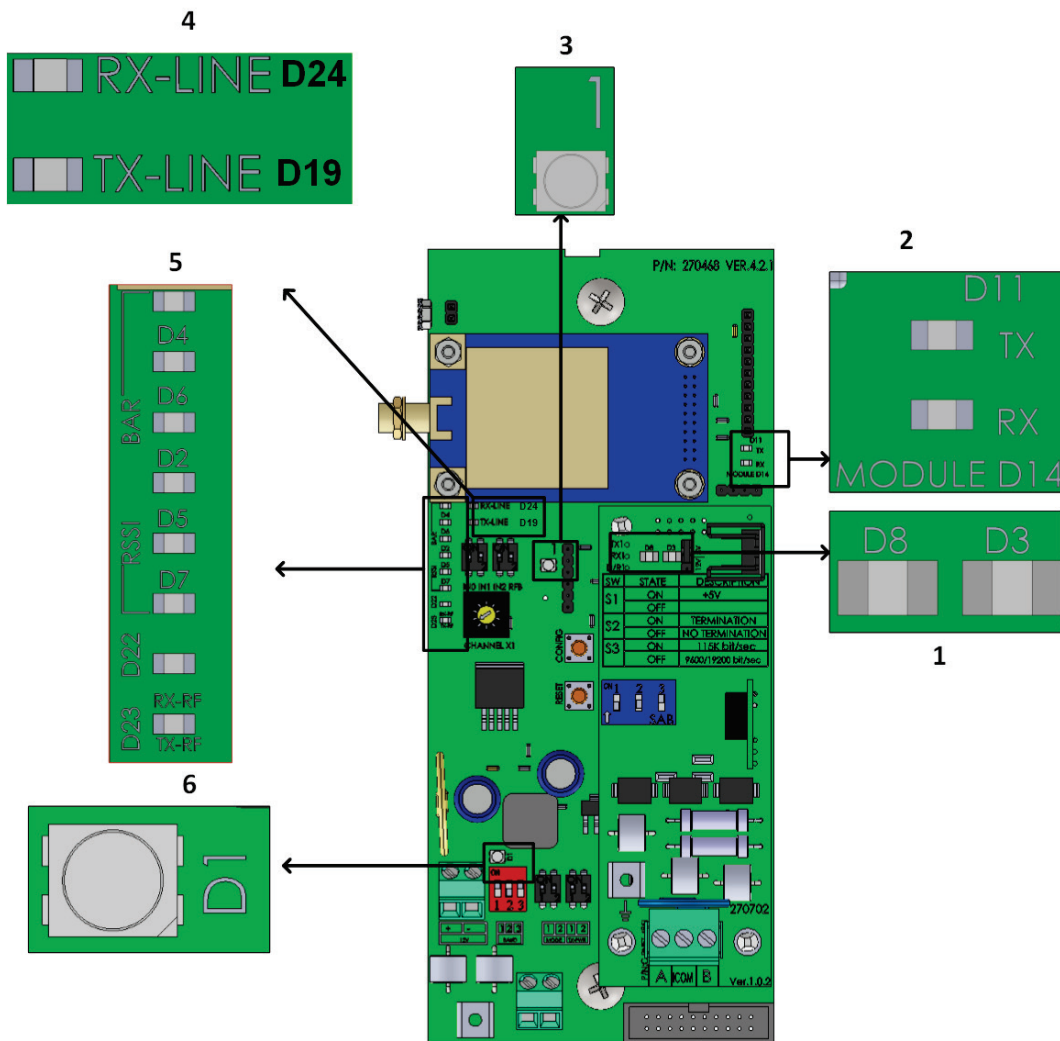

Figure 8: LEDs Locations

1: RLINK ONE to Controller/Farm Guard data flow indicator (refer to RLINK One to Farm Guard or Controllers LEDs (on communication **card**), page 41)

2: RLINK ONE - RLINK ONE data transmission (refer to RLINK One to RLINK One LEDs, page 41)

3: Channel expansion LED (Expanding the Number of Channels, page 33)

4: Internal RLINK ONE communication (refer to CPU - Modem Communication, page 42)

5: RF signal strength LEDs (Testing the Signal Strength, page 21)

6: D1 LED (Defining the Mode, page 31)

Refer to Appendix A: Troubleshooting, page 41 for more information on these LEDs functionality.

5 RF transmission quality

Various factors influence transmission distance including (but not excluded to) presence of buildings, trees, high power lines, electrical equipment, the weather and ambient RF noise. While there are factors beyond your control which affect transmission length and quality, you can improve them as follows:

- Attach the RLINK ONE directly to the antenna on a pole (Figure 9).
- Mount the antenna on a pole and connect it to the RLINK ONE using RF cable (Figure 10).

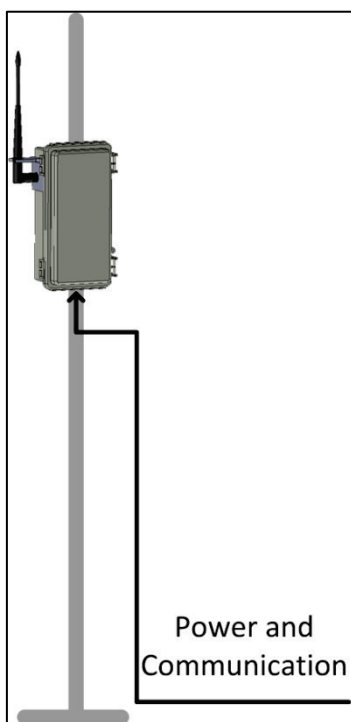

Figure 9: RLINK ONE Installed on a Pole

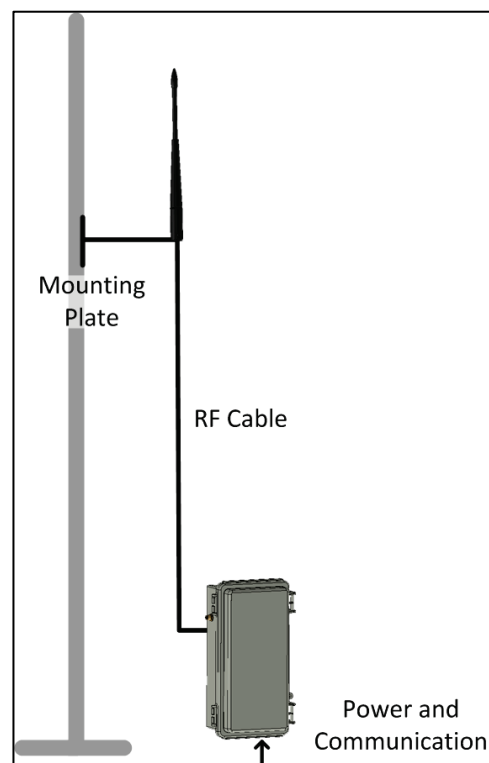

Figure 10: RLINK ONE Antenna Installed on a Pole (Recommended)

- In cases of poor reception, use a uni-directional antenna.
- Choosing to install a uni-directional antenna entails changes in the installation. Refer to Installing the unit, page 18.
- Maintain a clear "line of sight":
 - The antenna needs to be installed anywhere from 2 to 5 meters / 7 to 16 feet above ground. The exact height depends on the field conditions.
 - Place the radio units on the sides of the barns facing the main office.

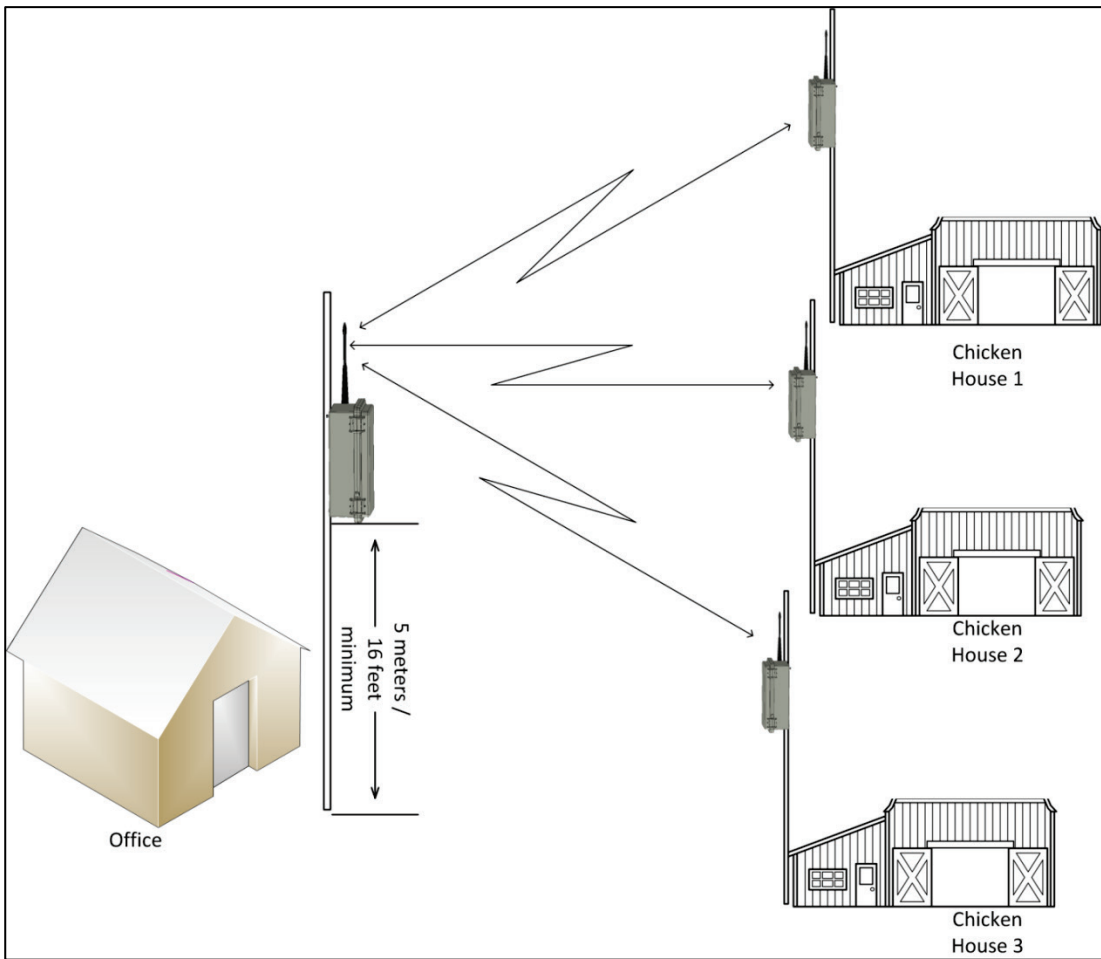

Figure 11: Placement on Adjacent Sides of Barn

- When using **metal poles**:
 - Ground it according to industry standards!
 - Install the RLINK ONE only on the side of the poles **facing** the main office. Signal strength **behind** the RLINK ONE is extremely poor (Figure 12).

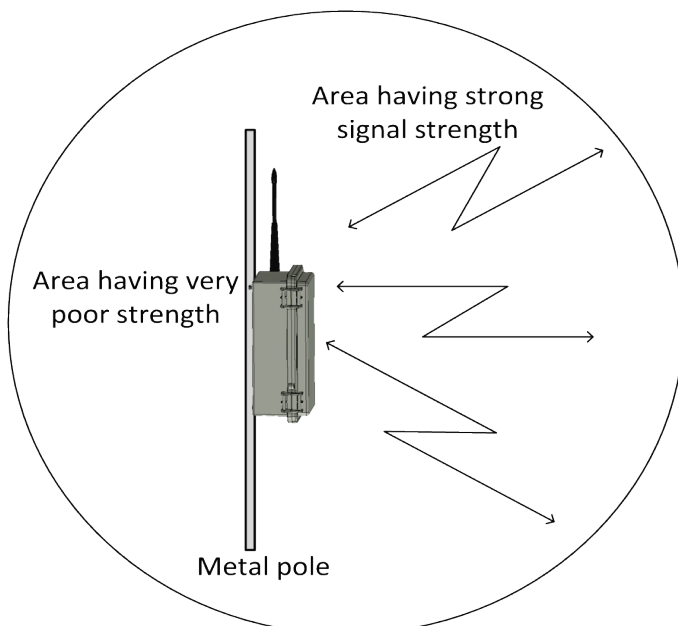

Figure 12: Transmission Area

- Ensure that there are no metal obstacles or power lines between the RLINK ONEs (Figure 13 and Figure 14). These objects create electromagnetic interference.

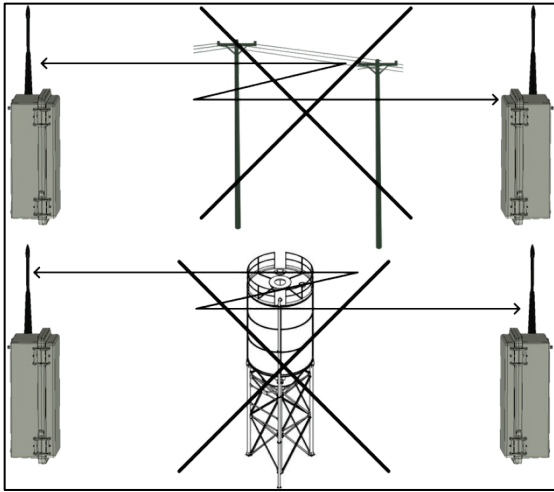

Figure 13: Obstacles in Path

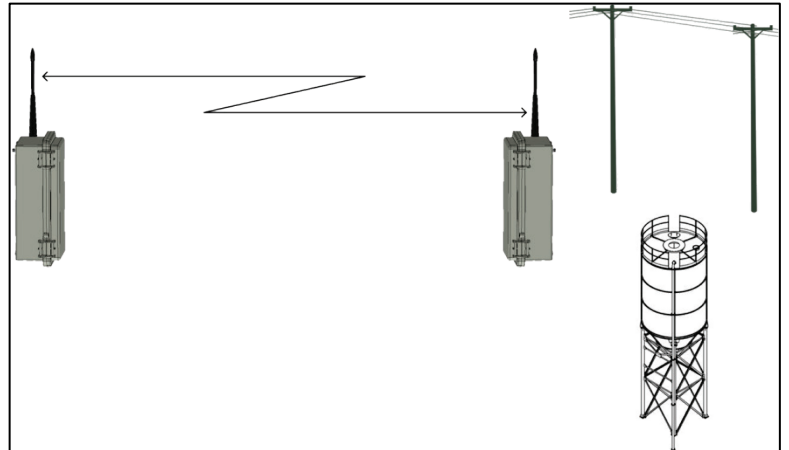

Figure 14: Clear Path

NOTE Given the number of factors that influence transmission distance, each installation is unique. Consult with your dealer regarding which options you require and how to install them.

6 Installation

The following sections detail the RLINK ONE installation and configuration.

- Preventing lightning damage
- Installing the units
- Wiring the RLINK ONE

NOTE After physically installing and wiring the units, configure the RLINK One's dipswitches. Refer to *Configuring the Unit*, page 29.

6.1 Preventing lightning damage

Lightning will attempt to find the shortest, easiest path to get to ground. When installing the unit, it is incumbent to ensure that the RLINK ONE is not this path.

Lightning can enter the RLINK ONE in three ways:

- Via the power supply
- Via the communication card
- Via the RF (antenna)

Therefore, Munters recommends the following steps when installing your units.

- Install a 25 – 50 watt isolation transformer in front of the RLINK ONE power supply.

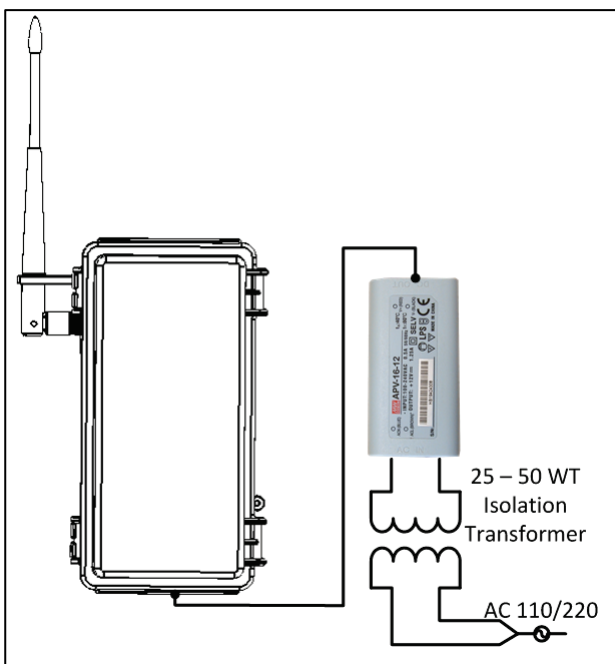

Figure 15: Isolation Transformer set up

- Make a proper safety GND connection to the C-RNET-485i card at RLINK One. Refer to Figure 27, Figure 28, and Figure 29

- Antenna pole (refer to Figure 16):
 - Ideally the pole should be an isolated material (for example plastic or wood).
 - Place the RLINK ONE unit so that:
 - The antenna is at least one foot below the pole top (when using a metal pole).
 - The unit is at least three feet above the roof.

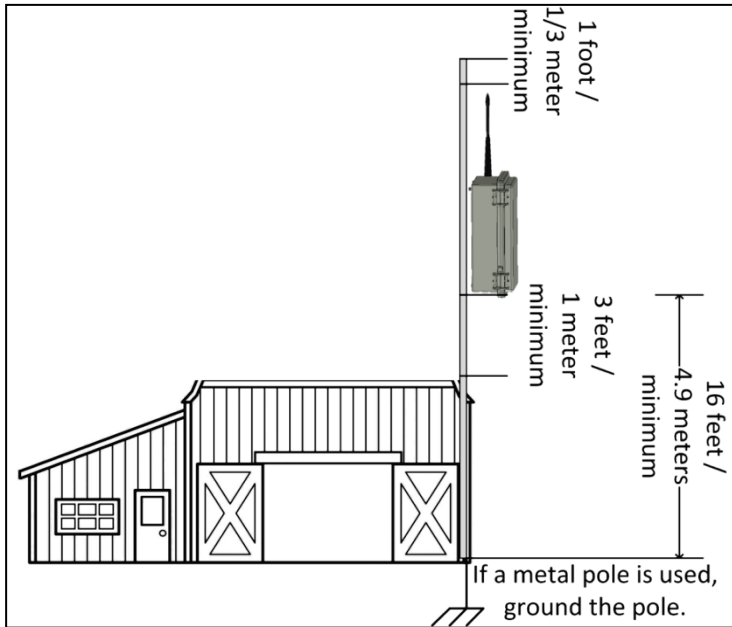

Figure 16: Lightning rod setup

CAUTION There may be other steps you can take to prevent lightning damage to your equipment such as installing lightning dissipators. Munters recommends following industry best practices as speaking with your local extension agent.

6.2 Installing the units

- Mounting the units
- Placing the field units
- Testing the Signal Strength

6.2.1 Mounting the units

NOTE Before installing your units, refer to *Preventing Lightning Damage*, page 18, which provides important installation tips

1. Mount the RLINK ONE:
 - On a wall, using the supplied screws and plates, through the mounting holes.
 - On a pole.
2. Place the required cables through the cable holders at the bottom of the unit.
3. Connect the antenna to the unit.
 - Option 1: Connect the antenna via the supplied RG-58 cable and antenna mounting clip (Figure 9).
 - Option 2: Replace the antenna with a user-supplied uni-directional antenna (connected directly to the unit or via a cable).

- Option 3: Connect the antenna directly to the unit (Figure 17).
 - Slip the antenna through the antenna lock.
 - Attach the antenna to the connector.

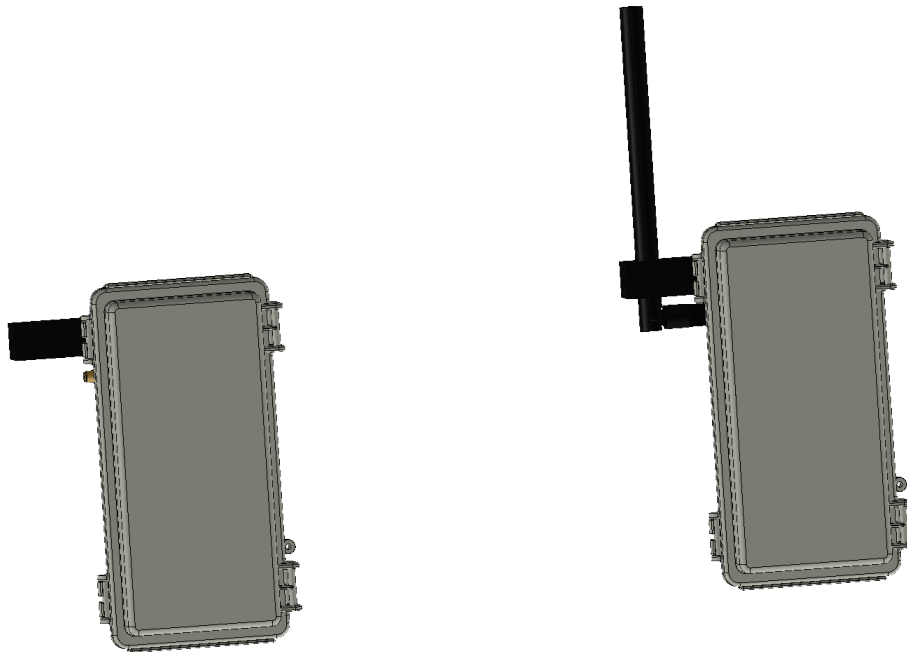

Figure 17: Antenna Placement

6.2.2 Placing the field units

- When the supplied antenna is used, you can place the RLINK ONEs and controllers anywhere, 360 degrees around the central RLINK ONE (Figure 18).

NOTE If you are using a metal pole, refer to Figure 12.

Munters uni-directional antenna has a 21° beam-angle. When using other uni-directional antenna, refer to the manufacturers beam width specification (Figure 19).

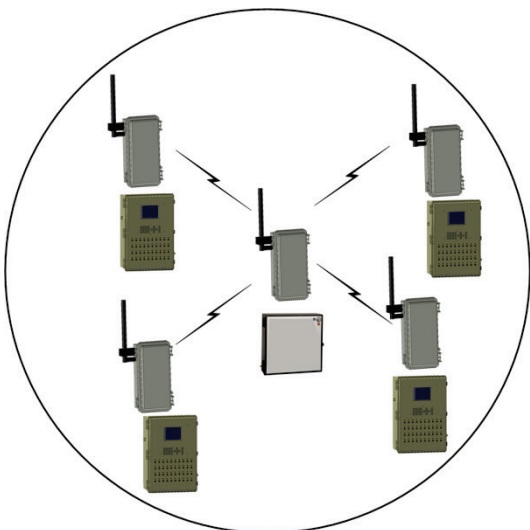

Figure 18: Placing RLINK ONEs Using an Omni-Directional Antenna

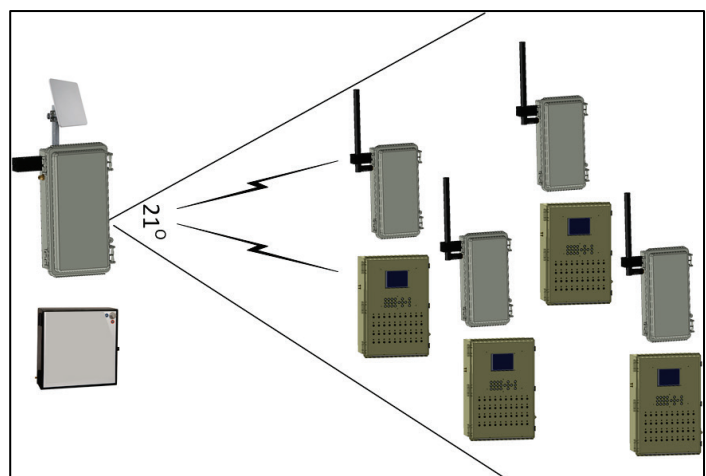

Figure 19: Placing the RLINK ONEs Using a Uni-directional Antenna

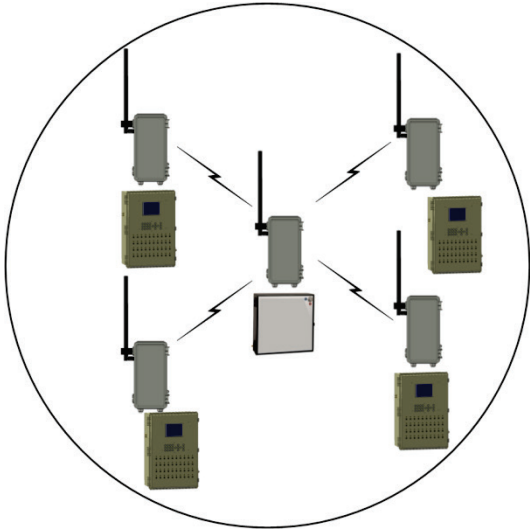

Figure 20: Using an 8 dBi Antenna

6.2.3 Testing the Signal Strength

RLINK One's Loopback mode enables users to test the signal strength even before the units are wired to the communication devices and controllers. By using this function, users can test different placement to find the optimal location for the base and remote units.

➡ This procedure requires two people, one at the base unit and the second at the remote unit.

To test the signal strength:

1. Install an RLINK One in the base location.
2. Apply power to the base RLINK One.
3. Set the base RLINK One's mode to **Base** (refer to Defining the Mode, page 31).
4. Press **Config** for five seconds (Figure 21). This generates a test signal. The green LED begins to blink.

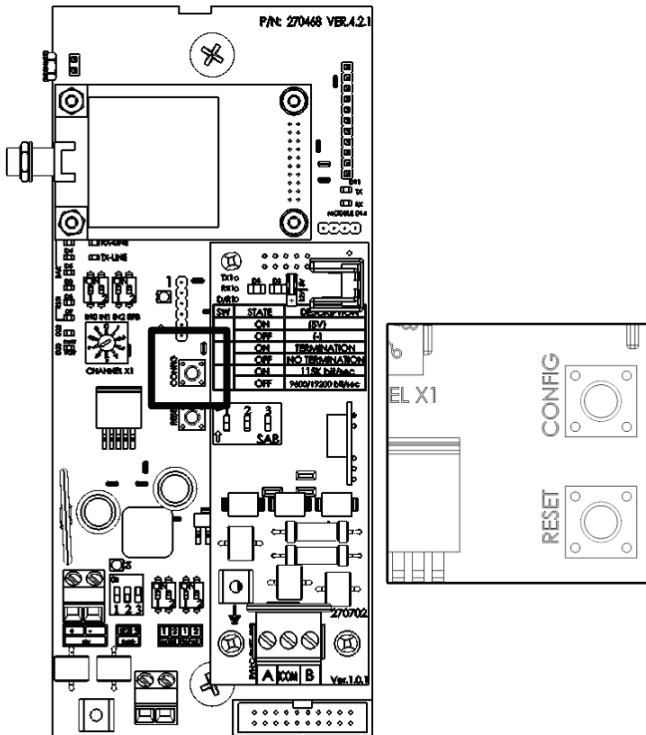

Figure 21: Configuration Button

5. Place the remote RLINK One in the test location.
6. Apply power to the remote RLINK One.
7. Set the remote RLINK One's mode to **Loopback** (refer to Defining the Mode).
8. In the remote unit, view the RSSI LEDs. The unit should be receiving a signal from the base unit. At least two LEDs should light up continually for one minute (refer to Table 1).

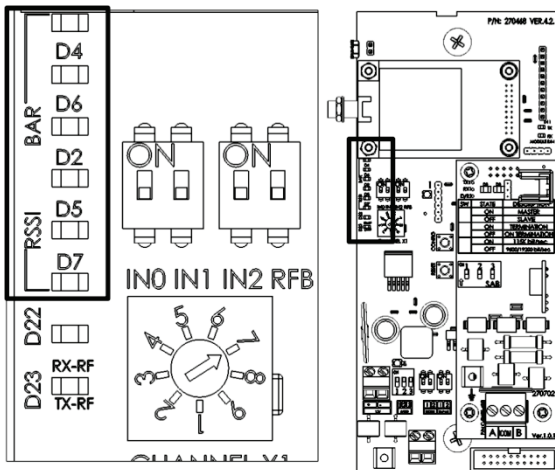

Figure 22: Signal Strength LEDs

CAUTION Run the test for one minute. This step is required to verify the signal stability and consistence. This short test allows for the possibly of the RSSI LEDs lighting up because of random reflections and/or weather conditions.

- If two LEDs light up, the RLINK One signal strength is satisfactory.
- If one LED lights up, signal strength does not meet the minimum requirements.
- Review the factors mentioned in RF Transmission Quality.

- Change the Remote unit's position, the Base unit's position, or both units' position and test again.
 - Install an RLINK One unit defined as a repeater (refer to Defining the Mode, page 31).
9. To stop generating the test signal, disconnect the power to the base unit.

Table 1: LEDs and Signal Strength

No LED	Weak Signal	< 12 dB
1	In Between	> 12 dB
2	Moderate Signal	> 18 dB
3	In Between	> 24 dB
4	Strong Signal	> 30 dB
5	In Between	> 36 dB
6	Very Strong Signal	> 42 dB

6.2.3.1 Freeze Protection

RLINK One includes automatic reset functions in case there is no incoming RF signal.

- After two minutes, the unit resets itself (all RSSI LEDs blink once).
- After five minutes, the unit reconfigures itself.

6.3 Wiring the RLINK ONE

The following sections describe:

- Wiring the office RLINK ONE
- Wiring the field RLINK ONE
- Powering the Unit

6.3.1 Wiring the office RLINK ONE

The following section details how to wire an office RLINK ONE to a communication device.

- Figure 23: Wiring a Farm Guard external box to a RLINK ONE-485
- Figure 24: Wiring a USB RS-485 to an RLINK ONE
- Figure 25: Wiring an Farm Communication Box-485 to a RLINK ONE

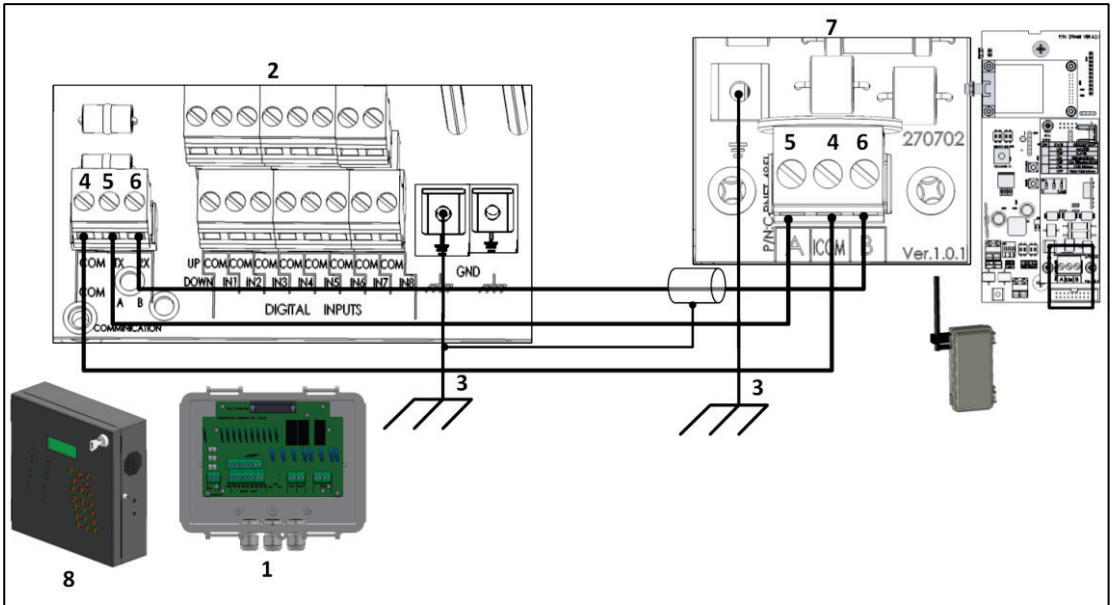

Figure 23: Wiring a Farm Guard external box to a RLINK ONE-485

Figure 23 key			
1	Farm Guard External Box	5	A port
2	Farm Guard External Box ports	6	B port
3	Grounding	7	RLINK One board
	COM port	8	Farm Guard

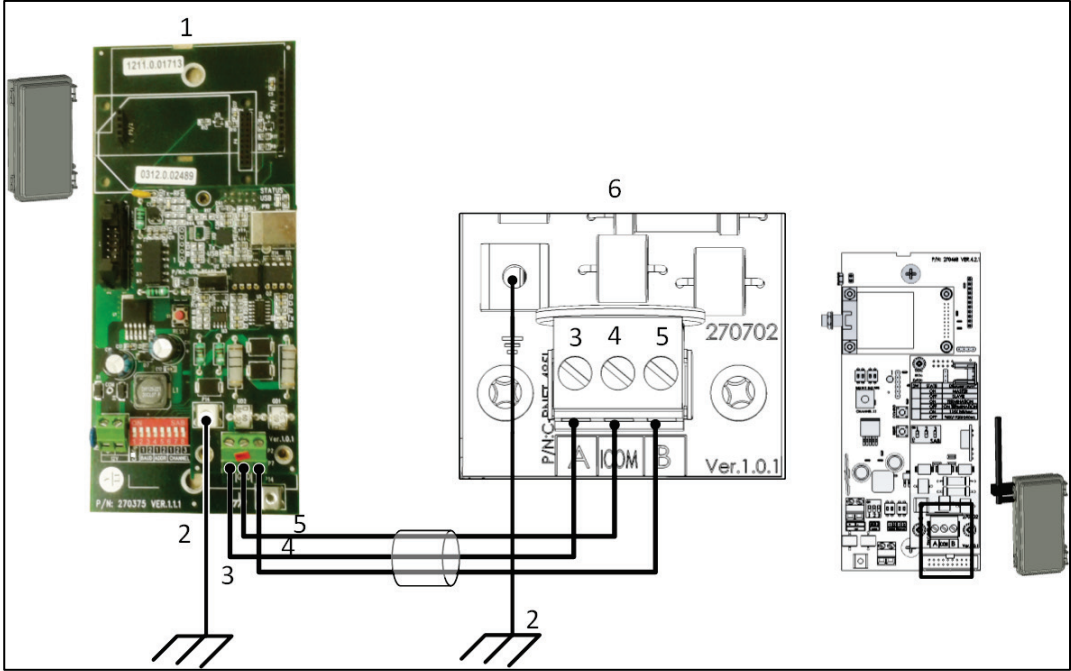

Figure 24: Wiring a USB RS-485 to an RLINK ONE

Figure 24 key

1	A (red wire)	5	USB Driver board
2	Ground cable	6	RLINK ONE board
3	B (black wire)	7	Shield cable
4	Twisted pair cable		

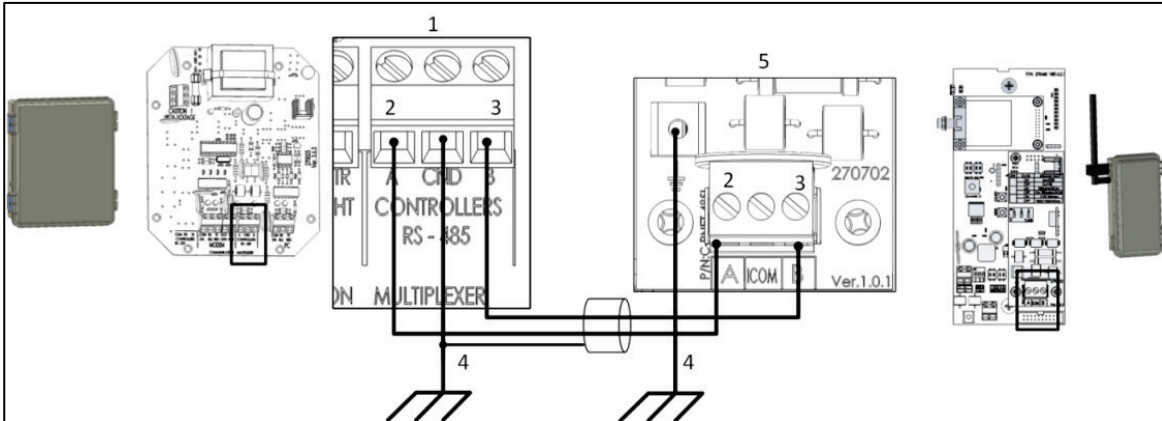

Figure 25: Wiring an Farm Communication Box-485 to a RLINK ONE

Figure 25 key

1	MUX 485 board	4	Grounding
2	A (red wire)	5	RLINK ONE Board
3	B (black wire)		

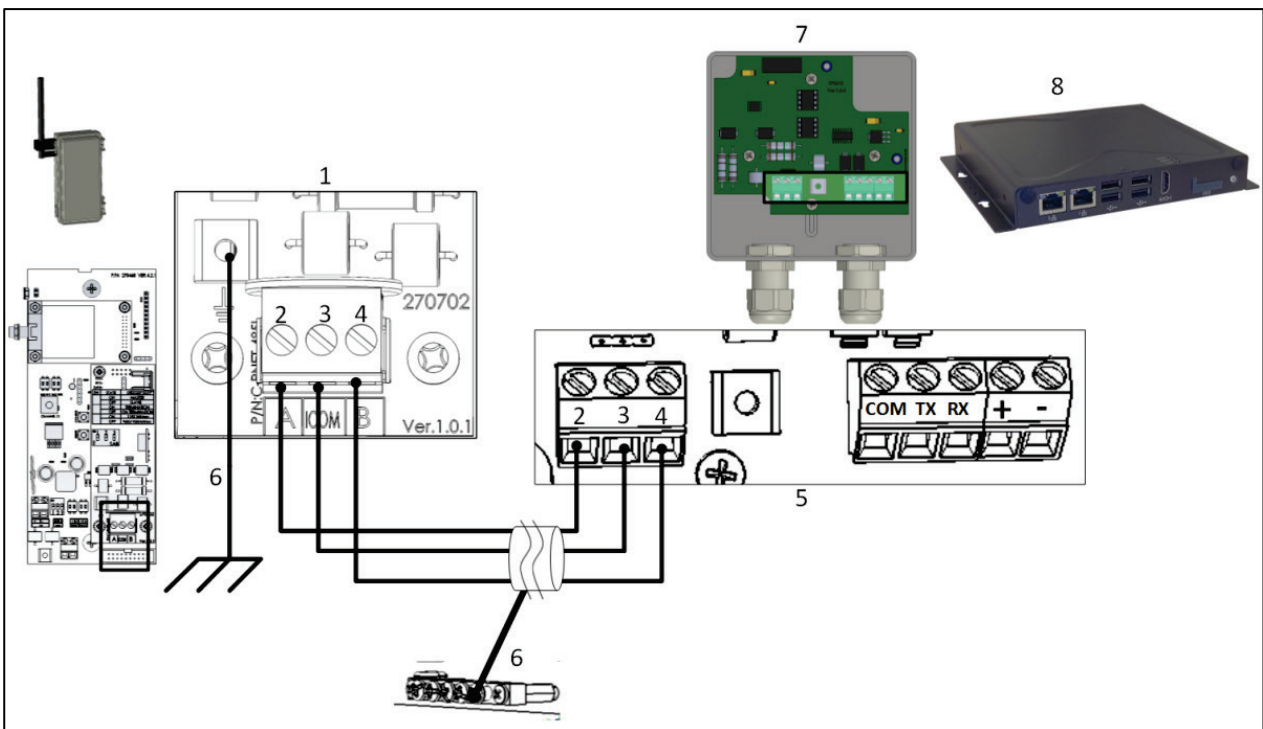

Figure 26: Wiring an Junction Box to an RLINK ONE

Figure 26 key

1	RLINK One board	5	Junction Box board
2	A port	6	Grounding
3	COM	7	Junction Box
4	B port	8	Comm Box

6.3.2 Wiring the field RLINK ONE

The following section details how to wire an RLINK One to a controller (Field RLINK One).

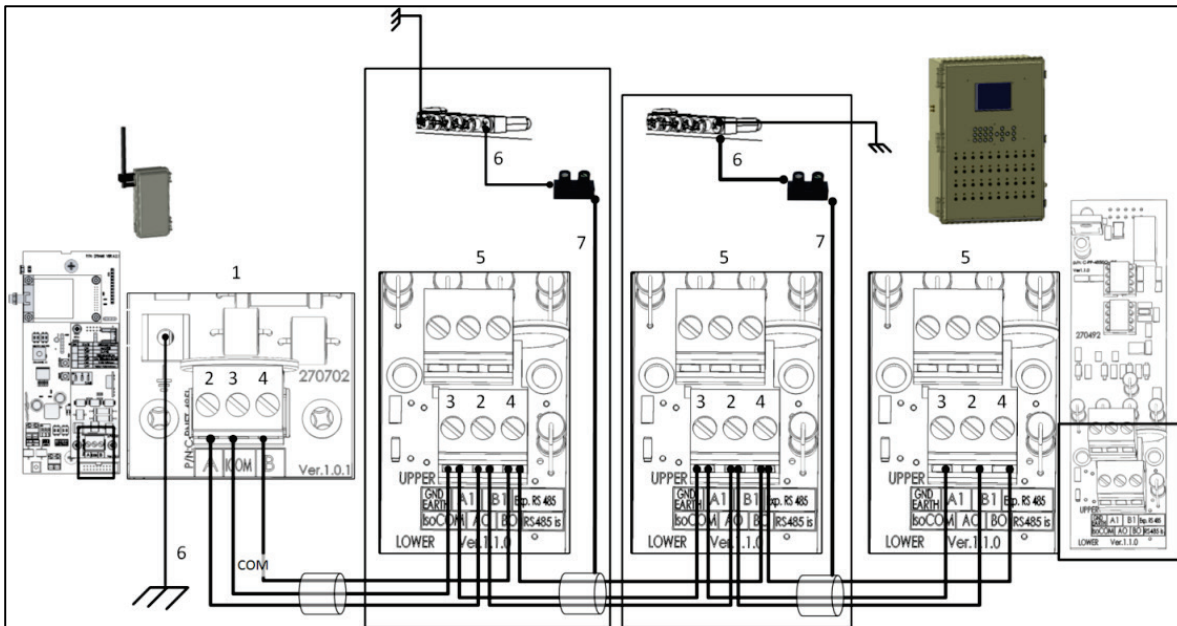

Figure 27: Wiring a RLINK ONE to a RS-485 Communication Card (Isolated COM)

Figure 27 key

1	RLINK One board	5	Controller communication card
2	A port	6	Ground strip
3	COM	7	Cable shield
4	B port	10	

NOTE The RLINK ONE RS-485 Communication Card port labelled GND is actually an isolated common port. Do not attach a grounding wire to this port.

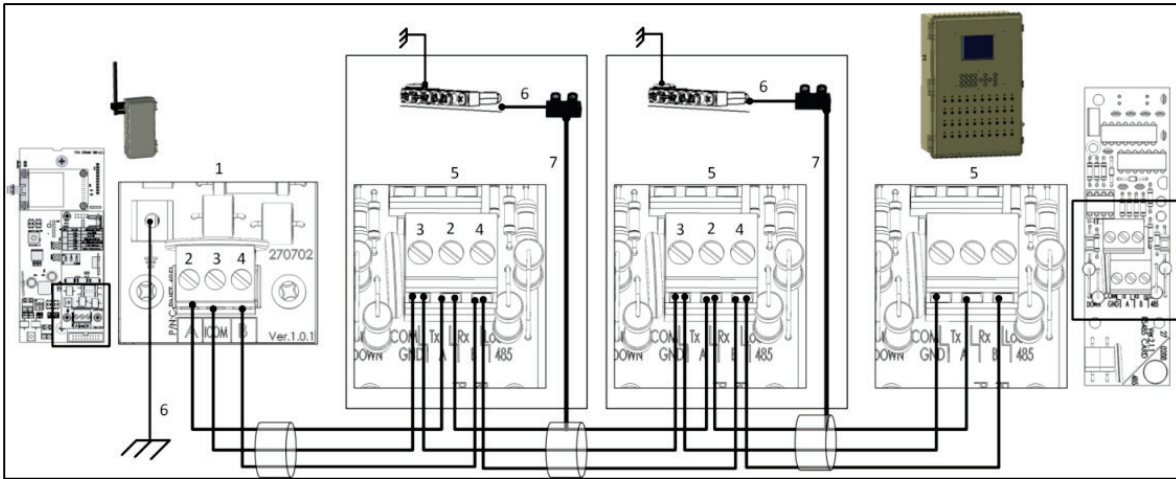

Figure 28: Wiring a RLINK ONE to a RS-485 Communication Card (Non-Isolated COM)

Figure 28 key

1	RLINK One board	5	Controller communication card
2	A port	6	Ground strip
3	COM	7	Cable shield
4	B port		

As an alternative, the RLINK can be grounded via the controller.

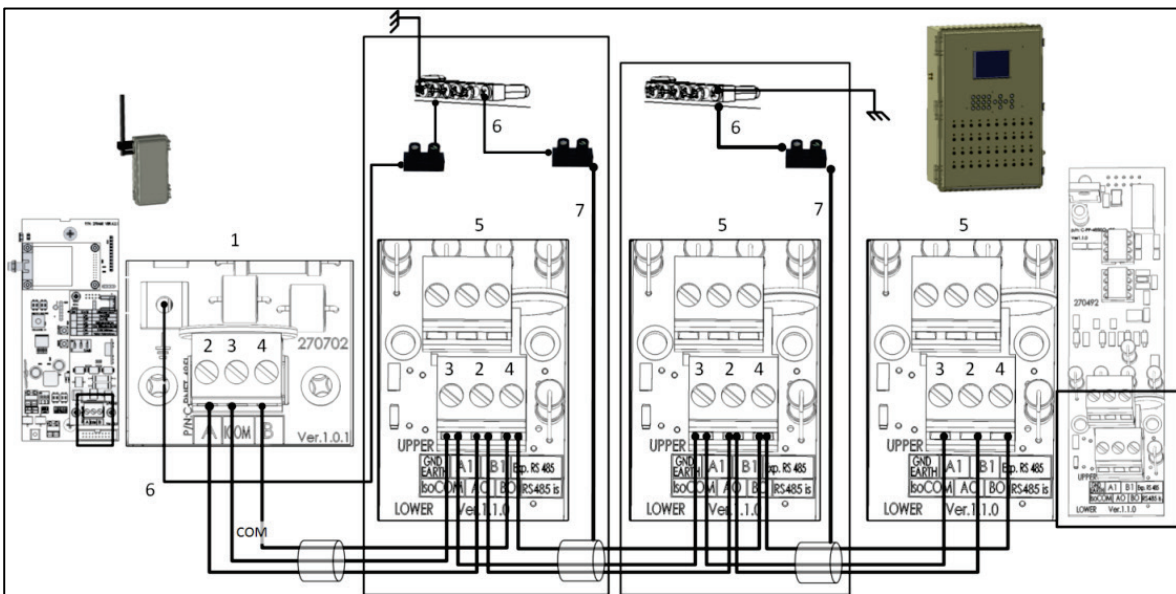

Figure 29: Grounding an RLINK One via the Controller

- Connect the shield cable of each controller to the ground strip on one side only!

Figure 29 key

1	RLINK One board	5	Controller communication card
2	A port	6	Connect the RLINK One ground port to the nearest controller's ground strip.
3	COM	7	Cable shield

Figure 29 key

4 B port

6.3.3 Powering the Unit

- Connect the RLINK ONE to the power source and power supply as shown in Figure 30.

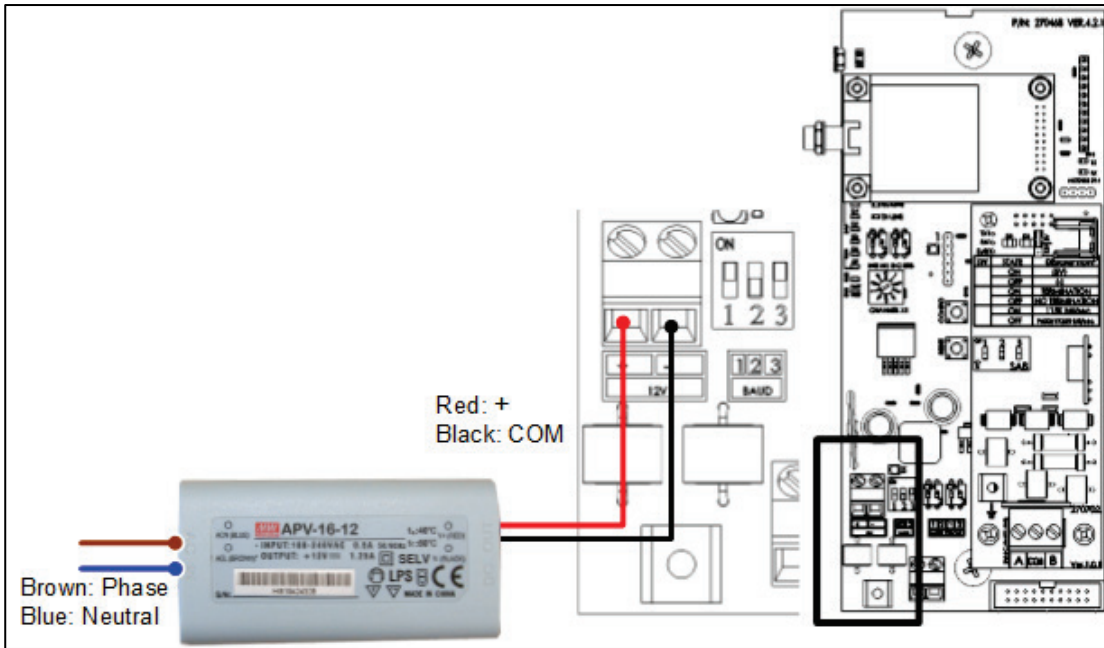
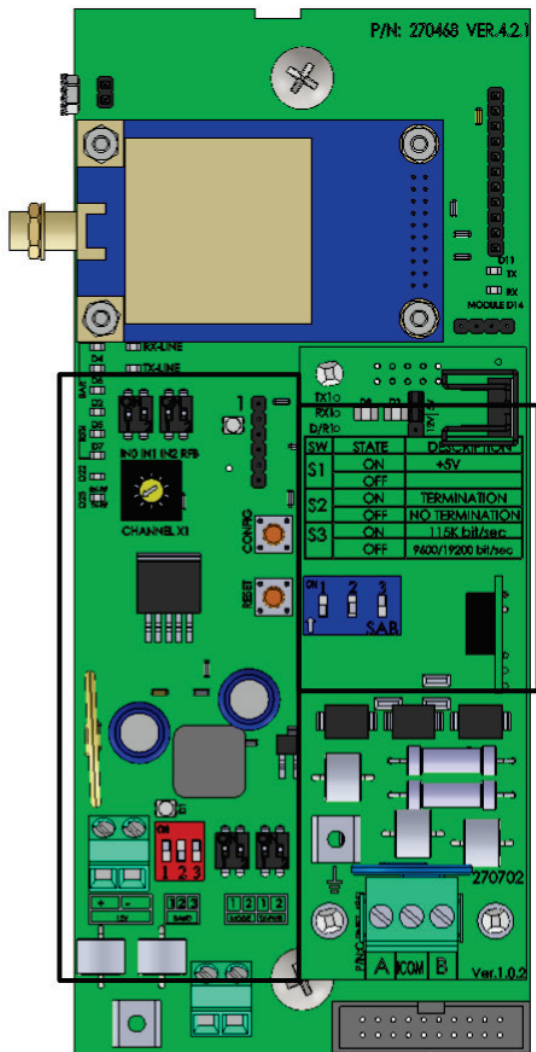

Figure 30: RLINK ONE Power Wiring

7 Configuring the Unit

The following sections describe how to configure each RLINK. Each RLINK One includes a mother board and a communication card.

- The mother board includes dipswitches and a potentiometer used to configure the wireless communication.
- The communication card includes dipswitches used to configure the RS-485 communication.



Board dip switches
And Channel Selector

Communication Card
Dipswitches

Figure 31: RLINK Board and Dipswitches

7.1 Configuring the Wireless Communication

Configuring the wireless communication consists of:

- Defining the Baud Rate
- Defining the Mode
- Defining the Power Level
- Defining the Channel
- Defining the Platinum/Gateway Protocol

NOTE After changing any dipswitches or channels, press the Config button to actualize the change.

7.1.1 Defining the Baud Rate

RLINK One can transmit data at various baud rates. Table 2 summarizes the rate settings. When setting the baud rate, Munters recommends the following:

- Since faster rates and longer transmission distance mean a greater chance of transmission errors, reduce the baud rate as you increase the distance.
- If RLINK One is being used and the connection is to several controllers at different distances, reduce the baud rate until you establish an error-free connection to the RLINK One located at the furthest distance. Use that baud rate for all other RLINK Ones. In any case where there are transmission errors, reduce the baud rate.

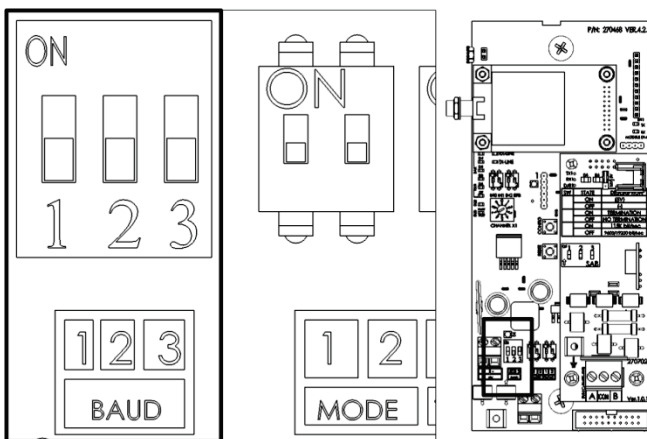

Figure 32: Baud DIP Switches

Table 2: Baud Rate Dipswitch Settings

Baud Rate (bps)	Switch Settings		
	1	2	3
1200	On	On	On
2400	Off	Off	On
4800	Off	On	Off
9600 (default)	Off	Off	Off
19200	Off	On	On
38400	On	Off	Off
115200	On	On	Off

CAUTION Performing a Cold Start on the Farm Guard resets the Farm Guard baud rate to 9600. Therefore, after a Cold Start, reset the Farm Guard's baud rate to match the RLINK ONE's baud rate.

7.1.2 Defining the Mode

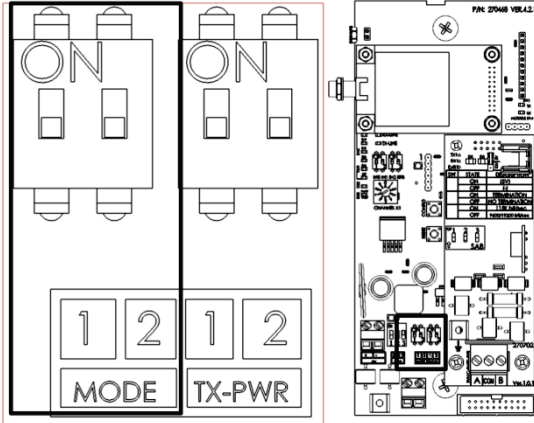

Figure 33: Mode DIP Switches

RLINK One units can work in four different modes, depending on their location and function. Table 3

Table 3: Mode Dipswitch Settings

Mode	Switch Settings	
	Switch 1	Switch 2
Base (unit connected to communication device)	On	Off
Remote (unit connected to controller) (default setting)	Off	Off
Repeater (unit used to boost signal strength)	Off	On
Loopback (unit used to test signal strength during setup)	On	On

To define the mode:

1. Set the dipswitches as required.
2. Press **Config**. The D1 LED blinks (blue LED).
3. If the configuration works, RLINK One corrects the LEDs' colors:
 - Base: Blue
 - Remote: Green
 - Repeater: Pink
 - Loopback: White
 - Configuration failure: Red (press **Config** again for two (2) seconds).

NOTE Refer to *Testing the Signal Strength*, page 21 for details on how to use an RLINK One in Loopback Mode.

7.1.3 Defining the Power Level

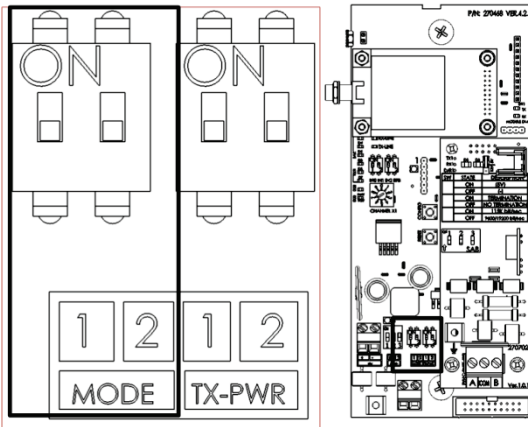

Table 4: Power Level Dipswitches

Power Level	Switch Settings	
	Switch 1	Switch 2
1 W (default setting)	Off	Off
500 mW	On	Off
100 mW	Off	On
10 mW	On	On

To define the power level:

1. Set the dipswitches switches to the required level.
2. Using an RLINK One unit in Loopback mode, test the signal strength (option). Refer to Testing the Signal Strength, page 21 for details.

7.1.4 Defining the Channel

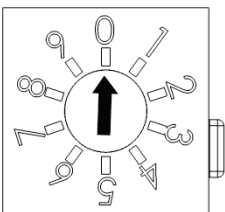

CHANNEL X1

To define the channel:

- Using a screw driver, turn the potentiometer to the required channel setting.
 - RLINK One supports nine channels.
 - Verify that all RLINK One units in a given network have the same channel setting.
 - If a neighboring farm is using RLINK One, ensure that you use a different channel number in your network.
 - If required, expand the number of channels (refer to Expanding the Number of Channels).

7.1.4.1 Expanding the Number of Channels

As an option, for large operations requiring a larger number of channels, RLINK One has an option enabling expanding the number of channels from 10 to 20.

CAUTION Only authorized technicians may expand the number of channels.

To expand the number of channels:

1. Go to the RFB Dipswitch. By default the switch is in the off position.

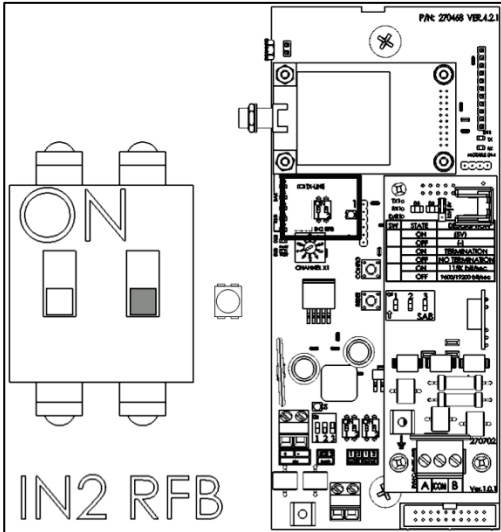

Figure 34: RFB Dipswitch Default Position (Channels 0 - 9)

2. Place the RFB Dipswitch in the on position. The LED turns blue.

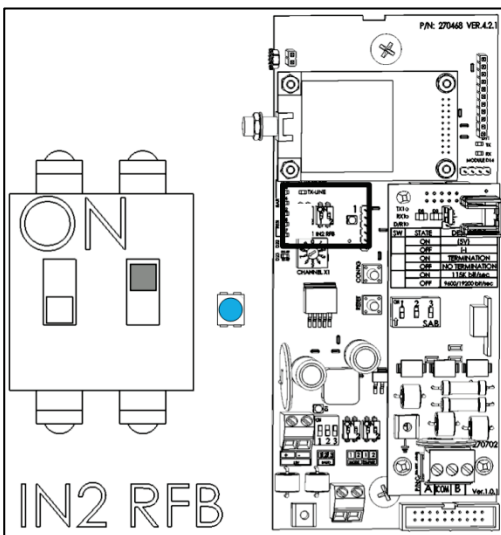

Figure 35: RFB Channel Expansion Position (Channels 10 - 19)

7.1.5 Defining the IN2 Dipswitch

- This dipswitch is for internal use only

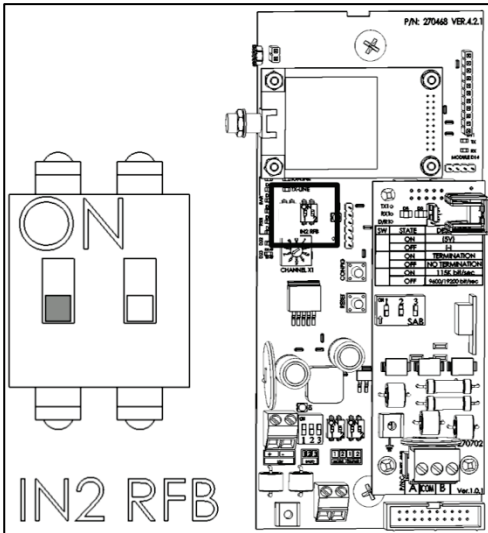

Figure 36: Platinum Protocol

7.2 Configuring the RS-485 Communication

Configuring the RS-485 communication consists of:

- Defining the 5V Status
- Defining the Termination

SW	STATE	DESCRIPTION
S1	ON	+5V
	OFF	
S2	ON	TERMINATION
	OFF	NO TERMINATION
S3	ON	115K bit/sec
	OFF	9600/19200 bit/sec

Figure 37: Communication Board Dipswitches

7.2.1 Introduction to Termination and 5V Setup

The following section provides guidelines on how to set the RNET-485i Card and RLINK One dipswitches.

- Termination
 - Termination is required in each chain, in the beginning and in the end units.
 - When RLINK One is a beginning or end unit, enable termination using the dipswitch.
 - When a controller or the Farm Guard is a beginning or end unit, install an external 120 Ω terminator.

- (5V)
 - Always enable (5V) in the RLINK One unless the RLINK One is wired to a Farm Guard. In the latter situation, Farm Guard provides the 5V to the line, ensuring proper communication.

The illustrations below demonstrate these principles:

- (5V) means RLINK One supplies 5V

Table 5: Termination/(5V) and RLINK One Dipswitch Summary (Example 1)

RLINK One	Mode		IN2 RFB		Power TX-PW	Channel	Baud	RNET-485i Card		
	SW 1	SW 2	SW 1	SW 2				(5V) SW 1	Termination SW2	SW3 (Not in use)
A	Base		X		See note	Same throughout network	Same throughout network	(-)	T	
	On	Off	Off	Off				Off	On	
B	Remote		X			Same throughout network	Same throughout network	5V	T	
	Off	Off	Off	Off				On	On	

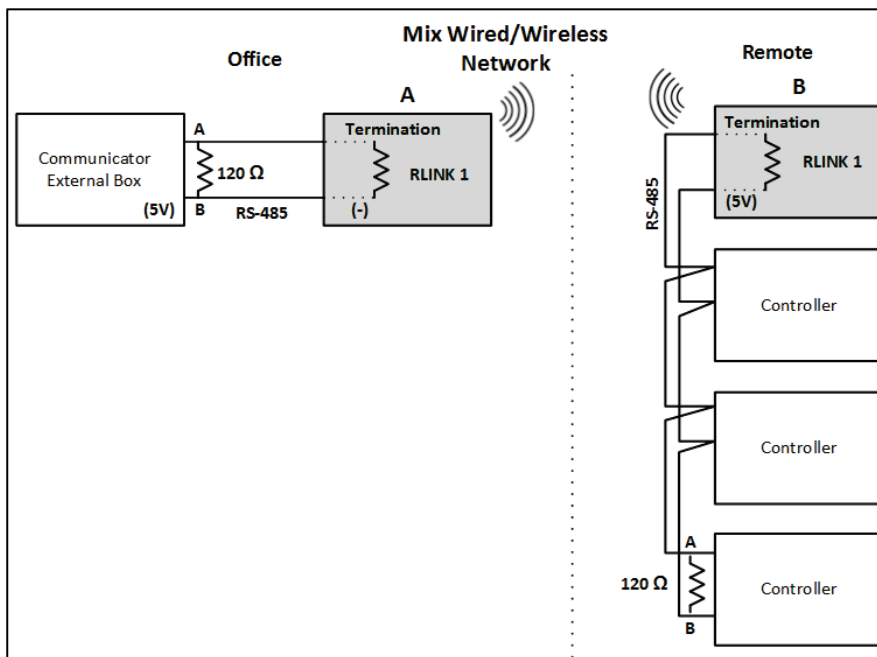

Figure 38: Termination/5V Example 1

Table 6: Termination/(5V) and RLINK One Dipswitch Summary (Example 2)

RLINK One	Mode		IN2 RFB		Power	Channel	Baud	RNET-485i Card		
	SW 1	SW 2	SW 1	SW 2				(5V) SW 1	Termination SW2	SW3 (Not in use)
A	Base		X		See note	Same throughout network	Same throughout network	(-)	T	
	On	Off	Off	Off				Off	On	
B	Remote		X			Same throughout network	Same throughout network	5V	T	
	Off	Off	Off	Off				On	On	

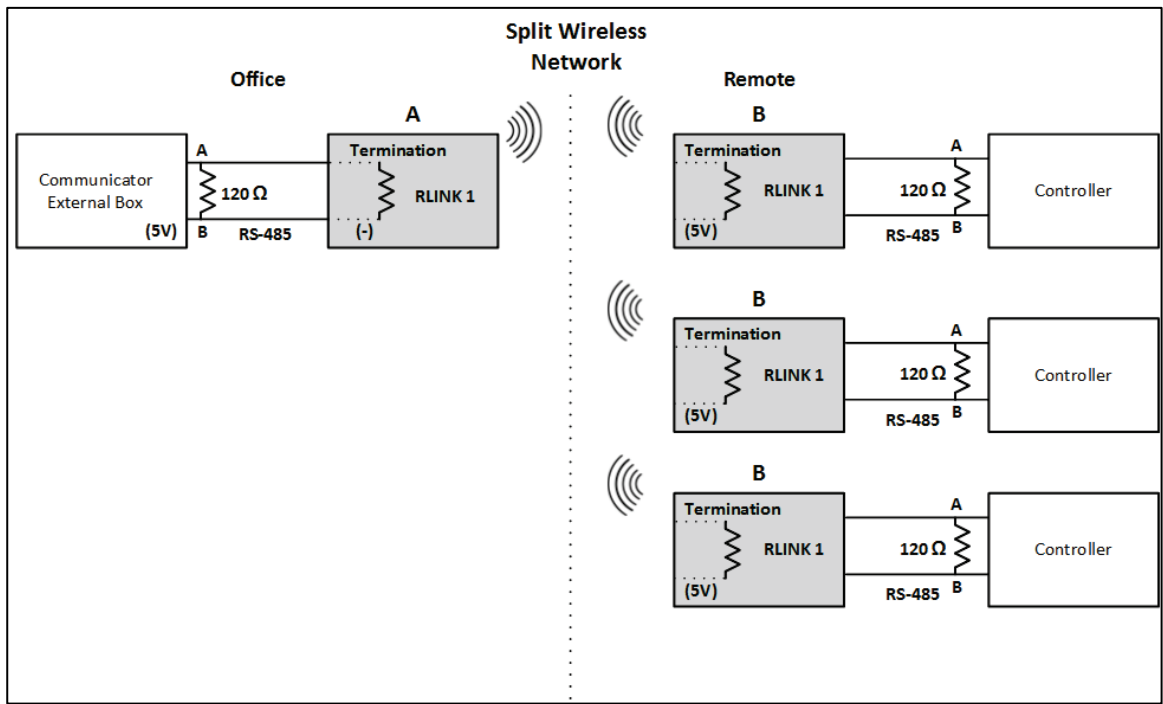

Figure 39: Termination/(5V) Example 2

Table 7: Termination/(5V) and RLINK One Dipswitch Summary (Example 3)

RLINK 1	Mode		IN2 RFB		Power TX-PW	Channel	Baud	RNET-485i Card		
	SW 1	SW 2	SW 1	SW 2				(5V) SW 1	Termination SW2	SW3 (Not in use)
C	Base		X		See note	Same throughout network	Same throughout network	(-)	T	
	On	Off	Off	Off				Off	Off	
D	Repeater		X			Same throughout network	Same throughout network	X	X	
	Off	On	Off	Off				Off	Off	
E	Remote		X			Same throughout network	Same throughout network	(5V)	T	
	Off	Off	Off	Off				On	Off	

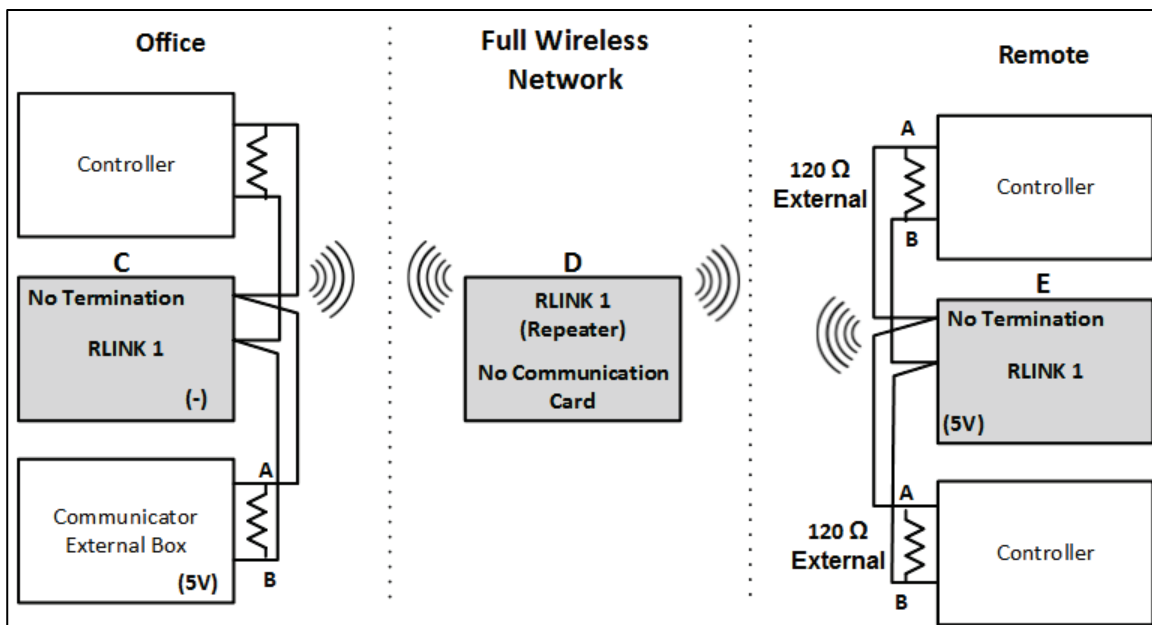

Figure 40: Termination/(5V) Example 3

NOTE By default, power levels are set to 1W (China: 500 mW). Users requiring other levels should refer to Defining the Power Level, page 32.

7.2.2 Defining the 5V Status

- **When connected to a Farm Guard:** Set the RLINK One to (-) (default setting).

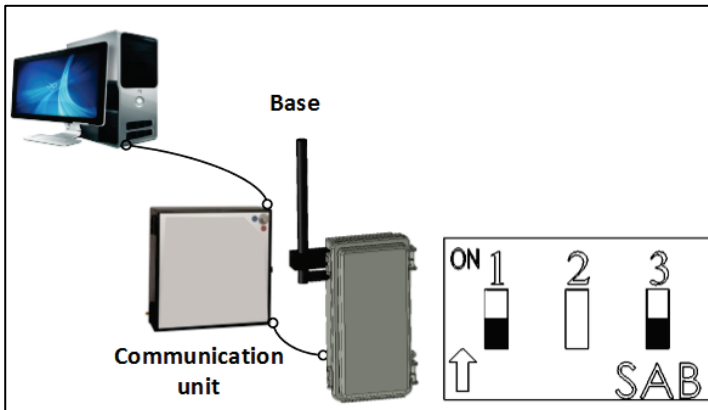

Figure 41: Farm Guard - RLINK One 5V Dipswitches

- **When connected to a controller:** Set the RLINK One to (5V).

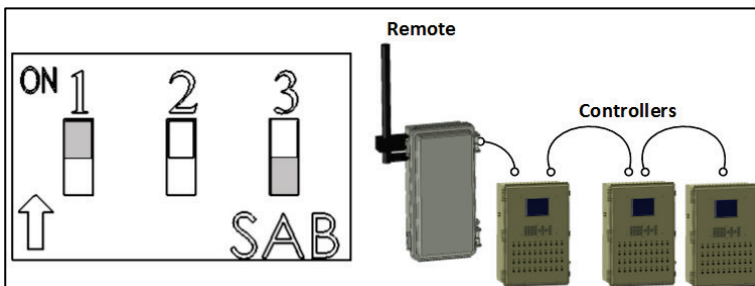

Figure 42: Controller - RLINK One 5V Dipswitches

NOTE Figure 42 does not show the termination dipswitch setting. Refer to *Defining the Termination* for information on this function setting.

- **Repeater/Loopback:** Leave the dipswitches in the default position.

7.2.3 Defining the Termination

In long distance networks, termination is required to prevent a signal from being reflected back from the end, causing interference. The terminator is placed at the end of a transmission line or daisy chain bus to minimize signal reflections.

RLINK One units contain built-in 120 ohm terminators. Termination activation depends on the RLINK One's position:

- **RLINK One connected to Farm Guard/Gateway:** RLINK One termination is off (default position).
- **Remote units:** Activating a Remote RLINK One's termination is dependent on the unit's location in a chain.
 - When the RLINK One is at the end of the transmission line, set Termination to ON.

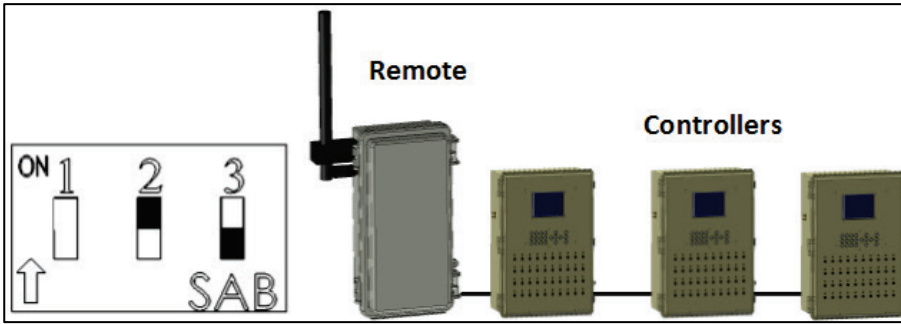

Figure 43: Termination Enabled

- When the RLINK One is in the middle of the transmission line, set Termination to OFF.

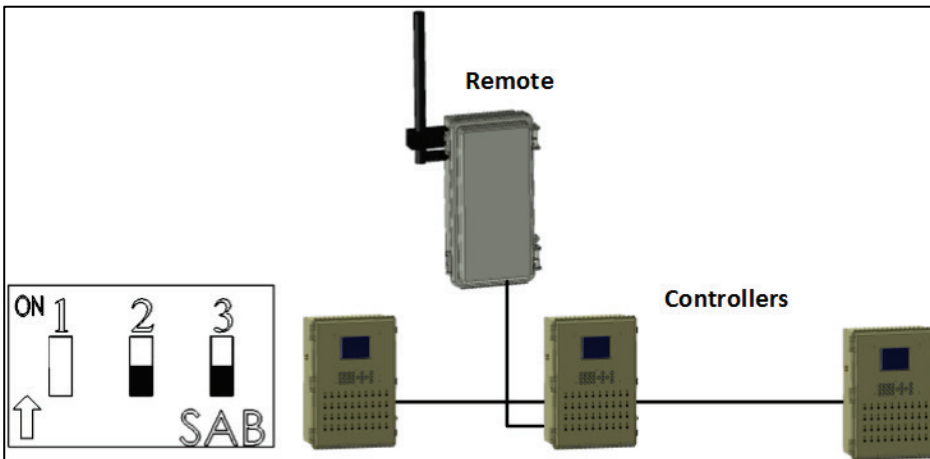

Figure 44: Termination Disabled

7.2.4 Number of Controllers

The maximum number of controllers and cable length in a network is directly dependent on the baud rate between the RLINK and controllers (set in the controllers). Refer to the following table when determining the number of possible controllers in a network.

Table 8: Cable Length

Speed	Cable length	Number of Controllers
1200	2000 m	32 controllers
2400	1000 m	32 controllers
2400	1500 m	10 controllers
4800	500 m	32 controllers
9600	300 m	10 controllers
19200	300 m	10 controllers
38400	300 m	10 controllers
115200	100 m	10 controllers

8 Technical data

RLINK ONE

Power Requirements	12 VDC \pm 10% (stabilized), 1 Amp (maximum)
Transmission Method	Spread spectrum, frequency hopping
Data Rate	User selectable, 9600 MHz default
Receiver Sensitivity	-110 dBm
Frequency	902 - 928 / 915 -929 MHz
Ambient (Operating) Temperature	-20° to +50° C (-4° to +122° F)

Communication Cable Specifications

<ul style="list-style-type: none">• 4 Wires 2 twisted pair• Shielded• 22 AWG• 120 ohm impedance	
--	--

9 Appendix A: Troubleshooting

The RLINK One's board includes LEDs that light up for activity notification. Use these LEDs as a diagnostic tool when performance issues arise.

- **RLINK One to Farm Guard or Controllers LEDs (on communication card)**

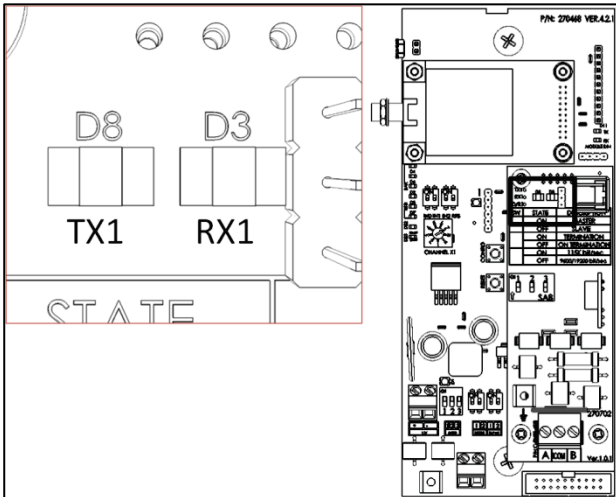

Figure 45: D8 D3 LEDs

If the **D8 D3** LEDs do not blink, check the wired connections to the communication unit or the controller.

- **RLINK One to RLINK One LEDs**

There are two sets of LEDs that describe the wireless communication signal quality.

- Signal strength LEDs: At least two RSSI LEDs (labeled **D2 – D7** RSSI bar) should be lit during transmission. If less than two LEDs are lit, review RF transmission quality, page 15.

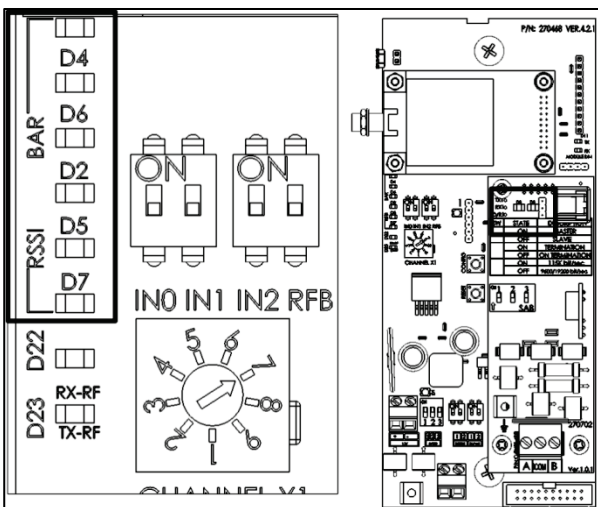

Figure 46: Signal Strength LEDs

- RLINK ONE data transmission:
 - RX-RF LED: RLINK One is receiving data from another RLINK One.
 - TX RF LED: RLINK One is transmitting data to another RLINK One.

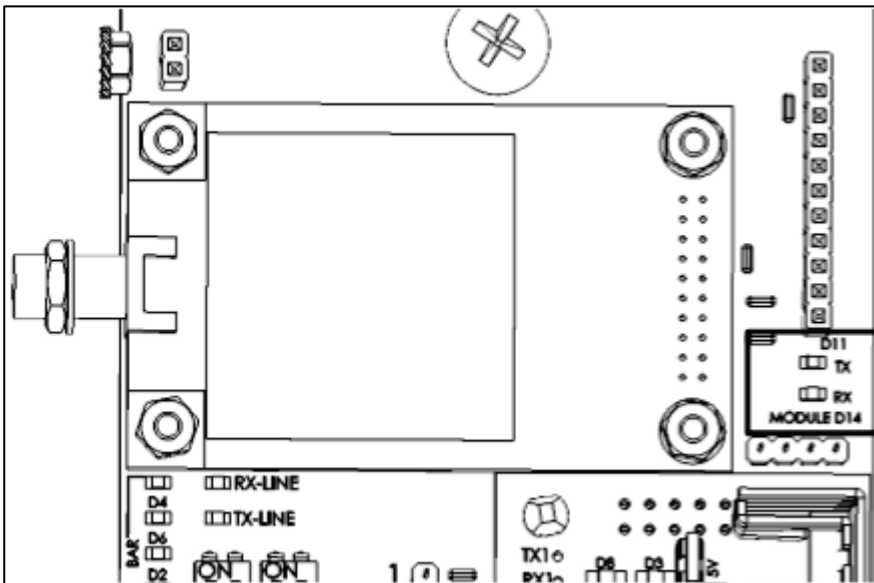

Figure 47: Data Transmission

- CPU - Modem Communication
 - If the D1 LED does not blink, press **Reset**.
 - Reconfigure the mode dipswitch (refer to Defining the Mode, page 31).

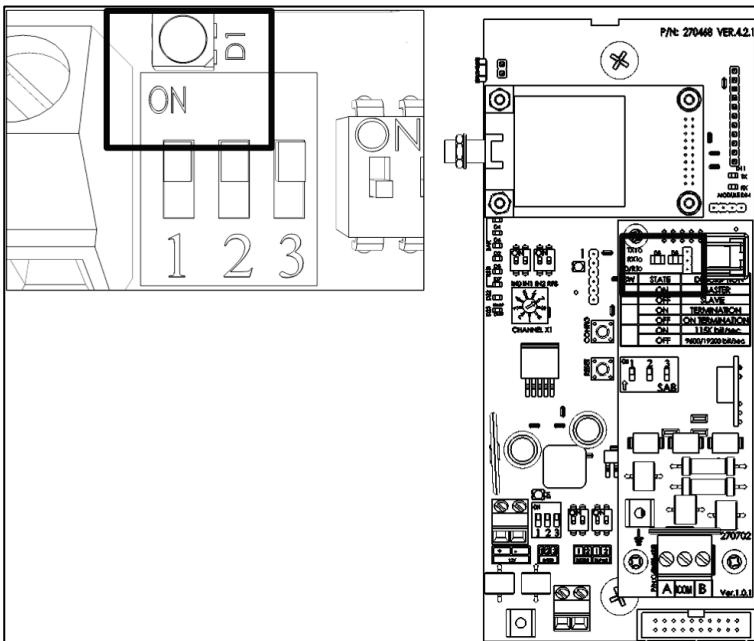

Figure 48: D1 LEDs

10 Warranty

Warranty and technical assistance

Munters products are designed and built to provide reliable and satisfactory performance but cannot be guaranteed free of faults; although they are reliable products they can develop unforeseeable defects and the user must take this into account and arrange adequate emergency or alarm systems if failure to operate could cause damage to the articles for which the Munters plant was required: if this is not done, the user is fully responsible for the damage which they could suffer.

Munters extends this limited warranty to the first purchaser and guarantees its products to be free from defects originating in manufacture or materials for one year from the date of delivery, provided that suitable transport, storage, installation and maintenance terms are complied with. The warranty does not apply if the products have been repaired without express authorisation from Munters, or repaired in such a way that, in Munters' judgement, their performance and reliability have been impaired, or incorrectly installed, or subjected to improper use. The user accepts total responsibility for incorrect use of the products.

The warranty on products from outside suppliers fitted to RLINK ONE, (for example RLINK ONE's antennas, cables, power supplies, etc.) is limited to the conditions stated by the supplier: all claims must be made in writing within eight days of the discovery of the defect and within 12 months of the delivery of the defective product. Munters has thirty days from the date of receipt in which to take action, and has the right to examine the product at the customer's premises or at its own plant (carriage cost to be borne by the customer).

Munters at its sole discretion has the option of replacing or repairing, free of charge, products which it considers defective, and will arrange for their despatch back to the customer carriage paid. In the case of faulty parts of small commercial value which are widely available (such as bolts, etc.) for urgent despatch, where the cost of carriage would exceed the value of the parts, Munters may authorise the customer exclusively to purchase the replacement parts locally; Munters will reimburse the value of the product at its cost price.

Munters will not be liable for costs incurred in demounting the defective part, or the time required to travel to site and the associated travel costs. No agent, employee or dealer is authorised to give any further guarantees or to accept any other liability on Munters' behalf in connection with other Munters products, except in writing with the signature of one of the Company's Managers.

WARNING: *In the interests of improving the quality of its products and services, Munters reserves the right at any time and without prior notice to alter the specifications in this manual.*

The liability of the manufacturer Munters ceases in the event of:

- dismantling the safety devices;
- use of unauthorised materials;

- inadequate maintenance;
- use of non-original spare parts and accessories.

Barring specific contractual terms, the following are directly at the user's expense:

- preparing installation sites;
- providing an electricity supply (including the protective equipotential bonding (PE) conductor, in accordance with CEI EN 60204-1, paragraph 8.2), for correctly connecting the equipment to the mains electricity supply;
- providing ancillary services appropriate to the requirements of the plant on the basis of the information supplied with regard to installation;
- tools and consumables required for fitting and installation;
- lubricants necessary for commissioning and maintenance.

It is mandatory to purchase and use only original spare parts or those recommended by the manufacturer. Dismantling and assembly must be performed by qualified technicians and according to the manufacturer's instructions.

The use of non-original spare parts or incorrect assembly exonerates the manufacturer from all liability.

Requests for technical assistance and spare parts can be made directly to the nearest Munters office. A full list of contact details can be found on the back page of this manual.

Munters Israel

18 HaSivim Street
Petach-Tikva 49517, Israel
Telephone: +972-3-920-6200
Fax: +972-3-924-9834
support@munters.co.il



www.munters.com

Australia Munters Pty Limited, Phone +61 2 8843 1594, **Brazil** Munters Brasil Industria e Comercio Ltda, Phone +55 41 3317 5050, **Canada** Munters Corporation Lansing, Phone +1 517 676 7070, **China** Munters Air Treatment Equipment (Beijing) Co. Ltd, Phone +86 10 80 481 121, **Denmark** Munters A/S, Phone +45 9862 3311, **India** Munters India, Phone +91 20 3052 2520, **Indonesia** Munters, Phone +62 818 739 235, **Israel** Munters Israel Phone +972-3-920-6200, **Italy** Munters Italy S.p.A., Chiusavecchia, Phone +39 0183 52 11, **Japan** Munters K.K., Phone +81 3 5970 0021, **Korea** Munters Korea Co. Ltd., Phone +82 2 761 8701, **Mexico** Munters Mexico, Phone +52 818 262 54 00, **Singapore** Munters Pte Ltd., Phone +65 744 6828, **South Africa and Sub-Sahara Countries** Munters (Pty) Ltd., Phone +27 11 997 2000, **Spain** Munters Spain S.A., Phone +34 91 640 09 02, **Sweden** Munters AB, Phone +46 8 626 63 00, **Thailand** Munters Co. Ltd., Phone +66 2 642 2670, **Turkey** Munters Form Endüstri Sistemleri A.Ş, Phone +90 322 231 1338, **USA** Munters Corporation Lansing, Phone +1 517 676 7070, **Vietnam** Munters Vietnam, Phone +84 8 3825 6838, **Export & Other countries** Munters Italy S.p.A., Chiusavecchia Phone +39 0183 52 11