

HLR-1000E:

TECHNICAL SPECIFICATIONS



10/7/15 v 1.8

Table of Contents

Introduction..... 3
 The Problem the HLR Addresses 3
HLR Overview: The System, the Module and the Sorbents 4
 The HLR System 4
 The HLR 1000E Module 4
 The Sorbents..... 5
Functionality and Benefits..... 5
 Functionality..... 5
 Benefits..... 6
Component Location and Description..... 8
Air Flow Capacity 9
Weight and Dimensions 10
Electrical Panel 10
 a. Power Requirements 10
 b. Communications..... 11
 c. Fans & Heaters 11
 d. Built-in Connections - Required..... 11
 e. Built-in Connections – Additional Available Connections 12
 f. Sensors 12
Description of HLR 1000E Modes 12
Monitoring and Reporting..... 13
Annual Maintenance - Cartridge Set Replacement..... 13
Installation Specifications..... 13
ASHRAE Standard 62.1 Compliance 16
Support..... 16

Introduction

The York HVAC Load Reduction (HLR™) module is a 'smart scrubber' that replaces costly ventilation control methods with a practical, proven, energy-saving approach using the latest advances in materials and chemical engineering as well as digital technology. By treating the indoor air, York's innovative HLR solution minimizes the amount of outdoor air required to maintain indoor air quality (IAQ) and thereby reduces the load on the HVAC system and its energy consumption.

The HLR 1000E offers the benefits of double-digit energy savings while maintaining indoor air quality (IAQ) and is an 'all season' system, automatically managing HVAC cooling and heating loads. The HLR 1000E is a closed-loop design with each module having an integrated heating, mechanical, electrical, and communication system.

The Problem the HLR Addresses

Widely adopted approaches to maintaining indoor air quality are outdated and inefficient. Rather than the costly process of continually taking in outdoor air to maintain indoor air quality, the HLR module directly treats the indoor air by scrubbing out contaminants with its patented sorbent technology. This minimizes the load on the HVAC system, therefore significantly reducing its energy consumption.

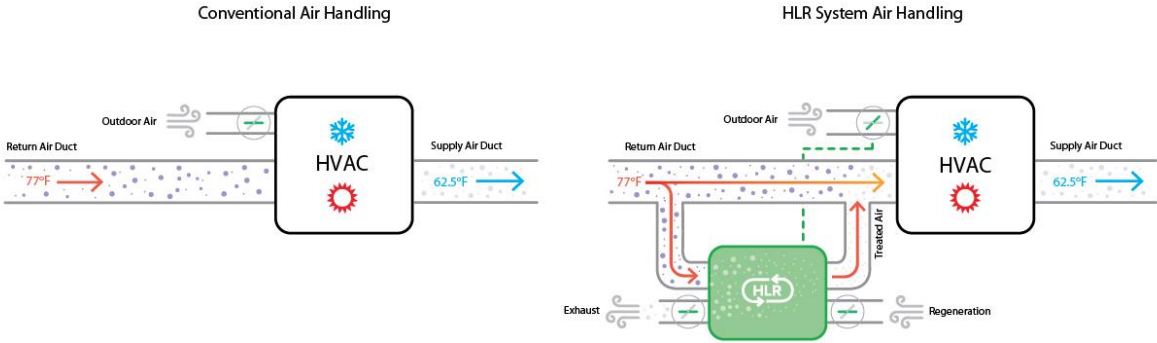

HLR Overview: The System, the Module and the Sorbents

The HLR System

The system is a group of networked HLR 1000E Modules installed in the mechanical rooms or indoor air plenums in a building. The HLR 1000E incorporates state-of-the-art wireless technology for peer-to-peer and cloud connectivity enabling enhanced real-time monitoring, reporting and system results validation.



The HLR 1000E Module



A fully self-contained mechanical design with easy side-by-side retrofit to existing HVAC infrastructure.

- All season module; heating and cooling
- Designed to maximize energy efficiency & savings
- Operates using standard single-phase power
- Light-weight, easy to install

The Sorbents

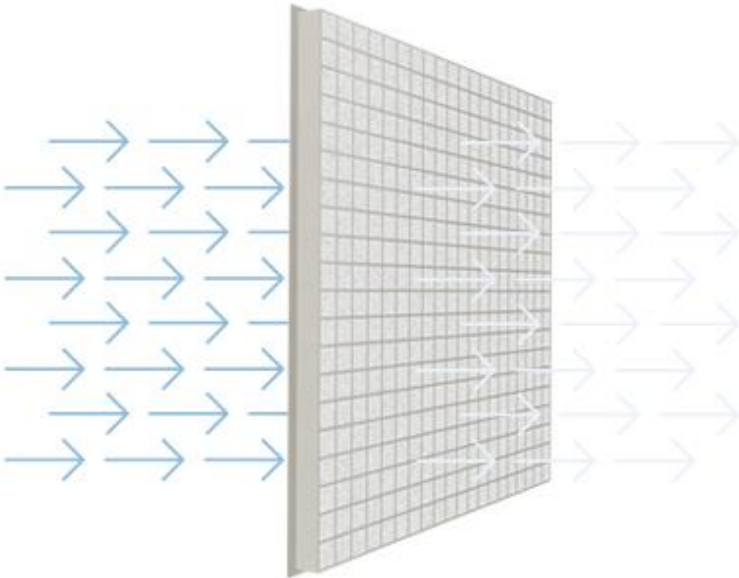

Two processes sequentially operate to scrub the indoor air and purge the captured contaminants to maintain indoor air quality. Advanced technology, including materials and chemical science breakthroughs, enables patented sorbents to capture CO₂, formaldehyde and VOCs during the sorption process. Air travels through the sorbents housed in the cartridge set for the air to be cleaned. Sensors monitor the sorbents for saturation, and then the regeneration process is automatically launched to purge the sorbents of the captured contaminants, exhausting them outside the building.

Functionality and Benefits

Functionality

The HLR Module actively and automatically manages HVAC heating and cooling load and indoor air quality. Its dramatic results are enabled by the following four integrated capabilities:

Indoor Air Treatment

- Proprietary cartridges contain patented sorbents that eliminate carbon dioxide, formaldehyde and volatile organic compounds (VOCs).

- Embedded sensors continually monitor indoor air quality, sorbent performance and system operating conditions to ensure optimal IAQ management.

Automated Regeneration

- Several times a day, cartridges are ‘regenerated’, causing the sorbents to release the captured contaminants to the outside of the building.
- Regeneration is scheduled, managed and timed for automatic performance and minimal energy use.

Outside Air Management

- Electromechanical control of the HVAC system’s outside air damper minimizes the amount of outside air ventilation based on energy and air quality considerations.
- Automatic fail-safe setting in case of fire emergency, power outage or malfunction.

Monitoring and Reporting

- Built-in electronics and software, including networking for online internet connectivity, engineered to control, record and report all aspects of the HLR system operation.
- Sophisticated proprietary algorithms designed to maximize energy savings.

Benefits

The HLR 1000E Module delivers significant energy savings while maintaining indoor air quality. The benefits of the HLR solution include:

Load Reduction and Energy Savings

- Over 40% reduction in peak power load
- 20% average energy cost savings (heating and/or cooling)

Indoor Air Quality

- The only commercial solution that effectively addresses CO₂, formaldehyde and VOCs
- Dramatically reduced intake of outdoor pollutants

Real-time Monitoring, Reporting and Validation

- 24/7 online access to performance metrics including air quality and real-time, validated energy savings
- Remote control of the system at your fingertips by computer or smart phone

Scalability and Flexibility

- Easy side-by-side retrofit with existing HVAC infrastructure
- A network of multiple HLR modules offers a scalable solution for any building
- Simple, turn-key installation; vertical or horizontal installation; fits through standard doorway; lightweight
- Requires minimal labor for installation

Reliability

- Minimal routine maintenance; cartridge set replacement only once a year
- Robust design delivers 20+ year operating life

Compliance and Sustainability

- Meets ASHRAE Standard 62.1 for ventilation and indoor air quality
- Qualifies for U.S. Green Business Council LEED credits

Component Location and Description

The HLR 1000E works in all climates. Each HLR 1000E Module is a self-contained cabinet pre-assembled with the following components:

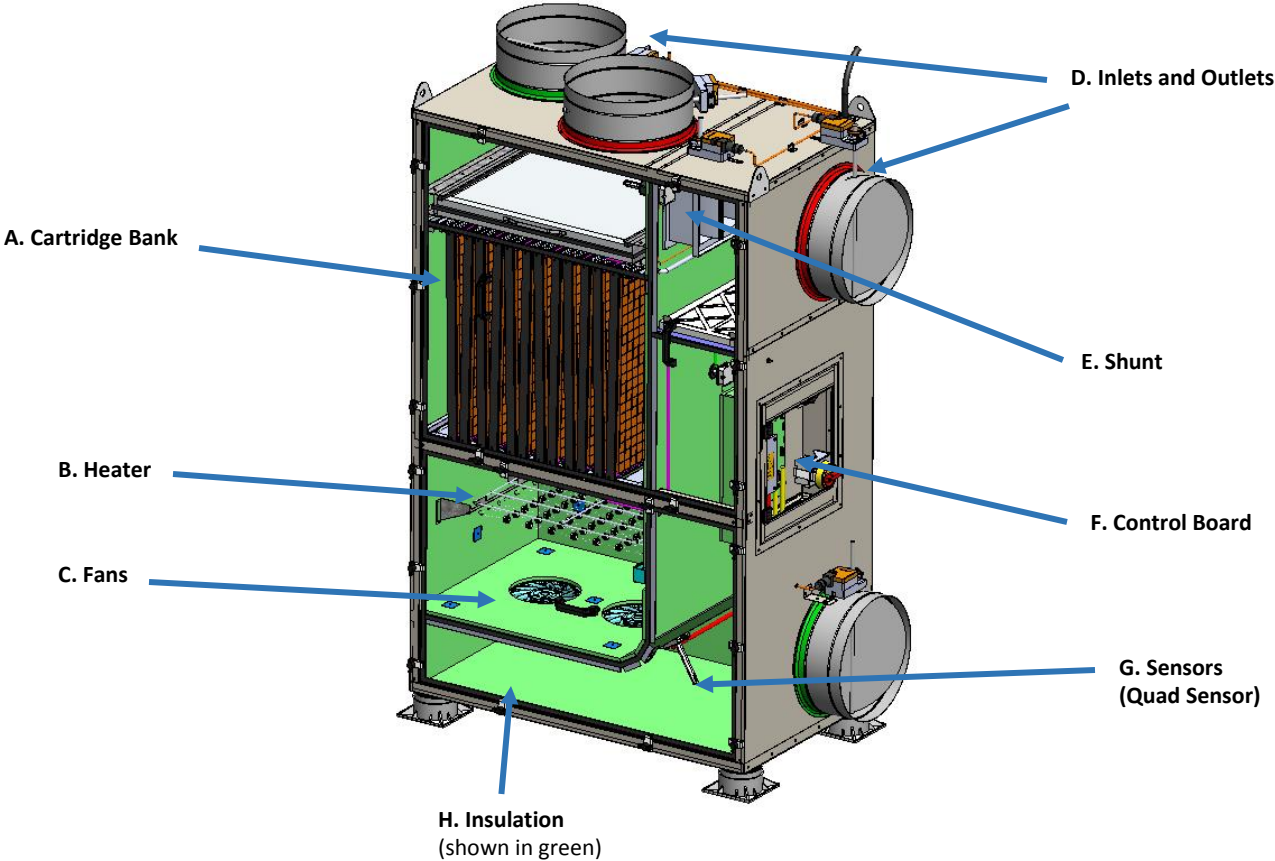

- A. **Cartridge Bank** – The cartridge bank houses a set of twelve cartridges which contain the sorbents that collect select contaminants (CO₂, formaldehyde and VOCs) during the sorption (cleansing) cycle and then release the captured contaminants during the regeneration (outdoor purge) cycle. Cartridges are constructed in polypropylene further reducing total weight of the unit.

- B. **Heater** – The integrated heater raises the internal temperature of the HLR 1000E to initiate the process of releasing the captured contaminants. During this time all external dampers are closed, and air is re-circulated inside the HLR 1000E to accelerate the release process.

- C. **Fans** – Integrated DC brushless fans control the airflow through the HLR 1000E during the sorption and regeneration cycles. The controller has speed control and active feedback from the fans verifying correct operation.
- D. **Inlets and Outlets** – The HLR 1000E Module has 2 circular inlets and two circular outlets controlled by dampers. The inlets that route the air during sorption are highlighted in green. The outlets that route the air during the purge portion of the regeneration cycle are highlighted in red.
- E. The internal **Shunt** that is used during the heating portion of the regeneration cycle is controlled by a damper that is only open when all other dampers are closed.
- F. **Control Board** – The electronic enclosure contains the HLR 1000E power supply and the controller board. The power supply converts the incoming AC power to the necessary voltages to operate all aspects of the unit. The controller contains the systems software, all controls/relays/sensor interfaces, as well as all wireless and wired communication modules.
- G. **Sensors** – The HLR 1000E unit contains three integrated internal multi-sensor modules used to measure temperature, humidity, CO₂ concentration, formaldehyde and VOC levels during the sorption and regeneration cycles. The HLR 1000E has two additional temperature and humidity sensors for monitoring the incoming outside air and the supply air from the air handling unit (AHU) to the conditioned space.
- H. **Insulation** – The inside walls of the HLR 1000E unit are covered in heat-reflective insulation material for improved efficiency of the unit and soundproofing.

Air Flow Capacity

The HLR 1000E is designed to handle up to 1000 CFM (cubic feet per minute) of air in a slipstream configuration drawn from the return air path of the HVAC system. The number of modules required for any given building is determined by multiple considerations including contaminant sources, floor space, occupancy, exhaust systems and building pressurization. A typical guideline for office buildings is to have one HLR 1000E for approximately every 20,000 square feet of floor space, however only a qualified HLR installation professional can determine the correct number and configuration of units required.

Weight and Dimensions

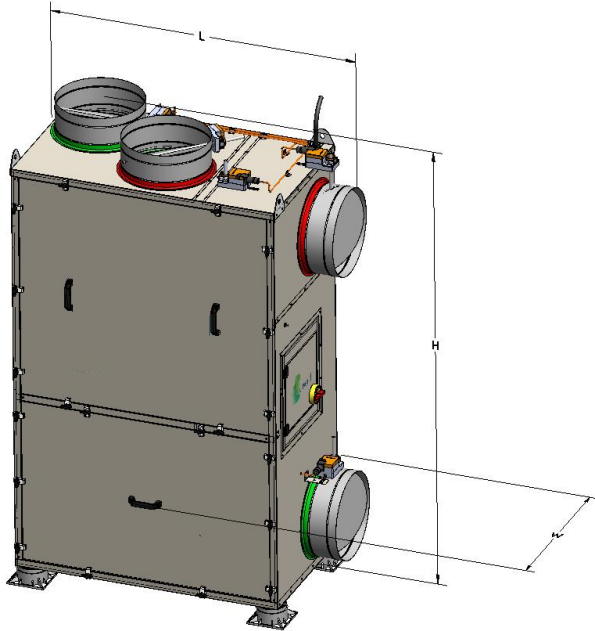

Weight	lbs (kg)
Unit Cabinet	200 (90.7)
Unit with Cartridge Set	400 (181.4)

Dimensions	Unit	Unit with Dampers & Handles
Length	50" (128 cm)	43" (110 cm)
Width	27" (68 cm)	25" (63 cm)
Height	74" (187 cm)	68" (172 cm)

Electrical Panel

a. Power Requirements

The HLR is designed to work with single phase AC power and can accommodate a range of line voltages and frequencies.

Supply	Main	208 – 277VAC/50-60Hz/16A

b. Communications

Each HLR 1000E module includes wireless communication capabilities for ongoing monitoring and reporting of indoor air quality, sorbent performance and system operating conditions. This wireless link is a state-of-the art solution with a long-range reach and ultralow power consumption. The HLR 1000E is able to communicate with all BACnet™ based building management systems.

Communications	Cellular Link	2.5G/3G
	Wireless Link	915 MHz
	BACnet over MSTP	ISO-RS485

c. Fans & Heaters

Powerful, light-weight digitally controlled fans combined with an integrated heater deliver an effective and efficient variable air flow solution.

		Voltage/Power
Air Flow Components	Fan(s)	24VDC/72W (each)
	Heater with PID control	277VAC/6.5kW

d. Built-in Connections - Required

The HLR 1000E interfaces to the AHU (air handling unit) using the required built-in connections listed below. The minimum number of connections in order to operate the HLR 1000E with an AHU are as follows:

1. **Outside Air Damper Actuator** – The HLR 1000E must take control of the Outside Air Damper actuator. This is the key factor that enables the energy savings and load management when using the HLR 1000E.
2. **Outside Air Damper Reading** – The HLR 1000E requires reading the position signal from the OA damper to ensure that the HLR 1000E is setting the damper to the correct position.
3. **Fire Signal** – The fire signal is commonly generated from the fire panel or building automation system in the event of a fire in the building and is used to put the outside air damper and the HLR 1000E and other air handling devices in a mode

that will inhibit smoke/fire from spreading throughout the building through the air ducts.

4. Air Handler Mode – The HLR 1000E operates in conjunction with the AHU.

Connections	OA Damper Control	Output from HLR 1000E: 2-10 VDC
	OA Damper Position Monitoring	Output from HLR 1000E: 2-10 VDC
	Fire Signal Dry Contact Input	Input to HLR 1000E
	AHU Mode Input	Input to HLR 1000E

e. Built-in Connections – Additional Available Connections

Connections	AHU Fan Speed Input	Input to HLR 1000E
	BAS* Open OA Damper Input	Input to HLR 1000E
	BAS Close OA Damper Input	Input to HLR 1000E
	Energy Meter D Input	Input to HLR 1000E
	Available 24 V Relay Output	Output from HLR 1000E 24V/1A
	Available Dry Contact Output	Output from HLR 1000E 1A (max)
	Available Dry Contact Input	Input to HLR 1000E

*BAS - Building Automation System

f. Sensors

	Sensor Function	Location	Measurement*
Multi Sensor	Measures incoming air	HLR Interior	T,RH, IAQ
TRH Sensor - AHU	These sensors measure energy use	SA Duct	T,RH
		OA Duct	T,RH
Pressure Sensor	Measures pressure	HLR Interior	P
Sorbent Temp	Measures temperature during regeneration	HLR Interior	T

*Legend: T (temperature); RH (relative humidity); IAQ (Air Quality); P (pressure)

Description of HLR 1000E Modes

- Sorption Mode – The HLR 1000E forces air to pass through the sorbents, capturing CO₂, formaldehyde and VOCs, and returns the cleansed air back into the airstream.
- Regeneration Mode – The HLR 1000E is disconnected from the normal airstream, purging the sorbents with heated air and exhausting contaminants outside the building.

- Standby Mode – When not in an active mode, the HLR 1000E does not carry air flow, but does continue to monitor its air quality sensors.

Monitoring and Reporting

Each HLR 1000E Module has built-in electronics and software to record and report all aspects of the HLR system operation. A custom SCADA (supervisory control and data acquisition) interface allows users to view real-time and historical data to monitor IAQ and energy savings results. Authorized users have a login with defined permission levels providing access to a website where results can be monitored. The data is uploaded via a wireless link.

Annual Maintenance - Cartridge Set Replacement

The HLR 1000E module is designed to require minimal on-site routine maintenance. Annual cartridge set replacement is the only required standard maintenance. This can be performed by any certified technician. With ongoing maintenance, the HLR 1000E modules are designed for a long operating life of 20+ years.

Cartridge storage

HLR cartridge sets should be stored indoors away from direct sunlight in -10 °C to +35 °C (14°F to 95°F). Cartridges should be kept in their plastic wrap to protect them from moisture or damage prior to installation.

Recycling of cartridges

When cartridges are replaced, the used cartridges should be placed in the packaging from the replacement cartridges, sealed, and shipped back using the return mailing label provided in the cartridge packaging.

Installation Specifications

The HLR 1000E is designed for simple, turn-key installation.

- Simple Installation - the HLR 1000E is designed for simple installation with physical dimensions enabling each unit to fit through a standard doorway; its light weight provides for easy transportation and positioning. Three requirements:

- 1. Electrical power
 - 2. A wireless data connection is built-in; for a wired connection, cable must be hooked up during installation.
 - 3. Air duct connections. The round control dampers ensure quick and cost-effective installation to ducts without needing transitions.
- The HLR 1000E can be installed by one person in approximately 30 minutes.
 - Indoor installation - durable finish, sturdy construction and reflective insulation make the HLR 1000E compatible with indoor installations. The modules can be located anywhere in the general vicinity of the Air Handling Unit (AHU), in the building’s mechanical rooms.
 - Vertical or horizontal installation for easy side-by-side retrofit to existing HVAC infrastructure
 - Two options for installation:
 - Case I: Ducted Return
 - Case II: Plenum Return

Case I: Ducted Return

The HLR 1000E module is designed for a slipstream topology, and the air flow through the module is, by design, a small fraction of the total circulation.

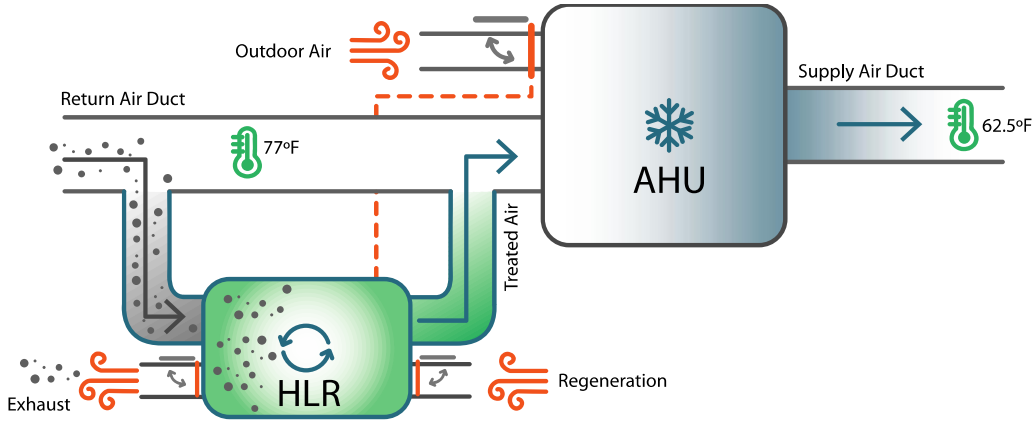

The slipstream topology, as shown in the schematic above, is a unique feature of the HLR solution. Among other things, it allows the system to go ‘off-line’ for regeneration or for maintenance without any disruption to the building ventilation systems. The inlet and the outlet of the HLR 1000E module are independently ducted to the indoor air ducts. The flow

rate through the HLR 1000E is a small fraction of the total circulation and varies by indoor contaminant load.

Case II: Plenum Return

In plenum-based return air systems, the HLR 1000E module can be positioned inside the plenum with no ductwork for the indoor air. The module pulls in air from the plenum and ejects treated air back into the plenum. However, in this type of installation, the purge air inlets and outlets must be ducted to an appropriate outside air source and exhaust, respectively.

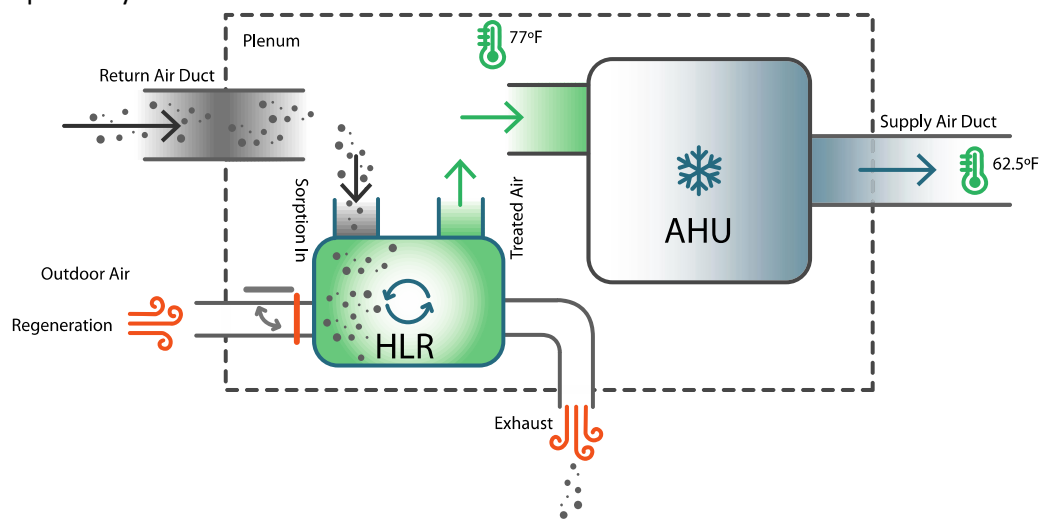

Below are some high level installation steps for the HLR 1000E. Consult the installation manual and any relevant National and Local codes as required.

1. Bring the HLR 1000E and cartridges to the installation area. The HLR 1000E and cartridge set are shipped in separate containers and should be transported in these separate containers until the cartridges are ready to be installed.
2. Unpack the HLR 1000E and place in the orientation required for the particular installation. Note: the HLR 1000E operates in either a horizontal or vertical configuration.
3. Remove the upper door exposing the cartridge compartment.
4. Install the cartridges per the installation instructions.
5. Install the upper door closing the cartridge compartment.
6. Connect the four (4) required ducts. All ducts are standard round 14-inch style.

7. Connect the two (2) remote sensors to the HLR1000 E unit per the installation instructions.
8. Connect AC power to the HLR 1000E unit per the power requirement instructions.
9. Turn on the HLR 1000E unit using the front panel power switch.
10. Complete the commissioning and testing procedure per the installation instructions.

ASHRAE Standard 62.1 Compliance

The York HLR 1000E guarantees *ASHRAE Standard 62.1: Ventilation for Acceptable Indoor Air Quality* IAQP compliance levels. The HLR scrubbing system is formally in compliance with ASHRAE 62.1 Standard requirement and fits within the IAQP. The ASHRAE official document issued on January 25, 2015 publicly states and affirms that the use of air cleaning as a method to remove contaminants of concern is an acceptable method to decrease outdoor airflow.

[Interpretation 62.1-2013-4-January 25, 2015](#)

Support

For additional support required during installation or operation, please contact York Technical Support.

ALL PRODUCTS, PRODUCT SPECIFICATIONS AND DATA ARE SUBJECT TO CHANGE WITHOUT NOTICE TO IMPROVE RELIABILITY, FUNCTION, DESIGN OR OTHERWISE