

# ELTROPLAN-REVCON

Elektrotechnische Anlagen GmbH

## Operating instructions



Power feedback unit REVCON<sup>®</sup> RLD E0

Power range 8 ... 431kW  
Voltage range 400V, 500V

<b>1</b>	<b>Preface and general information .....</b>	<b>3</b>
1.1	<b>About these Operating Instructions .....</b>	<b>3</b>
1.1.1	<b>Terminology used .....</b>	<b>3</b>
1.1.2	<b>Ordering code .....</b>	<b>4</b>
1.2	<b>Scope of delivery.....</b>	<b>4</b>
1.3	<b>Legal regulations.....</b>	<b>5</b>
1.4	<b>EC-Directives / Declaration of conformity .....</b>	<b>6</b>
1.4.1	<b>EC-low voltage directive .....</b>	<b>6</b>
1.4.2	<b>EC-directive Electromagnetic compatibility .....</b>	<b>7</b>
1.4.3	<b>EC-directive Machinery .....</b>	<b>8</b>
<b>2</b>	<b>Safety information .....</b>	<b>9</b>
2.1	<b>General safety information.....</b>	<b>10</b>
2.2	<b>Safety-responsible persons.....</b>	<b>14</b>
2.3	<b>Layout of the safety information .....</b>	<b>15</b>
2.4	<b>Residual hazards .....</b>	<b>15</b>
2.5	<b>General instructions.....</b>	<b>16</b>
<b>3</b>	<b>Technical data.....</b>	<b>27</b>
3.1	<b>Characteristics .....</b>	<b>27</b>
3.2	<b>General data / application conditions .....</b>	<b>28</b>
3.3	<b>Rated data .....</b>	<b>29</b>
3.3.1	<b>Power feedback unit REVCON RLD E0 .....</b>	<b>29</b>
3.4	<b>Fuses and wire cross sections .....</b>	<b>32</b>
3.5	<b>RFI-filter REVCON RLD E0.....</b>	<b>35</b>
3.6	<b>Harmonic filter module RHF-RA module .....</b>	<b>37</b>
<b>4</b>	<b>Installation .....</b>	<b>39</b>
4.1	<b>Mechanical installation .....</b>	<b>39</b>
4.1.1	<b>Important hints.....</b>	<b>39</b>
4.2	<b>Figures and facts .....</b>	<b>40</b>
4.2.1	<b>Dimensions, weight and power loss.....</b>	<b>40</b>
4.2.2	<b>Maximum cross section, screws and tightening torque.....</b>	<b>42</b>
4.2.3	<b>Dimensions .....</b>	<b>44</b>
4.2.4	<b>Dimensions RFI-filter .....</b>	<b>51</b>
4.2.5	<b>Dimensions RHF-RA-filter .....</b>	<b>54</b>
4.3	<b>Electrical installation .....</b>	<b>59</b>

---

## Contents

---

4.3.1	Operator's safety .....	59
4.3.2	Protection of the power feedback unit .....	59
4.3.3	Mains types / Mains characteristics .....	60
4.3.4	Specifications of the used wires.....	60
4.4	Connection .....	61
4.4.1	Power connection .....	61
4.4.1.1	Wiring schematic REVCON RLD E0 .....	63
4.4.1.2	Wiring schematic REVCON RLD E0 with RHF-RA .....	65
4.4.1.3	Wiring schematic REVCON RLD E0 and FC with RHF-RA .....	67
4.4.2	Fan supply .....	69
4.4.3	Dimensions RFI-filter .....	69
4.4.4	Control functions .....	69
4.5	Application example .....	73
4.6	Installation of a power feedback unit in a CE-typical drive system .....	74
4.6.1	Installation .....	76
4.6.2	Connection of a RFI-filter .....	77
4.6.3	Design of an EMC-conformal cabinet .....	78
4.6.4	Remarks .....	79
4.6.5	Installation of control wires.....	80
5	Commissioning.....	81
5.1	First powering up .....	81
6	Configuration.....	82
7	Troubleshooting and fault elimination .....	85
7.1	LED-messages .....	86
8	Service.....	88
9	Options.....	89
10	REVCON® product overview .....	92
10.1	Contact.....	93

## 1 Preface and general information

### 1.1 About these Operating Instructions

- These Operating Instructions help you to work properly on and with the power feedback units REVCON® RLD. They contain safety information which must be observed and information which are necessary for an undisturbed operation of the units together with the exploitation of all the advantages of the system.
- All persons who work on and with the power feedback units REVCON® RLD must have the Operation instructions available and observe all relevant notes and instruction.
- The Operating Instructions must always be in a complete and perfectly readable state.

#### 1.1.1 Terminology used

##### **Power feedback unit**

For „Power feedback unit „REVCON® RLD“ in the following the term „Power feedback unit“ is used.

##### **Controller**

For the frequency inverter which is used together with the power feedback unit in the following the term „Controller“ is used.

##### **Drive system**

For a drive system with power feedback units, controller and other components of the drive system in the following the term „Drive system“ is used.

## Preface and general information

### 1.1.2 Ordering code

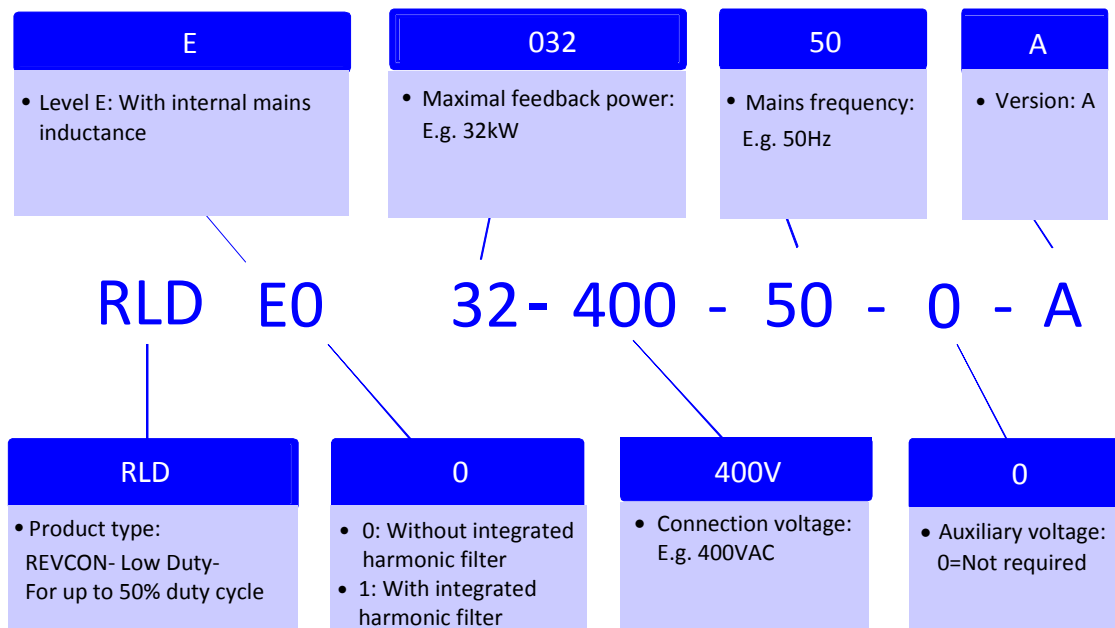

### 1.2 Scope of delivery

- 1 Power feedback unit REVCON® RLD
- 1 Operating instructions
- After receipt of the delivery verify immediately, if the scope of supply correspond to the shipping documents. We make no warranty for later complained defects

#### Claim

- Visible transport damages in transit immediately at the deliverer.
- Visible deficiencies/incompleteness immediately to ELTROPLAN-REVCON.

**Preface and general information**

**1.3 Legal regulations**

<b>Labelling</b>	<b>Nameplate</b>	<b>CE-mark</b>	<b>Manufacturer</b>
	Power feedback units REVCON® RLD are unequivocally marked by the contents of the nameplate.	Conforms the EC Low Voltage Directive	ELTROPLAN-REVCON Edisonstraße 3 D-59199 Bönen
<b>Patent rights</b>	The power feedback unit <b>REVCON® RLD</b> is protected in Germany and Europe by patents: <b>Patent-No.: DE 3938654C1</b> and <b>Patent-Nr.: 90123584.6-2207</b> . Patent infringements become prosecute.		
<b>Application as directed</b>	<p><b>Power feedback unit REVCON® RLD</b></p> <ul style="list-style-type: none"> <li>• Must only be operated under the conditions prescribed in these instructions.</li> <li>• Are components             <ul style="list-style-type: none"> <li>– to feedback electrical energy</li> <li>– used for installation into a machine</li> <li>– used for assembly together with other components to from a machine</li> </ul> </li> <li>• Are electric units for the installation into control cabinets or similar enclosed operating housing.</li> <li>• Comply with the requirements of the Low-Voltage Directive</li> <li>• Are not machines for the purpose of the Machinery Directive</li> <li>• Are not to be used as domestic appliances, but only for industrial purpose.</li> </ul> <p><b>Drive systems with power feedback unit REVCON® RLD</b></p> <ul style="list-style-type: none"> <li>• Comply with the EMC-Directive if they are installed according to the guidelines of CE-typical drive systems.</li> <li>• Can be used             <ul style="list-style-type: none"> <li>– on public and non-public mains</li> <li>– in industrial as well as residential and commercial premises</li> </ul> </li> <li>• The user is responsible for the compliance of this application with the EC directives.</li> </ul>		
<b>Liability</b>	<ul style="list-style-type: none"> <li>• The information, data and notes in these Operating Instructions met the state of the art at the time of printing. Claims referring to power feedback units which have already been supplied cannot be derived from information, illustrations and descriptions given in these Operation Instructions.</li> <li>• The specifications, processes and circuitry described in these Operating Instructions are for guidance only and must be adapted to your own specific application. ELTROPLAN-REVCON does not take responsibility for the suitability of the process and circuit proposals.</li> <li>• The indications given in these Operating Instructions describe the features of the product without warranting them.</li> <li>• ELTROPLAN-REVCON does not accept any liability for damage and operating interference caused by:             <ul style="list-style-type: none"> <li>– disregarding these instructions</li> <li>– unauthorized modifications to the power feedback unit</li> <li>– operating errors</li> <li>– improper working on and with the power feedback unit</li> </ul> </li> </ul>		
<b>Warranty</b>	<ul style="list-style-type: none"> <li>• Warranty conditions: see sales and delivery conditions of ELTROPLAN-REVCON GmbH.</li> <li>• Warranty claims must be made immediately after detecting defects or faults.</li> <li>• The warranty is void in all cases where liability claims cannot be made.</li> </ul>		
<b>Disposal</b>	<b>Material</b>	<b>recycle</b>	<b>disposal</b>
	Metal	●	-
	Plastic	●	-
	Printed-board assemblies	-	●

**Preface and general information**

---

**1.4 EC-Directives / Declaration of conformity**

**What is the purpose of EC-Directives?**

The EC-Directives have been drawn up by the European council to define common technical standards and certification procedures within the European Community. At the moment there are 21 EC-Directives for product sectors. The directives are or will be converted in national laws by the member states. If a certificate is conferred in one member state, it is valid in all other member states automatically.

The directives only describe the basic standards. The technical details are or will be described in harmonized European standards.

**What is the meaning of the CE-marking?**



After a conformity-assessment-procedure the conformity with the standards of the EC-Directives is certified by fixing the CE-marking. Within the EC there are no trading obstacles for a CE-marked product.

Power feedback units with CE-mark themselves are compliant with the Low-Voltage Directive only. For observing the EMC Directive recommendations are made.

**1.4.1 EC-low voltage directive**

(73/23/EEC)

Modified by:      CE – Marking Directive      (93/68/EEC)

CE – Marking Directive      (2006/95/EEC)

**General:**

- The Low-Voltage Directive is valid for all electrical equipment which is used at a nominal voltage between 50V and 1000V AC and between 75V and 1500V DC together with customary environment conditions. Excluded is e.g. the use of electrical equipment in explosive areas and electrical components of lifts for persons or material.
- Aim of the Low-Voltage Directive is to put only those products into commerce which don't endanger the safety of persons and animals as well as the preservation of material assets.

## **EC-declaration of conformity**

### **According to the EC-Low Voltage Directive (2006/95/EEC)**

The power feedback units REVCON® RLD have been developed, designed and manufactured in accordance with the above mentioned EC-Directive and in sole responsibility of

**ELTROPLAN-REVCON Elektrotechnische Anlagen GmbH,  
 Edisonstraße 3, D-59199 Bönen**

Considered standards:

<b>Standard</b>	
DIN VDE 0160 5.88 +A1 / 4.89 +A2 / 10.88 PRDIN EN 50178 Class VDE 0160 / 11.94	Equipment of power installations with electronic components
EN 61558-1/A1	Safety of power transformers, power supplies, reactors and similar products
EN 60529	International protection rating
DIN VDE 0100	Guidelines for the design of power installations

### **1.4.2 EC-directive Electromagnetic compatibility**

EMC directive (89/336/EWG)  
 Replaced by: EMC-directive (2004/108/EG)

#### **General:**

The objective target describes article 4 (2004/108/EG), as follows:

*The... designated devices must be so manufactured, that*

*(a) an intended operation of radio- and telecommunication devices and other devices is possible and*

*(b) the devices have an adequate stability against electromagnetically disturbances, so that an intended operation is possible.*



## Preface and general information

### EG-declaration by the manufacturer

#### in terms of the EG-standard EMC (2004/108/EG)

The listed REVCON® products are in terms of the EMC no independently recoverable products, this means only after integration in the overall system would they be rateable regarding to EMC. The rating became detected for typical plant constructions, but not for the several products.

**ELTROPLAN- REVCON Elektrotechnische Anlagen GmbH,  
 Edisonstraße 3, D-59199 Bönen**

Considered standards:

Standard	
DIN EN 61000-3-3:2008 (IEC 61000-3-3:2008)	Generic standards Limits: Limitation of voltage changes, voltage fluctuations and flicker in public low-voltage supply systems
DIN EN 61000-6-2:2005 (IEC 61000-6-2:2005)	Generic standards - Immunity for industrial environments
DIN EN 61000-6-3:2007 +A1:2011 (IEC 61000-6-3:2006+A1:2010)	Generic standards - Emission standard for residential, commercial and light-industrial environments
DIN EN 61000-6-4:2007 + A1:2011 (IEC 61000-6-4:2006+A1:2010)	Generic standards - Emission standard for industrial environments

### 1.4.3 EC-directive Machinery

Machine directive (98/37/EG)  
 Changed by: Modification directive (2006/42/EG)

#### General:

*Machinery means an assembly, fitted with or intended to be fitted with a drive system other than directly applied human or animal effort, consisting of linked parts or components, at least one of which moves, and which are joined together for a specific application.*

### EC- declaration by the manufacturer

#### in terms of the EG-directive machines (2006/42/EG)

The Energy feedback units REVCON® RLD were developed, designed and manufactured in accordance to the above named EG- directive in exclusive accountability by

**ELTROPLAN-REVCON® Elektrotechnische Anlagen GmbH,  
 Edisonstraße 3, D-59199 Bönen**

The operation of the Energy feedback units REVCON® RLD is prohibited as long as it is determined, that the machine, in which it should be installed, conforms to the regulations of the EG-directive machines.

## 2 Safety information



### Safety and application notes for drive converters

(Low-Voltage Directive (2006/95/EEC))

#### 1. General

During operation, power feedback unit may have, according to their type of protection, live, bare, in some cases also movable or rotating parts as well as hot surfaces.

Non –authorized removal of required cover, inappropriate use, incorrect installation or operation, creates the risk of severe injury to persons or damage to material assets.

Further information can be obtained from the documentation.

All operations concerning transport, installation and commissioning as well as maintenance must be carried out by qualified, skilled personnel (IEC 364 and CENELEC HD 384 or DIN VDE 0100 and IEC-Report 664 or DIN VDE 0110 and national regulations for the preventions of accidents must be observed).

According to this basic safety information qualified skilled personnel are persons who are familiar with the erection, assembly, commissioning and operation of the product and who have the qualifications necessary for their occupation .

#### 2. Application as directed

Power feedback units are components which are designed for installation in electrical systems or machinery.

When installing in machines, commissioning of the power feedback unit (i.e. the starting of operation as directed) is prohibited until it is proven, that the machine corresponds to the regulations of the EC Directive (2006/42/EG) (Machinery Directive); EN 60204 must be observed.

Commissioning (i.e. starting operation as directed) is only allowed when there is compliance with the EMC-Directive (2004/108/EG).

The power feedback units meet the requirements of the Low-Voltage Directive (2006/95/EEC). The harmonized standards of the prEN 50178/DIN VDE 0160 series together with EN 60439-1/DIN VDE 0660 part 500 and EN 60146/DIN VDE 0558 are applicable for the power feedback unit. The technical data and information on the connection conditions must be obtained from the nameplate and the documentation and must be observed in all cases.

#### 3. Transport, Storage

Notes on transport, storage and appropriate handling must be observed.

At non-observance any warranty expires.

The power feedback unit has to be protected from inadmissible stress.

The transport is only valid in original packaging and in the thereon by pictograms marked transport position.

In particular during transport and handling no components are allowed to be bent and / or isolating distances may not be altered.

The units are equipped with electrostatic sensitive devices, which may be damaged by improper handling. Therefore it has to be avoided to get in contact with electronic components. If electronic components are damaged mechanically the unit must not be put into operation, as it cannot be ensured, that all relevant standards are observed. Climatic conditions must be observed according to prEN 50178.

#### 4. Erection

The devices must be erected and cooled according to the regulations of the corresponding documentation.

The power feedback units must be protected from inappropriate loads. Particularly during transport and handling, components must not be bent and / or isolating distances must not be changed. Touching of electronic components and contacts must be avoided.

Power feedback units contain electro-statically sensitive components which can easily be damaged by inappropriate handling. Electrical components must not be damaged or destroyed mechanically (health risk are possible!).

#### 5. Electrical Connection

When working on live power feedback units, the valid national regulations for the prevention of accidents (e.g. VBG 4) must be observed. Before any installation or connection works, the plant has to be switched off and to be secured properly.

The electrical installation must be carried out according to the appropriate regulations (e.g. cable cross-sections, fuses, PE-connection). More detailed information is included in the documentation. When using the power feedback unit with controllers without safe separation from the supply line (to VDE 0100) all control wiring has to be include in further protective measures (e.g. double insulated or shielded, grounded and insulated) .

Notes concerning the installation in compliance with EMC – such as screening, grounding, arrangement of filters and laying of cables – are included in the chapter installation of this documentation. These notes must be also observed in all cases for power feedback units with the CE-mark. The compliance with the required limit values demanded by the EMC legislation is the responsibility of the manufacturer of the system or machine.

#### 6. Operation

Systems where power feedback units are installed, if applicable, have to be equipped with additional monitoring and protective devices according to the valid safety regulations e.g. law on technical tools, regulations for the prevention of accidents, etc. .

After disconnecting the power feedback unit from the supply voltage, live parts of the power feedback unit and power connections must not be touched immediately, because of possibly charged capacitors. For this, observe the corresponding labels on the drive controllers.

During operation, all covers and doors must be closed.

#### 7. Maintenance and service

The manufacturer's documentation must be observed.

#### This safety information must be kept!

The product-specific safety and application notes in these Operating Instructions must also be observed!

## Safety information

---

### 2.1 General safety information

- These safety regulations are not entitled to completeness. In case of questions please contact our technicians.
- When commissioning the power feedback unit is compliant with the state of the art. The power feedback unit generally allows safe operation.
- The statements of this manual describe the attributes of the products without guaranteeing them.
- The power feedback unit may expose persons, the power feedback units itself and other material to danger, if
  - non qualified personal works at and with the power feedback unit.
  - The power feedback units are used in opposite to its purpose.
- Power feedback units have to be projected in a way, that they fulfil their function and don't expose persons to danger, if they are mounted correctly and are used in accordance with their purpose. This applies also for the interplay with the whole plant.
- The units, operational data and circuit details described in this manual have to be understood analogously and have to be checked for transferability to each application.
- For the reasons of personal safety, the observance of the EMC-regulations and for the regular cooling the operation of the device is only allowed with a closed cover of the housing and with mounted flanges!
- Use the drive system only in flawless condition.

- Modifications of the power feedback units without consultation of a REVCON<sup>®</sup>-technician are not allowed generally.
- The warranty given by us expires, if the unit is modified or (even partially) dismantled or if it is used in contradiction to our instructions.
- The constructor of the plant, who has to know the technical guidelines, bears the responsibility for the correct selection and arrangement of the electrical components.
- Putting into operation of the power feedback unit is only admissible at VDE-conform nets of electrical power supply. Non observance may damage the device!
- In accordance with the corresponding standards and guidelines the operation on even for a short time over-compensated networks ( $\cos\varphi \leq 1$ ) respectively on un-choked compensation-units is not admissible. If this is done nevertheless, overvoltage will occur (caused by oscillating currents), which may damage all connected components, especially electronic units like controllers and power feedback units.
- To low powered or unloaded generators and to regulating transformers it is never allowed to feed back power without a previous consultation of our application department. Otherwise unintended voltage rises / excess voltages are generated, which may damage or destroy REVCON<sup>®</sup> and combined units!
- Before operating at nets without reference to neutral ground additional safety measures (e.g. installation of over voltage suppressors like MOV's) have to be done. If necessary, please ask for technical support by our technicians.

---

## Safety information

---

- An undisturbed operation of the power feedback unit is only probable, if the following instructions are observed. If these instructions are not observed, tripping of the unit and damages may occur.
- Pay attention to the correct values of mains and DC-bus voltage.
- Separate power and control wires (> 15cm)
  - Use shielded or twisted control wires. Connect both ends of the shield to ground!
  - When using the digital input devices, only use suitable switching devices, whose contacts are able to switch the connected voltages.
  - Connect the housings of drive, controller and power feedback unit to ground carefully. Connect shields of power cables to ground at both ends with as big surface as possible (remove lacquer)!
  - Connect the cabinet or the plant by a star-shaped network to ground (ground loops have to be avoided!)
- The power feedback unit has been designed for a fixed connection to mains only. Especially when using RFI-filter leakage current values > 3,5mA may occur. The cross section of the earthing conductor must be at least 10mm<sup>2</sup> copper, or a second conductor has to be connected in parallel (star shaped grounding network).
- If components are used, which have no electrical separated inputs / outputs it is necessary to equalize the potentials (e.g. by an equalizing wire). If this is not observed, these components may be damaged by equalizing currents.
- When carrying out an insulations test in accordance with VDE0100/part 620 the device has to be disconnected to avoid damage to the power semiconductors. This procedure corresponds with the standard, as each device performs a high voltage test in accordance with VDE 0160 (EN 50178) in the course of final testing after manufacturing.

- A standard fault-current circuit breaker (sensitive on peak currents) is not allowed to be used as the only protective measure when using controller and power feedback unit. Caused by a DC-component in the mains current a controller with 3-phase input voltage may prevent a fault-current circuit breaker from tripping in case of a earth fault. In accordance with VDE 0160 a fault-current circuit breaker is not allowed to be used as the only protective measure. In dependence on the kind of network (TN, IT, TT) further protective measures in accordance with VDE 0100 part 410 are necessary. For a TN-network this may be an over current protection, for an IT-network an insulation supervision with pulscode-measurment. For all kind of networks protective insulation (-transformer) may be used, if required power and length of wires allow that. When selecting a fault current circuit breaker the following measures have to be considered:
  - The fault current circuit breaker has to be compliant with the VDE 0664 standard.
  - The tripping current should be 300mA or more, to prevent a premature tripping caused by the leakage current of the controller. In dependence on the load, the length of the motor cables and the usage of a RFI-filter the leakage current may even be much higher.

Fault current circuit breakers, which are sensitive to all kinds of leakage currents, grant a good protection and are suitable as the only protection measurement for one ore three phase controllers. The connection instructions of the manufacturer have to be observed.

---

## Safety information

---

### 2.2 Safety-responsible persons

#### User

- User is any natural or legal entity, who uses the drive system or by whom order the drive system is used.
- The user respectively his security officer have to grant
  - that all relevant regulations, instructions and laws have to be observed
  - that only qualified personnel works with or at the drive system
  - that the relevant manual is available for the personnel during any works
  - that non-qualified personnel are prohibited to work on the drive system

#### Qualified staff

---

##### Stop!



Qualified staff means persons, that are entitled (by the safety responsible) due to their training, experience, education, their knowledge in relevant norms, directives, accident directives and operation conditions to execute the necessary works and to recognize possible danger and to avoid it. (Definition of qualified staff IEC 364)

---

#### Intended Use

---

##### Danger!



Power feedback units are electrical drive components, which are directed to be installed in electrical plants or machines. They have to be used only for drive systems with infinity variable speed controls of 3-phase asynchronous or permanent magnet motors. The usage with other electrical loads is not permitted and may damage the devices. The power feedback unit may only be connected to symmetrical networks. Non-observance may damage the devices.

---

## 2.3 Layout of the safety information

- All safety notes have a uniform layout:
  - The icon characterizes the type of danger.
  - The signal word characterizes the severity of danger.
  - The note describes the danger and suggests how to avoid the danger.



### Signal word

Legend

	Used pictograms		Signal words	
Warning of injury to persons		Imminent danger by current	<b>Danger!</b>	Warns of an immediately imminent Danger. Consequences by disregard: Death or severe injuries
		Warning of an imminent danger	<b>Warning!</b>	Warns of a possible, very danger situation. Possible consequences by disregard: Death or severe injuries
		Dangerous situation	<b>Caution!</b>	Warns of a possible, dangerous situation. Possible consequences by disregard: Minor or small injuries
		Warning of hot surface	<b>Warning!</b>	Warns of touching a hot surface. Possible consequences by disregard: Burnings
Warning of property damages		Harmful situation	<b>Stop!</b>	Warns of possible property damages. Possible consequences by disregard: Damage of the drive system or its surroundings
Useful information and application notes		Information	<b>Note!</b>	Marks a generally, useful note, tip. If you follow it, you make the handling of the system easier

## 2.4 Residual hazards



### Operator's safety

After mains disconnections, the power terminals + and – remain live for several minutes.

### Protection of the device



Cyclic connection and disconnection of the supply voltage at terminals L1, L2 und L3, may overload the internal input current limitation:

Allow at least 1 minute between disconnection and reconnection.



## Safety information

---

### 2.5 General instructions

By this information to erectors and users of a plant hints on properties and directions concerning the power feedback unit are given. These hints are not entitled to completeness.

#### **Special features in comparison to a brake chopper:**

Unlike a braking resistor a power feedback device isn't a constant drain, but it's dependent on the momentary characteristics of the supplying net. Commutation brake downs and voltage-flicker in the net have a considerable effect to the backward current of the device. In case of a short time voltage brake down the backward current has to raise correspondingly to feedback the demanded power-amount. Does the level of the supply voltage sink for a longer time; the maximum feedback power is reduced.

If only one phase fails, the device is able to work on, but the current in the two remaining conductors will rise up to 150% of the normal level.

**Length of the DC-connection:**

The maximum inductivity of the DC-connection between output B6 Bridge of the frequency converter and the power feedback device must not exceed an assigned value, as this inductivity inducts an additional voltage to the DC-bus of the frequency converter, when the IGBT's are switched off. To avoid an overload to the components of the power feedback unit, this additional voltage must not exceed 150V.

**Maximal inductance of the DC-wire:**

Nominal voltage 400V

REVCON®-type	DC-capacitance [µF]	Maximal Inductance of the DC-Wire [mH]
RLD-E0 8-400-50-0-A	20	1,55
RLD-E0 12-400-50-0-A	20	0,68
RLD-E0 16-400-50-0-A	40	0,86
RLD-E0 20-400-50-0-A	40	0,27
RLD-E0 24-400-50-0-A	220	3,52
RLD-E0 32-400-50-0-A	220	1,76
RLD-E0 40-400-50-0-A	220	1,05
RLD-E0 48-400-50-0-A	440	1,68
RLD-E0 58-400-50-0-A	440	1,10
RLD-E0 80-400-50-0-A	440	0,52
RLD-E0 95-400-50-0-A	440	0,34
RLD-E0 116-400-50-0-A	440	0,21
RLD-E0 140-400-50-0-A	660	0,18
RLD-E0 170-400-50-0-A	660	0,09
RLD-E0 200-400-50-0-A	660	0,05
RLD-E0 230-400-50-0-A	880	0,08
RLD-E0 265-400-50-0-A	880	0,03
RLD-E0 300-400-50-0-A	880	0,04
RLD-E0 345-400-50-0-A	880	0,01

Table 2.5.1

**Safety information**

Nominal voltage 500V

<b>REVCON®-type</b>	<b>DC-capacitance [μF]</b>	<b>Maximal Inductance of the DC-Wire [mH]</b>
RLD-E0 10-500-50/60-0-A	220	58,99
RLD-E0 15-500-50/60-0-A	220	25,55
RLD-E0 20-500-50/60-0-A	220	14,00
RLD-E0 25-500-50/60-0-A	220	8,72
RLD-E0 30-500-50/60-0-A	220	5,89
RLD-E0 40-500-50/60-0-A	220	3,13
RLD-E0 50-500-50/60-0-A	220	1,88
RLD-E0 60-500-50/60-0-A	220	1,22
RLD-E0 73-500-50/60-0-A	440	1,95
RLD-E0 88-500-50/60-0-A	440	0,94
RLD-E0 100-500-50/60-0-A	440	0,63
RLD-E0 120-500-50/60-0-A	660	0,68
RLD-E0 145-500-50/60-115-A	660	0,44
RLD-E0 175-500-50/60-115-A	660	0,27
RLD-E0 213-500-50/60-115-A	880	0,28
RLD-E0 250-500-50/60-115-A	880	0,20
RLD-E0 288-500-50/60-115-A	880	0,14
RLD-E0 331-500-50/60-115-A	880	0,10
RLD-E0 375-500-50/60-115-A	880	0,06
RLD-E0 431-500-50/60-115-A	880	0,06

Table 2.5.2

### Operation on a generator

The usage of a power feedback unit within an isolated network (e.g. with a diesel generator) is possible, but there are restrictive regulations concerning the power limits.

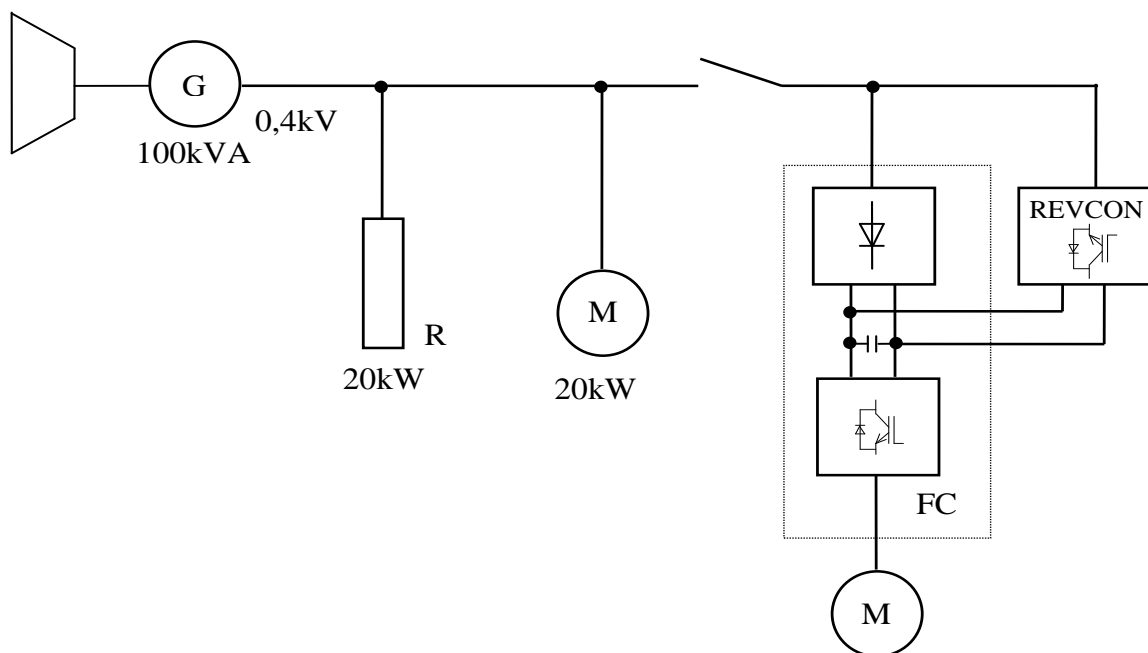

Figure 2.5.1

Within a network that is assembled like in figure 2.5.1 there are two additional restrictions: First the power of the motor connected to the inverter must be lower than half of the nominal power of the generator. Second the total amount of the power of the two other loads must be more than double of the feedback power.

If these conditions aren't checked up a change from motor to generator operation may result in load shocks. These shocks are too dynamic for the voltage regulator of the generator. The regulator reacts with an overshoot and as a result of this with an over voltage within the isolated network.

### **Danger!**



Over voltages may cause serious damages to the connected frequency inverter and /or to the power feedback unit and to the other loads.

## Safety information

### Operation on a transformer

Is the energy balance of an installation negative (e.g. for a period more braking energy is created than consumed on the secondary side of the transformer), the nominal (complex) power of the transformer must be at least 1,5 times higher than the regenerated braking power.

Generally the short circuit voltage of the transformer should be preferably small (typical 4-6%).

### **Danger!**



At non-observance of these connecting conditions overvoltage and mains voltage harmonic distortions are generated, which can lead to damages at the power feedback units and other connected components!

The above-named conditions are in the in figure 2.5.2 diagrammed mains section just observed, if the other loads are switched off.

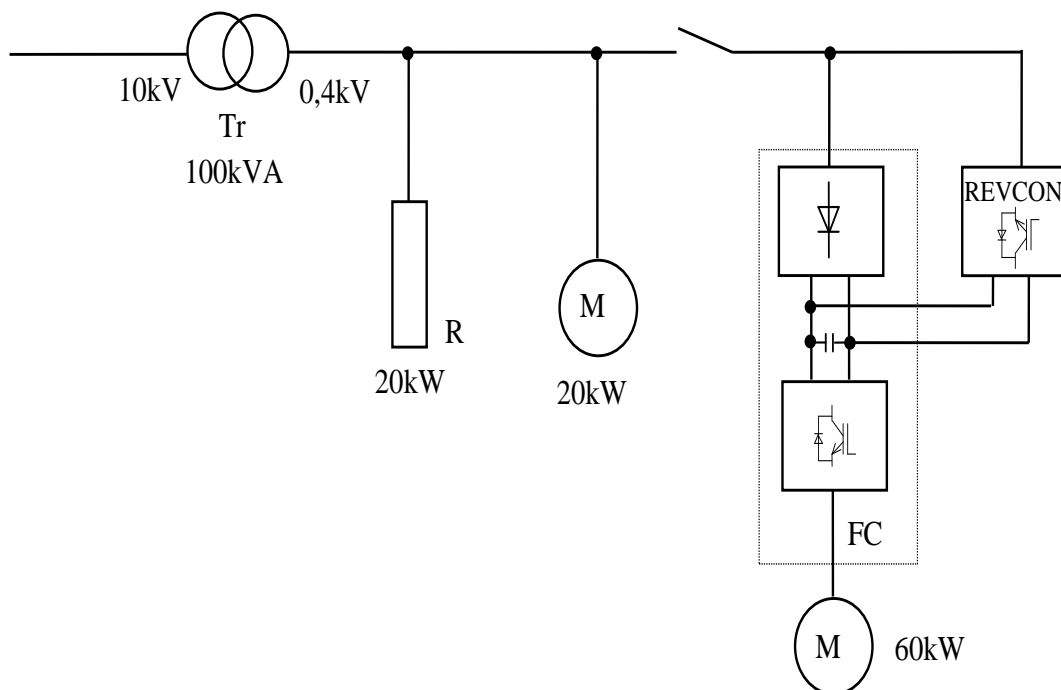

Figure 2.5.2

The mains impedance of all installed feedback units should be 2 times so large as the mains impedance, but minimum the 1,5-times of the mains impedance!

**Placing of the commutation choke**

If the frequency converter is connected to an external commutation choke, the connection of the power feedback unit has to be done at its network terminals (figure 2.5.3). If the connection is done at the load terminals of the commutation choke its inductivity prevents the synchronising to the supplying net and the induction voltage of the choke when it is switched off under load may result in damages to the power feedback device.

**Danger!**

Over voltages may cause serious damages to the connected frequency inverter and /or to the power feedback unit and to the other loads.

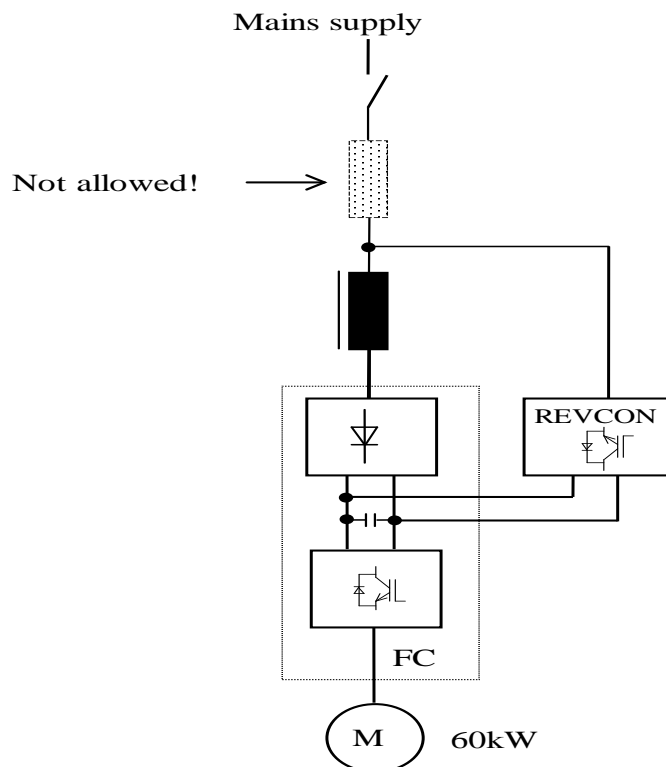

Figure 2.5.3

The same things apply to the also non-admissible pre-connection of further commutation chokes.

## Safety information

### Line and contact resistances

The values of current carrying capacity of conductors refer to the most often used copper conductors. Concerning to its higher specific resistance aluminium conductors must have greater dimensions.

Regardless of which conducting material is used, the contact terminals of the conductors have to be low resistive and their number has to be reduced to the necessary minimum.

Too much or too high resistive terminals may result in an unsafe voltage magnification during the power feedback operation.

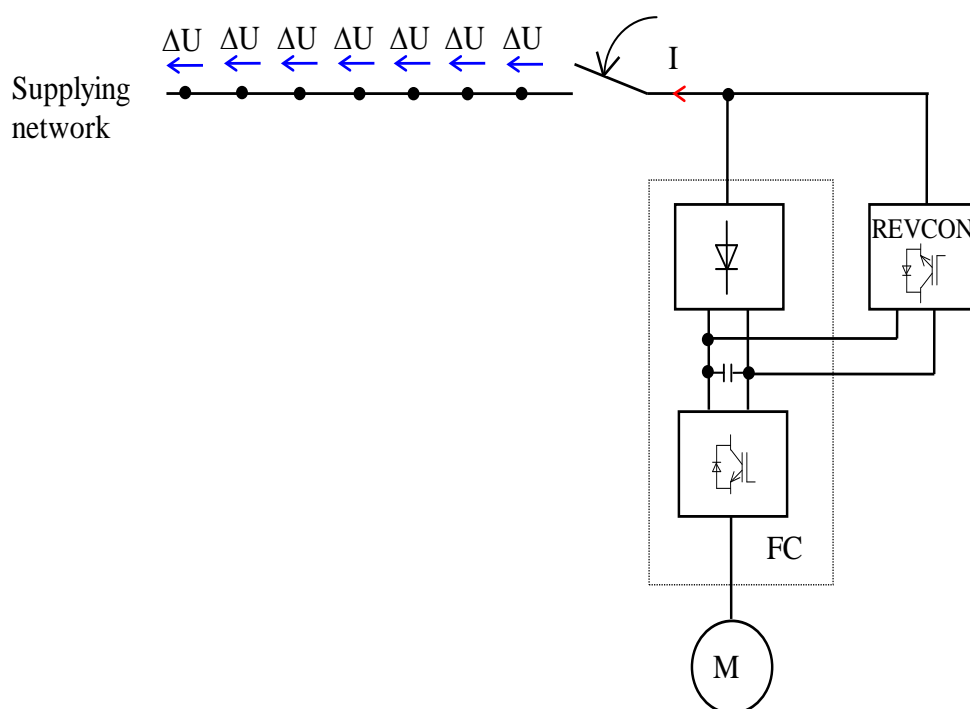

Figure 2.5.4

Proceeding from a stable network with e.g. 400V nominal voltage and a backward current of 80A, at a bad made terminal of 100mW a voltage of 8V is dropped (a good made terminal has got a resistance of ca 1 mW). During feedback operation at seven serial terminals at the net switch results a voltage of 456V.



**Danger!**

Over voltages may cause serious damages to the connected frequency converter and /or to the power feedback unit and to the other loads.

**Current capacity of copper conductors for frequency converters and power feedback operation:**

Wire cross- section [mm <sup>2</sup> ]	Conductor radius [mm]	Fuse [A]	Max. continuous current [A]
16	2,3	63	46
25	2,8	80	59
35	3,3	100	73
50	4,0	125	90
70	4,7	160	106
95	5,5	200	140
120	6,2	250	206
185	7,7	315	250
2x120	2x6,2	400	300
2x150	2x6,9	500	390
2x185	2x7,7	630	485
3x185	3x7,7	800	570
3x240	3x8,7	1000	740
4x240	4x8,7	1250	920

These values are based on a cable length of 100m and a maximum voltage drop of 5V.

Table 2.5.3



## Safety information

### Connection of further loads

The connection of further loads (e.g. cabinet ventilation or climatisation) parallel to the frequency inverter / power feedback unit at a common circuit breaker like in figure 2.6.5 is not allowed. If it's done nevertheless, in case of tripping of the circuit breaker the connection to the network (energy sink and synchronising element for the power feedback unit) misses. The IGBT's now switch the DC-voltage directly to the other loads. The resulting nearly rectangular "net"-voltage drives a current through the loads, which level and form depends on their impedance. If the power consumption of the loads is too small, the DC-voltage and also the output voltage of the power feedback unit rises during the feedback operation. This increased voltage may damage all connected components.

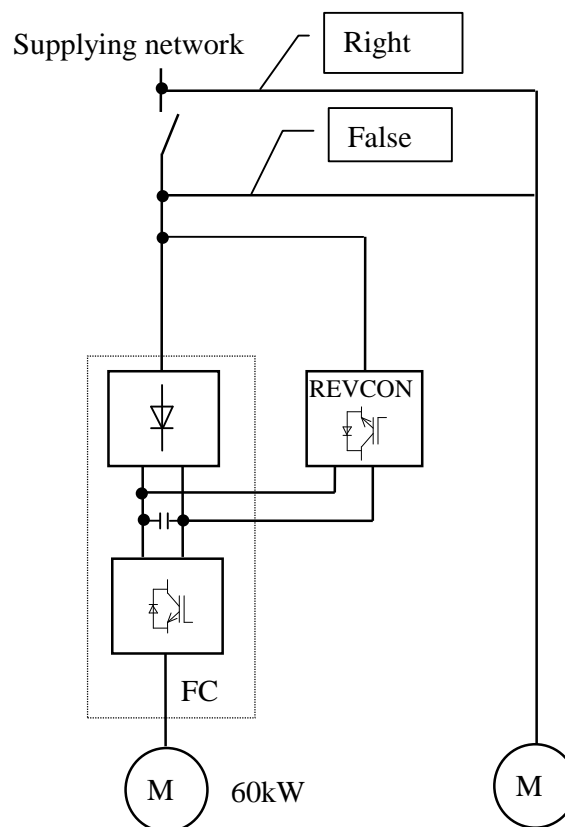

Figure 2.5.5

Safety information



**Danger!**

Over voltages may cause serious damages to the connected controller and /or to the power feed-back unit and to the other loads.

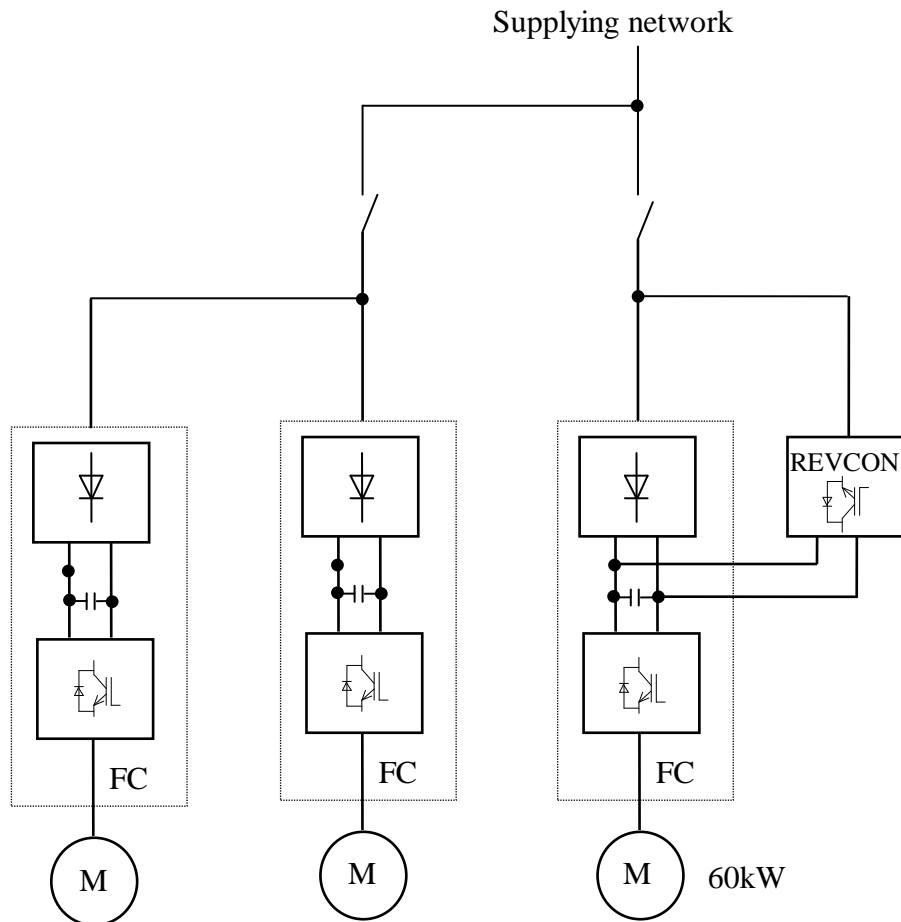

Figure 2.5.6

**Note!**



Same things apply to the structure like in figure 2.5.6. Even in this case it is necessary to place a circuit breaker in each feedback current circuit.

---

## Safety information

---

### **Unchoked compensation plants and resonance rise**

Compensation plants are used in the centre of the power supply of a company. Disturbances or damages at these plants have effects on the power supply and may result in interrupted production processes.

Although this is no longer state of the art, many compensation plants are in operation without any choking. The problems which result from a usage of such an unchoked compensation plant are manifold:

- direct resonance
- resonance rise
- switching transients or
- impairments of centralized ripple systems

The fact, that a company produces back effects to the power supply is not the only reason for the creation of resonance. Decisive for the risk, to generate a resonance is the compensation power at the medium voltage transformer. The higher this power is so higher is the risk of resonance. The second important factor is the harmonic load of the medium voltage level. This harmonic load is transmitted via the transformer and causes effects on the low voltage level. Most often the limits were exceeded for the 5th harmonic component.

### **3 Technical data**

#### **3.1 Characteristics**

- Small compact housing
- Braking power of controller is fed back into mains
- Power range 8kW to 345kW
- Up to 4 units can be paralleled (more on request)
- DC-bus coupling of several controllers possible
- IGBT power modules with high efficiency and high service reliability
- Self synchronising
- Overload protection during feedback operation
- Supervision of mains voltage, phase sequence and temperature
- High efficiency
- High dynamic braking processes are possible
- User-friendly commissioning – no adjustment necessary

## Technical data

### 3.2 General data / application conditions

Range	Values
Permissible temperature range*	During transport of the unit: -25°C...+70°C (to VDE 0160) During storage of the unit: -25°C...+55°C (to VDE 0160) During operation of the unit: 5°C... +40°C without power derating 40°C...+55°C with power derating
Humidity class*	Humidity class F without condensation (5% - 85% relative humidity)
Environment: Resonance search	Base standard: DIN EN 60068-2-6 Test specification: 5 Hz, 150 Hz, 3 directions (0,5 g, 0,1 g, 0,5 g)
Environment: Sine vibration test**	Base standard: DIN EN 60068-2-6 Test specification: (5 Hz-13,2 Hz)-150 Hz 2 mm peak to peak 0,7g
Installation height h*	H ≤ 1000 m a.m.s.l. without power derating 1000 m a.m.s.l. < h 4000 m a.m.s.l. with power derating
Air pressure*	86kPa – 106kPa to VDE0875 part 11 and prEN55082
Degree of pollution	VDE 0110 Part 2 degree 2
Noise immunity	EN 61000-4-4 degree 4 EN 61000-4-2 degree 3 EN 61000-6-2 criterion A
Insulation strength	Overvoltage category III according to VDE 0110
Packaging	DIN 55468 for transport packaging materials
Transport: Random vibration test	Base standard: DIN EN 60068-2-64 Base standard: DIN EN 30786-2
Transport: Mechanical shock test	Base standard: DIN EN 60068-2-27 Base standard: DIN EN 30786-2
Type of protection	IP 20
Approvals	CE: Low-Voltage Directive

\* Climatic conditions according to class 3K3 (EN 50178 Part 6.1)

\*\* Requirement: The specific bolting and the requirements of the operating instructions are observed!

### 3.3 Rated data

#### 3.3.1 Power feedback unit REVCON RLD E0

REVCON type		RLD E0 400V	RLD E0 500V
Nominal range of the interlinked mains voltage	$U_N[V]$	400V	440V – 500V
Tolerance of the interlinked mains voltage	$U_N[V]$	-15% / +10%	
Mains frequency	$f_N[Hz]$	50 / 60 ± 2 %	
Overload capability		ca. 1,2 x $I_{rms}$	
Efficiency	$\eta[%]$	Ca. 98 %	
Power factor	$\cos\varphi$	~ 1	
Fundamental Frequency component	g	~ 0,7- 0,95	
* <sup>1</sup> Required airflow	m <sup>3</sup> / h	a) RLD E0 008-400, 010-500, 012-400, 015-500, 016-400, 016-460, 020-400, 020-500, 024-400, 025-500, 032-400, 030-500, 040-400,040-500 : 200 b) RLD E0 048-400, 050-500, 058-400, 060-500, 080-400, 073-500, 095-400, 088-500, 116-400,100-500 : 350 c) RLD E0 140-400, 120-500, 170-400, 145-500, 200-400, 175-500 : 450 d) RLD E0 230-400, 213-500, 265-400, 250-500, 305-400, 288-500, 345-400, 331-500, 375-500, 431-500 : 700	
Power derating	[%/K]	$40^{\circ}C < T_a < 55^{\circ}C \Rightarrow 3\%/K$	
	[%/m]	$1000m \text{ a.m.s.l.} < h \leq 4000m \text{ a.m.s.l.} \Rightarrow 5\%/1000m$	

Table 3.3.1.1

\*<sup>1</sup> Depending on the size of the unit (nominal power and nominal voltage)

## Technical data

### Note!

To calculate the correct value of regenerating power it is necessary to note, that the real momentary regenerating power is dependent on the real existing main circuit voltage at any time. To calculate the regenerative power the following formula should be used:

$$P = U_{\text{eff}} \cdot I_{\text{eff}} \cdot \sqrt{3} \cdot \cos\varphi \quad (\text{during feedback operation } \cos\varphi = 1 \text{ is valid})$$

The maximum possible regenerative power is calculated based on the momentary RMS mains voltage and the maximum RMS current of the respective device.



For example:

Device type RLD E0 48 with rated feedback power of 48kW, maximum rated RMS current 69A (refer to technical data), nominal mesh voltage rating 400V.

From that results:  $P=400V \times 69A \times \sqrt{3}=47805W$ , that's about 48,0kW

If the momentary RMS mains voltage is only 395V or even lower for a short time, the maximum possible regenerative power is reduced as well:

$$P = 395V \times 69A \times \sqrt{3} = 47207W, \text{ that's about } 47,2kW.$$

### REVCON RLD E0

Nominal voltage 400V

REVCON® - type	AC Max. current $I_{\text{rms}}$ [A]	DC Max. current I [A]	REVCON Article- Number
RLD-E0 8-400-50-0-A	12	14	21016001
RLD-E0 12-400-50-0-A	17	20	21016002
RLD-E0 16-400-50-0-A	23	28	21016003
RLD-E0 20-400-50-0-A	29	35	21016004
RLD-E0 24-400-50-0-A	35	42	21016005
RLD-E0 32-400-50-0-A	46	55	21016006
RLD-E0 40-400-50-0-A	58	70	21016007
RLD-E0 48-400-50-0-A	69	83	21016008
RLD-E0 58-400-50-0-A	84	101	21016009
RLD-E0 80-400-50-0-A	116	139	21016010
RLD-E0 95-400-50-0-A	137	165	21016011
RLD-E0 116-400-50-0-A	168	202	21016012
RLD-E0 140-400-50-0-A	202	242	21016013
RLD-E0 170-400-50-0-A	246	295	21016014
RLD-E0 200-400-50-0-A	290	348	21016015
RLD-E0 230-400-50-0-A	332	398	21016016
RLD-E0 265-400-50-0-A	383	460	21016017
RLD-E0 300-400-50-0-A	434	521	21016018
RLD-E0 345-400-50-0-A	500	600	21016019

Table 3.3.1.2

**Technical data**

Nominal voltage 500V

<b>REVCON<sup>®</sup> - type</b>	<b>AC Max. current <math>I_{rms}</math> [A]</b>	<b>DC Max. current I [A]</b>	<b>REVCON Article- Number</b>
RLD-E0 10-500-50/60-0-A	12	14	21016121
RLD-E0 15-500-50/60-0-A	17	21	21016122
RLD-E0 20-500-50/60-0-A	23	28	21016123
RLD-E0 25-500-50/60-0-A	29	35	21016124
RLD-E0 30-500-50/60-0-A	35	42	21016125
RLD-E0 40-500-50/60-0-A	46	56	21016126
RLD-E0 50-500-50/60-0-A	58	70	21016127
RLD-E0 60-500-50/60-0-A	69	84	21016128
RLD-E0 73-500-50/60-0-A	84	101	21016129
RLD-E0 88-500-50/60-0-A	101	122	21016130
RLD-E0 100-500-50/60-0-A	115	140	21016131
RLD-E0 120-500-50/60-0-A	138	167	21016132
RLD-E0 145-500-50/60-230/115-A	167	203	21016133
RLD-E0 175-500-50/60-230/115-A	202	245	21016134
RLD-E0 213-500-50/60-230/115-A	245	297	21016135
RLD-E0 250-500-50/60-230/115-A	289	350	21016136
RLD-E0 288-500-50/60-230/115-A	332	402	21016137
RLD-E0 331-500-50/60-230/115-A	382	463	21016138
RLD-E0 375-500-50/60-230/115-A	433	525	21016139
RLD-E0 431-500-50/60-230/115-A	498	603	21016140

Table 3.3.1.3



## Technical data

### 3.4 Fuses and wire cross sections

The power feed/feedback unit is connected to mains supply via the terminals L<sub>1</sub>-L<sub>3</sub> at the connection plate. Mains fuses must be designed according to the current load capacity of the supply wire.

#### Stop!



If semiconductor fuses (figure 4.4.1.1 position 1 and 3) trip, please get in contact with ELTROPLAN-REVCON immediately, as possibly further protective measures have tripped. If internal fuses are exchanged, please verify that only the original types are used for replacement.



#### Danger!

Before replacing a fuse, switch off all voltages!

Semiconductor fuses have to be connected in series with the power feedback unit as following tables (refer to figure 4.4.1.1 position 1 and/or 3). The listed manufacturer is recommended, but naturally also comparative fuses of other manufacturer (e.g. Jean Müller, Ferraz, and Bussmann) are suitable.

#### Series fuses REVCON RLD E0

Nominal voltage 400V

REVCON® - type RLD E0	Max. fuse AC		
8-400-50-0-A	Siba 5012406.20	20A	690V 10x38mm
12-400-50-0-A	Siba 5017906.30	30A	690V 14x51mm
16-400-50-0-A	Siba 5012406.50	50A	690V 14x51mm
20-400-50-0-A	Siba 5012406.50	50A	690V 14x51mm
24-400-50-0-A	Siba 5012406.50	50A	690V 14x51mm
32-400-50-0-A	Siba 5014006.80	80A	690V 22x58mm
48-400-50-0-A	Siba 5014006.100	100A	690V 22x58mm
58-400-50-0-A	Siba 2018920.160	160A	690V NH 00
80-400-50-0-A	Siba 2018920.160	160A	690V NH 00
95-400-50-0-A	Siba 2018920.200	200A	690V NH 00
116-400-50-0-A	Siba 2018920.315	315A	690V NH 00
140-400-50-0-A	Siba 2018920.315	315A	690V NH 00
170-400-50-0-A	Siba 2071332.400	400A	1100V NH 01
200-400-50-0-A	Siba 2071332.500	500A	1100V NH 01
230-400-50-0-A	Siba 2071332.500	500A	1100V NH 01
265-400-50-0-A	Siba 2071332.500	500A	1100V NH 01
300-400-50-0-A	Siba 2071332.630	630A	1100V NH 01
345-400-50-0-A	Siba 2071332.630	630A	1100V NH 01

Table 3.4.1

Nominal voltage 500V

<b>REVCON® - type RLD E0</b>	<b>Max. fuse AC</b>
10-500-50/60-0-A	Siba 5012406.20 20A 690V 10x38mm
15-500-50/60-0-A	Siba 5017906.30 30A 690V 14x51mm
20-500-50/60-0-A	Siba 5012406.50 50A 690V 14x51mm
25-500-50/60-0-A	Siba 5012406.50 50A 690V 14x51mm
30-500-50/60-0-A	Siba 5012406.50 50A 690V 14x51mm
40-500-50/60-0-A	Siba 5014006.100 100A 690V 22x58mm
50-500-50/60-0-A	Siba 5014006.100 100A 690V 22x58mm
60-500-50/60-0-A	Siba 2018920.160 160A 690V NH 00
73-500-50/60-0-A	Siba 2018920.160 160A 690V NH 00
88-500-50/60-0-A	Siba 2018920.200 200A 690V NH 00
100-500-50/60-0-A	Siba 2018920.315 315A 690V NH 00
120-500-50/60-0-A	Siba 2018920.315 315A 690V NH 00
145-500-50/60-230/115-A	Siba 2018920.315 315A 690V NH 00
175-500-50/60-230/115-A	Siba 2071332.400 400A 1100V NH 01
213-500-50/60-230/115-A	Siba 2071332.500 500A 1100V NH 01
250-500-50/60-230/115-A	Siba 2071332.500 500A 1100V NH 01
288-500-50/60-230/115-A	Siba 2071332.630 630A 1100V NH 01
331-500-50/60-230/115-A	Siba 2071332.630 630A 1100V NH 01
375-500-50/60-230/115-A	Siba 2071332.630 630A 1100V NH 01
431-500-50/60-230/115-A	Siba 2071332.630 630A 1100V NH 01

Table 3.4.2

## Technical data

### DC- fuses REVCON RLD B0

It is recommended to protect the power feedback unit is equipped with semiconductor fuses according to the following tables (refer to figure 4.4.1.1 position 9). The listed manufacturer is recommended, but naturally also comparative fuses of other manufacturer (e.g. Jean Müller, Ferraz, and Bussmann) are suitable.

#### Stop!



If semiconductor fuses trip, please get in contact with ELTROPLAN-REVCON immediately, as possibly further protective measures have tripped. If fuses are exchanged, please verify that only the original types are used for replacement.



#### Danger!

Before replacing a fuse, switch off all voltages!

REVCON® - type	DC-fuses (use fast acting semiconductor fuses only)
RLD E0- 25-500-50/60-0-A	Siba 5012406.50 50A 690V 14x51mm
RLD E0- 50-500-50/60-0-A	Siba 5014006.100 100A 690V 22x58mm
RLD E0- 120-500-50/60-0-A	Siba 2018920.250 250A 690V NH 00
RLD B0- 213-500-50/60-230/115-A	Siba 2071332.500 500A 690V SQB 1
RLD B0- 431-500-50/60-230/115-A	Siba 20 723 32.800 800A 690V SQB 2

Table 3.4.3

### 3.5 RFI-filter REVCON RLD E0

All power feedback units observe the category C3 “Industrial environments” corresponding to the product standard EN 61800-3. For the compliance of the category C2 “Residential, business and industrial environments” a RFI-filter can be connected to the power feedback unit according to figure 4.4.1.1 to 4.4.1.3.

The power feedback units are assigned to the corresponding RFI-filter types in the tables 3.5.1.1 to 3.5.1.2.

<b>REVCON® - type RLD E0</b>	<b>Order designation filter</b>	<b>Item-Number</b>	<b>Max. Mains connection RFI cross-section [mm<sup>2</sup>]</b>
8-400-50-0-A	RFI-RA 01	31300101	25
12-400-50-0-A	RFI-RA 01	31300101	25
16-400-50-0-A	RFI-RA 01	31300101	25
20-400-50-0-A	RFI-RA 01	31300101	25
24-400-50-0-A	RFI-RA 02	31300104	25
32-400-50-0-A	RFI-RA 02	31300104	25
48-400-50-0-A	RFI-RA 02	31300104	25
58-400-50-0-A	RFI-RA 13	31300105	25
80-400-50-0-A	RFI-RA 13	31300105	25
95-400-50-0-A	RFI-RA X5	31300106	70
116-400-50-0-A	RFI-RA X6	31300107	150 (M10)
140-400-50-0-A	RFI-RA X6	31300107	150 (M10)
170-400-50-0-A	RFI-RA X6	31300107	150 (M10)
200-400-50-0-A	RFI-RA X6	31300107	150 (M10)
230-400-50-0-A	RFI-RA X6	31300107	150 (M10)
265-400-50-0-A	RFI-RA X6	31300107	150 (M10)
300-400-50-0-A	RFI-RA X7	31300108	150 (M10)
345-400-50-0-A	RFI-RA X8	31300109	150 (M10)

Table 3.5.1.1

**Technical data**

<b>REVCON® - type RLD E0</b>	<b>Order designation filter</b>	<b>Item-Number</b>	<b>Max. Mains connection RFI cross-section [mm<sup>2</sup>]</b>
10-500-50/60-0-A	RFI-RA 01	31300101	25
15-500-50/60-0-A	RFI-RA 01	31300101	25
20-500-50/60-0-A	RFI-RA 01	31300101	25
25-500-50/60-0-A	RFI-RA 01	31300101	25
30-500-50/60-0-A	RFI-RA 02	31300104	25
40-500-50/60-0-A	RFI-RA 02	31300104	25
50-500-50/60-0-A	RFI-RA 02	31300104	25
60-500-50/60-0-A	RFI-RA 02	31300104	25
73-500-50/60-0-A	RFI-RA 13	31300105	25
88-500-50/60-0-A	RFI-RA 13	31300105	25
100-500-50/60-0-A	RFI-RA 13	31300105	25
120-500-50/60-0-A	RFI-RA X6	31300107	150 (M10)
145-500-50/60-230/115-A	RFI-RA X6	31300107	150 (M10)
175-500-50/60-230/115-A	RFI-RA X6	31300107	150 (M10)
213-500-50/60-230/115-A	RFI-RA X6	31300107	150 (M10)
250-500-50/60-230/115-A	RFI-RA X6	31300107	150 (M10)
288-500-50/60-230/115-A	RFI-RA X6	31300107	150 (M10)
331-500-50/60-230/115-A	RFI-RA X7	31300108	150 (M10)
375-500-50/60-230/115-A	RFI-RA X7	31300108	150 (M10)
431-500-50/60-230/115-A	RFI-RA X8	31300109	150 (M10)

Table 3.5.1.2

### 3.6 Harmonic filter module RHF-RA module

To decrease the low frequency harmonic back effects to mains a filter module REVCON® RHF-RA can be connected to the power feedback unit according figure 4.4.1.2 and 4.4.1.3.\* In the tables 3.6.1.1 and 3.6.1.2 the corresponding filter modules are listed for the power feedback unit. Provided that the total harmonic distortion of the unaffected mains voltage THD U is smaller as 2% and the ratio of short circuit power and installed power  $R_{SCE}$  is at least 66, the THD I of the mains current of the power feedback unit is reduced to typical 16%.

\* Only in connection with option EST

REVCON® - type	Ordering code RHF- module	REVCON® - item number	Case type	Fan
RLD-E0 8-400-50-0-A	RHF-RA 10-400-50-20-A	25070001	X1	-
RLD-E0 12-400-50-0-A	RHF-RA 14-400-50-20-A	25070002	X1	inside
RLD-E0 16-400-50-0-A	RHF-RA 22-400-50-20-A	25070003	X2	inside
RLD-E0 20-400-50-0-A	RHF-RA 22-400-50-20-A	25070003	X2	inside
RLD-E0 24-400-50-0-A	RHF-RA 29-400-50-20-A	25070004	X3	inside
RLD-E0 32-400-50-0-A	RHF-RA 43-400-50-20-A	25070007	X3	inside
RLD-E0 40-400-50-0-A	RHF-RA 58-400-50-20-A	25070008	X4	inside
RLD-E0 48-400-50-0-A	RHF-RA 58-400-50-20-A	25070008	X4	inside
RLD-E0 58-400-50-0-A	RHF-RA 72-400-50-20-A	25070009	X4	inside
RLD-E0 80-400-50-0-A	RHF-RA 101-400-50-20-A	25070011	X5	inside
RLD-E0 95-400-50-0-A	RHF-RA 144-400-50-20-A	25070012	X6	inside
RLD-E0 116-400-50-0-A	RHF-RA 144-400-50-20-A	25070012	X6	inside
RLD-E0 140-400-50-0-A	RHF-RA 180-400-50-20-A	25070013	X6	inside
RLD-E0 170-400-50-0-A	RHF-RA 217-400-50-20-A	25070014	X7	inside
RLD-E0 200-400-50-0-A	RHF-RA 252-400-50-20-A	25070015	X7	inside
RLD-E0 230-400-50-0-A	RHF-RA 304-400-50-20-A	25070016	X7	inside
RLD-E0 265-400-50-0-A	RHF-RA 304-400-50-20-A	25070016	X7	inside
RLD-E0 300-400-50-0-A	RHF-RA 380-400-50-20-A	25070018	X7	inside
RLD-E0 345-400-50-0-A	RHF-RA 433-400-50-20-A	25070019	X8	inside

Table 3.6.1.1

**Technical data**

<b>REVCON® - type</b>	<b>Ordering code RHF- module</b>	<b>REVCON® - item number</b>	<b>Case type</b>	<b>Fan</b>
RLD-E0 10-500-50/60-0-A	RHF-RA 15-500-50-20-A		X3	inside
RLD-E0 15-500-50/60-0-A	RHF-RA 20-500-50-20-A		X3	inside
RLD-E0 20-500-50/60-0-A	RHF-RA 20-500-50-20-A		X3	inside
RLD-E0 25-500-50/60-0-A	RHF-RA 24-500-50-20-A		X3	inside
RLD-E0 30-500-50/60-0-A	RHF-RA 29-500-50-20-A		X4	inside
RLD-E0 40-500-50/60-0-A	RHF-RA 36-500-50-20-A		X4	inside
RLD-E0 50-500-50/60-0-A	RHF-RA 50-500-50-20-A		X5	inside
RLD-E0 60-500-50/60-0-A	RHF-RA 58-500-50-20-A		X5	inside
RLD-E0 73-500-50/60-0-A	RHF-RA 77-500-50-20-A		X6	inside
RLD-E0 88-500-50/60-0-A	RHF-RA 87-500-50-20-A		X6	inside
RLD-E0 100-500-50/60-0-A	RHF-RA 109-500-50-20-A		X6	inside
RLD-E0 120-500-50/60-0-A	RHF-RA 109-500-50-20-A		X6	inside
RLD-E0 145-500-50/60-230/115-A	RHF-RA 155-500-50-20-A		X7	inside
RLD-E0 175-500-50/60-230/115-A	RHF-RA 197-500-50-20-A		X7	inside
RLD-E0 213-500-50/60-230/115-A	RHF-RA 197-500-50-20-A		X7	inside
RLD-E0 250-500-50/60-230/115-A	RHF-RA 240-500-50-20-A		X8	inside
RLD-E0 288-500-50/60-230/115-A	RHF-RA 296-500-50-20-A		X8	inside
RLD-E0 331-500-50/60-230/115-A	RHF-RA 366-500-50-20-A		X8	Outside
RLD-E0 375-500-50/60-230/115-A	RHF-RA 366-500-50-20-A		X8	Outside
RLD-E0 431-500-50/60-230/115-A	RHF-RA 395-500-50-20-A		X8	Outside

Table 3.6.1.2

## 4 Installation

### 4.1 Mechanical installation

#### 4.1.1 Important hints

- Use the power feedback units as build-in devices only!
- Observe free spaces!
  - Several power feedback units in one cabinet may be installed next to each other without spacing.
  - Keep a horizontal distance of at least 70mm to other components and to the cabinet walls.
  - Keep a vertical distance of at least 150mm to other components and to the cabinet walls.
- Ensure that there are no obstacles in the way of the cooling air input and output.
- If the cooling air is polluted (dust, dirt swirl, grease, aggressive gas ) so that the function of the power feedback unit may be impeded
  - Take sufficient countermeasures, e.g. separate cooling air, mounting of air filters, periodical cleaning.
- Do not exceed the ambient temperature permissible during operation.

#### **Provided mounting position**

The power feedback unit has been designed for vertical wall mounting ( $\pm 15^\circ$ ) only. Mounting is allowed only on a flat surface without using any kind of spacers. This kind of mounting is necessary to guarantee the right way for the cooling air. A power loss of ca. 3 % from the maximum nominal power rating has to be calculated. Air-temperature may not exceed 40 °C near the unit. Air-in- and air-out-openings at the top and the bottom of the unit may not be concealed by installation materials such as cable ducts or other equipment. Keep a distance of min. 15 cm to the air-in- and air-out-openings and a distance of min. 7 cm to beside mounted parts or cabinet-walls.



## Installation

### 4.2 Figures and facts

#### 4.2.1 Dimensions, weight and power loss

Nominal voltage 400V

REVCON® Type	Dimensions			Enclosure	Weight [kg]	Power loss* [W]
	Height [mm]	Width [mm]	Depth [mm]			
RLD-E0 8-400-50-0-A	432	240	240	0/340	16	50
RLD-E0 12-400-50-0-A	432	240	240	0/340	17	80
RLD-E0 16-400-50-0-A	432	240	240	0/340	18	100
RLD-E0 20-400-50-0-A	432	240	240	0/340	18	120
RLD-E0 24-400-50-0-A	494	240	275	0/400	18	145
RLD-E0 32-400-50-0-A	494	240	275	0/400	22	170
RLD-E0 40-400-50-0-A	494	240	275	0/400	23	250
RLD-E0 48-400-50-0-A	611	256	315	1/501	27	280
RLD-E0 58-400-50-0-A	611	256	315	1/501	28	340
RLD-E0 80-400-50-0-A	611	256	315	1/501	30	415
RLD-E0 95-400-50-0-A	611	256	315	1/501	35	500
RLD-E0 116-400-50-0-A	611	256	315	1/501	38	600
RLD-E0 140-400-50-0-A	836	256	320	2/701	52	650
RLD-E0 170-400-50-0-A	836	256	320	2/701	60	780
RLD-E0 200-400-50-0-A	836	256	320	2/701	68	1.014
RLD-E0 230-400-50-0-A	889	378	390	3/800	100	1.160
RLD-E0 265-400-50-0-A	889	378	390	3/800	115	1.300
RLD-E0 300-400-50-0-A	995	378	390	3/801	118	1.600
RLD-E0 345-400-50-0-A	995	378	390	3/801	125	1.850

Table 4.2.1.1

Nominal voltage 500V

REVCON® Type	Dimensions			Enclosure	Weight [kg]	Power loss* [W]
	Height [mm]	Width [mm]	Depth [mm]			
RLD-E0 10-500-50/60-0-A	453	240	275	0/341	17	70
RLD-E0 15-500-50/60-0-A	453	240	275	0/341	18	85
RLD-E0 20-500-50/60-0-A	453	240	275	0/341	19	100
RLD-E0 25-500-50/60-0-A	453	240	275	0/341	19	125
RLD-E0 30-500-50/60-0-A	494	240	275	0/400	19	150
RLD-E0 40-500-50/60-0-A	494	240	275	0/400	22	200
RLD-E0 50-500-50/60-0-A	494	240	275	0/400	23	300
RLD-E0 60-500-50/60-0-A	494	240	275	0/400	27	360
RLD-E0 73-500-50/60-0-A	611	256	315	1/501	28	410
RLD-E0 88-500-50/60-0-A	611	256	315	1/501	30	500
RLD-E0 100-500-50/60-0-A	611	256	315	1/501	35	680
RLD-E0 120-500-50/60-0-A	611	256	315	1/501	38	750
RLD-E0 145-500-50/60-230/115-A	836	256	320	2/701	52	900
RLD-E0 175-500-50/60-230/115-A	836	256	320	2/701	60	1.050
RLD-E0 213-500-50/60-230/115-A	836	256	320	2/701	68	1.150
RLD-E0 250-500-50/60-230/115-A	836	256	320	2/701	100	1.300
RLD-E0 288-500-50/60-230/115-A	889	378	390	3/800	115	1.530
RLD-E0 331-500-50/60-230/115-A	995	378	390	3/801	118	1.850
RLD-E0 375-500-50/60-230/115-A	995	378	390	3/801	125	2.000
RLD-E0 431-500-50/60-230/115-A	995	378	390	3/801	135	2.000

Table 4.2.1.2

\*At nominal feedback power

## Installation

### 4.2.2 Maximum cross section, screws and tightening torque

Nominal voltage 400V

<b>REVCON® - type RLD E0</b>	<b>Max. Cross section and tightening torque of the AC connection</b>	<b>Max. Cross section and tightening torque of the DC connection</b>	<b>Enclosure mounting screw and tightening torque</b>
8-400-50-0-A	16mm <sup>2</sup> / 2Nm	35mm <sup>2</sup> / 3,7Nm	4 • M6 (8.8) / 10Nm
12-400-50-0-A	16mm <sup>2</sup> / 2Nm	35mm <sup>2</sup> / 3,7Nm	4 • M6 (8.8) / 10Nm
16-400-50-0-A	16mm <sup>2</sup> / 2Nm	35mm <sup>2</sup> / 3,7Nm	4 • M6 (8.8) / 10Nm
20-400-50-0-A	16mm <sup>2</sup> / 2Nm	35mm <sup>2</sup> / 3,7Nm	4 • M6 (8.8) / 10Nm
24-400-50-0-A	50mm <sup>2</sup> / 10Nm	50mm <sup>2</sup> / 10Nm	4 • M6 (8.8) / 10Nm
32-400-50-0-A	50mm <sup>2</sup> / 10Nm	50mm <sup>2</sup> / 10Nm	4 • M6 (8.8) / 10Nm
48-400-50-0-A	50mm <sup>2</sup> / 10Nm	50mm <sup>2</sup> / 10Nm	4 • M6 (8.8) / 10Nm
58-400-50-0-A	95mm <sup>2</sup> / 20Nm	150mm <sup>2</sup> / 24Nm	4 • M6 (8.8) / 10Nm
80-400-50-0-A	95mm <sup>2</sup> / 20Nm	150mm <sup>2</sup> / 24Nm	4 • M6 (8.8) / 10Nm
95-400-50-0-A	95mm <sup>2</sup> / 20Nm	150mm <sup>2</sup> / 24Nm	4 • M6 (8.8) / 10Nm
116-400-50-0-A	95mm <sup>2</sup> / 20Nm	150mm <sup>2</sup> / 24Nm	4 • M6 (8.8) / 10Nm
140-400-50-0-A	95mm <sup>2</sup> / 20Nm	150mm <sup>2</sup> / 24Nm	4 • M6 (8.8) / 10Nm
170-400-50-0-A	150mm <sup>2</sup> / 24Nm	240mm <sup>2</sup> / 45Nm	6 • M6 (8.8) / 10Nm
200-400-50-0-A	150mm <sup>2</sup> / 24Nm	240mm <sup>2</sup> / 45Nm	6 • M6 (8.8) / 10Nm
230-400-50-0-A	150mm <sup>2</sup> / 24Nm	240mm <sup>2</sup> / 45Nm	6 • M6 (8.8) / 10Nm
265-400-50-0-A	240mm <sup>2</sup> / 30Nm	240mm <sup>2</sup> / 30Nm	6 • M8 (8.8) / 25Nm
300-400-50-0-A	240mm <sup>2</sup> / 30Nm	240mm <sup>2</sup> / 30Nm	6 • M8 (8.8) / 25Nm
345-400-50-0-A	240mm <sup>2</sup> / 30Nm	240mm <sup>2</sup> / 30Nm	6 • M8 (8.8) / 25Nm

Table 4.2.2.1

Nominal voltage 500V

<b>REVCON® - type RLD E0</b>	<b>Max. Cross section and tightening torque of the AC connection</b>	<b>Max. Cross section and tightening torque of the DC connection</b>	<b>Enclosure mounting screw and tightening torque</b>
10-500-50/60-0-A	16mm <sup>2</sup> / 2Nm	35mm <sup>2</sup> / 3,7Nm	4 • M6 (8.8) / 10Nm
15-500-50/60-0-A	16mm <sup>2</sup> / 2Nm	35mm <sup>2</sup> / 3,7Nm	4 • M6 (8.8) / 10Nm
20-500-50/60-0-A	16mm <sup>2</sup> / 2Nm	35mm <sup>2</sup> / 3,7Nm	4 • M6 (8.8) / 10Nm
25-500-50/60-0-A	16mm <sup>2</sup> / 2Nm	35mm <sup>2</sup> / 3,7Nm	4 • M6 (8.8) / 10Nm
30-500-50/60-0-A	50mm <sup>2</sup> / 10Nm	50mm <sup>2</sup> / 10Nm	4 • M6 (8.8) / 10Nm
40-500-50/60-0-A	50mm <sup>2</sup> / 10Nm	50mm <sup>2</sup> / 10Nm	4 • M6 (8.8) / 10Nm
50-500-50/60-0-A	50mm <sup>2</sup> / 10Nm	50mm <sup>2</sup> / 10Nm	4 • M6 (8.8) / 10Nm
60-500-50/60-0-A	50mm <sup>2</sup> / 10Nm	50mm <sup>2</sup> / 10Nm	4 • M6 (8.8) / 10Nm
73-500-50/60-0-A	95mm <sup>2</sup> / 20Nm	150mm <sup>2</sup> / 24Nm	4 • M6 (8.8) / 10Nm
88-500-50/60-0-A	95mm <sup>2</sup> / 20Nm	150mm <sup>2</sup> / 24Nm	4 • M6 (8.8) / 10Nm
100-500-50/60-0-A	95mm <sup>2</sup> / 20Nm	150mm <sup>2</sup> / 24Nm	4 • M6 (8.8) / 10Nm
120-500-50/60-0-A	95mm <sup>2</sup> / 20Nm	150mm <sup>2</sup> / 24Nm	4 • M6 (8.8) / 10Nm
145-500-50/60-230/115-A	150mm <sup>2</sup> / 24Nm	240mm <sup>2</sup> / 45Nm	6 • M6 (8.8) / 10Nm
175-500-50/60-230/115-A	150mm <sup>2</sup> / 24Nm	240mm <sup>2</sup> / 45Nm	6 • M6 (8.8) / 10Nm
213-500-50/60-230/115-A	150mm <sup>2</sup> / 24Nm	240mm <sup>2</sup> / 45Nm	6 • M6 (8.8) / 10Nm
250-500-50/60-230/115-A	150mm <sup>2</sup> / 24Nm	240mm <sup>2</sup> / 45Nm	6 • M6 (8.8) / 10Nm
288-500-50/60-230/115-A	240mm <sup>2</sup> / 30Nm	240mm <sup>2</sup> / 30Nm	6 • M8 (8.8) / 25Nm
331-500-50/60-230/115-A	240mm <sup>2</sup> / 30Nm	240mm <sup>2</sup> / 30Nm	6 • M8 (8.8) / 25Nm
375-500-50/60-230/115-A	240mm <sup>2</sup> / 30Nm	240mm <sup>2</sup> / 30Nm	6 • M8 (8.8) / 25Nm
431-500-50/60-230/115-A	240mm <sup>2</sup> / 30Nm	240mm <sup>2</sup> / 30Nm	6 • M8 (8.8) / 25Nm

Table 4.2.2.2

## Installation

### 4.2.3 Dimensions

#### 1. Enclosure 0/340

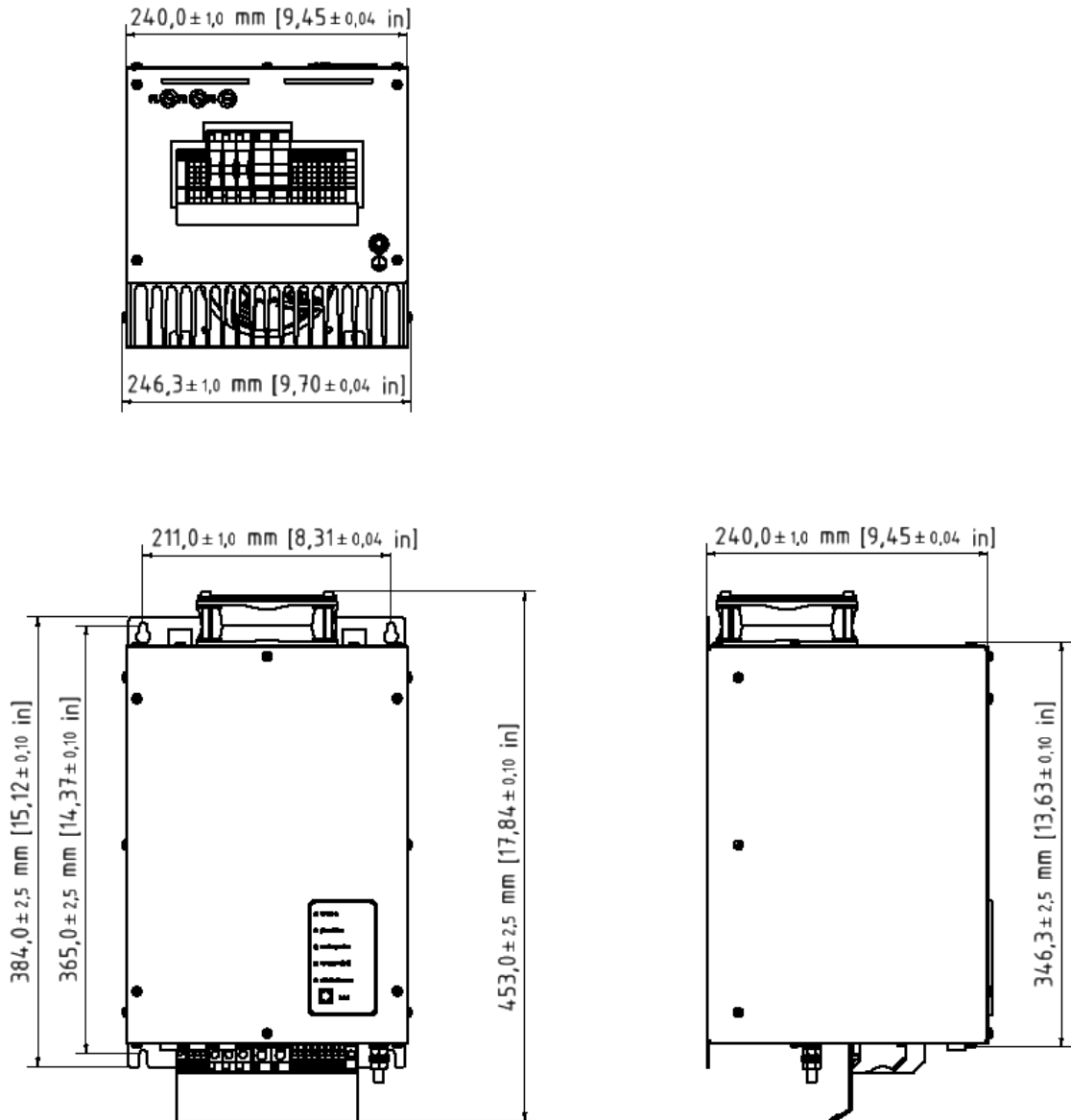

## 2. Enclosure 0/341

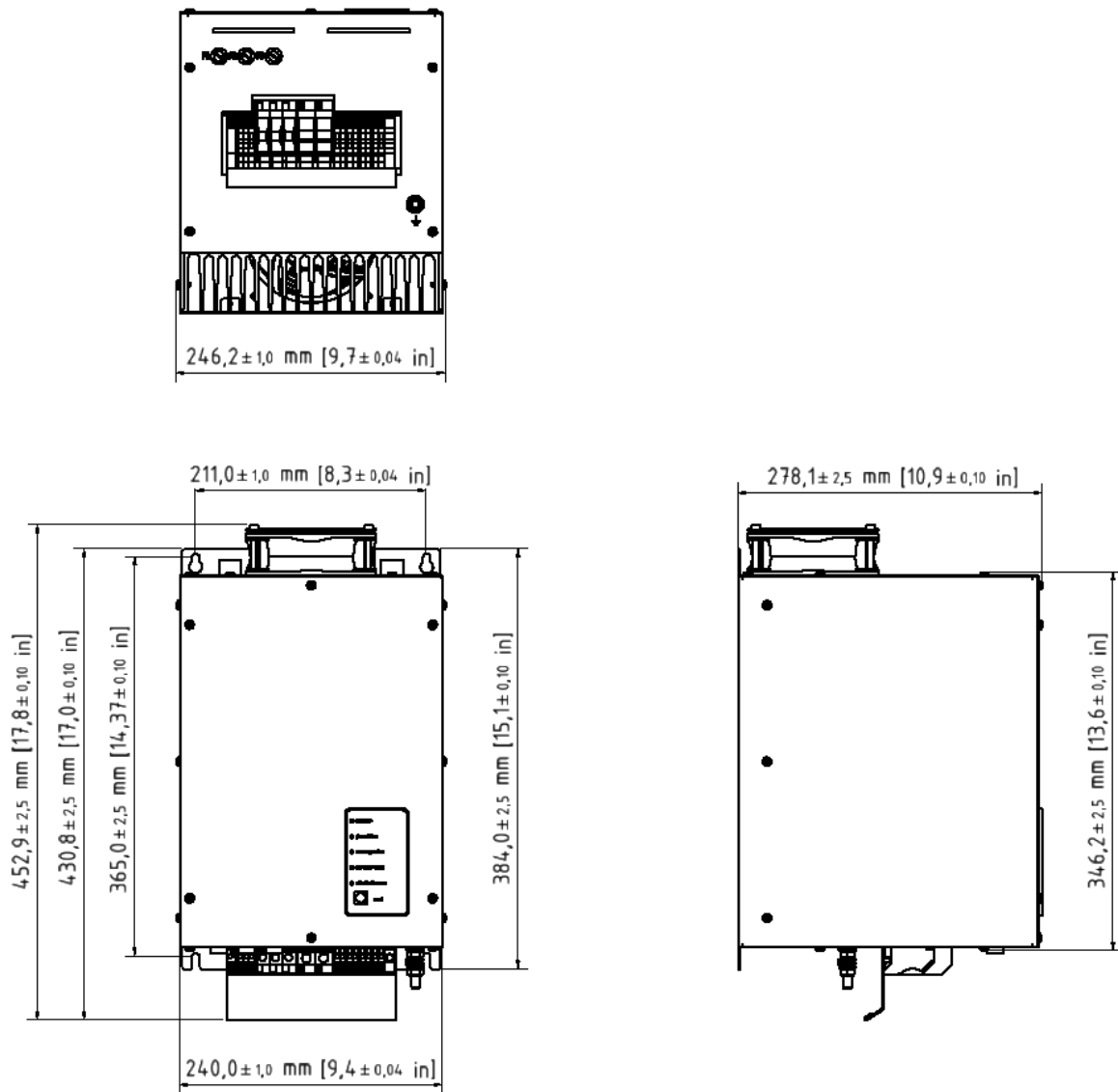

## Installation

### 3. Enclosure 0/400

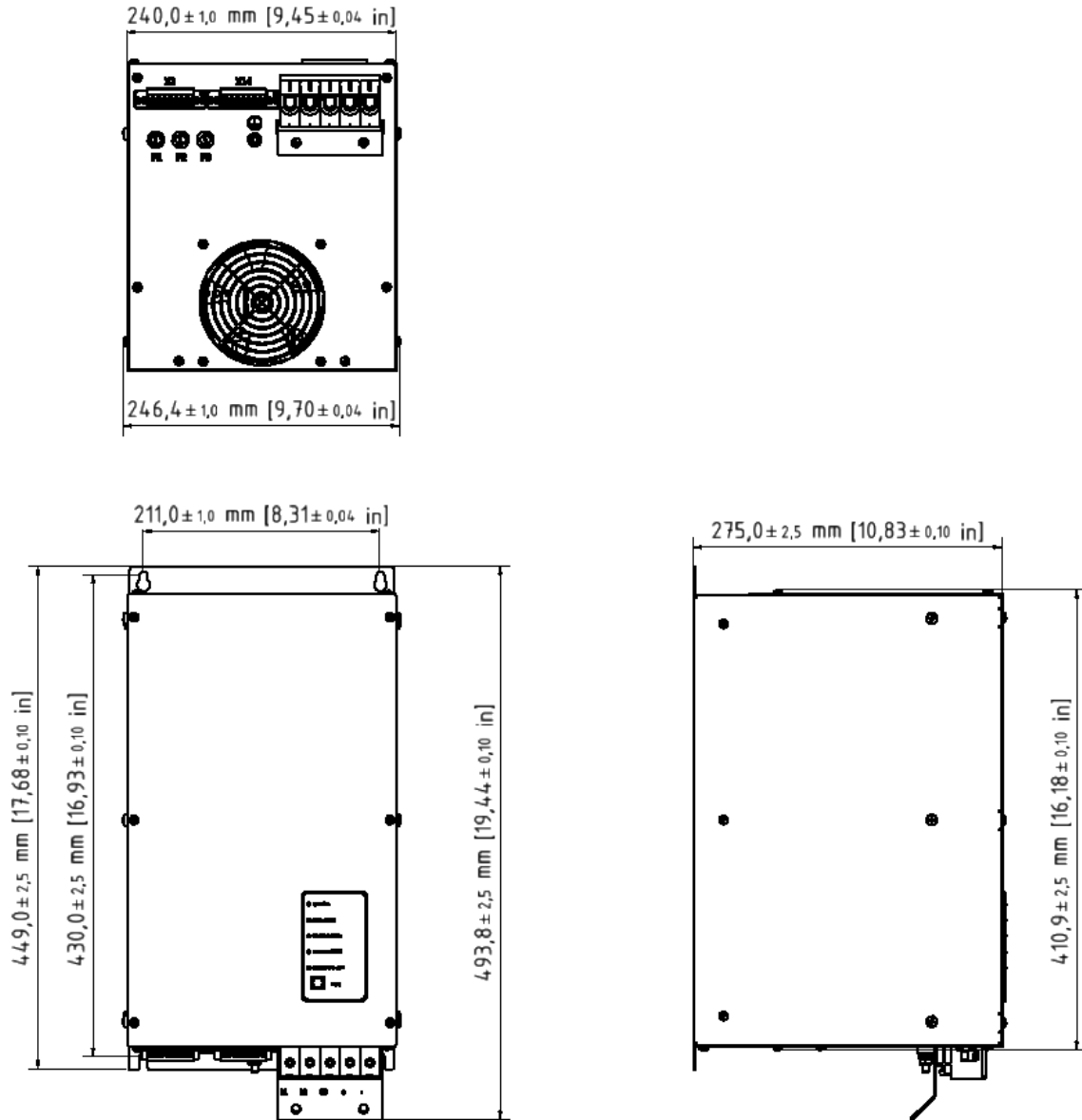

4. Enclosure 1/501

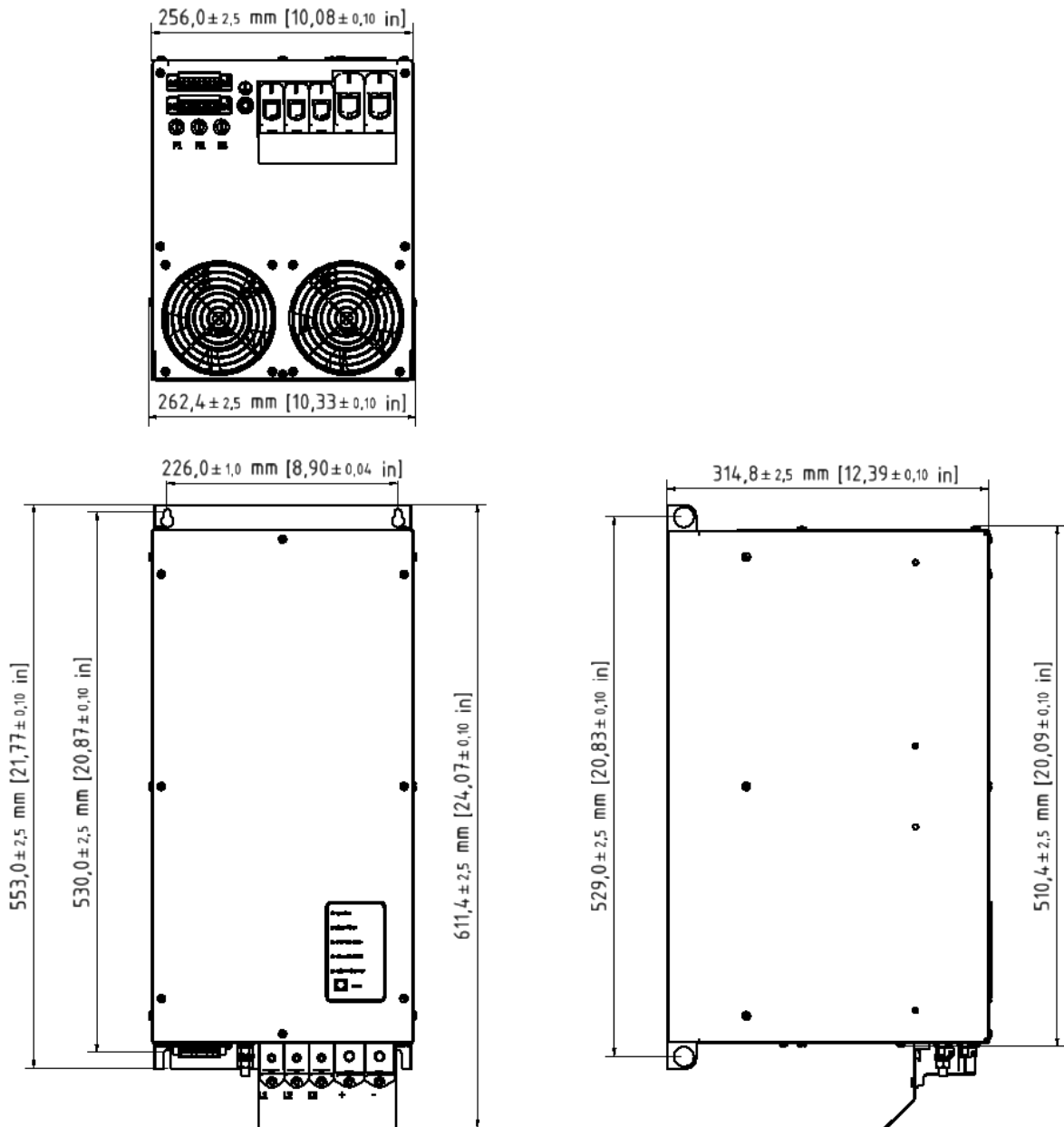



## Installation

### 5. Enclosure 2/701

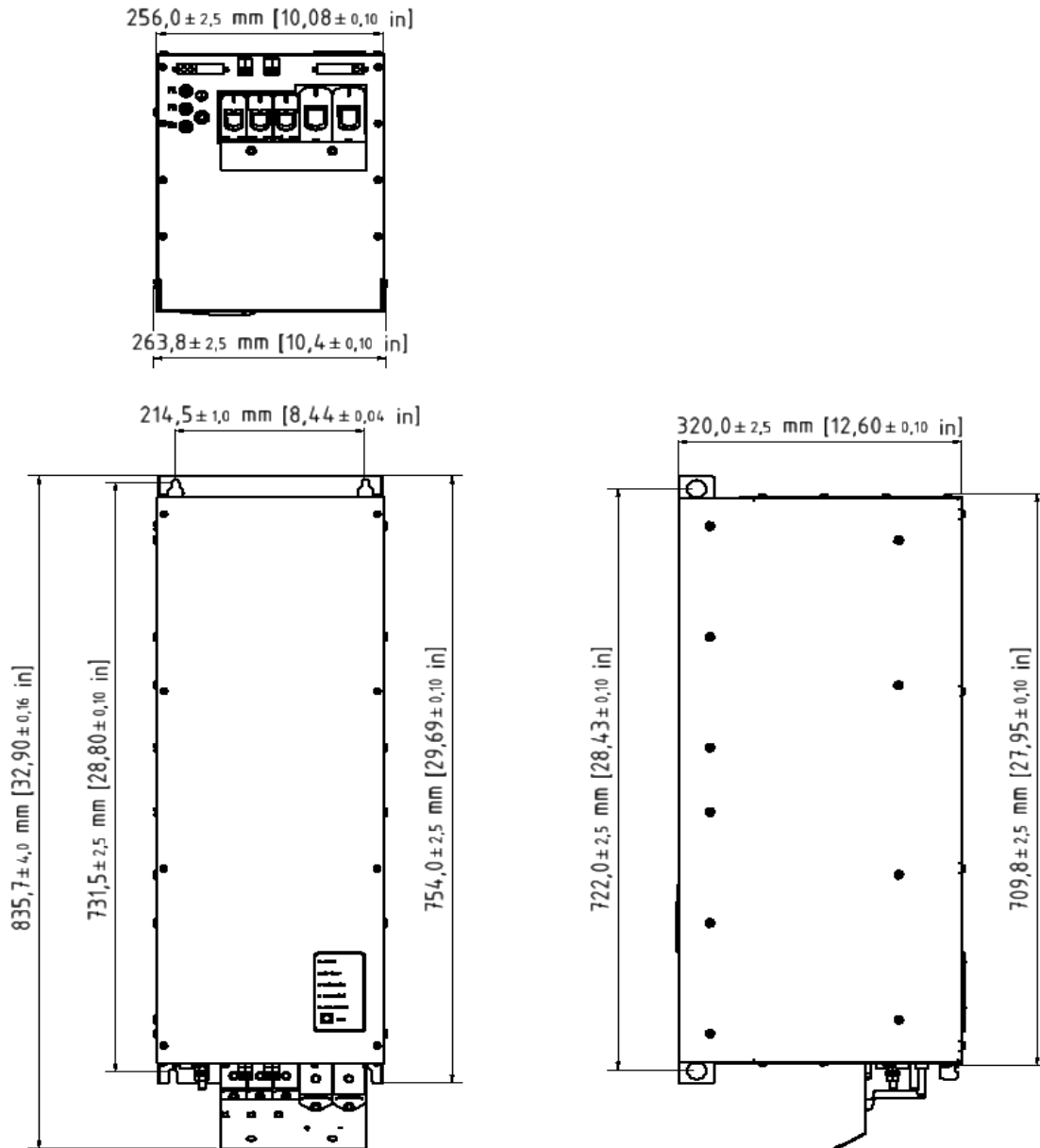

6. Enclosure 3/800

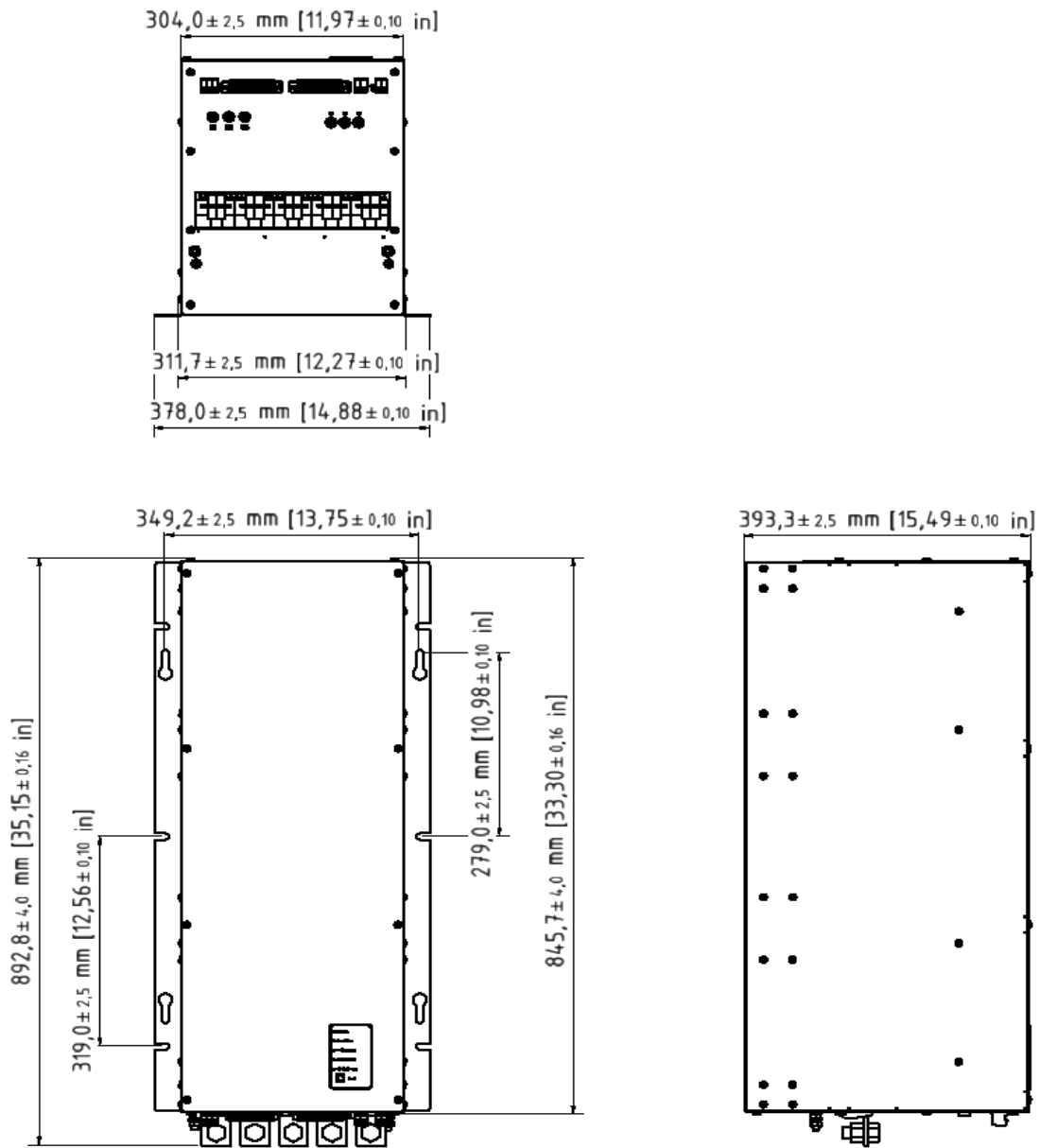

Installation

7. Enclosure 3/801

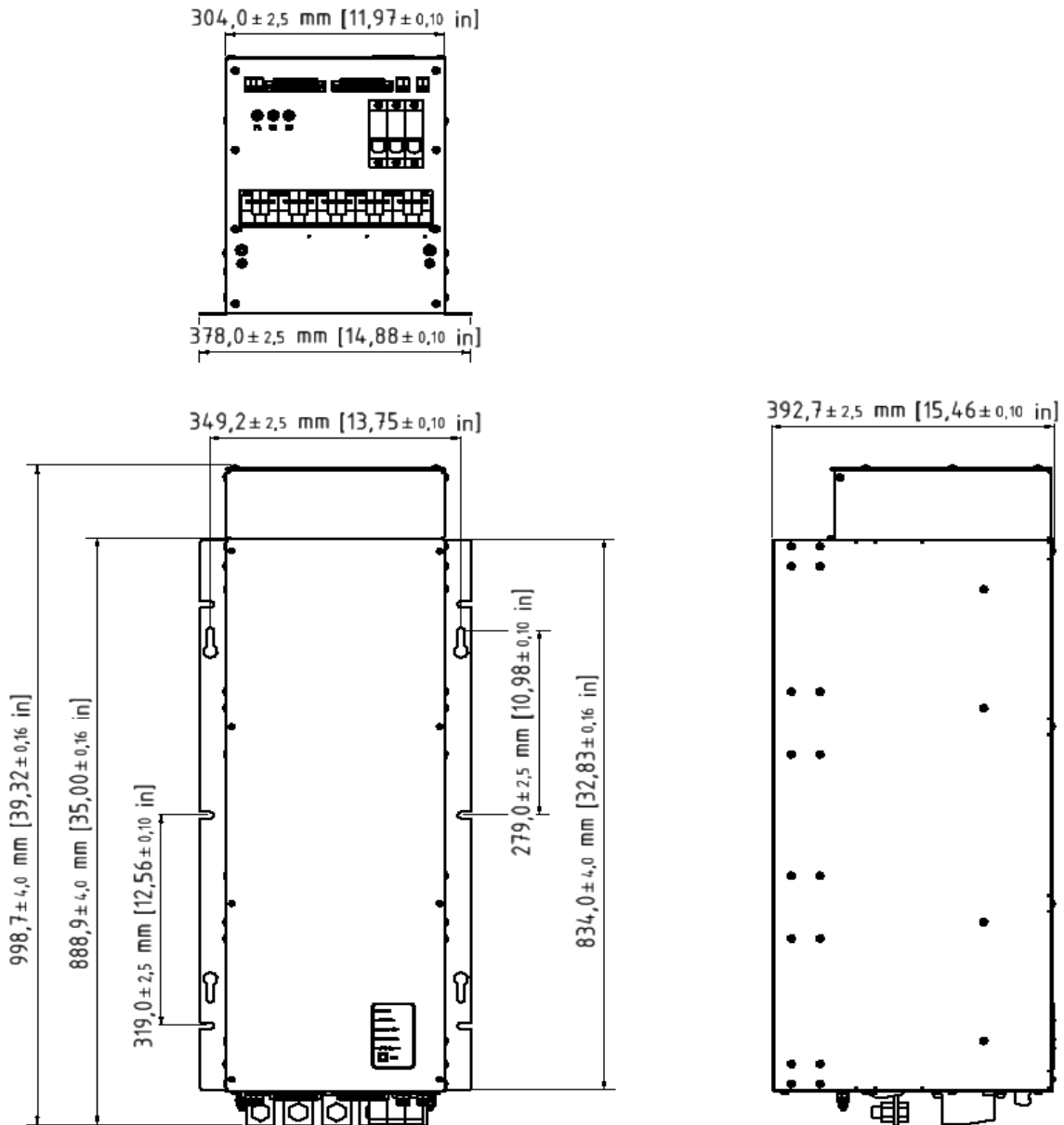

## 4.2.4 Dimensions RFI-filter

### 1. Diagram RFI-RA 01

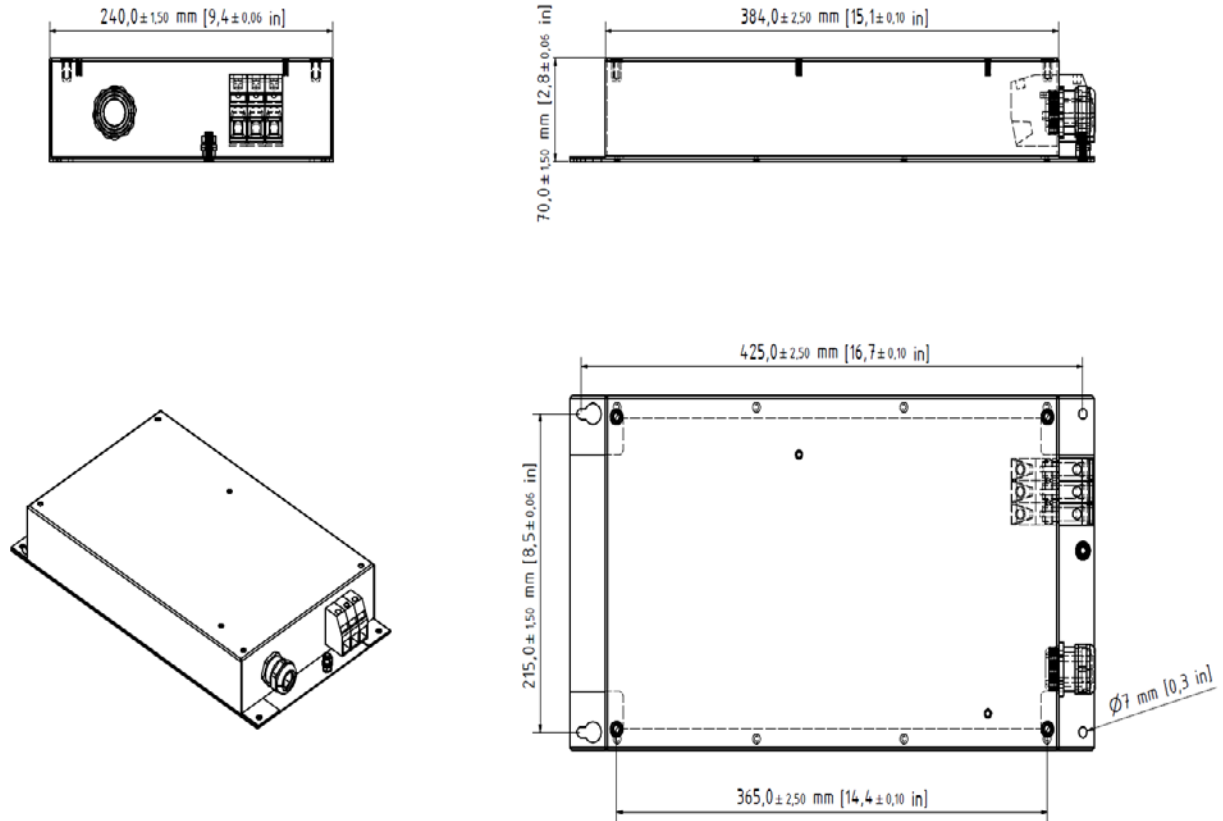

### 2. Diagram RFI-RA 02 and RFI-RA 13

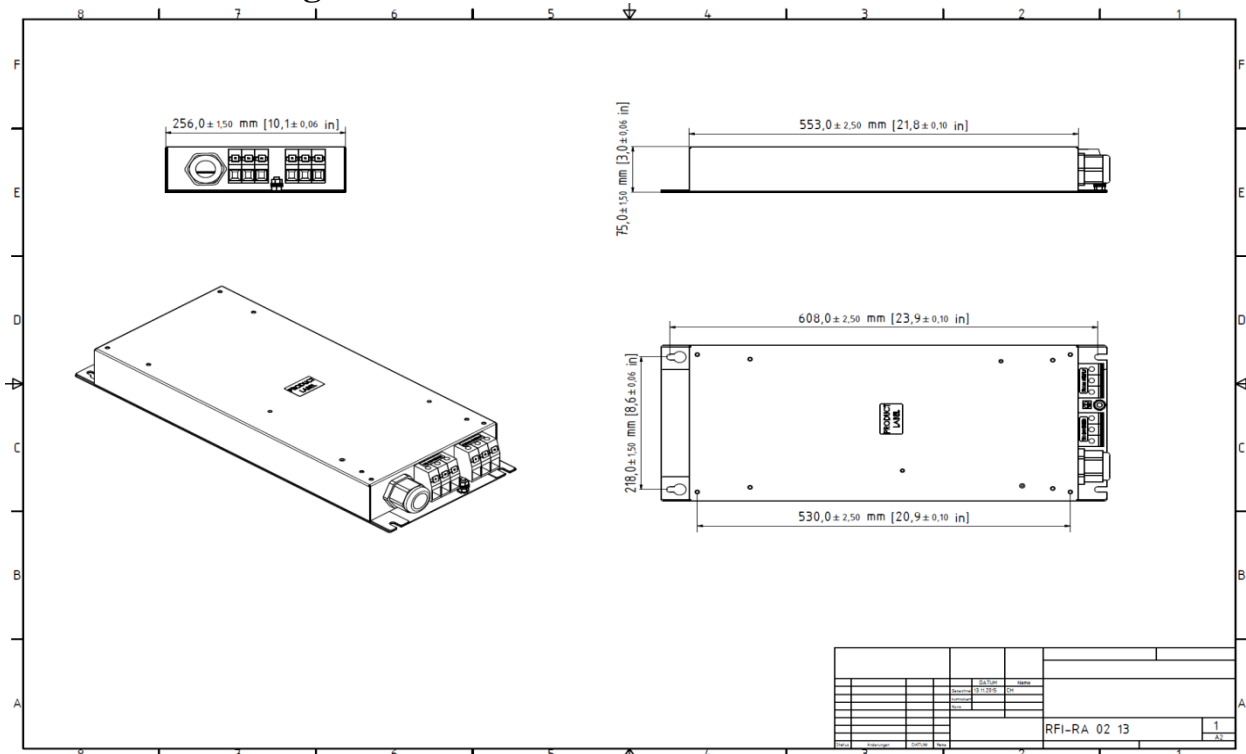

Installation

3. Diagram RFI-RA X5

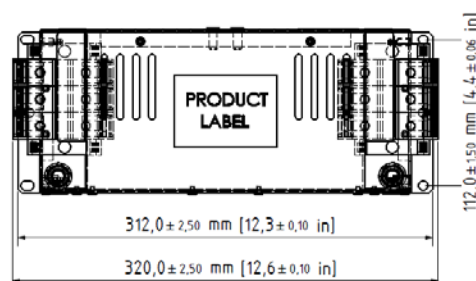
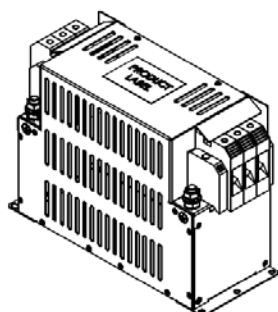
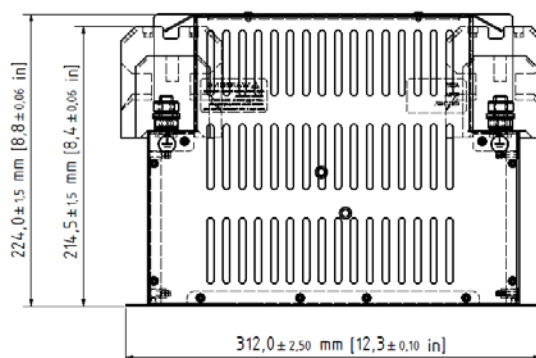
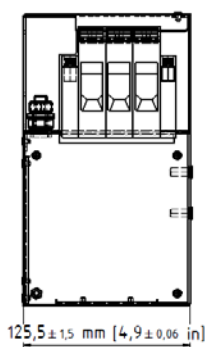

4. Diagram RFI-RA X6

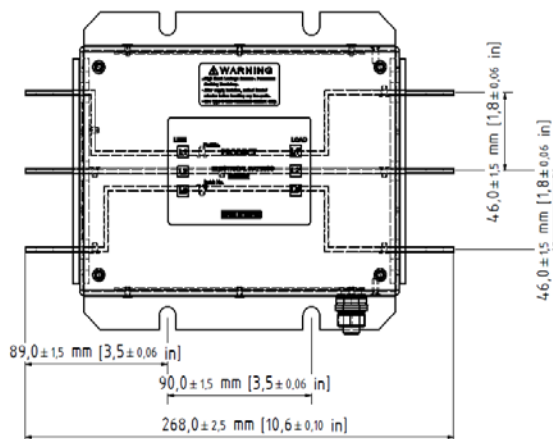
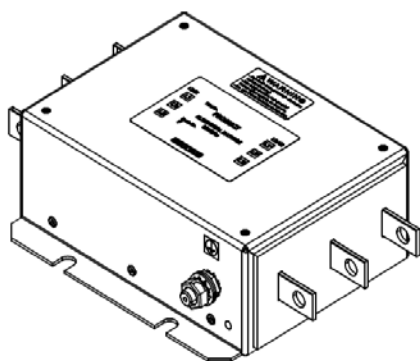
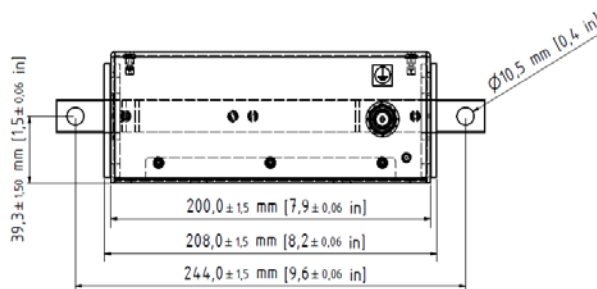
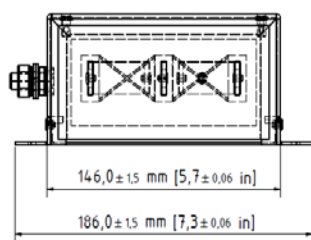

5. Diagram RFI-RA X7 and X8

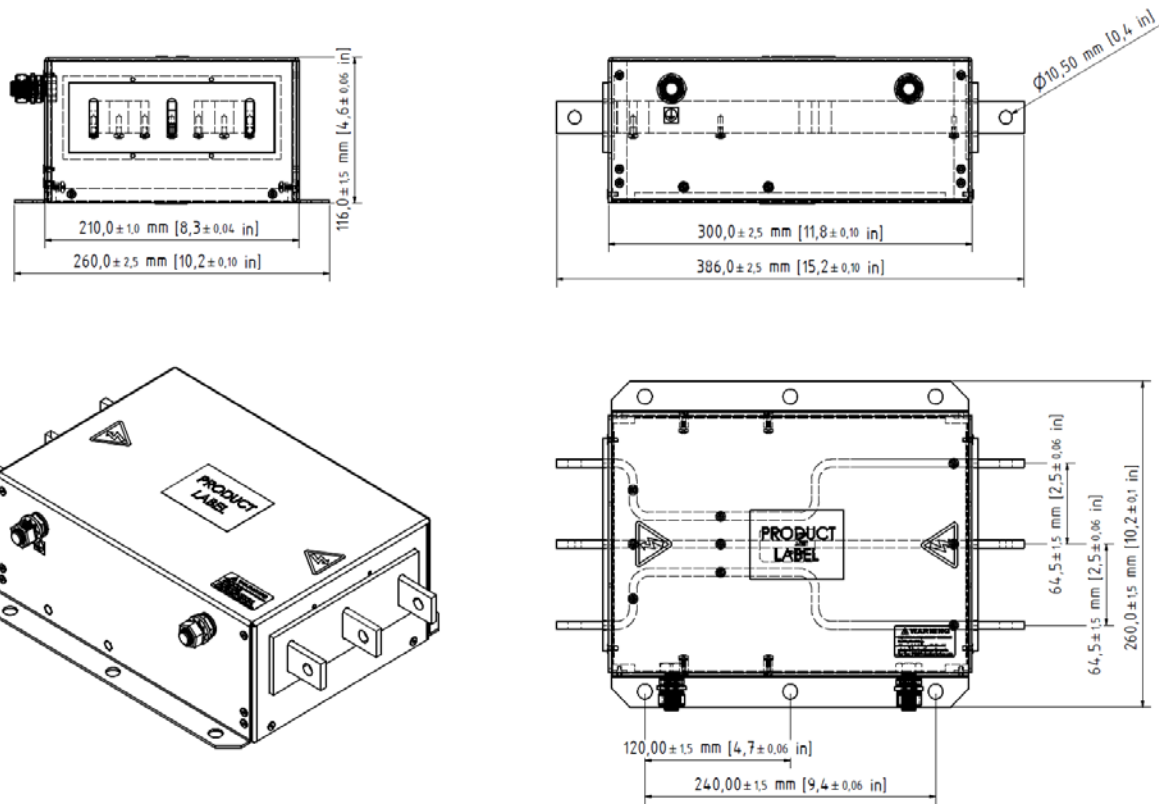

## Installation

### 4.2.5 Dimensions RHF-RA-filter

#### 1. Diagram X1

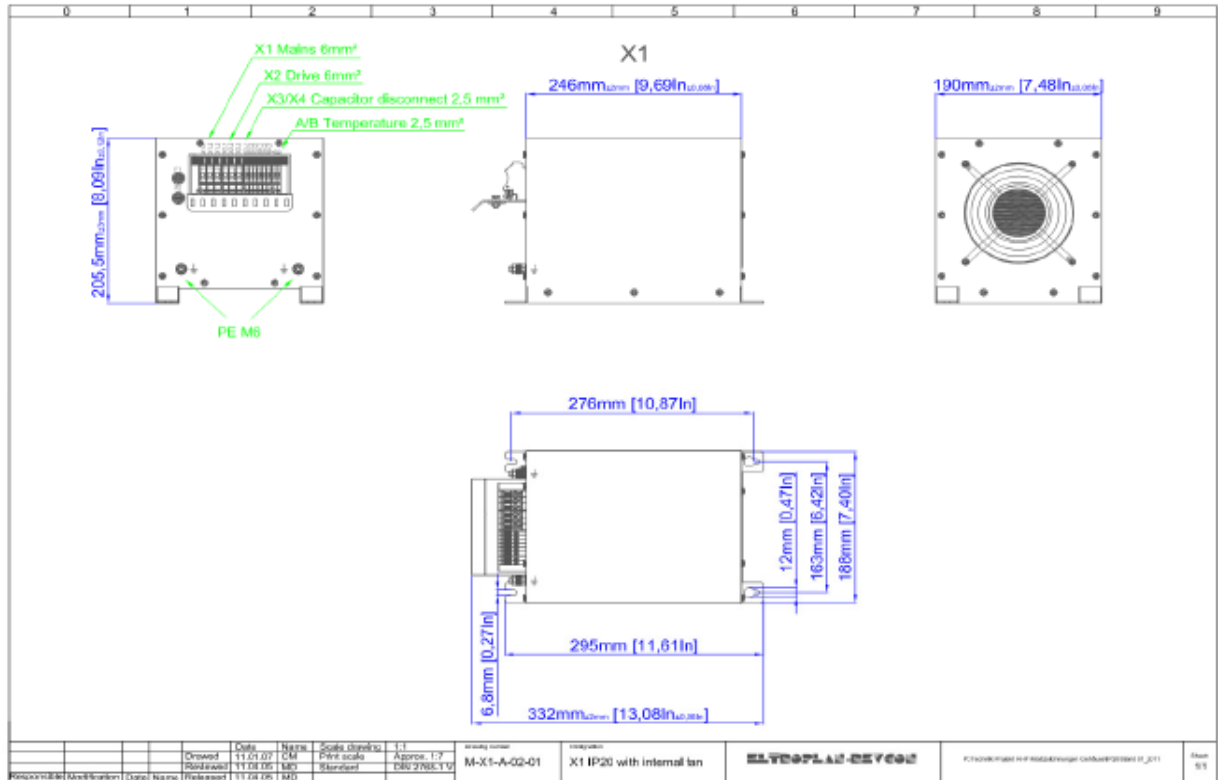

#### 2. Diagram X2

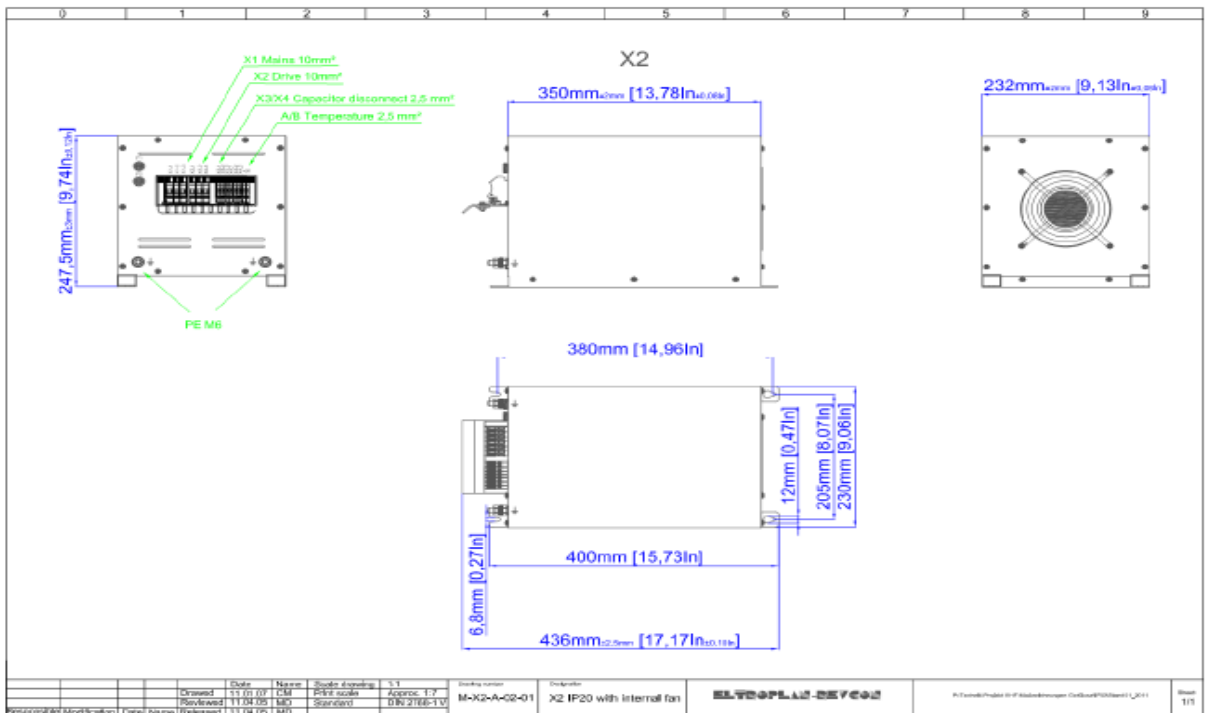

### 3. Diagram X3

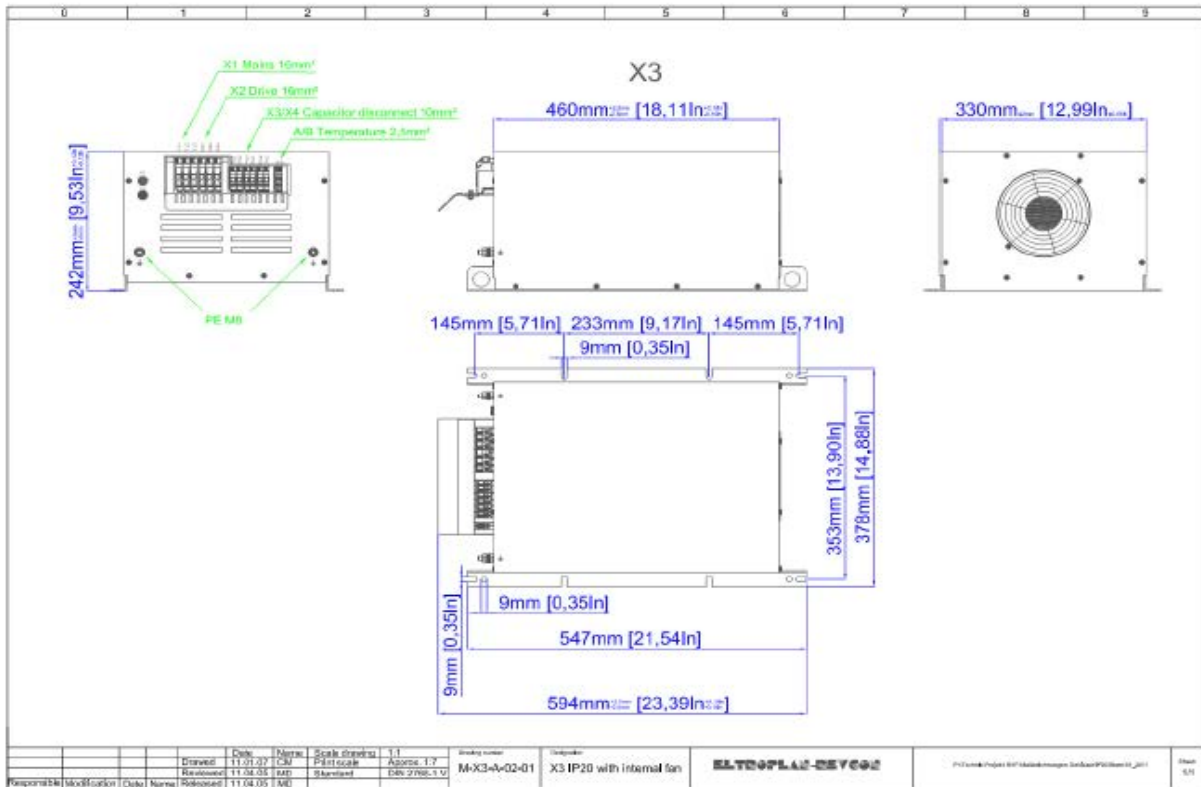

### 4. Diagram X4

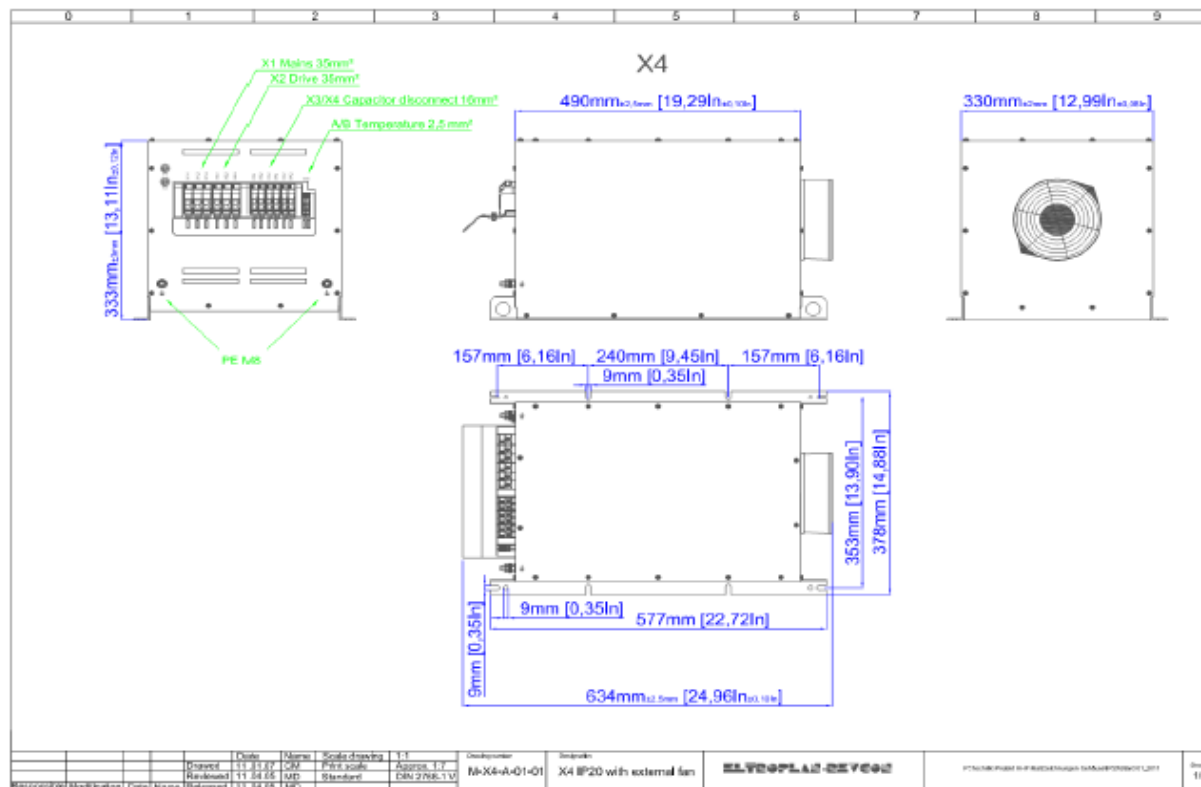



## Installation

### 5. Diagram X5

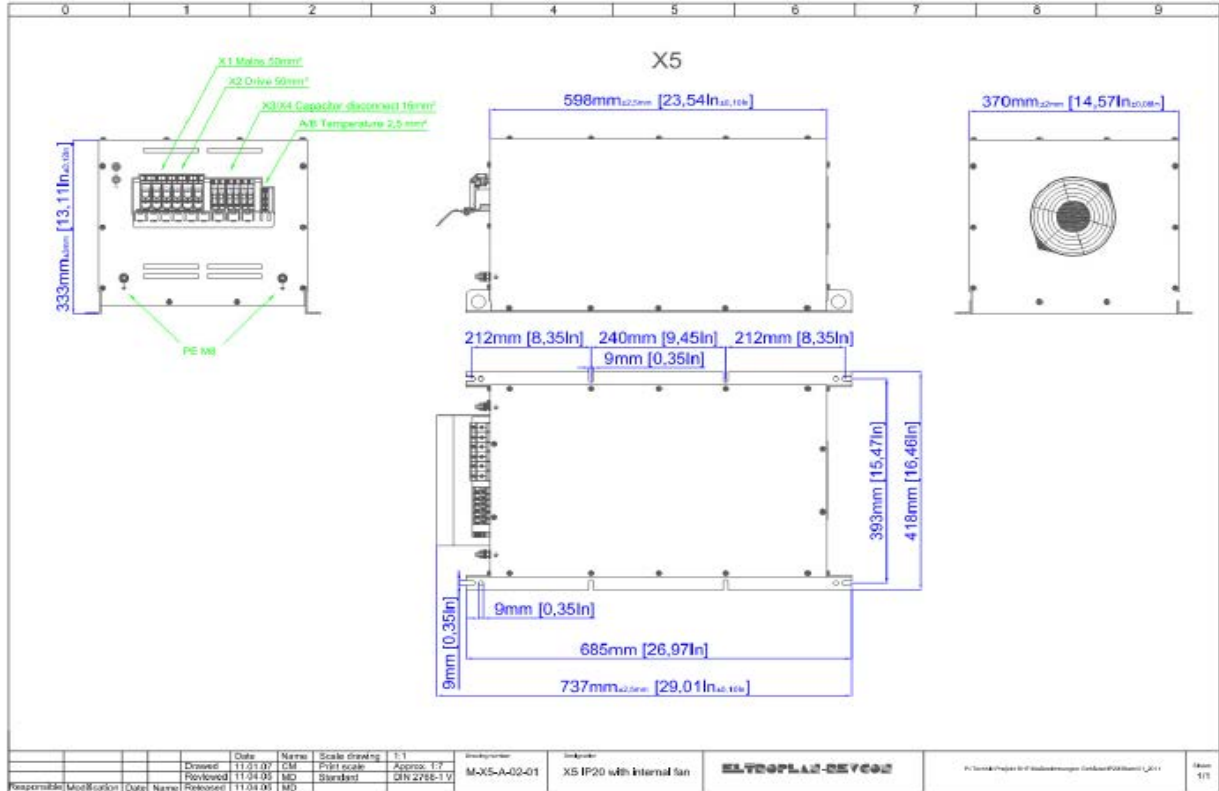

### 6. Diagram X5

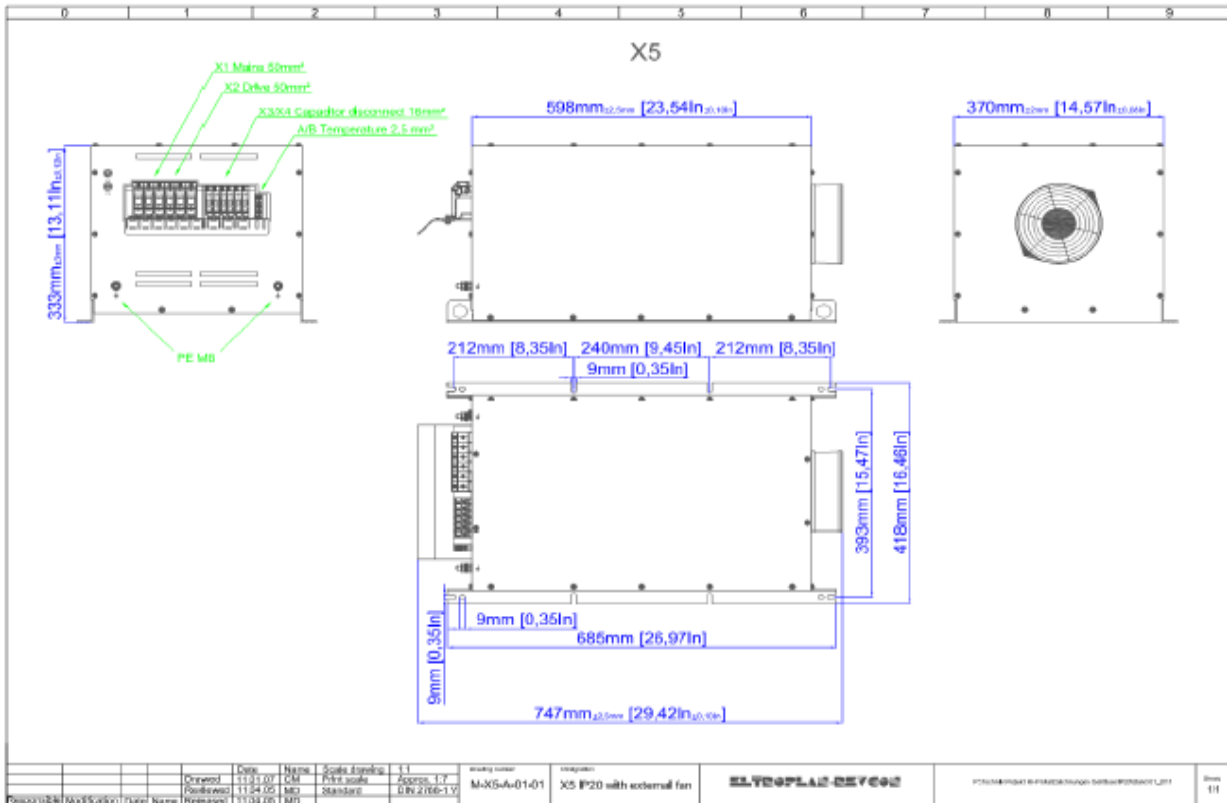

## 7. Diagram X6

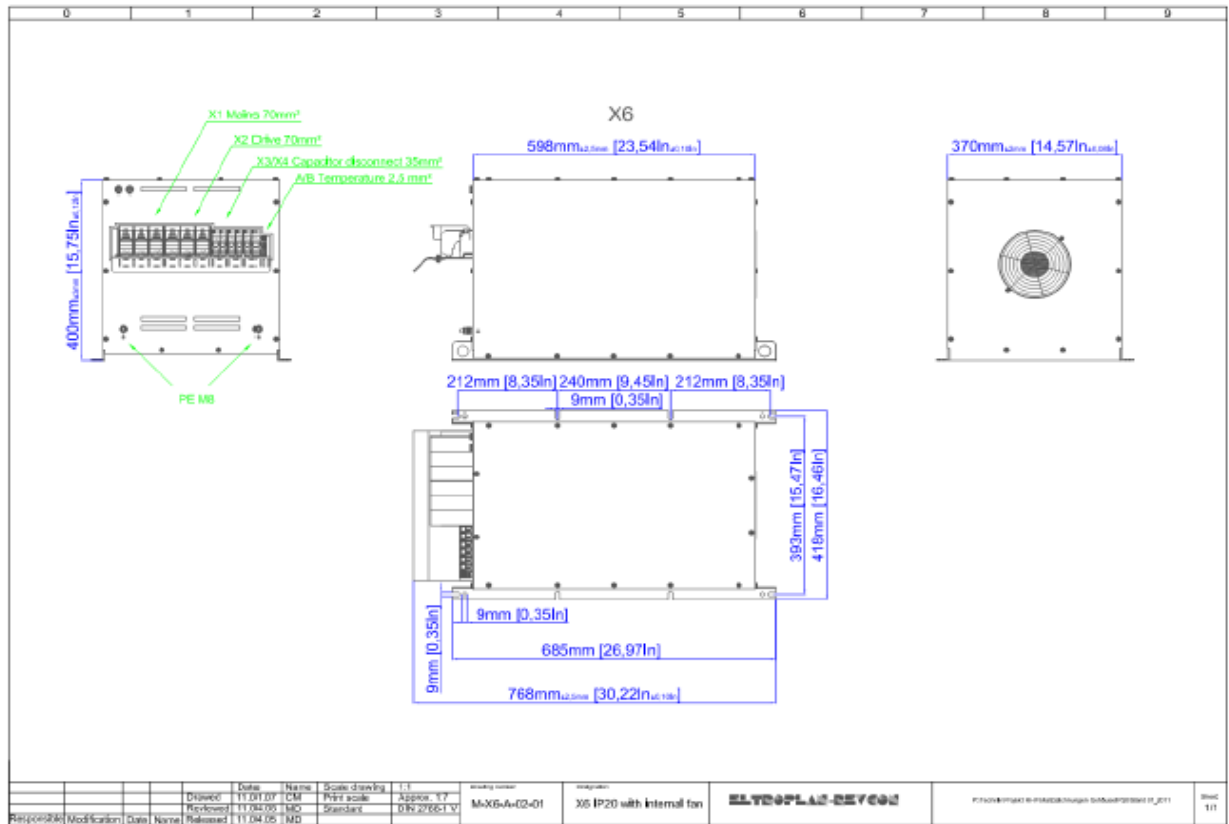

## 8. Diagram X7

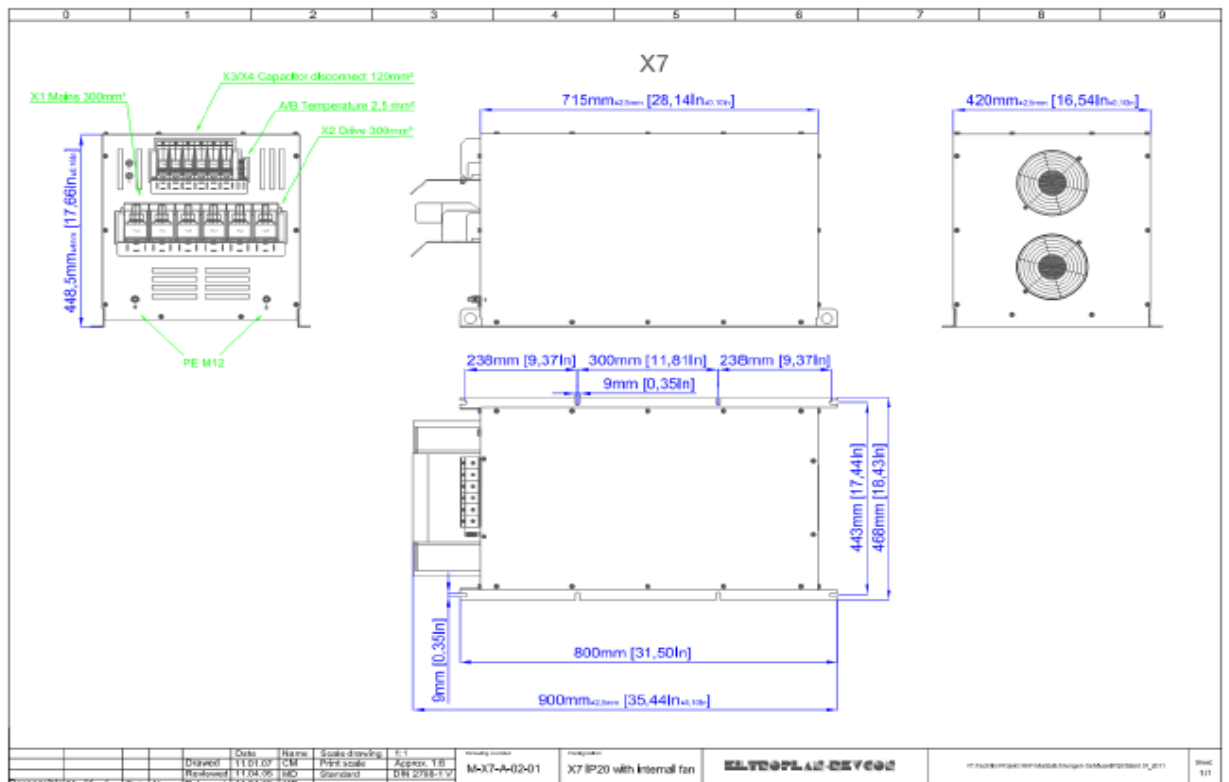

Installation

9. Diagram X8: Internal fan

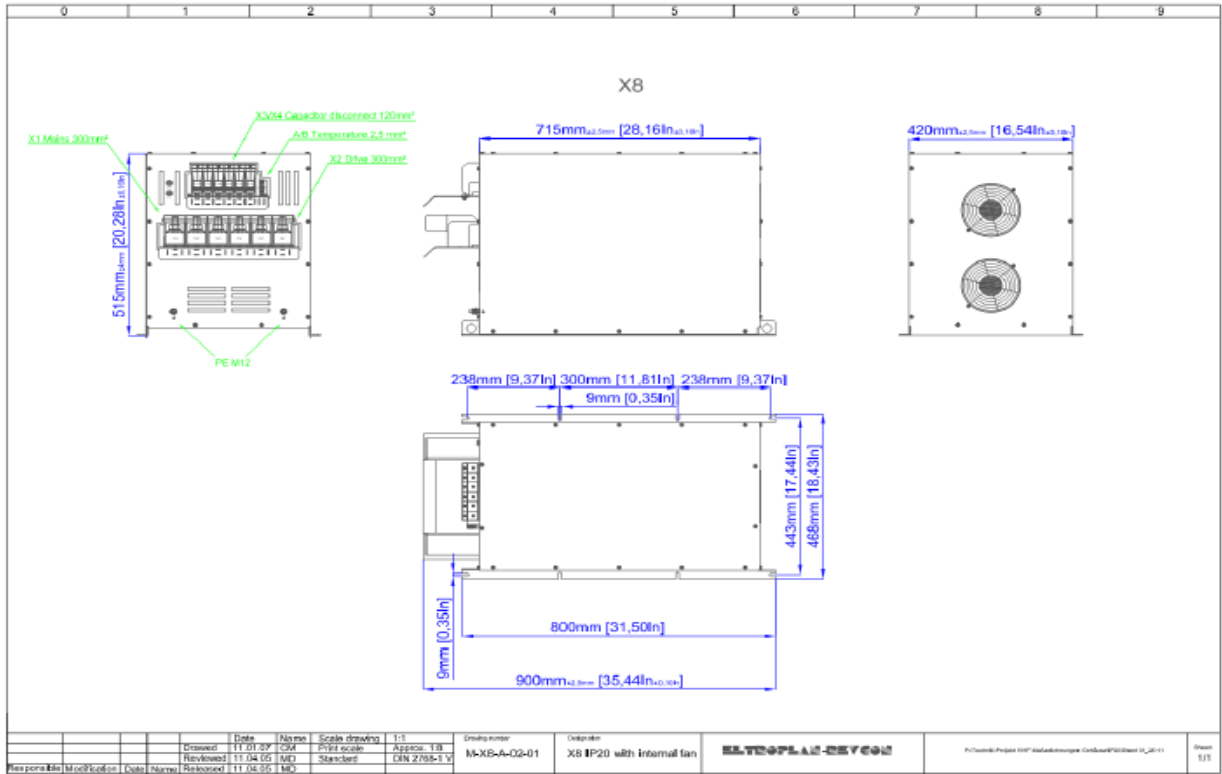

10. Diagram X8: external fan

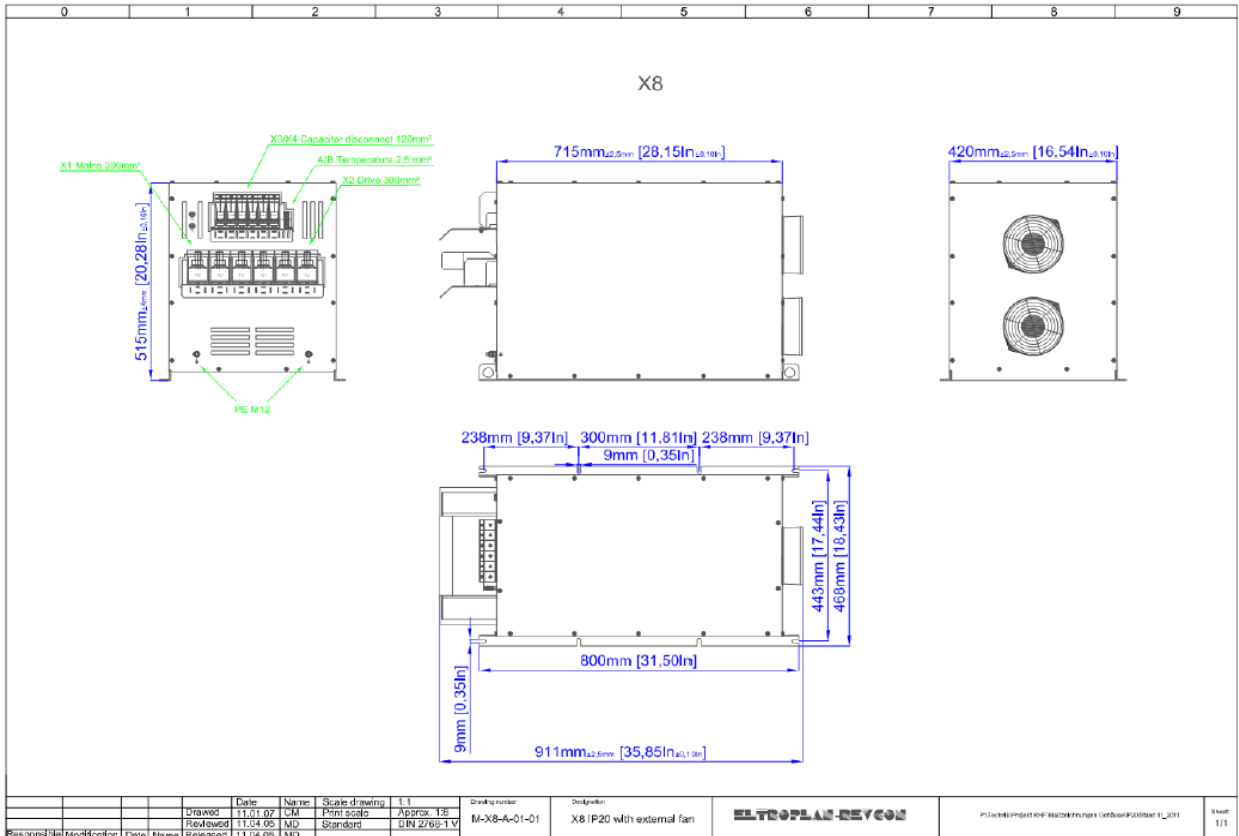

## 4.3 Electrical installation

### 4.3.1 Operator's safety

---

#### Danger!



After mains disconnection, the DC-bus terminals of the power feedback unit remain live for several minutes! The exact time, till this voltage has decreased to a not dangerous value is dependent on the used controller and has to run down before any service operations or similar activities are started.

The exact values have to be cross checked with the documentation of the controller.

---

Replace defective fuses by the regular types (chapter 3.5) only and without any live voltage.

### 4.3.2 Protection of the power feedback unit

---

#### Stop!

The power feedback units contain electrostatic sensitive devices (ESSD).



During working at the terminals the personnel has to observe the rules of the international standard IEC 747-1 chapter 9. Basically before starting the works the personnel has to free itself from electrostatic voltages:

Discharge yourself by touching the PE-screw of the housing or another grounded surface in the cabinet.

---

## Electrical Installation

### 4.3.3 Mains types / Mains characteristics

**Danger!**



Observe the restrictions in accordance to the respective mains type!

If you want to run power feedback units at mains types, which are not listed in the table below please consult our technicians.

VDE conformal mains type	Operation of the power feedback unit	Remark
With grounded star point	<b>Allowed</b>	Observe the technical data of the unit
With isolated star point	<b>Allowed</b>	The voltage between L <sub>1</sub> -L <sub>3</sub> and PE must not be higher than the nominal voltage
With grounded active wire	<b>Allowed</b>	The voltage between L <sub>1</sub> -L <sub>3</sub> and PE must not be higher than the nominal voltage

Table 4.4.3.1

### 4.3.4 Specifications of the used wires

- The used wires have to be compliant with the specifications on site ( e.g. UL or UL-c)
- The regulations about the minimum cross section of PE-wires have to be observed!
- The effectiveness of a screened wire is dependent on
  - a good screen connection
  - a low screening impedance:
    - Use screens tin- or nickel-plated copper screens only!
  - the swamp factor of the screen mesh:
    - at least 70% to 80% with a swamp angle of 90°
- Protect the mains wires of the power feedback unit with the provided wire protection fuses.

## 4.4 Connection

The supply line must be connected at the lead-through terminal at the bottom side of the enclosure.

### 4.4.1 Power connection

#### Fusing (also refer to chapter 3.5)

- The specifications of chapter 3.5 (fuses and wire cross sections) are recommendations and refer to the operation
  - in cabinets and machines
  - installation in cable ducts
  - maximum ambient temperature +40°C.
- When choosing the cross section of the wire the voltage drop under load should be considered (refer to chapter 3.4)
- Protection of the power feedback unit at mains side (L1, L2, and L3):
  - by commercial semiconductor fuses
  - fuses have to be compliant with the relevant standards on site
  - rated voltage of the fuses have to be compliant with the voltage on site
- Protection of the power feedback unit at DC side (+UG, -UG):
  - by commercial semiconductor fuses
  - fuses have to be compliant with the relevant standards on site
  - rated voltage of the fuses have to be compliant with the voltage on site

**The erector/user of the plant bears the responsibility for the observance of further relevant standards (e.g.: VDE 0113, VDE 0289 etc.).**

---

## Electrical Installation

---

### Connection

- All connections should be as short and low-impedance as possible.
- For the observance of the EMC-guideline (in accordance to actual standards like VDE 0160 and EN 50178) screened wires have to be used.
- Connect the mains supply wires at the terminals L1, L2, L3 (at the mains choke) of the power feedback unit. Only three phase connection is allowed.
- A defined phase sequence (clockwise rotation field) must be observed at the main circuit connection of the power unit. The power feedback unit is equipped with a phase-sequence control unit. In case of an incorrect rotation field an error message is displayed via LED as follows: "rotation field failure" or "phase failure". In this case two phases, connected to the power unit, have to be exchanged.
- Connect the earthing wire of the supply cables to the earthing screw of the power feedback unit.
- The wires for the DC-bus coupling between controller and power feedback unit have to be connected to the DC terminals. It is absolutely necessary to observe the correct polarity.



#### **Danger!**

An interchanging of + (PLUS) and – (MINUS) avoids the correct function of the power feedback unit.

---



#### **Danger!**

It is in no case allowed to pre-connect not current compensated direct inductances!

---

4.4.1.1 Wiring schematic REVCON RLD E0

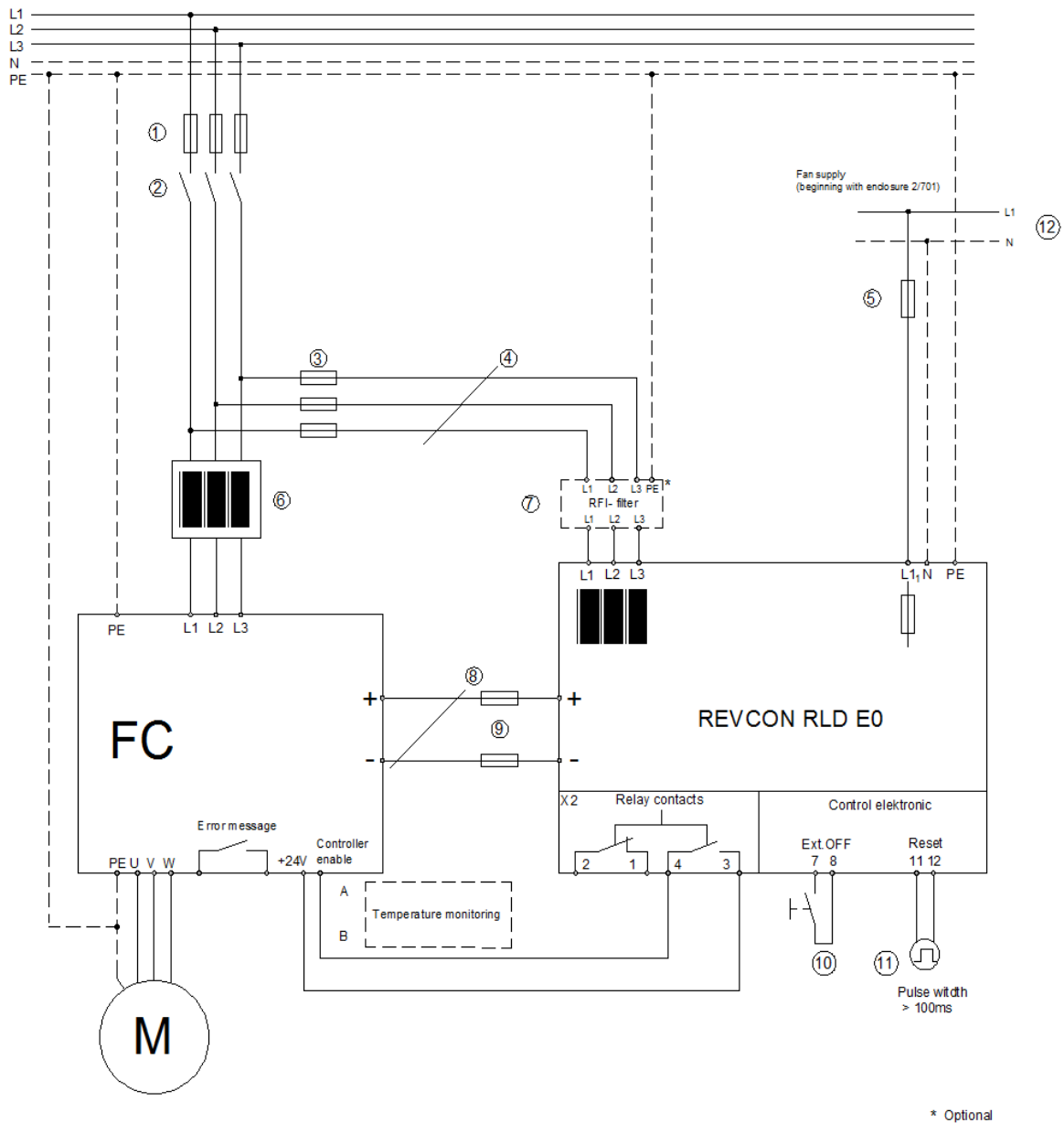

Figure 4.4.1.1: Wiring schematic of the power feedback unit REVCON® RLD E0 and one or more controller

**Note!**



This is a wiring example. Special features of an application (e.g. installation of a PLC) may require modifications of the wiring of the terminals X2.1 ... X2.12.

**Danger!**



\* It is in no case allowed to pre-connect not current compensated direct inductances!



---

## Electrical Installation

---

### Legend for figure 4.4.1.1 (REVCON® RLD E0)

1. Fusing in accordance with controller manual.
  2. It is not allowed to connect any other devices except the frequency inverter and the power feedback unit behind the main magnetic switch.
- 

#### **Danger!**



If this is not observed, you take the risk that, in the case of switching off the mains during feed-back the power, the voltage in that sector may rise up to a dangerous level. This may destroy the connected devices and perhaps also the inverter and/or the power feedback unit. To avoid such situation, the power feedback unit is equipped with an overvoltage switch off, but nevertheless this hint should be observed!

---

3. Fusing in accordance with power feedback unit manual. This may be left out, if at position 1 semiconductor fuses or full range fuses are used and if after 1 the cross section of the wires is not reduced.
4. Cross section in accordance with the relevant VDE-rules.
5. Beginning with enclosure 2: Fusing (Supply, <2A current input) in accordance with DIN VDE 0298 or short circuit proof wiring.
6. Choking inductance in accordance with controller manual (possibly not applicable, if already installed inside the controller).
7. RFI filter, optional:  
At RFI-filter installation size RFI-RA01 is the connection to the power feedback module realized by a PG-screw connection. This connection of the RFI-filter must occur phase correct over the terminals -From Supply-. The terminals -To Inverter- must be open.
8. At these terminals one or more controllers (even with different power ratings) may be attached, like it shown in figure 4.5.1. Even if several controllers are attached, the wires have to be as **short and low impedance** as possible!
9. DC fuses: The power feedback is not equipped with DC fuses.
10. The possibility of an external „OFF“ by the terminals 7 and 8:  
These terminals may be used for an external **OFF**-signal (NOC, short time contact) to stop the power feedback unit.
11. The „ON“ or „RESET“ signal may be initiated via terminals 11 and 12:  
Terminals 11 and 12: Positive pulse (12-24 V DC); practicable e.g. via PLC (terminal 11 +, terminal 12 -).
12. Fan supply: The power feedback modules beginning with enclosure 2/701 require the in the ordering code specified auxiliary voltage (230V or 115V).

4.4.1.2 Wiring schematic REVCON RLD E0 with RHF-RA

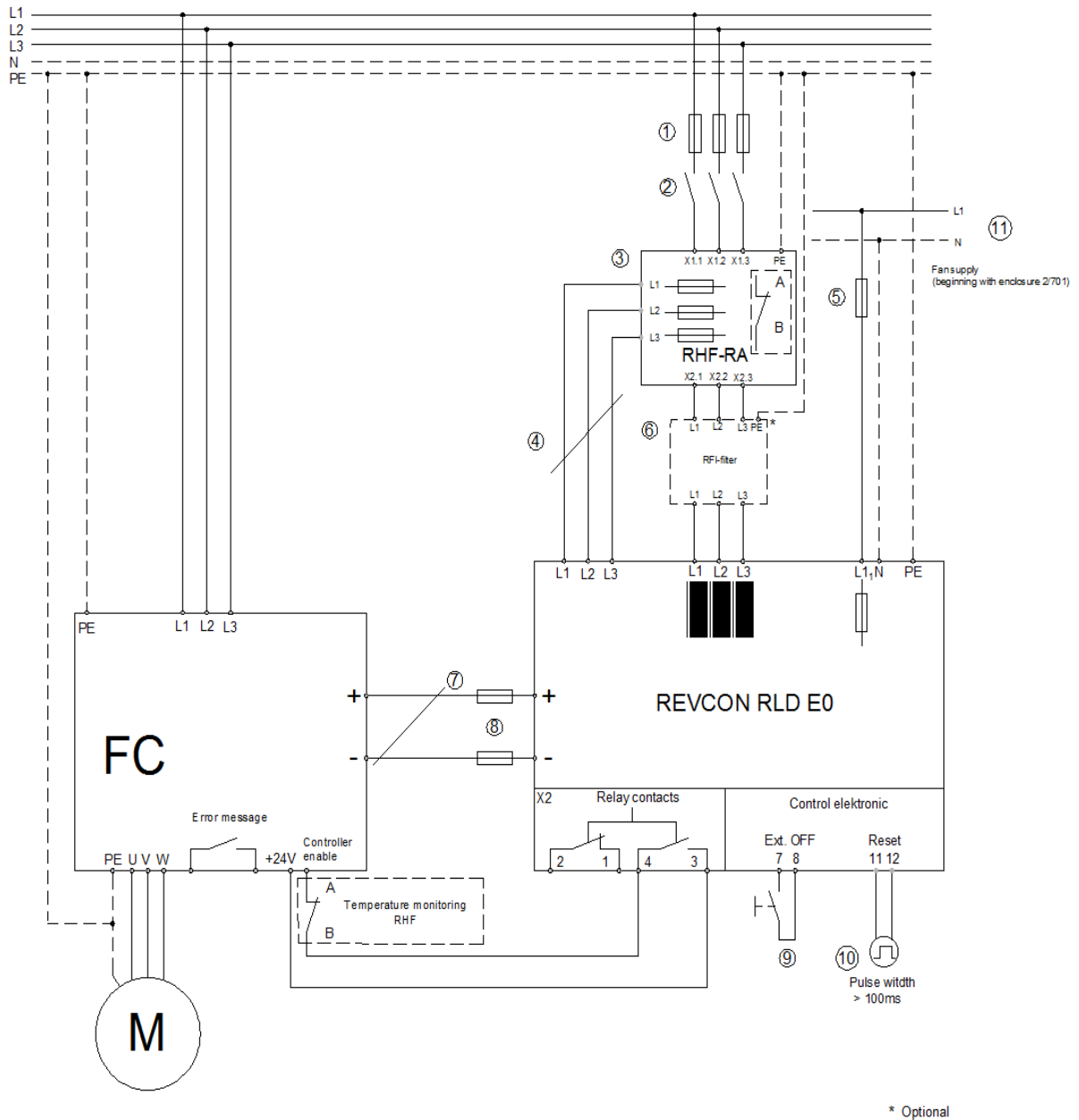

Figure 4.4.1.2: Wiring schematic of the power feedback unit REVCON® RLD E0 and one or more controller

**Note!**



This is a wiring example. Special features of an application (e.g. installation of a PLC) may require modifications of the wiring of the terminals X2.1 ... X2.12.

**Danger!**



\* It is in no case allowed to pre-connect not current compensated direct inductances!

---

## Electrical Installation

---

### Legend for figure 4.4.1.2 (REVCON® RLD E0 with RHF-RA)

1. Fusing in accordance with controller manual.
2. It is not allowed to connect any other devices except the frequency inverter and the power feedback unit behind the main magnetic switch.

---

#### **Danger!**



If this is not observed, you take the risk that, in the case of switching off the mains during feed-back the power, the voltage in that sector may rise up to a dangerous level. This may destroy the connected devices and perhaps also the inverter and/or the power feedback unit. To avoid such situation, the power feedback unit is equipped with an overvoltage switch off, but nevertheless this hint should be observed!

- 
3. RHF-RA module
  4. Cross section in accordance with the relevant VDE-rules.
  5. Beginning with enclosure 2: Fusing (Supply, <2A current input) in accordance with DIN VDE 0298 or short circuit proof wiring.
  6. RFI filter, optional:  
 At RFI-filter installation size RFI-RA01 is the connection to the power feedback module realized by a PG-screw connection. This connection of the RFI-filter must occur phase correct over the terminals -From Supply-. The terminals -To Inverter- must be open.
  7. At these terminals one or more controllers (even with different power ratings) may be attached, like it shown in figure 4.5.1. Even if several controllers are attached, the wires have to be as **short and low impedance** as possible!
  8. DC fuses: The power feedback is not equipped with DC fuses.
  9. The possibility of an external „OFF“ by the terminals 7 and 8:  
 These terminals may be used for an external **OFF**-signal (NOC, short time contact) to stop the power feedback unit.
  10. The „ON“ or „RESET“ signal may be initiated via terminals 11 and 12:  
 Terminals 11 and 12: Positive pulse (12-24 V DC); practicable e.g. via PLC (terminal 11 +, terminal 12 -).
  11. Fan supply: The power feedback modules beginning with enclosure 2/701 require the in the ordering code specified auxiliary voltage (230V or 115V).

4.4.1.3 Wiring schematic REVCON RLD E0 and FC with RHF-RA

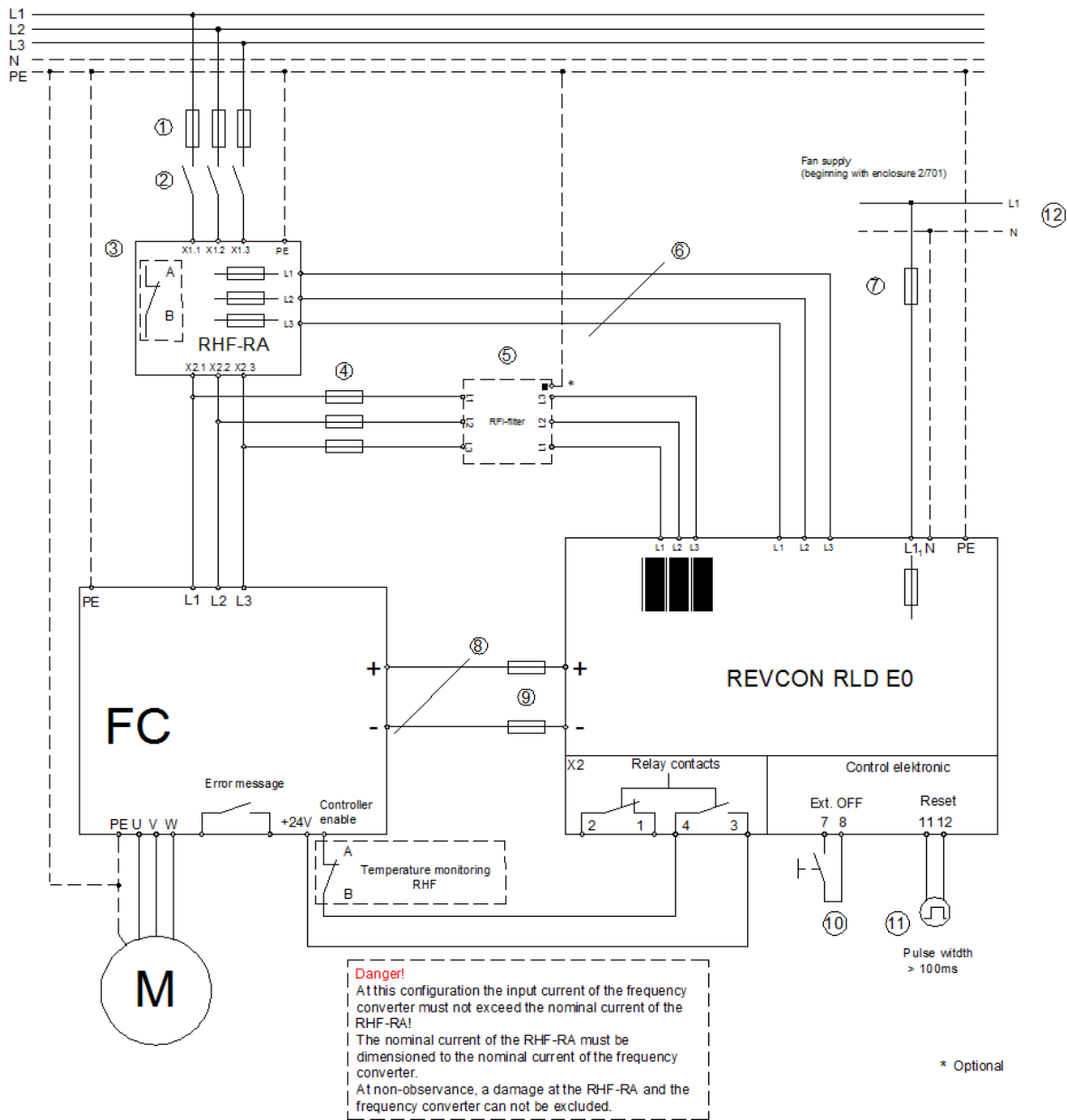

Figure 4.4.1.3: Wiring schematic of the power feedback unit REVCON® RLD E0 and one or more controller

**Note!**



This is a wiring example. Special features of an application (e.g. installation of a PLC) may require modifications of the wiring of the terminals X2.1 ... X2.12.

**Danger!**



\* It is in no case allowed to pre-connect not current compensated direct inductances!

---

## Electrical Installation

### Legend for figure 4.4.1.3 (REVCON<sup>®</sup> RLD E0 and FC with RHF-RA)

1. Fusing in accordance with controller manual.
2. It is not allowed to connect any other devices except the frequency inverter and the power feedback unit behind the main magnetic switch.

---

#### **Danger!**



If this is not observed, you take the risk that, in the case of switching off the mains during feed-back the power, the voltage in that sector may rise up to a dangerous level. This may destroy the connected devices and perhaps also the inverter and/or the power feedback unit. To avoid such situation, the power feedback unit is equipped with an overvoltage switch off, but nevertheless this hint should be observed!

- 
3. RHF-RA module
  4. Fusing in accordance with power feedback unit manual. This may be left out, if at position 1 semiconductor fuses or full range fuses are used and if after 1 the cross section of the wires is not reduced.
  5. RFI filter, optional:  
 At RFI-filter installation size RFI-RA01 is the connection to the power feedback module realized by a PG-screw connection. This connection of the RFI-filter must occur phase correct over the terminals -From Supply-. The terminals -To Inverter- must be open.
  6. Cross section in accordance with the relevant VDE-rules.
  7. Beginning with enclosure 2: Fusing (Supply, <2A current input) in accordance with DIN VDE 0298 or short circuit proof wiring.
  8. At these terminals one or more controllers (even with different power ratings) may be attached, like it shown in figure 4.5.1. Even if several controllers are attached, the wires have to be as **short and low impedance** as possible!
  9. DC fuses: The power feedback is not equipped with DC fuses.
  10. The possibility of an external „OFF“ by the terminals 7 and 8:  
 These terminals may be used for an external **OFF**-signal (NOC, short time contact) to stop the power feedback unit.
  11. The „ON“ or „RESET“ signal may be initiated via terminals 11 and 12:  
 Terminals 11 and 12: Positive pulse (12-24 V DC); practicable e.g. via PLC (terminal 11 +, terminal 12 -).
  12. Fan supply: The power feedback modules beginning with enclosure 2/701 require the in the ordering code specified auxiliary voltage (230V or 115V).

#### **4.4.2 Fan supply**

All power feedback modules to enclosure 2/701 are provided with an internal fan supply. The power feedback modules beginning with enclosure 2/701 require the in the ordering code specified auxiliary voltage (230V or 115V).

#### **4.4.3 Dimensions RFI-filter**

- Connect the control wires to the terminal row X2 at the control plate of the power feedback unit.
- Don't parallel control wires to interfering power wires.
- Connect the screening of the control wires with an as big as possible surface to the metal cable glands of the flange.

#### **4.4.4 Control functions**

The control terminal strip is placed on the control board and is indicated with X2. It is fitted with a plug-in device for easy handling in case of service.

The control board must always be designed for the respective main circuit voltage. Therefore the main circuit voltage (400V) must be declared with every order. This is also necessary for a possible exchange of the device.

From the control terminal strip the operating condition or rather the collective error can be connected to extern. There is also the possibility to execute the external reset or the switch-functions and to connect them with the controller or the PLC.

Electrical Installation

**Space diagram of the control board REV 1.4.X**

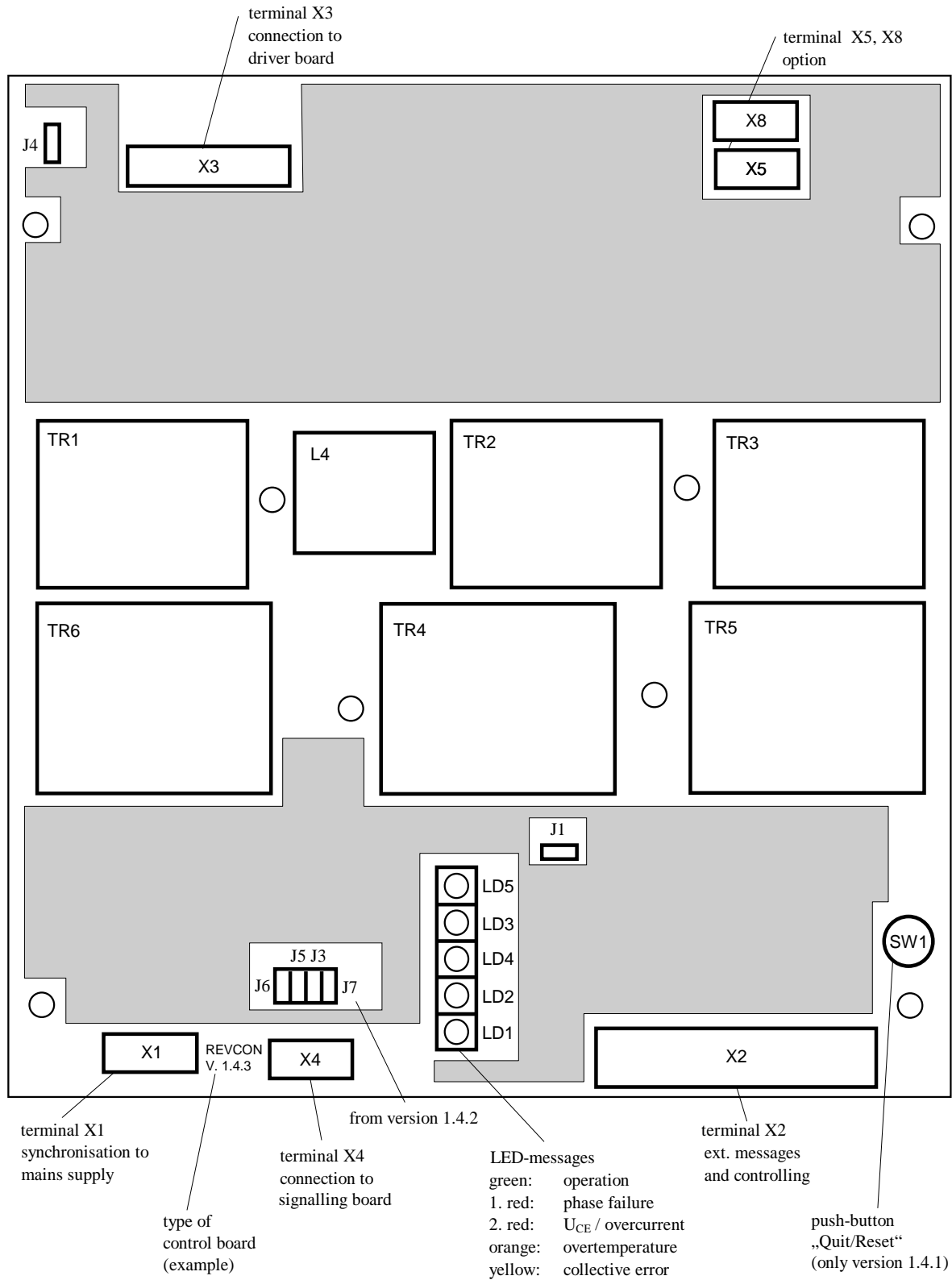

Figure 4.4.4.1

**Terminal usage:**

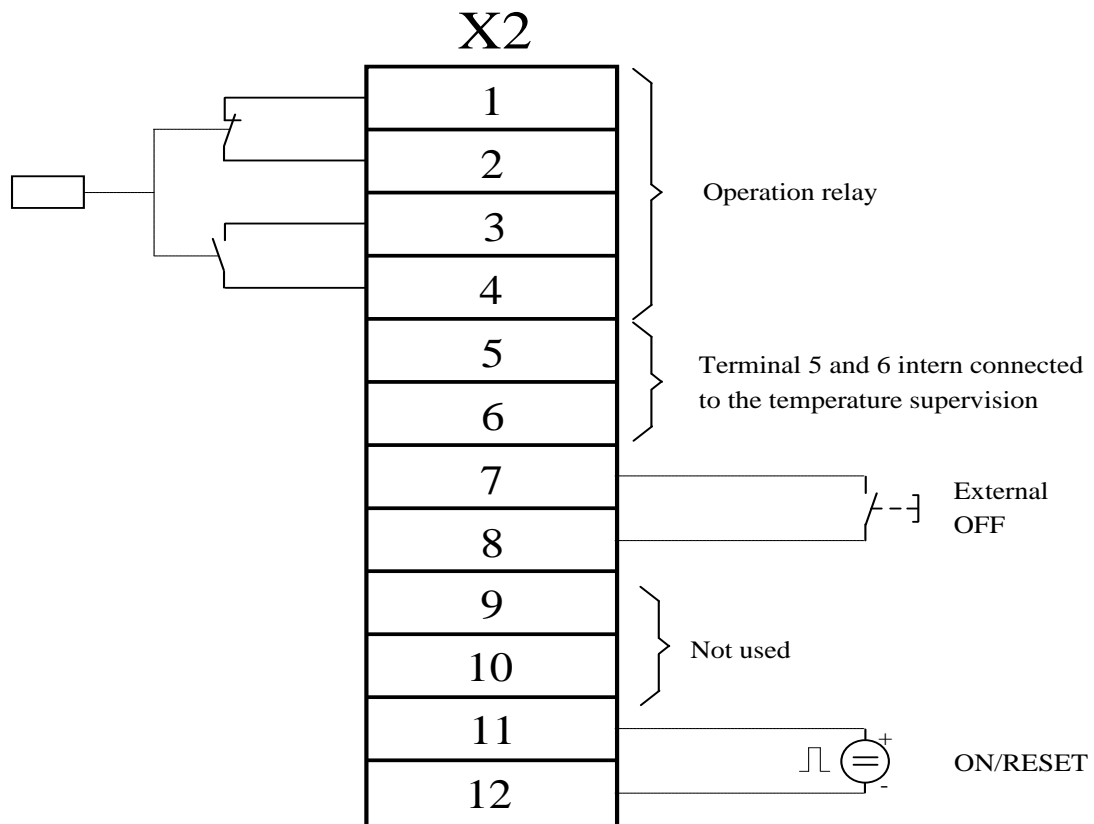

Figure 4.4.4.2



**Note!**

The terminals 5,6,9 and 10 are not lead through.



---

## Electrical Installation

---

### **Terminals 1-4 (refer to figure 4.4.4.2)**

These terminals are contacted to two potential free (SELV) relay contacts (one NOC and one NCC) with a maximum current load of 5 A AC or 3 A DC. It is not allowed to connect other voltage types than SELV!

In figure 4.4.4.2 the relay is displayed in rest position.

The relay toggles, if:

- 1.) Power supply is o.k.
- 2.) No error present, and after perhaps an **ON**-signal has been released.

If an **OFF**-signal has been released, a collective error is display as the relay toggles.

### **Terminals 5 and 6**

These terminals are already used for the internal temperature supervision of the heat sink.

### **Terminals 7 and 8**

**(Use screened wires only, maximum length)**

**OFF**-signal

These terminals may be used for an external **OFF**-signal (NOC, short time contact) to stop the power feedback unit.

---

#### **Note!**



The OFF-signal stops the feed back immediately. If this is done in regent mode, the controller would trip because of too high DC-bus voltage right afterwards.

---

### **Terminals 9 and 10**

Not used

### **Terminal 11 and 12**

**(Use screened wires only)**

These terminals may be used for an external **ON**-signal (external voltage 12 – 24V DC [e.g. from PLC], short time pulse) to start / reset the power feedback unit.

(Connect „Plus“ to terminal 11, „Minus“ to terminal 12)

## 4.5 Application example

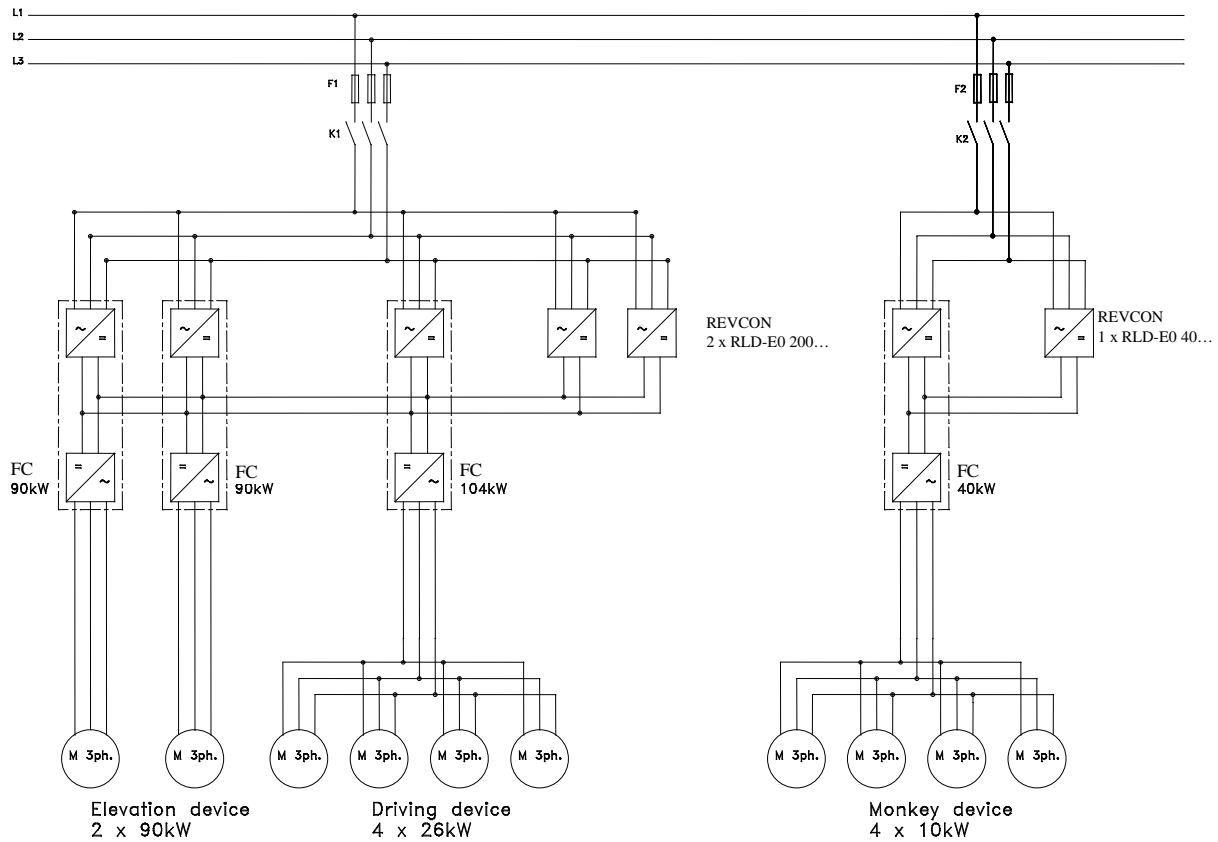

Figure 4.5.1

Within greater plants several power feedback units may be coupled. Figure 4.5.1 shows an example of a crane system with some possible combinations.

The operation of several inverters at one common DC-bus allows reducing the amount of power feedback units. On the other hand several power feedback units may be coupled to transmit more power. It's also possible to drive several motors at one inverter, as they react, seen from the DC-bus (and that's, what the power feedback unit sees), like one big motor.

To proportion such a plant it is important to look at the worst case. The maximum feed-back power of the power feedback unit has to be higher as or, at a minimum, equal to the total amount of the braking power of the connected motors.

## Electrical Installation

### 4.6 Installation of a power feedback unit in a CE-typical drive system

<b>General</b>	<ul style="list-style-type: none"> <li>• <b>The user is responsible for the compliance of his application with the EC directives.</b></li> <li>- If you observe the following measure you can be sure that the drive system will not cause any power-feed/feedback-unit-caused EMC problems, i.e. comply with the EMC Directive when running the machine.</li> <li>- If devices which do not comply with the CE requirement concerning noise immunity EN 61000-6-2 are operated close to the power feed/feedback unit, these devices may be interfered electromagnetically by the power feed/feedback units.</li> </ul>
<b>Assembly</b>	<ul style="list-style-type: none"> <li>• Connect the power feed/feedback unit and the RFI-filter to the grounded mounting plate with a wire of large cross section as possible: <ul style="list-style-type: none"> <li>– Mounting plates with conductive surfaces (zinc-coated or stainless steel) allow permanent contact.</li> <li>– Varnished boards should not be used for installation in accordance with EMC.</li> </ul> </li> <li>• If you use several mounting plates: <ul style="list-style-type: none"> <li>– Connect as much surface of the mounting plates as possible (e.g. with copper bands)</li> </ul> </li> <li>• Ensure the separation of power and control cables.</li> <li>• Cable guides as close as possible to the reference potential. Unguided cables have the same effect as aerials.</li> </ul>
<b>Filters</b>	<ul style="list-style-type: none"> <li>• Use RFI filters which are assigned to the power feed/feedback unit. RFI filters reduce impermissible high frequency interference to a permissible value.</li> </ul>
<b>Screening</b>	<ul style="list-style-type: none"> <li>• Metallic cable glands ensure a big-surface connection between screen and housing</li> <li>• If the screened wire are interrupted at relays or terminals: <ul style="list-style-type: none"> <li>- Connect the screens of the wires with a big surface to the mounting plate.</li> </ul> </li> <li>• If the mains wires between RFI-filter and power feed/feedback unit are longer than 300mm: <ul style="list-style-type: none"> <li>- Use screened mains wires</li> <li>- Connect the screen direct at the controller / power feed/feedback unit and at the RFI-filter to the mounting plate.</li> </ul> </li> <li>• Screen the control wires: <ul style="list-style-type: none"> <li>- Connect the screens on the shortest possible way to their terminals.</li> </ul> </li> </ul>
<b>Earthing</b>	<ul style="list-style-type: none"> <li>• All metallic conduction components (power feed/feedback unit, controller, RFI-filter) have to be connected to one common earthing point (PE-bus bar).</li> <li>• Observe the in the safety guidelines defined minimum cross sections: <ul style="list-style-type: none"> <li>- For EMC not the cross section, but the surface of a wire and the contact to the mounting plate is important for the function.</li> </ul> </li> </ul>

Power feedback units are electrical units for usage in industrial and commercial plants. In accordance with the EMC guideline 2004/108/EC it is not obligate to mark these units, as in the sense of the EMC directive and the EMC law they are components to be mounted by an competent electromechanical engineer and cannot be used stand alone. The proof of the observance of the protective aims of the EMC directive has to be carried out by the erector / user of the machine / plant. If the by ELTROPLAN-REVCON released RFI-filters are used and the following measures and installation directives are observed, the adherence to the prescribed data is cleared.

In combination with the related RFI-filter the power feedback unit has been designed for the usage in ambient of the limit class „A“ („B“ on request).

Definition in accordance with generic standards:

- Electromagnetic compatibility (EMC) - Part 6-4: EN 61000-6-4 and IEC 61000-6-4:2006 Generic standards-Emission standard for industrial environments.
- Electromagnetic compatibility (EMC) - Part 6-2: EN 61000-6-2 and IEC 61000-6-2 Generic standards- Immunity for industrial environments.

---

## Electrical Installation

---

### 4.6.1 Installation

#### **Appropriate design of pant and cabinet:**

To avoid noise in coupling lay

- a) Mains/supply wires
- b) Motor wires of controllers / servo amplifiers
- c) Control- and data wires (small voltage range < 48V) with a distance of at least 15 cm between each other.

To obtain low resistive HF-connections, grounding, screening and other metallic connections (e. g. mounting plates, mounted units) have to be done with an as big as possible surface to metallic ground. Use grounding and potential equalisation wires with as big cross section as possible (min. 10mm<sup>2</sup>) or thick grounding tapes.

Use copper or tinned copper screened wires only, as steel screened wires are not suitable for high frequency applications. Connect the screen with metal clamps or metal glands to the equalisation bars or PE-connections. Don't extend the screen with single wires!

If external RFI-filters are use, these have to be mounted not more than 30cm away from the noise source and with a very good, low resistive based contact.

Inductive switching units (relay, magnetic contactor and so on) have to be equipped with varistors, RC-circuits or suppressor diodes always.

All connections have to be as short as possible and must lay as close to the ground potential as possible, as free hovering wires act like aerials.

Avoid wire loops in all wires. Connect unused wires to ground at both ends.

If unscreened wires are used, twist the pairs to attenuate unsymmetrical noise.

### 4.6.2 Connection of a RFI-filter

The following figure shows mounting and connection of an external RFI-filter:

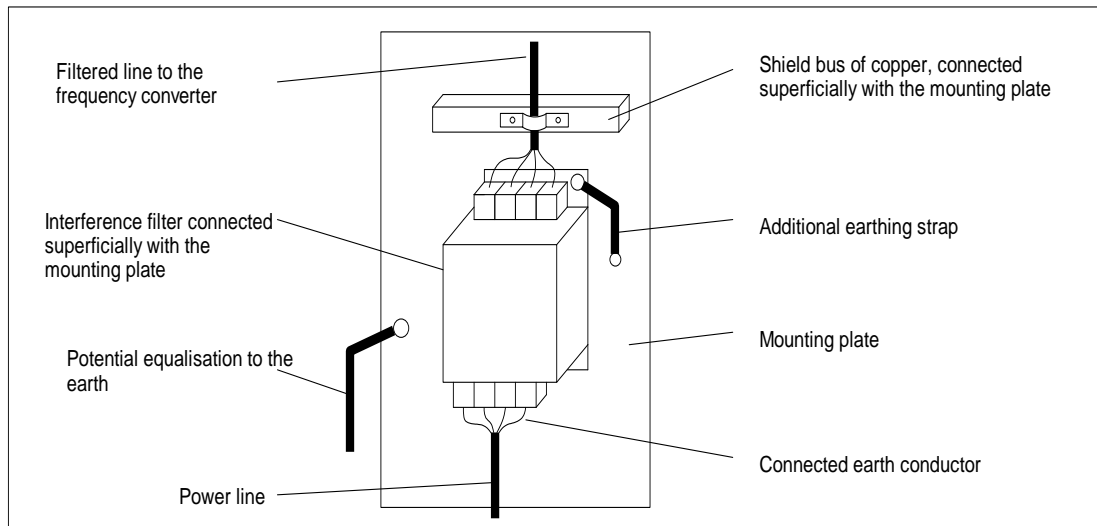

## Electrical Installation

### 4.6.3 Design of an EMC-conformal cabinet

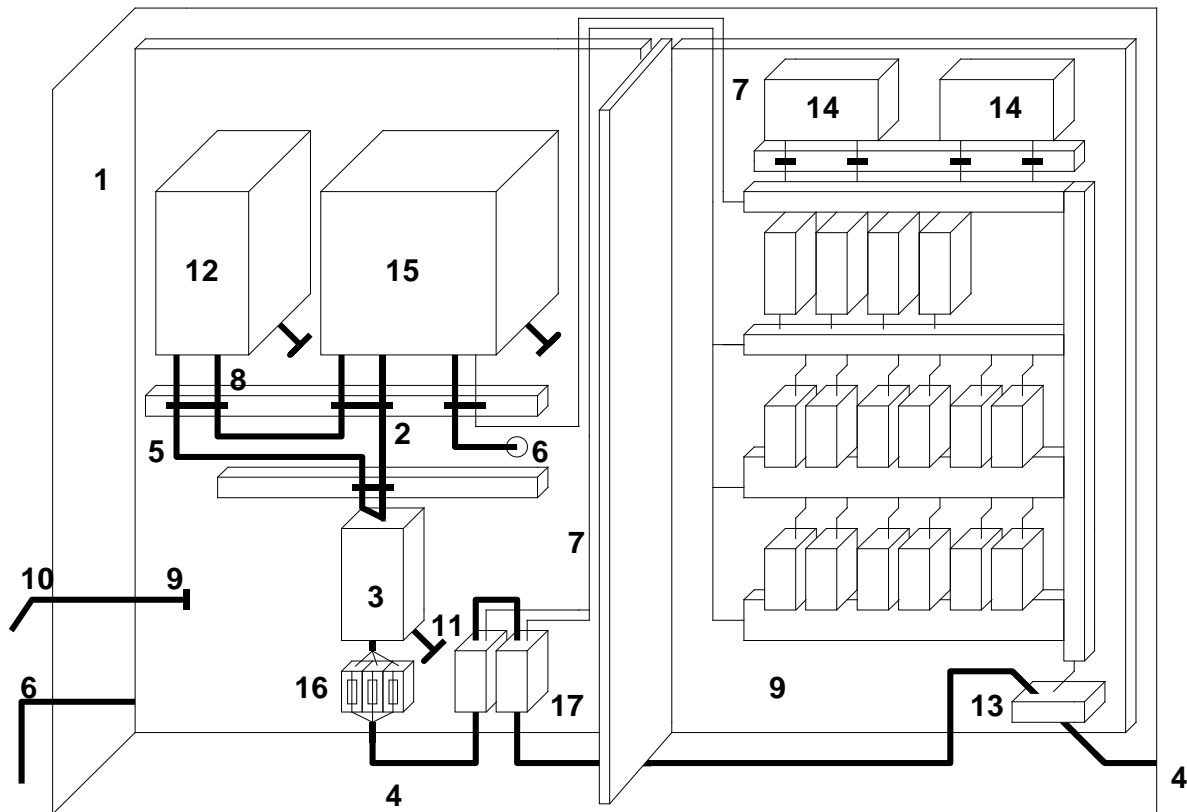

- |  |   |
|--|---|
| 1. Cabinet   | 8. DC-bus wiring<br>with power feedback unit (DC) |
| 2. Wiring between RFI-filter<br>and controller   | 9. Mounting plate (common star point)             |
| 3. RFI-filter  | 10. Potential equalisation                        |
| 4. Mains supply wire   | 11. Additional earthing wire                      |
| 5. Wiring between RFI-filter<br>and power feedback unit:<br>Cross section in accordance with fusing<br>or short circuit proof! | 12. Power feedback unit                           |
| 6. Motor wiring  | 13. Mains connection                              |
| 7. Control wiring  | 14. PLC   |
|  | 15. Controller                                    |
|  | 16. Mains fuses                                   |
|  | 17. Mains magnetic switch                         |

#### 4.6.4 Remarks

Generally a system should be divided in an area for power electronics and an area for control electronics. This is not only important, if the system is mounted in one cabinet, but even also if it is spread over several cabinets. As of the strong noise emission of the power wires it is recommended to mount a screening wall. This wall must have a low resistive contact to the frame or the mounting plate (remove lacquer!).

The installed power feedback unit and the connected RFI-filter must form an integrated whole, i.e. they have to be connected via the mounting plate without an isolating lacquer.

The connection wire between power feedback unit and RFI-filter must be screened. At both ends the screen has to be connected to ground. The wire should not be longer than 300mm.

The mounting plate of the power feedback unit should be the star point for the whole grounding and screening of the machine or plant. If the drive or other components of the plant cause interference, the HF connection of these components is bad. This could be improved by an additional potential equalisation.

By using RFI-filters the leakage current is increased. As the leakage current is higher than 3,5 mA, one of the following conditions must be fulfilled:

- Cross section of the protective wire must be at least 10 mm<sup>2</sup> CU.
- Supervision of the protective wire by a module, which trips in case of a fault.
- Install a second wire in parallel to the protective wire via separate terminals. This wire must be conformal with VDE 0100 / part 540.



## Electrical Installation

---

### 4.6.5 Installation of control wires

The screen of digital signal wires, which are not connected to terminals, has to be connected to the screen bars to decrease the impedance of the screen.

The screen of digital signal wires, which are connected to terminals, has to be connected with as big surface as possible to ground.

If the screen is grounded via a single wire, the noise discharge is getting worse by 70%.

For screen connection commercial cable clamps are suitable.

If unscreened signal wires are used, install only twisted pair wires.

## 5 Commissioning

---



### **Danger!**

Prior to initial switch-on of the power feedback unit check the wiring for completeness, short-circuit and earth fault.

---



### **Danger!**

If the wiring is not correct, a non-intended operation of controller and/or power feedback unit is possible.

---

### 5.1 First powering up

1. Switch on mains supply :
  - The power feedback unit is ready for operation after ca. 1s
2. Check the readiness for service of the power feedback unit:
  - If only the green LED is on:  
Power feedback unit is ready for service.
  - If beside the green LED also other LED's are on:  
A disturbance is present. Before proceeding with commissioning, remove the disturbance (refer to chapter 7 "Troubleshooting").
3. Check the readiness for service of the controller:
  - Proceed in accordance with the controller manual.

---

## Configuration

---

### 6 Configuration

The coding of the jumpers enables different driving possibilities and different internal functions in accordance to specific error messages.

In the following different definitions are explained which result from the specific possibilities of coding!

#### a) „Switch on“ - „Switch off“

„Switch off“ means that the driving of the semiconductors and the power feedback will be interrupted. A braking operation of the frequency inverter with power feedback is no longer possible.

„Switch-on“ is the activation of driving the semiconductors.

#### b) „Storage“

The unit is equipped with an error storage where special failures can be assigned to. Stored error messages have to be confirmed by RESET or interruption of mains supply. "Storage" always leads to a "switch-off" and to a collective-error-relay tripping.

#### c) Reset

After the failure is removed, a stored error has to be reset by pushing the RESET-button or rather by switching-off and on again the main circuit voltage (3-ph.)

---

### Danger!



A reset in case of too high DC-bus voltage during the braking operation is not recommended. If it is done nevertheless, the power semiconductors are exposed to increased stress, which may lead to accelerated aging.

---

#### d) „Phase failure“

The phase-failure-supervision monitors the mains supply in all 3 phases.

In case of a breakdown of one phase the unit stays still in function, but with reduced feedback power.

The power feedback unit reacts in different ways on phase failures. One possibility is the "2 phase operation", the other one let the system get out of operation and the collective-error-relay signals the failure.

Coding via jumper, see figure 4.4.4.1.1:

J3	J5	J6	J7	Phase-failure-supervision	
—	0	0	—	Sensitive, error storage "ON"	0 Jumper open
—	—	—	—	Insensitive, error storage "ON"	— Jumper closed
0	X	X	—	Off, but error storage "ON"	X Jumper random
0	X	X	0	Off, error storage "OFF"	

**Note:**



Jumper J7 only exists from version 1.4.2 of the control board. Error storage "ON" means that the error "phase failure" is shown via LED until you confirm. Error storage "OFF" how-ever means that the error "phase failure" is shown via LED only as long as the failure really exists.

**Danger!**



Pull off the jumper J3 is only allowed by interrupting the pulses of the frequency inverter or of the power feedback unit in the case of switching off the mains by series interrupting devices like contactors, main switches or any others. This is necessary to stop the power feedback to prevent a dangerous voltage rise on devices in the sector where the power is switched-off. The Jumper J7 should only be removed in the case of Jumper J3 is removed. Otherwise when the phase-failure-supervision is active a "phase failure" will only be shown as long as the failure exists (no error storage).

## Configuration

### e) Overvoltage supervision

Since the control board version 1.4.3 the device has an overvoltage supervision for the mains which switches off the device in the case of a voltage level of approximately  $1,15 \times U_N$  and above. As an error message the error code 3 will be shown (see chapter 7.1). For the differentiation of the error messages phase failure and overvoltage you have the possibility to deactivate the phase-failure-supervision by removing the jumper J3 on the control board. If after that a switch-off with the indication via the red and yellow LED (error code 3) happens, an overvoltage will be the reason of the switch-off then.

J3	J5	J6	J7	J8	LED Message			Evaluation (overvoltage)
—	X	X	—	—	Green	1.red	Yellow	Overvoltage a/o phase failure/commutation error
—	X	X	0	—	Green	—	Yellow	Overvoltage
0	X	X	—	—	Green	1.red	Yellow	Overvoltage a/o phase failure/commutation error
0	X	X	0	—	Green	—	Yellow	Overvoltage
0	X	X	0	—	Green	1.red	Yellow	Constant phase failure

#### **Remark:**

- 0 Jumper open
- Jumper closed
- X Jumper random

#### **Standard adjustment of the device:**

Autostart and no switching off in case of phase failure

---

## Troubleshooting and fault elimination

---

### 7 Troubleshooting and fault elimination

The five LEDs in the cover of the power feedback unit display the operating condition. For easier visibility during service and first powering up similar LED's are placed on the control board.

---

#### Stop!

If the power feedback unit trips during retardation, it must not be reset until the end of the retardation and until the DC-bus voltage has fallen to normal values.



To avoid any kind of problems you can block the impulse-release of the inverter by connecting the collective-error-relay-contact of the power-feedback-unit with the corresponding connection of the frequency inverter.

---

#### U<sub>CE</sub>-tripping:

The power feedback unit trips by the U<sub>CE</sub>-protective-circuitry, if the specific maximum current of the device is exceeded. The principle of this protective-circuitry implies that for a short time (less than one millisecond) the IGBT is stressed over its specification for normal operation. For a single case this means no problem for the power feedback unit. However, if the over current cut off arises often or even periodically, the high power semiconductors will age very rapidly and fail premature.

The cause of periodical U<sub>CE</sub> cut offs may be over load, under voltage in the network, a defective or oscillating controller, an oscillating reference input or a wrong design of the plant.

## Troubleshooting and fault elimination

### 7.1 LED-messages

	LED – display				
LED-display:	Operation	Phase failure	U <sub>CE</sub>	Over temperature	Disturbance
Error code:	Green	Red	Red	Orange	Yellow
1	X				
2	X				
3	X*			X*	X
4	X				X
5	X				X
6	X				X
7	X	X			X
8	X		X		X
9	X	X	X		X
10	X*	X	X	X*	X
11					
12	X				X
13	X	X			

Table 7.1.1

## Troubleshooting and fault elimination

LED-display Error code:	Status report		Relay status
	At commissioning	During operation	
<b>1</b>	Ready to operate (after approx. 1s)	System in operation	Relay in resting position
<b>2</b>	Ready for operation, but no power feedback ⇒ Check the DC-fuses.		Relay in resting position
<b>3</b>		Over temperature of the heat sink ⇒ Error-message is not resettable as long as the temperature is too high.	Relay dropout
<b>4</b>		Error code 3 ⇒ Heat sink temperature declined to normal and the error is resettable.	Relay dropout
<b>5</b>	System has been switched off, (external OFF) ⇒ Reset necessary	System has been switched off, (external OFF) ⇒ Reset necessary	Relay dropout
<b>6</b>	Overvoltage has been detected (J8 closed) ⇒ After grid voltage has declined to its nominal value, reset necessary		Relay dropout
<b>7</b>	Rotary field orientation incorrect or one phase is missing	Phase failure has been detected ⇒ Reset necessary	Relay dropout
<b>8</b>		Overcurrent has been detected ⇒ Reset necessary	Relay dropout
<b>9</b>	Error code 7 and 8	Overcurrent and phase failure have been detected simultaneously.	Relay dropout
<b>10</b>	Several errors have been detected simultaneously	Several errors have been detected simultaneously	Relay dropout
<b>11</b>	System off, at least two phases lost	System off, at least two phases lost.	Relay dropout
<b>12</b>		With option IFP: I <sup>2</sup> t-tripping ⇒ Reset necessary	Relay dropout
<b>13</b>		Voltage breakdown during commutation but without tripping as jumper 3 and 7 are open (chapter 6e) ⇒ Operation possible, mains supply improvement recommended	Relay dropout

Table 7.1.2



## Service

---

### 8 Service

The power feedback unit is maintenance-free, if the provided application conditions are observed (refer to chapter 3.2).

If the cooling air is polluted, the cooling air input may be blocked. Therefore check the power feedback unit periodically (depending on the degree of pollution approx. every 4 weeks).



#### **Danger!**

Don't use sharp or tapering objects like knife or screw driver to clean the cooling air input.

---

Clean the cooling air input with a vacuum cleaner.

## 9 Options

### 1. Fuse holder with fuses for mains supply

In accordance with table 3.3.3.1.1-5 for the power feedback unit the following fuses are available:

REVCON® - type	Order designation	Case type
RLD 8 to RLD 116	SH RLD ZZZ-XXX	A
RLD 140 to RLD 345	SH RLD ZZZ-XXX	B

ZZZ ≙ rated power of the power feedback unit  
 XXX ≙ rated voltage of the power feedback unit

### 2. Option IL (Isolating lacquer)

To protect the electronic components of the power feedback unit from pollution of the cooling air, all printed circuit boards may be coated with an isolating lacquer. This option improves the service reliability, but it doesn't release the user from the duty to observe the in chapter 3.2 specified application conditions.

### 3. Overvoltage-suppressor

If the power feedback unit (as well as a controller) is connected to ungrounded mains supply, it only may be run, either if it is connected via an isolating transformer or if the plant is protected by overvoltage suppressors. But also with grounded mains supply it may be useful to install overvoltage suppressors, if it is possible, that voltage peaks occur. For choosing the best overvoltage suppressor for your specific application, please get in contact with one of our technicians.

### 4. RFI-filter

Additional RFI-filters are available on request.

---

## Appendix

---

### 5. External operating an signalling panel

When mounting the device inside a cabinet it is possible to mount an operator panel in the door of the cabinet by using the external operating and signalling panel. The external operating and signalling panel contains the complete display (LED's) of all running and failure messages of the power feedback unit and also the ON / RESET push button switch.

The connection to the power feedback unit has to be done with a (shielded) flat cable to the socket X4 of the control board (refer to figure 4.4.4.1).

---

#### Note!

The connection of the external operating and signalling panel to the power feedback unit has no influence on the operating and error messages of the LED's placed on the control board. In this case both displays are active on the same time.



In case of simultaneous usage of the external operating and signalling panel and the ON/OFF function via the control terminal X2 the switch off signal always has priority, independent of the ON-RESET push button switch.

---

#### Stop!



Don't put an external voltage to the socket X4 of the control board or to the external operating and signalling panel. This may damage the device.

---

## 6. Option SLM

The option SLM adds the possibility to activate the sleep mode to reduce the standby power consumption. The user has to wire two additional terminals A1 and A2 like below. As long as no voltage is applied to A1, the power feedback unit will be completely off. To turn it on, apply 24V DC to A1. The unit will start up within the standard start up time of 3-4 seconds.

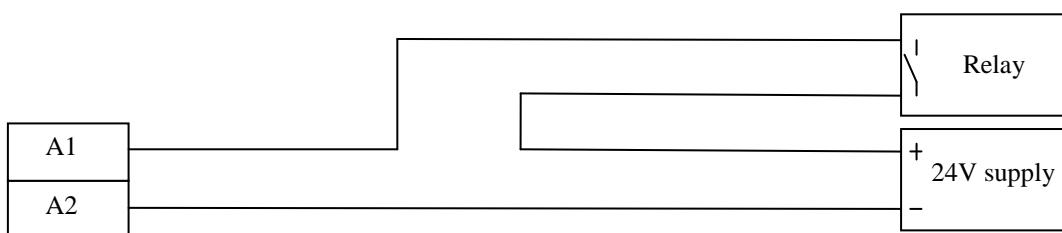

At a voltage of 24V the current consumption at terminals A1/A2 is 10,4mA, therefore the source must supply ca. 0,3W. The load is a DC load; the turn off voltage will be limited by a flyback diode.

## 7. Option FS

The option FS reduced the start up time to less than 1s. This option must be combined with the option SLM.

---

## Appendix

---

### 10 REVCON® product overview

#### 1. REVCON® RHD

Power feedback units for continuous operation

(Engine test beds, escalators, wind energy plants, elevators etc.)

#### 2. REVCON® RFE

Power supply- and feedback unit

For multiple motor applications with dynamic alternation of loads)

#### 3. REVCON® RSU

Step- up converter for the generation of a current controlled, high output voltage from a lower input DC voltage.

#### 4. REVCON® RSD

Step- down converter for the generation of a decreased output voltage from a higher DC voltage (AC output is also possible).

- Voltage controlled: A free selectable output voltage in wide limits

The required output voltage can be adjusted by set-point (0 ... 10V)

- Current controlled: A lower output voltage that adjusts free in dependence of the load

The required output current can be adjusted by set-point (0 ... 10V)

#### 5. REVCON® EDC

Power supply module for multiple motor applications (supply of multiple drive controller) without generator- operation

#### 6. REVCON® RHF

Filter module for the generation of sinusoidal line currents (THD I 5-16% according to the frequency converter and the load). Filter module of the newest generation with smaller dimensions and reduced weight and better performance

All products are available for 400V line voltage, optionally the most also for 230V, 400V, 460V, 500V, 600V and 690V! According to the product power from 8 to 345kW can be transmitted, whereby the most products are appropriate for parallel connection, so that power ratings until the megawatt range can be achieved!

## 10.1 Contact

**Eltroplan-REVCON Elektrotechnische Anlagen GmbH**

**Edisonstraße 3**

**D-59199 Bönen**

**Phone +49 (0)2383 920 22 22**

**Fax +49 (0)2383 920 22 66**

**E-Mail [info@REVCON.de](mailto:info@REVCON.de)**

**Web [www.REVCON.de](http://www.REVCON.de)**

< SUBJECT TO CHANGE WITHOUT NOTICE >

15/11

---

The in these operating instructions contained details and technical data must be checked by the costumer before acquisition and application. The costumer can raise no claims from these documents, compared to Eltroplan- REVCON® or Eltroplan- REVCON®-staff, unless that these have acted intentional or grossly negligent. Eltroplan- REVCON® reserves the right to perform, without previous announcements within the appropriate and reasonable changes at their products - also at already commissioned. All rights reserved.

---

## Index

<b>A</b>		<b>O</b>	
application conditions.....	28	operating and signalling board, external .....	90
<b>C</b>		operator's safety .....	15, 59
cable glands.....	74	ordering code.....	4
CE-marking .....	6	overvoltage suppressor.....	89
compensation plants.....	11, 26	<b>P</b>	
connection .....	61, 62	patents rights .....	5
contact .....	93	personnel	
controller.....	3, 11	qualified.....	9
cooling air.....	39	pictograms .....	15
current load.....	72	power feedback unit .....	3
<b>D</b>		protection of the device.....	15
drive system .....	3, 10, 14	<b>R</b>	
drive systems .....	5	rated data .....	29
<b>E</b>		readiness for service .....	81
EC-Directives .....	5	RFI-filter .....	51, 54, 69
Efficiency .....	29	RHF-RA-module.....	38
ESDS .....	59	<b>S</b>	
<b>F</b>		safety information .....	9, 10, 15
fan supply.....	69	screening.....	69, 74
filtering.....	74	standards .....	7, 8, 61, 62
free spaces .....	39	<b>T</b>	
fuses		terminal usage .....	71
-serial .....	32, 89	transport .....	9, 28
<b>G</b>		transport damage .....	4
generator .....	11, 19	troubleshooting .....	81, 85
<b>I</b>		<b>U</b>	
isolating lacquer .....	89	UL.....	60, 61
<b>L</b>		user .....	14
low-voltage directive.....	6, 9, 28	<b>V</b>	
<b>M</b>		voltage, external .....	90
Mains frequency .....	29	<b>W</b>	
mains terminals.....	32	Warning.....	15
mains types .....	60	warranty.....	5, 11
mounting position.....	39	wires	
		screened .....	60
		wiring schematic .....	63, 65, 67