

# **SERVICE MANUAL**

---

## **SERVICE MANUAL SECTION**

### **LoneStar® and ProStar® Chassis Built January, 2007 and After — ELECTRICAL CIRCUIT DIAGRAMS**

**Model: LoneStar**

**Model: ProStar**

**Start Date: 01/15/2007**

**S08339**

**02/17/2010**



---

## Table of Contents

1. TABLE OF CONTENTS (CHAPTER 1).....	1
2. INSTRUCTIONS AND CHARTS (CHAPTER 2).....	1
2.1. ABBREVIATIONS, P. 1.....	1
2.2. ACRONYMS, P. 2.....	2
2.3. CIRCUIT DIAGRAM INSTRUCTIONS, P. 3.....	3
2.4. CIRCUIT NUMBER IDENTIFICATION AND COLOR, P. 4.....	4
2.5. CIRCUIT NUMBER IDENTIFICATION AND COLOR (CONT.), P. 5.....	5
2.6. CIRCUIT NUMBER IDENTIFICATION AND COLOR (CONT.), P. 6.....	6
2.7. LAMP BULB CHART, P. 7.....	7
2.8. RELAY FUNCTION AND WIRING GUIDE, P. 8.....	8
2.9. SCHEMATIC SYMBOL CHART, P. 9.....	9
2.10. SCHEMATIC SYMBOL CHART (CONT.), P. 10.....	10
2.11. SCHEMATIC SYMBOL CHART (CONT.), P. 11.....	11
2.12. SCHEMATIC SYMBOL CHART (CONT.), P. 12.....	12
3. 12 VOLT POWER DISTRIBUTION CIRCUIT DIAGRAMS (CHAPTER 3).....	13
3.1. BATTERY FEED, P. 1.....	13
3.2. BATTERY FEED (CONT.), P. 2.....	14
3.3. BATTERY FEED (CONT.), P. 3.....	15
3.4. BATTERY FEED (CONT.), P. 4.....	16
3.5. BLANK PAGE, P. 5.....	17
3.6. BLANK PAGE, P. 6.....	18
3.7. IGNITION FEED — STANDARD AND REMOTE START/STOP, P. 7.....	19
3.8. IGNITION FEED — ICON, P. 8.....	20
3.9. IGNITION FEED — STANDARD, P. 9.....	21
3.10. IGNITION FEED — STANDARD (LONESTAR), P. 9A.....	22
3.11. ACCESSORY FEED, P. 10.....	23
3.12. CAB J1939 COMPASS AND ABS EFFECTS, P. 11.....	24
3.13. CAB J1939 WITH ALL OPTIONS, P. 12.....	25
3.14. CAB J1939 WITH ALL OPTIONS, P. 13.....	26
3.15. CAB J1939 WITH ALL OPTIONS, P. 13A.....	27
3.16. CAB J1939 WITH ALL OPTIONS, P. 14.....	28
3.17. J1939 ENGINE, P. 15.....	29
3.18. J1939 CHASSIS, P. 16.....	30
3.19. J1939 WITH SLEEPER, P. 17.....	31
3.20. J1708 PRIVATE, P. 18.....	32
3.21. J1708 PUBLIC, P. 19.....	33
3.22. J1708 PUBLIC, P. 20.....	34
3.23. J1708 PUBLIC, P. 20A.....	35
3.24. GROUND — CAB, P. 21.....	36
3.25. GROUND — CAB, P. 22.....	37
3.26. GROUND — CAB, P. 22A.....	38
3.27. GROUND — CAB, P. 23.....	39
3.28. GROUND — CAB, P. 24.....	40
3.29. GROUND — CAB, P. 25.....	41
3.30. GROUND — CAB, P. 26.....	42

---

3.31. GROUND — CHASSIS, P. 27.....	43
3.32. GROUND — SLEEPER, P. 28.....	44
3.33. GROUND — SLEEPER, P. 29.....	45
3.34. GROUND — SLEEPER, P. 29A.....	46
3.35. ENGINE GROUND — IBB ENGINE, P. 30.....	47
3.36. J1939 DATA LINK — IBB ENGINE, P. 31.....	48
3.37. ZERO VOLT REFERENCE, P. 32.....	49
3.38. ZERO VOLT REFERENCE, P. 32A.....	50
4. CAB ACCESSORIES (CHAPTER 4).....	51
4.1. CB POWER RADIO, P. 1.....	51
4.2. CIGAR LIGHTER AND TEMPERATURE DISPLAY, P. 2.....	52
4.3. ELECTRIC WINDOWS AND DOOR LOCKS, P. 3.....	53
4.4. ELECTRIC HORN, P. 4.....	54
4.5. MIRRORS HEATED AND LIGHTED, P. 5.....	55
4.6. MIRRORS HEATED AND LIGHTED, P. 6.....	56
4.7. TELEMATICS, P. 7.....	57
4.8. SATELLITE COMMUNICATION SYSTEM — QUALCOMM TMCT DAYCAB, P. 8.....	58
4.9. SATELLITE COMMUNICATION SYSTEM — QUALCOMM TMCT DAYCAB, P. 9.....	59
4.10. SATELLITE COMMUNICATION SYSTEM — QUALCOMM TMCT SLEEPER, P. 10.....	60
4.11. SATELLITE COMMUNICATION SYSTEM — QUALCOMM TMCT SLEEPER, P. 11.....	61
4.12. SATELLITE COMMUNICATION SYSTEM — QUALCOMM IMCT, P. 12.....	62
4.13. SATELLITE COMMUNICATION SYSTEM — QUALCOMM IMCT, P. 13.....	63
4.14. QUALCOMM IMCT — SLEEPER, P. 14.....	64
4.15. PANIC BUTTON, P. 15.....	65
4.16. SATELLITE COMMUNICATION SYSTEM — XATA WITH DAYCAB, P. 16.....	66
4.17. SATELLITE COMMUNICATION SYSTEM — XATA WITH SLEEPER, P. 17.....	67
4.18. RADIO ENTERTAINMENT, SPEAKERS, P. 18.....	68
4.19. RADIO ENTERTAINMENT, SPEAKERS, P. 18A.....	69
4.20. RADIO ENTERTAINMENT, SPEAKERS, P. 19.....	70
4.21. RADIO ENTERTAINMENT, SPEAKERS, P. 19A.....	71
4.22. SWITCH PACK, P. 20.....	72
4.23. WINDSHIELD WIPER MOTOR, P. 21.....	73
4.24. WINDSHIELD WASHER PUMP, P. 22.....	74
4.25. DISPLAY, VEHICLE INFORMATION (VID), P. 23.....	75
4.26. DISPLAY, DRIVER INTERFACE (DID), P. 23A.....	76
4.27. CAT MESSENGER DISPLAY, P. 24.....	77
4.28. BEACON LIGHT SWITCH — FOR DUAL CUSTOMER ACCESSORY, P. 25.....	78
4.29. DOOR SWITCHES — DOME LAMP, P. 26.....	79
4.30. SPARE SWITCH — FOR SINGLE CUSTOMER ACCESSORY, P. 27.....	80
4.31. SPARE SWITCH — FOR DUAL CUSTOMER ACCESSORY, P. 28.....	81
4.32. EATON VORAD EVT-300 SYSTEM, P. 29.....	82
4.33. EATON VORAD EVT-300 SYSTEM, P. 30.....	83
4.34. EATON VORAD VS-400, P. 31.....	84
4.35. WABCO ONGUARD WARNING SYSTEM, P. 31A.....	85
4.36. AWARE II, P. 32.....	86
4.37. AWARE II, P. 33.....	87
4.38. AWARE II, P. 34.....	88
4.39. AWARE II, P. 35.....	89
4.40. AWARE II, P. 36.....	90
4.41. QUALCOMM OMNIVISION, P. 37.....	91
4.42. QUALCOMM OMNIVISION, P. 38.....	92
4.43. MOTIENT MOBILE MAX, P. 39.....	93

---

---

4.44. REMOTE RADIO — N/AMP AND N/WIRED REMOTE AND N/DRIVER INTERFACE DISPLAY, P. 40.....	94
4.45. REMOTE RADIO — W/AMP AND N/WIRED REMOTE AND N/DRIVER INTERFACE DISPLAY, P. 40A.....	95
4.46. REMOTE RADIO — N/AMP AND W/WIRED REMOTE AND N/DRIVER INTERFACE DISPLAY, P. 40B.....	96
4.47. REMOTE RADIO — W/AMP AND W/WIRED REMOTE AND N/DRIVER INTERFACE DISPLAY, P. 40C.....	97
4.48. REMOTE RADIO — N/AMP AND N/WIRED REMOTE AND W/DRIVER INTERFACE DISPLAY, P. 41.....	98
4.49. REMOTE RADIO — W/AMP AND N/WIRED REMOTE AND W/DRIVER INTERFACE DISPLAY, P. 41A.....	99
4.50. REMOTE RADIO — N/AMP AND W/WIRED REMOTE AND W/DRIVER INTERFACE DISPLAY, P. 41B.....	100
4.51. REMOTE RADIO — W/AMP AND W/WIRED REMOTE AND W/DRIVER INTERFACE DISPLAY, P. 41C.....	101
5. CHARGING AND CRANKING SYSTEM (CHAPTER 5).....	102
5.1. MANUAL TRANSMISSION, P. 1.....	102
5.2. MANUAL TRANSMISSION (CAT ENGINE), P. 1A.....	103
5.3. AUTOMATIC TRANSMISSION, P. 2.....	104
5.4. AUTOMATIC TRANSMISSION (CAT ENGINE), P. 2A.....	105
5.5. FREEDOMLINE TRANSMISSION, P. 3.....	106
5.6. FREEDOMLINE TRANSMISSION (CAT ENGINE), P. 3A.....	107
6. ETHER START AND FAN WIRING (CHAPTER 6).....	108
6.1. ETHER START CUMMINS ISX, P. 1.....	108
6.2. FAN WIRING, P. 2.....	109
6.3. FAN WIRING — IBB ENGINE, P. 3.....	110
6.4. STARTING AID — COLD START ASSIST (IBB ENGINE), P. 4.....	111
7. ENGINES (CHAPTER 7).....	112
7.1. ELECTRONIC ENGINE CONTROLS, P. 1.....	112
7.2. ELECTRONIC ENGINE CONTROLS — CUMMINS ENGINE, P. 2.....	113
7.3. ELECTRONIC ENGINE CONTROLS — CAT ENGINE, P. 2A.....	114
7.4. ELECTRONIC ENGINE CONTROLS — CUMMINS ENGINES, P. 3.....	115
7.5. ELECTRONIC ENGINE CONTROLS WITH ICON, P. 4.....	116
7.6. ELECTRONIC ENGINE CONTROLS WITH ICON, P. 5.....	117
7.7. ELECTRONIC ENGINE CONTROLS WITH ICON, P. 6.....	118
7.8. REMOTE START/STOP, P. 7.....	119
7.9. REMOTE START/STOP, P. 8.....	120
7.10. REMOTE START/STOP, P. 8A.....	121
7.11. NO IDLE ENGINE HEAT, P. 9.....	122
7.12. TRI-PAC NO IDLE, P. 10.....	123
7.13. ELECTRONIC ENGINE CONTROLS (IBB ENGINE), P. 11.....	124
7.14. ELECTRONIC ENGINE CONTROLS (IBB ENGINE), P. 12.....	125
7.15. ELECTRONIC ENGINE CONTROLS (IBB ENGINE), P. 12A.....	126
7.16. ELECTRONIC ENGINE CONTROLS (IBB ENGINE), P. 13.....	127
7.17. ELECTRONIC ENGINE CONTROLS (IBB ENGINE), P. 14.....	128
7.18. ELECTRONIC ENGINE CONTROLS (IBB ENGINE), P. 15.....	129
7.19. AFTERTREATMENT (IBB ENGINE), P. 16.....	130
8. GAUGES AND WARNING LIGHTS (CHAPTER 8).....	131

---

---

8.1. AIR PRESSURE INPUT CIRCUIT AND AIR RESTRICTION GAUGE, P. 1.....	131
8.2. AXLE TEMPERATURE GAUGES, P. 2.....	132
8.3. ENGINE OIL PRESSURE AND TEMPERATURE, SPEEDOMETER, TACHOMETER, VOLTMETER AND WATER TEMP. GAUGES, P. 3.....	133
8.4. ENGINE OIL AND TRANSMISSION OIL TEMPERATURE GAUGES, P. 4.....	134
8.5. FUEL HEATER, P. 5.....	135
8.6. FUEL TRANSFER PUMP FOR DUAL TANK, P. 6.....	136
8.7. DIFFERENTIAL LOCK AND OPTIONAL INDICATOR, P. 7.....	137
8.8. DIFFERENTIAL LOCK AND OPTIONAL INDICATOR, P. 8.....	138
8.9. BLANK PAGE, P. 9.....	139
8.10. IP / GAUGES, P. 10.....	140
8.11. IP / GAUGES AND WARNING LIGHTS — GAUGE CLUSTER, P. 11.....	141
8.12. SECONDARY INSTRUMENT CLUSTER, P. 12.....	142
8.13. PARKING WARNING LIGHT, P. 13.....	143
8.14. WARNING LIGHTS, P. 14.....	144
8.15. IP TEXT MESSAGES AND WARNING LIGHTS — CONTROLLED BY ENGINE, TRANSMISSION AND ABS CONTROLLER, P. 15.....	145
8.16. DIFFERENTIAL LOCK AND OPTIONAL INDICATOR, P. 16.....	146
<b>9. LIGHTING SYSTEM (CHAPTER 9).....</b>	<b>147</b>
9.1. LIGHTS — STOP, TAIL, TURN AND BACK-UP N/FREEDOMLINE, P. 1.....	147
9.2. LIGHTS — STOP, TAIL, TURN AND BACK-UP N/FREEDOMLINE, P. 1A.....	148
9.3. LIGHTS — STOP, TAIL, TURN AND BACK-UP W/FREEDOMLINE, P. 2.....	149
9.4. LIGHTS — STOP, TAIL, TURN AND BACK-UP W/FREEDOMLINE, P. 2A.....	150
9.5. DOME/MAP AND COURTESY LIGHTS — DAY CAB, P. 3.....	151
9.6. DOME/MAP AND COURTESY LIGHTS — SLEEPER, P. 4.....	152
9.7. FOG LIGHTS AND SPOT LIGHT, P. 5.....	153
9.8. HEADLIGHTS, P. 6.....	154
9.9. TRIPMASTER, P. 7.....	155
9.10. TURN AND STOP SWITCH, P. 8.....	156
9.11. LIGHT SYSTEM — PARK, MARKER, CLEARANCE, ID, TURN, STOP, TAIL, P. 9.....	157
9.12. LIGHT SYSTEM — PARK, MARKER, FRONT TURN AND MODESTY PANEL LIGHT, P. 10.....	158
9.13. LIGHT SYSTEM — CLEARANCE, ID, P. 11.....	159
9.14. LIGHT SYSTEM — SKIRT LIGHT, P. 12.....	160
9.15. TRAILER LIGHT SYSTEM — MARKER, STOP, TAIL, TURN, P. 13.....	161
9.16. TRAILER SOCKET — BOC, P. 14.....	162
9.17. TRAILER SOCKET — BOC AND EOF, P. 15.....	163
9.18. TRAILER SOCKET — AUXILIARY, P. 16.....	164
9.19. FLOOR LIGHT, P. 17.....	165
9.20. DOME AND ACCENT LIGHT — SLEEPER, P. 18.....	166
9.21. DOME AND ACCENT LIGHT — SLEEPER, P. 19.....	167
9.22. LIGHTED AIR SHIELD, P. 20.....	168
9.23. PANEL LIGHTS, P. 21.....	169
9.24. WORK LIGHTS — DAY CAB, P. 22.....	170
9.25. WORK LIGHTS — SLEEPER CAB, P. 23.....	171
9.26. DOME AND ACCENT LIGHTS — SLEEPER, P. 24.....	172
<b>10. CHASSIS ACCESSORIES (CHAPTER 10).....</b>	<b>173</b>
10.1. TIRE PRESSURE MONITOR, P. 1.....	173
10.2. AIR DRYER, P. 2.....	174
10.3. AIR SOLENOID PACK — 4 WAY, P. 3.....	175
10.4. AIR SOLENOID PACK — 4 WAY, P. 4.....	176

---

---

10.5. AIR SUSPENSION W/LOAD INDICATOR, P. 5.....	177
10.6. BATTERY FEED — TRAILER AUXILIARY, P. 6.....	178
10.7. ANTILOCK BRAKE SYSTEM W/BENDIX, P. 7.....	179
10.8. ANTILOCK BRAKE SYSTEM W/BENDIX, P. 7A.....	180
10.9. ANTILOCK BRAKE SYSTEM W/BENDIX, P. 8.....	181
10.10. ANTILOCK BRAKE SYSTEM W/BENDIX, P. 9.....	182
10.11. ANTILOCK BRAKE SYSTEM W/BENDIX, P. 10.....	183
10.12. ANTILOCK BRAKE SYSTEM W/BENDIX, P. 11.....	184
10.13. ANTILOCK BRAKE SYSTEM W/BENDIX, P. 12.....	185
10.14. ANTILOCK BRAKE SYSTEM W/WABCO, P. 13.....	186
10.15. ANTILOCK BRAKE SYSTEM W/WABCO, P. 14.....	187
10.16. ANTILOCK BRAKE SYSTEM W/WABCO, P. 15.....	188
10.17. ANTILOCK BRAKE SYSTEM W/WABCO, P. 16.....	189
10.18. ANTILOCK BRAKE SYSTEM W/WABCO, P. 17.....	190
10.19. POWER TAKE OFF, P. 18.....	191
10.20. FUEL LEVEL, P. 19.....	192
10.21. VEHICLE SENSOR MODULE, P. 20.....	193
10.22. VEHICLE SENSOR MODULE, P. 21.....	194
10.23. BRAKE SENSOR — WEAR/STROKE, P. 22.....	195
10.24. BRAKE SENSOR — WEAR/STROKE, P. 23.....	196
11. TRANSMISSION CONTROL MODULE (CHAPTER 11).....	197
11.1. EATON AUTOSHIFT AND ULTRASHIFT TRANSMISSION, P. 1.....	197
11.2. EATON AUTOSHIFT AND ULTRASHIFT TRANSMISSION, P. 1A.....	198
11.3. COLUMN SHIFTER AND MERITOR G TRANSMISSION, P. 2.....	199
11.4. FREEDOMLINE TRANSMISSION, P. 3.....	200
12. HVAC (CHAPTER 12).....	201
12.1. AIR CONDITIONING, P. 1.....	201
12.2. HVAC SYSTEM — CAB, P. 2.....	202
12.3. HVAC SYSTEM — CAB, P. 3.....	203
12.4. HVAC SYSTEM — SLEEPER, P. 4.....	204
12.5. HVAC SYSTEM — SLEEPER, P. 4A.....	205
12.6. HVAC SYSTEM — SLEEPER, P. 5.....	206
12.7. NO IDLE HEAT AND HVAC — SWITCHES, P. 6.....	207
12.8. NO IDLE HEAT AND HVAC — APU, P. 7.....	208
12.9. NO IDLE HEAT AND HVAC — SENSORS AND HVAC CONTROL, P. 8.....	209
12.10. NO IDLE HEAT AND HVAC — POWER SUPPLY, P. 9.....	210
12.11. NO IDLE HEAT AND HVAC — HEAT VALVE, LPM AND BLEND MOTOR, P. 10.....	211
12.12. NO IDLE HEAT AND HVAC — FUEL FIRED HEATER AND A/C COMPRESSOR, P. 11.....	212
12.13. NO IDLE HEATER, WEBASTO IN CAB FUEL FIRED HEATER W/LVD, P. 12.....	213
12.14. NO IDLE HEATER, ESPAR IN CAB FUEL FIRED HEATER, P. 13.....	214
12.15. HVAC SYSTEM — SLEEPER W/BERGSTROM NO IDLE, P. 14.....	215
12.16. NO IDLE HVAC W/BERGSTROM HVAC SWITCHES — LOCATED IN SLEEPER CONTROL PANEL, P. 15.....	216
12.17. NO IDLE HVAC W/BERGSTROM HVAC SWITCHES — LOCATED IN SLEEPER CONTROL PANEL, P. 16.....	217
12.18. NO IDLE HVAC W/BERGSTROM HVAC POWER SUPPLY, P. 17.....	218
12.19. NO IDLE HVAC W/BERGSTROM ENGINE PRE-HEAT VALVE, P. 18.....	219
12.20. NO IDLE HVAC W/BERGSTROM FUEL FIRED HEATER, P. 19.....	220
12.21. NO IDLE HEATER, WEBASTO IN CAB FUEL FIRED HEATER N/LVD, P. 21.....	221
13. BUNK LIGHTS AND ACCESSORIES (CHAPTER 13).....	222

---

---

13.1. READING AND WARDROBE LIGHTS — BUNK, P. 1.....	222
13.2. LUGGAGE COMPARTMENT LIGHTS — BUNK, P. 2.....	223
13.3. POWER SOURCE — BUNK, P. 3.....	224
13.4. TV / REFRIGERATOR WIRING, P. 4.....	225
13.5. SPEAKER — BUNK, P. 5.....	226
13.6. FAN — BUNK, P. 6.....	227
13.7. SKY RISE LIGHTS — BUNK, P. 7.....	228
13.8. FLAT PANEL TV/DVD PLAYER — BUNK, P. 8.....	229
14. CONNECTOR COMPOSITES (CHAPTER 14).....	230
14.1. CONNECTOR COMPOSITES (7A), (8A), (9A), (10A), P. 1.....	230
14.2. CONNECTOR COMPOSITES (10F), (11A), (12A), (13A), P. 1A.....	231
14.3. CONNECTOR COMPOSITES (14A), (344), (345), (512), (520), P. 1B.....	232
14.4. CONNECTOR COMPOSITES (521), (522), (523), (524), P. 2.....	233
14.5. CONNECTOR COMPOSITES (1002), (1003), P. 3.....	234
14.6. CONNECTOR COMPOSITES (1006), (1007), (1010), (1015), P. 4.....	235
14.7. CONNECTOR COMPOSITE (1010), P. 5.....	236
14.8. CONNECTOR COMPOSITE (1011), P. 6.....	237
14.9. CONNECTOR COMPOSITE (1012), P. 7.....	238
14.10. CONNECTOR COMPOSITE (1013), P. 8.....	239
14.11. CONNECTOR COMPOSITE (1014), P. 9.....	240
14.12. CONNECTOR COMPOSITE (1015), P. 10.....	241
14.13. CONNECTOR COMPOSITE (1016), P. 11.....	242
14.14. CONNECTOR COMPOSITE (1017), P. 12.....	243
14.15. CONNECTOR COMPOSITE (1018), P. 13.....	244
14.16. CONNECTOR COMPOSITE (1019), P. 14.....	245
14.17. CONNECTOR COMPOSITE (1020), P. 15.....	246
14.18. CONNECTOR COMPOSITES (1023), (1024), P. 16.....	247
14.19. CONNECTOR COMPOSITES (1025), (1026), P. 16A.....	248
14.20. CONNECTOR COMPOSITES (1100M), (1101M), (1110M), P. 17.....	249
14.21. CONNECTOR COMPOSITES (1111M), (1112M), (1113M), P. 18.....	250
14.22. CONNECTOR COMPOSITES (1114M), (1115M), (1116M), (1117M), P. 19.....	251
14.23. CONNECTOR COMPOSITES (1200), (1210), (1215), P. 20.....	252
14.24. CONNECTOR COMPOSITES (1300), (1301), P. 21.....	253
14.25. CONNECTOR COMPOSITES (1305), (1378), P. 21A.....	254
14.26. CONNECTOR COMPOSITES (1400), (1401), (1402), P. 22.....	255
14.27. CONNECTOR COMPOSITES (1403), (1410), (1420), P. 23.....	256
14.28. CONNECTOR COMPOSITES (1421), (1422), (1423), P. 24.....	257
14.29. CONNECTOR COMPOSITES (1500), (1501), P. 24A.....	258
14.30. CONNECTOR COMPOSITES (1502), (1510), P. 25.....	259
14.31. CONNECTOR COMPOSITES (1511), (1550), (1556), P. 26.....	260
14.32. CONNECTOR COMPOSITES (1557), (1600), P. 27.....	261
14.33. CONNECTOR COMPOSITE (1601), P. 28.....	262
14.34. CONNECTOR COMPOSITE (1602), P. 29.....	263
14.35. CONNECTOR COMPOSITES (1603), (1604), P. 30.....	264
14.36. CONNECTOR COMPOSITES (1620), (1650), (1657), (1657M), P. 31.....	265
14.37. CONNECTOR COMPOSITES (1660), (1661), P. 32.....	266
14.38. CONNECTOR COMPOSITE (1700), P. 33.....	267
14.39. CONNECTOR COMPOSITE (1700F), P. 34.....	268
14.40. CONNECTOR COMPOSITE (1701), P. 35.....	269
14.41. CONNECTOR COMPOSITE (1701F), P. 36.....	270
14.42. CONNECTOR COMPOSITE (1702), P. 37.....	271
14.43. CONNECTOR COMPOSITE (1702), P. 38.....	272

---

14.44. CONNECTOR COMPOSITE (1702), P. 38A.....	273
14.45. CONNECTOR COMPOSITE (1702), P. 38B.....	274
14.46. CONNECTOR COMPOSITE (1800), P. 39.....	275
14.47. CONNECTOR COMPOSITE (1800F), P. 40.....	276
14.48. CONNECTOR COMPOSITES (1801), (1802), (1803), P. 41.....	277
14.49. CONNECTOR COMPOSITES (1804), (1805), (1806), P. 42.....	278
14.50. CONNECTOR COMPOSITES (1808), (1809), (1810), P. 43.....	279
14.51. CONNECTOR COMPOSITES (1811), (1812), (1820F/1820M), P. 44.....	280
14.52. CONNECTOR COMPOSITES (1821), (1822), (1823), (1824), P. 45.....	281
14.53. CONNECTOR COMPOSITES (1860), (1861), (1901), (1903), P. 46.....	282
14.54. CONNECTOR COMPOSITES (1906), (1907), (1909M), (1910), (1912), (1916), P. 47.....	283
14.55. CONNECTOR COMPOSITES (1917), (1918/1918A), (1919/1919A), (1920), (1922), (1922M), P. 48.....	284
14.56. CONNECTOR COMPOSITES (1923), (1925), P. 49.....	285
14.57. CONNECTOR COMPOSITES (1927), (1929), (1930), (1931), P. 50.....	286
14.58. CONNECTOR COMPOSITES (1932), (1933), (1942/1942F), (1943), (1943M), P. 50A.....	287
14.59. CONNECTOR COMPOSITES (1944), P. 50B.....	288
14.60. CONNECTOR COMPOSITES (1953), (1960), P. 51.....	289
14.61. CONNECTOR COMPOSITES (1960), P. 52.....	290
14.62. CONNECTOR COMPOSITES (1962), P. 53.....	291
14.63. CONNECTOR COMPOSITES (1962), P. 54.....	292
14.64. CONNECTOR COMPOSITES (1963), (1964), P. 55.....	293
14.65. CONNECTOR COMPOSITES (1970), (1973), P. 56.....	294
14.66. CONNECTOR COMPOSITES (1974), (1975), P. 56A.....	295
14.67. CONNECTOR COMPOSITES (2000), P. 56B.....	296
14.68. CONNECTOR COMPOSITES (2002M), (2003M), (2004M), (2005M), (2006M), (2007F), P. 57.....	297
14.69. CONNECTOR COMPOSITES (2100), (2101), (2102), (2103), P. 58.....	298
14.70. CONNECTOR COMPOSITES (2200), (2201), P. 59.....	299
14.71. CONNECTOR COMPOSITES (2224), (2225), (2227), P. 59A.....	300
14.72. CONNECTOR COMPOSITES (2300), (2301), (2302), P. 60.....	301
14.73. CONNECTOR COMPOSITES (2303F/2303M), (2304), (2312), P. 60A.....	302
14.74. CONNECTOR COMPOSITES (2313), (2500), P. 61.....	303
14.75. CONNECTOR COMPOSITES (3000), (3003/3003M), (3100/3100M), P. 62.....	304
14.76. CONNECTOR COMPOSITES (3200/3200F), (3201M), (3202M), (3203), (3203M), P. 63.....	305
14.77. CONNECTOR COMPOSITES (3204/3204M), (3205M/3205F), (3206M), (3300/3300M), (3400), (3410), P. 64.....	306
14.78. CONNECTOR COMPOSITES (4101), (4200), (4201), (4202), (4203), (4204), P. 65.....	307
14.79. CONNECTOR COMPOSITES (4328), (4500), (4705), (4706), P. 65A.....	308
14.80. CONNECTOR COMPOSITES (5000/5000A), P. 66.....	309
14.81. CONNECTOR COMPOSITES (5000), P. 67.....	310
14.82. CONNECTOR COMPOSITES (5001), P. 68.....	311
14.83. CONNECTOR COMPOSITES (5001), P. 68A.....	312
14.84. CONNECTOR COMPOSITES (5003), (5005), (5006), (5007), P. 69.....	313
14.85. CONNECTOR COMPOSITES (5007), P. 69A.....	314
14.86. CONNECTOR COMPOSITES (5009), (5010), (5011M/5011F), P. 69B.....	315
14.87. CONNECTOR COMPOSITES (5012), (5013), (5014), (5015), (5020), (5031), P. 70.....	316
14.88. CONNECTOR COMPOSITES (5033), (5034), (5035/5035A), (5100), (5101), P. 70A.....	317
14.89. CONNECTOR COMPOSITES (5102), (5103), (5104), (5105), P. 71.....	318
14.90. CONNECTOR COMPOSITES (5106), (5107), (5109), (5110), (5111), P. 72.....	319
14.91. CONNECTOR COMPOSITES (5117), (5118), (5119), P. 73.....	320
14.92. CONNECTOR COMPOSITES (5123), (5124), (5125), P. 74.....	321
14.93. CONNECTOR COMPOSITES (5126), (5127), (5128), (5129), (5130), P. 75.....	322

---

14.94. CONNECTOR COMPOSITES (5130), (5134), P. 75A.....	323
14.95. CONNECTOR COMPOSITES (5131), (5134), (5135), (5135M), (5136), (5200), (5201), P. 76.....	324
14.96. CONNECTOR COMPOSITES (5202), (5210), (5212), (5213), P. 77.....	325
14.97. CONNECTOR COMPOSITES (5214), (5215), (5216), (5217), (5218), (5219), P. 78.....	326
14.98. CONNECTOR COMPOSITES (5220), (5222), (5230), P. 78A.....	327
14.99. CONNECTOR COMPOSITES (5232), (5233), (5234), P. 79.....	328
14.100. CONNECTOR COMPOSITES (5300), (5301), (5302), (5303), P. 79A.....	329
14.101. CONNECTOR COMPOSITES (5312), (5313), (5314), (5500), (5502), (5600), P. 80.....	330
14.102. CONNECTOR COMPOSITES (5601M), (5602F), (5602M), (5603M), (5700), P. 80A.....	331
14.103. CONNECTOR COMPOSITES (5701), (5702), (5752), (5753), (5754), P. 81.....	332
14.104. CONNECTOR COMPOSITES (5757), (5758), (5803), (5900), (5902), (5903), P. 82.....	333
14.105. CONNECTOR COMPOSITES (5904/5904M), (5905/5905F), P. 83.....	334
14.106. CONNECTOR COMPOSITES (5906), (5907), P. 83A.....	335
14.107. CONNECTOR COMPOSITES (5909), (5925/5926), (5927), (5930M), (5940), P. 83B.....	336
14.108. CONNECTOR COMPOSITE (6000), P. 84.....	337
14.109. CONNECTOR COMPOSITE (6010), P. 84A.....	338
14.110. CONNECTOR COMPOSITES (6001), (6018), (6019), P. 85.....	339
14.111. CONNECTOR COMPOSITES (6020), (6021), (6033), P. 85A.....	340
14.112. CONNECTOR COMPOSITES (6200), (6201), (6202), (6260VH), (6260VL), (6260VM), (6304), (6316M), P. 85B.....	341
14.113. CONNECTOR COMPOSITES (6400), (6401), (6402), (6403), (6406/6402), P. 86.....	342
14.114. CONNECTOR COMPOSITES (6420), (6550), (6551), (6561), (6650), (6700), (6701), P. 86A.....	343
14.115. CONNECTOR COMPOSITES (6702), (6703), (6703/6703A), (6704), (6704A), P. 87.....	344
14.116. CONNECTOR COMPOSITES (6705), (6706), (6707), P. 88.....	345
14.117. CONNECTOR COMPOSITES (6708), (6709), (6712), (6713), (6714), P. 88A.....	346
14.118. CONNECTOR COMPOSITES (6715), (6716), (6716A), (6720/6721), (6730), P. 88B.....	347
14.119. CONNECTOR COMPOSITES (6725), (6731/6731A), P. 88C.....	348
14.120. CONNECTOR COMPOSITES (6732), (7103), (7104), P. 89.....	349
14.121. CONNECTOR COMPOSITES (7105), (7107/7110), (7111), (7500/7500A), P. 90.....	350
14.122. CONNECTOR COMPOSITES (7500W), (7600), (7600A), (7616), P. 91.....	351
14.123. CONNECTOR COMPOSITES (7617), (7700/7700L/7700K), (7802), (7905), P. 91A.....	352
14.124. CONNECTOR COMPOSITES (8000), (8001), (8001/8001F), P. 92.....	353
14.125. CONNECTOR COMPOSITES (8002), (8003), (8006R), (8006T), (8050), (8051), P. 93.....	354
14.126. CONNECTOR COMPOSITES (8052), (8053), (8100), (8100A), (8100B), P. 93A.....	355
14.127. CONNECTOR COMPOSITES (8101), (8101A), (8101B), (8102), (8103), (8104), P. 94.....	356
14.128. CONNECTOR COMPOSITES (8165), (8166), (8166T), (8200), (8201), (8203), P. 95.....	357
14.129. CONNECTOR COMPOSITES (8303), (8310), (8311), (8312), P. 96.....	358
14.130. CONNECTOR COMPOSITES (8350), (8351), (8352), (8410), (8450), P. 97.....	359
14.131. CONNECTOR COMPOSITES (8450A), (8450B), (8451), (8453), (8454), (8455), (8456), (8500), P. 98.....	360
14.132. CONNECTOR COMPOSITES (8501), (8502), (8503), (8504), P. 99.....	361
14.133. CONNECTOR COMPOSITES (8505), (8506), (8507), (8550), P. 100.....	362
14.134. CONNECTOR COMPOSITES (8601), (8750), (8800), (8802), P. 101.....	363
14.135. CONNECTOR COMPOSITES (8803), (8804), (8805), (8806), P. 102.....	364
14.136. CONNECTOR COMPOSITES (8900), (8901), (8902), (8950), (8951), P. 103.....	365
14.137. CONNECTOR COMPOSITES (8952), (8953/8954M/8953F), P. 104.....	366
14.138. CONNECTOR COMPOSITES (8954), (8954M), (8960), (8961), (8962), P. 105.....	367
14.139. CONNECTOR COMPOSITES (8963), (8964), (8965), (8966), (8967), P. 106.....	368
14.140. CONNECTOR COMPOSITES (8970), (8971), (8972), (8973), P. 107.....	369
14.141. CONNECTOR COMPOSITES (8974), (8975), (8976), (8977), P. 108.....	370
14.142. CONNECTOR COMPOSITES (8980), (8981), (8982), (8983), (8984), P. 109.....	371

---

---

14.143. CONNECTOR COMPOSITES (8990), (9100/9100A/9100B/9100C), (9102/9102A) (9103), (9303A/9303E/9303D), P. 110.....	372
14.144. CONNECTOR COMPOSITES (9303/9303C/9303B), (9304A), (9305/9305A), P. 111.....	373
14.145. CONNECTOR COMPOSITES (9501), (9501D), (9502/9502A), (9502B), (9503/9503D), (9504/9504A/9504B), P. 112.....	374
14.146. CONNECTOR COMPOSITES (9505/9505A), (9506/9506D/9506E), (9507/9507A/9507B), (9508/9508B/9508D/9508E), (9509/9509A/9509B), P. 113.....	375
14.147. CONNECTOR COMPOSITES (9510/9510A/9510F), (9510F/9510M), (9511), (9511/9511A), (9512), P. 114.....	376
14.148. CONNECTOR COMPOSITES (9512), (9513), (9514), (9515/9515A/9515B), P. 115.....	377
14.149. CONNECTOR COMPOSITES (9516M), (9635), (9715F/9715M), P. 116.....	378
14.150. CONNECTOR COMPOSITES (9716M/9716F), (9718), (9736), (9737), P. 117.....	379
14.151. CONNECTOR COMPOSITES (9738), (9768), (9769), P. 118.....	380
14.152. CONNECTOR COMPOSITES (9770), (9779/9779F/9779FA), (9779F1), (9780/9780M), (9780M1), P. 119.....	381
14.153. CONNECTOR COMPOSITES (9781F), (9782M), (9783F), (9783M), (9784M), P. 120.....	382
14.154. CONNECTOR COMPOSITES (9789/9789F/9789FA), (9790/9790M/9790MA), P. 121.....	383
14.155. CONNECTOR COMPOSITES (9800/9800F/9800M), P. 122.....	384
14.156. CONNECTOR COMPOSITES (9801/9801F/9801M), P. 123.....	385
14.157. CONNECTOR COMPOSITES (9811), (9812), (9813), P. 124.....	386
14.158. CONNECTOR COMPOSITES (9814), (9815), (9816), P. 125.....	387
14.159. CONNECTOR COMPOSITES (9830/9832), (9865/9865F/9865M), P. 126.....	388
14.160. CONNECTOR COMPOSITES (9900), (9901), (9902), P. 127.....	389
15. SUPPLEMENT FOR CUMMINS EPA98 ISX ENGINE (PROSTAR ONLY).....	390
15.1. ELECTRONIC ENGINE CONTROLS — CUMMINS EPA98 ISX (PROSTAR ONLY), P. 2.....	390
15.2. ELECTRONIC ENGINE CONTROLS — CUMMINS EPA98 ISX (PROSTAR ONLY), P. 3.....	391
15.3. CONNECTOR COMPOSITES (1091), (PROSTAR ONLY), P. 4.....	392
15.4. CONNECTOR COMPOSITES (1093), (1155), (PROSTAR ONLY), P. 5.....	393



1. TABLE OF CONTENTS (CHAPTER 1)

2. INSTRUCTIONS AND CHARTS (CHAPTER 2)

2.1. ABBREVIATIONS, P. 1

INTERNATIONAL TRUCK AND ENGINE CORPORATION				ELECTRICAL CIRCUIT DIAGRAM		CHAPTER 2	
THIS PRINT IS PROVIDED ON A RESTRICTED BASIS AND IS NOT TO BE USED IN ANY WAY DETRIMENTAL TO THE INTEREST OF INTERNATIONAL TRUCK AND ENGINE CORPORATION.				ABBREVIATIONS			
ACCESS	ACCESSORY	CUR	CURRENT	PRESS	PRESSURE		
AC	AIR CONDITIONING	DPNL	DASHBOARD	RAD	RADIO		
AIR CLNR	AIR CLEANER	DFTR	DEFLECTOR	RR	REAR		
ALT	ALTERNATOR	DFR	DEFROSTER	RLY	RELAY		
AC	ALTERNATING CURRENT	DEG	DEGREE	RES	RESISTOR		
AFTR	AFTERTREATMENT	DIAG	DIAGRAM	R	RIGHT		
AMM	AMMETER	DSL	DIESEL	RTR	ROTOR		
AMP	AMPERE	DIFF	DIFFERENTIAL	SNSR	SENSOR		
AMP HR	AMPERE HOUR	DIMR	DIMMER	SHLD	SHIELD		
AMPL	AMPLIFIER	ELEC	ELECTRICAL	SHFT	SHIFTER		
ARM	ARMATURE	ELEX	ELECTRONICS	SLPR	SLEEPER		
ARSR	ARRESTER	ENG	ENGINE	SLV	SLEEVE		
ASSY	ASSEMBLY	EXH	EXHAUST	SPKR	SPEAKER		
AUX	AUXILIARY	FL	FLUID	SPR	SPRING		
B/U	BACK-UP	FWD	FORWARD	STD	STANDARD		
BTRY	BATTERY	FR	FRONT	STRG	STEERING		
BM	BENCHMARKING	FREQ	FREQUENCY	STLITE	SATELLITE		
BLK	BLOCK	GA	GAUGE	SUNSH	SUNSHADE		
BOOS	BOOSTER	GEN	GENERATOR	SW	SWITCH		
BOT	BOTTOM	GND	GROUND	SYS	SYSTEM		
BK	BRAKE	HARN	HARNESS	TACH	TACHOMETER		
BRKR	BREAKER	HDLP	HEADLAMP	TEMP	TEMPERATURE		
BRTHR	BREATHER	HTD	HEATED	TERM	TERMINAL		
BRI	BRIGHT	HT TR	HEAT TREAT	THROT	THROTTLE		
BUZ	BUZZER	HTR	HEATER	THRU	THROUGH		
CA	CABLE	HP	HORSEPOWER	TRLR	TRAILER		
CD	CANDELA	HYD	HYDRAULIC	XDCR	TRANSDUCER		
CP	CANDLEPOWER	ID	IDENTIFICATION	XFER	TRANSFER		
CAP	CAPACITOR	IGN	IGNITION	XFMR	TRANSFORMER		
CAT	CATERPILLAR	ILLUM	ILLUMINATION	XSTR	TRANSISTOR		
CHAS	CHASSIS	IND	INDICATOR	XMSN	TRANSMISSION		
CH	CHOKE	INST	INSTRUMENT	XMTR	TRANSMITTER		
CIRC	CIRCUIT	INT	INTERMITTENT	TRK	TRUCK		
CLK	CLOCK	L	LEFT	UPR	UPPER		
CW	CLOCKWISE	LT	LIGHT	VLV	VALVE		
CLSTR	CLUSTER	LTR	LIGHTER	VERT	VERTICAL		
CL	CLUTCH	LWR	LOWER	VM	VOLTMETER		
COL	COLUMN	MAG	MAGNET	VOL	VOLUME		
COMM	COMMUTATOR	MOD	MODULATOR	WSHR	WASHER		
CMPNT	COMPONENT	MDL	MODULE	WHL	WHEEL		
CPRSR	COMPRESSOR	MOT	MOTOR	WDO	WINDOW		
CONN	CONNECT	MTD	MOUNTED	WSHLD	WINDSHIELD		
CONT	CONTINUED	NEG	NEGATIVE	WPR	WIPER		
CSL	CONSOLE	N/	NOT WITH	W/	WITH		
CONT	CONTACT	NO.	NUMBER	W/O	WITHOUT		
CONT	CONTROL	PASS	PASSENGER				
CONV	CONVERTER	POSN	POSITION				
CLR	COOLER	POS	POSITIVE				
CTSY	COURTESY	POT	POTENTIOMETER				
CRUS	CRUISE	PWR	POWER				

CHK	DATE	CHANGE	REV	REFERENCE	DRAWN	NAME	
CNA1	14JAN09	TITLE WAS CIRCUIT	B	61254R	U00K640	CIRCUIT DIAGRAM, PROSTAR, LONESTAR	
	DIAGRAM, PROSTAR				RELEASE NO. 59637L	DATE 31AUG06	PART NO. AE08055894 SHEET 001

Figure 1 Abbreviations

2.2. ACRONYMS, P. 2

INTERNATIONAL TRUCK AND ENGINE CORPORATION		ELECTRICAL CIRCUIT DIAGRAM		CHAPTER 2																																																																																																																																			
THIS PRINT IS PROVIDED ON A RESTRICTED BASIS AND IS NOT TO BE USED IN ANY WAY DETRIMENTAL TO THE INTEREST OF INTERNATIONAL TRUCK AND ENGINE CORPORATION.		ACRONYMS																																																																																																																																					
<table border="1" style="width: 100%; border-collapse: collapse;"> <thead> <tr> <th style="width: 50%;">DESCRIPTION</th> <th style="width: 50%;">ACRONYM</th> </tr> </thead> <tbody> <tr><td>ANTILOCK BRAKING SYSTEM</td><td>ABS</td></tr> <tr><td>ANTENNA COMMUNICATION UNIT</td><td>ACU</td></tr> <tr><td>ALTERNATING CURRENT</td><td>AC</td></tr> <tr><td>AXLE TO BACK OF CAB</td><td>AC</td></tr> <tr><td>AXLE TO FRAME</td><td>AF</td></tr> <tr><td>ACCELERATOR PEDAL MODULE</td><td>APM</td></tr> <tr><td>ACCELERATOR POSITION SENSOR</td><td>APS</td></tr> <tr><td>AUXILIARY POWER UNIT</td><td>APU</td></tr> <tr><td>AUTOMATIC TRACTION CONTROL</td><td>ATC</td></tr> <tr><td>AUDIO VIDEO INTERFACE</td><td>AVI</td></tr> <tr><td>BRAKE HORSEPOWER</td><td>BHP</td></tr> <tr><td>BACK OF CAB</td><td>BOC</td></tr> <tr><td>CITIZEN BAND</td><td>CB</td></tr> <tr><td>COLD CRANKING AMPERES</td><td>CCA</td></tr> <tr><td>CLEAN POWER ELECTRICAL CONNECTOR</td><td>CEC</td></tr> <tr><td>CAB OVER ENGINE</td><td>COE</td></tr> <tr><td>DIRECT CURRENT</td><td>DC</td></tr> <tr><td>DRIVER CONTROL MODULE</td><td>DCM</td></tr> <tr><td>DIGITAL DATA LINK</td><td>DDL</td></tr> <tr><td>DIESEL OXIDATION CATALYST INLET TEMPERATURE</td><td>DOCT</td></tr> <tr><td>DIESEL PARTICULATE FILTER</td><td>DPF</td></tr> <tr><td>DIESEL TURBOCHARGED</td><td>DT</td></tr> <tr><td>DAY TIME RUNNING LIGHTS</td><td>DTRL</td></tr> <tr><td>ELECTRONIC CONTROL MODULE</td><td>ECM</td></tr> <tr><td>ELECTRONIC CONTROL UNIT</td><td>ECU</td></tr> <tr><td>EXHAUST GAS RECIRCULATION</td><td>EGR</td></tr> <tr><td>EXHAUST GAS TEMPERATURE</td><td>EGT</td></tr> <tr><td>ELECTRO MAGNETIC INTERFACE</td><td>EMI</td></tr> <tr><td>END OF FRAME</td><td>EOF</td></tr> <tr><td>ELECTRIC TRAILER BRAKE</td><td>ETB</td></tr> <tr><td>FRONT AXLE</td><td>FA</td></tr> <tr><td>FRONT END</td><td>FE</td></tr> <tr><td>FRONT OF DASH</td><td>FOD</td></tr> <tr><td>FULL POWER BRAKE</td><td>FPB</td></tr> <tr><td>GLOBAL POSITIONING SYSTEM</td><td>GPS</td></tr> <tr><td>HYDRAULIC CONTROL UNIT</td><td>HCU</td></tr> <tr><td>HEAVY DUTY</td><td>HD</td></tr> <tr><td>HEAVY DUTY DIESEL</td><td>HDD</td></tr> <tr><td>HIGH PERFORMANCE TRUCK</td><td>HPT</td></tr> <tr><td>HEATING, VENTILATION, AND AIR CONDITIONING</td><td>HVAC</td></tr> </tbody> </table> <table border="1" style="width: 100%; border-collapse: collapse; margin-top: 10px;"> <thead> <tr> <th style="width: 50%;">DESCRIPTION</th> <th style="width: 50%;">ACRONYM</th> </tr> </thead> <tbody> <tr><td>INJECTOR DRIVE MODULE</td><td>IDM</td></tr> <tr><td>INPUT/OUTPUT</td><td>I/O</td></tr> <tr><td>INTEGRATED MOBILE COMMUNICATIONS TERMINAL</td><td>IMCT</td></tr> <tr><td>INSTRUMENT PANEL</td><td>I/P</td></tr> <tr><td>INDEPENDENT POWER TAKE-OFF</td><td>IPTO</td></tr> <tr><td>LIGHT COMMERCIAL TRANSMISSION</td><td>LCT</td></tr> <tr><td>MEDIUM DUTY</td><td>MD</td></tr> <tr><td>MALFUNCTION INDICATION LAMP</td><td>MIL</td></tr> <tr><td>MULTIPLEX SWITCH MODULE</td><td>MSM</td></tr> <tr><td>PYROMETER AMMETER MODULE</td><td>PAM</td></tr> <tr><td>PROGRAMMABLE LOGIC CONTROLLER</td><td>PLC</td></tr> <tr><td>POWER TAKE-OFF</td><td>PTO</td></tr> <tr><td>PULSE WIDTH MODULATION</td><td>PWM</td></tr> <tr><td>REAR AXLE</td><td>RA</td></tr> <tr><td>RADIO FREQUENCY</td><td>RF</td></tr> <tr><td>ROLL STABILITY PROGRAMM</td><td>RSP</td></tr> <tr><td>SEVERE SERVICE</td><td>SS</td></tr> <tr><td>TRANSMISSION CONTROL MODULE</td><td>TCM</td></tr> <tr><td>TERRESTRIAL COMMUNICATION UNIT</td><td>TCU</td></tr> <tr><td>TERRESTRIAL MOBILE COMMUNICATIONS TERMINAL</td><td>TMCT</td></tr> <tr><td>THERMAL OVERCRANK PROTECTION</td><td>TOCP</td></tr> <tr><td>THROTTLE POSITION SENSOR</td><td>TPS</td></tr> <tr><td>ZERO VOLT REFERENCE</td><td>ZVR</td></tr> </tbody> </table>						DESCRIPTION	ACRONYM	ANTILOCK BRAKING SYSTEM	ABS	ANTENNA COMMUNICATION UNIT	ACU	ALTERNATING CURRENT	AC	AXLE TO BACK OF CAB	AC	AXLE TO FRAME	AF	ACCELERATOR PEDAL MODULE	APM	ACCELERATOR POSITION SENSOR	APS	AUXILIARY POWER UNIT	APU	AUTOMATIC TRACTION CONTROL	ATC	AUDIO VIDEO INTERFACE	AVI	BRAKE HORSEPOWER	BHP	BACK OF CAB	BOC	CITIZEN BAND	CB	COLD CRANKING AMPERES	CCA	CLEAN POWER ELECTRICAL CONNECTOR	CEC	CAB OVER ENGINE	COE	DIRECT CURRENT	DC	DRIVER CONTROL MODULE	DCM	DIGITAL DATA LINK	DDL	DIESEL OXIDATION CATALYST INLET TEMPERATURE	DOCT	DIESEL PARTICULATE FILTER	DPF	DIESEL TURBOCHARGED	DT	DAY TIME RUNNING LIGHTS	DTRL	ELECTRONIC CONTROL MODULE	ECM	ELECTRONIC CONTROL UNIT	ECU	EXHAUST GAS RECIRCULATION	EGR	EXHAUST GAS TEMPERATURE	EGT	ELECTRO MAGNETIC INTERFACE	EMI	END OF FRAME	EOF	ELECTRIC TRAILER BRAKE	ETB	FRONT AXLE	FA	FRONT END	FE	FRONT OF DASH	FOD	FULL POWER BRAKE	FPB	GLOBAL POSITIONING SYSTEM	GPS	HYDRAULIC CONTROL UNIT	HCU	HEAVY DUTY	HD	HEAVY DUTY DIESEL	HDD	HIGH PERFORMANCE TRUCK	HPT	HEATING, VENTILATION, AND AIR CONDITIONING	HVAC	DESCRIPTION	ACRONYM	INJECTOR DRIVE MODULE	IDM	INPUT/OUTPUT	I/O	INTEGRATED MOBILE COMMUNICATIONS TERMINAL	IMCT	INSTRUMENT PANEL	I/P	INDEPENDENT POWER TAKE-OFF	IPTO	LIGHT COMMERCIAL TRANSMISSION	LCT	MEDIUM DUTY	MD	MALFUNCTION INDICATION LAMP	MIL	MULTIPLEX SWITCH MODULE	MSM	PYROMETER AMMETER MODULE	PAM	PROGRAMMABLE LOGIC CONTROLLER	PLC	POWER TAKE-OFF	PTO	PULSE WIDTH MODULATION	PWM	REAR AXLE	RA	RADIO FREQUENCY	RF	ROLL STABILITY PROGRAMM	RSP	SEVERE SERVICE	SS	TRANSMISSION CONTROL MODULE	TCM	TERRESTRIAL COMMUNICATION UNIT	TCU	TERRESTRIAL MOBILE COMMUNICATIONS TERMINAL	TMCT	THERMAL OVERCRANK PROTECTION	TOCP	THROTTLE POSITION SENSOR	TPS	ZERO VOLT REFERENCE	ZVR
DESCRIPTION	ACRONYM																																																																																																																																						
ANTILOCK BRAKING SYSTEM	ABS																																																																																																																																						
ANTENNA COMMUNICATION UNIT	ACU																																																																																																																																						
ALTERNATING CURRENT	AC																																																																																																																																						
AXLE TO BACK OF CAB	AC																																																																																																																																						
AXLE TO FRAME	AF																																																																																																																																						
ACCELERATOR PEDAL MODULE	APM																																																																																																																																						
ACCELERATOR POSITION SENSOR	APS																																																																																																																																						
AUXILIARY POWER UNIT	APU																																																																																																																																						
AUTOMATIC TRACTION CONTROL	ATC																																																																																																																																						
AUDIO VIDEO INTERFACE	AVI																																																																																																																																						
BRAKE HORSEPOWER	BHP																																																																																																																																						
BACK OF CAB	BOC																																																																																																																																						
CITIZEN BAND	CB																																																																																																																																						
COLD CRANKING AMPERES	CCA																																																																																																																																						
CLEAN POWER ELECTRICAL CONNECTOR	CEC																																																																																																																																						
CAB OVER ENGINE	COE																																																																																																																																						
DIRECT CURRENT	DC																																																																																																																																						
DRIVER CONTROL MODULE	DCM																																																																																																																																						
DIGITAL DATA LINK	DDL																																																																																																																																						
DIESEL OXIDATION CATALYST INLET TEMPERATURE	DOCT																																																																																																																																						
DIESEL PARTICULATE FILTER	DPF																																																																																																																																						
DIESEL TURBOCHARGED	DT																																																																																																																																						
DAY TIME RUNNING LIGHTS	DTRL																																																																																																																																						
ELECTRONIC CONTROL MODULE	ECM																																																																																																																																						
ELECTRONIC CONTROL UNIT	ECU																																																																																																																																						
EXHAUST GAS RECIRCULATION	EGR																																																																																																																																						
EXHAUST GAS TEMPERATURE	EGT																																																																																																																																						
ELECTRO MAGNETIC INTERFACE	EMI																																																																																																																																						
END OF FRAME	EOF																																																																																																																																						
ELECTRIC TRAILER BRAKE	ETB																																																																																																																																						
FRONT AXLE	FA																																																																																																																																						
FRONT END	FE																																																																																																																																						
FRONT OF DASH	FOD																																																																																																																																						
FULL POWER BRAKE	FPB																																																																																																																																						
GLOBAL POSITIONING SYSTEM	GPS																																																																																																																																						
HYDRAULIC CONTROL UNIT	HCU																																																																																																																																						
HEAVY DUTY	HD																																																																																																																																						
HEAVY DUTY DIESEL	HDD																																																																																																																																						
HIGH PERFORMANCE TRUCK	HPT																																																																																																																																						
HEATING, VENTILATION, AND AIR CONDITIONING	HVAC																																																																																																																																						
DESCRIPTION	ACRONYM																																																																																																																																						
INJECTOR DRIVE MODULE	IDM																																																																																																																																						
INPUT/OUTPUT	I/O																																																																																																																																						
INTEGRATED MOBILE COMMUNICATIONS TERMINAL	IMCT																																																																																																																																						
INSTRUMENT PANEL	I/P																																																																																																																																						
INDEPENDENT POWER TAKE-OFF	IPTO																																																																																																																																						
LIGHT COMMERCIAL TRANSMISSION	LCT																																																																																																																																						
MEDIUM DUTY	MD																																																																																																																																						
MALFUNCTION INDICATION LAMP	MIL																																																																																																																																						
MULTIPLEX SWITCH MODULE	MSM																																																																																																																																						
PYROMETER AMMETER MODULE	PAM																																																																																																																																						
PROGRAMMABLE LOGIC CONTROLLER	PLC																																																																																																																																						
POWER TAKE-OFF	PTO																																																																																																																																						
PULSE WIDTH MODULATION	PWM																																																																																																																																						
REAR AXLE	RA																																																																																																																																						
RADIO FREQUENCY	RF																																																																																																																																						
ROLL STABILITY PROGRAMM	RSP																																																																																																																																						
SEVERE SERVICE	SS																																																																																																																																						
TRANSMISSION CONTROL MODULE	TCM																																																																																																																																						
TERRESTRIAL COMMUNICATION UNIT	TCU																																																																																																																																						
TERRESTRIAL MOBILE COMMUNICATIONS TERMINAL	TMCT																																																																																																																																						
THERMAL OVERCRANK PROTECTION	TOCP																																																																																																																																						
THROTTLE POSITION SENSOR	TPS																																																																																																																																						
ZERO VOLT REFERENCE	ZVR																																																																																																																																						
CHK	DATE	CHANGE	REV	REFERENCE	DRAWN	NAME																																																																																																																																	
CNA1	14JAN09	TITLE WAS CIRCUIT	B	61254R	U00K640	CIRCUIT DIAGRAM, PROSTAR, LONESTAR																																																																																																																																	
		DIAGRAM, PROSTAR			59637L	DATE: 31AUG06 PART NO: AE08055894 SHEET: 002																																																																																																																																	

Figure 2 Acronyms

2.3. CIRCUIT DIAGRAM INSTRUCTIONS, P. 3

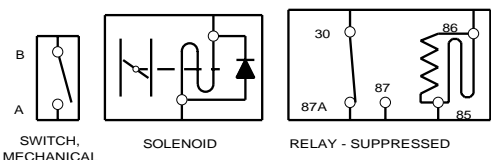
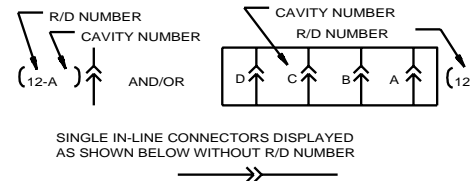
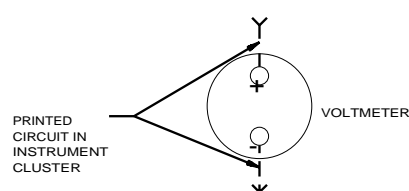
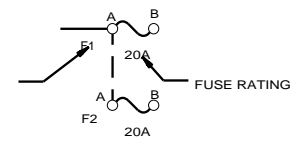
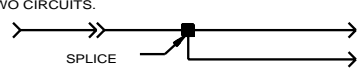
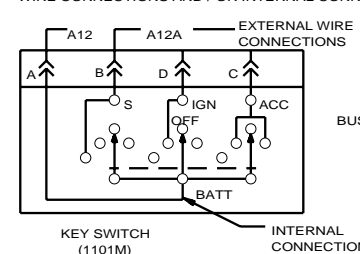
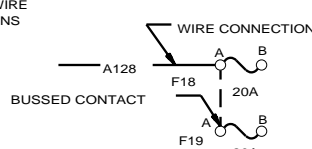
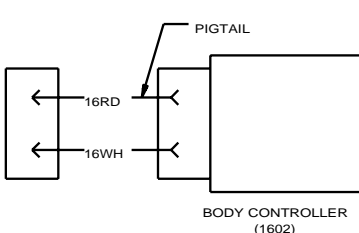
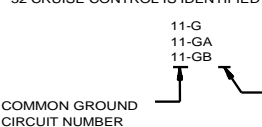
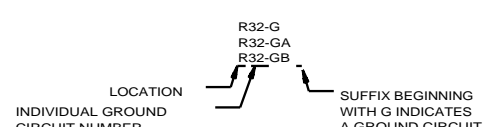
INTERNATIONAL TRUCK AND ENGINE CORPORATION		ELECTRICAL CIRCUIT DIAGRAM		CHAPTER 2		
THIS PRINT IS PROVIDED ON A RESTRICTED BASIS AND IS NOT TO BE USED IN ANY WAY DETRIMENTAL TO THE INTEREST OF INTERNATIONAL TRUCK AND ENGINE CORPORATION.			CIRCUIT DIAGRAM INSTRUCTIONS			
<p>A - SWITCH AND RELAY POSITIONS AS SHOWN ON CIRCUIT DIAGRAMS INDICATE NORMAL POSITION WITH IGNITION OFF UNLESS OTHERWISE NOTED.</p>			<p>B - MULTIPLE CONNECTIONS ARE DISPLAYED ON SCHEMATIC AS SHOWN WITH R/D NUMBER &amp; CAVITY NUMBER. REFER TO CONNECTOR COMPOSITE FOR MORE INFORMATION</p>			
 <p>SWITCH, MECHANICAL      SOLENOID      RELAY - SUPPRESSED</p>			 <p>SINGLE IN-LINE CONNECTORS DISPLAYED AS SHOWN BELOW WITHOUT R/D NUMBER</p>			
<p>C - PHANTOM LINES INDICATE PRINTED CIRCUITS OR BUSSED CIRCUITS. THESE CIRCUITS EXIST IN THE INSTRUMENT CLUSTER AND FUSE / CIRCUIT BREAKER CONNECTORS.</p>						
 <p>PRINTED CIRCUIT IN INSTRUMENT CLUSTER      VOLTMETER</p>		<p>LOCATION / CIRCUIT NUMBER WIRE GAUGE / WIRE COLOR</p>		 <p>LOCATION IN FUSE / CIRCUIT BREAKER CONNECTION      FUSE RATING</p>		
<p>D - MULTIPLE CIRCUIT NUMBERS ON A LINE INDICATE ONE CIRCUIT DISTRIBUTING CURRENT TO TWO CIRCUITS.</p>						
 <p>SPLICE</p>						
<p>E - SWITCHES, RELAYS AND COMPONENTS INDICATE EXTERNAL WIRE CONNECTIONS AND / OR INTERNAL CONNECTIONS OR CONTACTS.</p>						
 <p>KEY SWITCH (1101M)      INTERNAL CONNECTION</p>		 <p>BUSED CONTACT      WIRE CONNECTION</p>		 <p>PIGTAIL      BODY CONTROLLER (1602)</p>		
<p>F - CIRCUIT "11" DENOTES ANY COMMON GROUND (MORE THAN ONE CIRCUIT). ANY INDIVIDUAL GROUND CIRCUIT IS IDENTIFIED WITH THAT PARTICULAR CIRCUIT NUMBER. (E.G. CIRCUIT 32 CRUISE CONTROL IS IDENTIFIED AS PER EXAMPLE)</p>						
 <p>COMMON GROUND CIRCUIT NUMBER</p>		 <p>INDIVIDUAL GROUND CIRCUIT NUMBER</p>		<p>SUFFIX BEGINNING WITH G INDICATES A GROUND CIRCUIT</p>		
<p>NOTE: FOR CIRCUIT DESCRIPTION OTHER THAN GROUNDS NEITHER THE LETTER "G" NOR THE COLOR WHITE SHALL BE USED</p>						
CHK	DATE	CHANGE	REV	REFERENCE	DRAWN	NAME
CNA1	14JAN09	TITLE WAS CIRCUIT	B	61254R	U00K640	CIRCUIT DIAGRAM, PROSTAR, LONESTAR
		DIAGRAM, PROSTAR			59637L	
					RELEASE NO.	DATE
					59637L	31AUG06
					PART NO.	SHEET
					AE08055894	003

Figure 3 Circuit Diagram Instructions

LoneStar® and ProStar® Chassis Built January, 2007 and After — ELECTRICAL  
CIRCUIT DIAGRAMS

2.4. CIRCUIT NUMBER IDENTIFICATION AND COLOR, P. 4

INTERNATIONAL TRUCK AND ENGINE CORPORATION		ELECTRICAL CIRCUIT DIAGRAM	CHAPTER 2
THIS PRINT IS PROVIDED ON A RESTRICTED BASIS AND IS NOT TO BE USED IN ANY WAY DETRIMENTAL TO THE INTEREST OF INTERNATIONAL TRUCK AND ENGINE CORPORATION.		CIRCUIT NUMBER IDENTIFICATION AND COLOR	
CIRCUIT NUMBER	COLOR	DESCRIPTION	
1	LTBL	ALTERNATOR - FIELD	
2	RD	ALTERNATOR - CHARGE	
3	DKBL	SERIAL / DATA COMMUNICATION J1587 / J1708 (+)	
	GY	SERIAL / DATA COMMUNICATION J1587 / J1708 (-)	
4	DKBL	SERIAL / DATA COMMUNICATION J1922 (+)	
	GY	SERIAL / DATA COMMUNICATION J1922 (-)	
5	YL	SERIAL / DATA COMMUNICATION J1939/11 / J1939/15 (+)	
	GN	SERIAL / DATA COMMUNICATION J1939/11 / J1939/15 (-)	
	GY	LOW VOLTAGE ELECTRONIC FEED (LESS THAN 9 VOLTS)	
7	RD	ALTERNATOR - RESISTANCE	
8			
9	GY	LOW VOLTAGE ELECTRONIC GROUND	
10	WH	CHASSIS / ENGINE GROUND	
11	WH	CAB / SLEEPER GROUND	
12	LTBL	ACCESSORY FEED	
13	PK	IGNITION FEED	
	BK	IGNITION FEED (BODY BUILDER CONNECTOR)	
14	RD	BATTERY FEED	
15	RD	KEY SWITCH FEED	
16			
17	PK	STARTER CONTROL	
18	PK	GLOW PLUG / PREHEATER	
19	GY	ENGINE SHUTDOWN	
20	LTGN	REMOTE POWER MODULE	
21	TN	COLD START CONTROLS (ETHER)	
22	TN	TIRE PRESSURE MONITORING / CONTROL	
23	TN	ENGINE FAN / SHUTTERS	
24	GY	ENGINE EXHAUST BRAKE	
25	TN	PYROMETER	
26	TN	AMMETER	
27	TN	VOLTMETER	
28	TN	INSTRUMENTS AND GAUGES	
29	TN	ENGINE WATER TEMPERATURE	
30	TN	ENGINE OIL TEMPERATURE	
31	TN	TRANSMISSION OIL TEMPERATURE	
32	TN	AXLE OIL TEMPERATURE	
33	TN	ENGINE OIL LEVEL	
34	TN	COOLANT LEVEL	
35	TN	ENGINE OIL PRESSURE	
36	TN	FUEL LEVEL	
37	TN	FUEL PUMP	
38	GY	LIFT AXLE	
39	GY	AIR DRYER HEATER	
40	GY	LOW AIR PRESSURE WARNING	

CHK	DATE	CHANGE	REV	REFERENCE	DRAWN	NAME
CNA1	20JAN09	TITLE WAS CIRCUIT	B	61254R	U00K640	CIRCUIT DIAGRAM, PROSTAR, LONESTAR
		DIAGRAM, PROSTAR			59637L	DATE: 31AUG06 PART NO: AE08055894 SHEET: 004

Figure 4 Circuit Number Identification and Color

2.5. CIRCUIT NUMBER IDENTIFICATION AND COLOR (CONT.), P. 5

INTERNATIONAL TRUCK AND ENGINE CORPORATION		ELECTRICAL CIRCUIT DIAGRAM		CHAPTER 2	
THIS PRINT IS PROVIDED ON A RESTRICTED BASIS AND IS NOT TO BE USED IN ANY WAY DETRIMENTAL TO THE INTEREST OF INTERNATIONAL TRUCK AND ENGINE CORPORATION.			CIRCUIT NUMBER IDENTIFICATION AND COLOR (CONT)		
CIRCUIT NUMBER	COLOR	DESCRIPTION			
41	TN	AIR TEMPERATURE			
42	GY	FRONT AXLE ENGAGED			
43	GY	POWER DIVIDER LOCK (PDL) WARNING			
44	GY	PARK BRAKE WARNING			
45	LTGN	ANTITHEFT WARNING			
46	GY	POWER TAKEOFF WARNING			
47	GY	SPEEDOMETER			
48	GY	TACHOMETER			
49	GY	DIFFERENTIAL LOCK WARNING			
50	YL	LIGHT SWITCH FEED			
51	YL	DIMMER SWITCH FEED			
52	YL	HEADLIGHT HI - BEAM			
53	YL	HEADLIGHT LO - BEAM			
54	BN	PARKING / MARKER LIGHTS			
55	OR	TURN SIGNAL - FEED			
56	OR	TURN SIGNAL LIGHTS - LEFT			
	YL	TURN SIGNAL LIGHTS - LEFT (BODY BUILDER CONNECTION)			
57	OR	TURN SIGNAL LIGHTS - RIGHT			
	LTGN	TURN SIGNAL LIGHTS - RIGHT (BODY BUILDER CONNECTION)			
58	BN	CLEARANCE / IDENTIFICATION LIGHTS			
59	GY	SOLENOID			
60	OR	HAZARD LIGHTS			
61	GY	AIR SUSPENSION			
62	DKBL	PANEL LIGHTS			
63	DKBL	COURTESY / DOME LIGHTS			
64	YL	FOG / DRIVING LIGHTS			
65	OR	CAB REAR FLOOD LIGHTS			
66	YL	DAYTIME RUNNING LIGHT			
67	GY	OBSTACLE AVOIDANCE / REMOTE SENSOR			
68	BN	TAIL LIGHTS			
69	BN	LICENSE PLATE LIGHT			
70	OR	STOP LIGHTS			
	RD	STOP LIGHTS (BODY BUILDER CONNECTION)			
71	OR	BACKUP - LIGHTS			
	LTBL	BACKUP - LIGHTS (BODY BUILDER CONNECTION)			
72	OR	TRAILER AUXILIARY FEED - BATTERY			
73	LTGN	PWM			
74	LTGN	HEATER RECIRC MOTOR			
75	LTGN	HEATER BLOWER MOTOR			
76	LTGN	AUXILIARY FAN			
77	LTGN	AIR CONDITIONER			
78	LTGN	MIRRORS - HEATED, MOTORIZED			
79	GY	SEAT BELTS			
80	BK	SLEEPER BOX RELAY - FEED			

CHK	DATE	CHANGE	REV	REFERENCE	DRAWN	NAME
CNA1	14JAN09	TITLE WAS CIRCUIT	B	61254R	U00K640	CIRCUIT DIAGRAM, PROSTAR, LONESTAR
		DIAGRAM, PROSTAR			59637L	31AUG06 AE08055894 005

Figure 5 Circuit Number Identification and Color (Cont.)

2.6. CIRCUIT NUMBER IDENTIFICATION AND COLOR (CONT.), P. 6

INTERNATIONAL TRUCK AND ENGINE CORPORATION <small>THIS PRINT IS PROVIDED ON A RESTRICTED BASIS AND IS NOT TO BE USED IN ANY WAY DETRIMENTAL TO THE INTEREST OF INTERNATIONAL TRUCK AND ENGINE CORPORATION.</small>		ELECTRICAL CIRCUIT DIAGRAM    CHAPTER 2 CIRCUIT NUMBER IDENTIFICATION AND COLOR (CONT)																																																																																																																																												
<table border="1" style="width:100%; border-collapse: collapse;"> <thead> <tr> <th style="width:15%;">CIRCUIT NUMBER</th> <th style="width:15%;">COLOR</th> <th style="width:70%;">DESCRIPTION</th> </tr> </thead> <tbody> <tr><td>81</td><td>LTGN</td><td>POWER DOOR LOCKS</td></tr> <tr><td>82</td><td>GY</td><td>WINDSHIELD WIPER</td></tr> <tr><td>83</td><td>LTGN</td><td>POWER WINDOWS</td></tr> <tr><td>84</td><td>LTGN</td><td>CIGAR LIGHTER</td></tr> <tr><td>85</td><td>GY</td><td>HORN</td></tr> <tr><td>86</td><td>LTGN</td><td>RADIO - ENTERTAINMENT / CLOCK</td></tr> <tr><td>87</td><td>GY</td><td>WINDSHIELD WASHER</td></tr> <tr><td>88</td><td>LTGN</td><td>CLOCK / HOURMETER</td></tr> <tr><td>89</td><td>VT</td><td>AIR BAG</td></tr> <tr><td>90</td><td>GY</td><td>HYDRAULIC BRAKE PUMP</td></tr> <tr><td>91</td><td>VT</td><td>INTERCOMMUNICATION</td></tr> <tr><td>92</td><td>TN</td><td>TRANSMISSION CONTROLS - ELECTRONICS</td></tr> <tr><td>93</td><td>TN</td><td>AXLE SHIFT CONTROL</td></tr> <tr><td>94</td><td>GY</td><td>ANTILOCK BRAKE SYSTEM</td></tr> <tr><td>95</td><td>TN</td><td>EXHAUST EMISSION</td></tr> <tr><td>96</td><td>YL</td><td>SNOW PLOW LIGHTS / CRUISE CONTROLS</td></tr> <tr><td>97</td><td>VT</td><td>ENGINE CONTROLS - ELECTRONIC</td></tr> <tr><td>98</td><td>BK</td><td>DATALINK AND DIAGNOSTICS</td></tr> <tr><td>99</td><td>VT</td><td>ACCELERATOR POSITION SENSOR (APS)</td></tr> <tr><td>100</td><td>GY</td><td>AIR HORN (ELECTRIC SOLENOID ACTUATED)</td></tr> <tr><td>101</td><td>TN</td><td>BRAKE APPLICATION AIR</td></tr> <tr><td>102</td><td>YL</td><td>FLASH TO PASS</td></tr> <tr><td>103</td><td>LTGN</td><td>BODY BUILDER AUXILIARY FEED</td></tr> <tr><td>104</td><td>DKBL</td><td>REMOTE START / STOP</td></tr> <tr><td>105</td><td>LTGN</td><td>HEATED SEATS</td></tr> <tr><td>106</td><td>OR</td><td>HIGH VOLTAGE ALTERNATOR AC CHARGE</td></tr> <tr><td>107</td><td>GY</td><td>INTRUMENT CLUSTER ELECTRONIC FEED (5V)</td></tr> <tr><td>108</td><td>GY</td><td>BRAKE PAD WEAR SENSOR</td></tr> <tr><td>109</td><td>GY</td><td>BRAKE STROKE / SLACK ADJUSTER</td></tr> <tr><td>110</td><td>GY</td><td>INTRUMENT CLUSTER ELECTRONIC GROUND</td></tr> <tr><td>111</td><td>TN</td><td>FUEL FILTER RESTRICTION TRANSDUCER</td></tr> <tr><td>112</td><td>GY</td><td>LIFT GATE</td></tr> </tbody> </table> <table border="1" style="width:100%; border-collapse: collapse;"> <thead> <tr> <th style="width:10%;">PREFIX</th> <th style="width:90%;">LOCATION</th> </tr> </thead> <tbody> <tr><td>A</td><td>CAB - INSTRUMENT PANEL MODULE</td></tr> <tr><td>B</td><td>CAB - DRIVER CONTROL MODULE</td></tr> <tr><td>C</td><td>CAB - HEADER / CLEARANCE LIGHTS</td></tr> <tr><td>D</td><td>CAB - ROOF / REAR PANEL</td></tr> <tr><td>E</td><td>CAB - LEFT DOOR / DOORS</td></tr> <tr><td>F</td><td>CAB - RIGHT DOOR / DOORS</td></tr> <tr><td>H</td><td>CAB - SLEEPER</td></tr> <tr><td>J</td><td>CAB - DASH (OUTSIDE)</td></tr> <tr><td>K</td><td>ENGINE / RADIATOR</td></tr> <tr><td>L</td><td>TRANSMISSION</td></tr> <tr><td>M</td><td>CHASSIS / FRONT END (CAB DASH PANEL FORWARD)</td></tr> <tr><td>N</td><td>CHASSIS / CENTER SECTION (CAB DASH PANEL TO CAB REAR XMBR)</td></tr> <tr><td>P</td><td>CHASSIS / WHEEL BASE SECTION</td></tr> <tr><td>R</td><td>CHASSIS / SUSPENSION / REAR AXLE / AXLES</td></tr> <tr><td>S</td><td>CHASSIS / AF SECTION / STOP / TAIL / TURN LIGHTS</td></tr> <tr><td>T</td><td>TRAVEL DOORS</td></tr> <tr><td>U</td><td>HOOD MTD HEADLIGHTS / MARKER LIGHTS</td></tr> <tr><td>V</td><td>SLEEPER ROOF / BACK PANEL WIRING</td></tr> <tr><td>W</td><td>WARDROBE CABINET WIRING</td></tr> </tbody> </table>				CIRCUIT NUMBER	COLOR	DESCRIPTION	81	LTGN	POWER DOOR LOCKS	82	GY	WINDSHIELD WIPER	83	LTGN	POWER WINDOWS	84	LTGN	CIGAR LIGHTER	85	GY	HORN	86	LTGN	RADIO - ENTERTAINMENT / CLOCK	87	GY	WINDSHIELD WASHER	88	LTGN	CLOCK / HOURMETER	89	VT	AIR BAG	90	GY	HYDRAULIC BRAKE PUMP	91	VT	INTERCOMMUNICATION	92	TN	TRANSMISSION CONTROLS - ELECTRONICS	93	TN	AXLE SHIFT CONTROL	94	GY	ANTILOCK BRAKE SYSTEM	95	TN	EXHAUST EMISSION	96	YL	SNOW PLOW LIGHTS / CRUISE CONTROLS	97	VT	ENGINE CONTROLS - ELECTRONIC	98	BK	DATALINK AND DIAGNOSTICS	99	VT	ACCELERATOR POSITION SENSOR (APS)	100	GY	AIR HORN (ELECTRIC SOLENOID ACTUATED)	101	TN	BRAKE APPLICATION AIR	102	YL	FLASH TO PASS	103	LTGN	BODY BUILDER AUXILIARY FEED	104	DKBL	REMOTE START / STOP	105	LTGN	HEATED SEATS	106	OR	HIGH VOLTAGE ALTERNATOR AC CHARGE	107	GY	INTRUMENT CLUSTER ELECTRONIC FEED (5V)	108	GY	BRAKE PAD WEAR SENSOR	109	GY	BRAKE STROKE / SLACK ADJUSTER	110	GY	INTRUMENT CLUSTER ELECTRONIC GROUND	111	TN	FUEL FILTER RESTRICTION TRANSDUCER	112	GY	LIFT GATE	PREFIX	LOCATION	A	CAB - INSTRUMENT PANEL MODULE	B	CAB - DRIVER CONTROL MODULE	C	CAB - HEADER / CLEARANCE LIGHTS	D	CAB - ROOF / REAR PANEL	E	CAB - LEFT DOOR / DOORS	F	CAB - RIGHT DOOR / DOORS	H	CAB - SLEEPER	J	CAB - DASH (OUTSIDE)	K	ENGINE / RADIATOR	L	TRANSMISSION	M	CHASSIS / FRONT END (CAB DASH PANEL FORWARD)	N	CHASSIS / CENTER SECTION (CAB DASH PANEL TO CAB REAR XMBR)	P	CHASSIS / WHEEL BASE SECTION	R	CHASSIS / SUSPENSION / REAR AXLE / AXLES	S	CHASSIS / AF SECTION / STOP / TAIL / TURN LIGHTS	T	TRAVEL DOORS	U	HOOD MTD HEADLIGHTS / MARKER LIGHTS	V	SLEEPER ROOF / BACK PANEL WIRING	W	WARDROBE CABINET WIRING
CIRCUIT NUMBER	COLOR	DESCRIPTION																																																																																																																																												
81	LTGN	POWER DOOR LOCKS																																																																																																																																												
82	GY	WINDSHIELD WIPER																																																																																																																																												
83	LTGN	POWER WINDOWS																																																																																																																																												
84	LTGN	CIGAR LIGHTER																																																																																																																																												
85	GY	HORN																																																																																																																																												
86	LTGN	RADIO - ENTERTAINMENT / CLOCK																																																																																																																																												
87	GY	WINDSHIELD WASHER																																																																																																																																												
88	LTGN	CLOCK / HOURMETER																																																																																																																																												
89	VT	AIR BAG																																																																																																																																												
90	GY	HYDRAULIC BRAKE PUMP																																																																																																																																												
91	VT	INTERCOMMUNICATION																																																																																																																																												
92	TN	TRANSMISSION CONTROLS - ELECTRONICS																																																																																																																																												
93	TN	AXLE SHIFT CONTROL																																																																																																																																												
94	GY	ANTILOCK BRAKE SYSTEM																																																																																																																																												
95	TN	EXHAUST EMISSION																																																																																																																																												
96	YL	SNOW PLOW LIGHTS / CRUISE CONTROLS																																																																																																																																												
97	VT	ENGINE CONTROLS - ELECTRONIC																																																																																																																																												
98	BK	DATALINK AND DIAGNOSTICS																																																																																																																																												
99	VT	ACCELERATOR POSITION SENSOR (APS)																																																																																																																																												
100	GY	AIR HORN (ELECTRIC SOLENOID ACTUATED)																																																																																																																																												
101	TN	BRAKE APPLICATION AIR																																																																																																																																												
102	YL	FLASH TO PASS																																																																																																																																												
103	LTGN	BODY BUILDER AUXILIARY FEED																																																																																																																																												
104	DKBL	REMOTE START / STOP																																																																																																																																												
105	LTGN	HEATED SEATS																																																																																																																																												
106	OR	HIGH VOLTAGE ALTERNATOR AC CHARGE																																																																																																																																												
107	GY	INTRUMENT CLUSTER ELECTRONIC FEED (5V)																																																																																																																																												
108	GY	BRAKE PAD WEAR SENSOR																																																																																																																																												
109	GY	BRAKE STROKE / SLACK ADJUSTER																																																																																																																																												
110	GY	INTRUMENT CLUSTER ELECTRONIC GROUND																																																																																																																																												
111	TN	FUEL FILTER RESTRICTION TRANSDUCER																																																																																																																																												
112	GY	LIFT GATE																																																																																																																																												
PREFIX	LOCATION																																																																																																																																													
A	CAB - INSTRUMENT PANEL MODULE																																																																																																																																													
B	CAB - DRIVER CONTROL MODULE																																																																																																																																													
C	CAB - HEADER / CLEARANCE LIGHTS																																																																																																																																													
D	CAB - ROOF / REAR PANEL																																																																																																																																													
E	CAB - LEFT DOOR / DOORS																																																																																																																																													
F	CAB - RIGHT DOOR / DOORS																																																																																																																																													
H	CAB - SLEEPER																																																																																																																																													
J	CAB - DASH (OUTSIDE)																																																																																																																																													
K	ENGINE / RADIATOR																																																																																																																																													
L	TRANSMISSION																																																																																																																																													
M	CHASSIS / FRONT END (CAB DASH PANEL FORWARD)																																																																																																																																													
N	CHASSIS / CENTER SECTION (CAB DASH PANEL TO CAB REAR XMBR)																																																																																																																																													
P	CHASSIS / WHEEL BASE SECTION																																																																																																																																													
R	CHASSIS / SUSPENSION / REAR AXLE / AXLES																																																																																																																																													
S	CHASSIS / AF SECTION / STOP / TAIL / TURN LIGHTS																																																																																																																																													
T	TRAVEL DOORS																																																																																																																																													
U	HOOD MTD HEADLIGHTS / MARKER LIGHTS																																																																																																																																													
V	SLEEPER ROOF / BACK PANEL WIRING																																																																																																																																													
W	WARDROBE CABINET WIRING																																																																																																																																													
CHK	DATE	CHANGE	REV	REFERENCE	DRAWN	NAME																																																																																																																																								
CNA1	14JAN09	TITLE WAS CIRCUIT	B	61254R	U00K640	CIRCUIT DIAGRAM, PROSTAR, LONESTAR																																																																																																																																								
		DIAGRAM, PROSTAR			59637L	DATE	PART NO.																																																																																																																																							
						31AUG06	AE08055894																																																																																																																																							
							SHEET 006																																																																																																																																							

Figure 6 Circuit Number Identification and Color (Cont.)

2.7. LAMP BULB CHART, P. 7

INTERNATIONAL TRUCK AND ENGINE CORPORATION				ELECTRICAL CIRCUIT DIAGRAM		CHAPTER 2																																																																			
THIS PRINT IS PROVIDED ON A RESTRICTED BASIS AND IS NOT TO BE USED IN ANY WAY DETRIMENTAL TO THE INTEREST OF INTERNATIONAL TRUCK AND ENGINE CORPORATION.				LAMP BULB CHART																																																																					
<table border="1"> <thead> <tr> <th>BULB APPLICATION</th> <th>CANDLE POWER OR WATT</th> <th>BULB TRADE NUMBER</th> </tr> </thead> <tbody> <tr><td>BACK-UP LIGHT (SUPER 40)</td><td>32 CP</td><td>TL40204</td></tr> <tr><td>CLEARANCE &amp; IDENTIFICATION</td><td>3 CP</td><td>N/A</td></tr> <tr><td>COURTESY LIGHT</td><td>2 CP</td><td>193</td></tr> <tr><td>CAB DOME LIGHT</td><td>12 WATT</td><td>211-2</td></tr> <tr><td>SLEEPER DOME LIGHT (FLUORESCENT)</td><td>15 WATT</td><td>F15T8CW</td></tr> <tr><td>FOG LIGHT</td><td>100 WATT</td><td>4921-1</td></tr> <tr><td>MAP LIGHT</td><td>3 CP</td><td>211-2</td></tr> <tr><td>SIDE MARKER / TURN LIGHT</td><td>27 WATT</td><td>3156</td></tr> <tr><td>STOP, TURN AND TAIL LIGHT (SUPER 40)</td><td>32/2 CP</td><td>TL40248R</td></tr> <tr><td>HEADLIGHTS, HIGH BEAM</td><td>65 WATT</td><td>9005</td></tr> <tr><td>HEADLIGHTS, LOW BEAM</td><td>55 WATT</td><td>9006</td></tr> <tr><td>FRONT MARKER / TURN LIGHT</td><td>27 / 8 WATT</td><td>3357AK</td></tr> <tr><td>SIDE MARKER (FRONT)</td><td>4 WATT</td><td>194</td></tr> <tr><td>LICENSE PLATE LIGHT (SUPER 40)</td><td>2 CP</td><td>TL1508</td></tr> <tr><td>BOC WORK LIGHT (DAY CAB)</td><td>35 WATT</td><td>4411</td></tr> <tr><td>WORK LIGHTS (IN SLEEPER BACK PANEL)</td><td>15 CP</td><td>1003</td></tr> <tr><td>LUGGAGE COMPARTMENT LIGHT</td><td>12 WATT</td><td>211-2</td></tr> <tr><td>READING LIGHT</td><td>15 CP</td><td>912</td></tr> <tr><td>ACCENT LIGHT</td><td>12 WATT</td><td>211-2</td></tr> <tr><td>SLEEPER FLOOR LIGHT</td><td>2 CP</td><td>193</td></tr> <tr><td>CABINET / WARDROBE LIGHT</td><td>5 WATT</td><td>7575</td></tr> </tbody> </table>				BULB APPLICATION	CANDLE POWER OR WATT	BULB TRADE NUMBER	BACK-UP LIGHT (SUPER 40)	32 CP	TL40204	CLEARANCE & IDENTIFICATION	3 CP	N/A	COURTESY LIGHT	2 CP	193	CAB DOME LIGHT	12 WATT	211-2	SLEEPER DOME LIGHT (FLUORESCENT)	15 WATT	F15T8CW	FOG LIGHT	100 WATT	4921-1	MAP LIGHT	3 CP	211-2	SIDE MARKER / TURN LIGHT	27 WATT	3156	STOP, TURN AND TAIL LIGHT (SUPER 40)	32/2 CP	TL40248R	HEADLIGHTS, HIGH BEAM	65 WATT	9005	HEADLIGHTS, LOW BEAM	55 WATT	9006	FRONT MARKER / TURN LIGHT	27 / 8 WATT	3357AK	SIDE MARKER (FRONT)	4 WATT	194	LICENSE PLATE LIGHT (SUPER 40)	2 CP	TL1508	BOC WORK LIGHT (DAY CAB)	35 WATT	4411	WORK LIGHTS (IN SLEEPER BACK PANEL)	15 CP	1003	LUGGAGE COMPARTMENT LIGHT	12 WATT	211-2	READING LIGHT	15 CP	912	ACCENT LIGHT	12 WATT	211-2	SLEEPER FLOOR LIGHT	2 CP	193	CABINET / WARDROBE LIGHT	5 WATT	7575				
BULB APPLICATION	CANDLE POWER OR WATT	BULB TRADE NUMBER																																																																							
BACK-UP LIGHT (SUPER 40)	32 CP	TL40204																																																																							
CLEARANCE & IDENTIFICATION	3 CP	N/A																																																																							
COURTESY LIGHT	2 CP	193																																																																							
CAB DOME LIGHT	12 WATT	211-2																																																																							
SLEEPER DOME LIGHT (FLUORESCENT)	15 WATT	F15T8CW																																																																							
FOG LIGHT	100 WATT	4921-1																																																																							
MAP LIGHT	3 CP	211-2																																																																							
SIDE MARKER / TURN LIGHT	27 WATT	3156																																																																							
STOP, TURN AND TAIL LIGHT (SUPER 40)	32/2 CP	TL40248R																																																																							
HEADLIGHTS, HIGH BEAM	65 WATT	9005																																																																							
HEADLIGHTS, LOW BEAM	55 WATT	9006																																																																							
FRONT MARKER / TURN LIGHT	27 / 8 WATT	3357AK																																																																							
SIDE MARKER (FRONT)	4 WATT	194																																																																							
LICENSE PLATE LIGHT (SUPER 40)	2 CP	TL1508																																																																							
BOC WORK LIGHT (DAY CAB)	35 WATT	4411																																																																							
WORK LIGHTS (IN SLEEPER BACK PANEL)	15 CP	1003																																																																							
LUGGAGE COMPARTMENT LIGHT	12 WATT	211-2																																																																							
READING LIGHT	15 CP	912																																																																							
ACCENT LIGHT	12 WATT	211-2																																																																							
SLEEPER FLOOR LIGHT	2 CP	193																																																																							
CABINET / WARDROBE LIGHT	5 WATT	7575																																																																							
CHK	DATE	CHANGE	REV	REFERENCE	DRAWN	NAME																																																																			
CNA1	14JAN09	TITLE WAS CIRCUIT	B	61254R	U00K640	CIRCUIT DIAGRAM, PROSTAR, LONESTAR																																																																			
	DIAGRAM, PROSTAR				RELEASE NO. 59637L	DATE 31AUG06	PART NO. AE08055894																																																																		
						SHEET	007																																																																		

Figure 7 Lamp Bulb Chart

2.8. RELAY FUNCTION AND WIRING GUIDE, P. 8

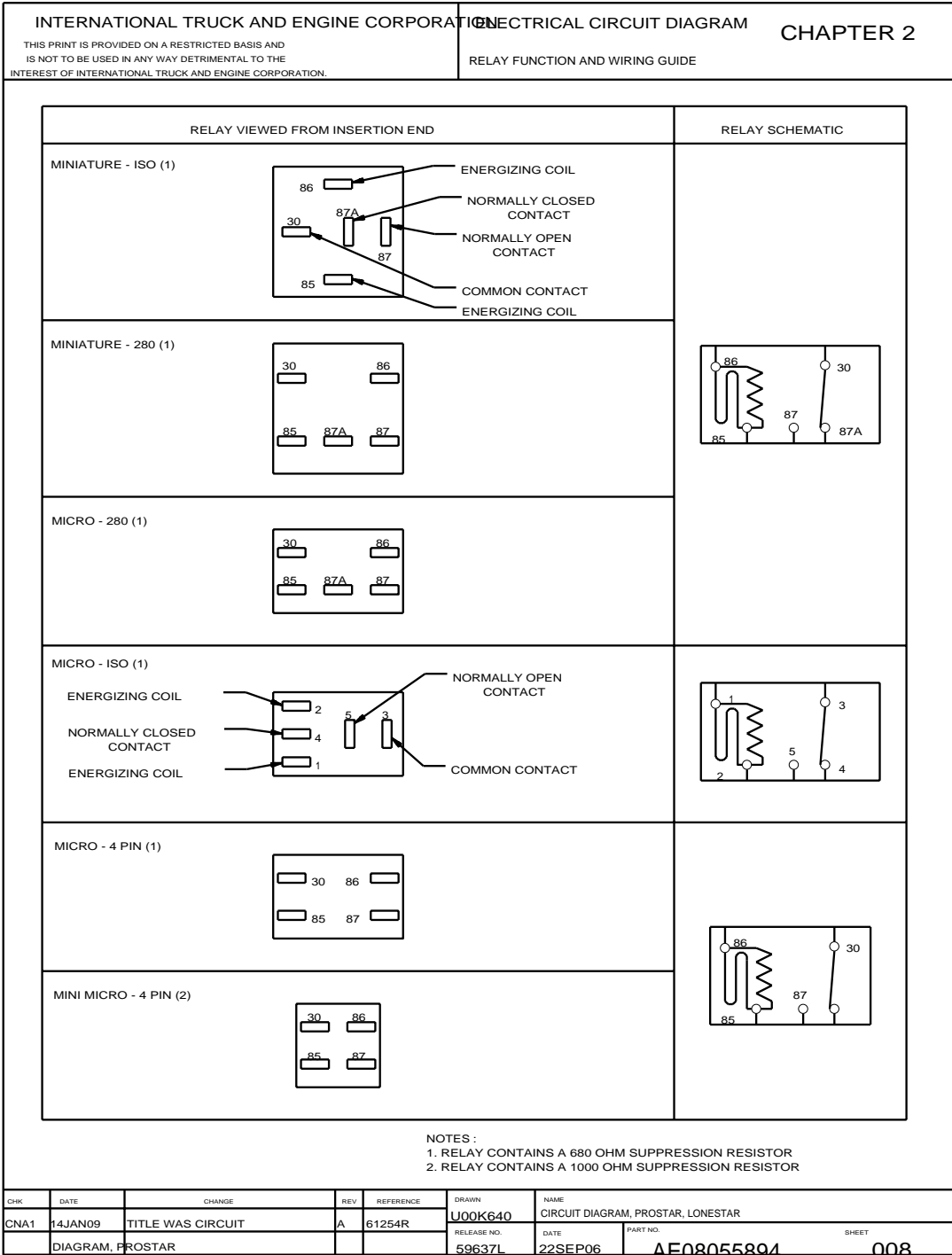


Figure 8 Relay Function and Wiring Guide

2.9. SCHEMATIC SYMBOL CHART, P. 9

INTERNATIONAL TRUCK AND ENGINE CORPORATION				ELECTRICAL CIRCUIT DIAGRAM CHAPTER 2			
THIS PRINT IS PROVIDED ON A RESTRICTED BASIS AND IS NOT TO BE USED IN ANY WAY DETRIMENTAL TO THE INTEREST OF INTERNATIONAL TRUCK AND ENGINE CORPORATION.				SCHEMATIC SYMBOL CHART			
SYMBOL		DESCRIPTION		SYMBOL		DESCRIPTION	
		AIR DRYER				CIGAR LIGHTER	
		ALARM		TYPE 1      TYPE 2 OR 3 		CIRCUIT BREAKER	
		ALTERNATOR				DIODE	
		AMMETER				DIODE, LIGHT EMITTING	
		BATTERY				FAN SOLENOID	
		BLUNT CUT CIRCUIT				FEMALE TERMINAL	
		BUSBAR				FUSE	
CHK	DATE	CHANGE	REV	REFERENCE	DRAWN	NAME	
CNA1	14JAN09	TITLE WAS CIRCUIT	A	61254R	U00K640	CIRCUIT DIAGRAM, PROSTAR, LONESTAR	
		DIAGRAM, PROSTAR			RELEASE NO. 59637L	DATE 31AUG06	PART NO. AE08055894
							SHEET 009

Figure 9 Schematic Symbol Chart

2.10. SCHEMATIC SYMBOL CHART (CONT.), P. 10

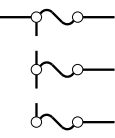

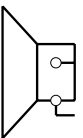

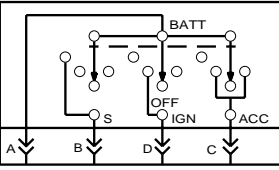

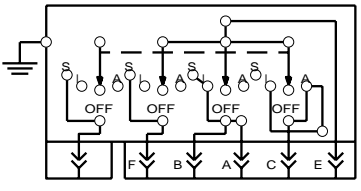

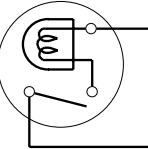

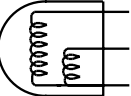

INTERNATIONAL TRUCK AND ENGINE CORPORATION				ELECTRICAL CIRCUIT DIAGRAM				CHAPTER 2			
THIS PRINT IS PROVIDED ON A RESTRICTED BASIS AND IS NOT TO BE USED IN ANY WAY DETRIMENTAL TO THE INTEREST OF INTERNATIONAL TRUCK AND ENGINE CORPORATION.				SCHEMATIC SYMBOL CHART (CONT)							
SYMBOL	DESCRIPTION	SYMBOL	DESCRIPTION								
	FUSES W/ BUSBAR		FUSIBLE LINK		HORN						
	GROUND W/ STUD		KEY SWITCH								
	GROUND W/ STUD		KEY SWITCH, COMPLEX								
	HEATER		LIGHT W/ SWITCH								
	HOLDER, FUSE W/ BUSBAR		LIGHT, DOUBLE FILAMENT								
					LIGHT, SINGLE FILAMENT						
CHK	DATE	CHANGE	REV	REFERENCE	DRAWN	NAME					
CNA1	14JAN09	TITLE WAS CIRCUIT	B	61254R	U00K640	CIRCUIT DIAGRAM, PROSTAR, LONESTAR					
					RELEASE NO.	DATE	PART NO.	SHEET			
					59637L	31AUG06	AE08055894	010			

Figure 10 Schematic Symbol Chart (Cont.)

2.11. SCHEMATIC SYMBOL CHART (CONT.), P. 11

INTERNATIONAL TRUCK AND ENGINE CORPORATION				ELECTRICAL CIRCUIT DIAGRAM				CHAPTER 2			
THIS PRINT IS PROVIDED ON A RESTRICTED BASIS AND IS NOT TO BE USED IN ANY WAY DETRIMENTAL TO THE INTEREST OF INTERNATIONAL TRUCK AND ENGINE CORPORATION.				SCHEMATIC SYMBOL CHART (CONT)							
SYMBOL		DESCRIPTION		SYMBOL		DESCRIPTION		SYMBOL		DESCRIPTION	
		MALE TERMINAL				RESISTOR				SENDER - FUEL, OIL, TEMP, WATER	
		MOTOR				PASS THRU CONNECTION				SENSOR, PRESSURE. ABS 6	
		PRESSURE SWITCH				RELAY, FIVE TERMINAL				SENSOR, MAGNETIC	
		RELAY, FOUR TERMINAL				SENSOR, YAW				SOLENOID	
		RELAY, LATCHING				SOLENOID W/ DIODE					
CHK	DATE	CHANGE	REV	REFERENCE	DRAWN	NAME					
CNA1	14JAN09	TITLE WAS CIRCUIT	B	61254R	U00K640	CIRCUIT DIAGRAM, PROSTAR, LONESTAR					
		DIAGRAM, PROSTAR			59637L	DATE	PART NO.	SHEET			
						31AUG06	AE08055894	011			

Figure 11 Schematic Symbol Chart (Cont.)

2.12. SCHEMATIC SYMBOL CHART (CONT.), P. 12

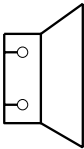


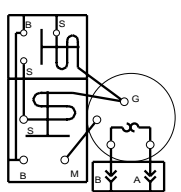


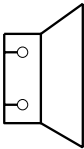


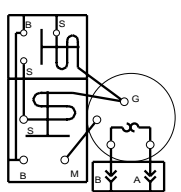



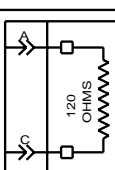
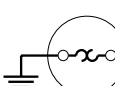
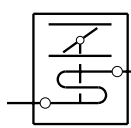
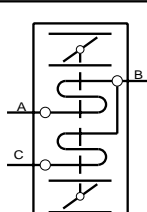


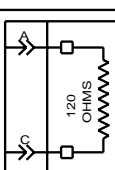
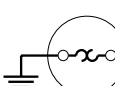
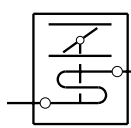
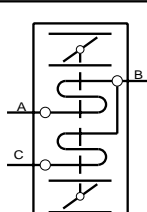

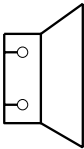


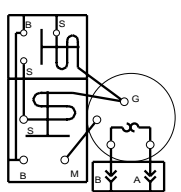



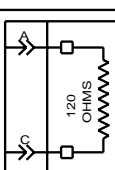
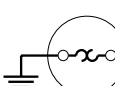
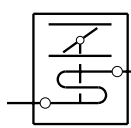
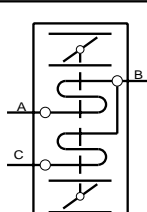

INTERNATIONAL TRUCK AND ENGINE CORPORATION				ELECTRICAL CIRCUIT DIAGRAM				CHAPTER 2																											
THIS PRINT IS PROVIDED ON A RESTRICTED BASIS AND IS NOT TO BE USED IN ANY WAY DETRIMENTAL TO THE INTEREST OF INTERNATIONAL TRUCK AND ENGINE CORPORATION.				SCHEMATIC SYMBOL CHART (CONT)																															
<table border="1"> <thead> <tr> <th>SYMBOL</th> <th>DESCRIPTION</th> </tr> </thead> <tbody> <tr> <td></td> <td>SPEAKER</td> </tr> <tr> <td></td> <td>SPLICE</td> </tr> <tr> <td></td> <td>STUD</td> </tr> <tr> <td></td> <td>START MOTOR W/ TOCP</td> </tr> <tr> <td></td> <td>SWITCH, MECHANICAL (NORMALLY OPEN)</td> </tr> <tr> <td></td> <td>SWITCH, MECHANICAL (NORMALLY CLOSED)</td> </tr> </tbody> </table>				SYMBOL	DESCRIPTION		SPEAKER		SPLICE		STUD		START MOTOR W/ TOCP		SWITCH, MECHANICAL (NORMALLY OPEN)		SWITCH, MECHANICAL (NORMALLY CLOSED)	<table border="1"> <thead> <tr> <th>SYMBOL</th> <th>DESCRIPTION</th> </tr> </thead> <tbody> <tr> <td></td> <td>SWITCH, PUSH BUTTON</td> </tr> <tr> <td></td> <td>TERMINATING RESISTOR</td> </tr> <tr> <td></td> <td>THERMOSTAT</td> </tr> <tr> <td></td> <td>VALVE, ETHER BOTTLE</td> </tr> <tr> <td></td> <td>VALVE, MODULATOR</td> </tr> <tr> <td></td> <td>THERMISTOR</td> </tr> </tbody> </table>				SYMBOL	DESCRIPTION		SWITCH, PUSH BUTTON		TERMINATING RESISTOR		THERMOSTAT		VALVE, ETHER BOTTLE		VALVE, MODULATOR		THERMISTOR
SYMBOL	DESCRIPTION																																		
	SPEAKER																																		
	SPLICE																																		
	STUD																																		
	START MOTOR W/ TOCP																																		
	SWITCH, MECHANICAL (NORMALLY OPEN)																																		
	SWITCH, MECHANICAL (NORMALLY CLOSED)																																		
SYMBOL	DESCRIPTION																																		
	SWITCH, PUSH BUTTON																																		
	TERMINATING RESISTOR																																		
	THERMOSTAT																																		
	VALVE, ETHER BOTTLE																																		
	VALVE, MODULATOR																																		
	THERMISTOR																																		
CHK	DATE	CHANGE	REV	REFERENCE	DRAWN	NAME	RELEASE NO.	DATE	PART NO.	SHEET																									
CNA1	14JAN09	TITLE WAS CIRCUIT	B	61254R	U00K640	CIRCUIT DIAGRAM, PROSTAR, LONESTAR	59637L	31AUG06	AE08055894	012																									
		DIAGRAM, PROSTAR																																	

Figure 12 Schematic Symbol Chart (Cont.)

### 3. 12 VOLT POWER DISTRIBUTION CIRCUIT DIAGRAMS (CHAPTER 3)

#### 3.1. BATTERY FEED, P. 1

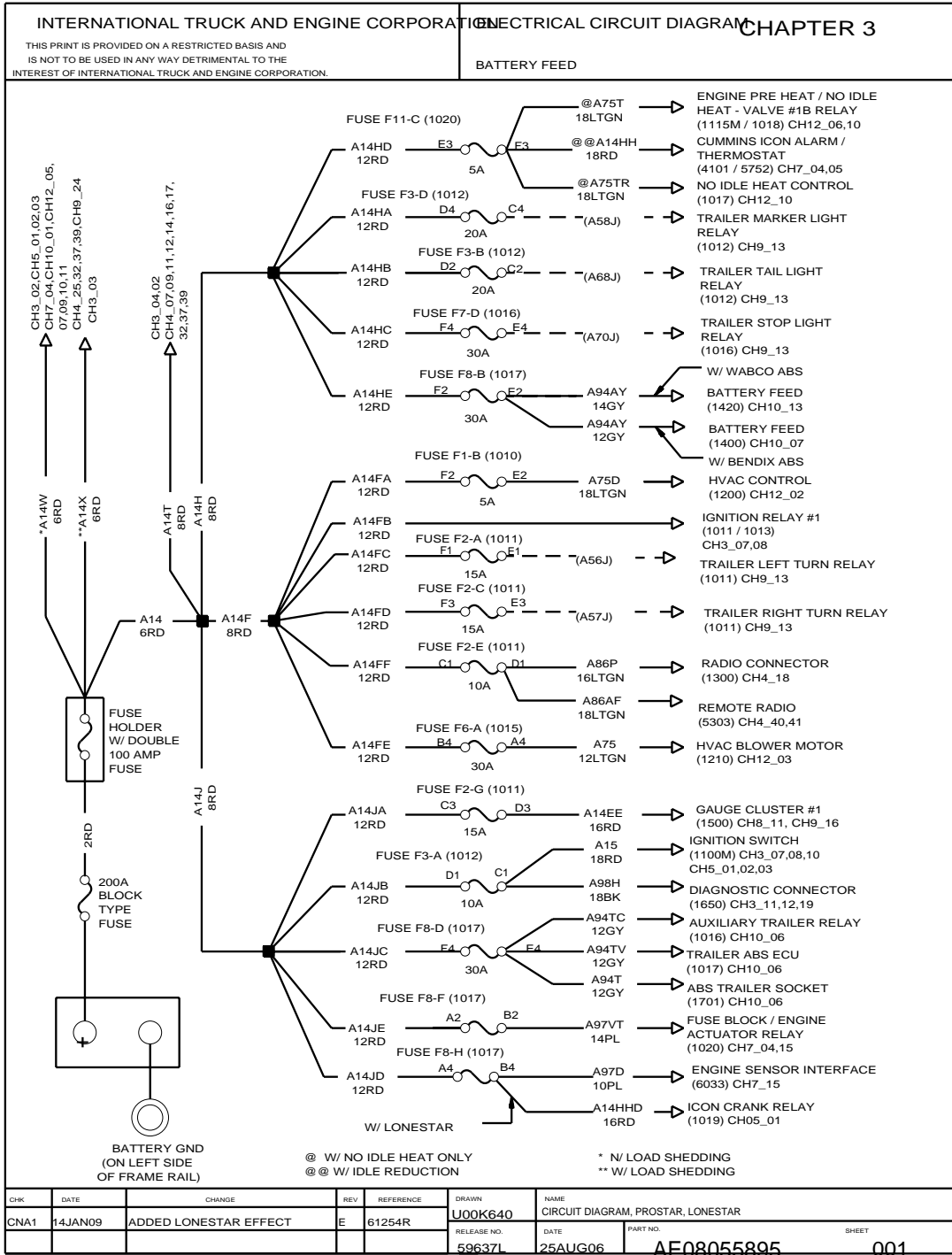


Figure 13 Battery Feed

3.2. BATTERY FEED (CONT.), P. 2

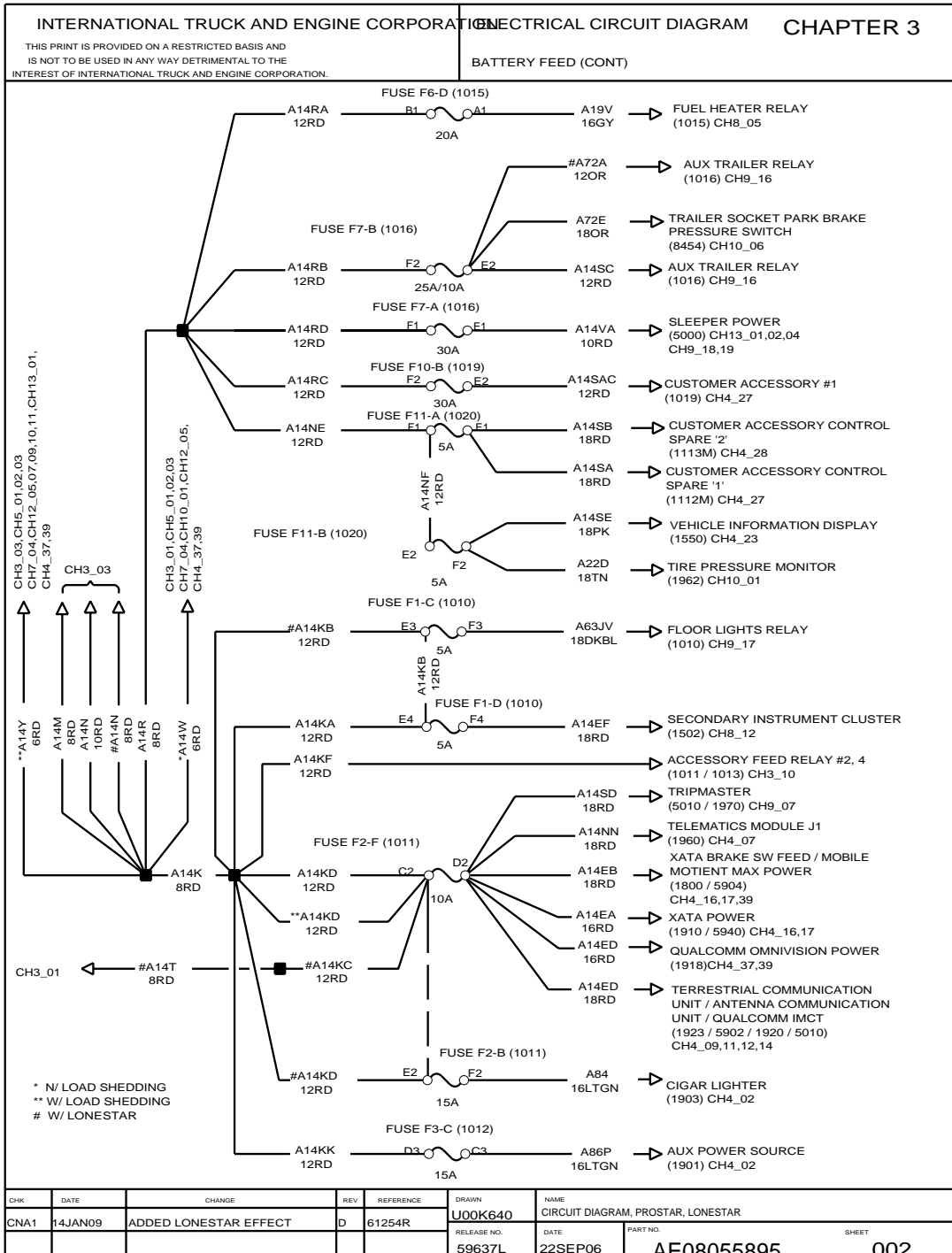


Figure 14 Battery Feed (Cont.)

3.3. BATTERY FEED (CONT.), P. 3

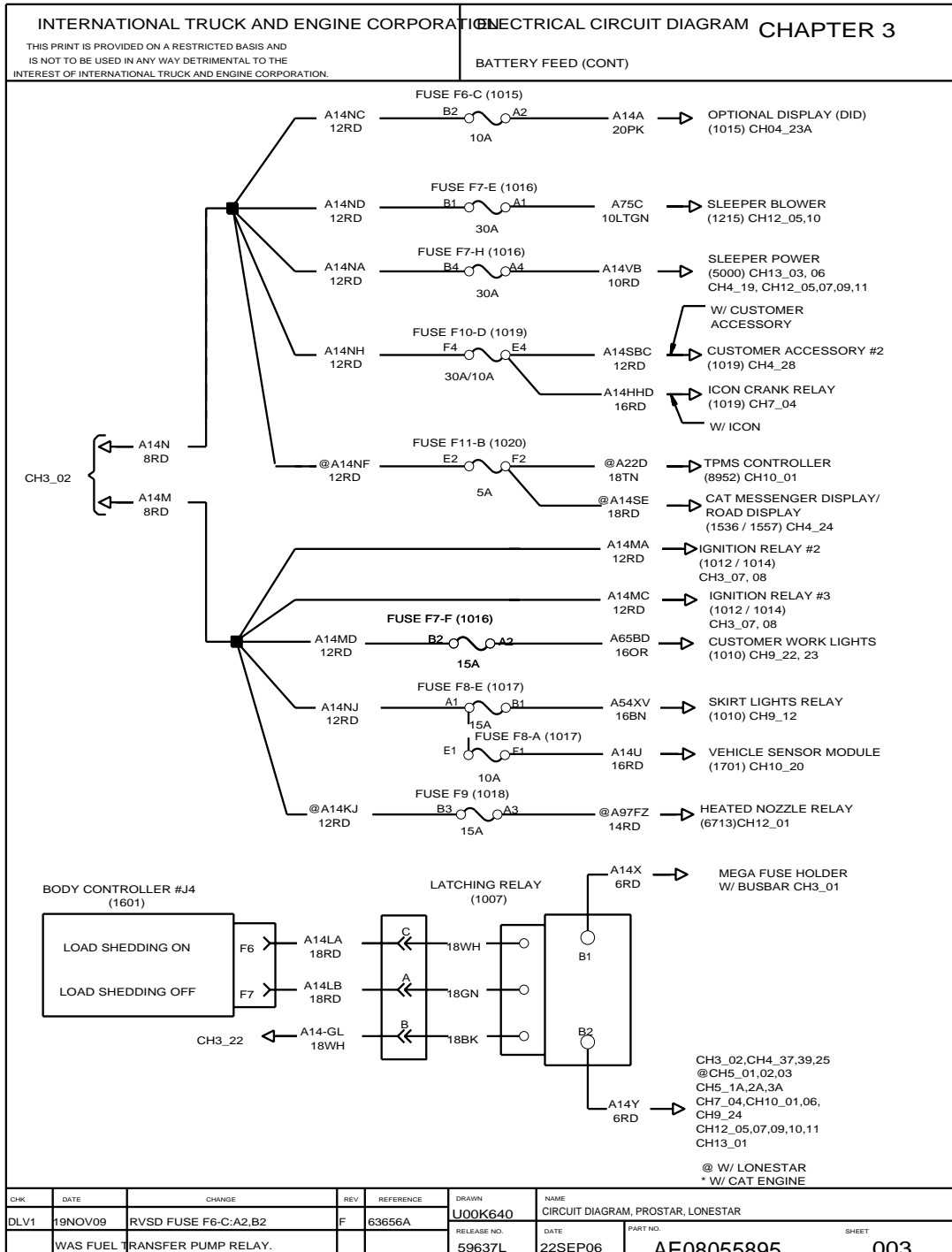


Figure 15 Battery Feed (Cont.)

3.4. BATTERY FEED (CONT.), P. 4

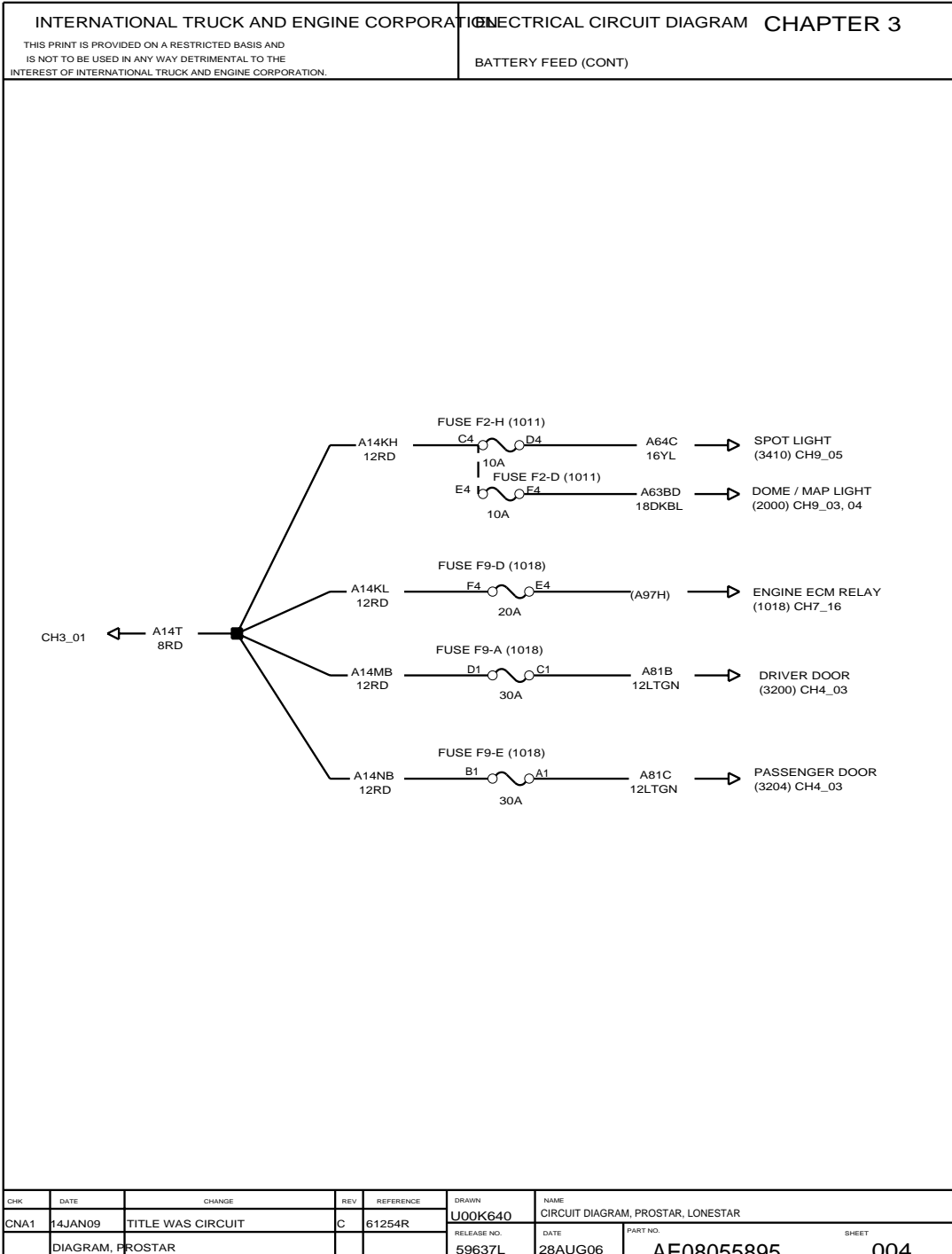


Figure 16 Battery Feed (Cont.)

3.5. BLANK PAGE, P. 5

INTERNATIONAL TRUCK AND ENGINE CORPORATION				ELECTRICAL CIRCUIT DIAGRAM CHAPTER 3			
THIS PRINT IS PROVIDED ON A RESTRICTED BASIS AND IS NOT TO BE USED IN ANY WAY DETRIMENTAL TO THE INTEREST OF INTERNATIONAL TRUCK AND ENGINE CORPORATION.							
<p style="font-size: 24px; margin: 0;">PAGE INTENTIONALLY</p> <p style="font-size: 24px; margin: 0;">KEPT BLANK</p>							
CHK	DATE	CHANGE	REV	REFERENCE	DRAWN	NAME	
CNA1	14JAN09	TITLE WAS CIRCUIT	A	61254R	U00K640	CIRCUIT DIAGRAM, PROSTAR, LONESTAR	
		DIAGRAM, PROSTAR			RELEASE NO. 59637L	DATE 28OCT05	PART NO. AE08055895
						SHEET	005

Figure 17 Blank Page

3.6. BLANK PAGE, P. 6

INTERNATIONAL TRUCK AND ENGINE CORPORATION				ELECTRICAL CIRCUIT DIAGRAM				CHAPTER 3	
THIS PRINT IS PROVIDED ON A RESTRICTED BASIS AND IS NOT TO BE USED IN ANY WAY DETRIMENTAL TO THE INTEREST OF INTERNATIONAL TRUCK AND ENGINE CORPORATION.									
<p>PAGE INTENTIONALLY KEPT BLANK</p>									
CHK	DATE	CHANGE	REV	REFERENCE	DRAWN	NAME			
CNA1	14JAN09	TITLE WAS CIRCUIT	A	61254R	U00K640	CIRCUIT DIAGRAM, PROSTAR, LONESTAR			
					RELEASE NO.	DATE	PART NO.	SHEET	
					59637L	28OCT05	AE08055895	006	

Figure 18 Blank Page

3.7. IGNITION FEED — STANDARD AND REMOTE START/STOP, P. 7

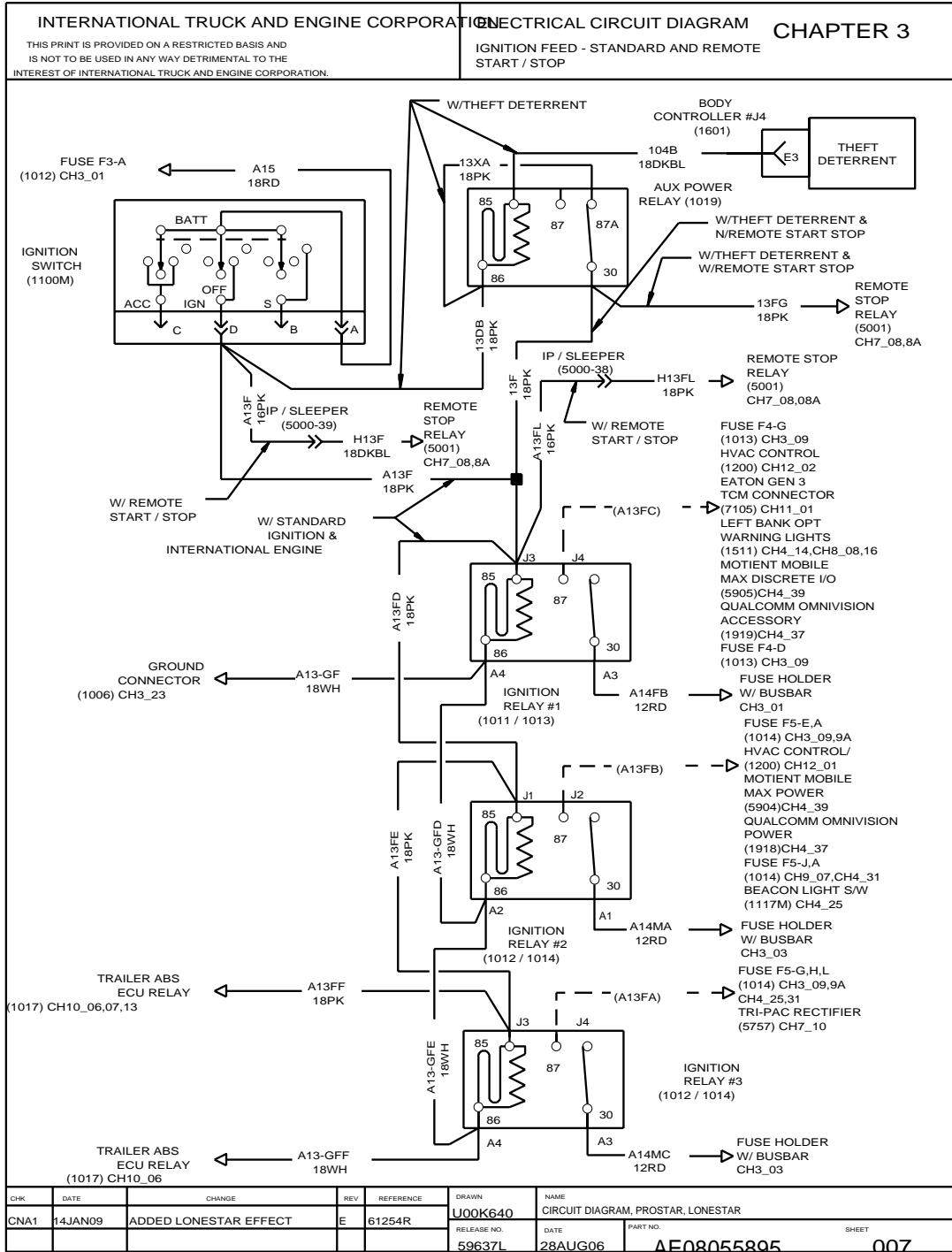


Figure 19 Ignition Feed — Standard and Remote Start/Stop

3.8. IGNITION FEED — ICON, P. 8

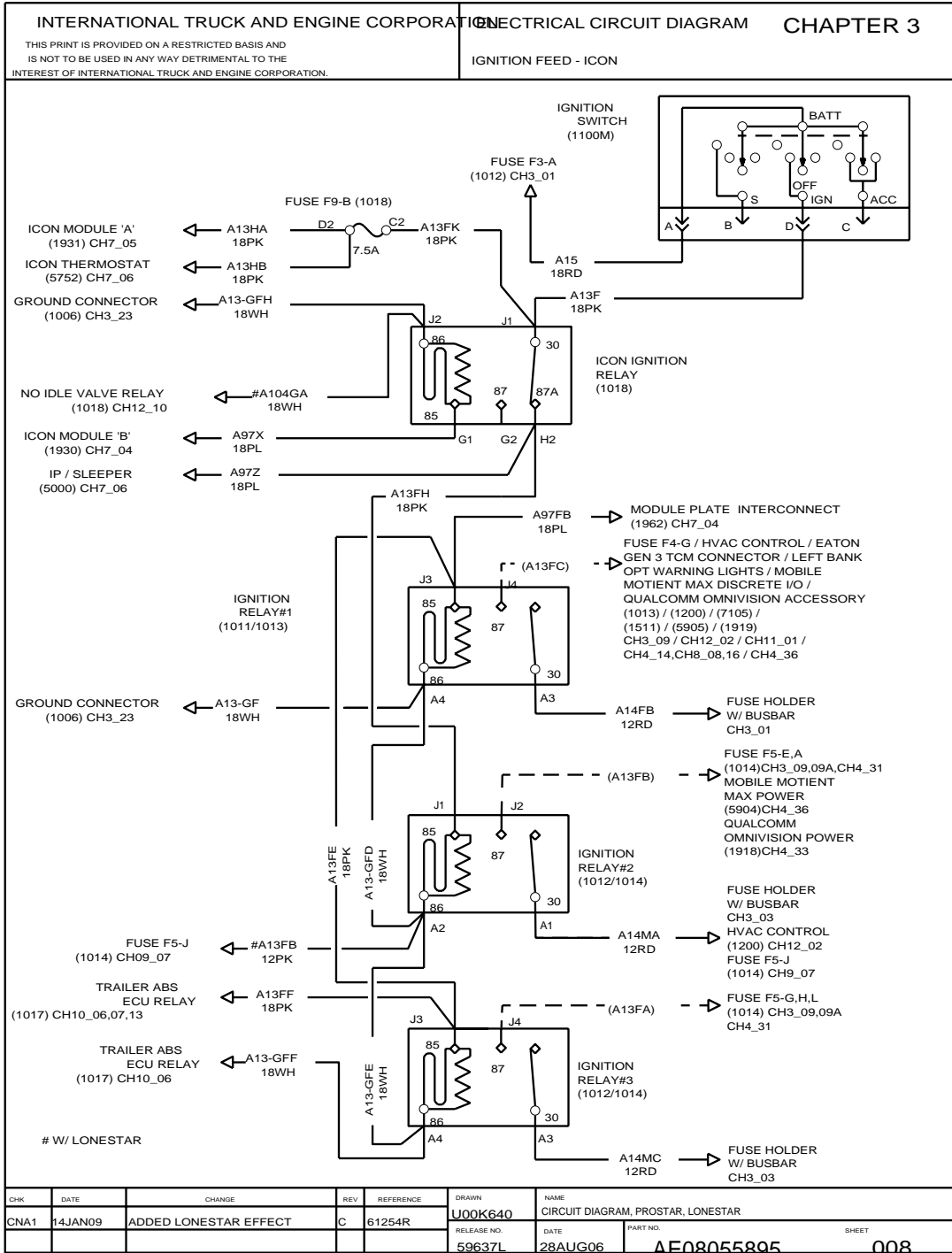


Figure 20 Ignition Feed — ICON

3.9. IGNITION FEED — STANDARD, P. 9

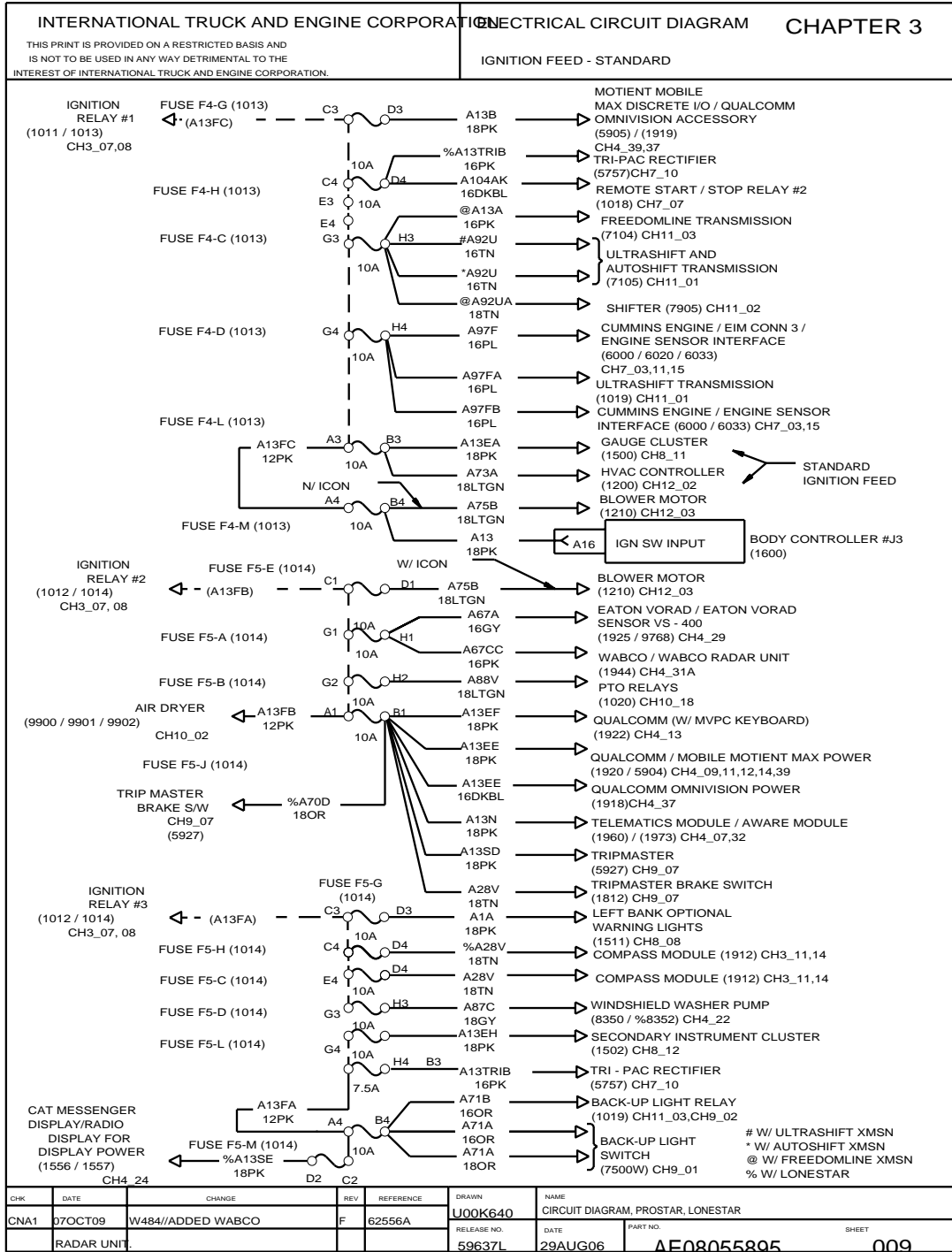


Figure 21 Ignition Feed — Standard

3.10. IGNITION FEED — STANDARD (LONESTAR), P. 9A

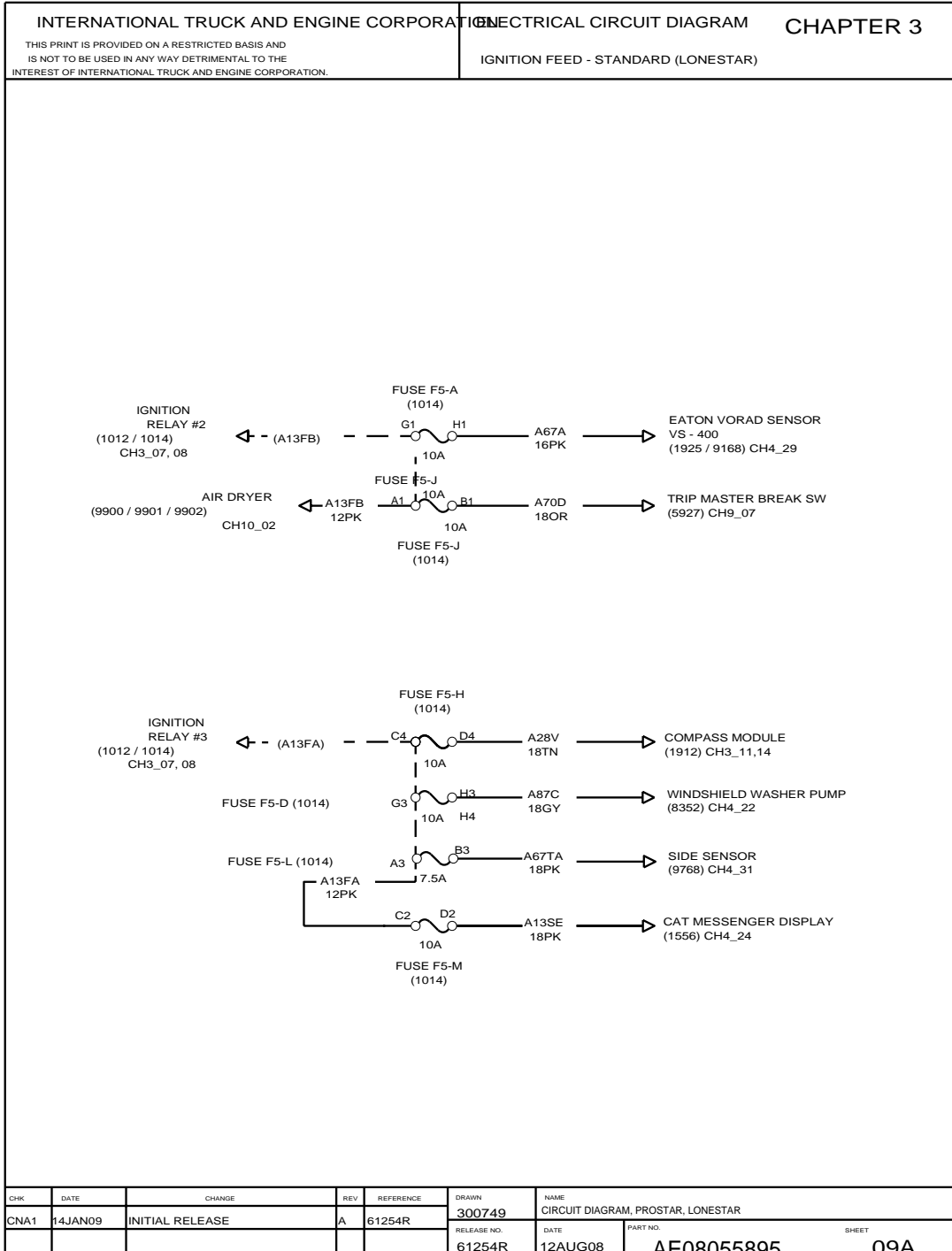


Figure 22 Ignition Feed — Standard (LoneStar)

3.11. ACCESSORY FEED, P. 10

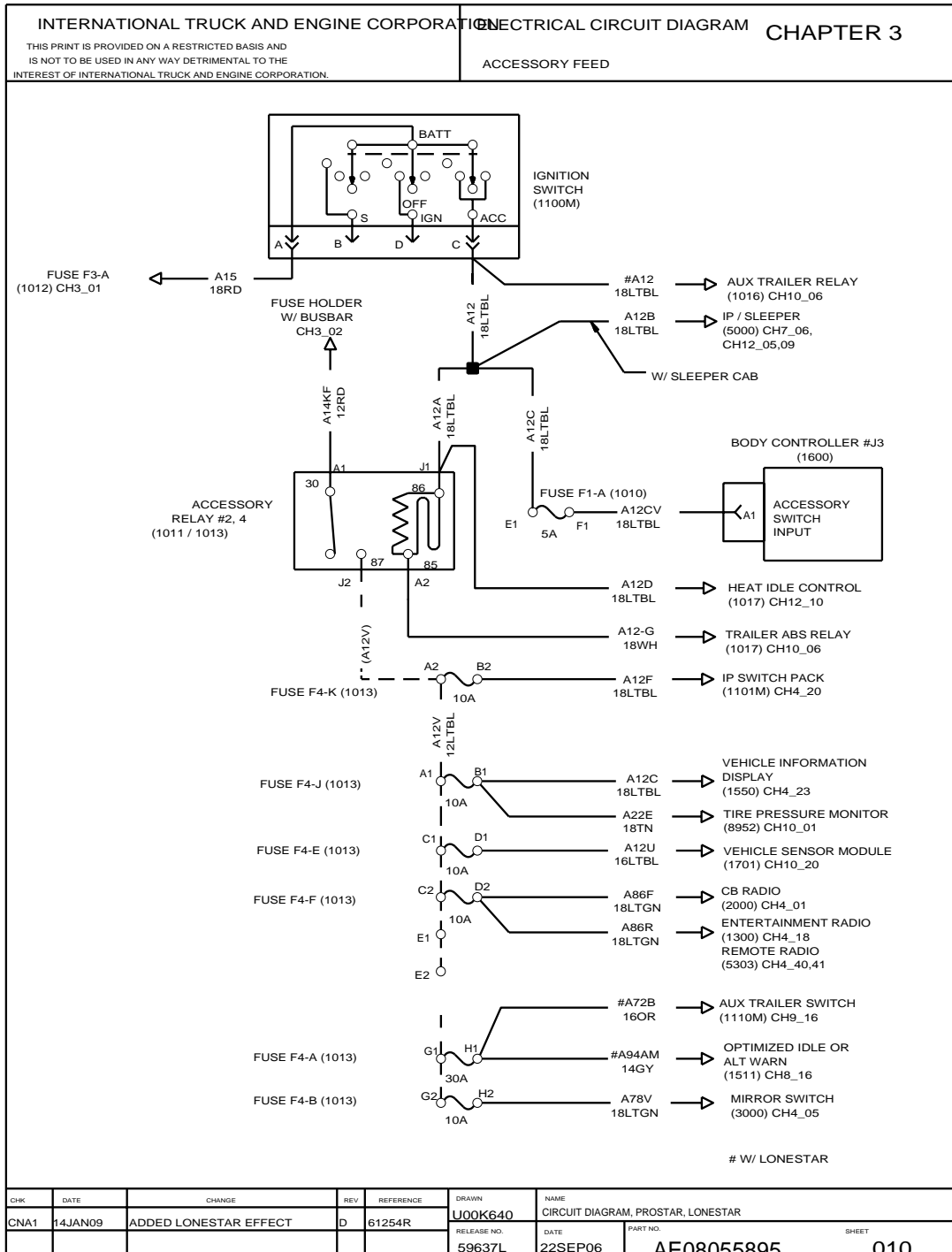


Figure 23 Accessory Feed

3.12. CAB J1939 COMPASS AND ABS EFFECTS, P. 11

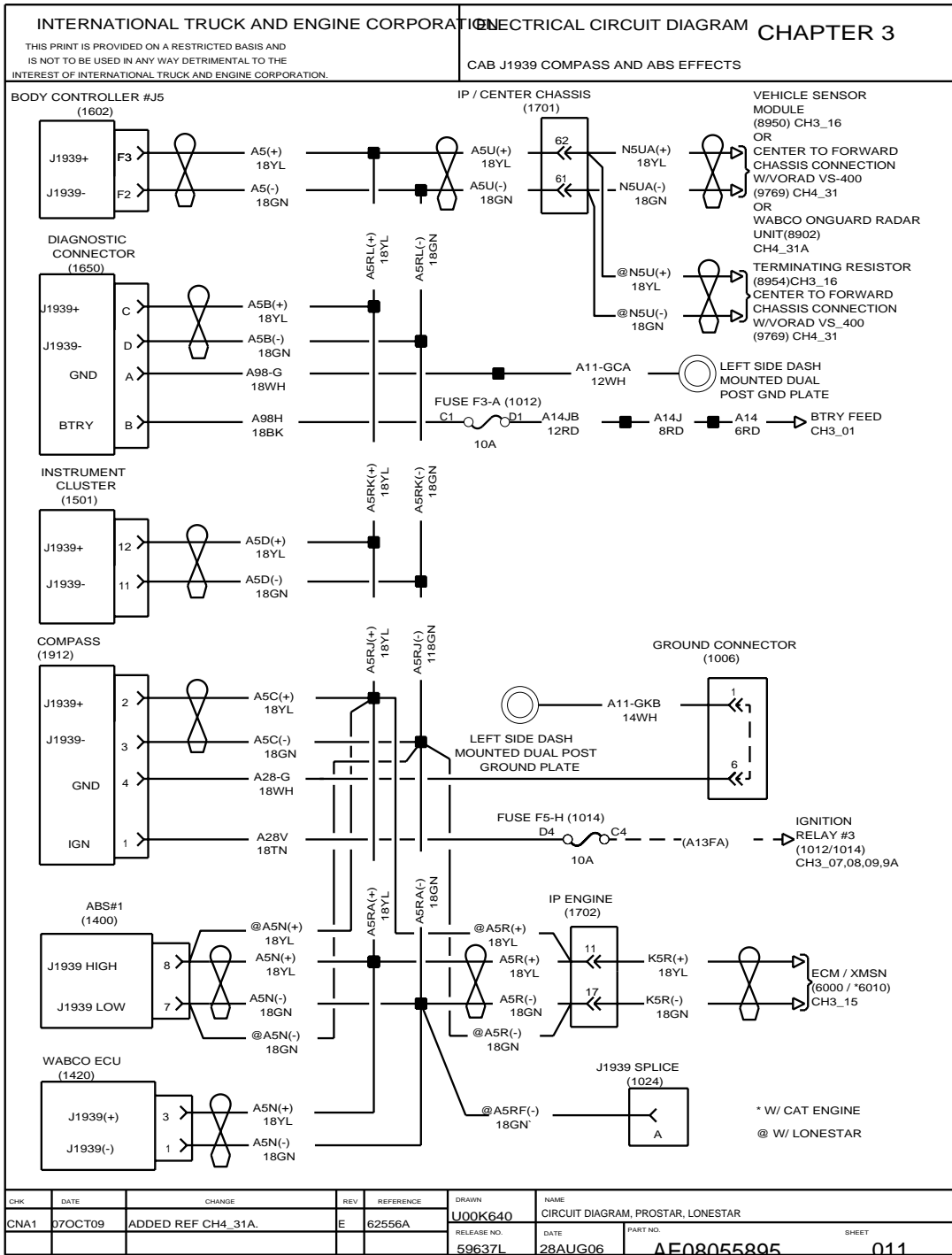


Figure 24 Cab J1939 COMPASS and ABS Effects

3.13. CAB J1939 WITH ALL OPTIONS, P. 12

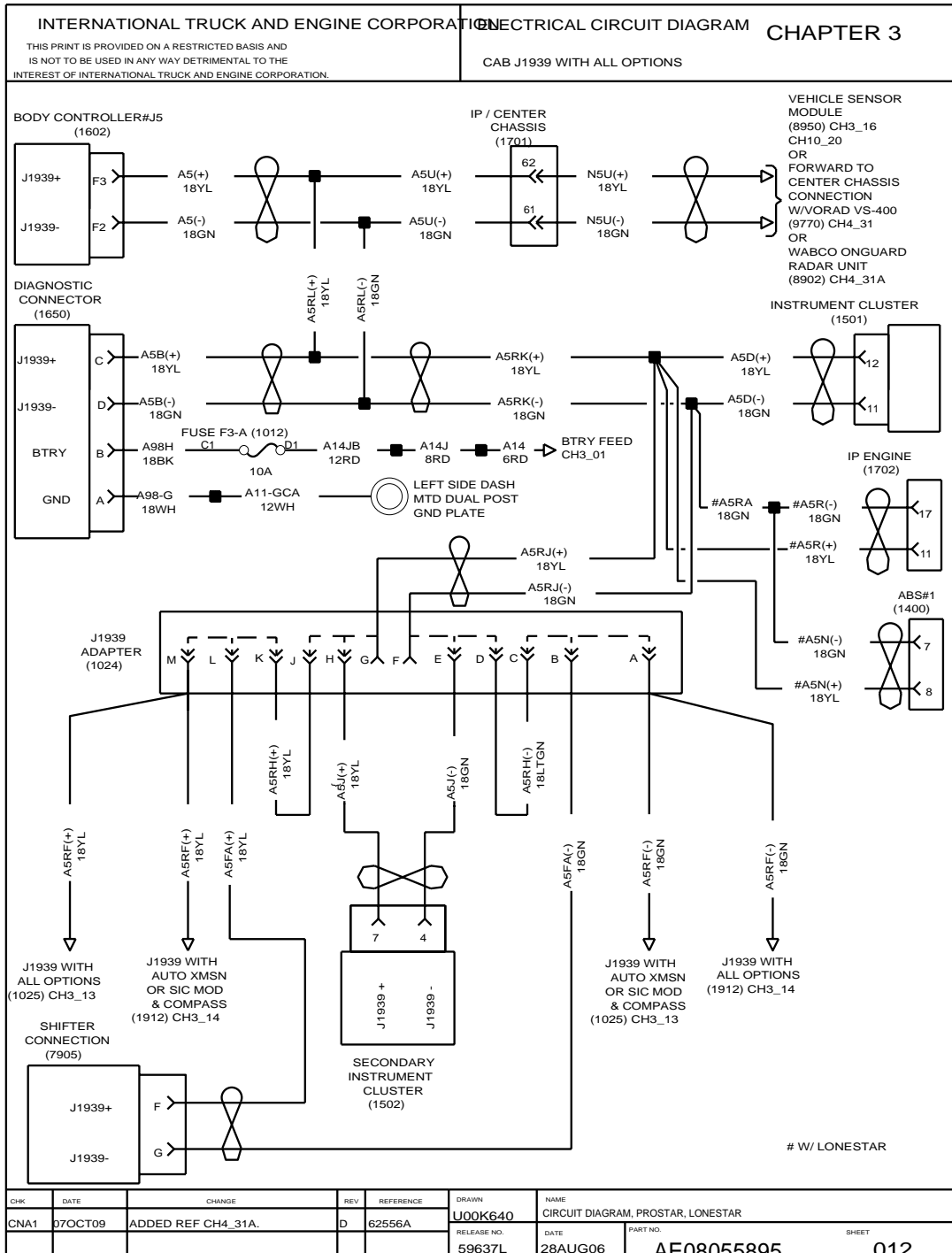


Figure 25 Cab J1939 with All Options

3.14. CAB J1939 WITH ALL OPTIONS, P. 13

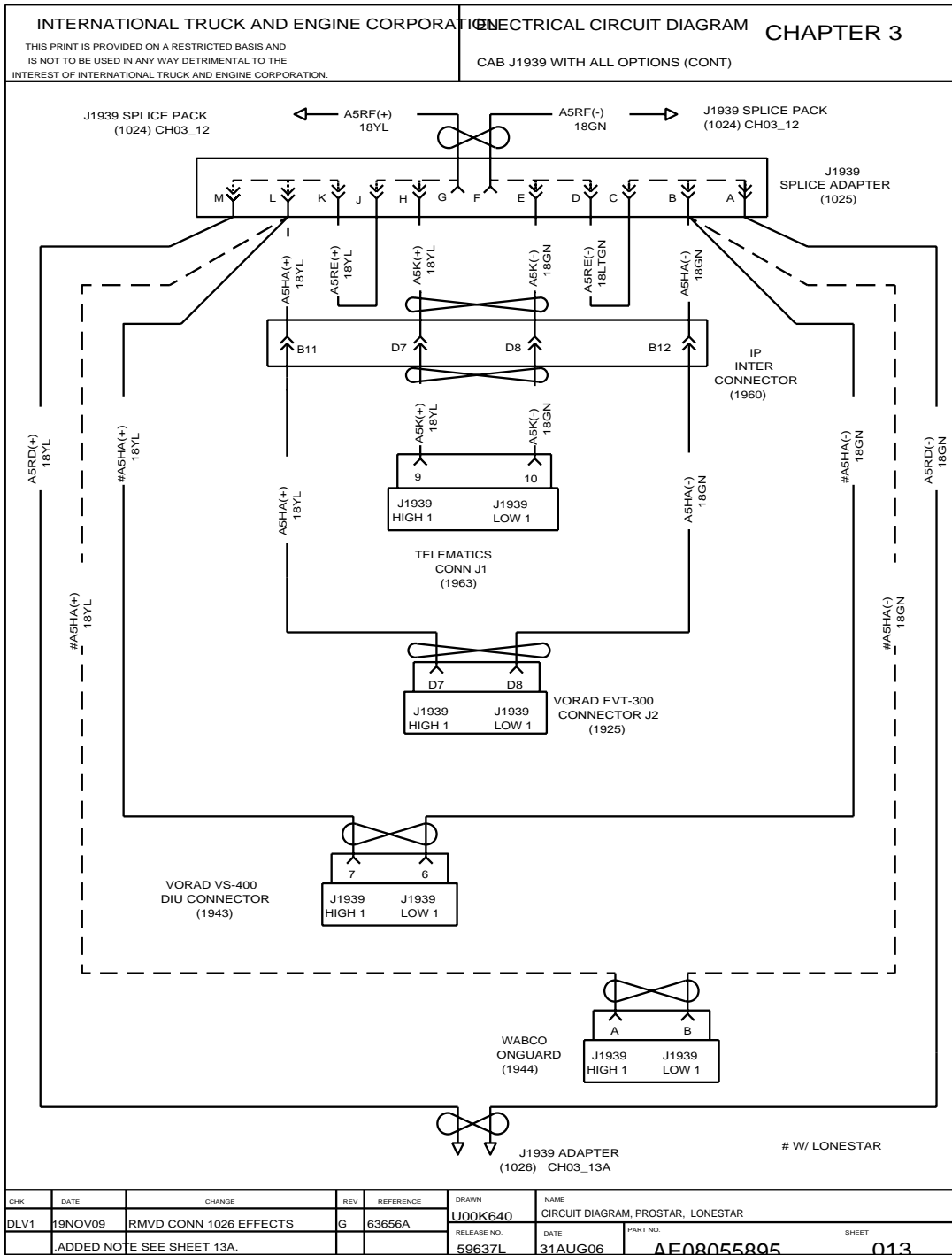


Figure 26 Cab J1939 with All Options

3.15. CAB J1939 WITH ALL OPTIONS, P. 13A

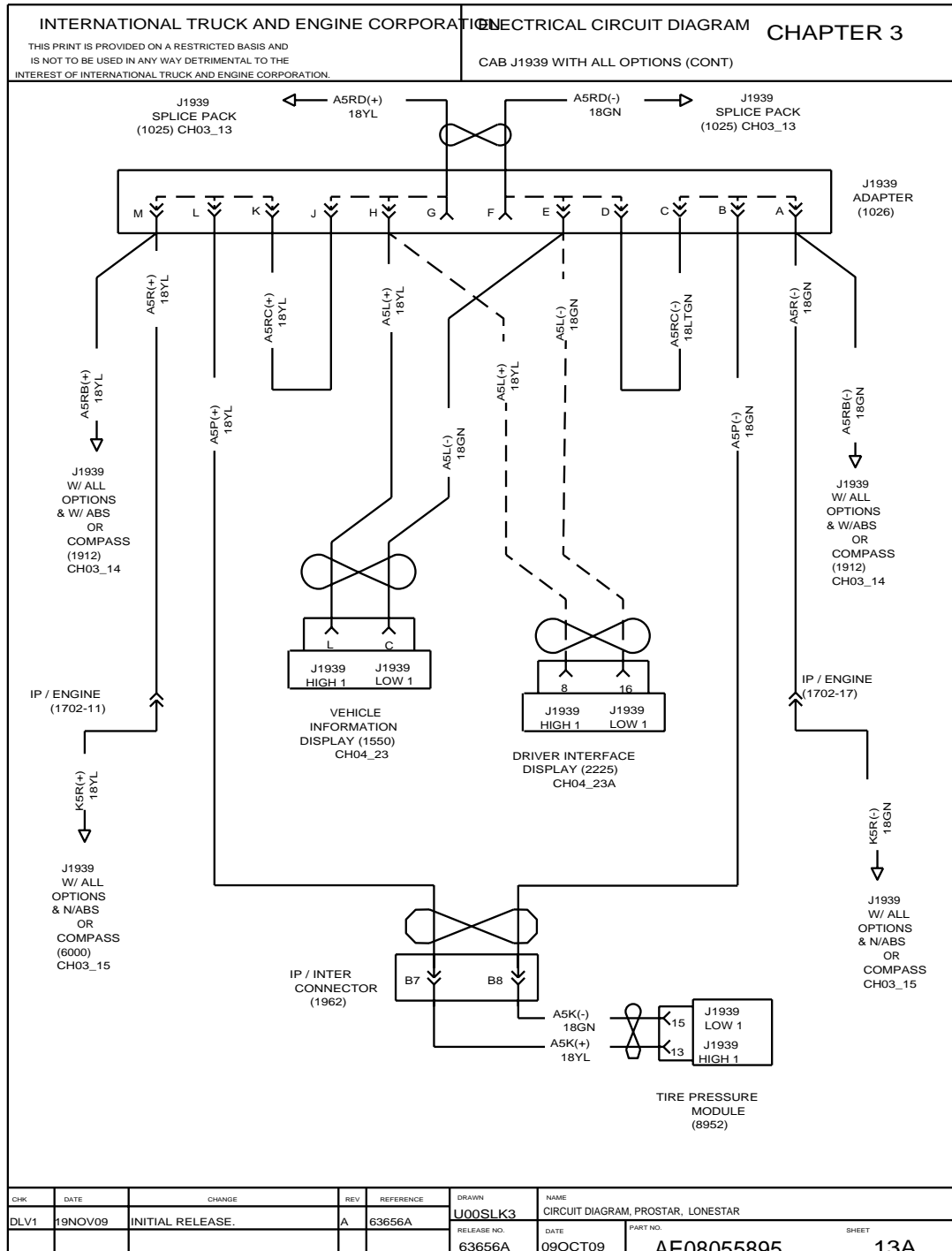


Figure 27 Cab J1939 with All Options

3.16. CAB J1939 WITH ALL OPTIONS, P. 14

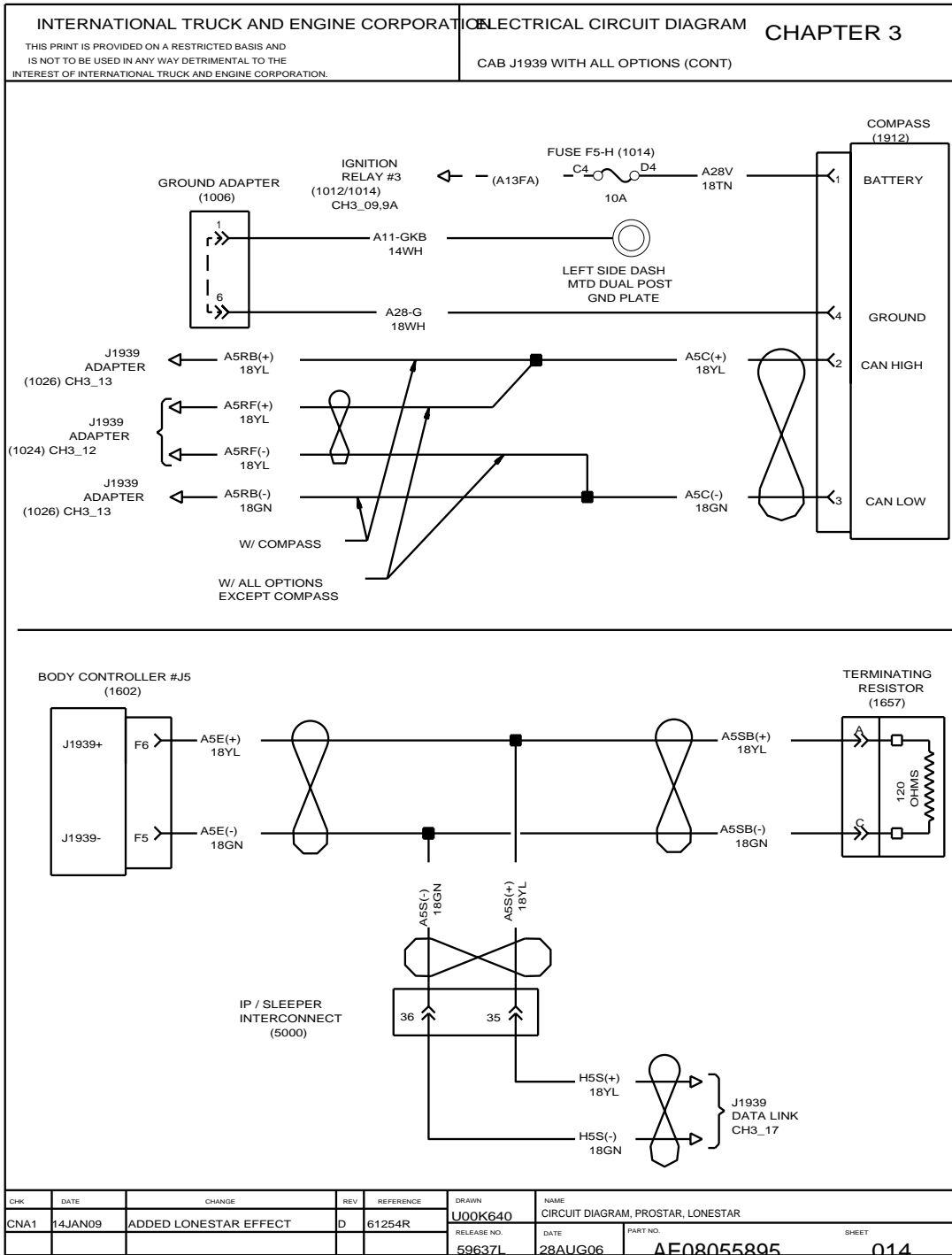


Figure 28 Cab J1939 with All Options

3.17. J1939 ENGINE, P. 15

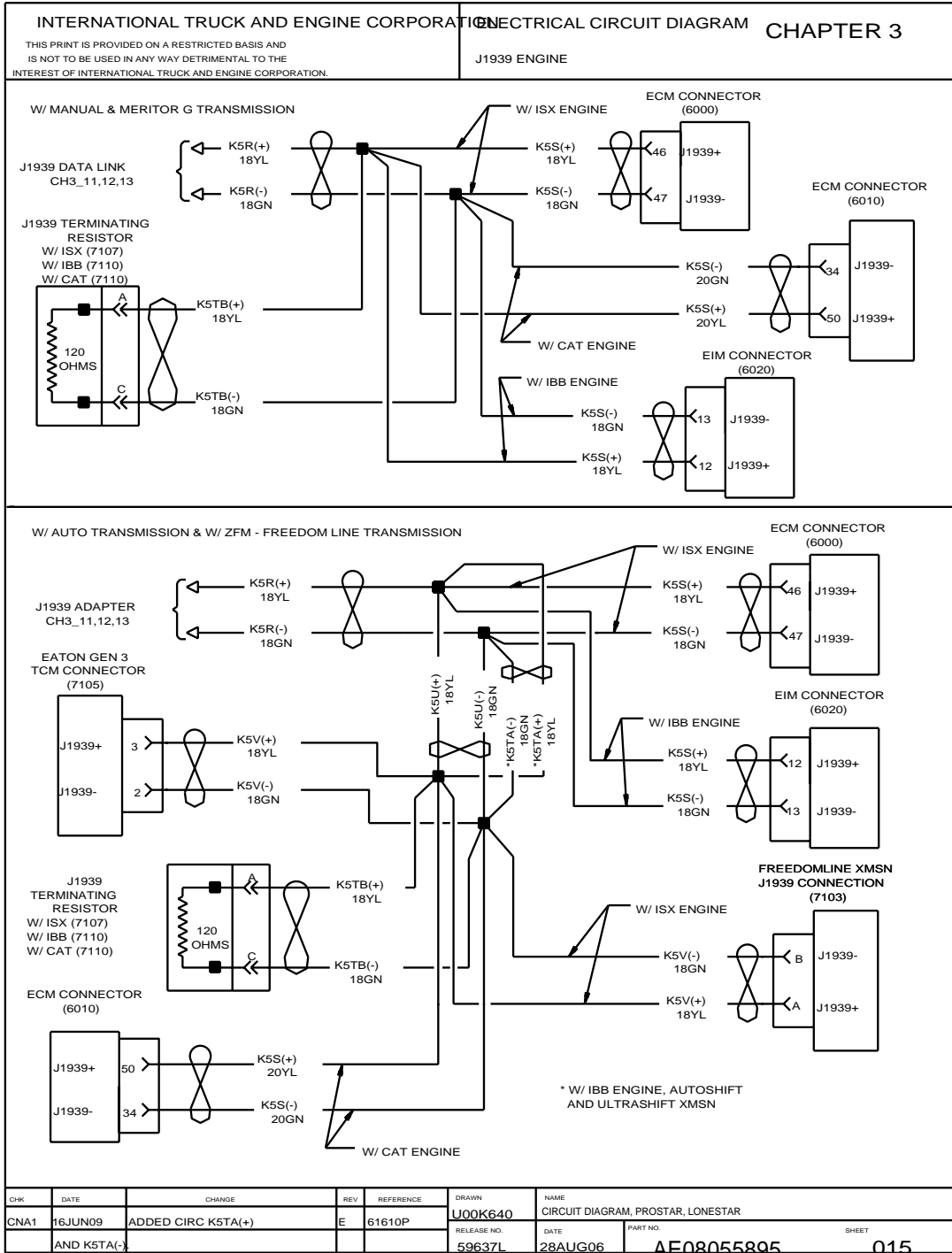


Figure 29 J1939 Engine

3.18. J1939 CHASSIS, P. 16

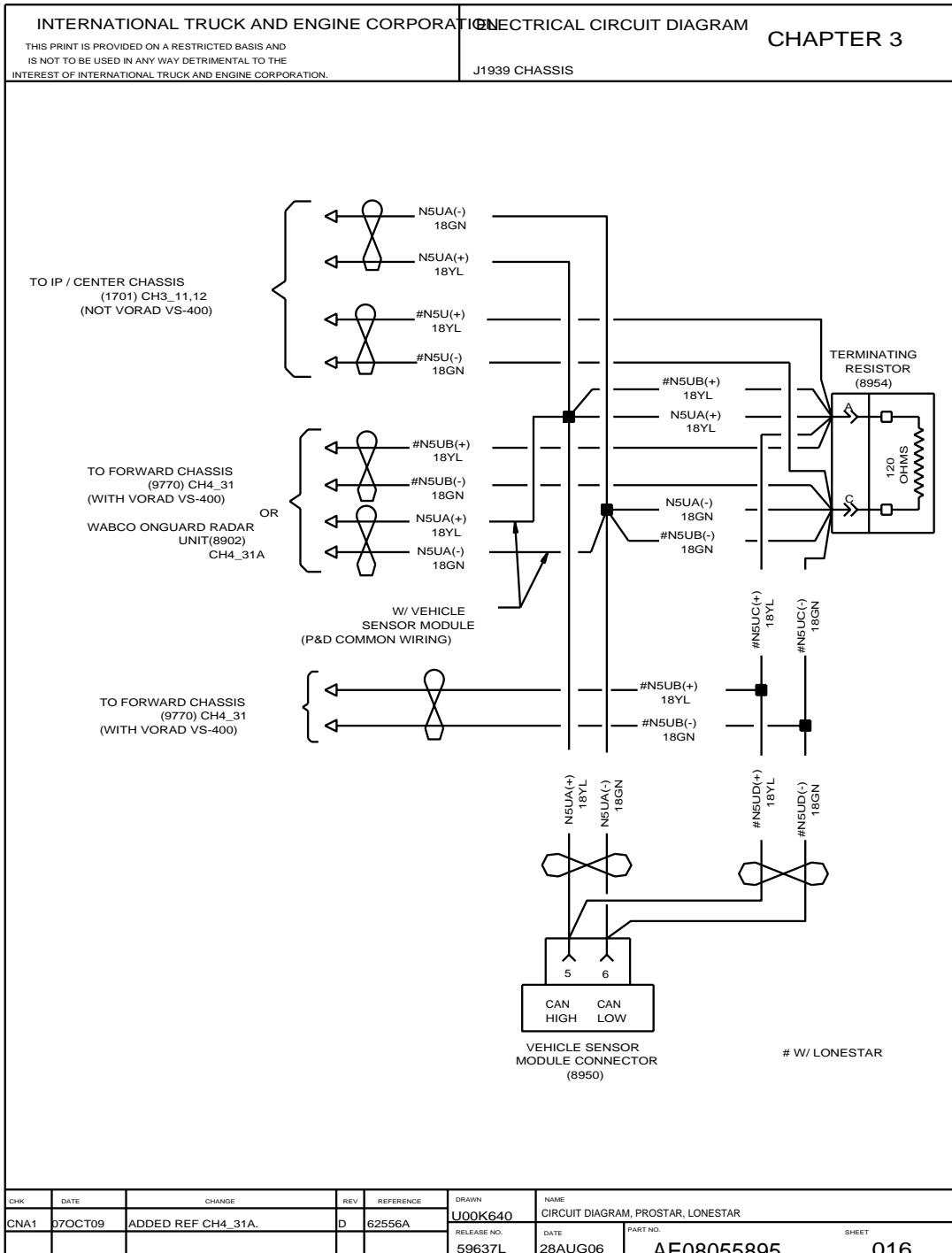


Figure 30 J1939 Chassis

3.19. J1939 WITH SLEEPER, P. 17

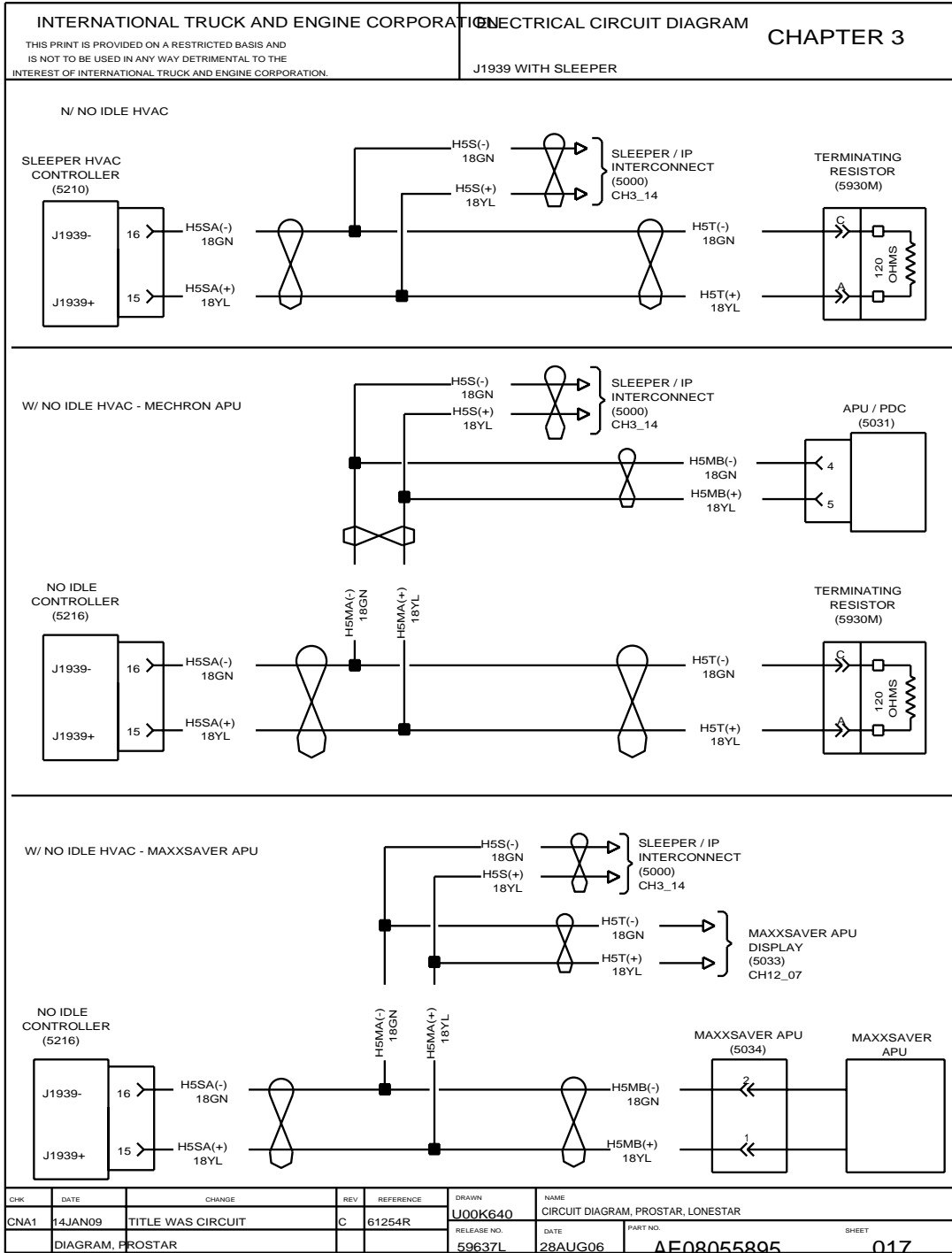


Figure 31 J1939 with Sleeper

3.20. J1708 PRIVATE, P. 18

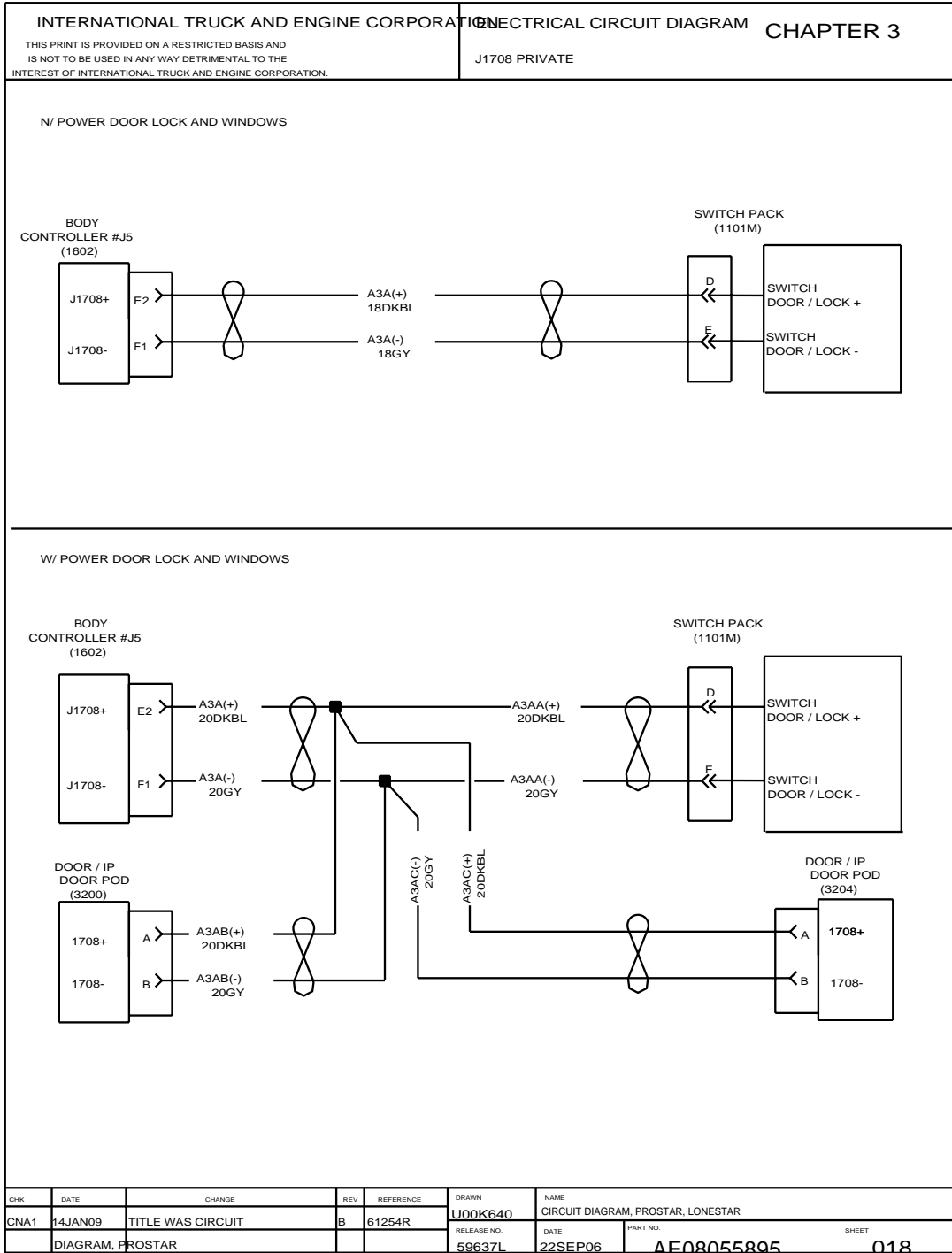


Figure 32 J1708 Private

3.21. J1708 PUBLIC, P. 19

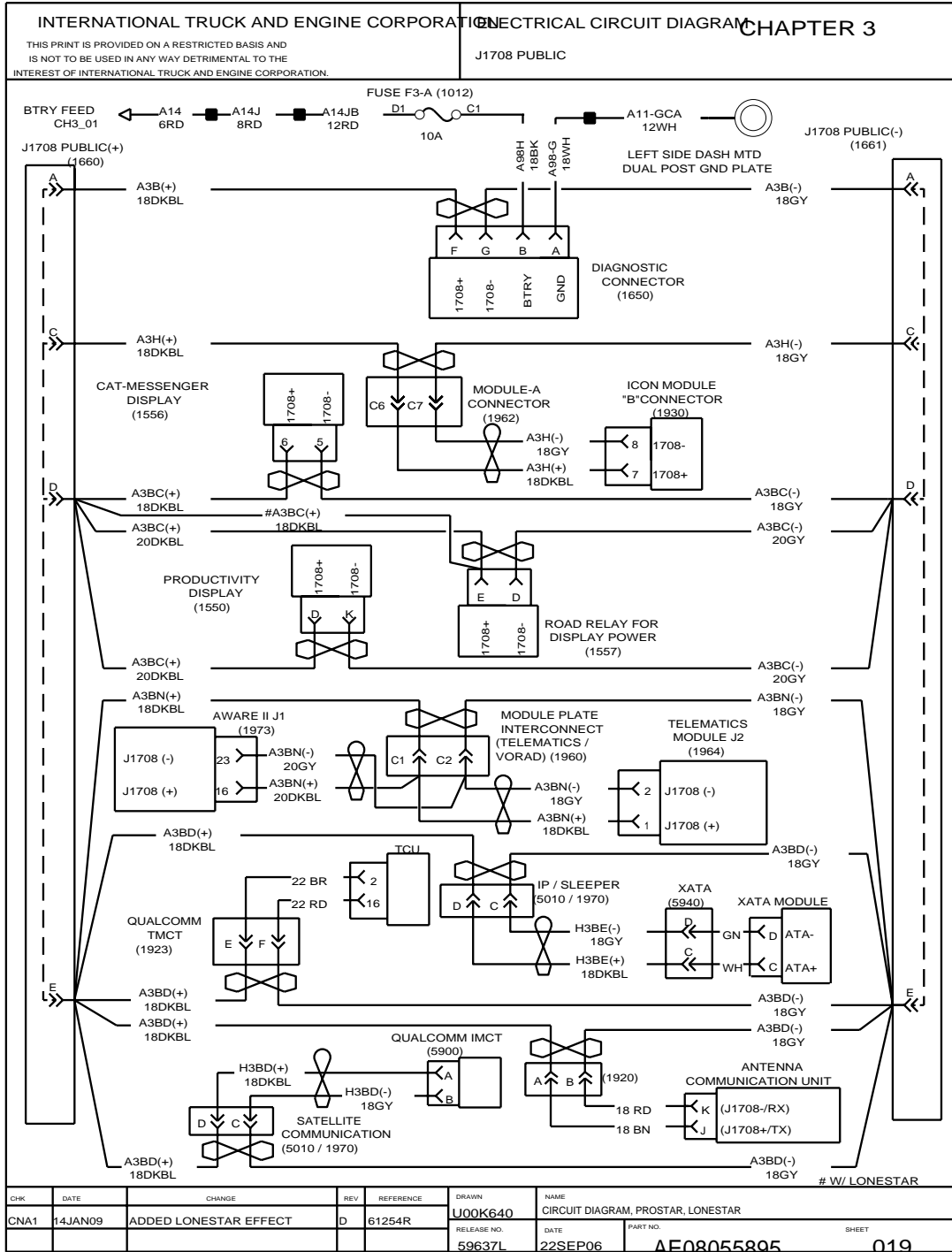


Figure 33 J1708 Public

3.22. J1708 PUBLIC, P. 20

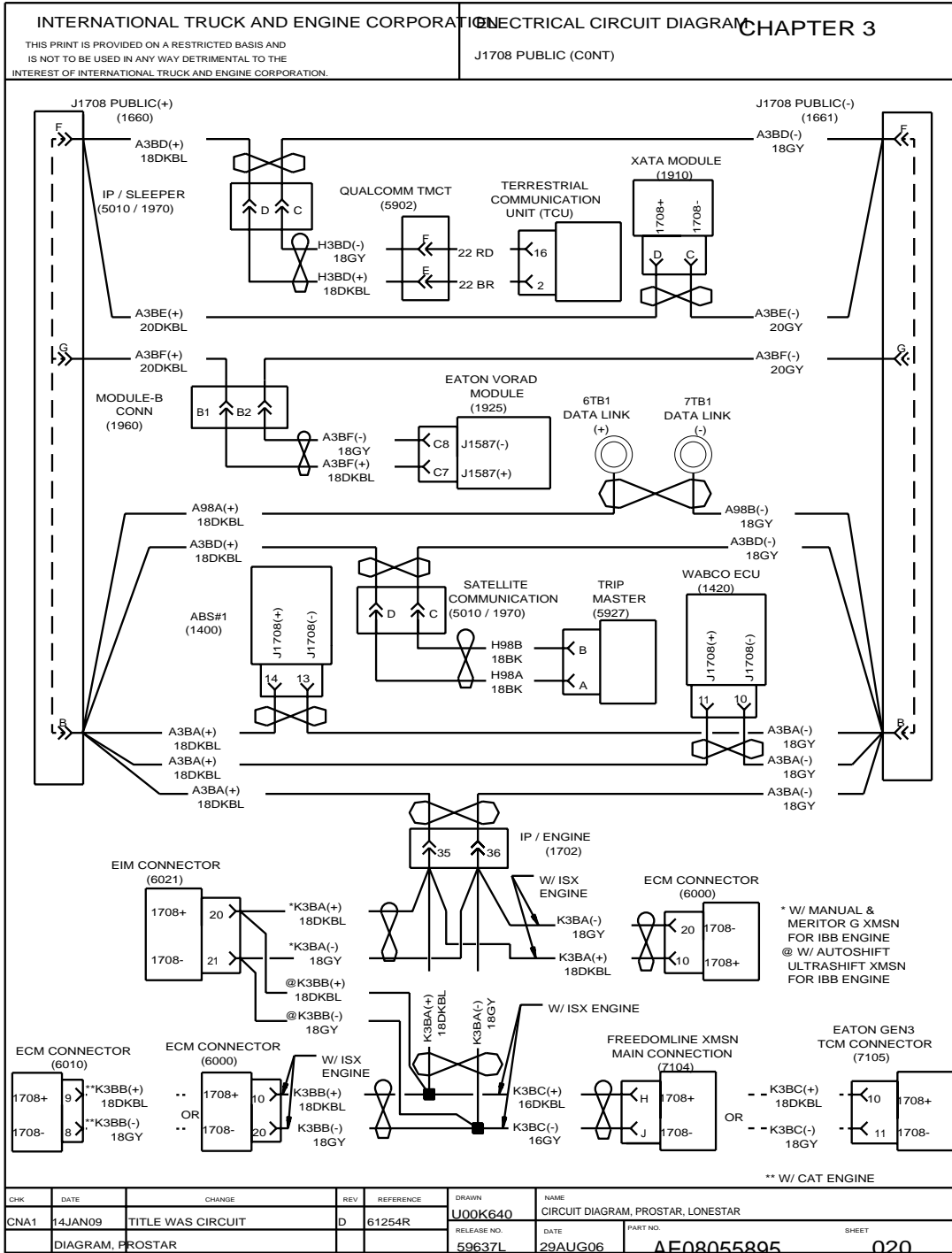


Figure 34 J1708 Public

3.23. J1708 PUBLIC, P. 20A

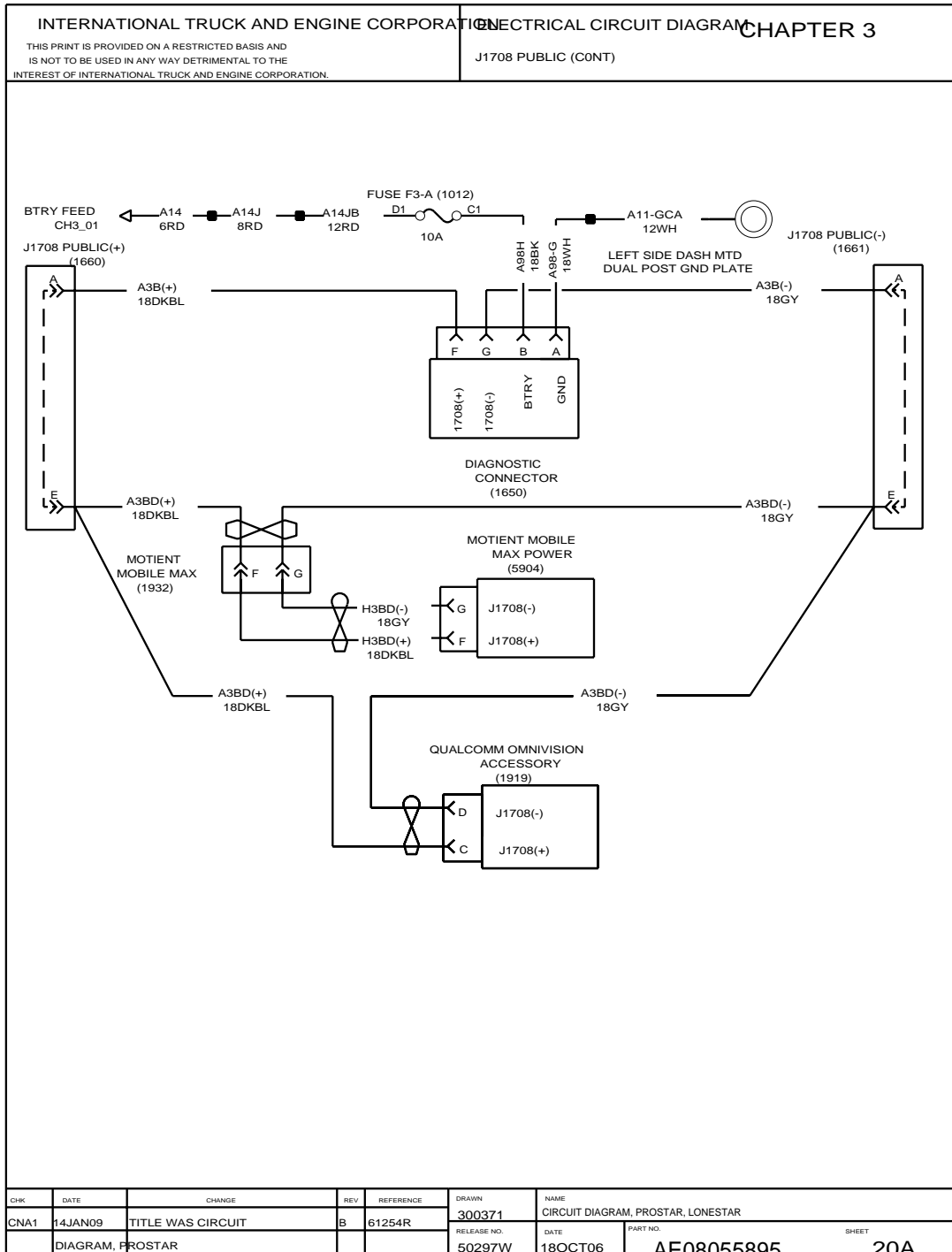


Figure 35 J1708 Public

3.24. GROUND — CAB, P. 21

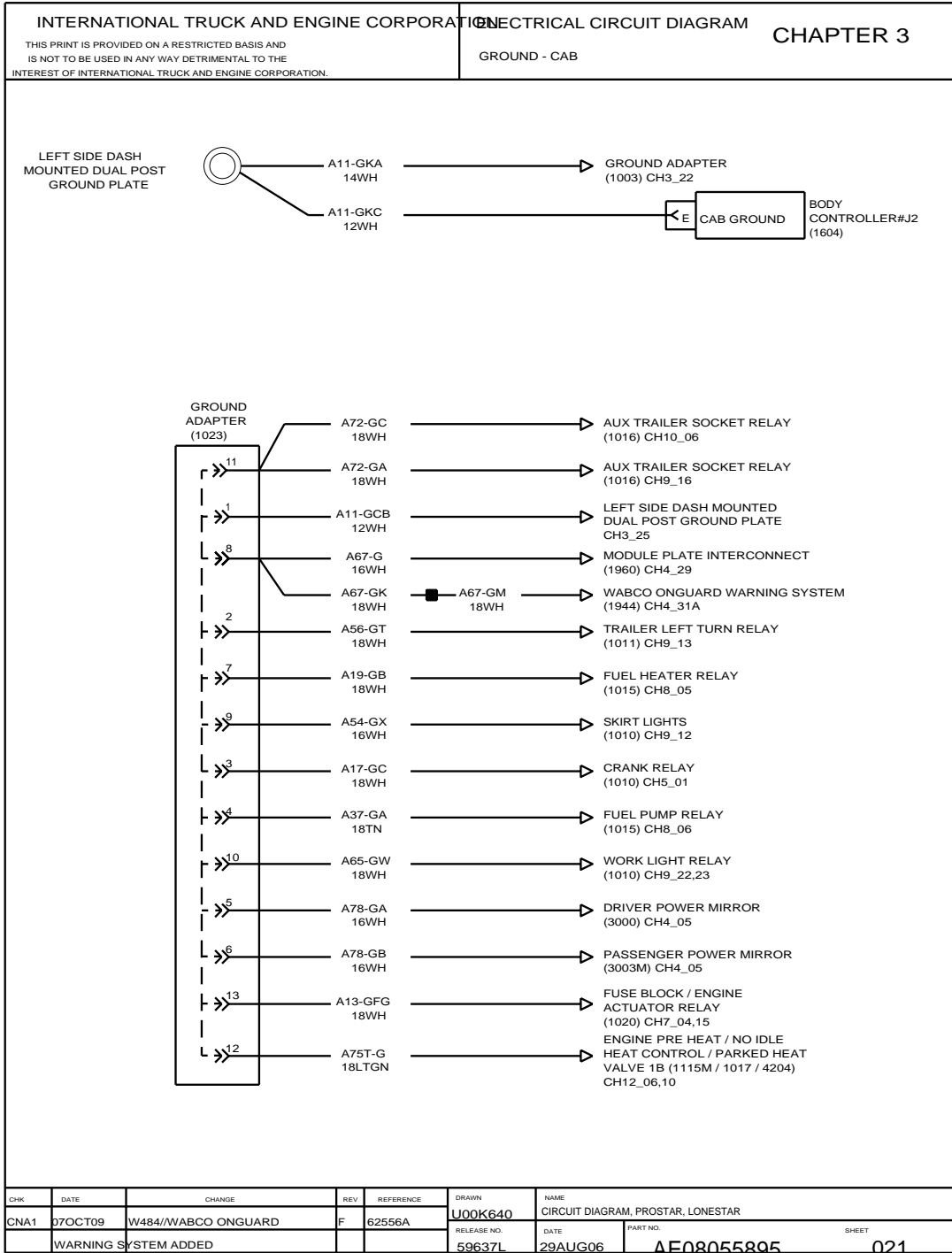


Figure 36 Ground — Cab

3.25. GROUND — CAB, P. 22

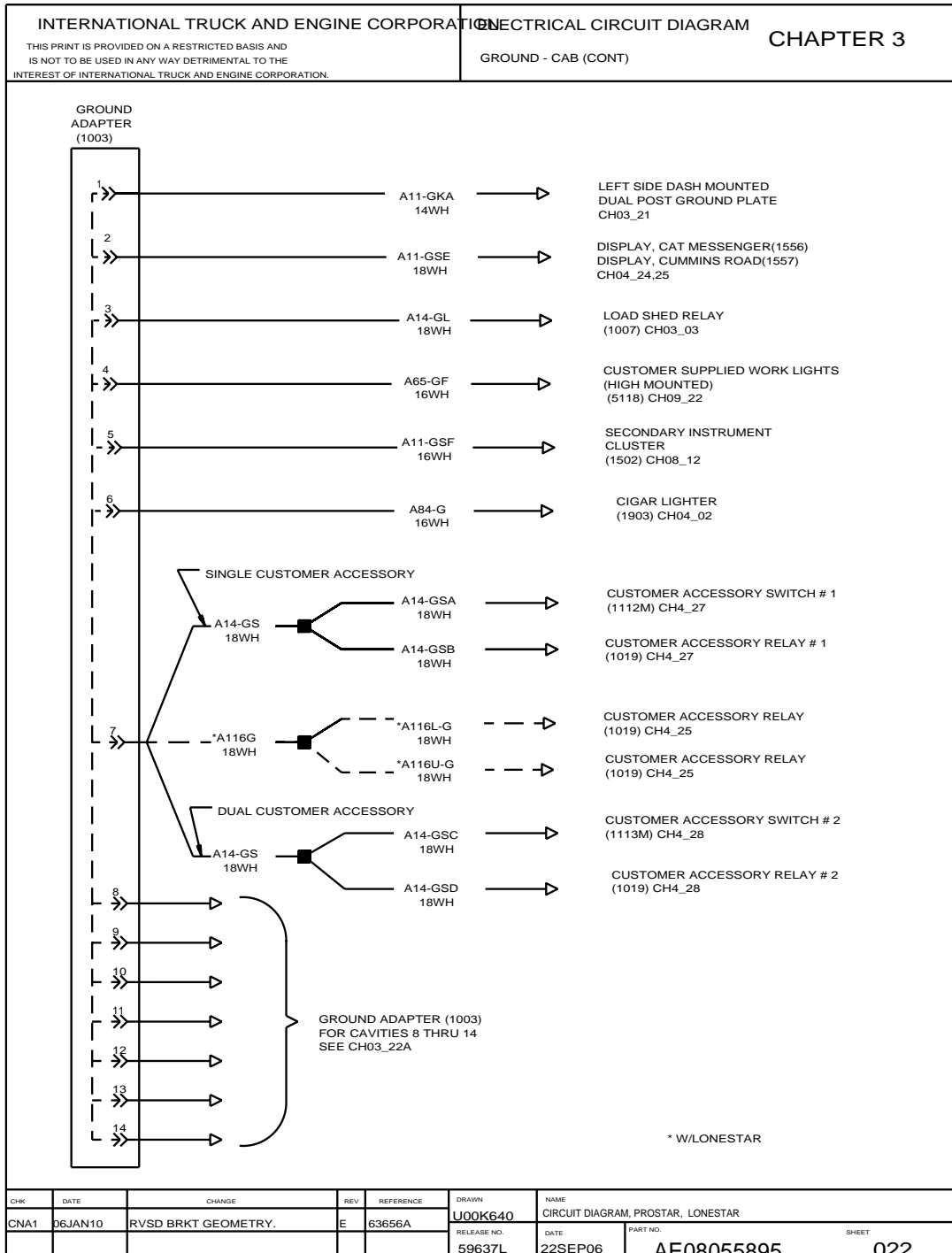


Figure 37 Ground — Cab

3.26. GROUND — CAB, P. 22A

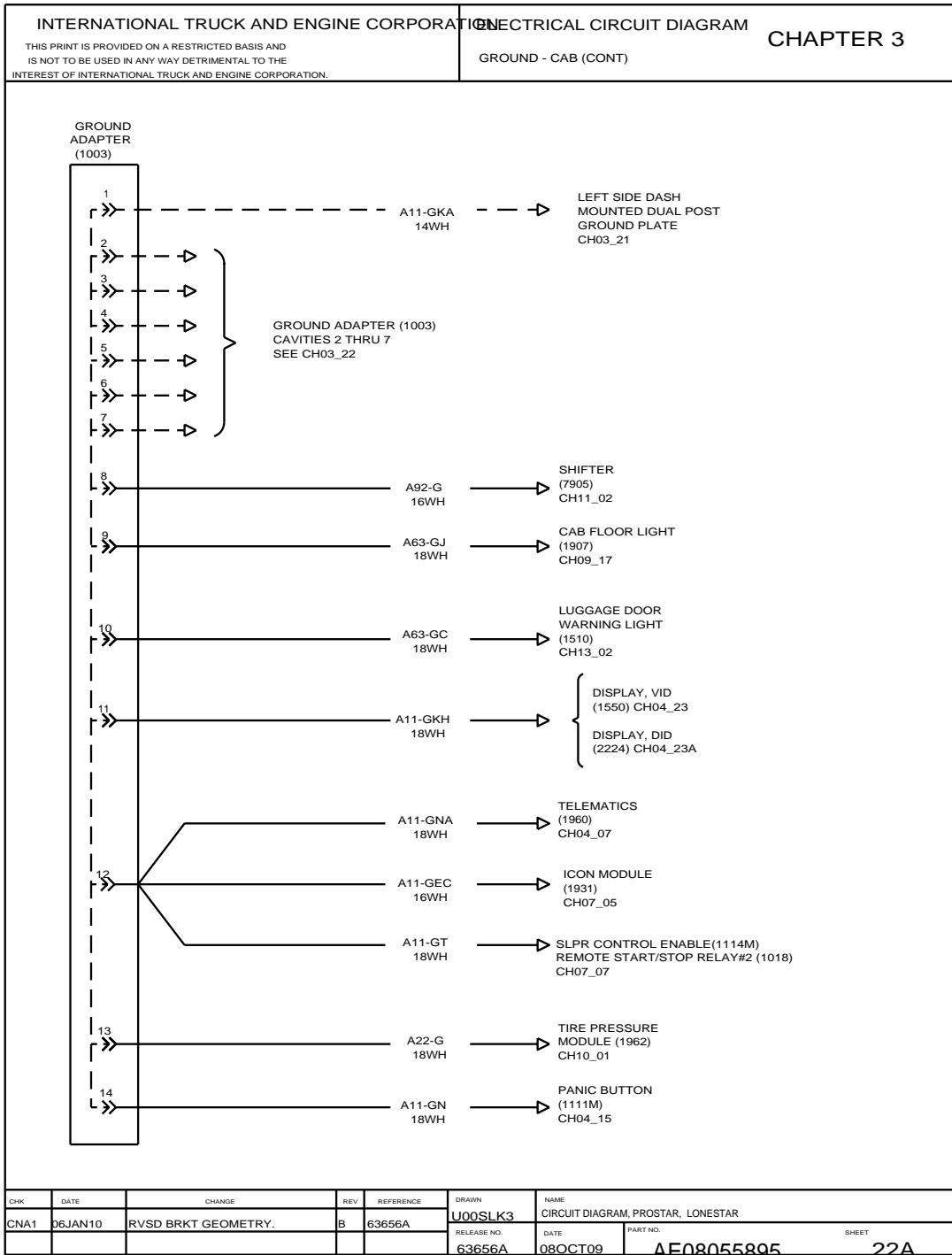


Figure 38 Ground — Cab

3.27. GROUND — CAB, P. 23

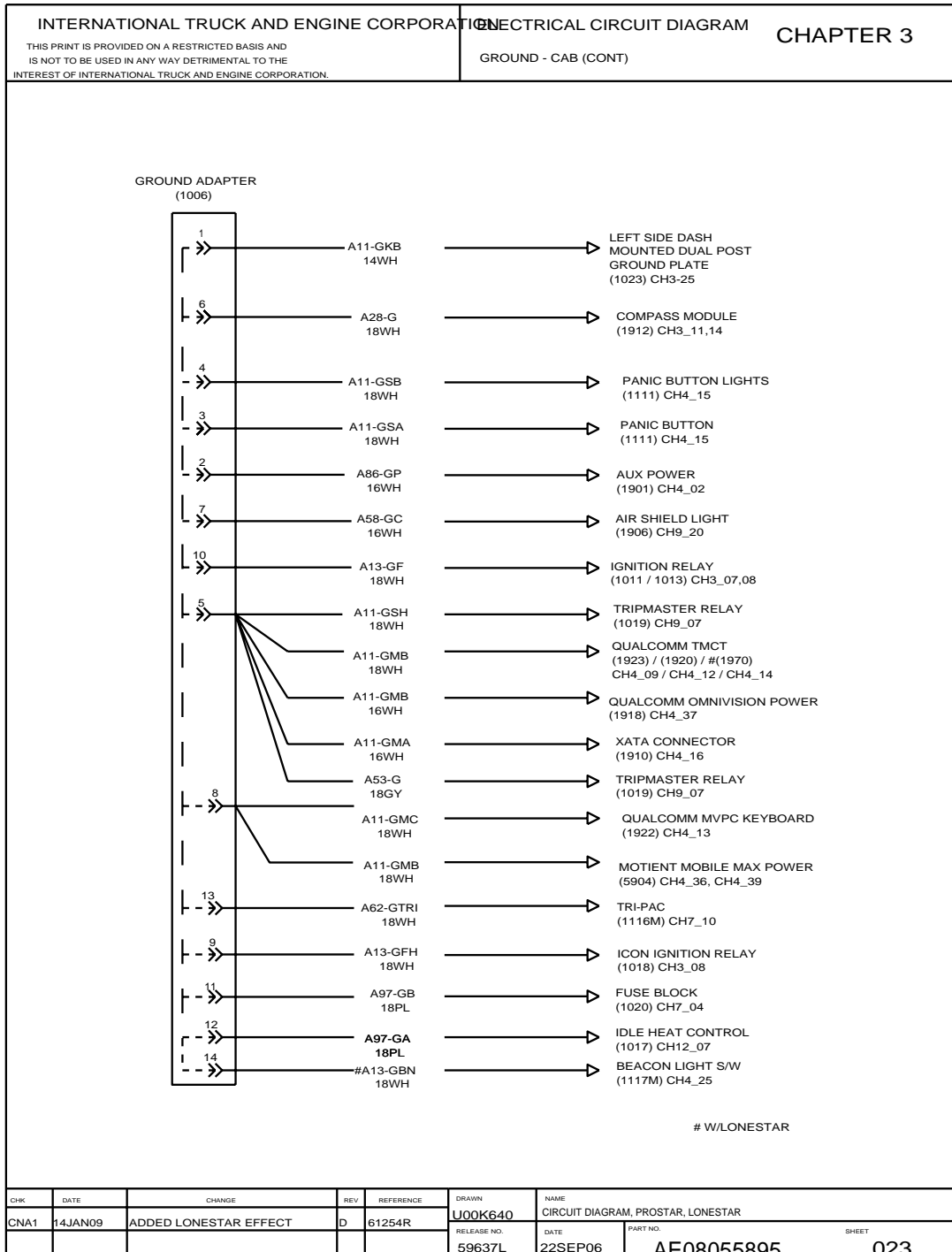


Figure 39 Ground — Cab

3.28. GROUND — CAB, P. 24

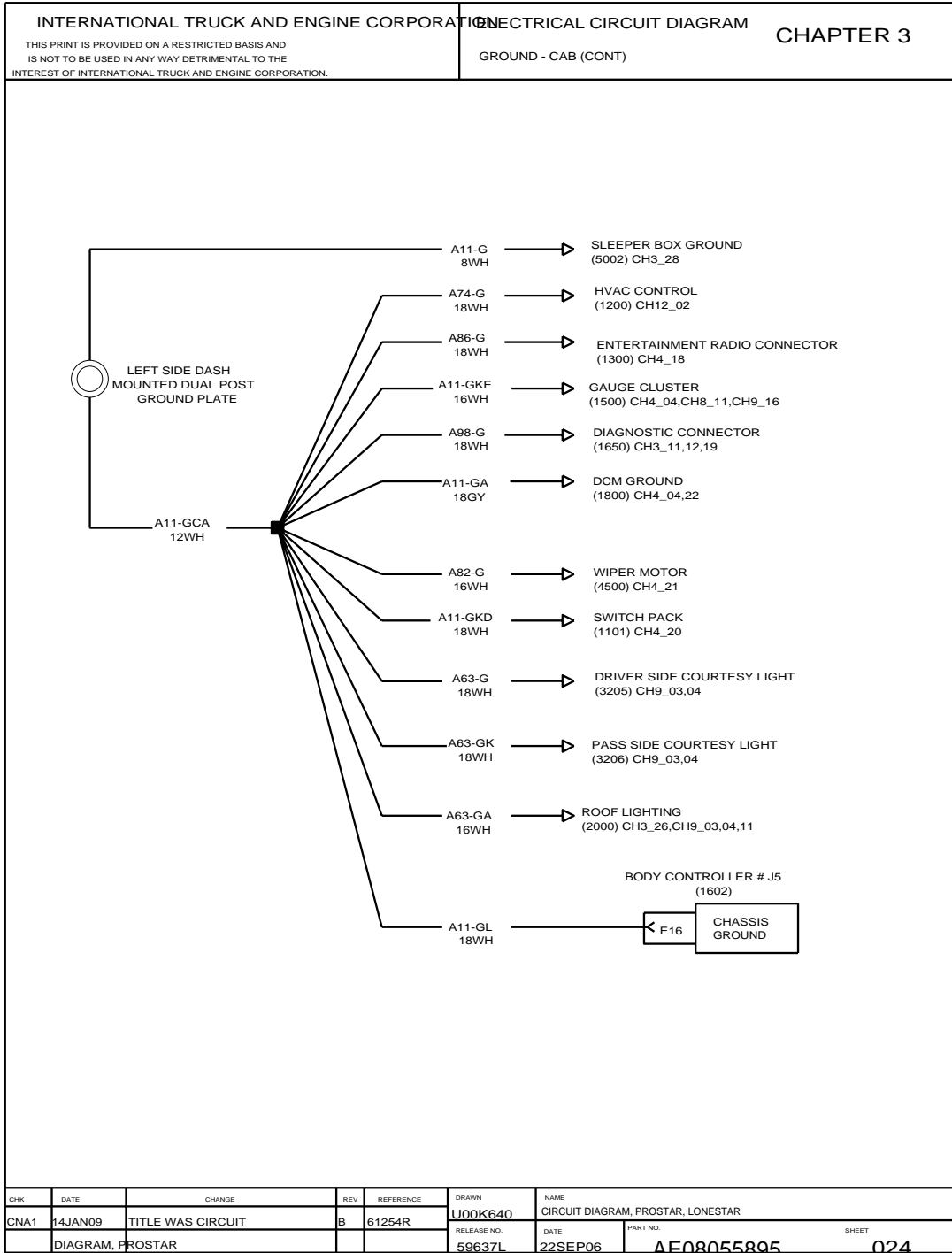


Figure 40 Ground — Cab

3.29. GROUND — CAB, P. 25

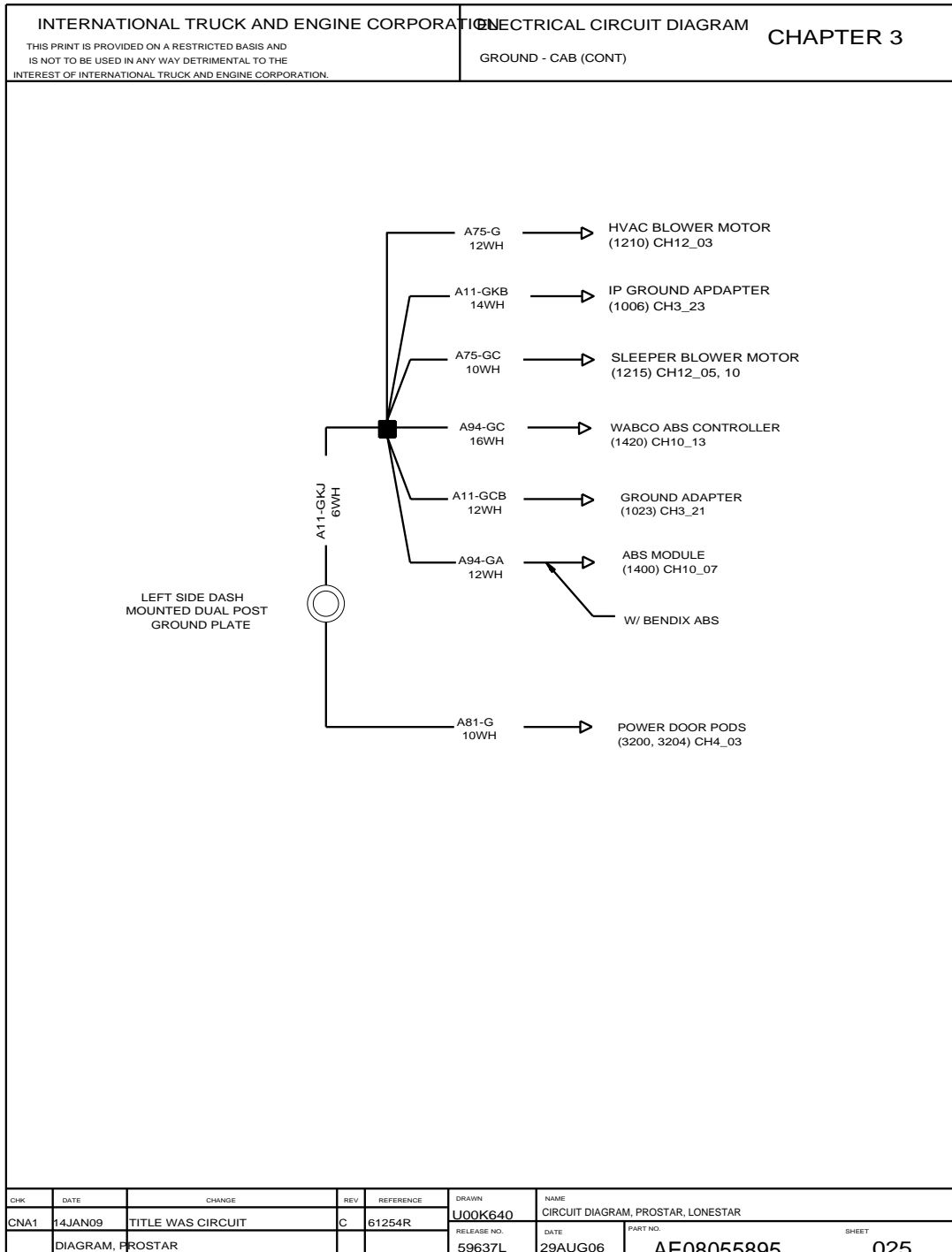


Figure 41 Ground — Cab

3.30. GROUND — CAB, P. 26

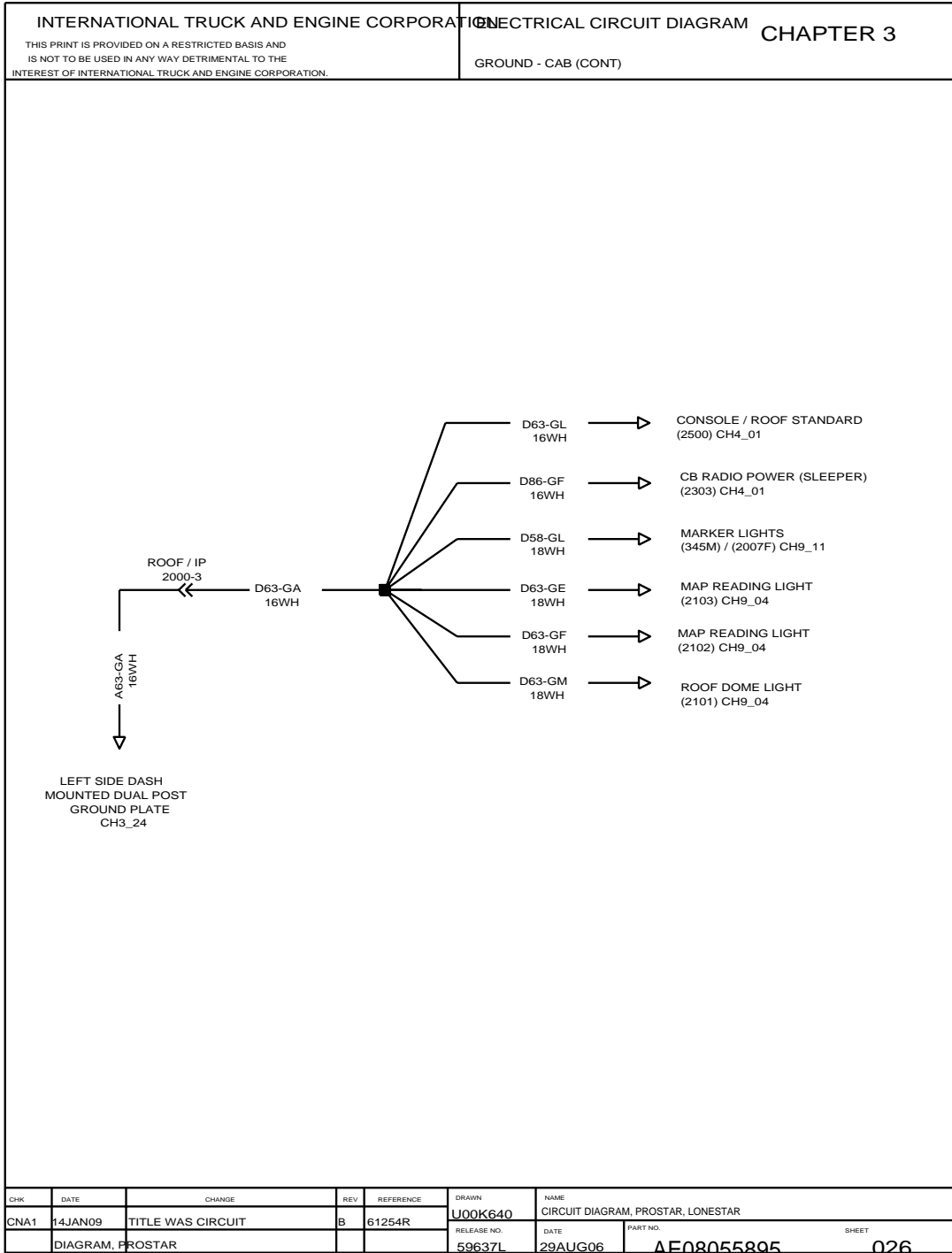


Figure 42 Ground — Cab

3.31. GROUND — CHASSIS, P. 27

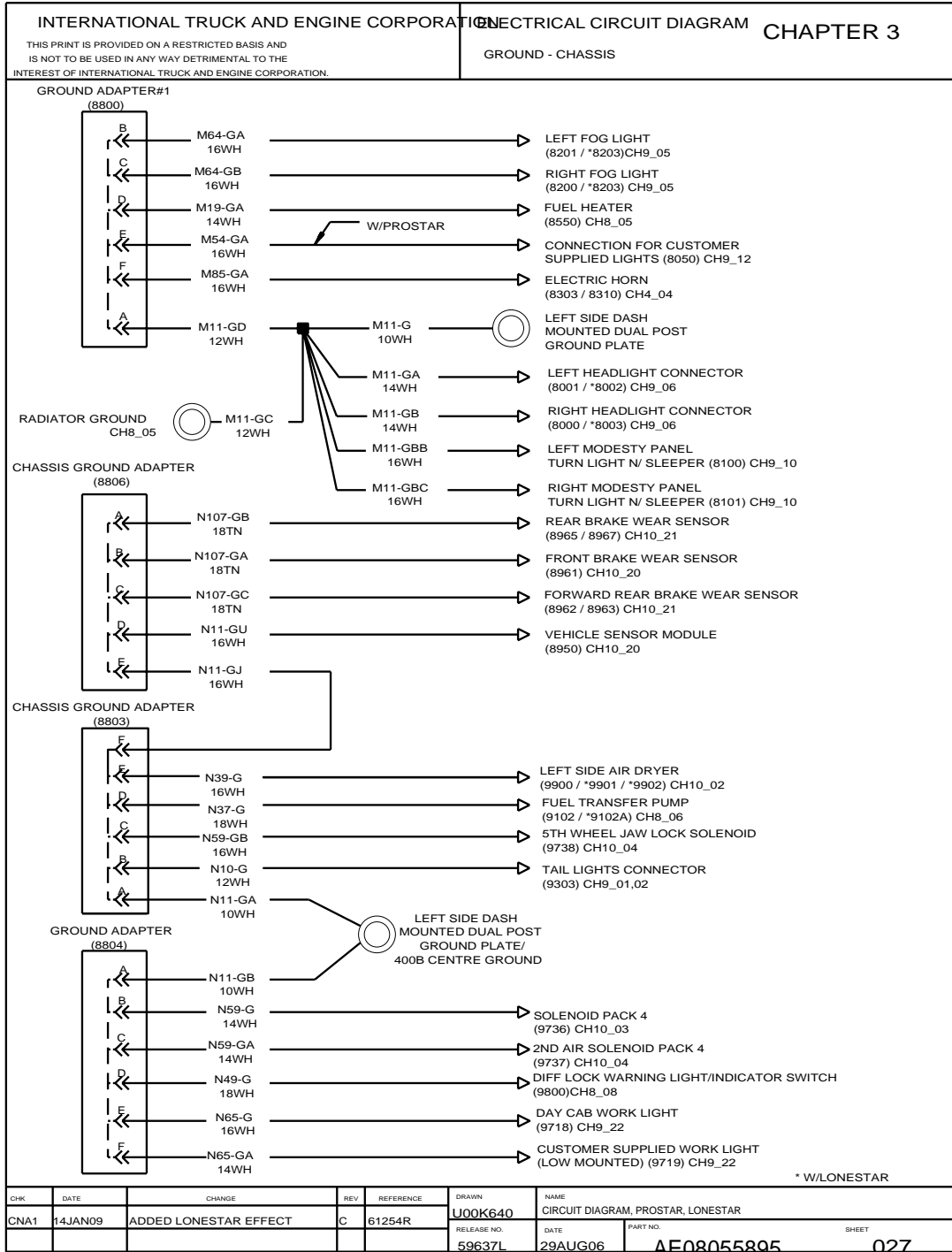


Figure 43 Ground — Chassis

3.32. GROUND — SLEEPER, P. 28

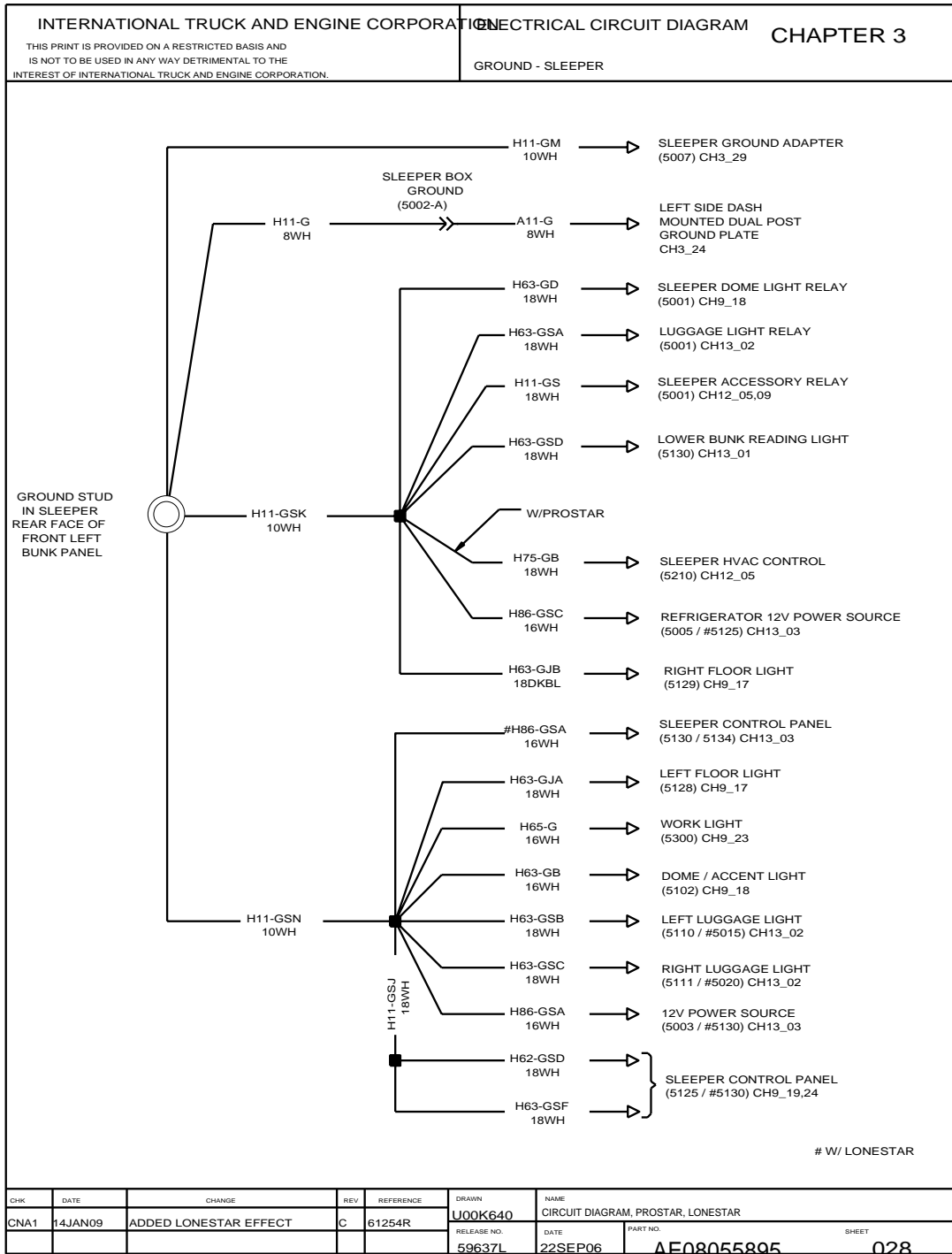


Figure 44 Ground — Sleeper

3.33. GROUND — SLEEPER, P. 29

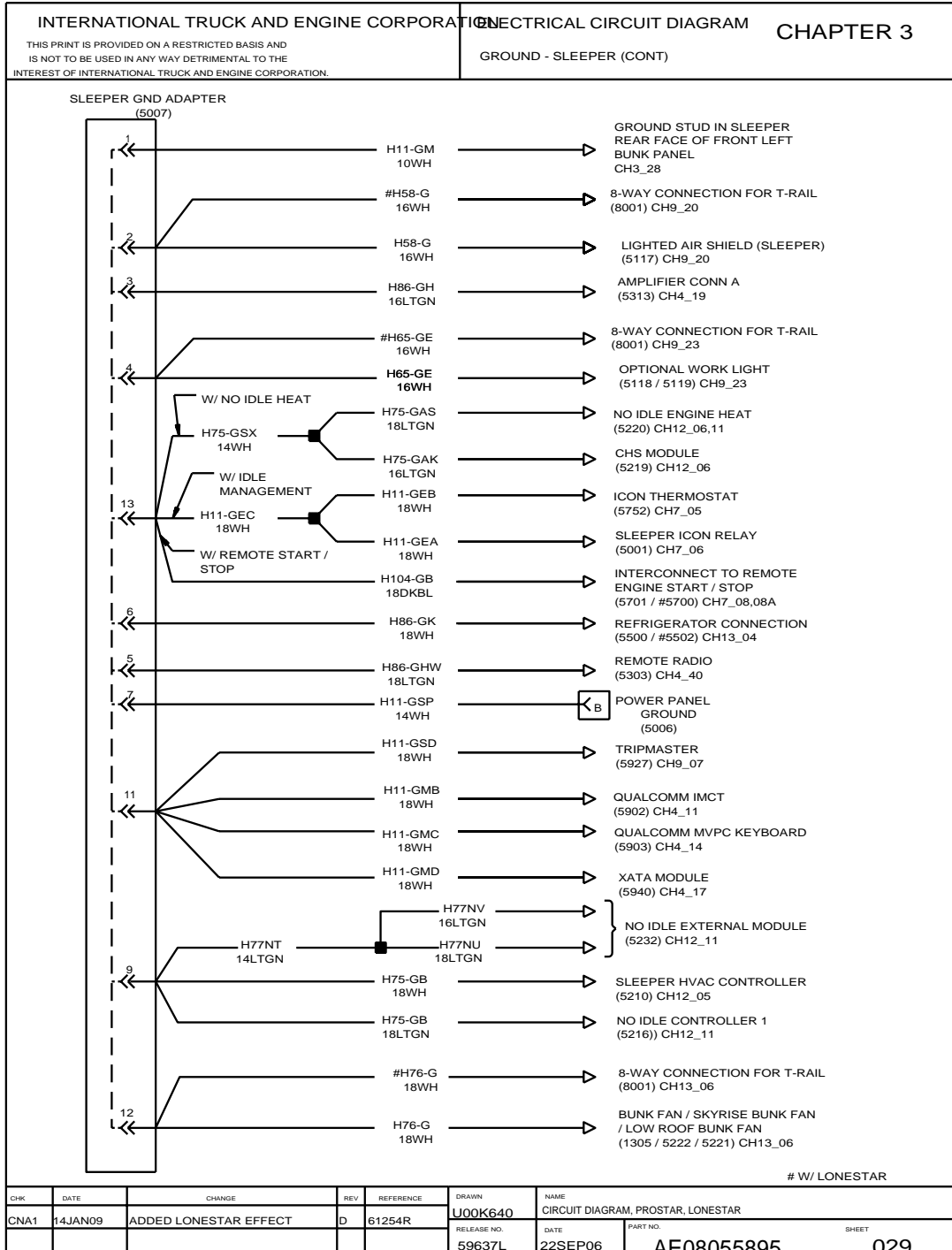


Figure 45 Ground — Sleeper

3.34. GROUND — SLEEPER, P. 29A

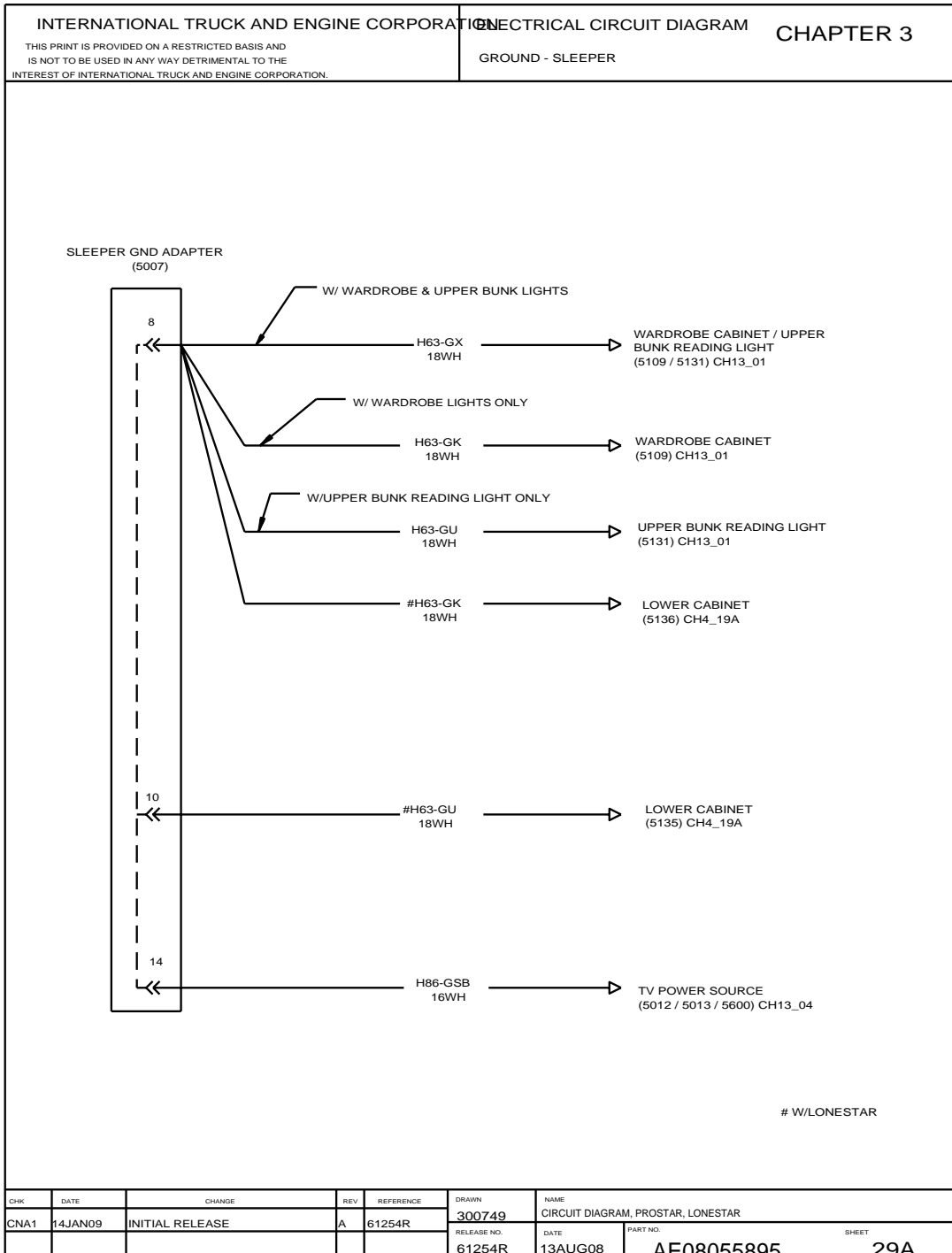


Figure 46 Ground — Sleeper

3.35. ENGINE GROUND — IBB ENGINE, P. 30

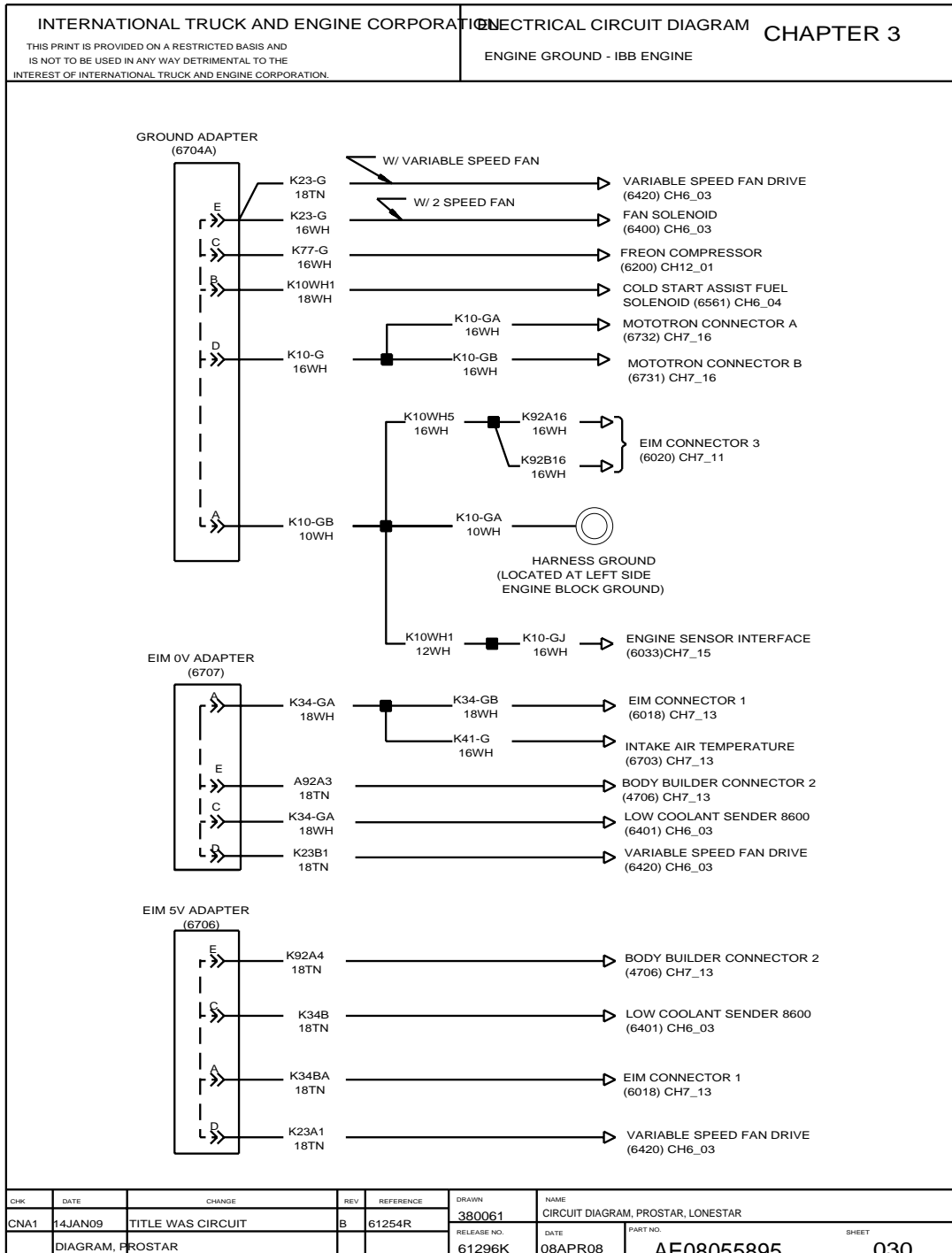


Figure 47 Engine Ground — IBB Engine

3.36. J1939 DATA LINK — IBB ENGINE, P. 31

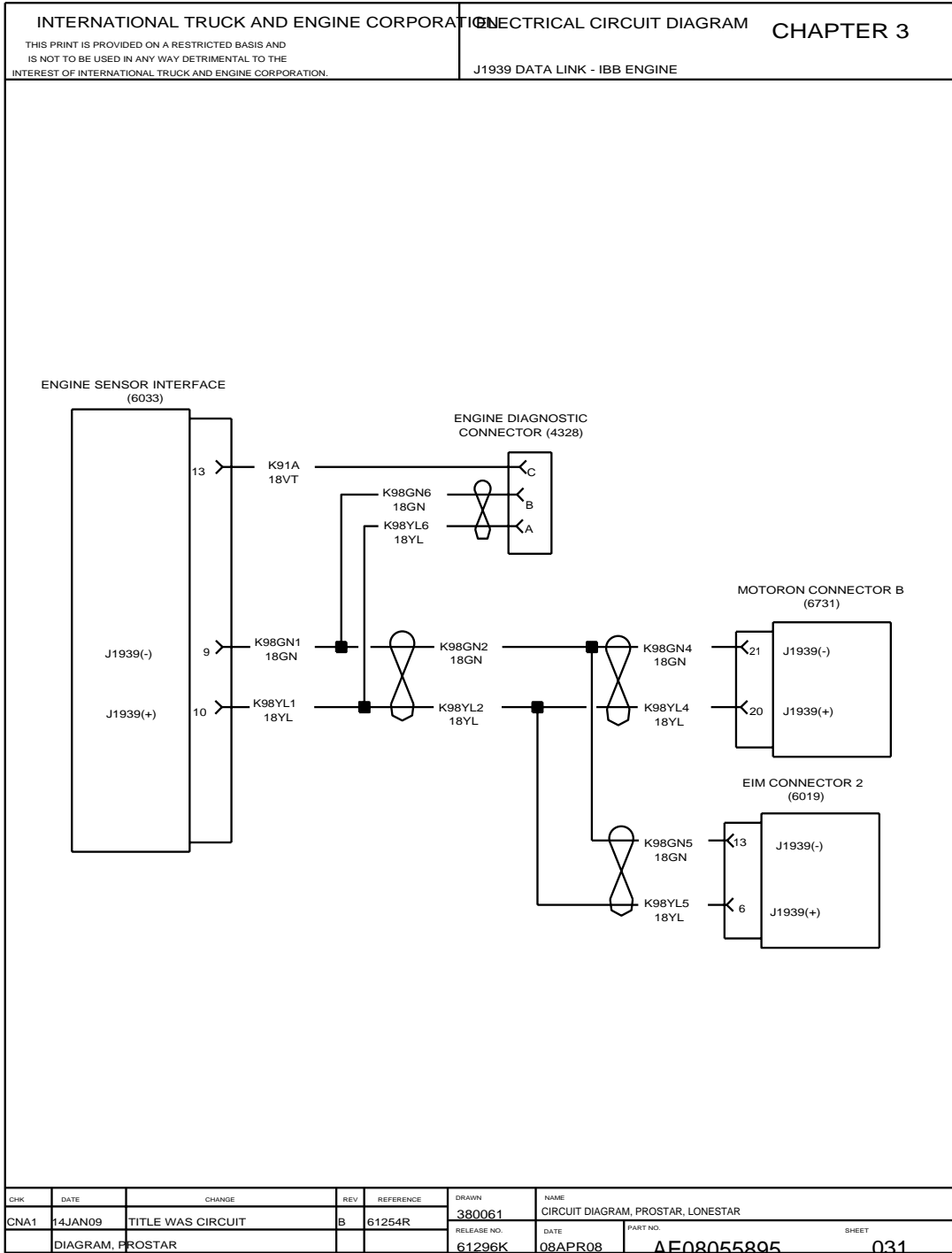


Figure 48 J1939 Data Link — IBB Engine

CHK	DATE	CHANGE	REV	REFERENCE	DRAWN	NAME
CNA1	14JAN09	TITLE WAS CIRCUIT	B	61254R	380061	CIRCUIT DIAGRAM, PROSTAR, LONESTAR
		DIAGRAM, PROSTAR			61296K	08APR08
						PART NO. AE08055895
						SHEET 031

3.37. ZERO VOLT REFERENCE, P. 32

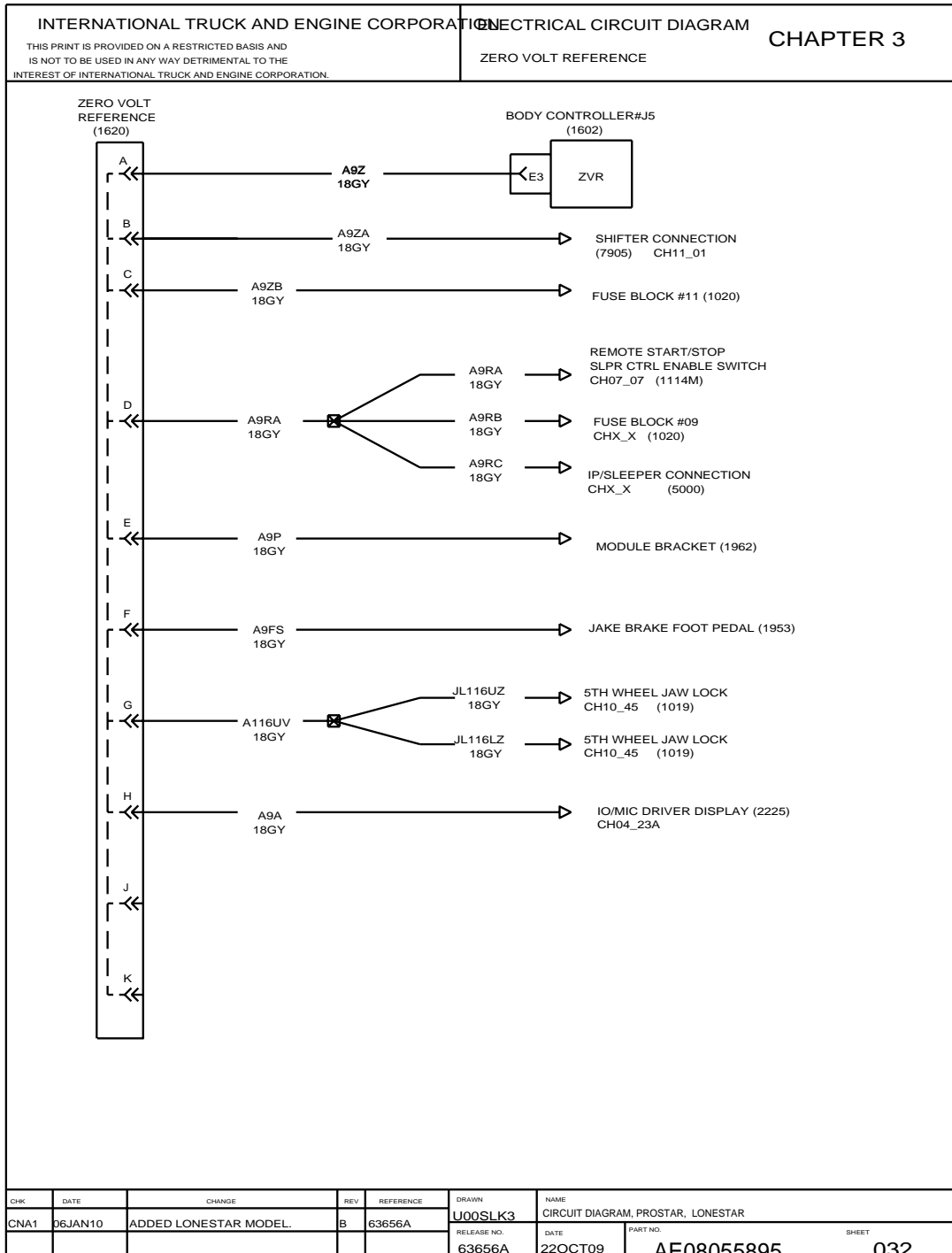


Figure 49 Zero Volt Reference

3.38. ZERO VOLT REFERENCE, P. 32A

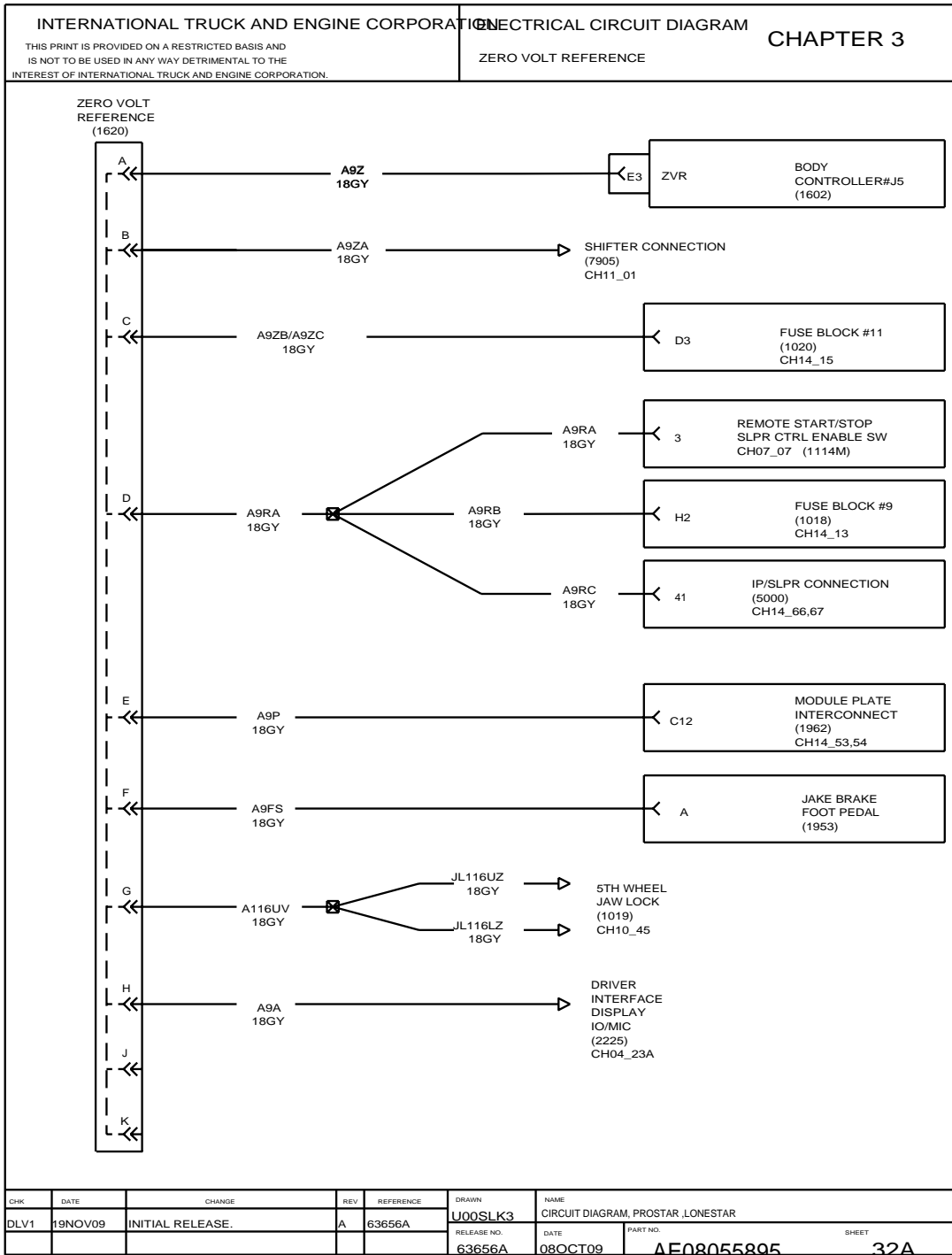


Figure 50 Zero Volt Reference

## 4. CAB ACCESSORIES (CHAPTER 4)

### 4.1. CB POWER RADIO, P. 1

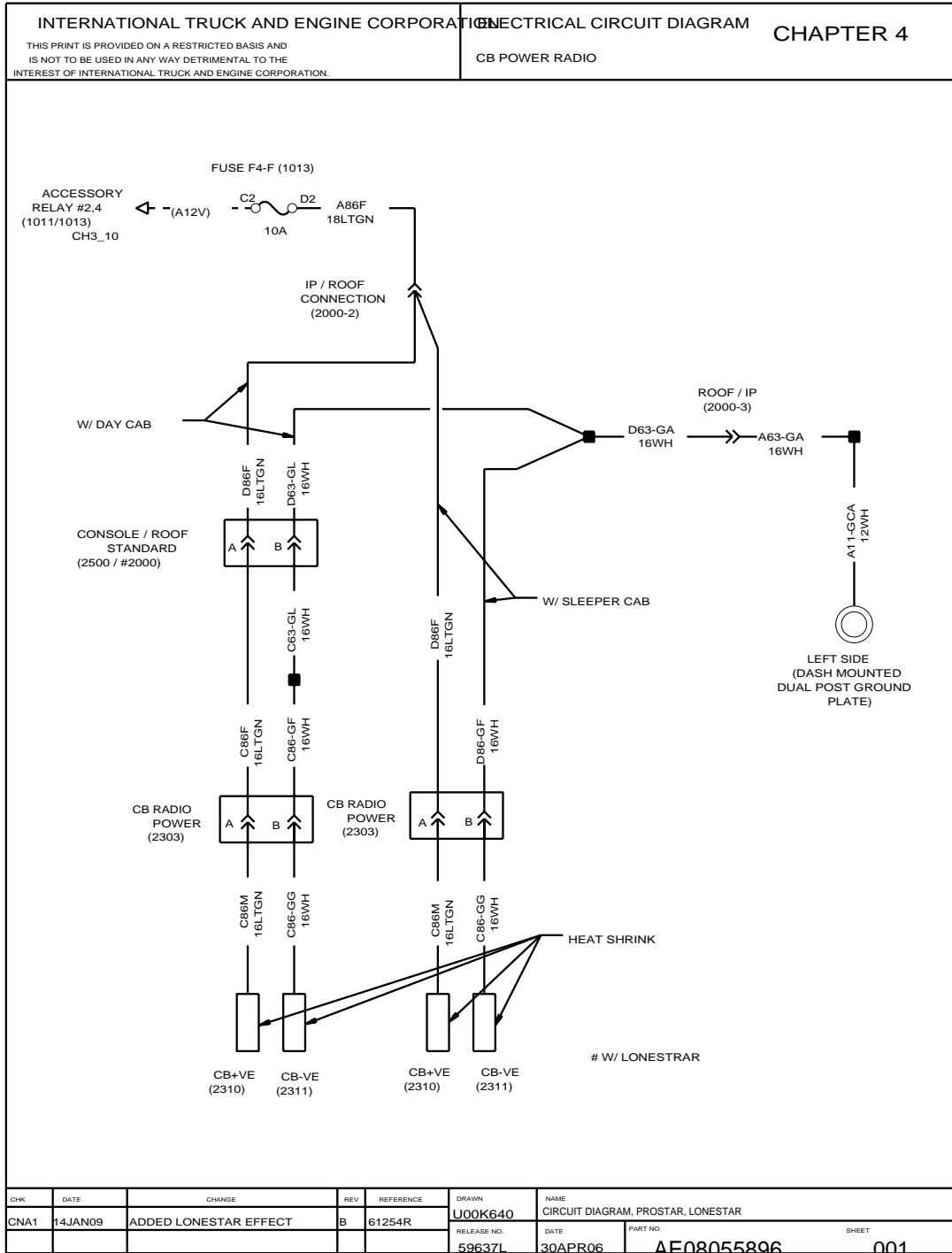


Figure 51 CB Power Radio

4.2. CIGAR LIGHTER AND TEMPERATURE DISPLAY, P. 2

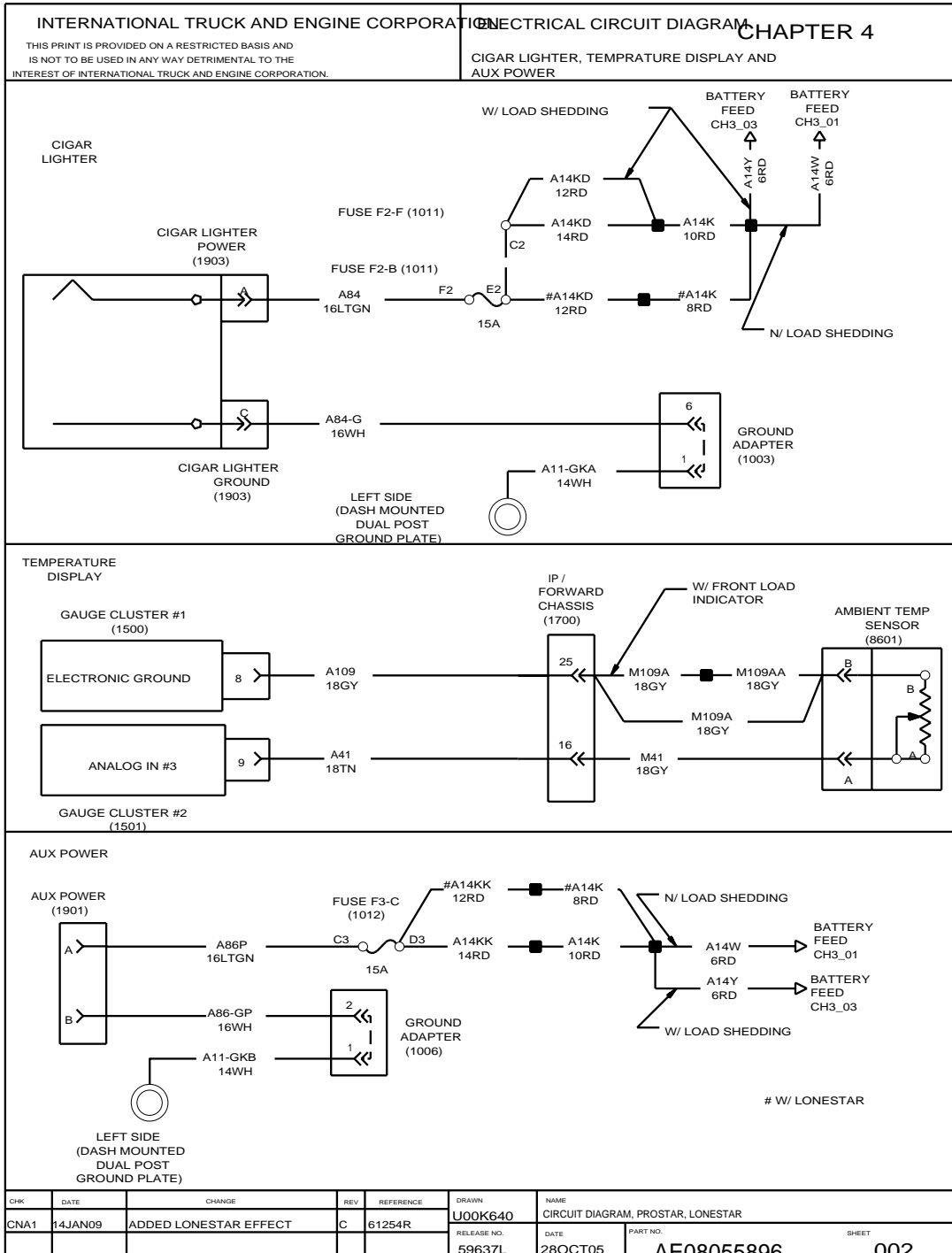


Figure 52 Cigar Lighter and Temperature Display

4.3. ELECTRIC WINDOWS AND DOOR LOCKS, P. 3

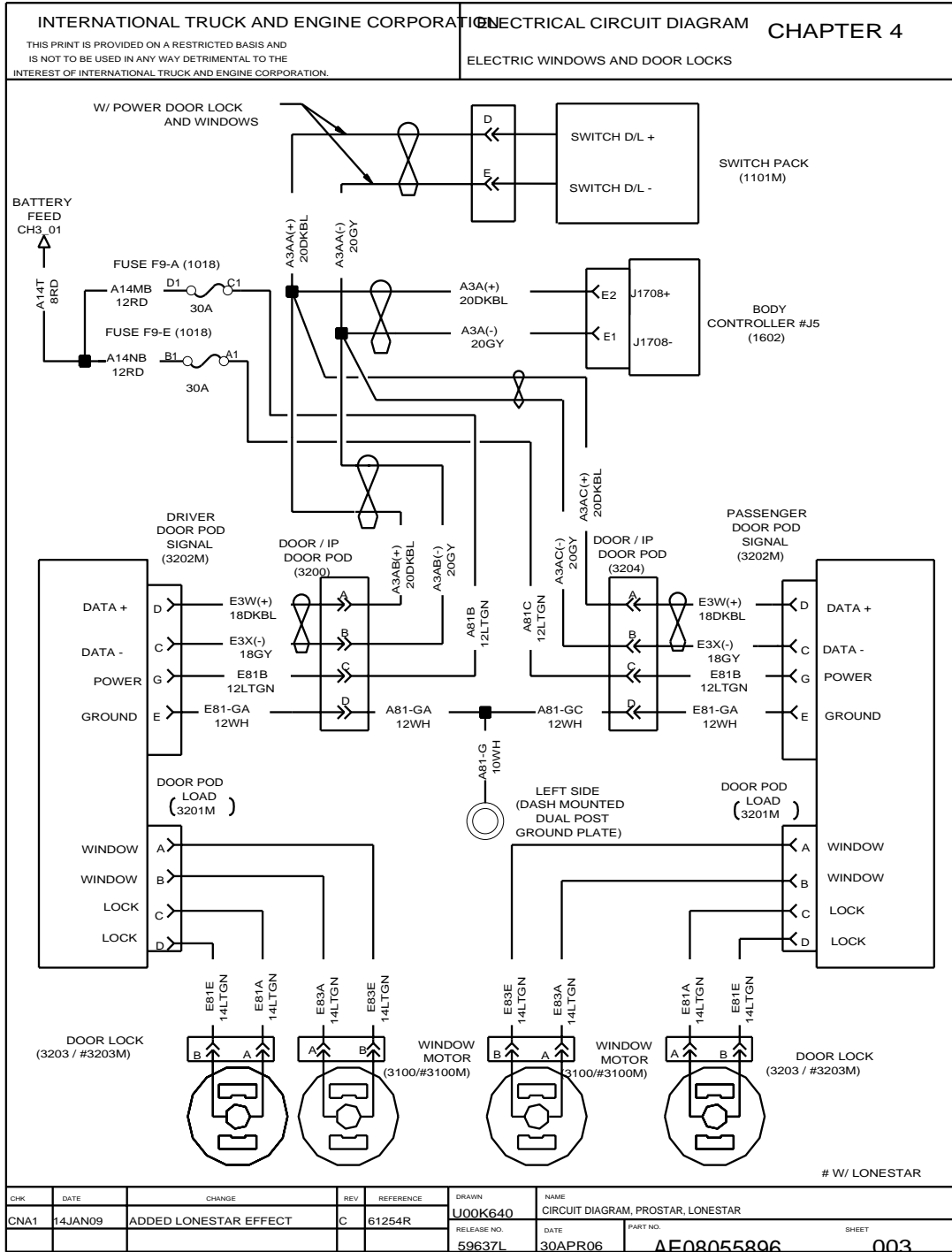


Figure 53 Electric Windows and Door Locks

4.4. ELECTRIC HORN, P. 4

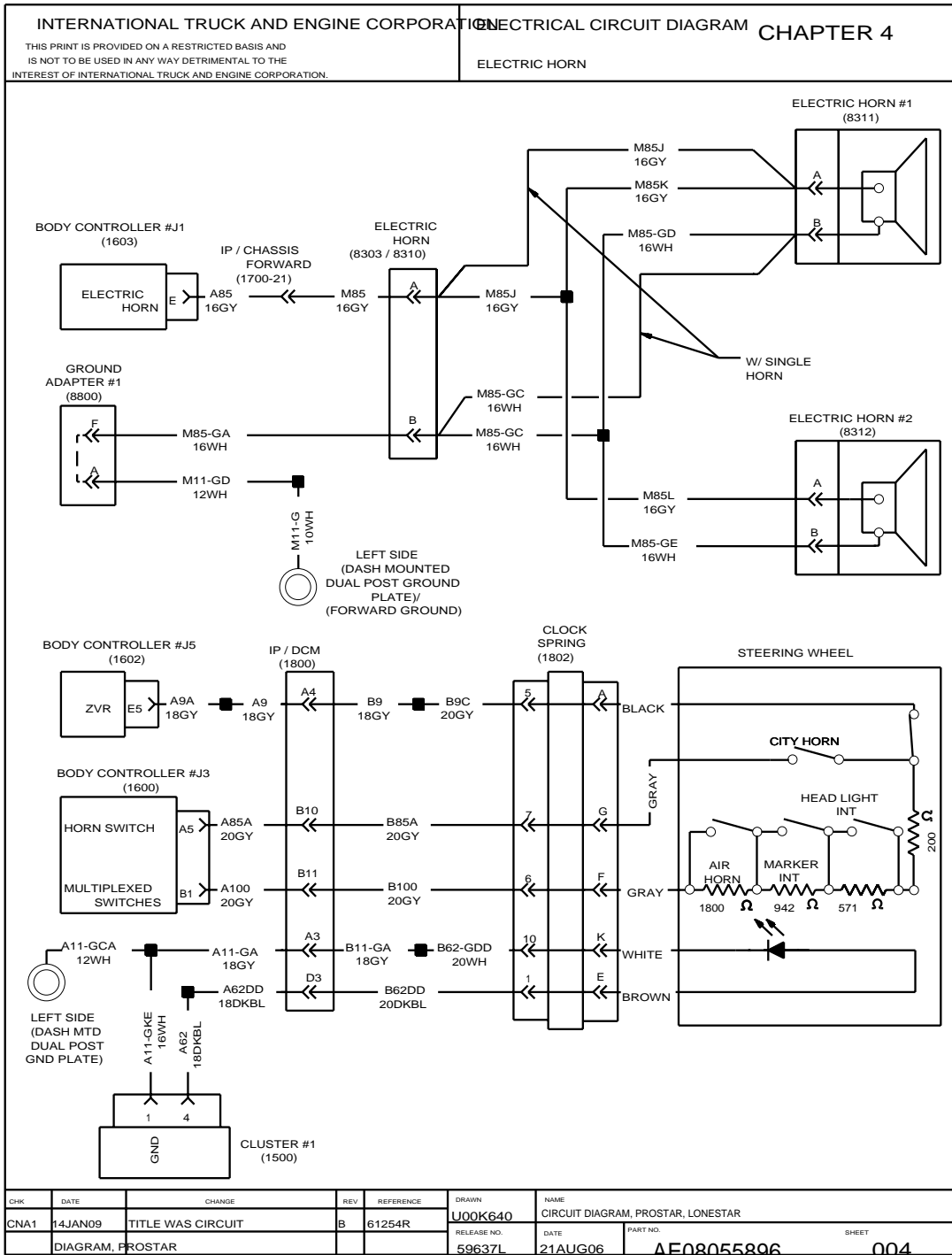


Figure 54 Electric Horn

4.5. MIRRORS HEATED AND LIGHTED, P. 5

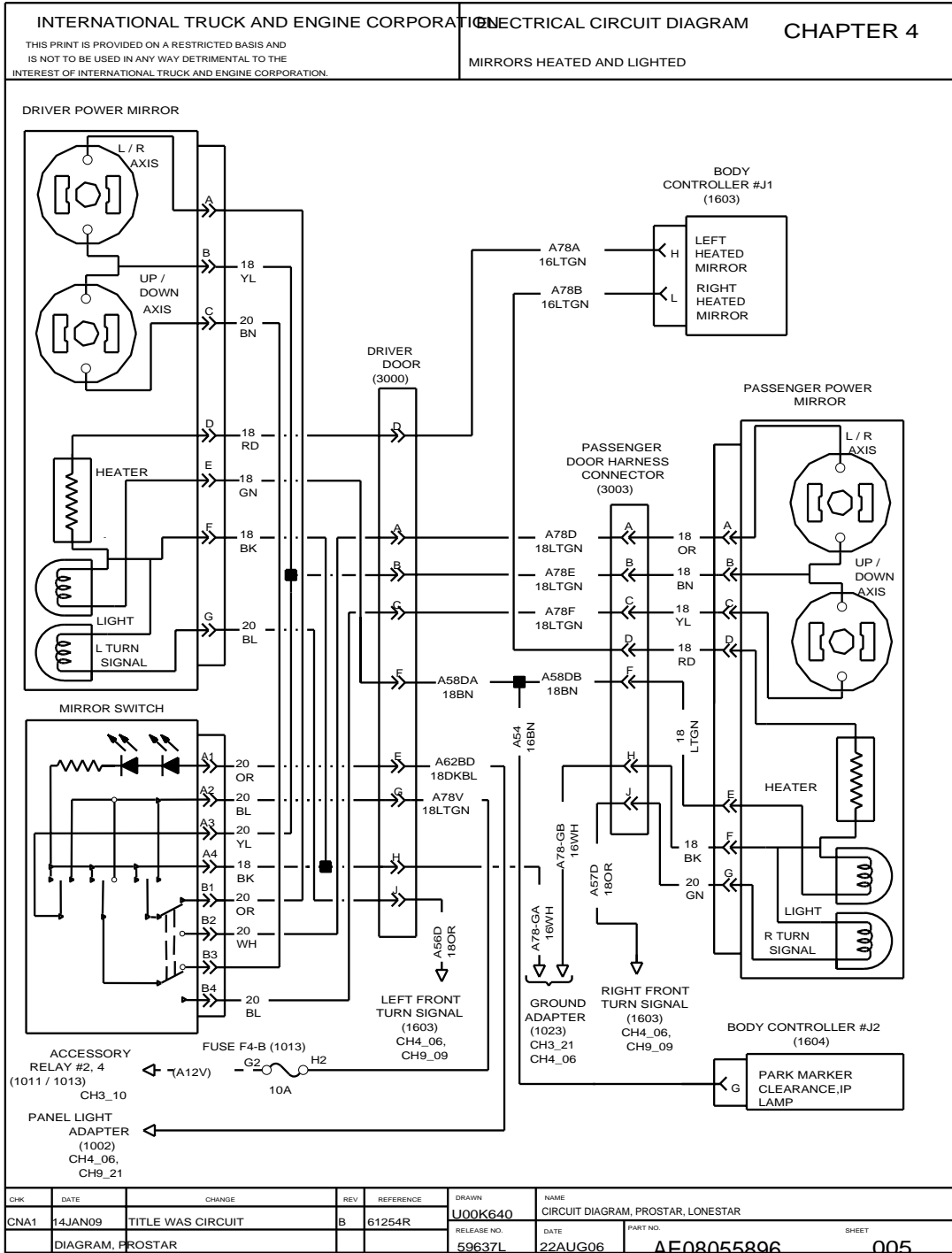


Figure 55 Mirrors Heated and Lighted

4.6. MIRRORS HEATED AND LIGHTED, P. 6

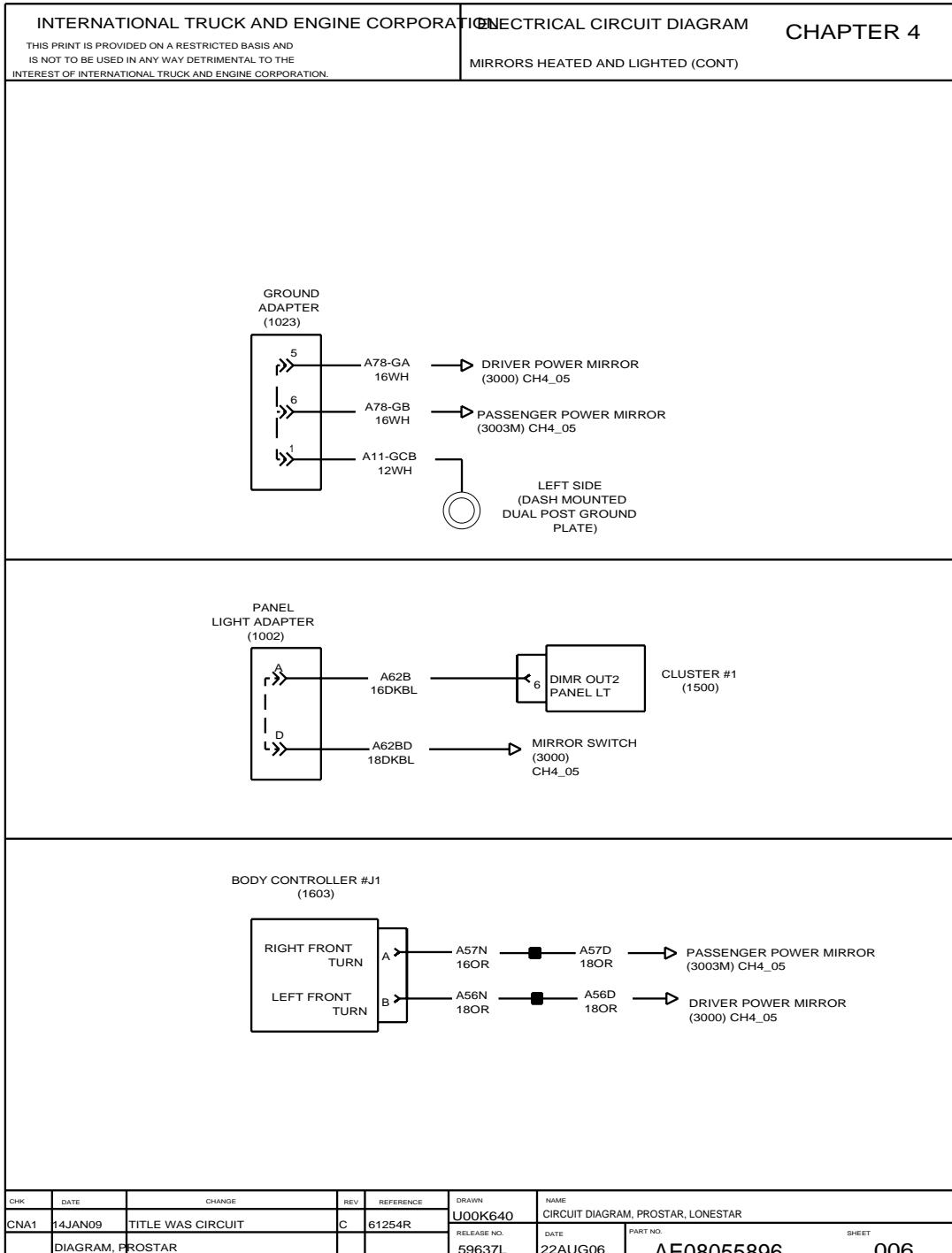


Figure 56 Mirrors Heated and Lighted

4.7. TELEMATICS, P. 7

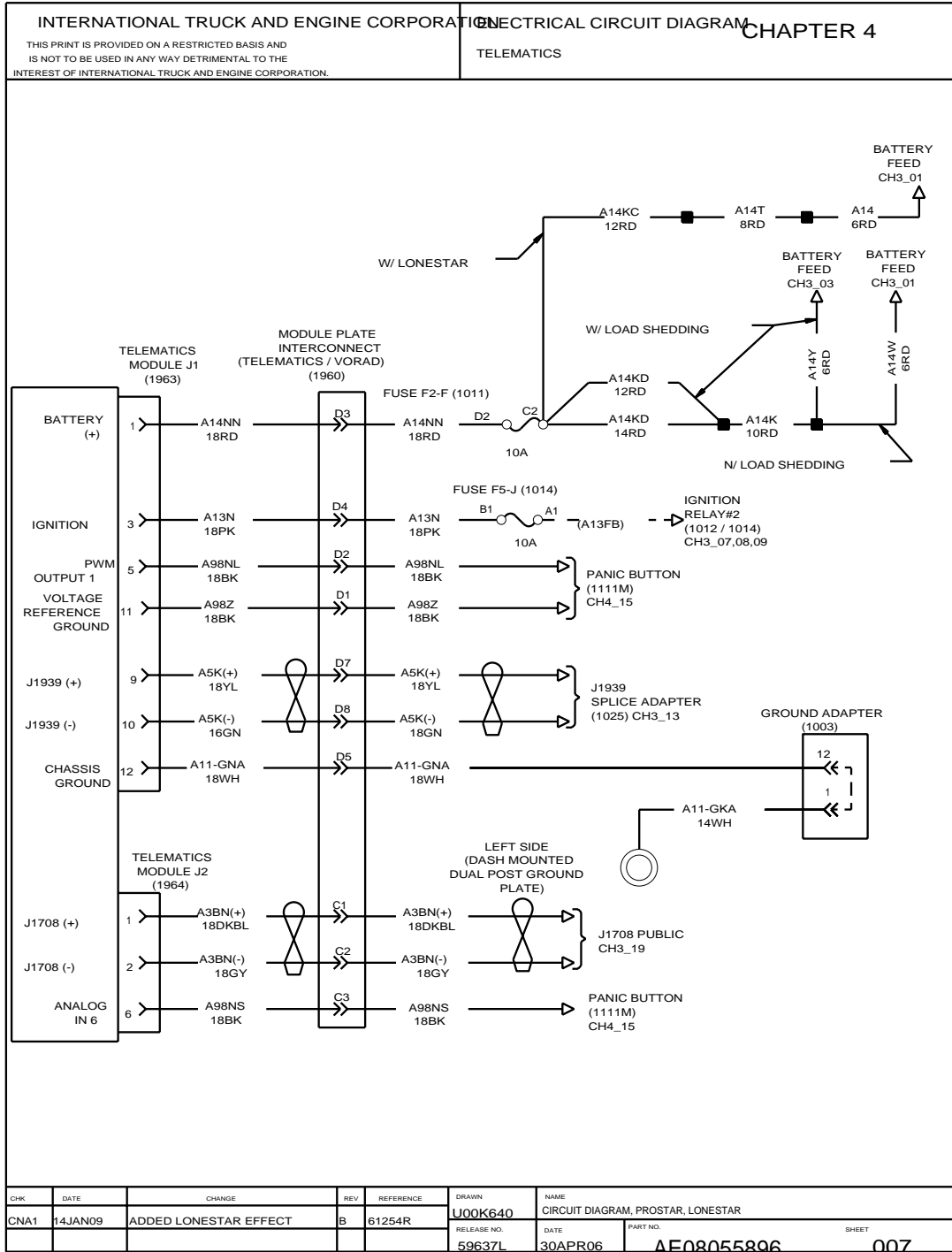


Figure 57 Telematics

4.8. SATELLITE COMMUNICATION SYSTEM — QUALCOMM TMCT DAYCAB, P. 8

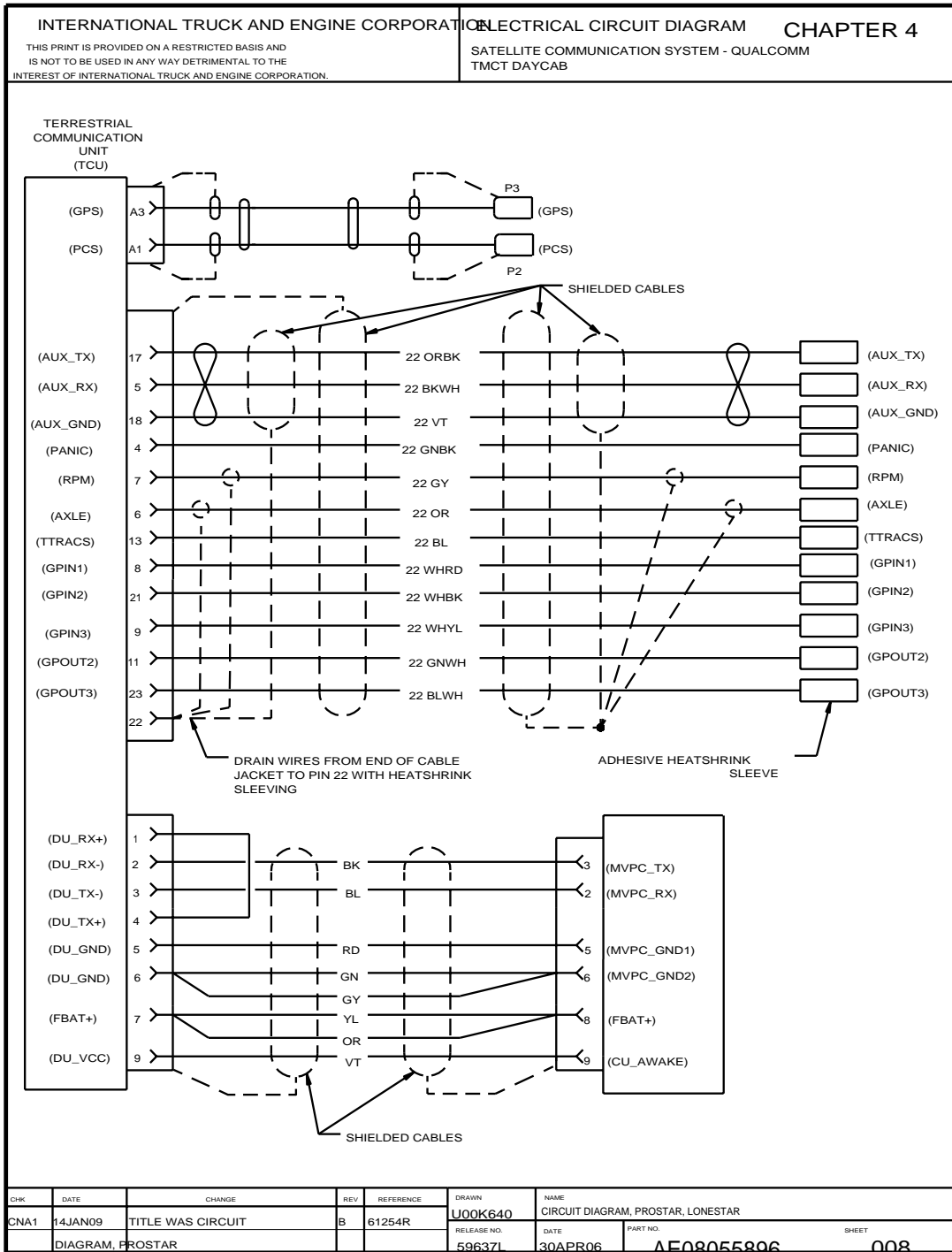


Figure 58 Satellite Communication System — Qualcomm TMCT Daycab

4.9. SATELLITE COMMUNICATION SYSTEM — QUALCOMM TMCT DAYCAB, P. 9

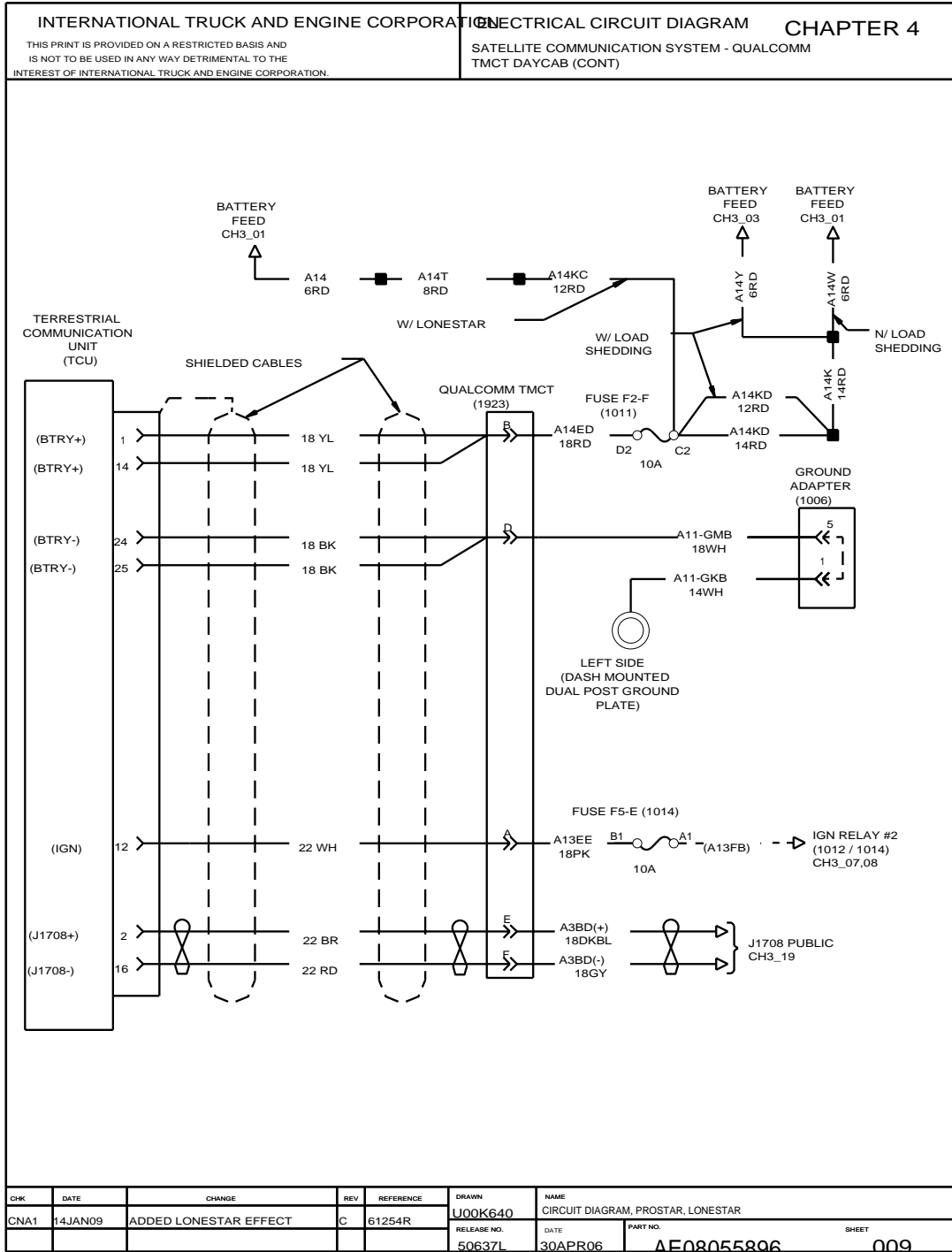


Figure 59 Satellite Communication System — Qualcomm TMCT Daycab

4.10. SATELLITE COMMUNICATION SYSTEM — QUALCOMM TMCT SLEEPER, P. 10

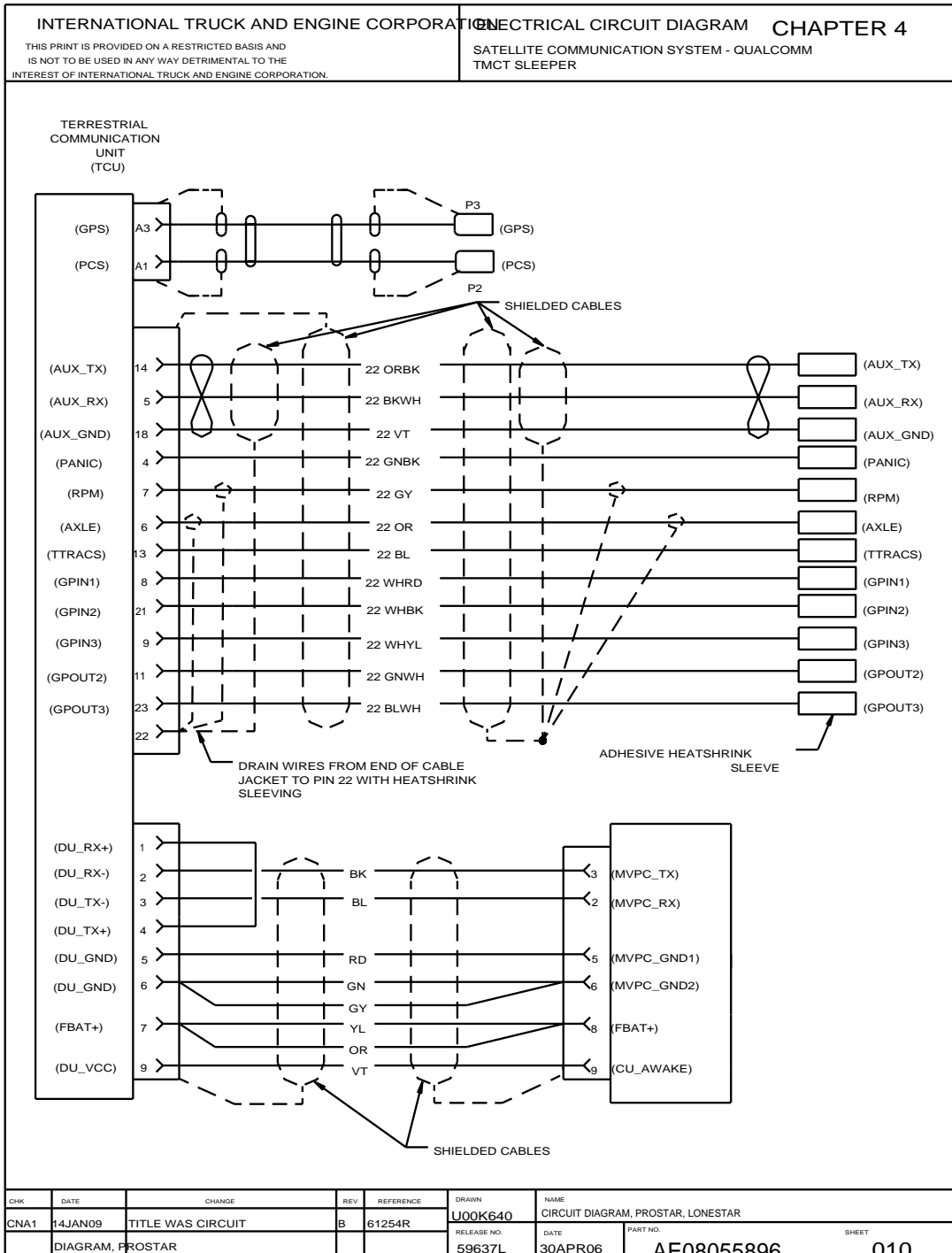


Figure 60 Satellite Communication System — Qualcomm TMCT Sleeper

4.11. SATELLITE COMMUNICATION SYSTEM — QUALCOMM TMCT SLEEPER, P. 11

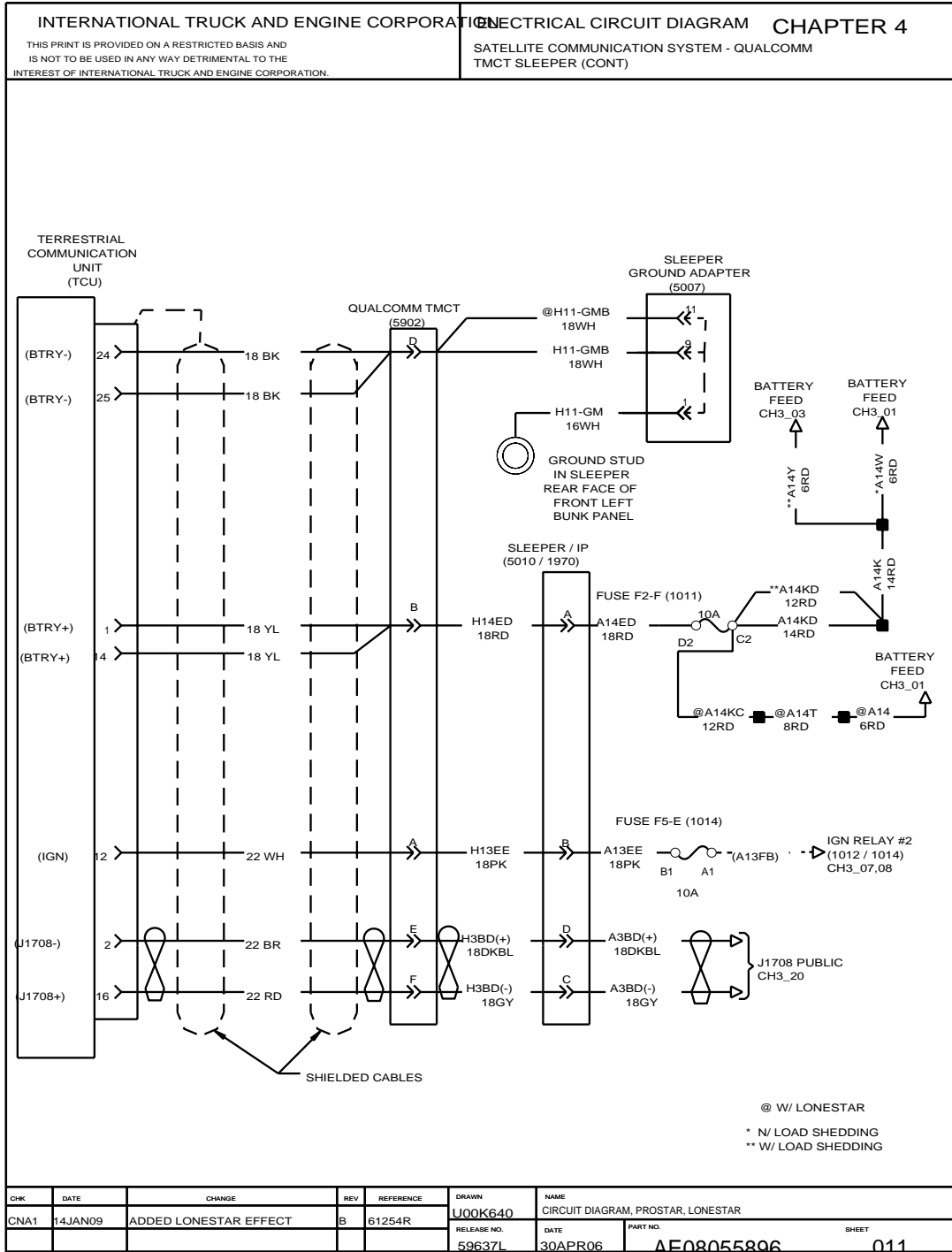


Figure 61 Satellite Communication System — Qualcomm TMCT Sleeper

4.12. SATELLITE COMMUNICATION SYSTEM — QUALCOMM IMCT, P. 12

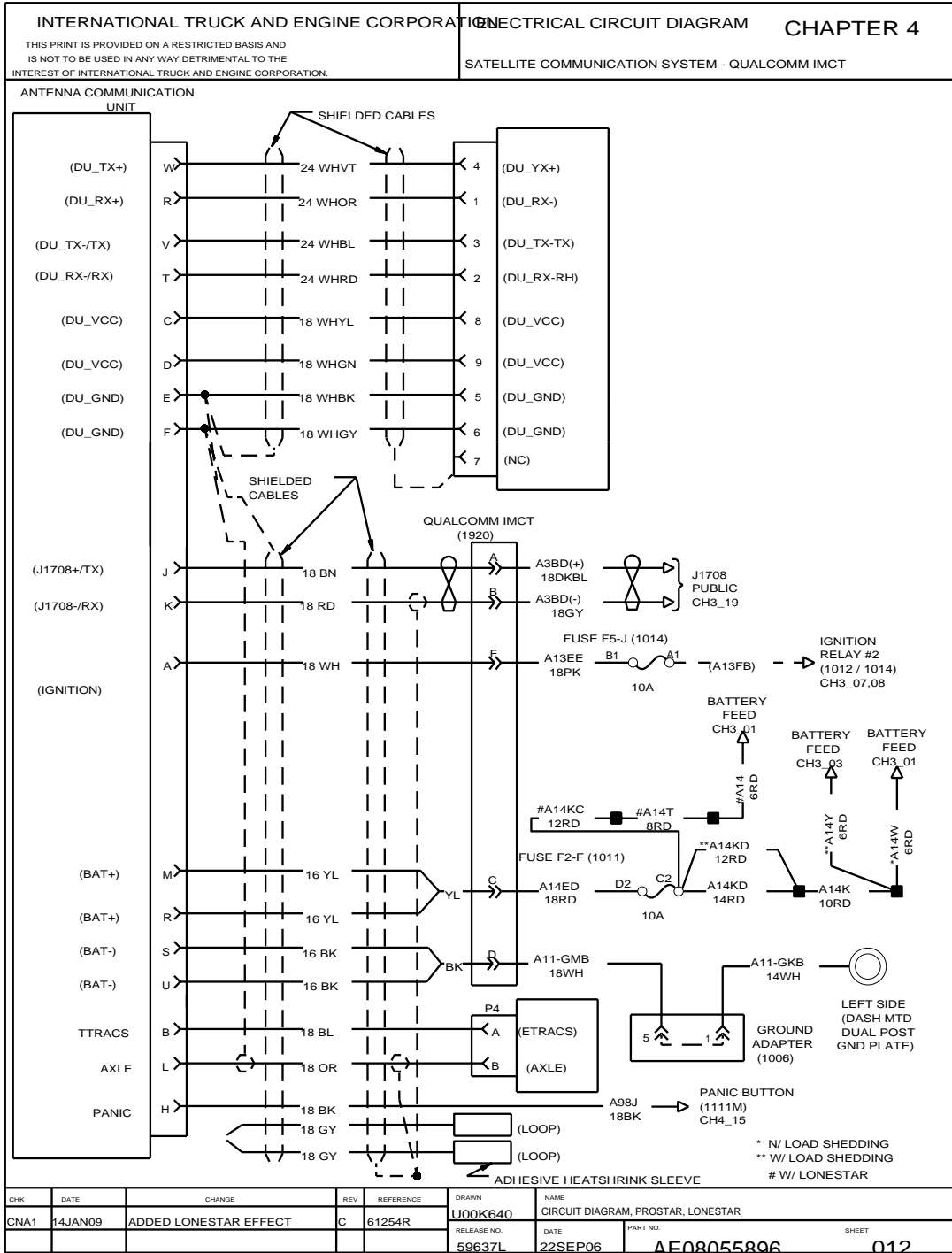


Figure 62 Satellite Communication System — Qualcomm IMCT

4.13. SATELLITE COMMUNICATION SYSTEM — QUALCOMM IMCT, P. 13

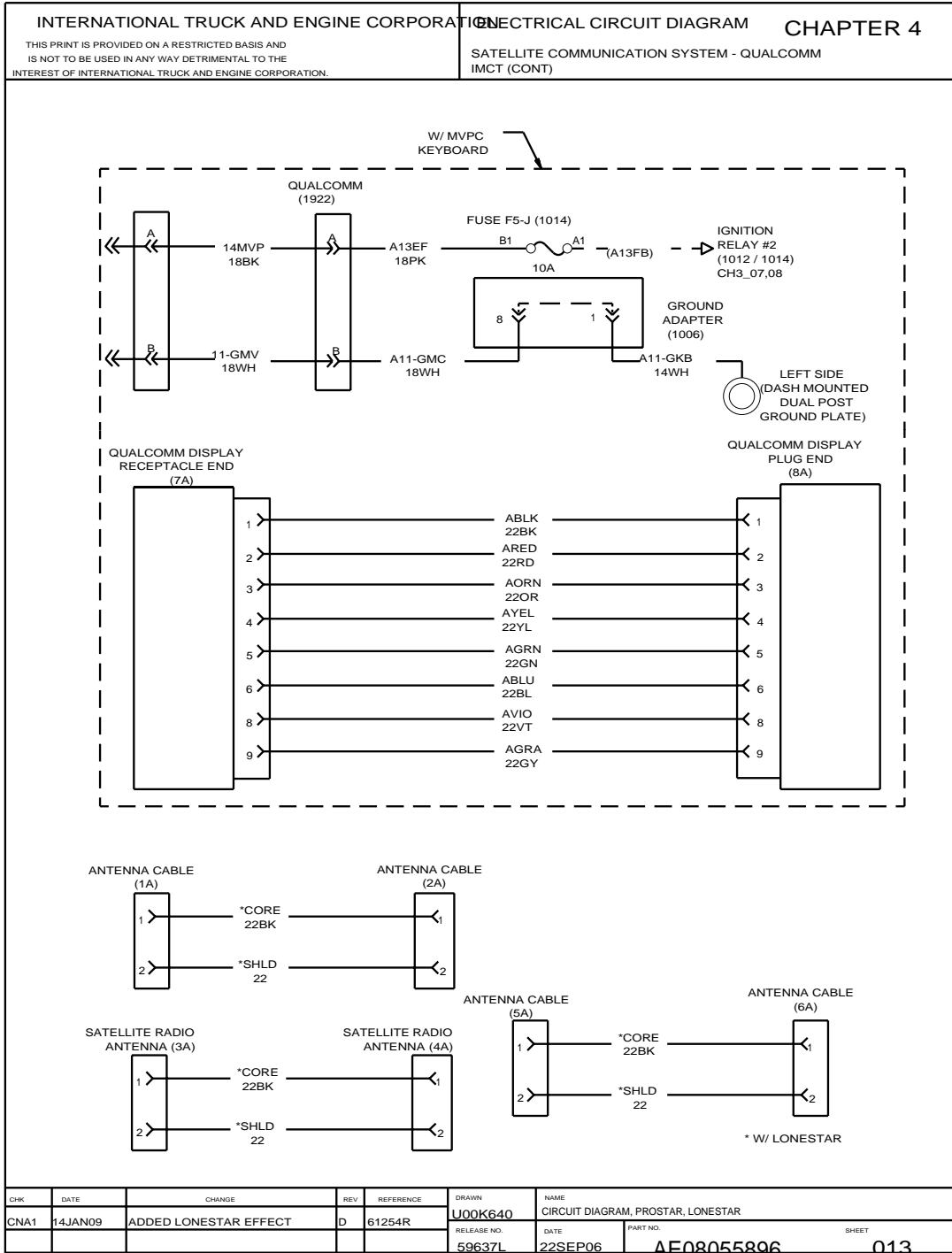


Figure 63 Satellite Communication System — Qualcomm IMCT

4.14. QUALCOMM IMCT — SLEEPER, P. 14

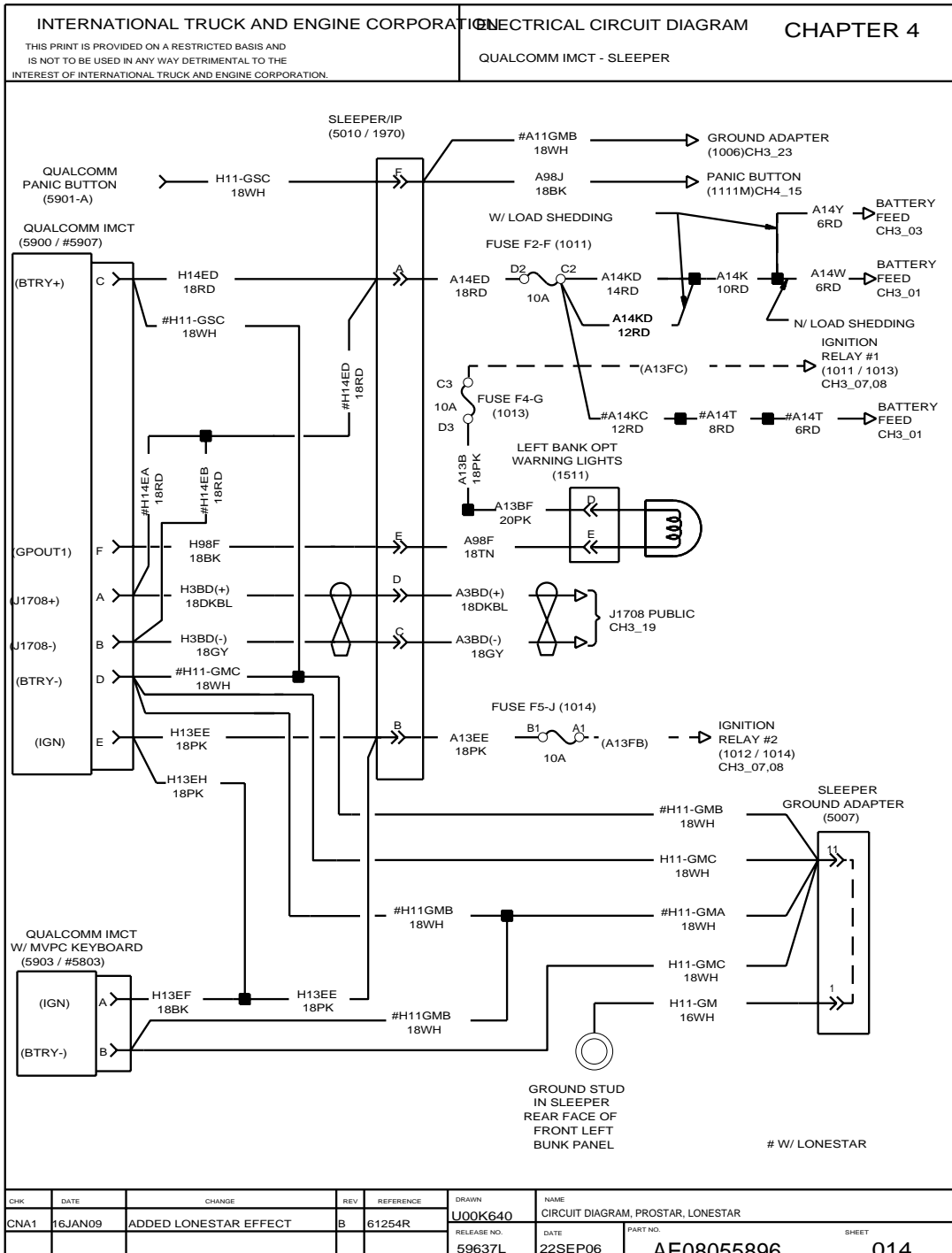


Figure 64 Qualcomm IMCT — Sleeper

4.15. PANIC BUTTON, P. 15

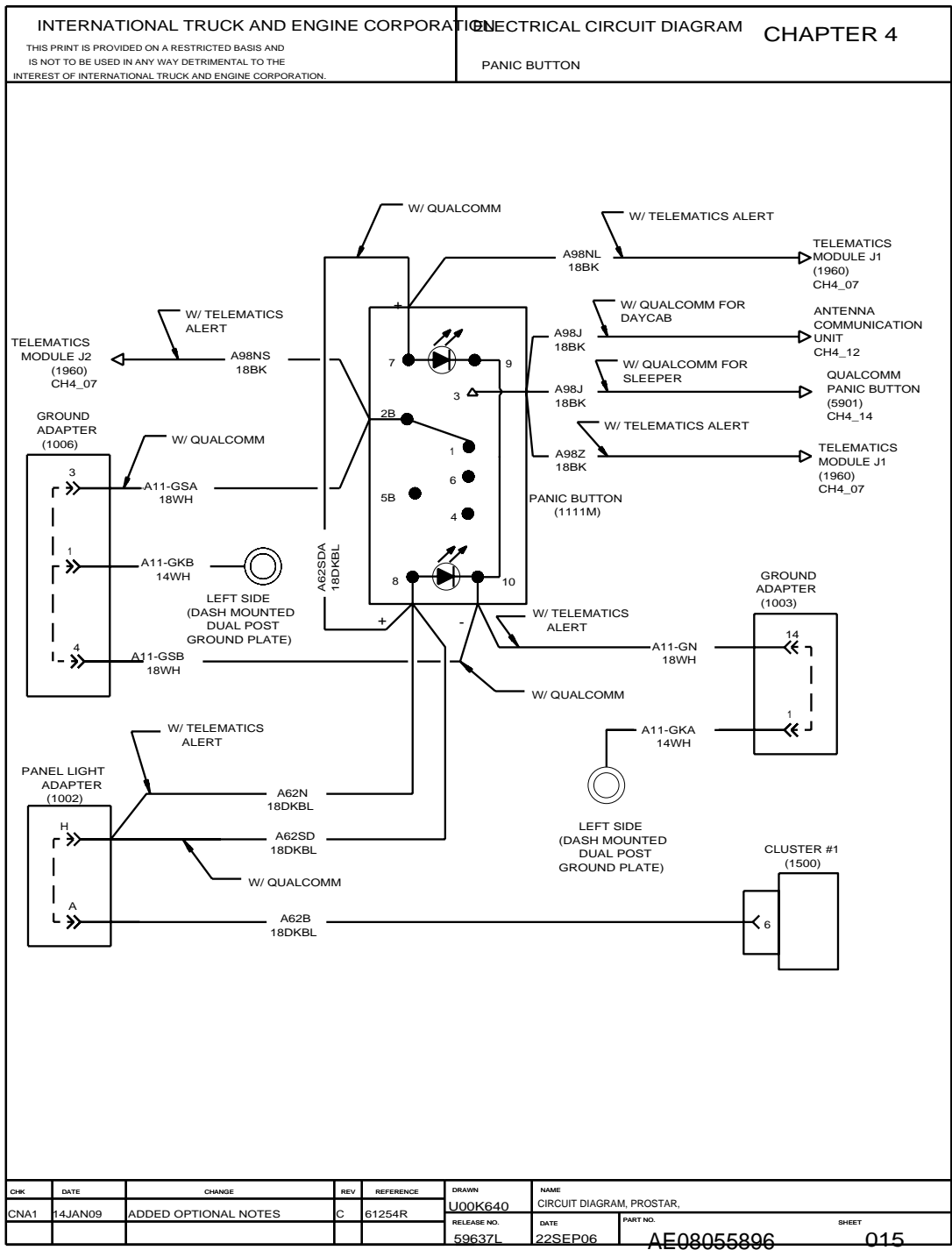


Figure 65 Panic Button

4.16. SATELLITE COMMUNICATION SYSTEM — XATA WITH DAYCAB, P. 16

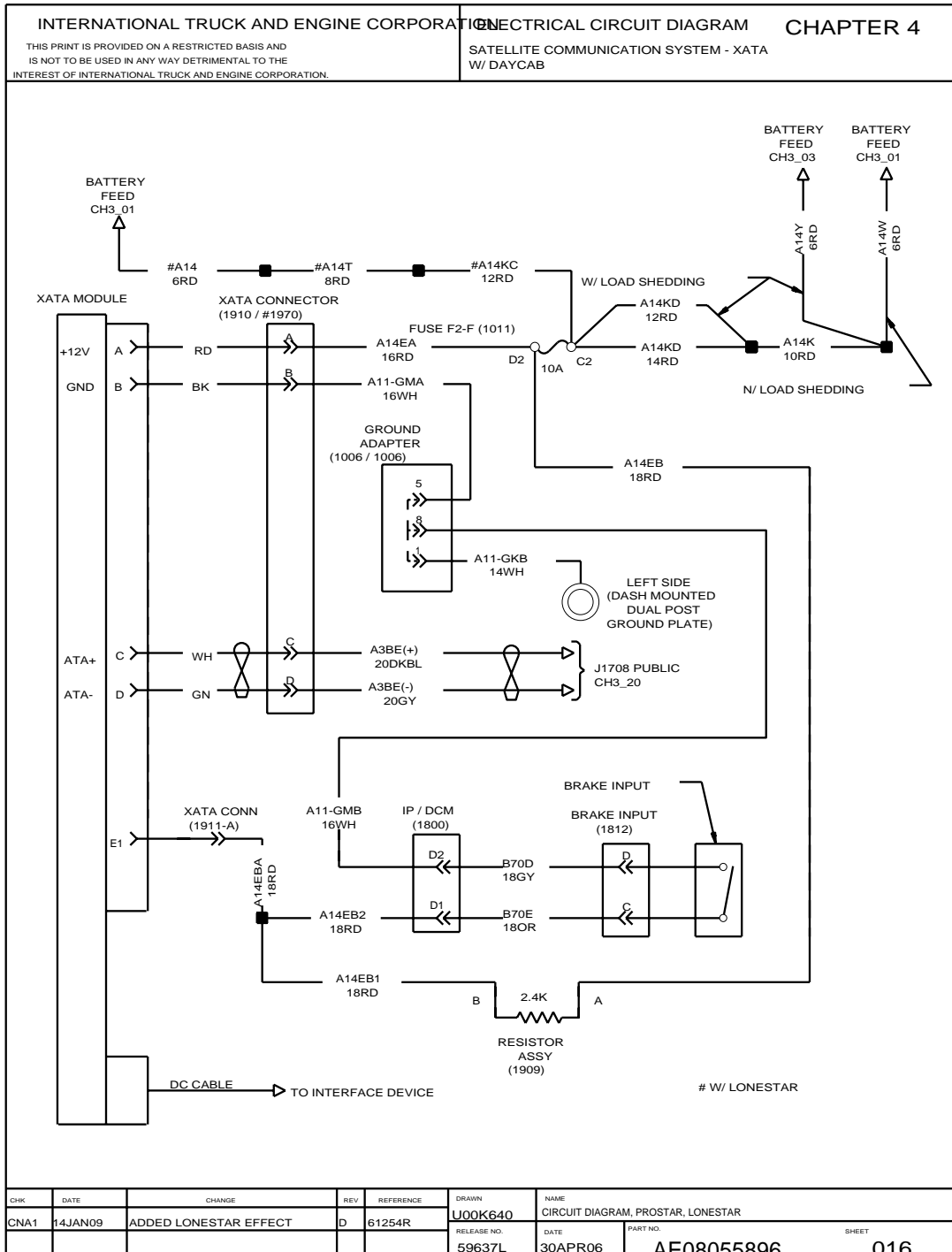


Figure 66 Satellite Communication System — XATA with Daycab

4.17. SATELLITE COMMUNICATION SYSTEM — XATA WITH SLEEPER, P. 17

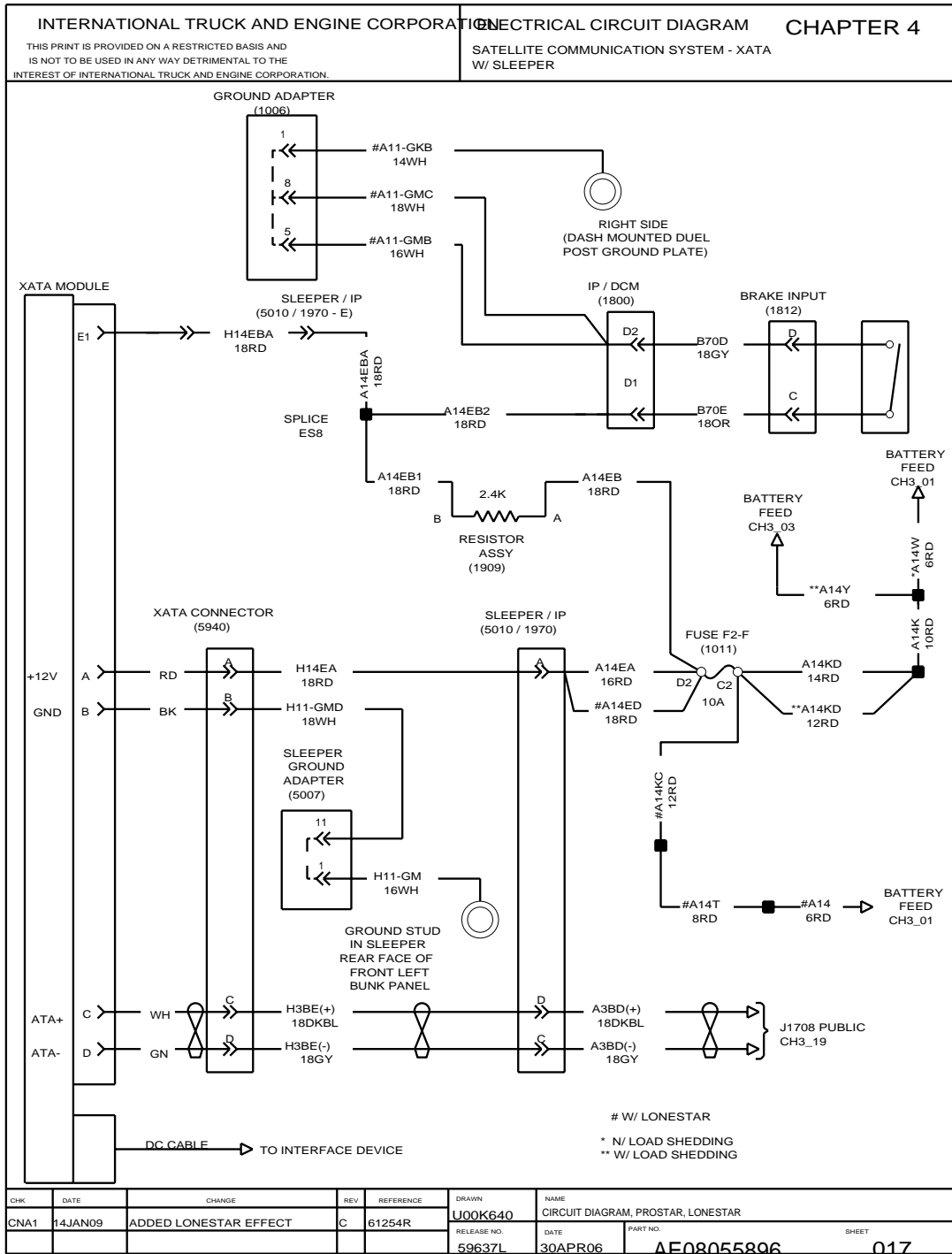


Figure 67 Satellite Communication System — XATA with Sleeper

4.18. RADIO ENTERTAINMENT, SPEAKERS, P. 18

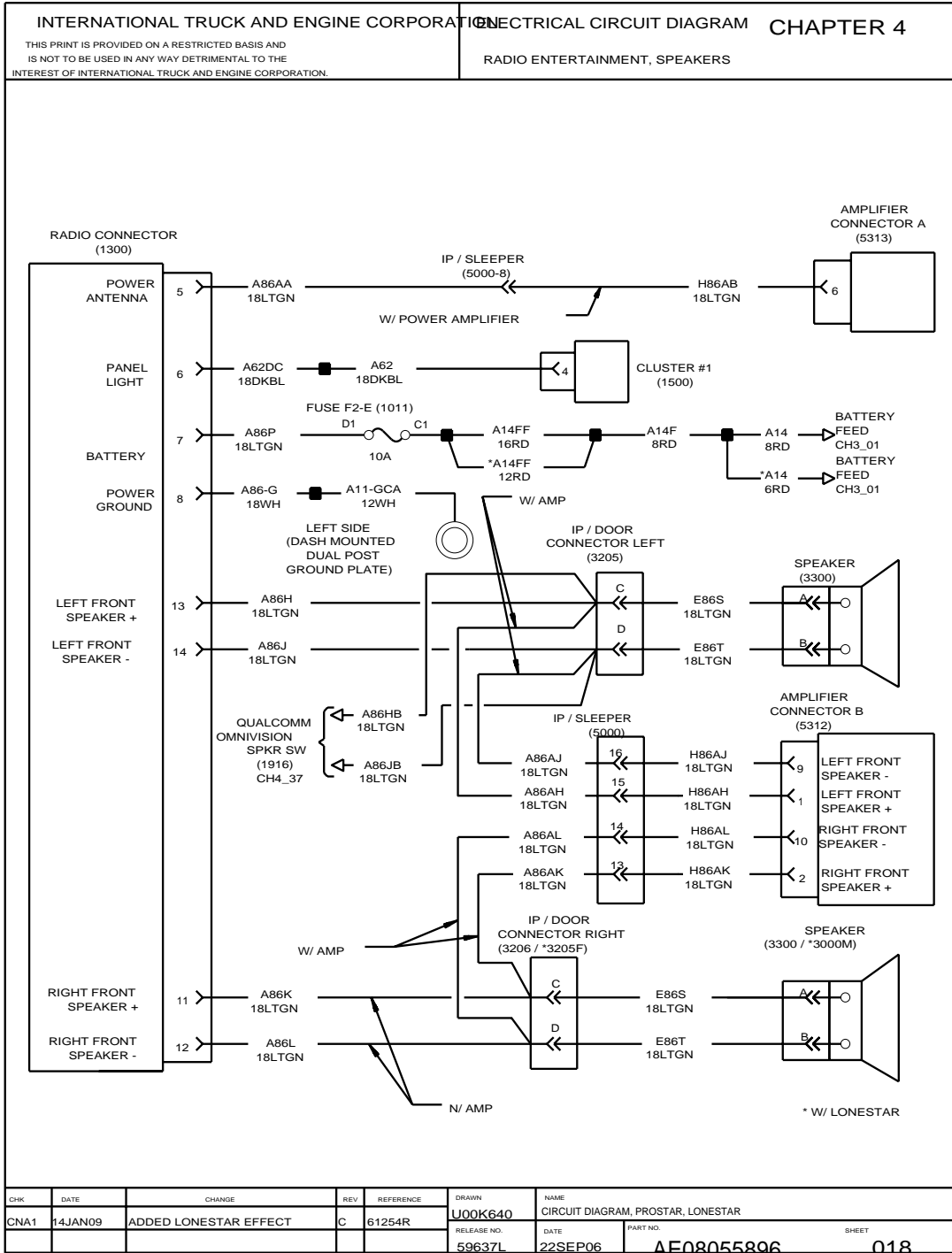


Figure 68 Radio Entertainment, Speakers

4.19. RADIO ENTERTAINMENT, SPEAKERS, P. 18A

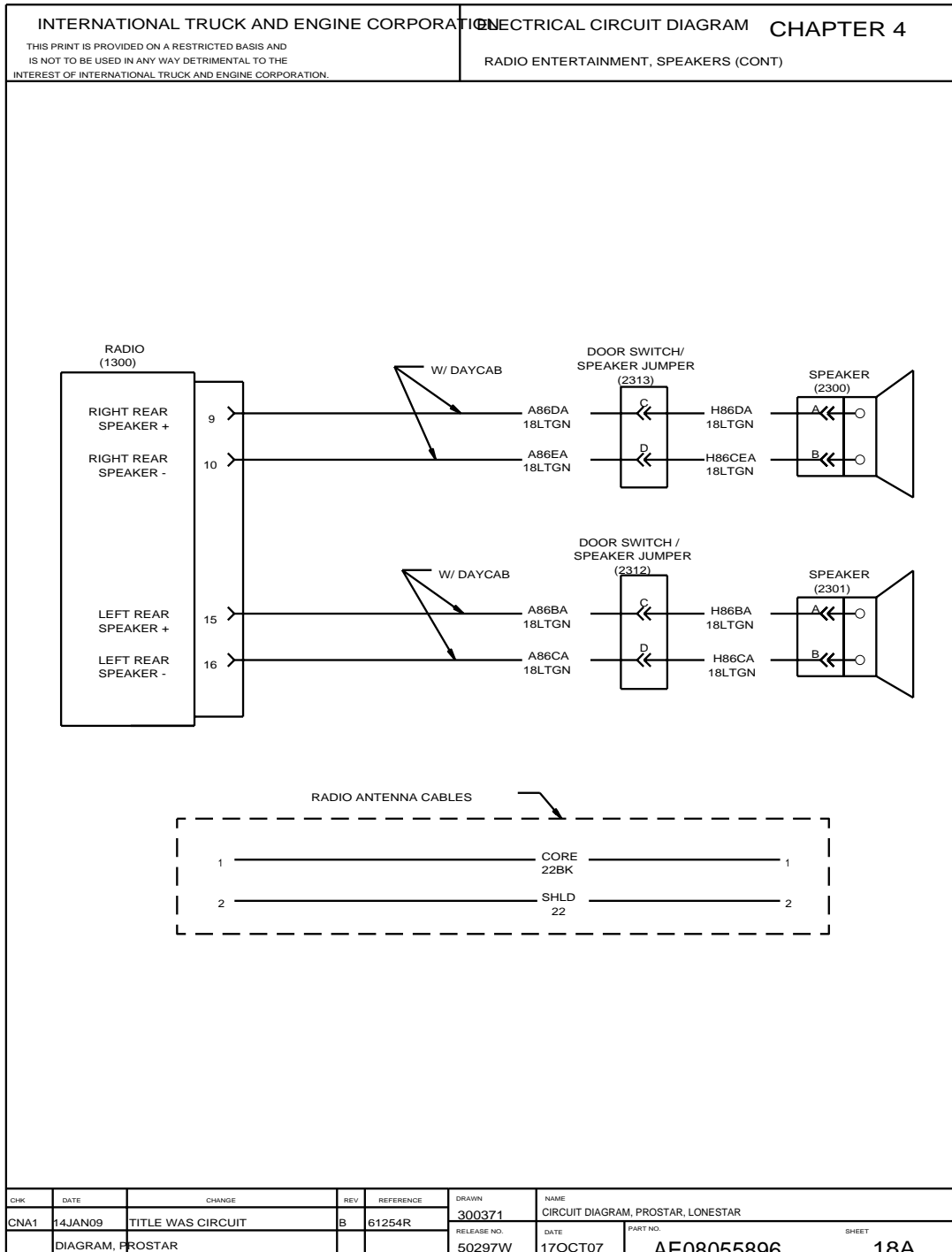


Figure 69 Radio Entertainment, Speakers

4.20. RADIO ENTERTAINMENT, SPEAKERS, P. 19

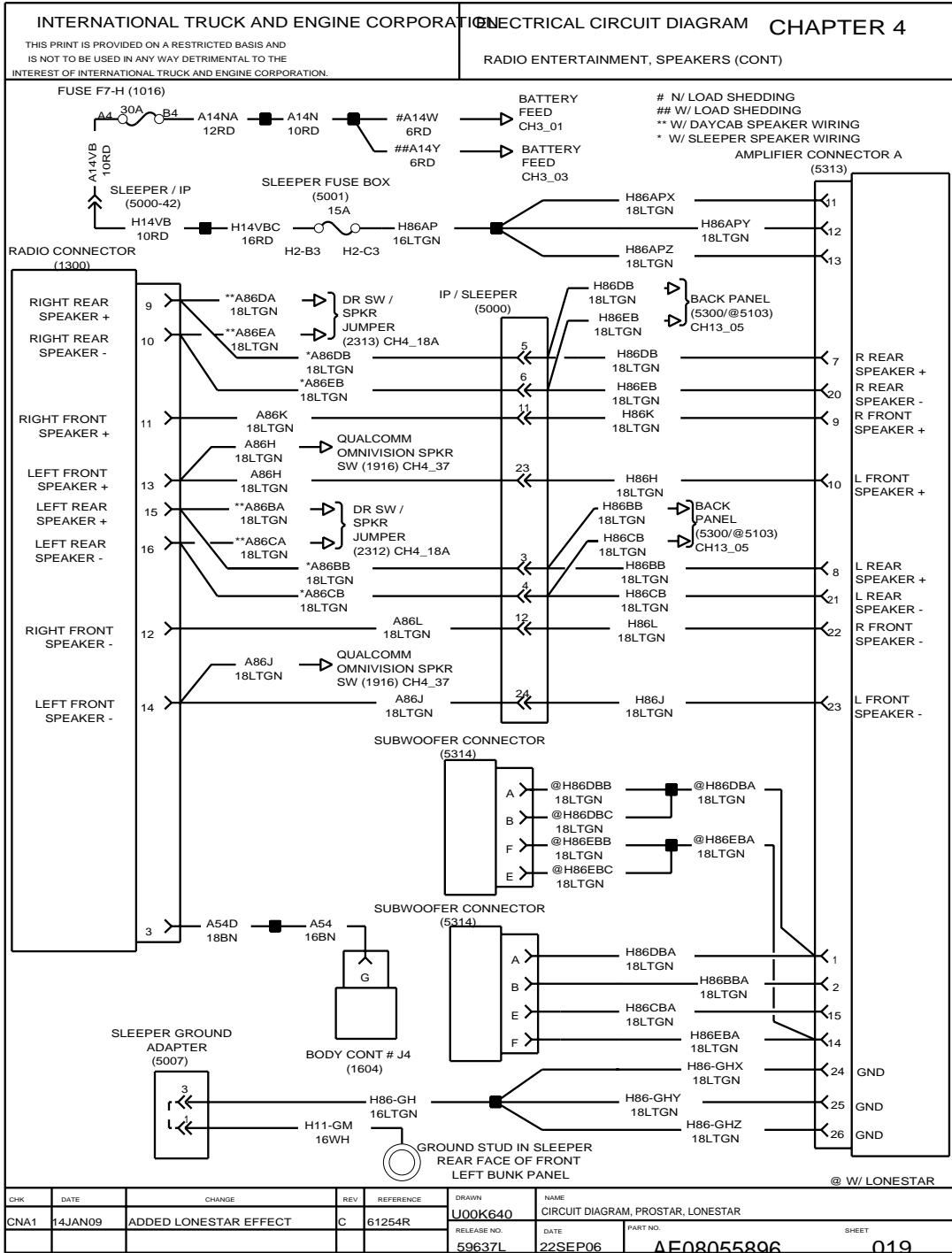


Figure 70 Radio Entertainment, Speakers

4.21. RADIO ENTERTAINMENT, SPEAKERS, P. 19A

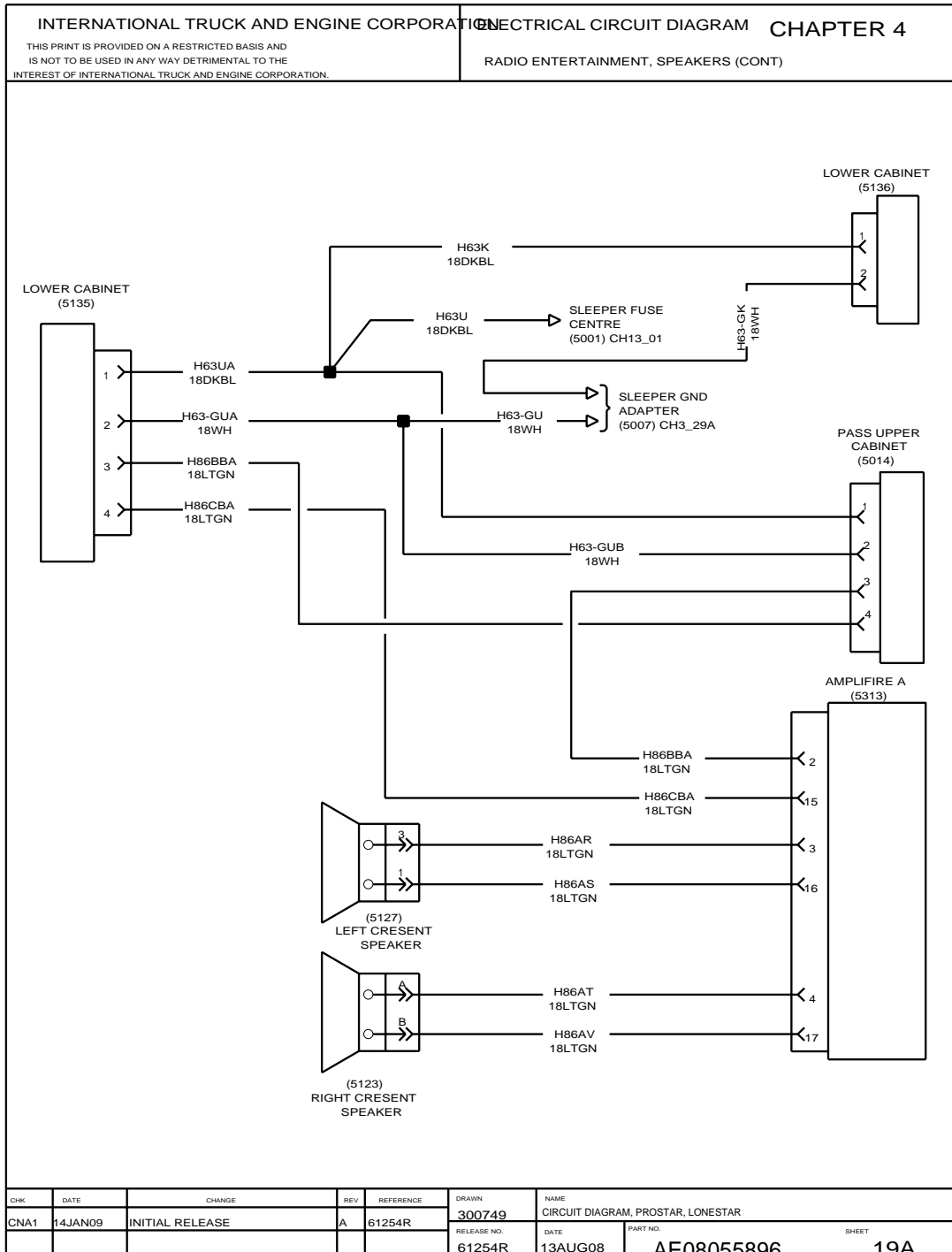


Figure 71 Radio Entertainment, Speakers

4.22. SWITCH PACK, P. 20

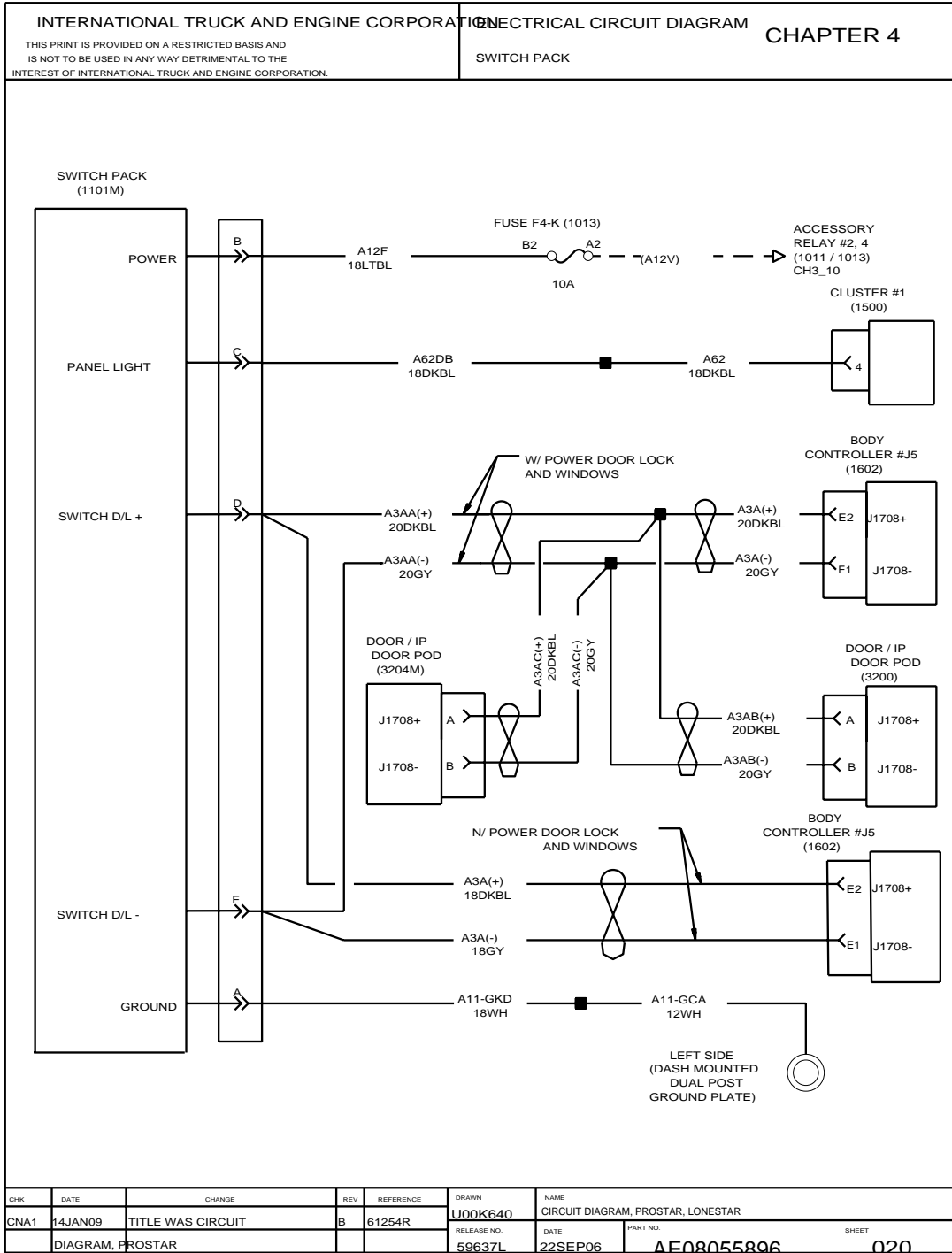


Figure 72 Switch Pack

4.23. WINDSHIELD WIPER MOTOR, P. 21

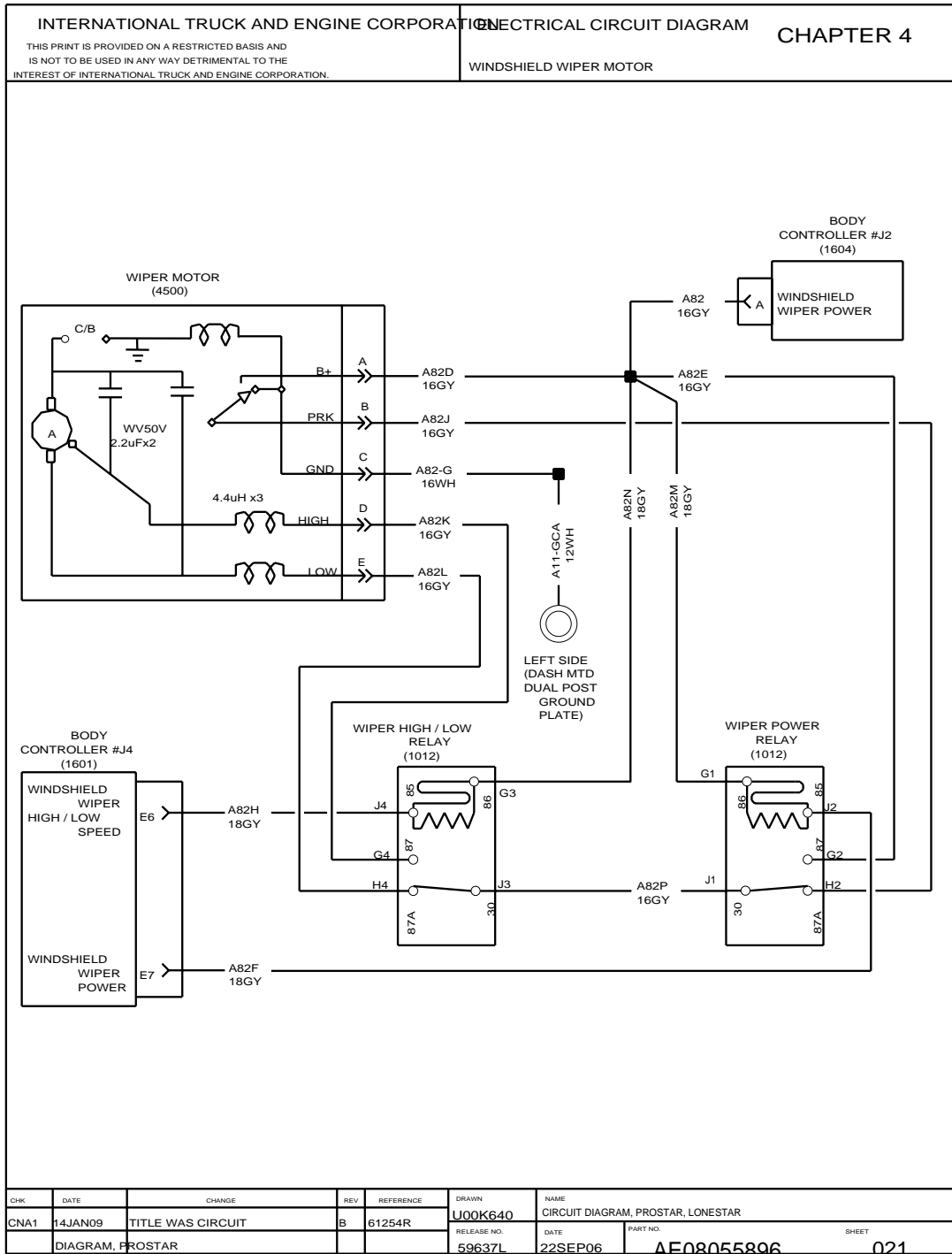


Figure 73 Windshield Wiper Motor

4.24. WINDSHIELD WASHER PUMP, P. 22

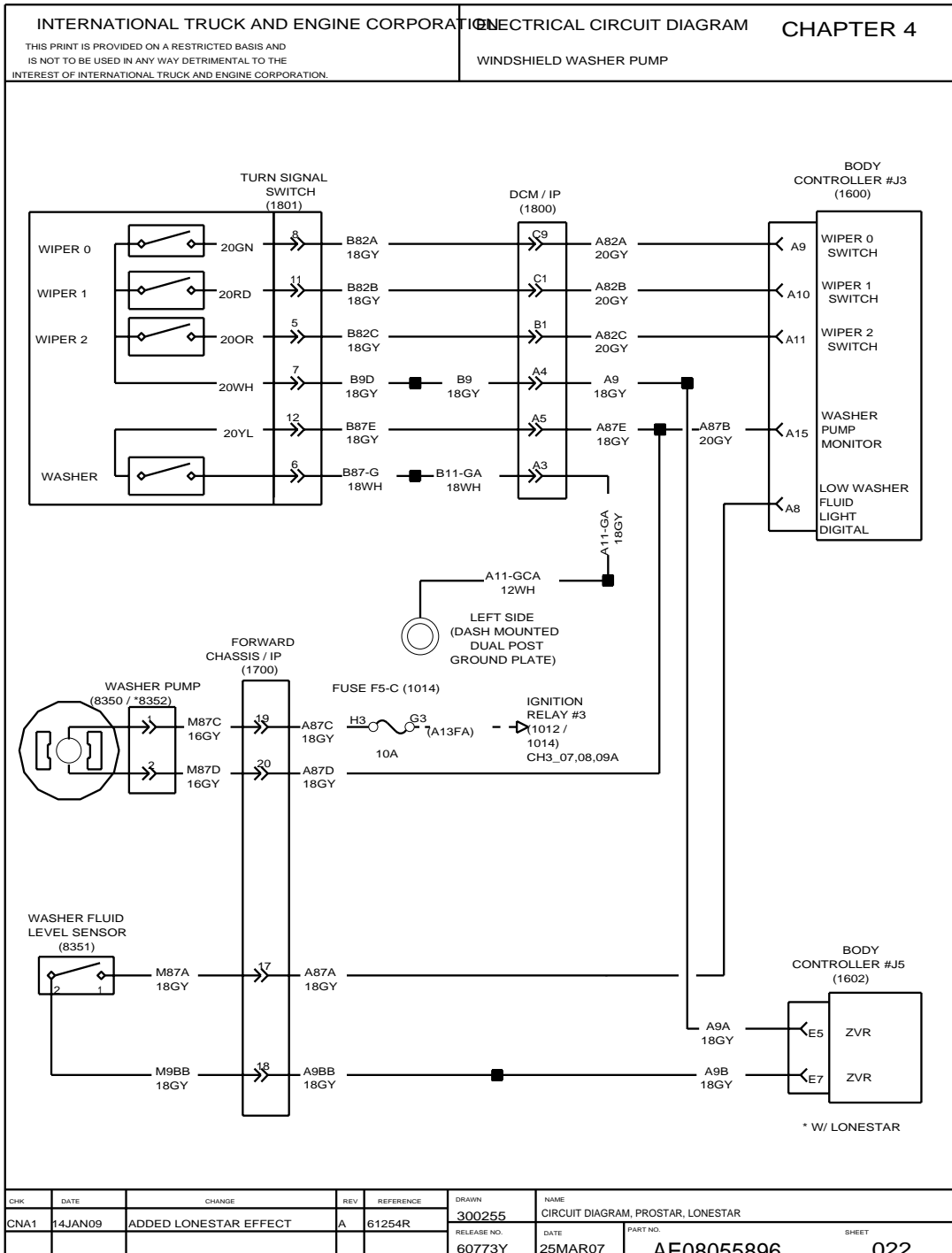


Figure 74 Windshield Washer Pump

4.25. DISPLAY, VEHICLE INFORMATION (VID), P. 23

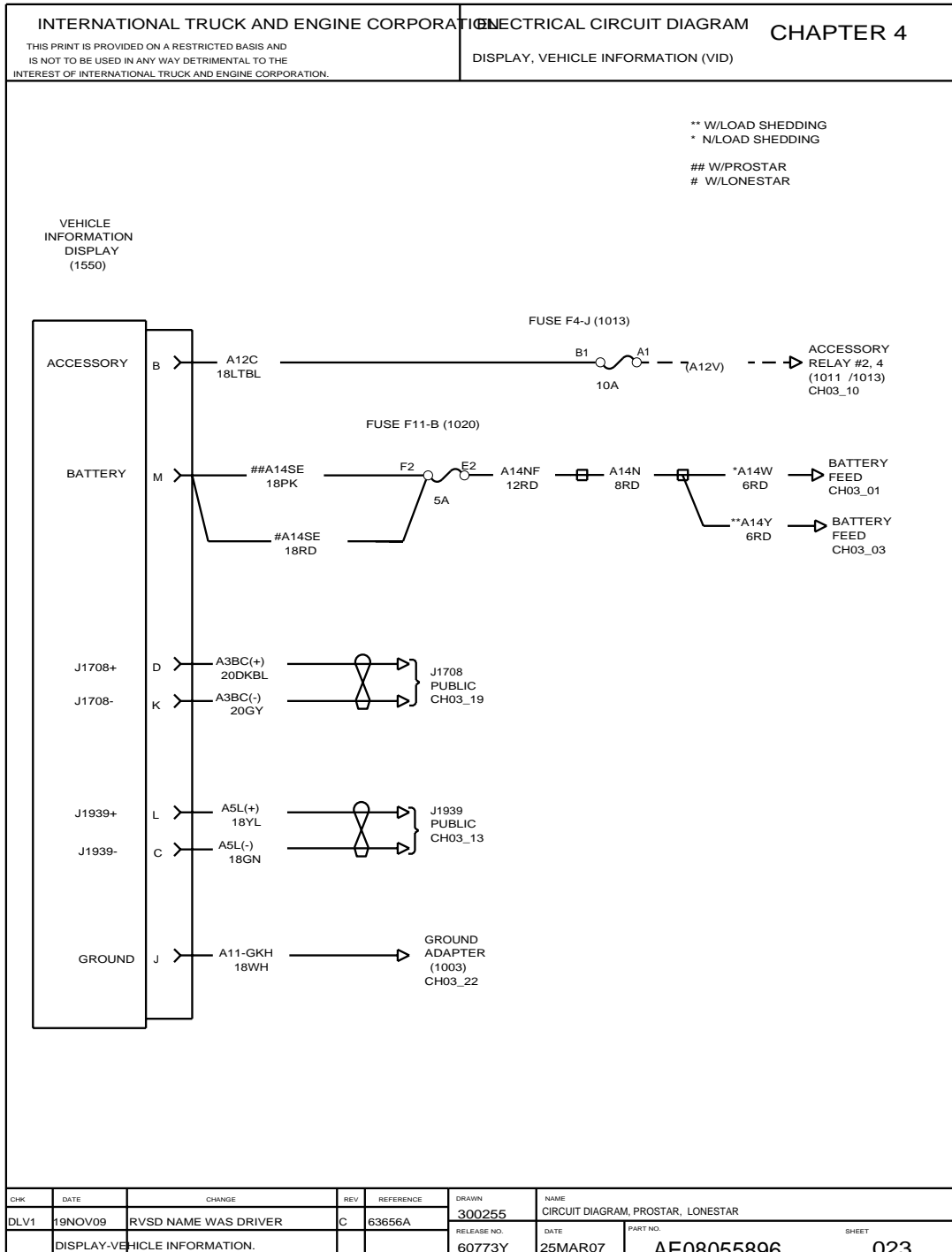


Figure 75 Display, Vehicle Information (VID)

4.26. DISPLAY, DRIVER INTERFACE (DID), P. 23A

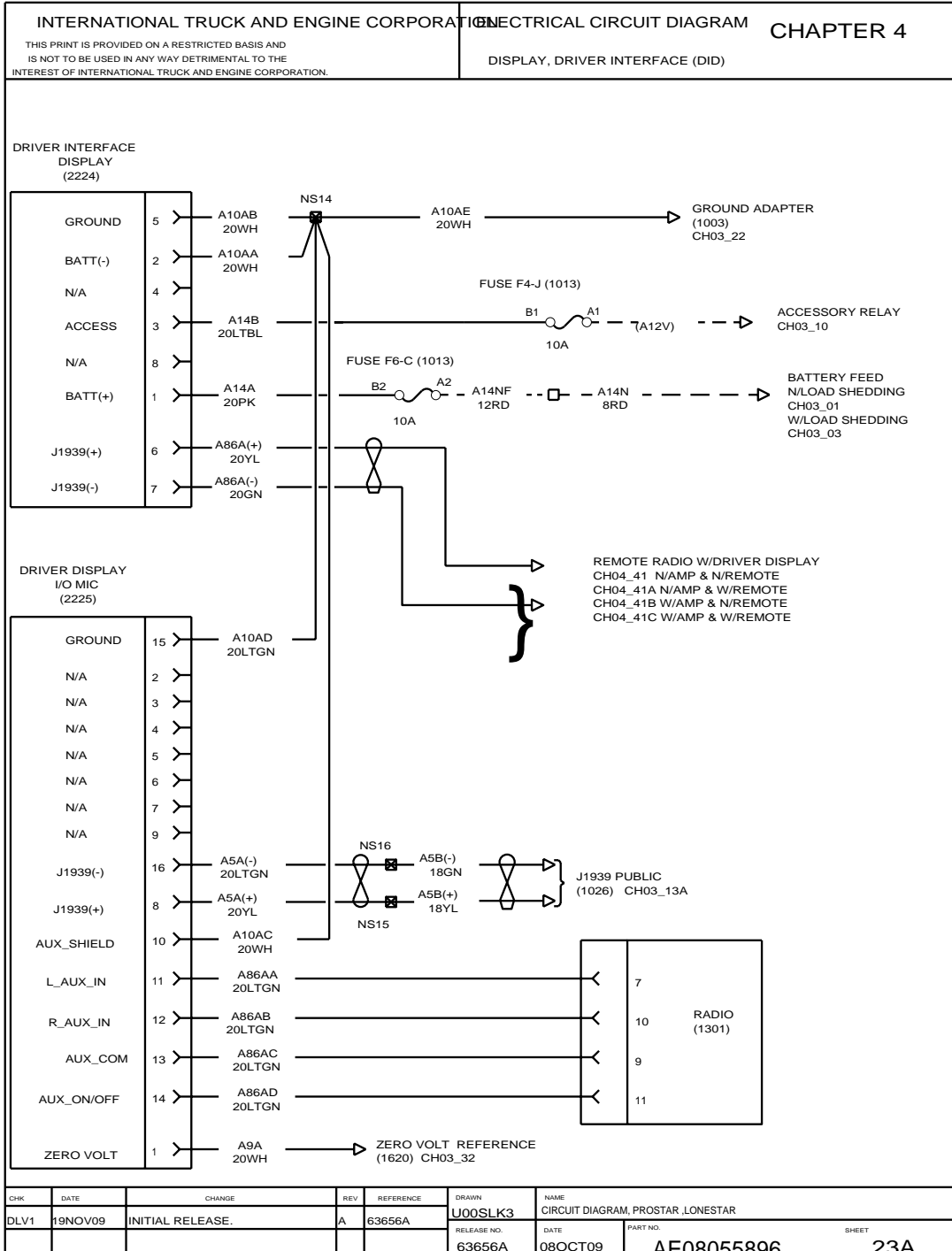


Figure 76 Display, Driver Interface (DID)

4.27. CAT MESSENGER DISPLAY, P. 24

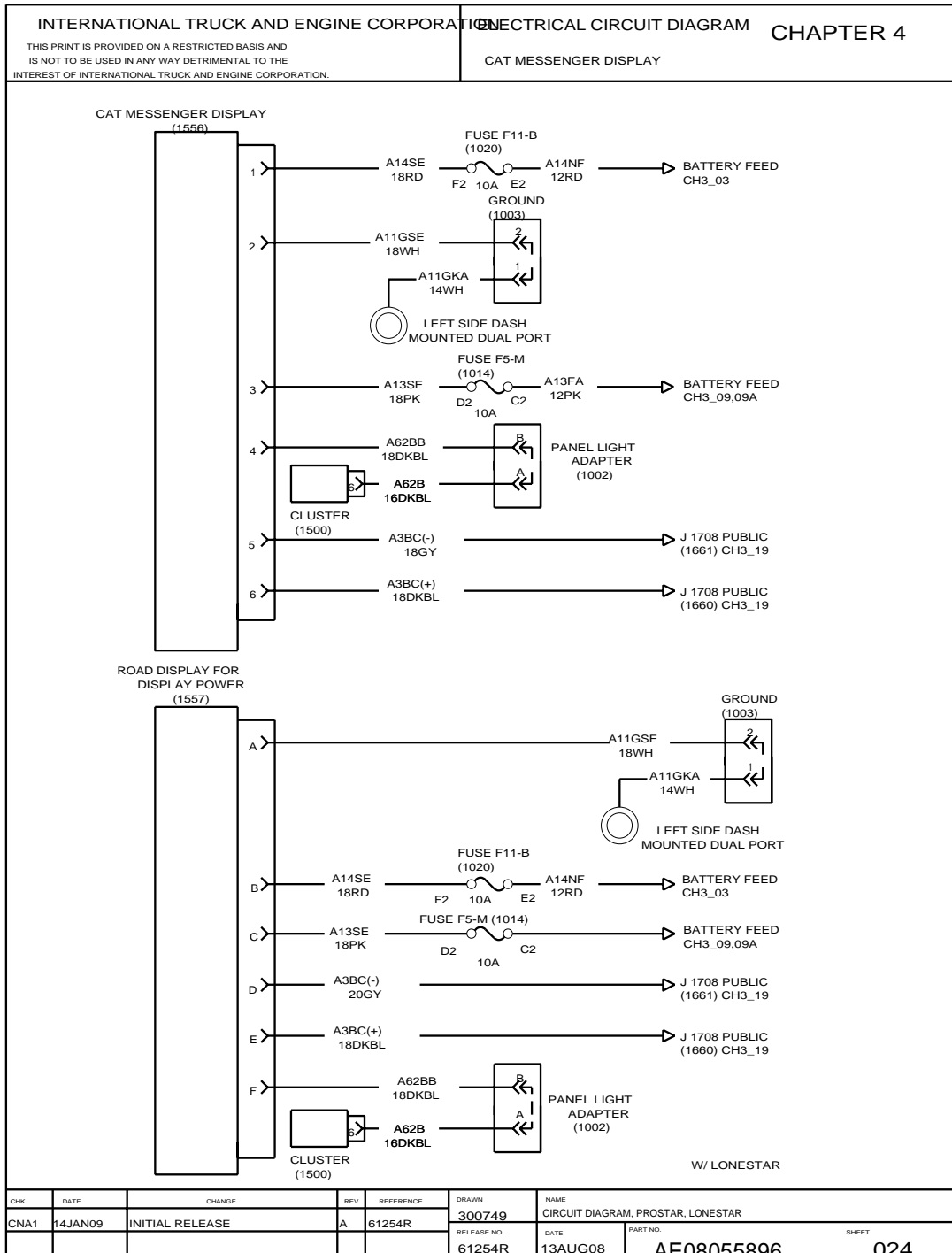


Figure 77 CAT Messenger Display

4.28. BEACON LIGHT SWITCH — FOR DUAL CUSTOMER ACCESSORY, P. 25

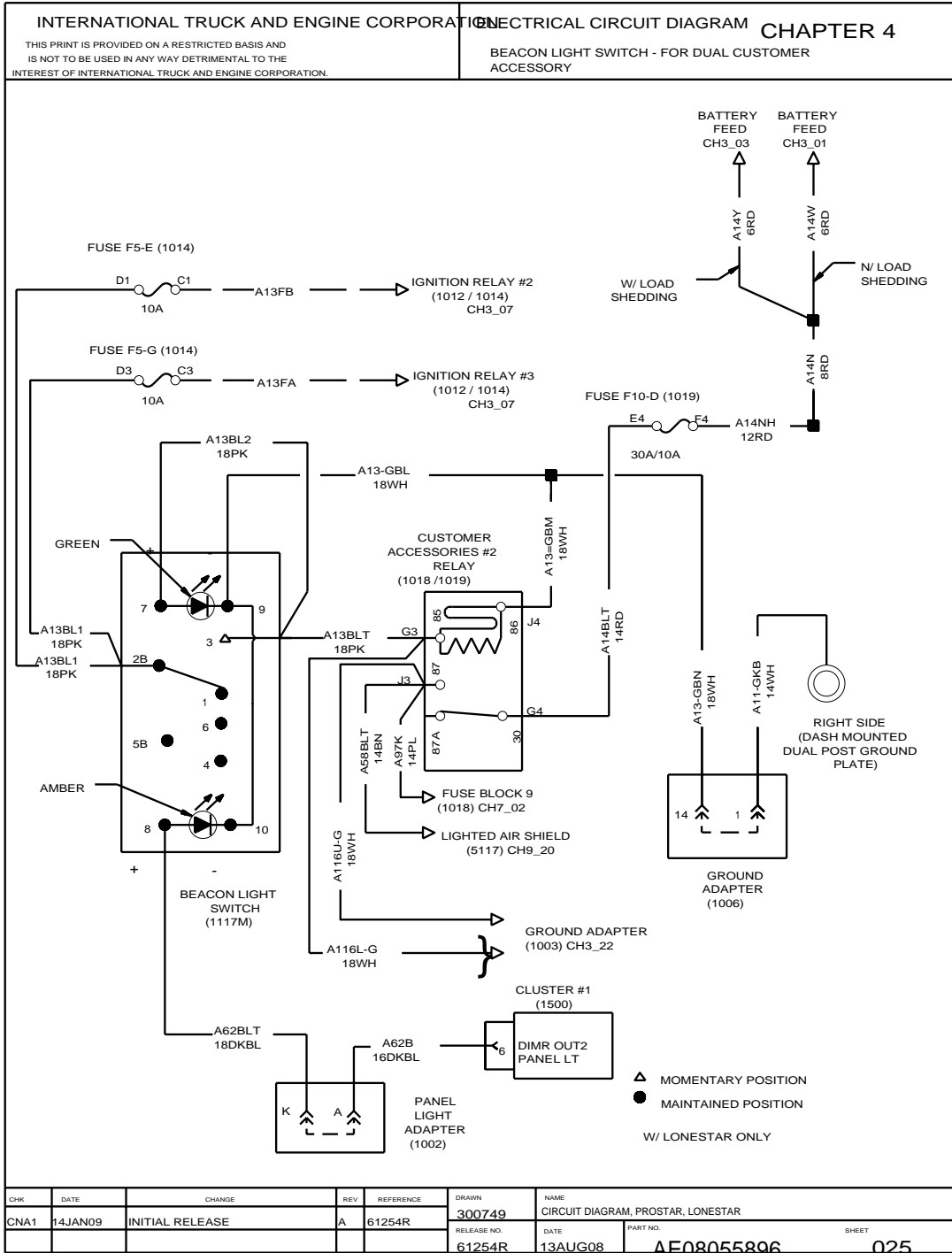


Figure 78 Beacon Light Switch — for Dual Customer Accessory

4.29. DOOR SWITCHES — DOME LAMP, P. 26

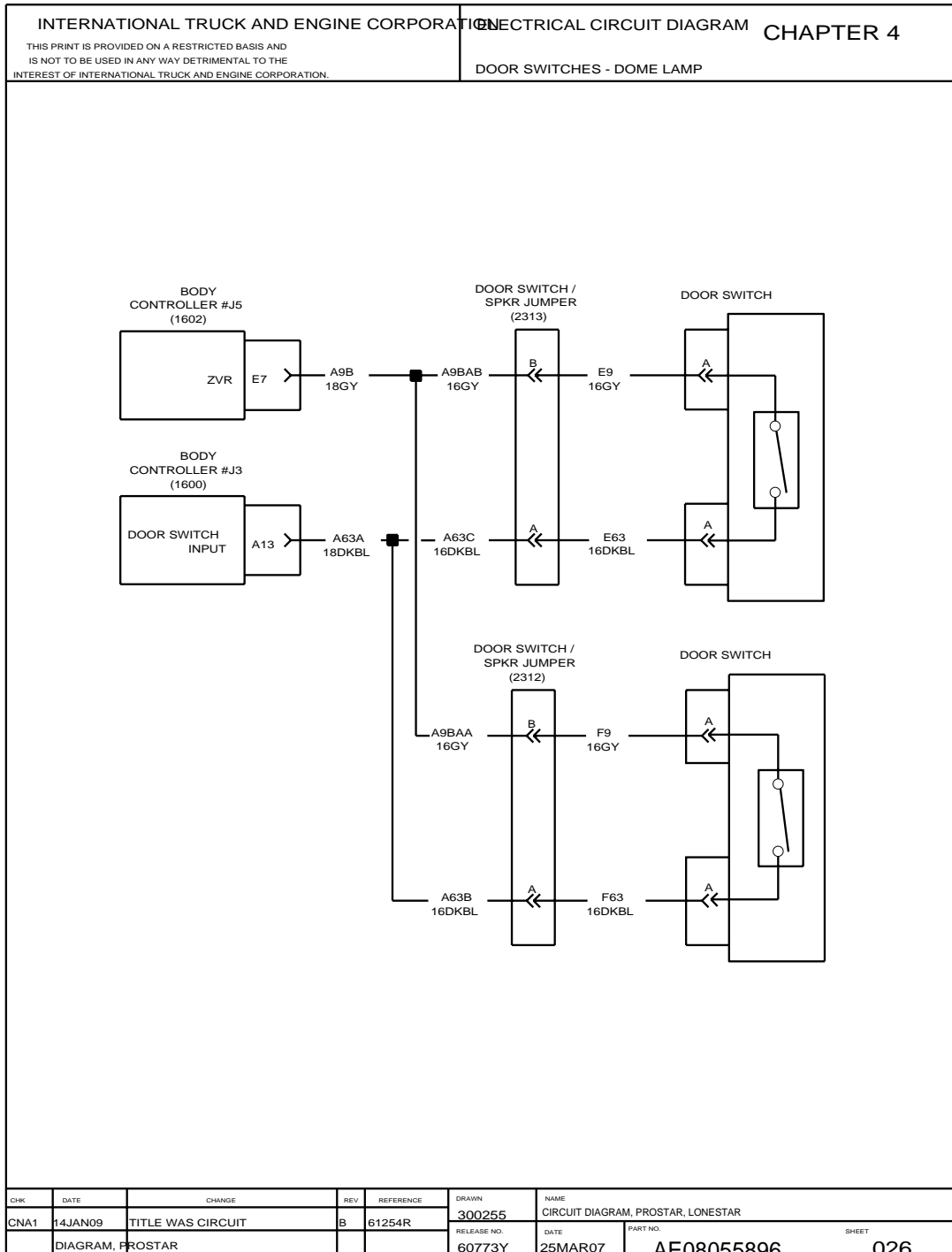


Figure 79 Door Switches — Dome Lamp

4.30. SPARE SWITCH — FOR SINGLE CUSTOMER ACCESSORY, P. 27

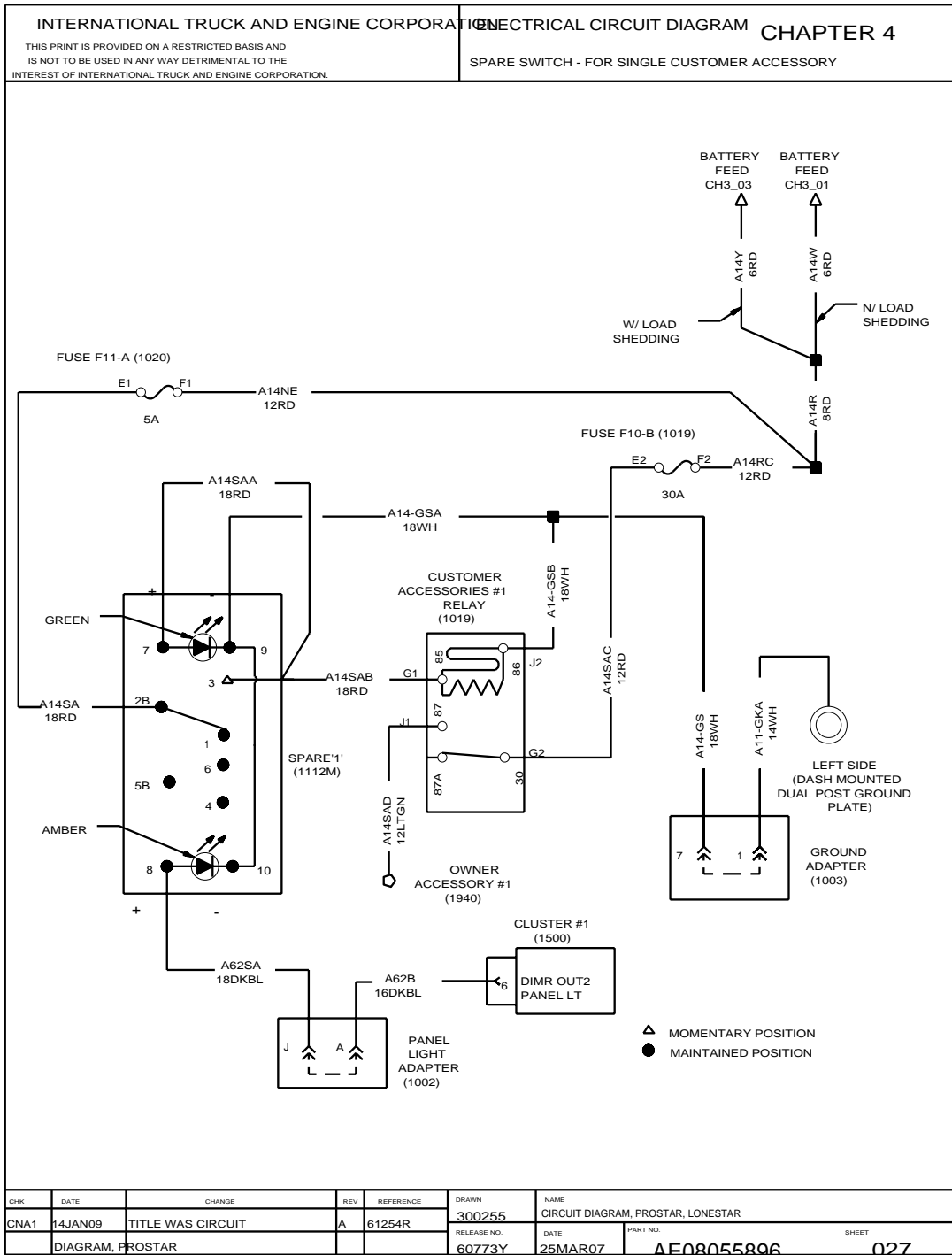


Figure 80 Spare Switch — For Single Customer Accessory

4.31. SPARE SWITCH — FOR DUAL CUSTOMER ACCESSORY, P. 28

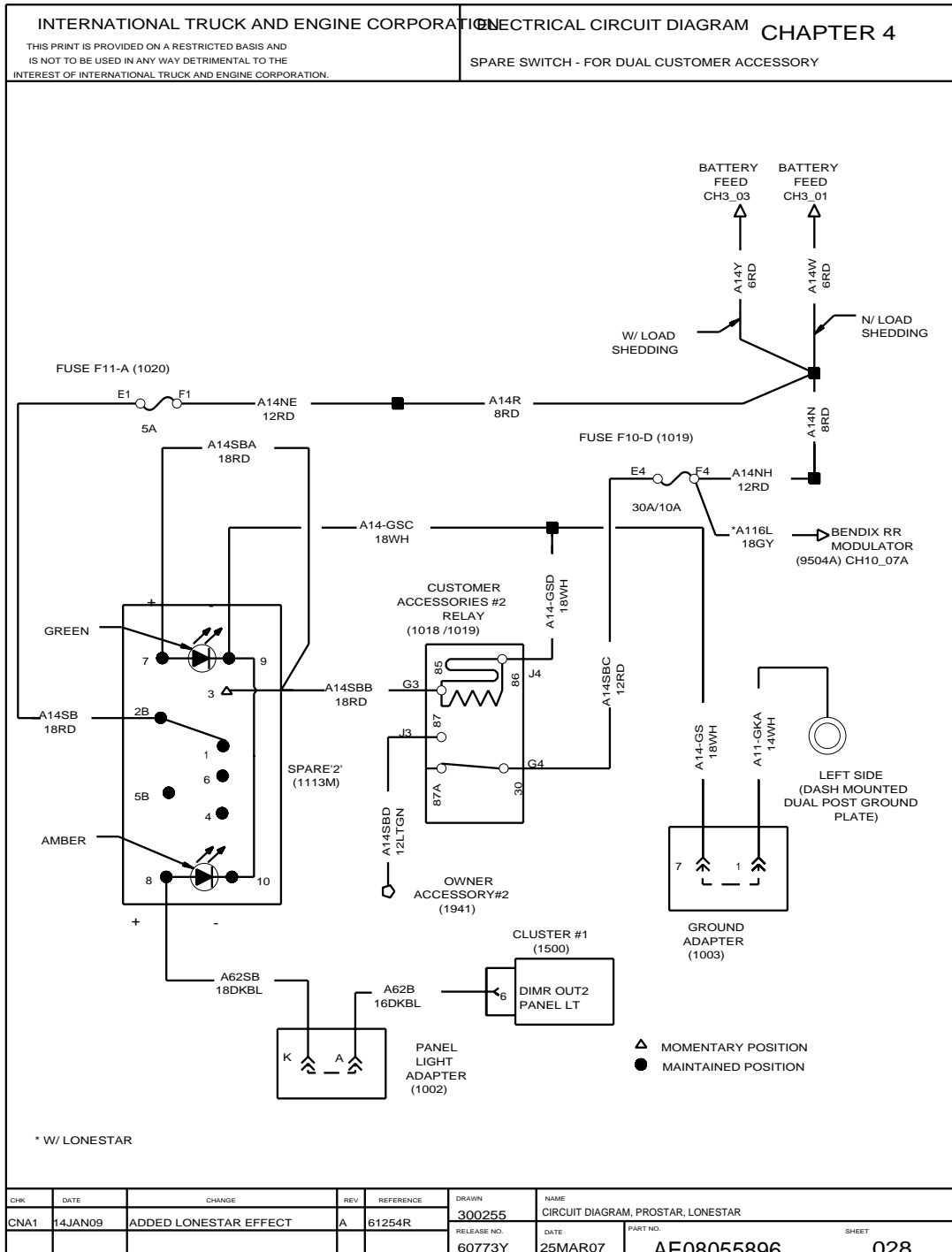


Figure 81 Spare Switch — For Dual Customer Accessory

4.32. EATON VORAD EVT-300 SYSTEM, P. 29

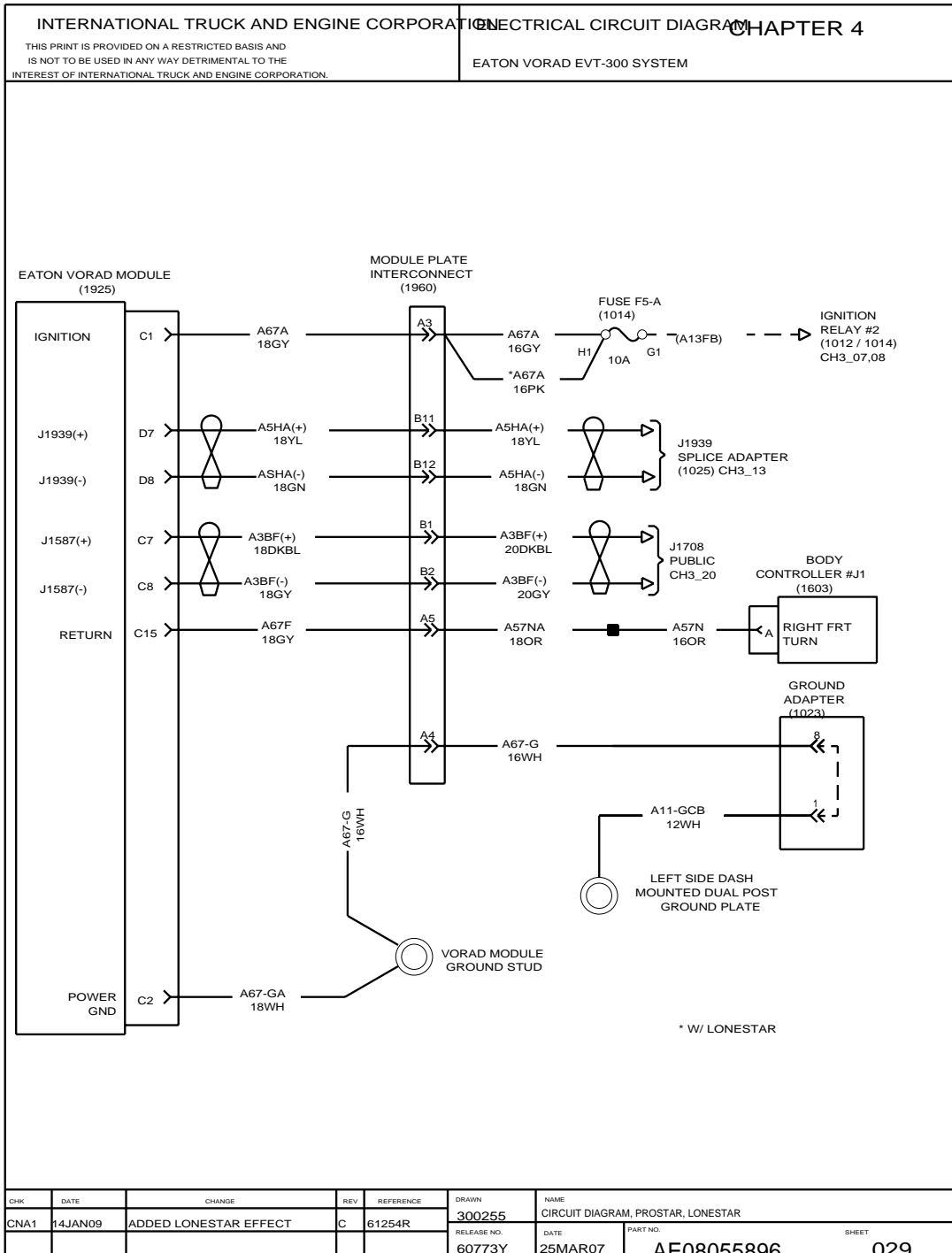


Figure 82 Eaton Vorad EVT-300 System

4.33. EATON VORAD EVT-300 SYSTEM, P. 30

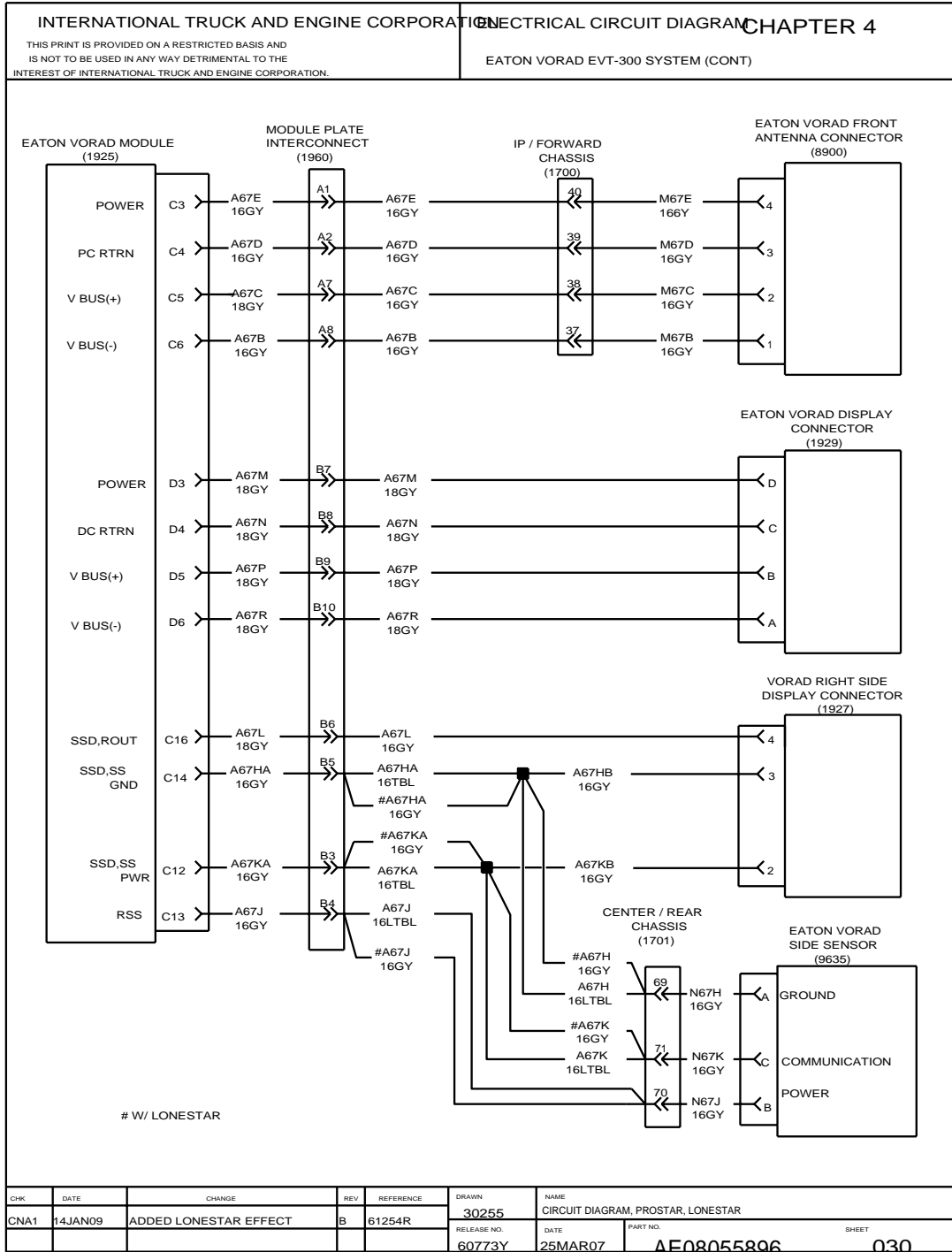


Figure 83 Eaton Vorad EVT-300 System

4.34. EATON VORAD VS-400, P. 31

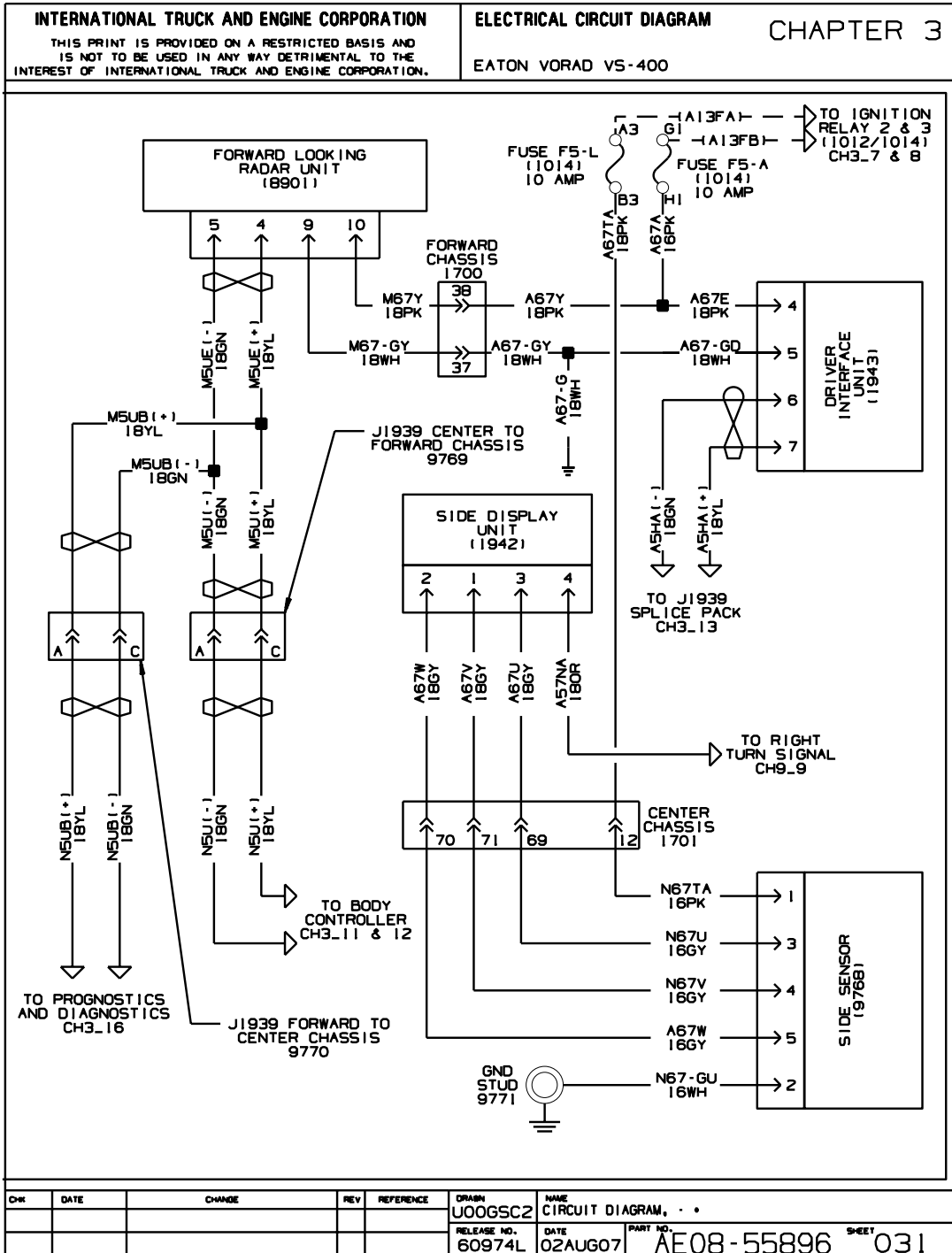


Figure 84 Eaton Vorad VS-400

4.35. WABCO ONGUARD WARNING SYSTEM, P. 31A

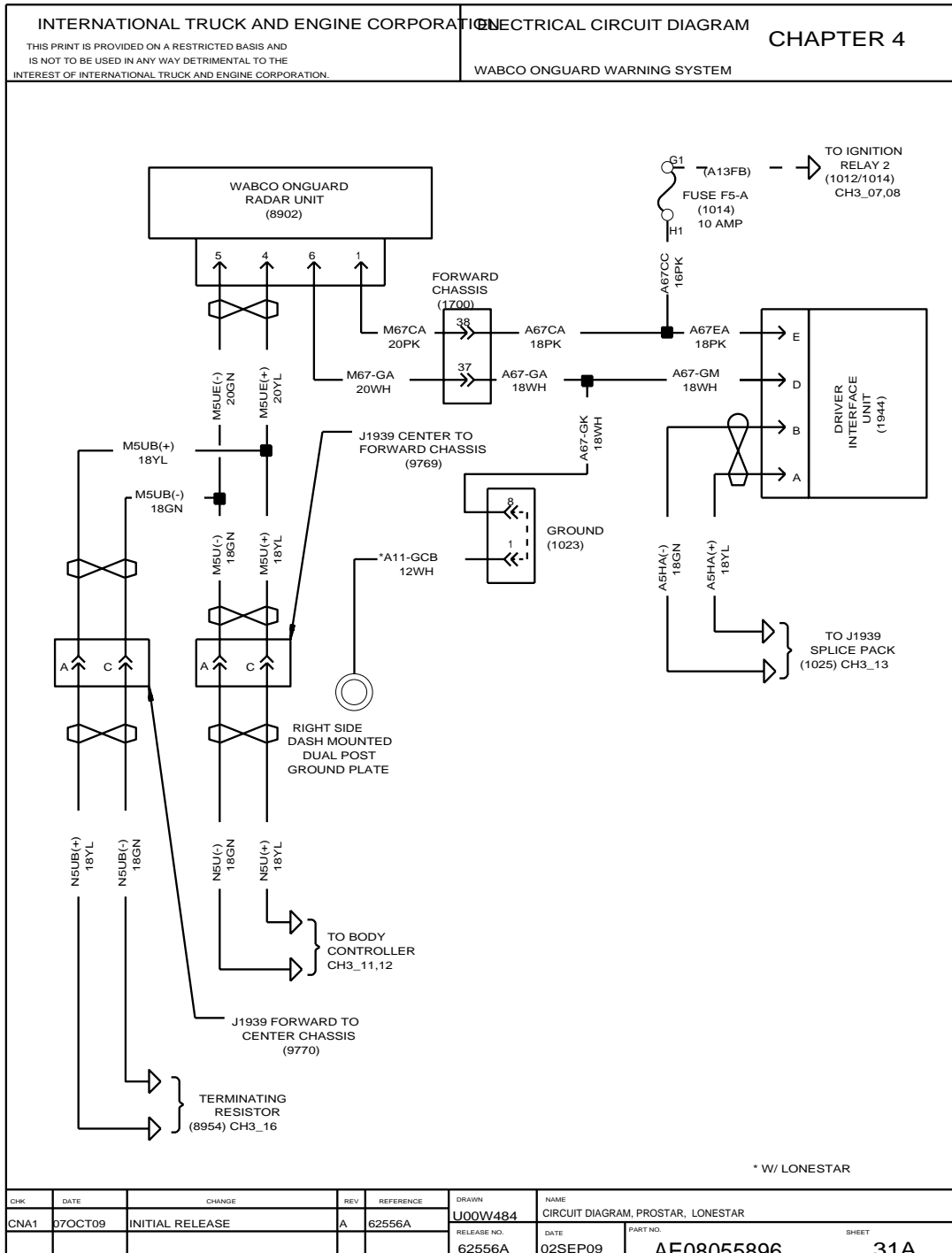


Figure 85 WABCO Onguard Warning System

4.36. AWARE II, P. 32

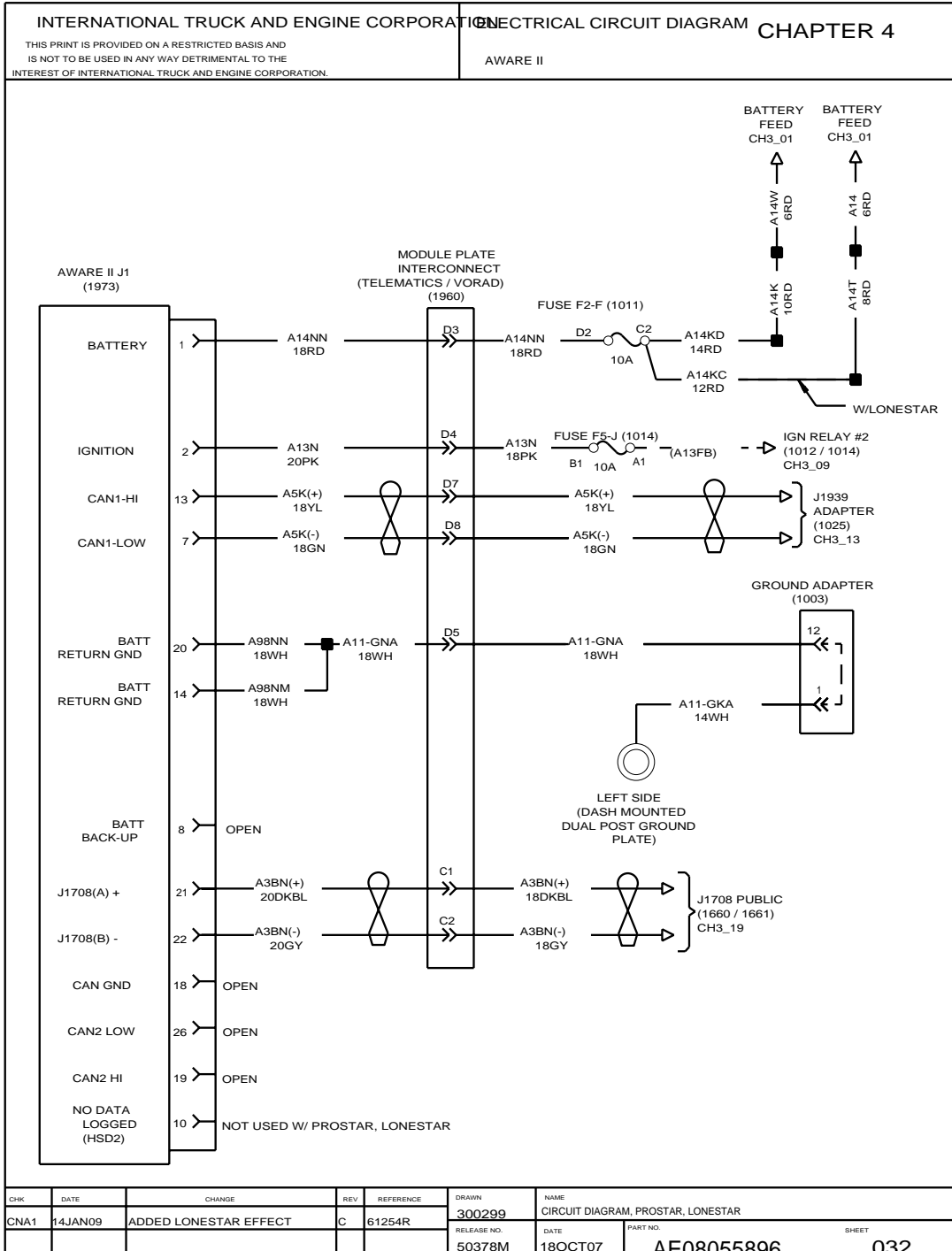


Figure 86 AWARE II

4.37. AWARE II, P. 33

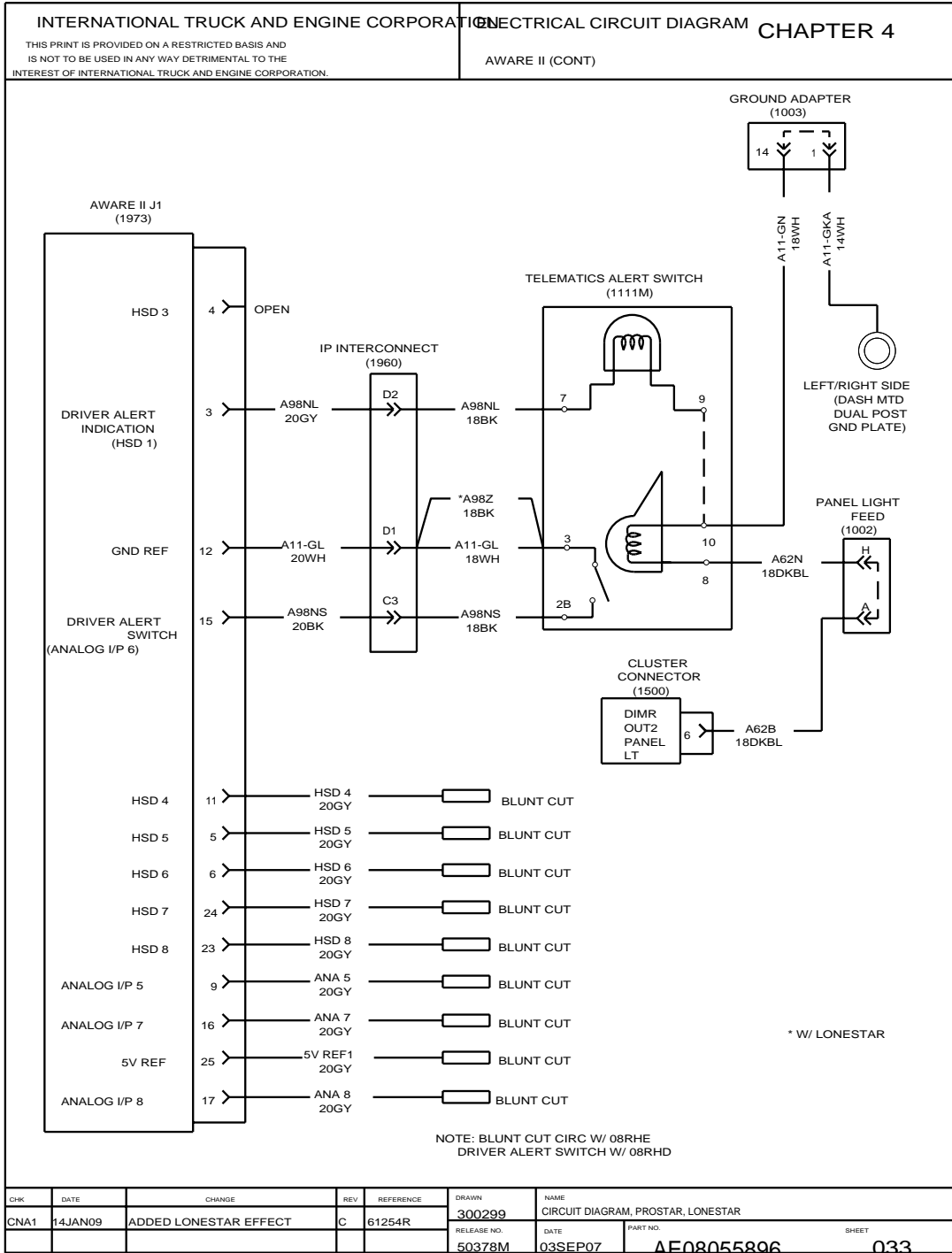


Figure 87 AWARE II

4.38. AWARE II, P. 34

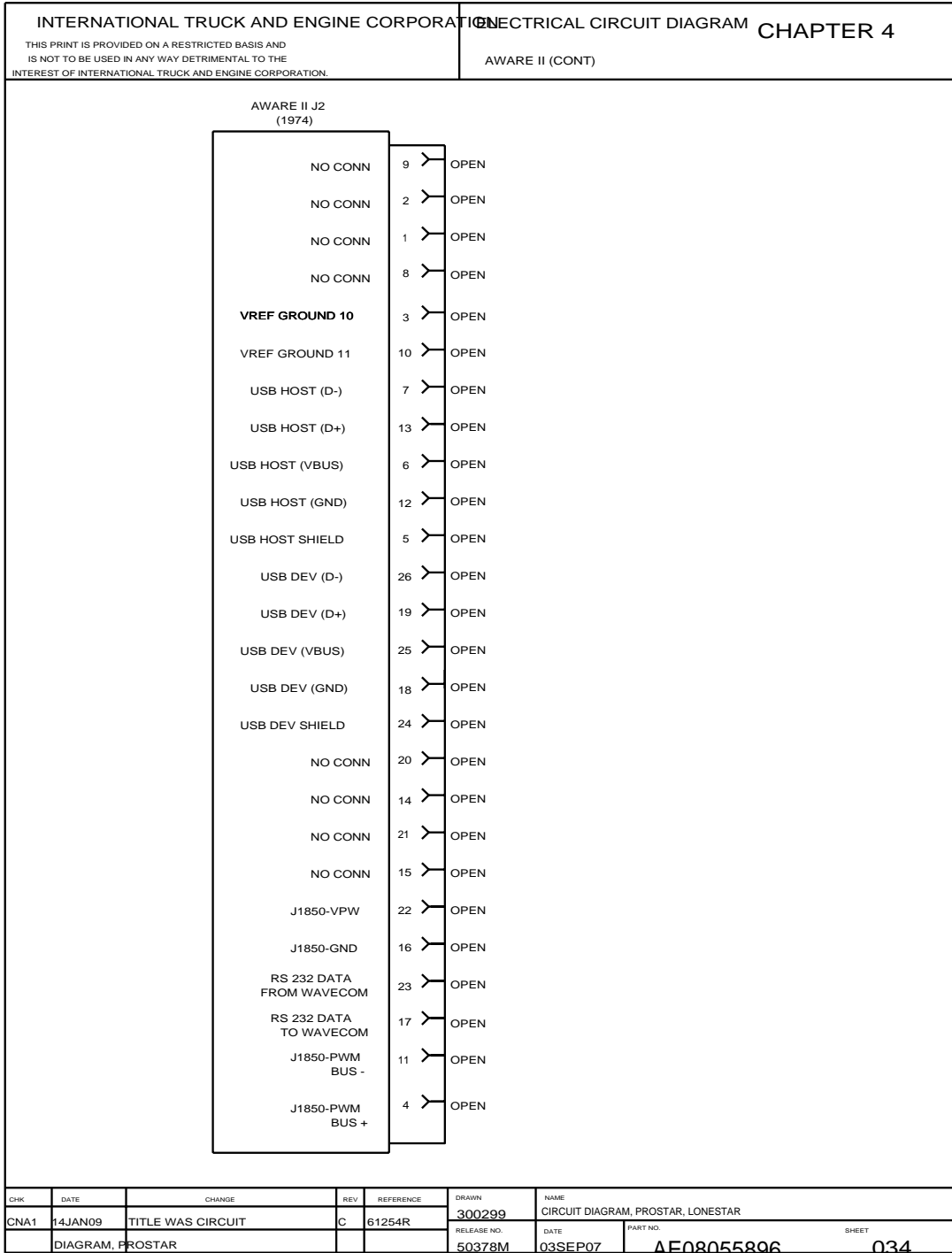


Figure 88 AWARE II

4.39. AWARE II, P. 35

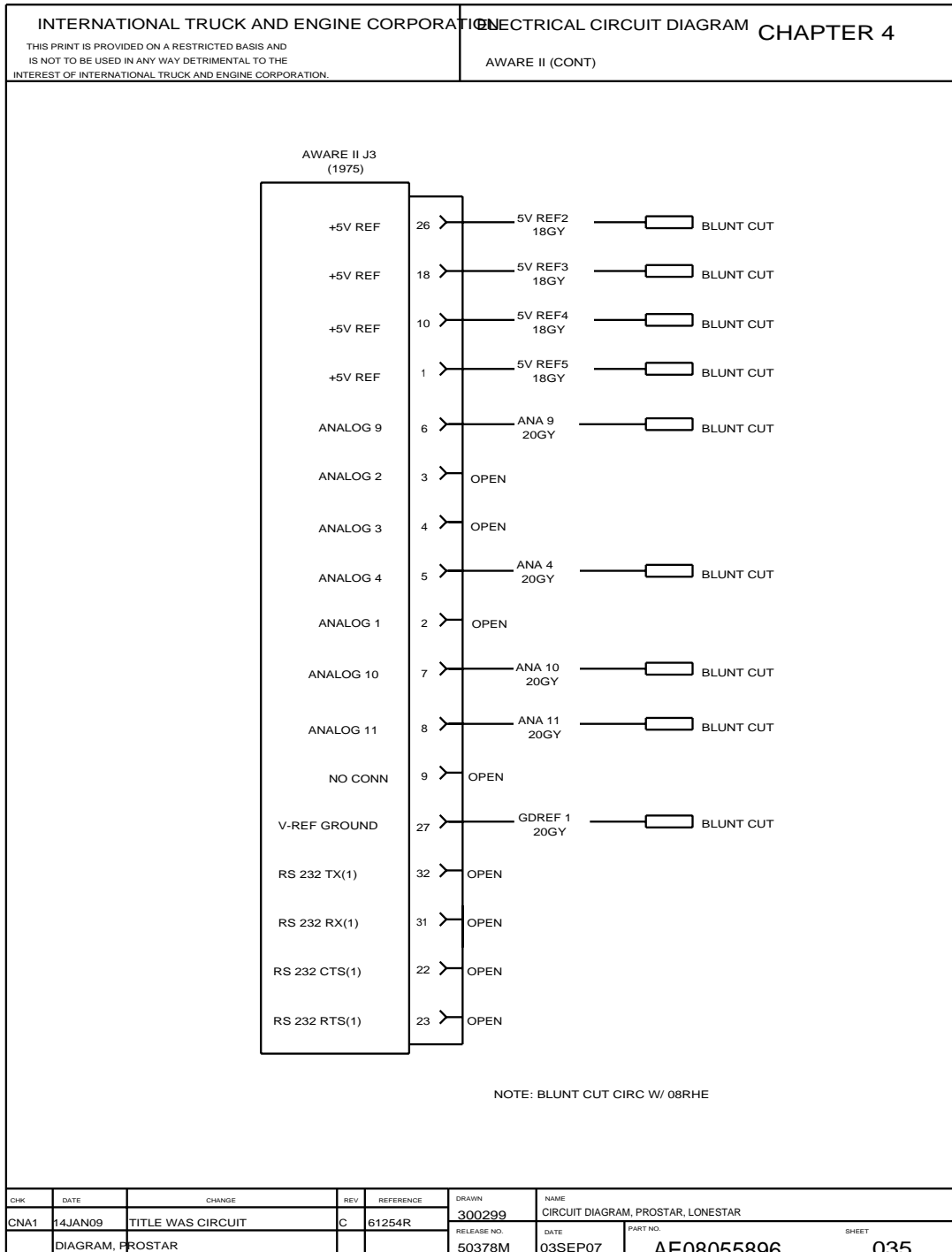


Figure 89 AWARE II

4.40. AWARE II, P. 36

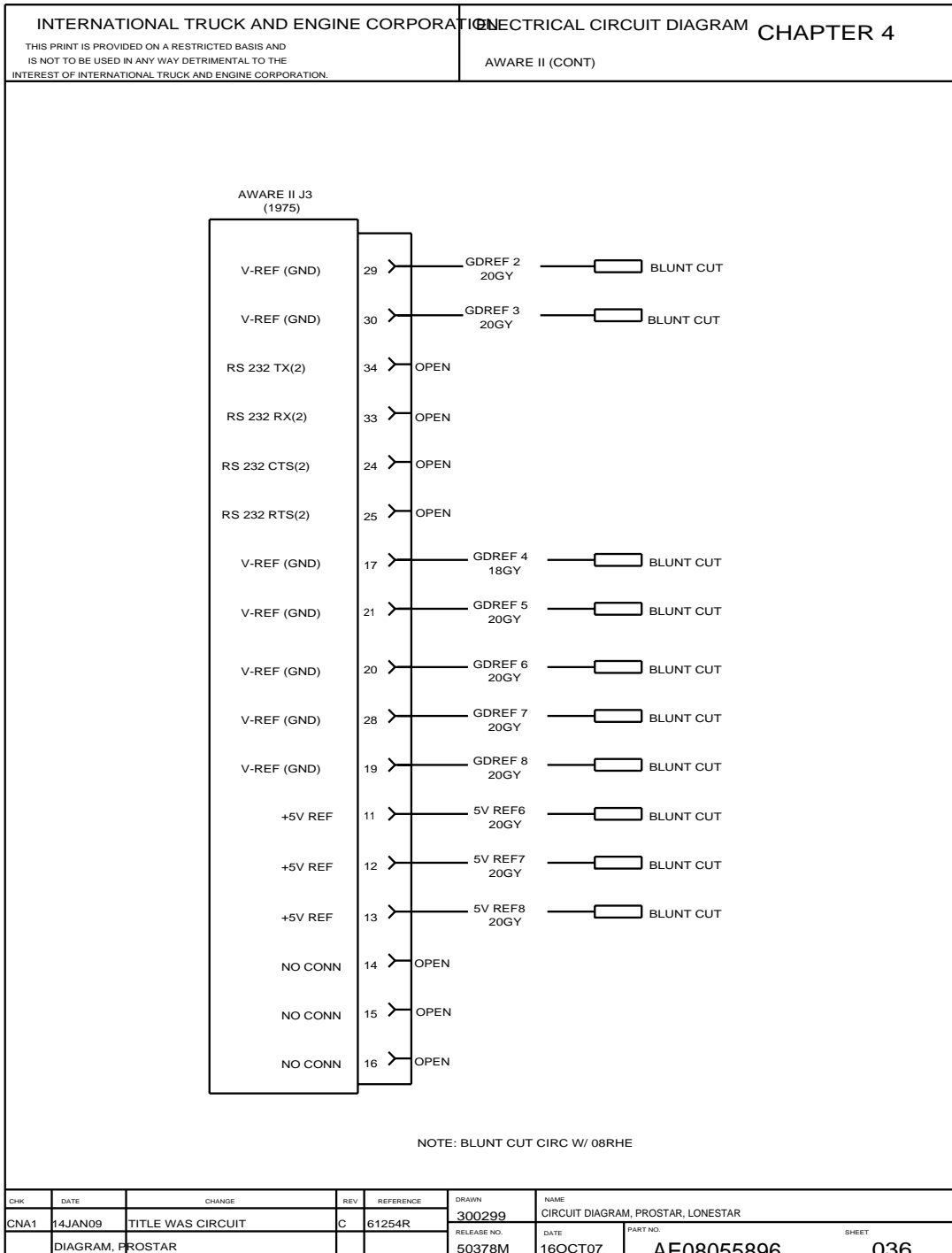


Figure 90 AWARE II

4.41. QUALCOMM OMNIVISION, P. 37

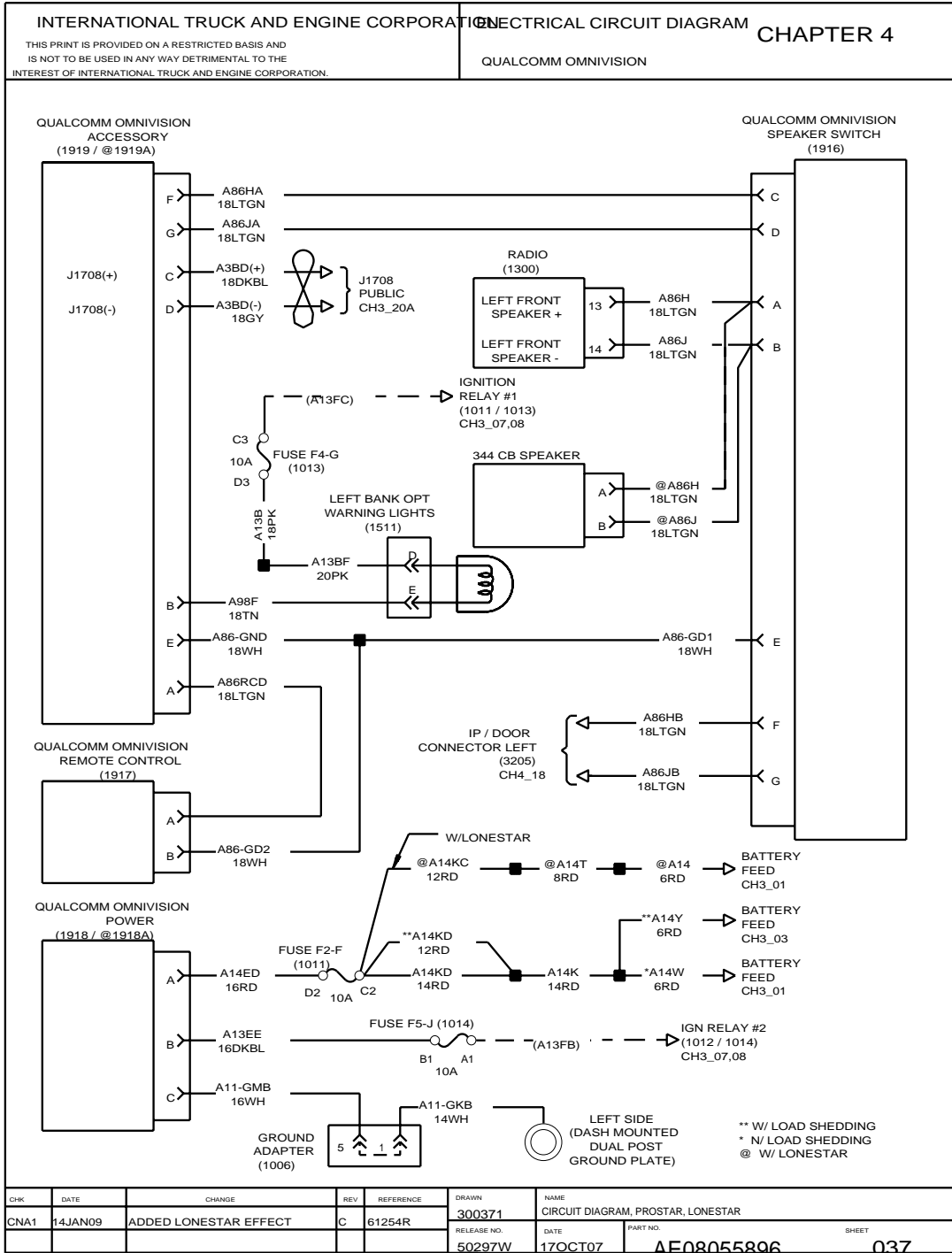


Figure 91 Qualcomm Omnivision

4.42. QUALCOMM OMNIVISION, P. 38

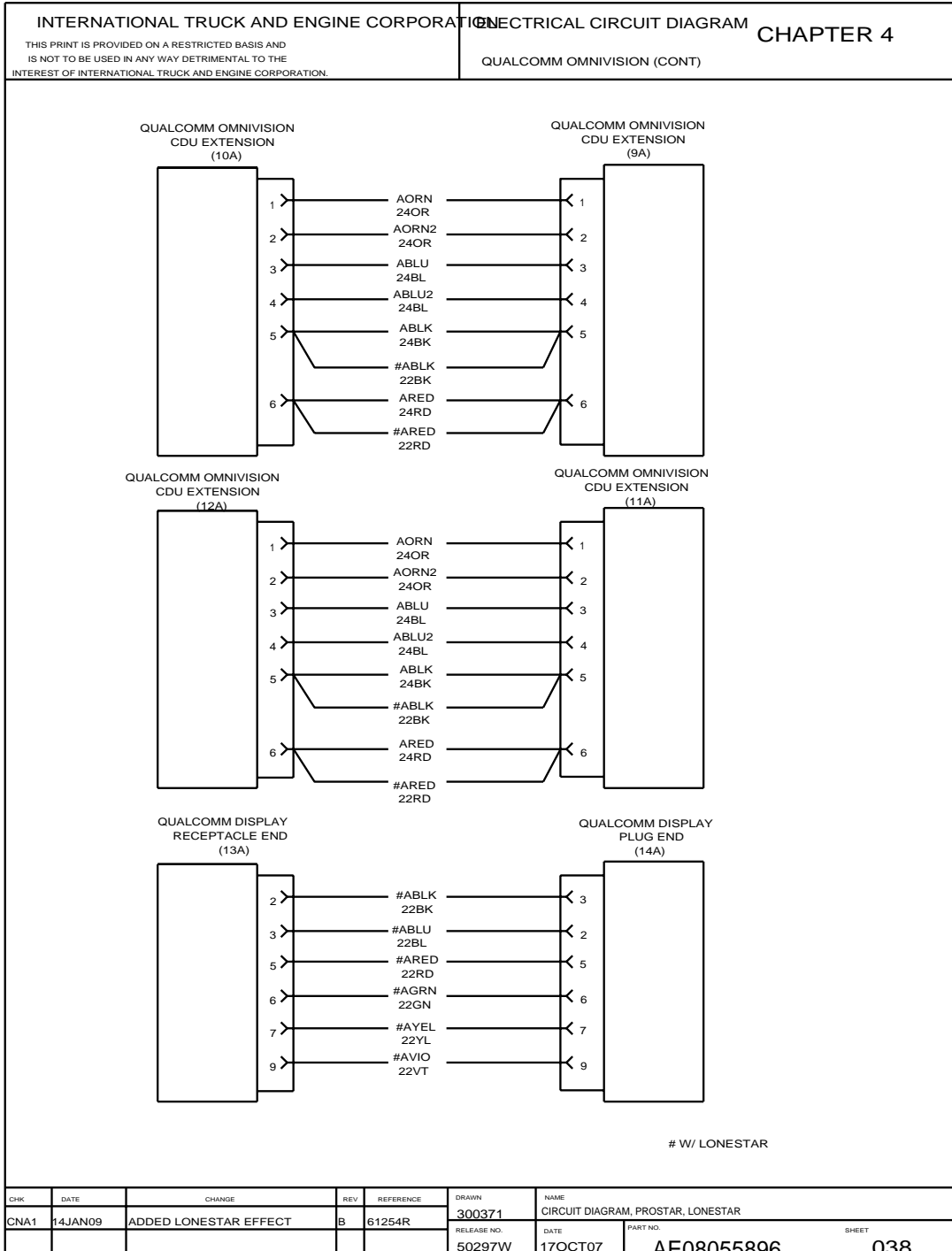


Figure 92 Qualcomm Omnivision

4.43. MOTIENT MOBILE MAX, P. 39

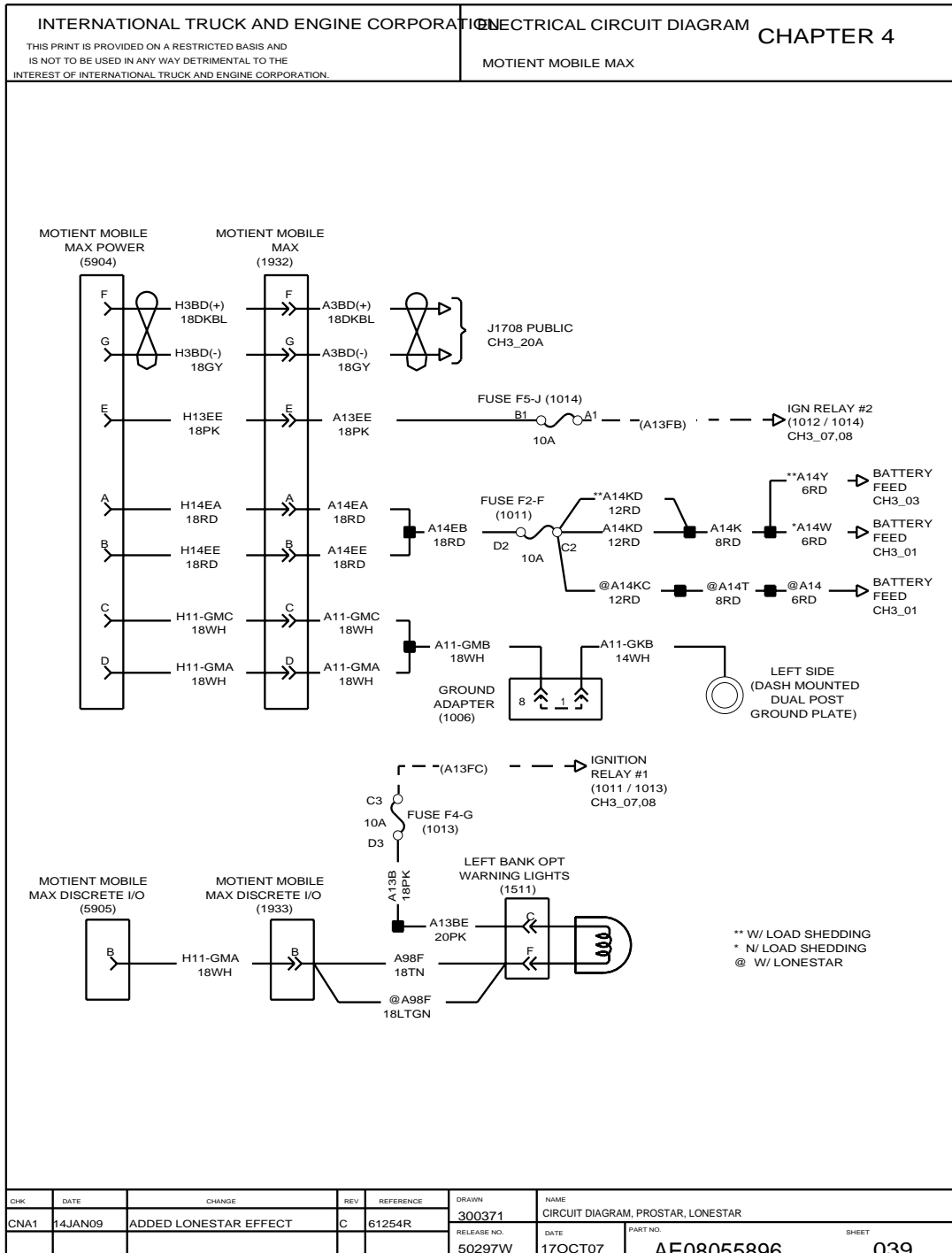


Figure 93 Motient Mobile Max

4.44. REMOTE RADIO — N/AMP AND N/WIRED REMOTE AND N/DRIVER INTERFACE DISPLAY, P. 40

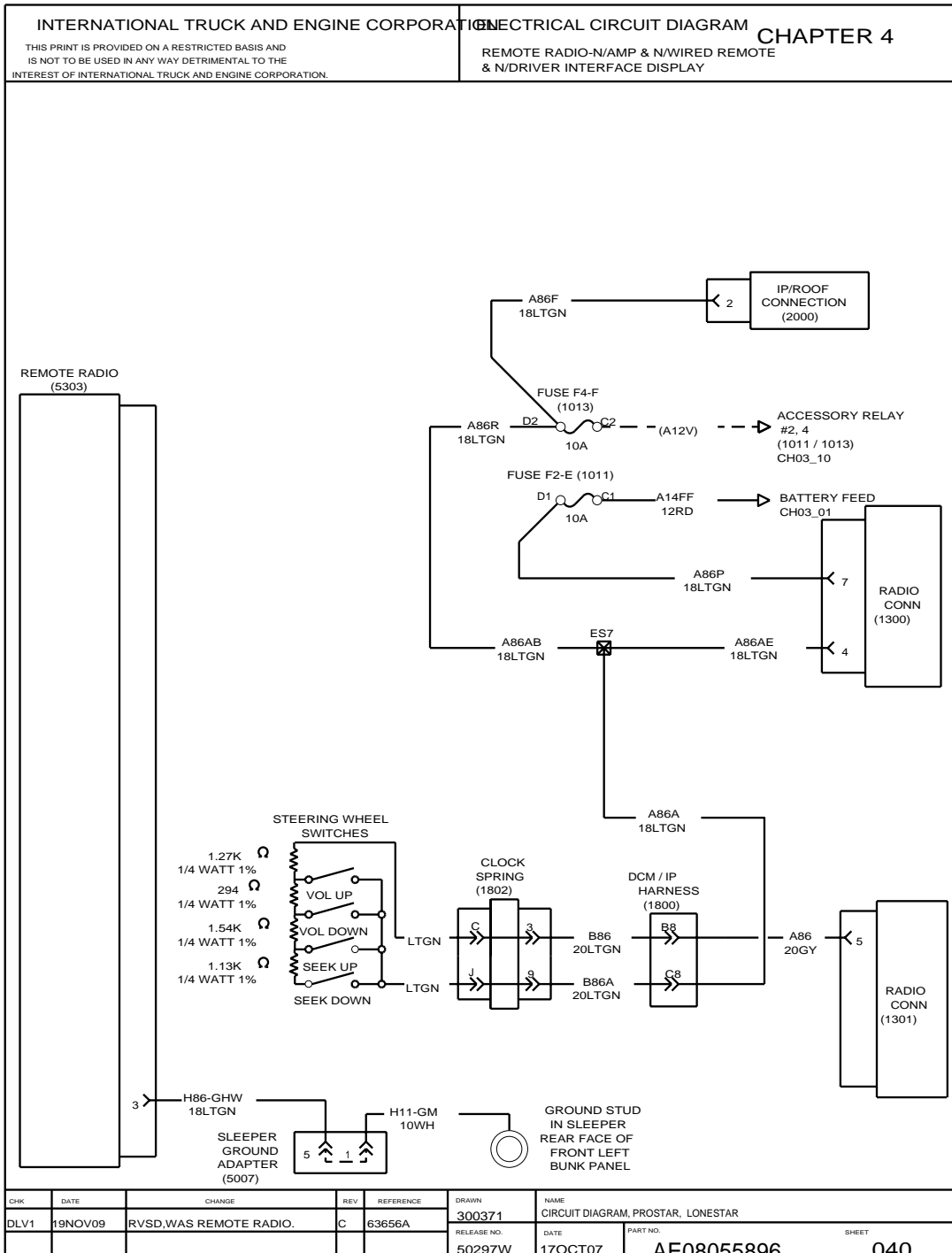


Figure 94 Remote Radio — N/AMP and N/Wired Remote and N/Driver Interface Display

**4.45. REMOTE RADIO — W/AMP AND N/WIRED REMOTE AND N/DRIVER INTERFACE DISPLAY, P. 40A**

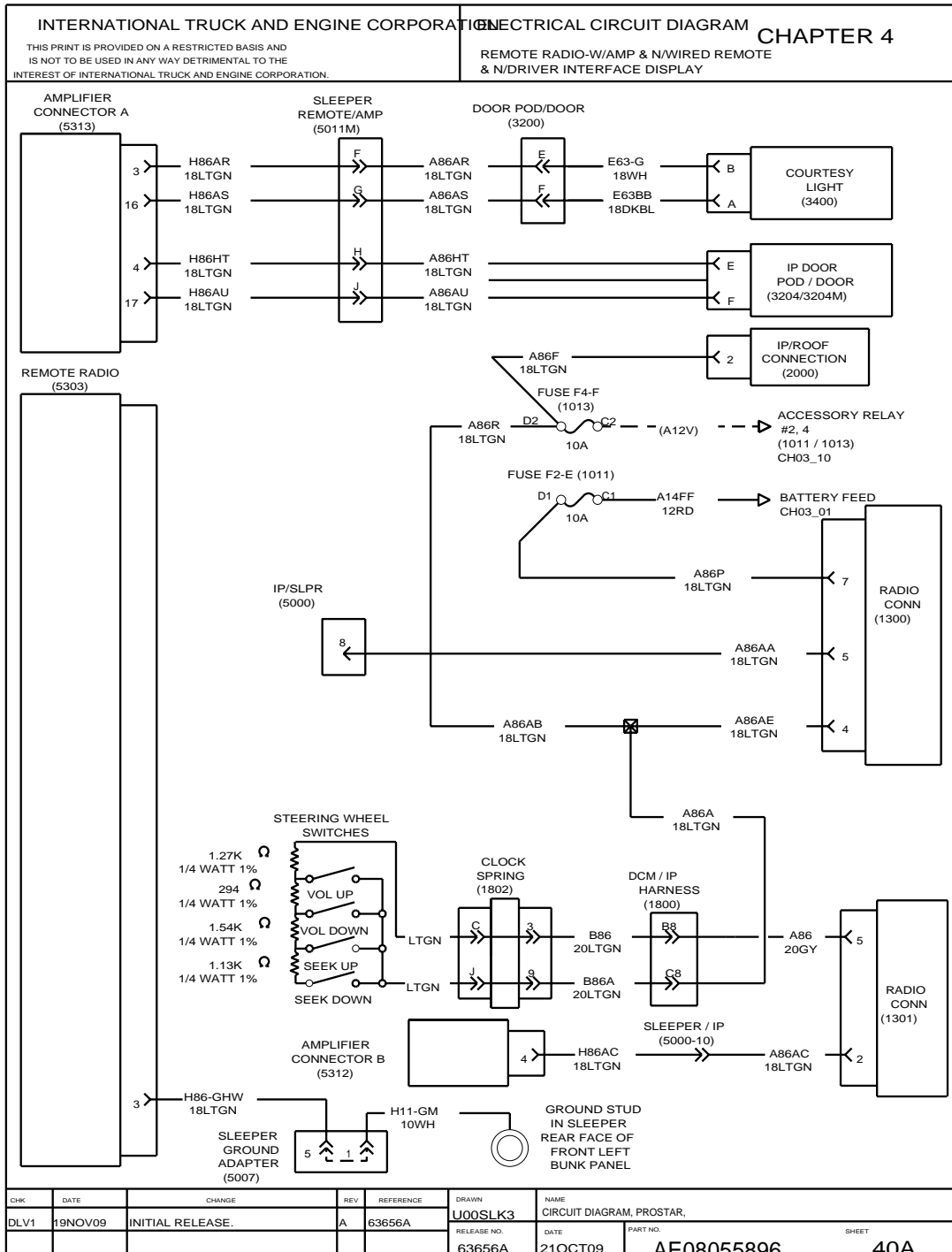


Figure 95 Remote Radio — W/AMP and N/Wired Remote and N/Driver Interface Display

4.46. REMOTE RADIO — N/AMP AND W/WIRED REMOTE AND N/DRIVER INTERFACE DISPLAY, P. 40B

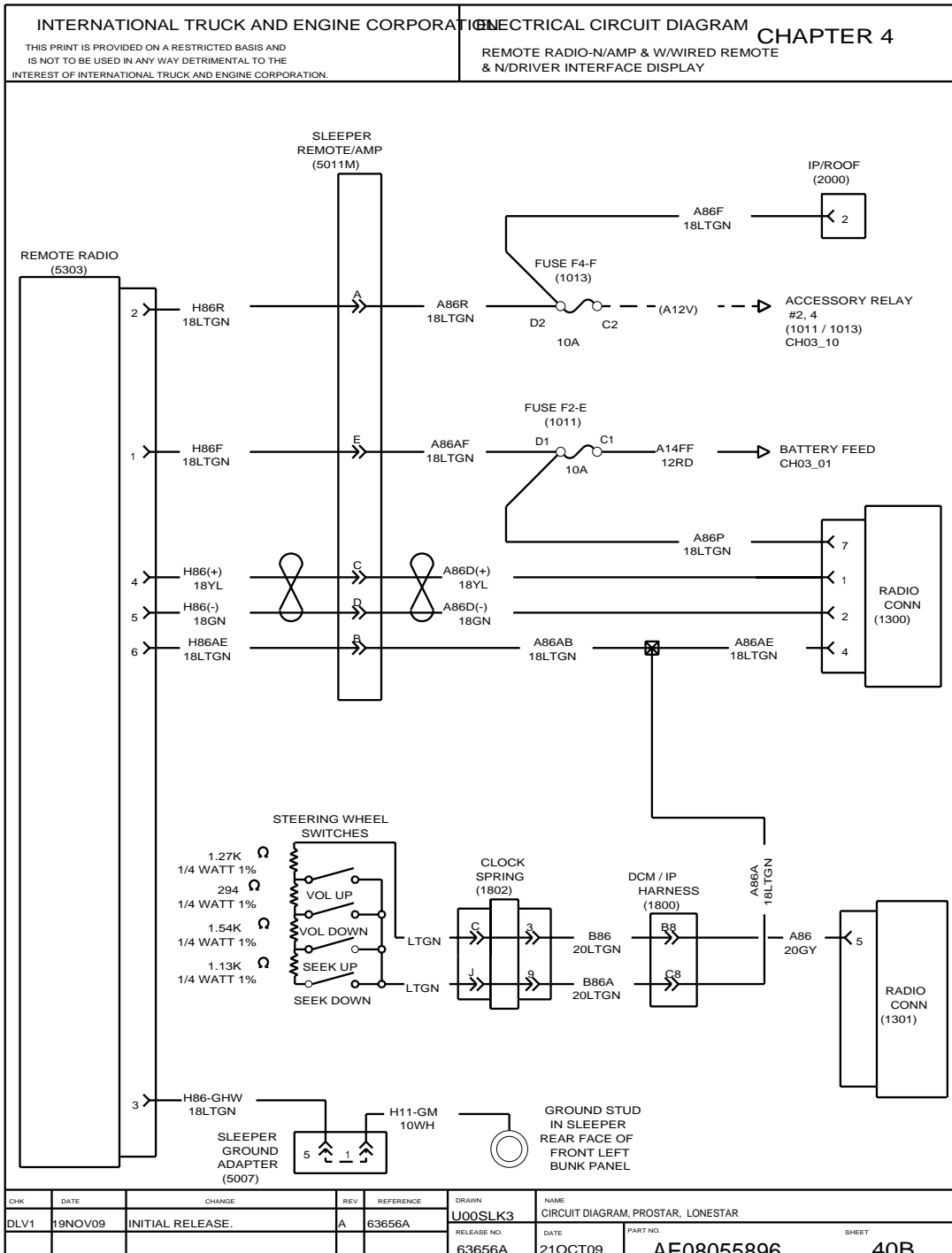


Figure 96 Remote Radio — N/AMP and W/Wired Remote and N/Driver Interface Display

**4.47. REMOTE RADIO — W/AMP AND W/WIRED REMOTE AND N/DRIVER INTERFACE DISPLAY, P. 40C**

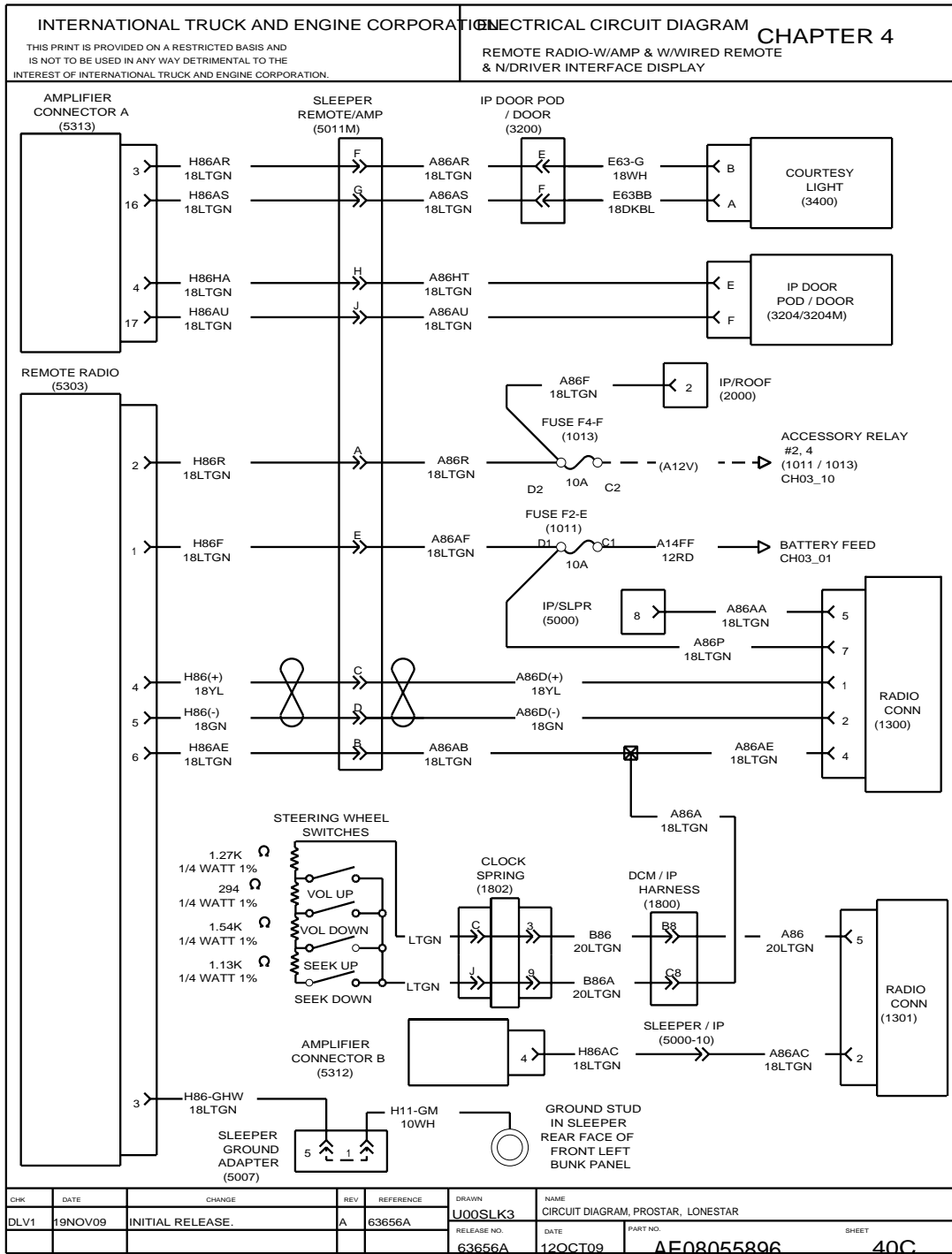


Figure 97 Remote Radio — W/AMP and W/Wired Remote and N/Driver Interface Display

4.48. REMOTE RADIO — N/AMP AND N/WIRED REMOTE AND W/DRIVER INTERFACE DISPLAY, P. 41

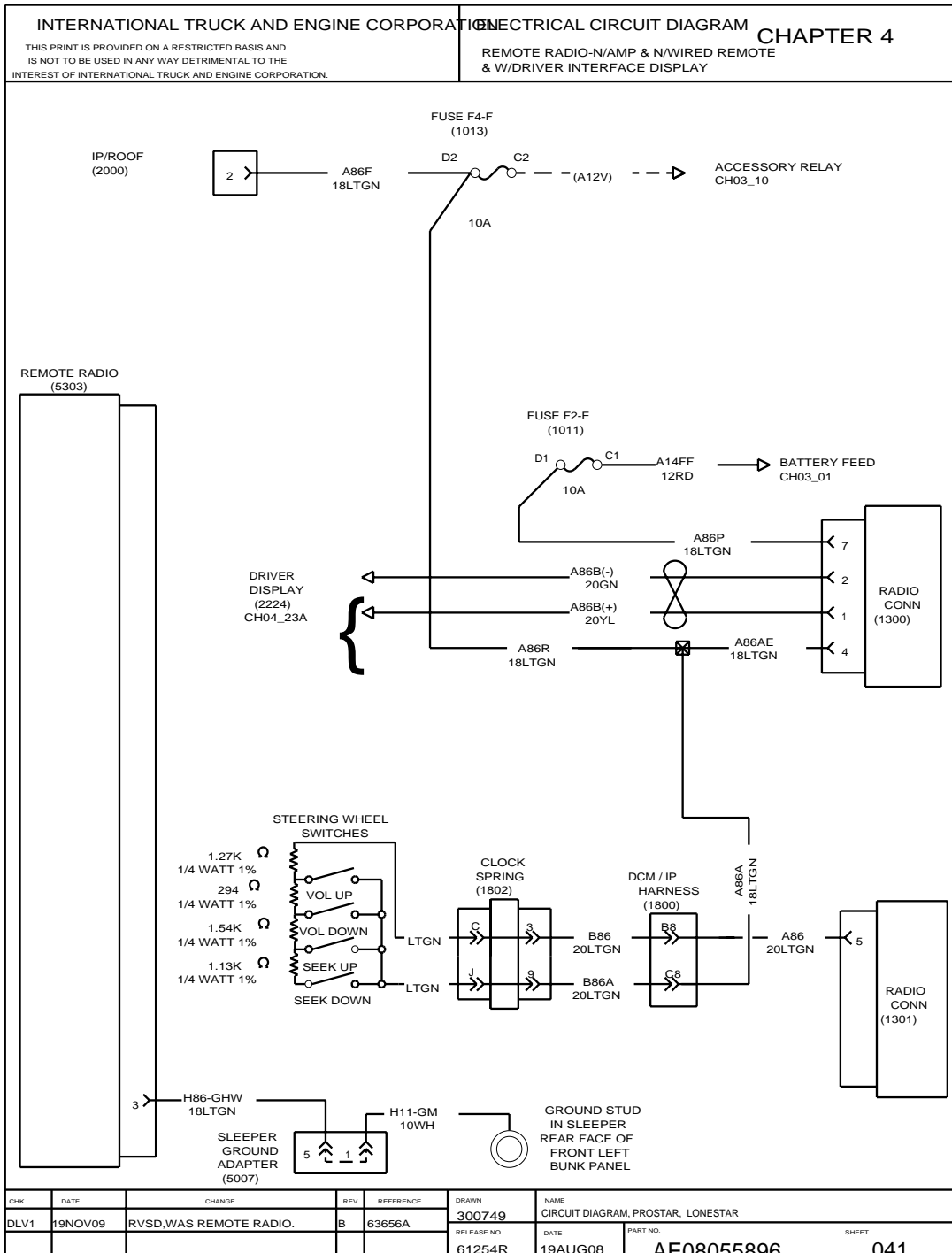


Figure 98 Remote Radio — N/AMP and N/Wired Remote and W/Driver Interface Display

**4.49. REMOTE RADIO — W/AMP AND N/WIRED REMOTE AND W/DRIVER INTERFACE DISPLAY, P. 41A**

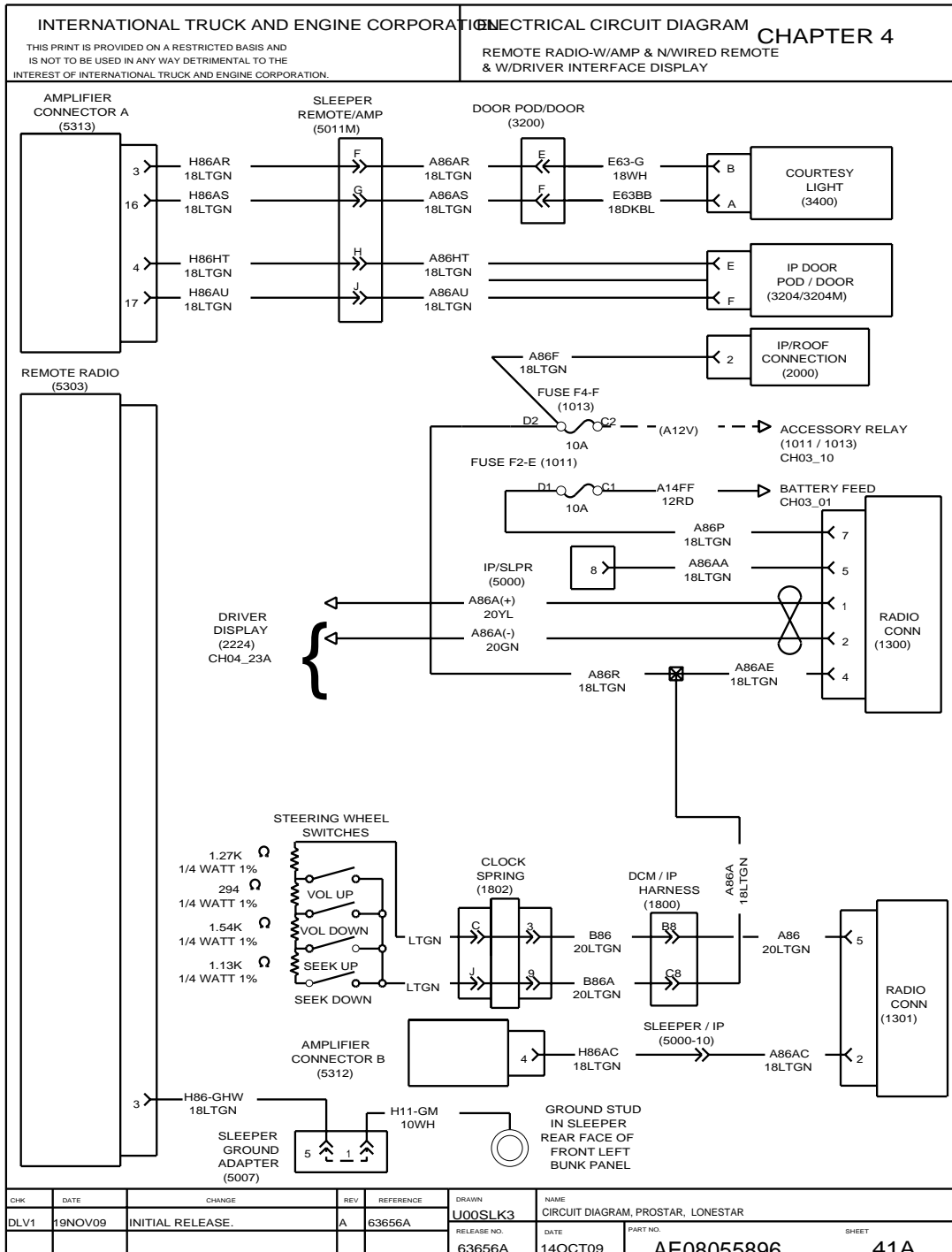


Figure 99 Remote Radio — W/AMP and N/Wired Remote and W/Driver Interface Display

4.50. REMOTE RADIO — N/AMP AND W/WIRED REMOTE AND W/DRIVER INTERFACE DISPLAY, P. 41B

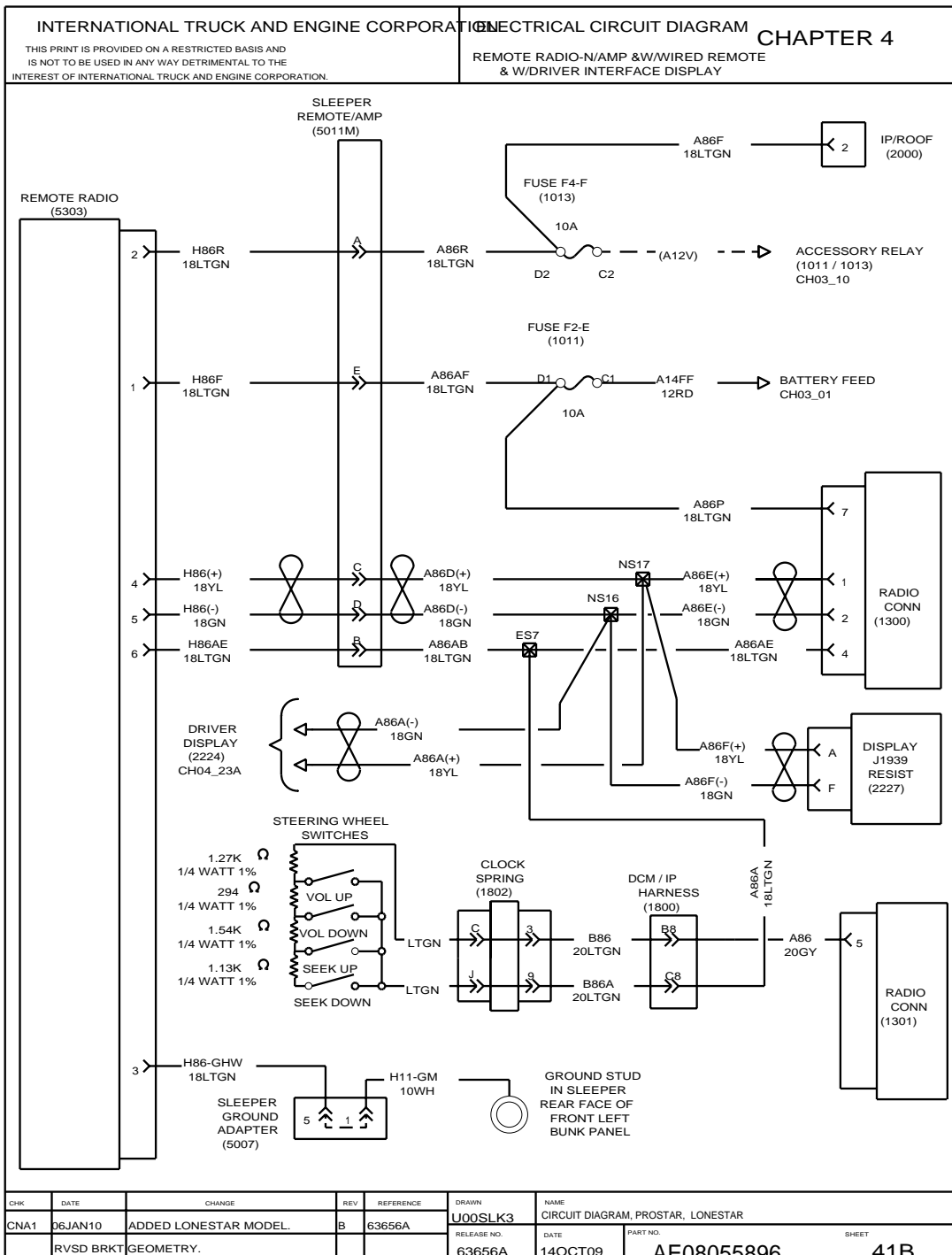


Figure 100 Remote Radio — N/AMP and W/Wired Remote and W/Driver Interface Display

**4.51. REMOTE RADIO — W/AMP AND W/WIRED REMOTE AND W/DRIVER INTERFACE DISPLAY, P. 41C**

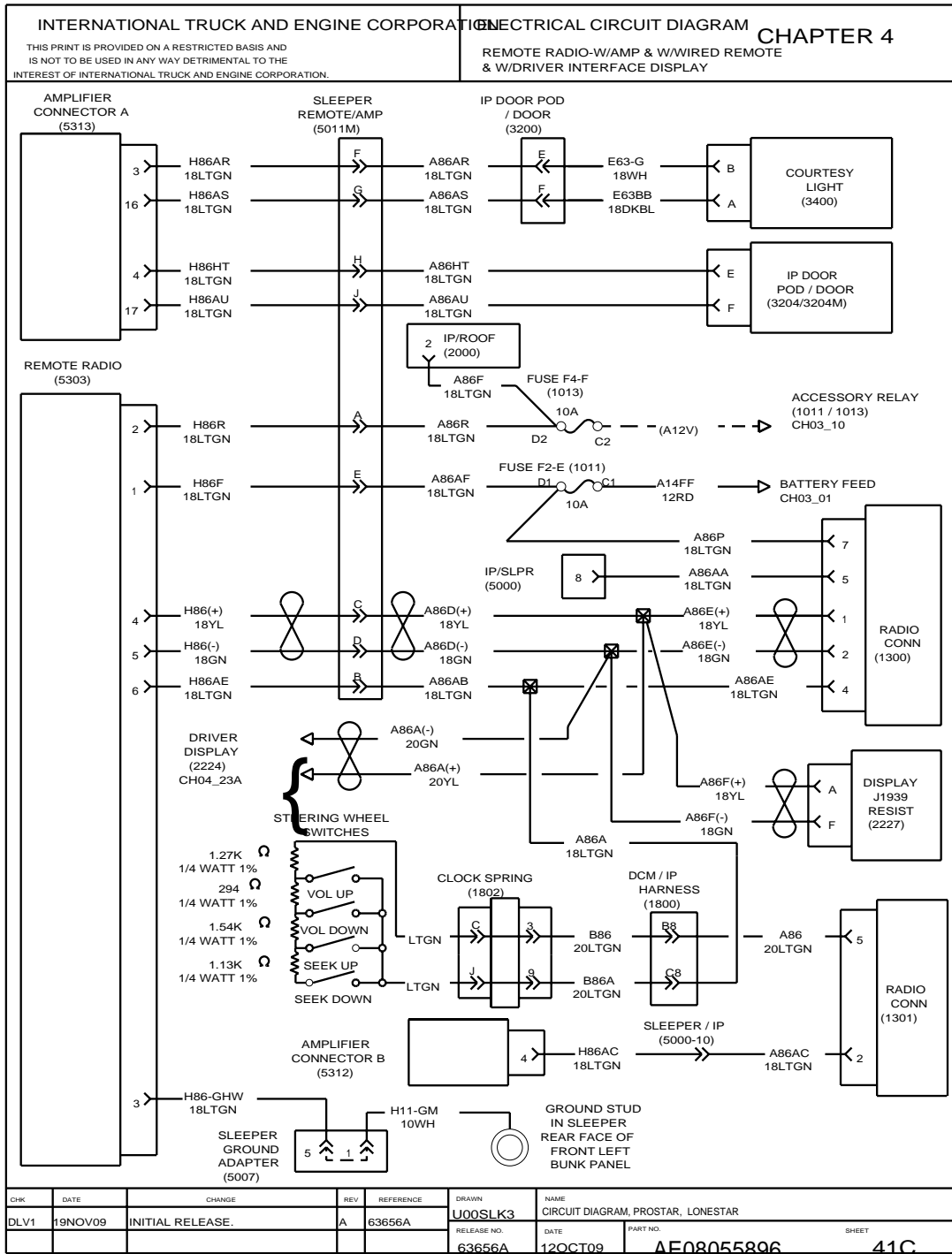


Figure 101 Remote Radio — W/AMP and W/Wired Remote and W/Driver Interface Display

## 5. CHARGING AND CRANKING SYSTEM (CHAPTER 5)

### 5.1. MANUAL TRANSMISSION, P. 1

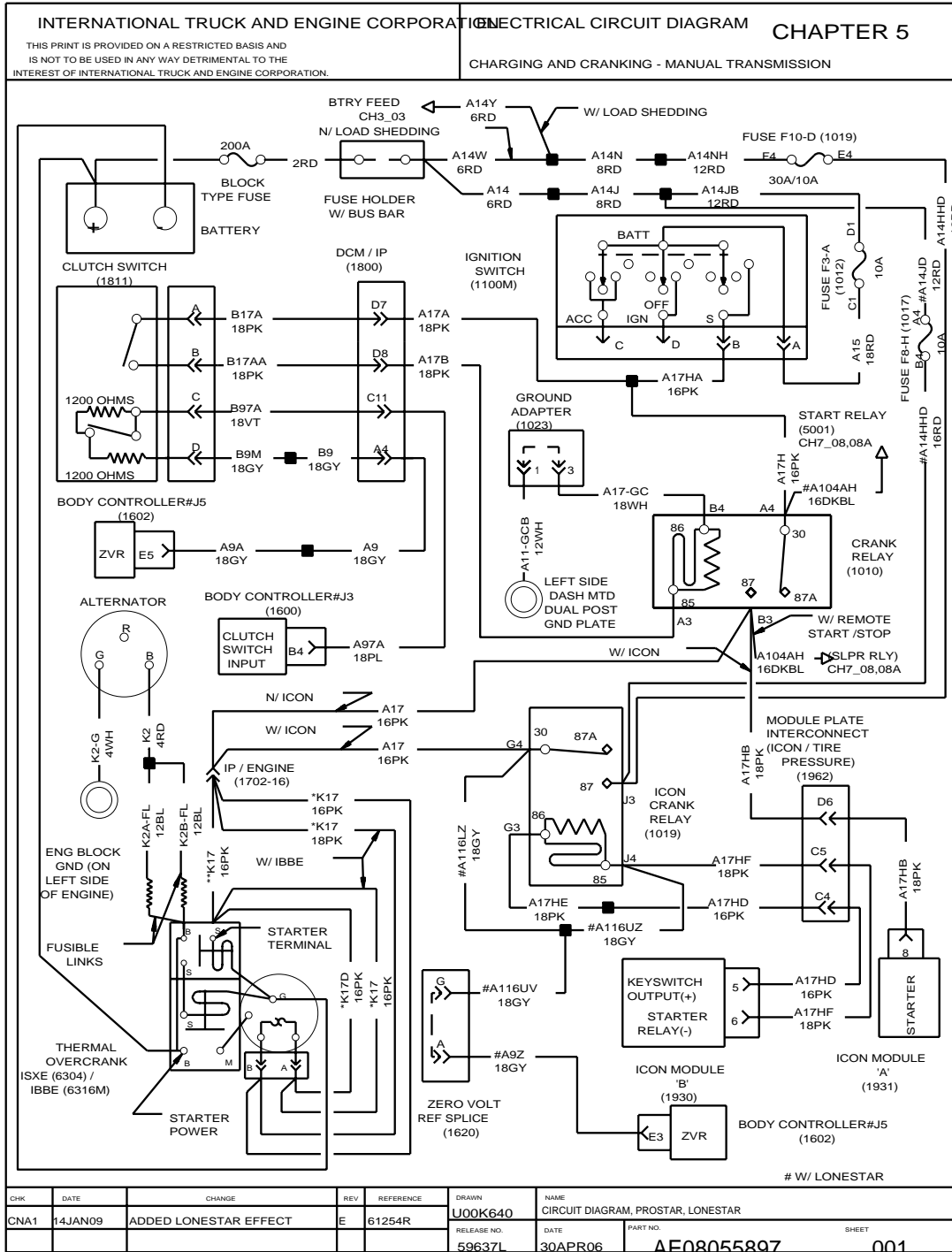


Figure 102 Manual Transmission

5.2. MANUAL TRANSMISSION (CAT ENGINE), P. 1A

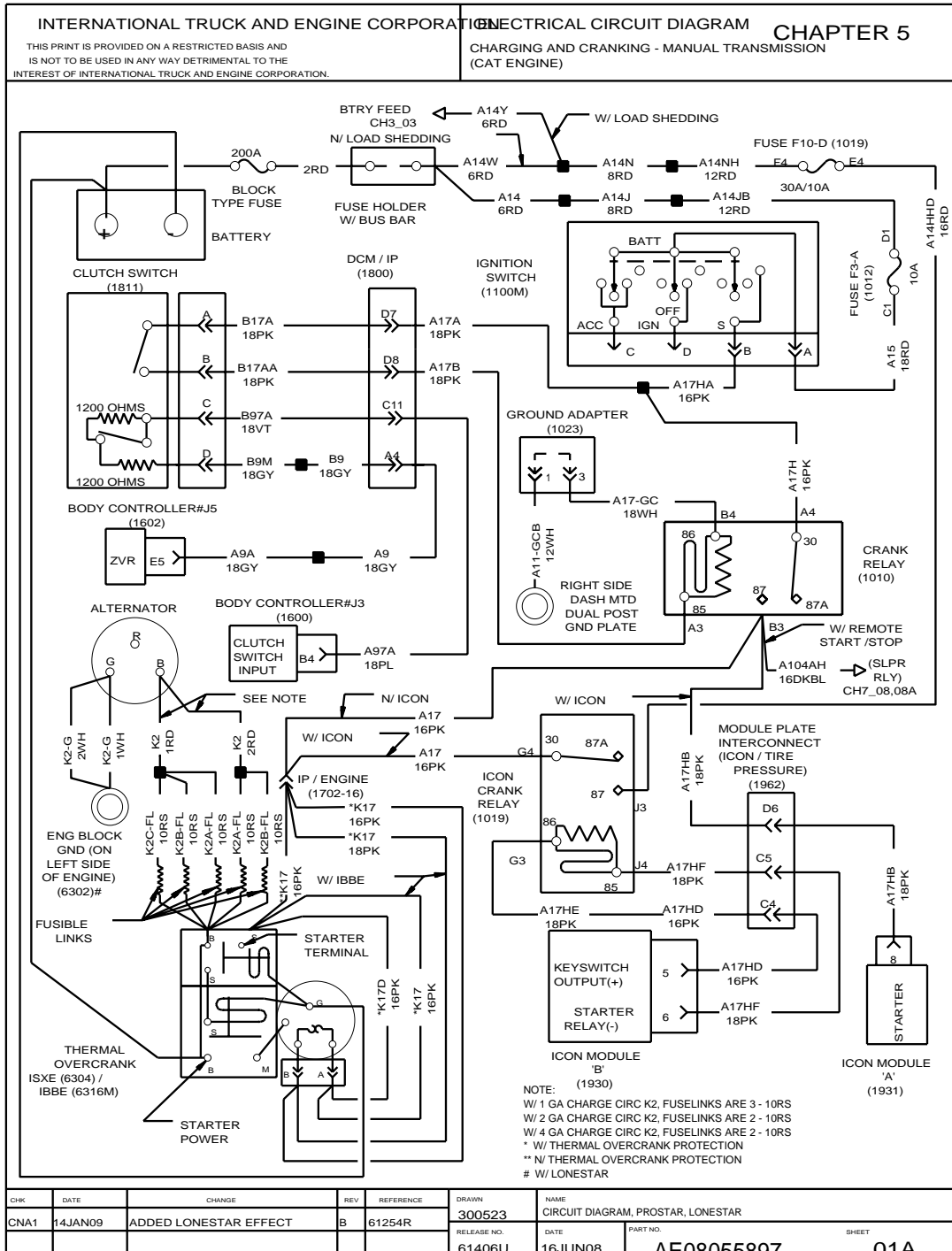


Figure 103 Manual Transmission (Cat Engine)

5.3. AUTOMATIC TRANSMISSION, P. 2

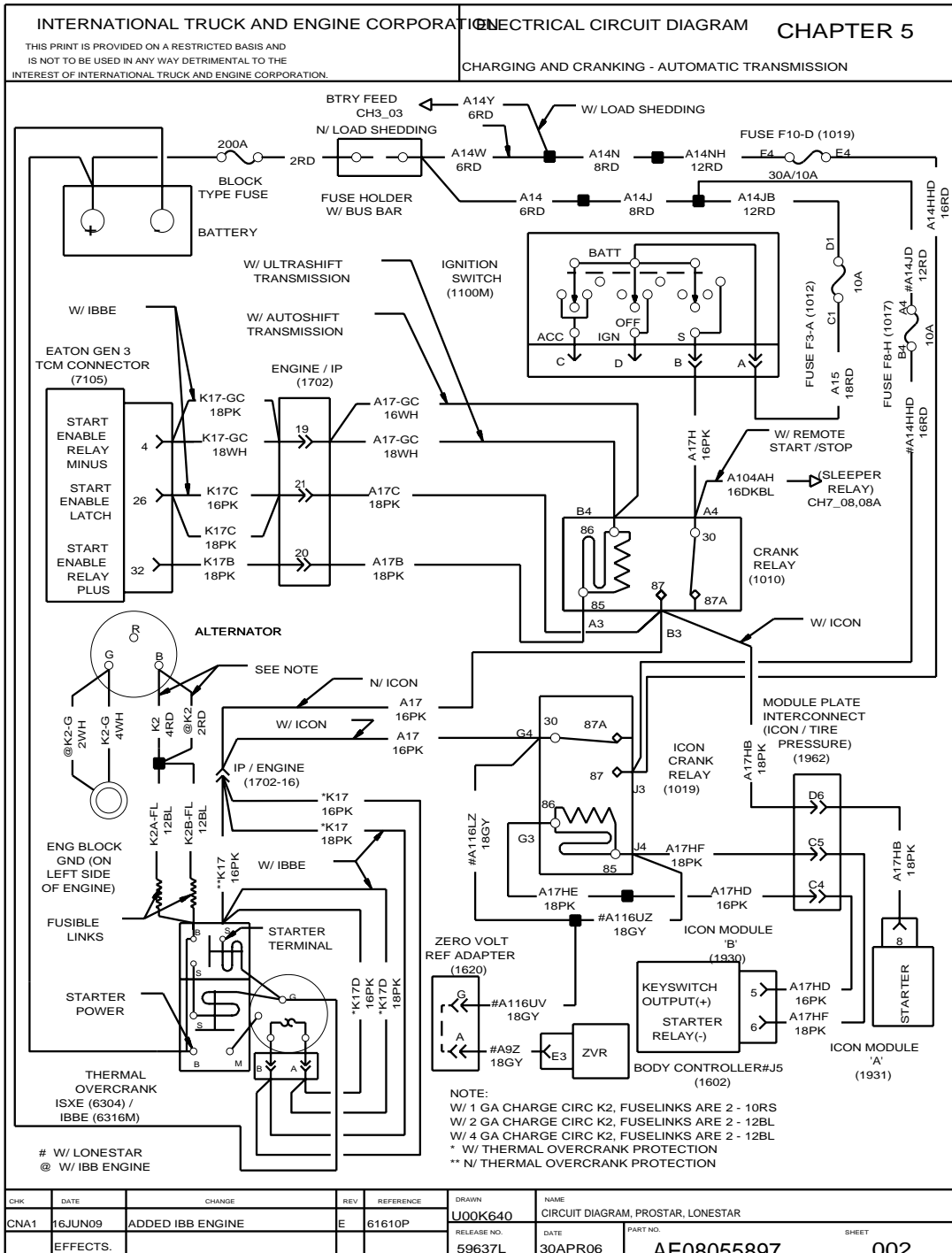


Figure 104 Automatic Transmission

5.4. AUTOMATIC TRANSMISSION (CAT ENGINE), P. 2A

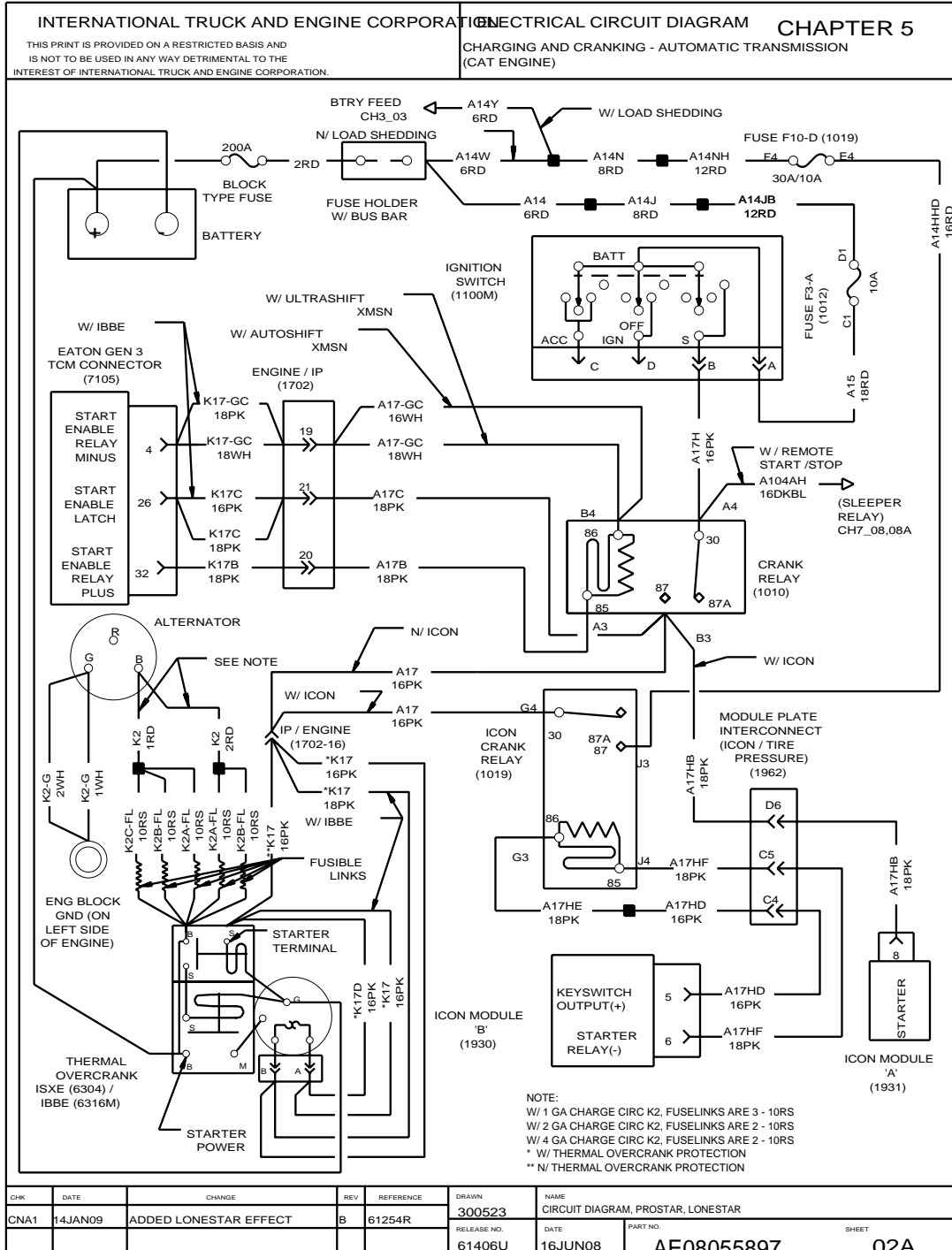


Figure 105 Automatic Transmission (Cat Engine)



5.6. FREEDOMLINE TRANSMISSION (CAT ENGINE), P. 3A

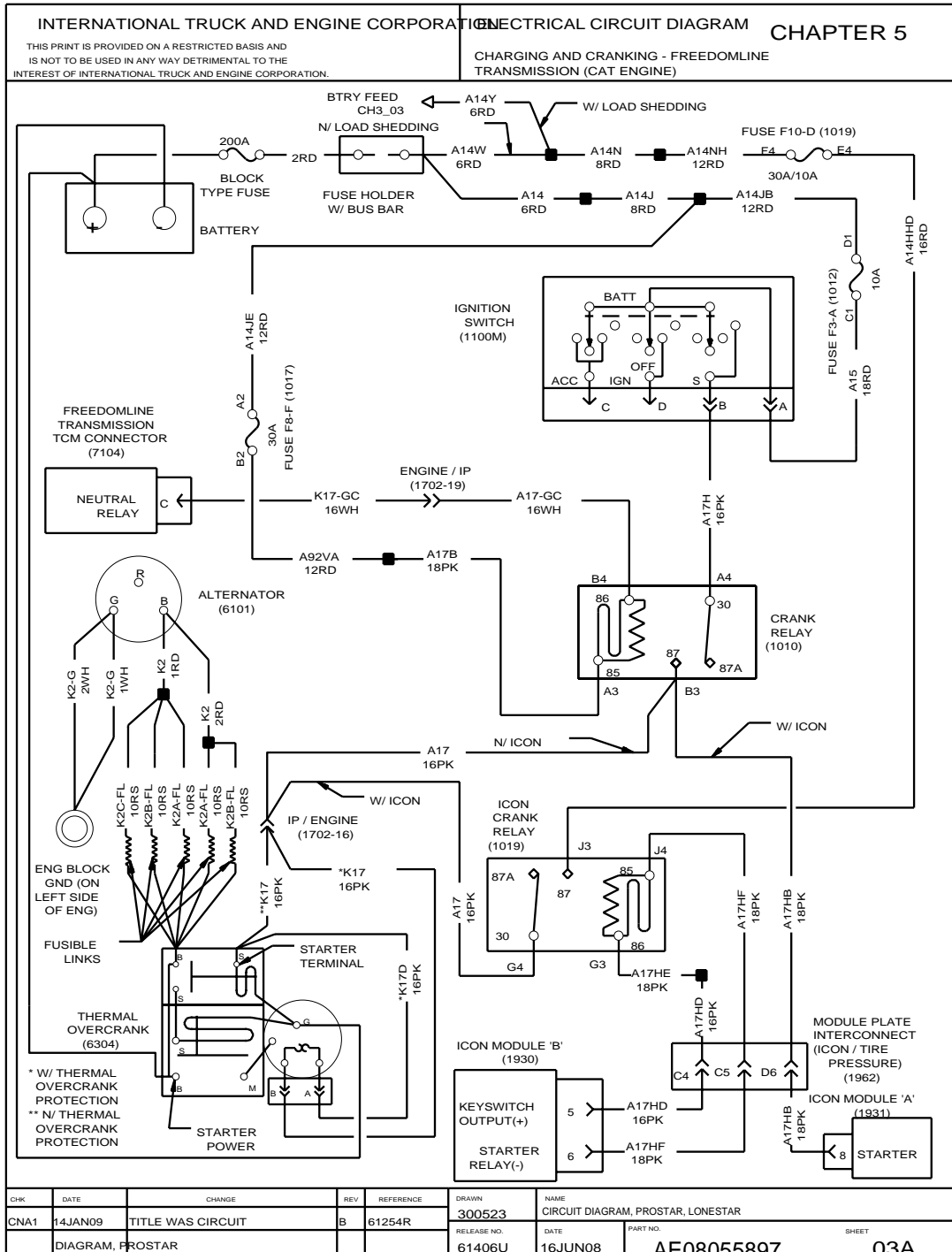


Figure 107 Freedomline Transmission (Cat Engine)

6. ETHER START AND FAN WIRING (CHAPTER 6)

6.1. ETHER START CUMMINS ISX, P. 1

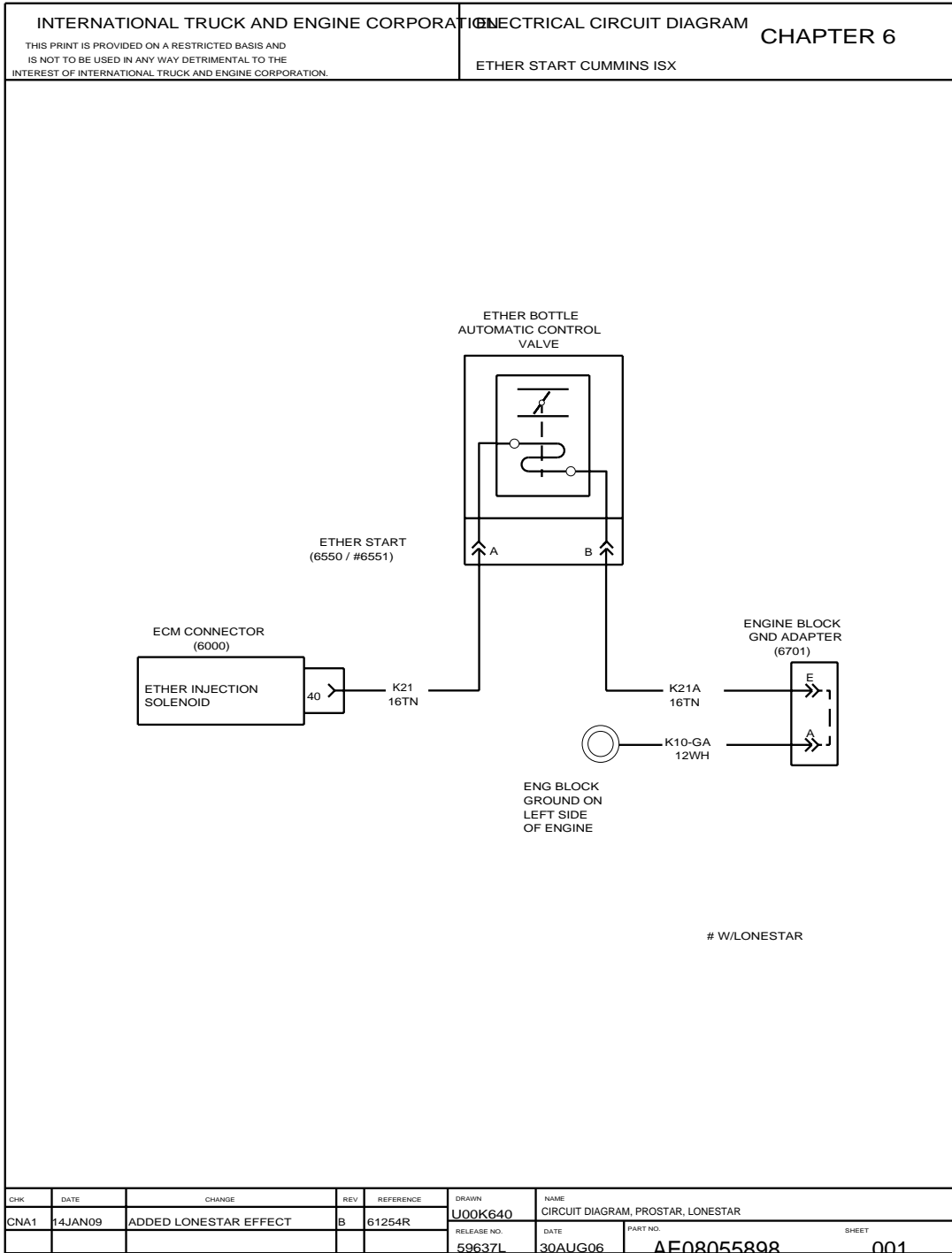


Figure 108 Ether Start Cummins ISX

6.2. FAN WIRING, P. 2

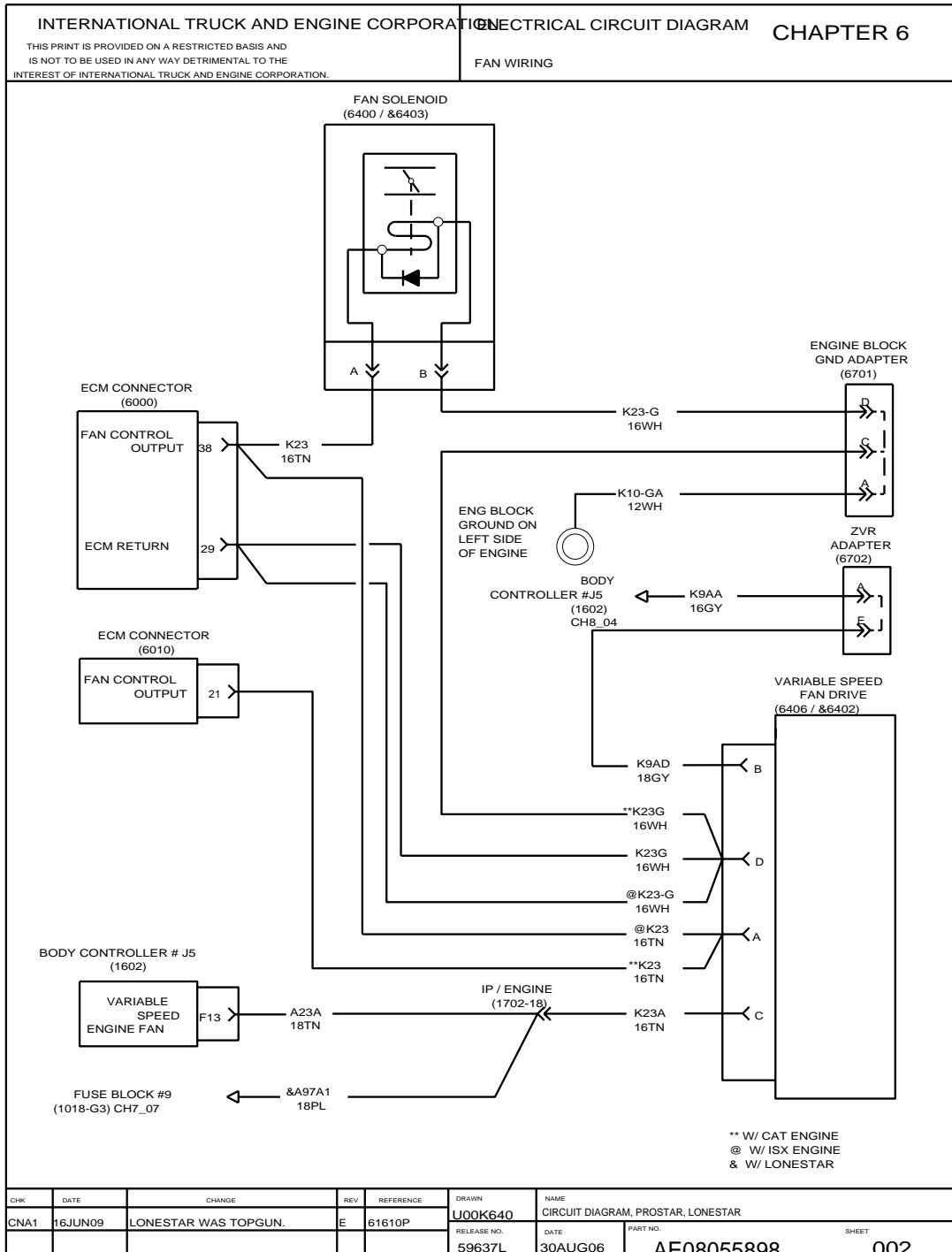


Figure 109 Fan Wiring

6.3. FAN WIRING — IBB ENGINE, P. 3

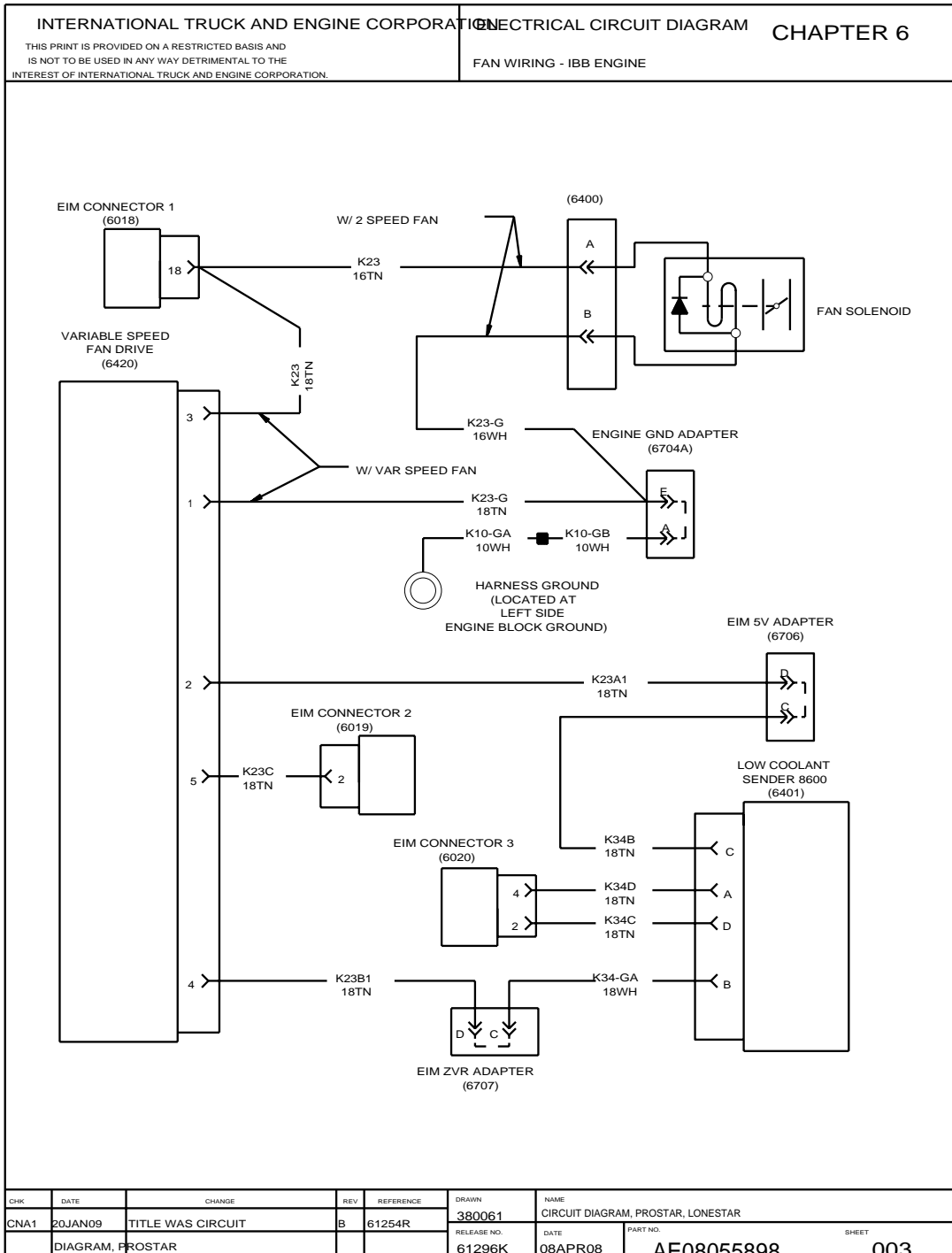


Figure 110 Fan Wiring — IBB Engine

6.4. STARTING AID — COLD START ASSIST (IBB ENGINE), P. 4

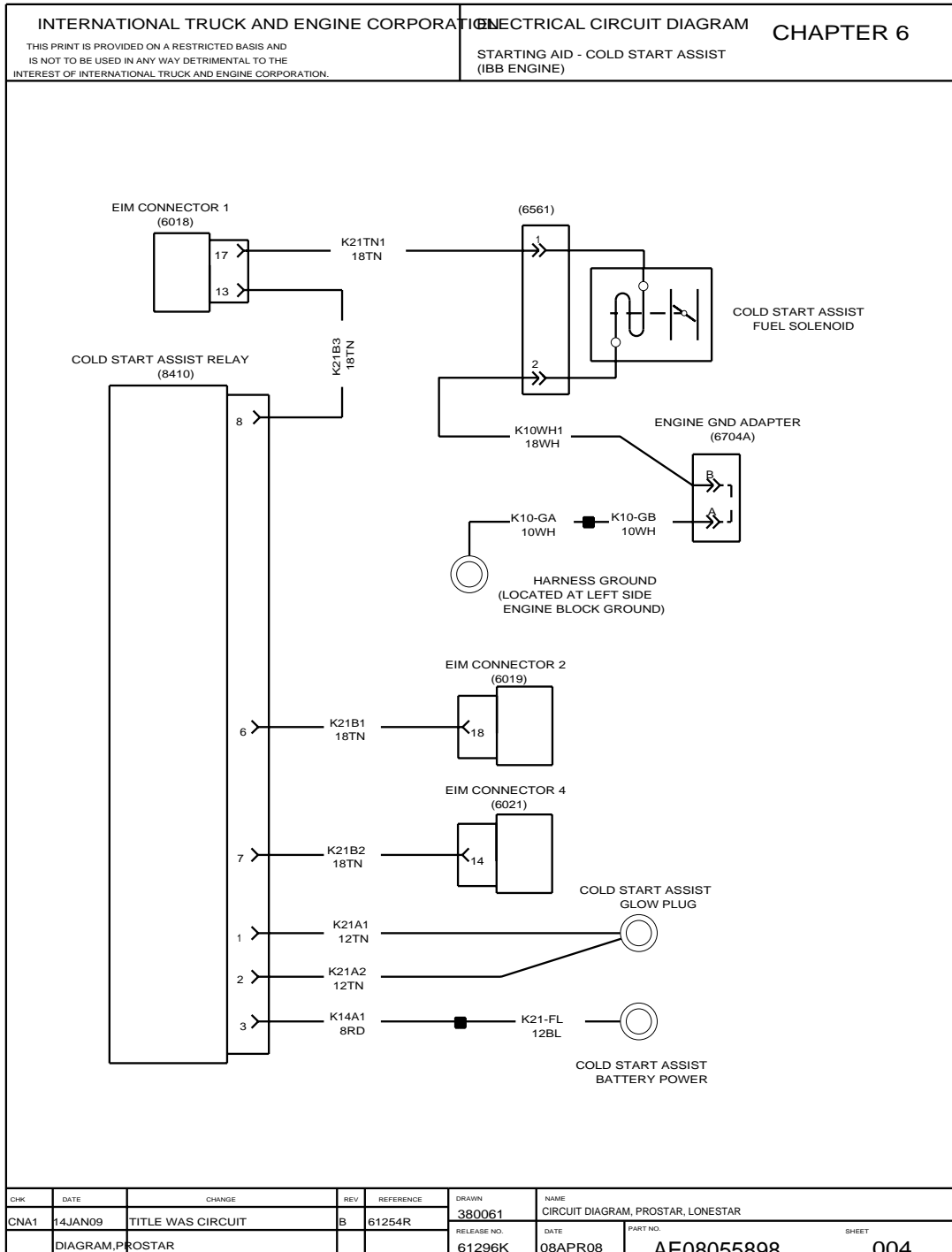


Figure 111 Starting Aid — Cold Start Assist (IBB Engine)

7. ENGINES (CHAPTER 7)

7.1. ELECTRONIC ENGINE CONTROLS, P. 1

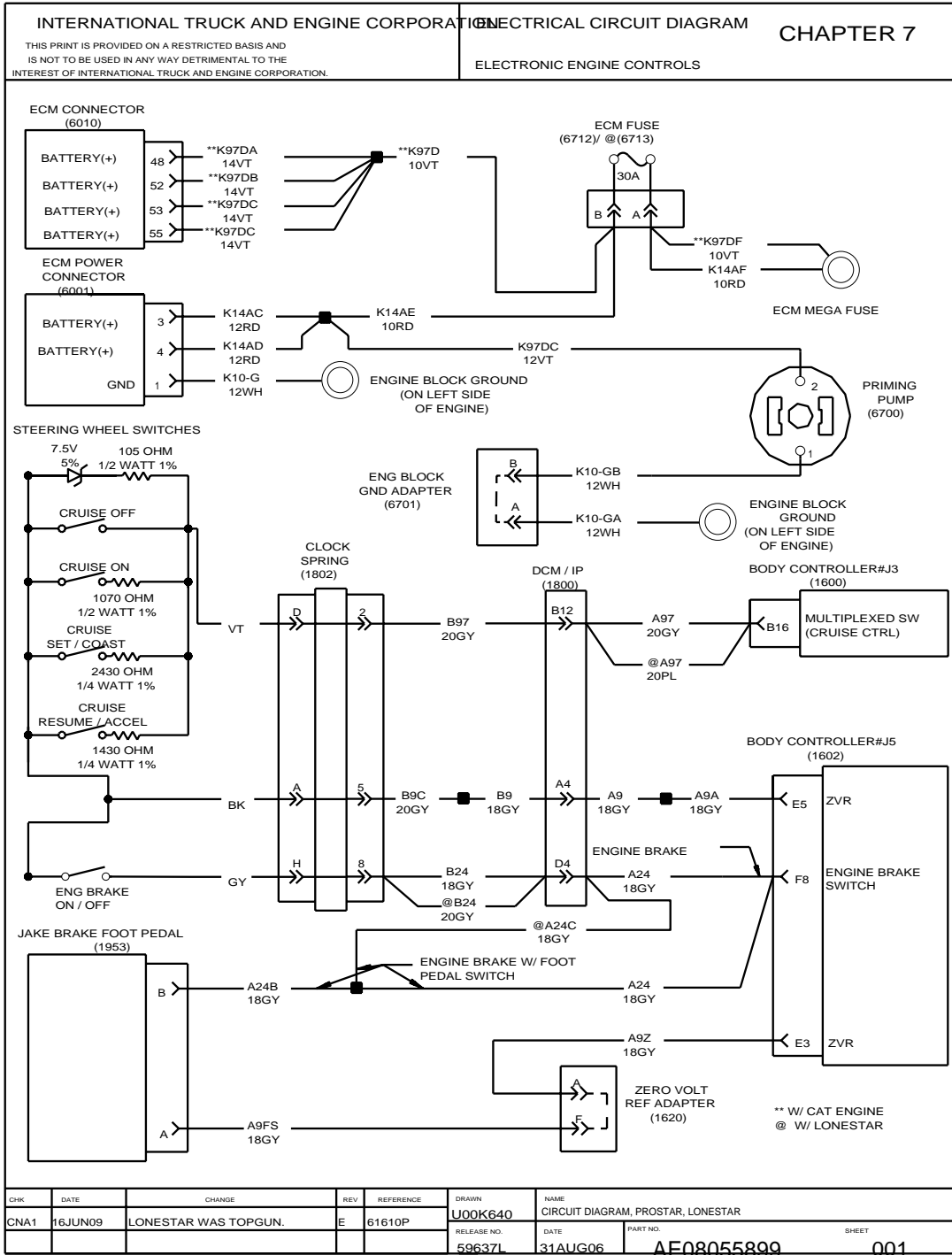


Figure 112 Electronic Engine Controls

7.2. ELECTRONIC ENGINE CONTROLS — CUMMINS ENGINE, P. 2

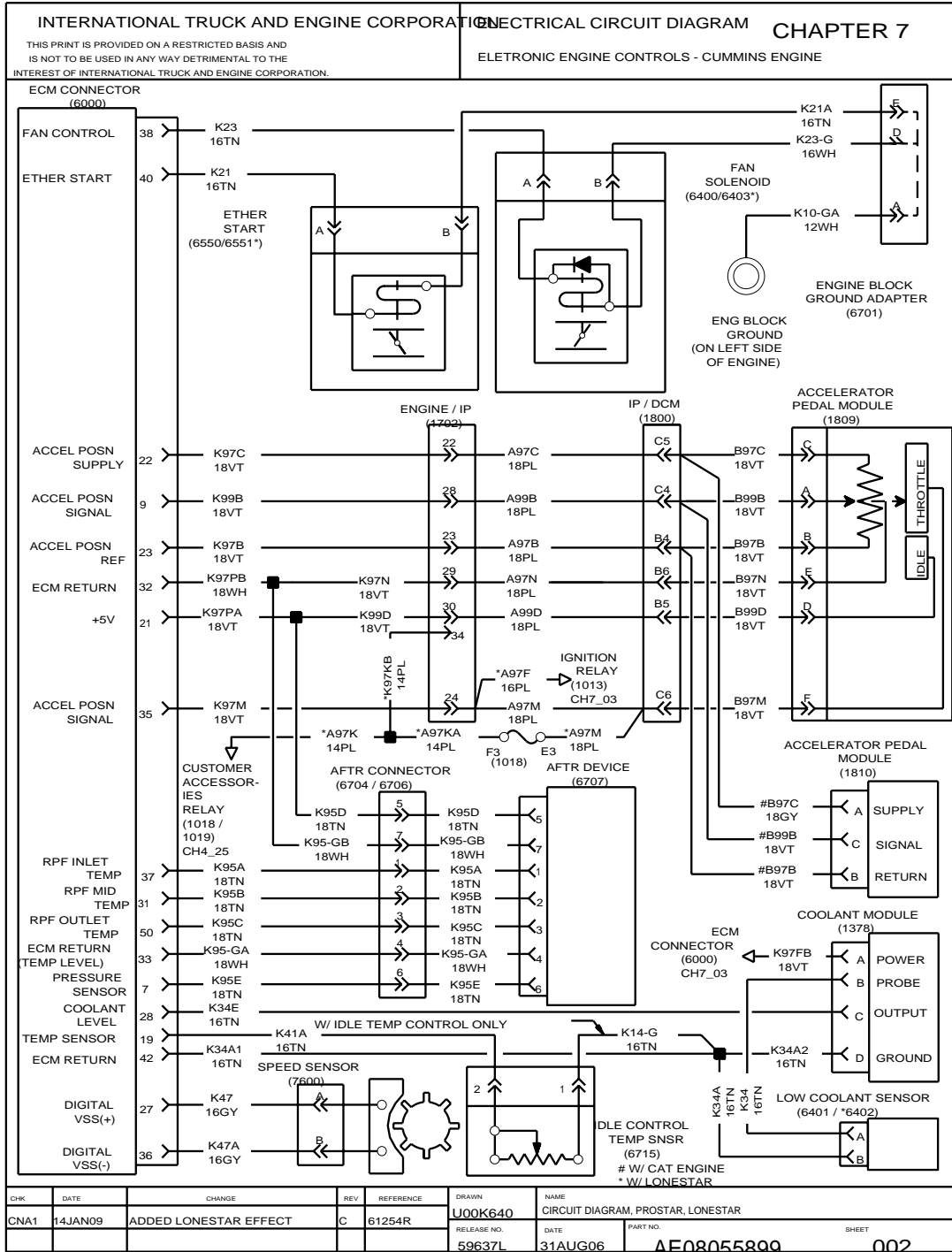


Figure 113 Electronic Engine Controls — Cummins Engine

7.3. ELECTRONIC ENGINE CONTROLS — CAT ENGINE, P. 2A

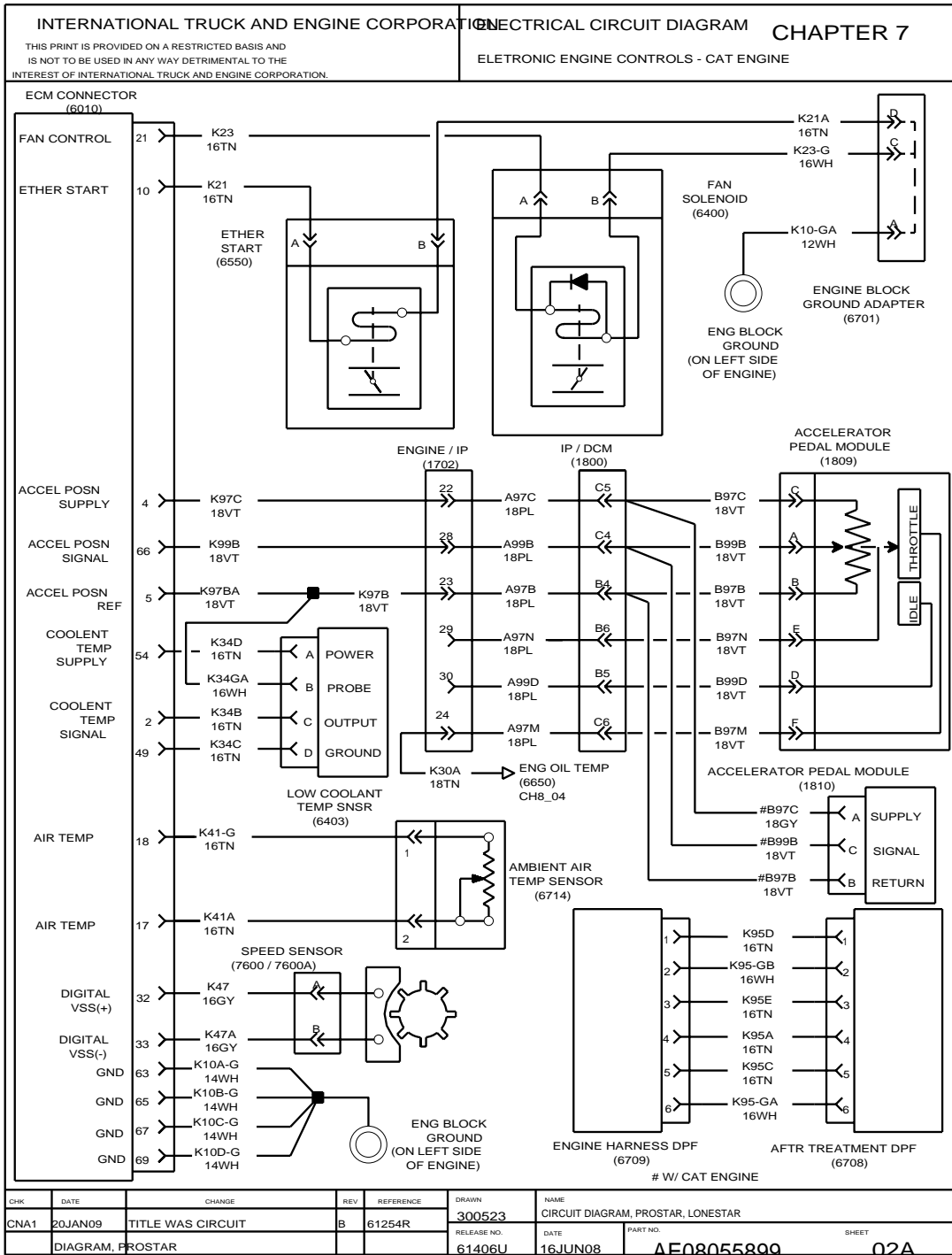


Figure 114 Electronic Engine Controls — Cat Engine

7.4. ELECTRONIC ENGINE CONTROLS — CUMMINS ENGINES, P. 3

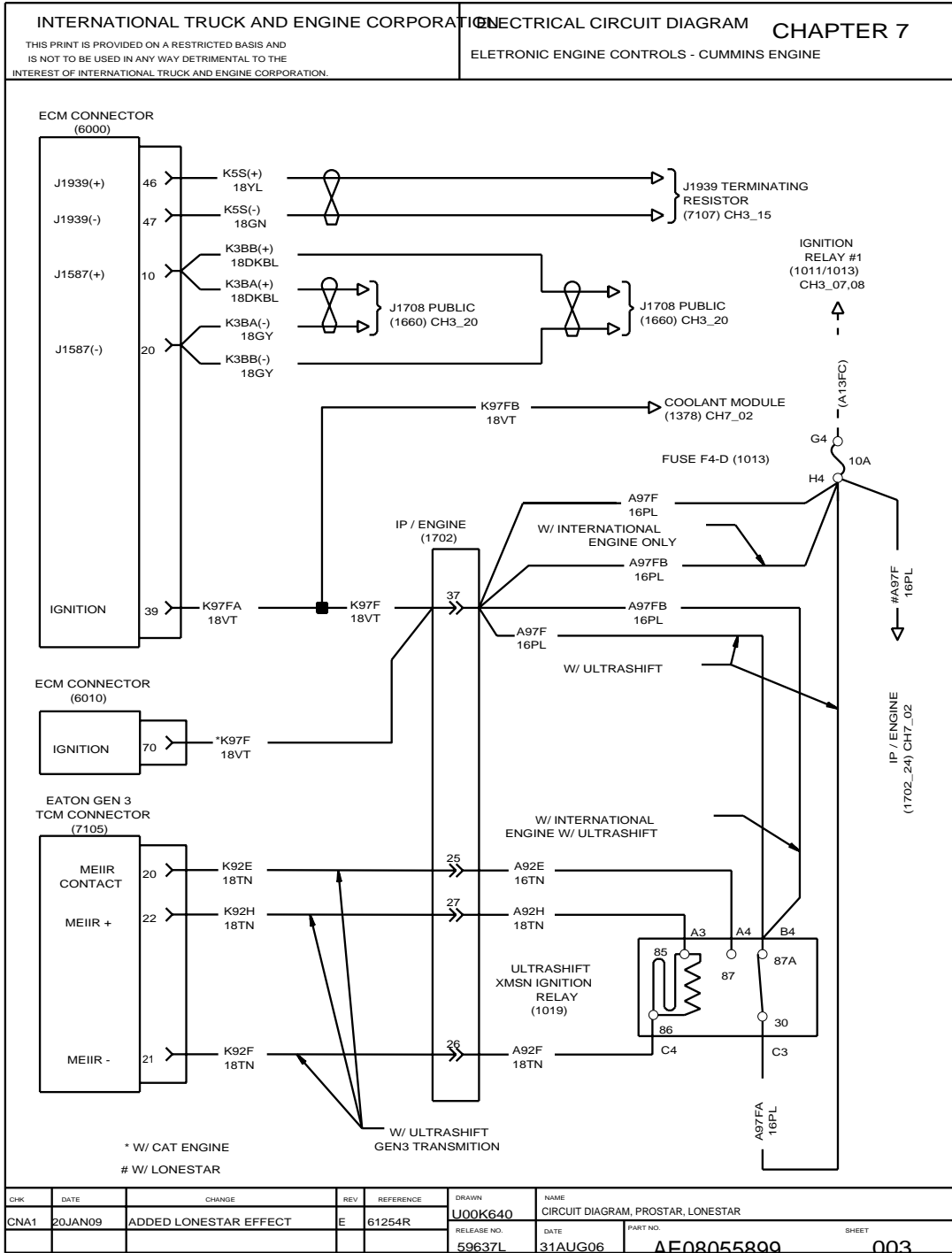


Figure 115 Electronic Engine Controls — Cummins Engines

7.5. ELECTRONIC ENGINE CONTROLS WITH ICON, P. 4

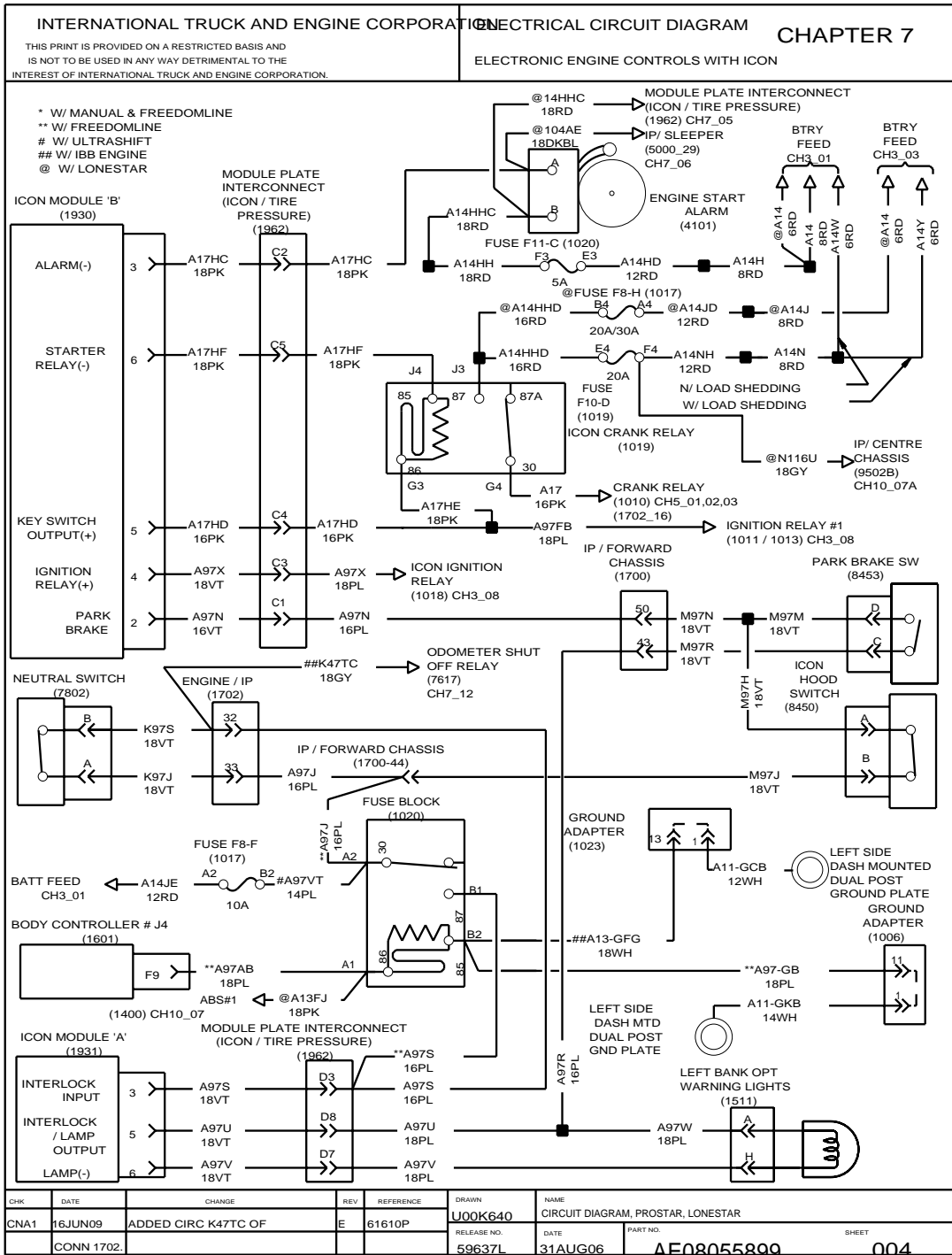


Figure 116 Electronic Engine Controls with ICON

7.6. ELECTRONIC ENGINE CONTROLS WITH ICON, P. 5

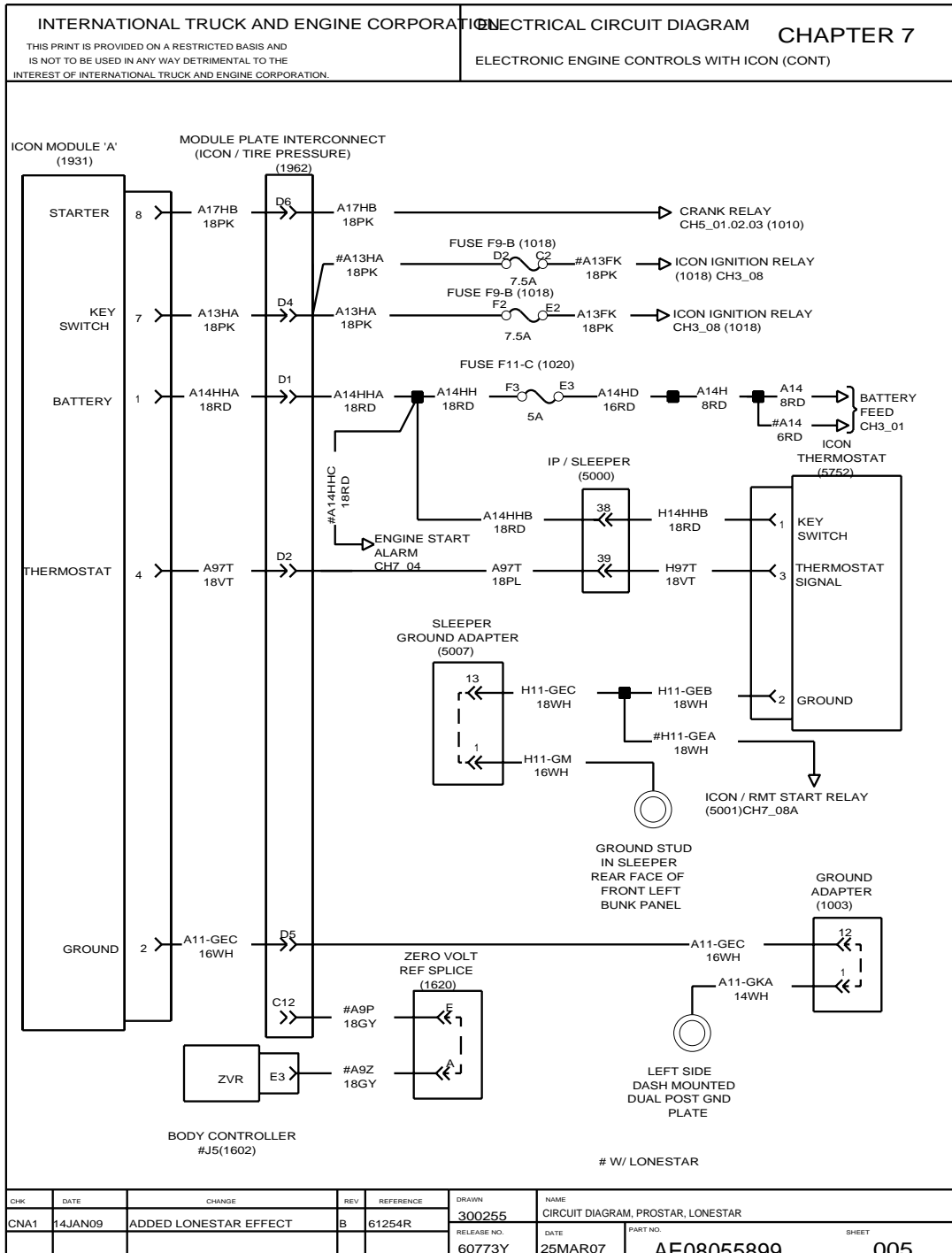


Figure 117 Electronic Engine Controls with ICON (Cont.)

7.7. ELECTRONIC ENGINE CONTROLS WITH ICON, P. 6

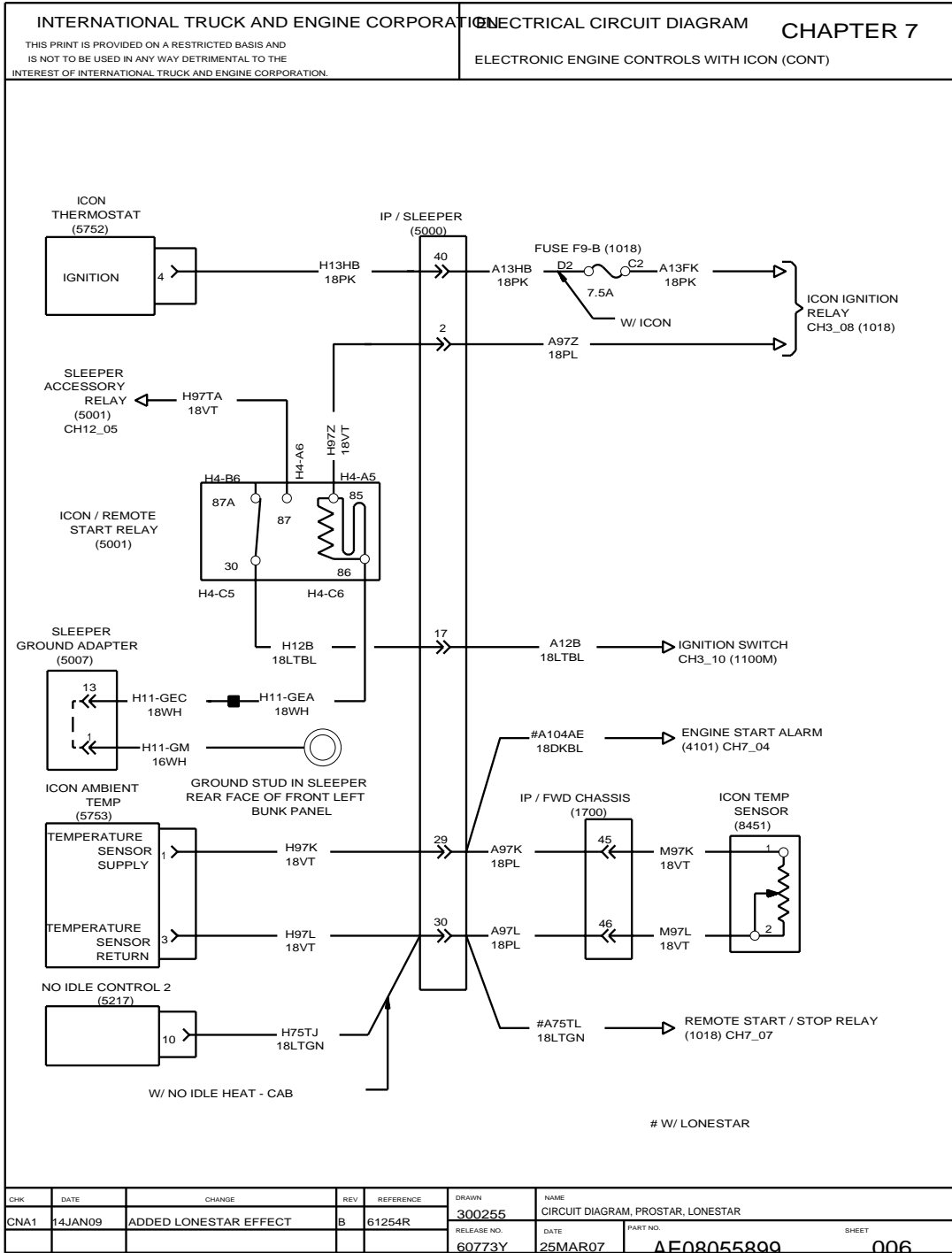


Figure 118 Electronic Engine Controls with ICON (Cont.)

7.8. REMOTE START/STOP, P. 7

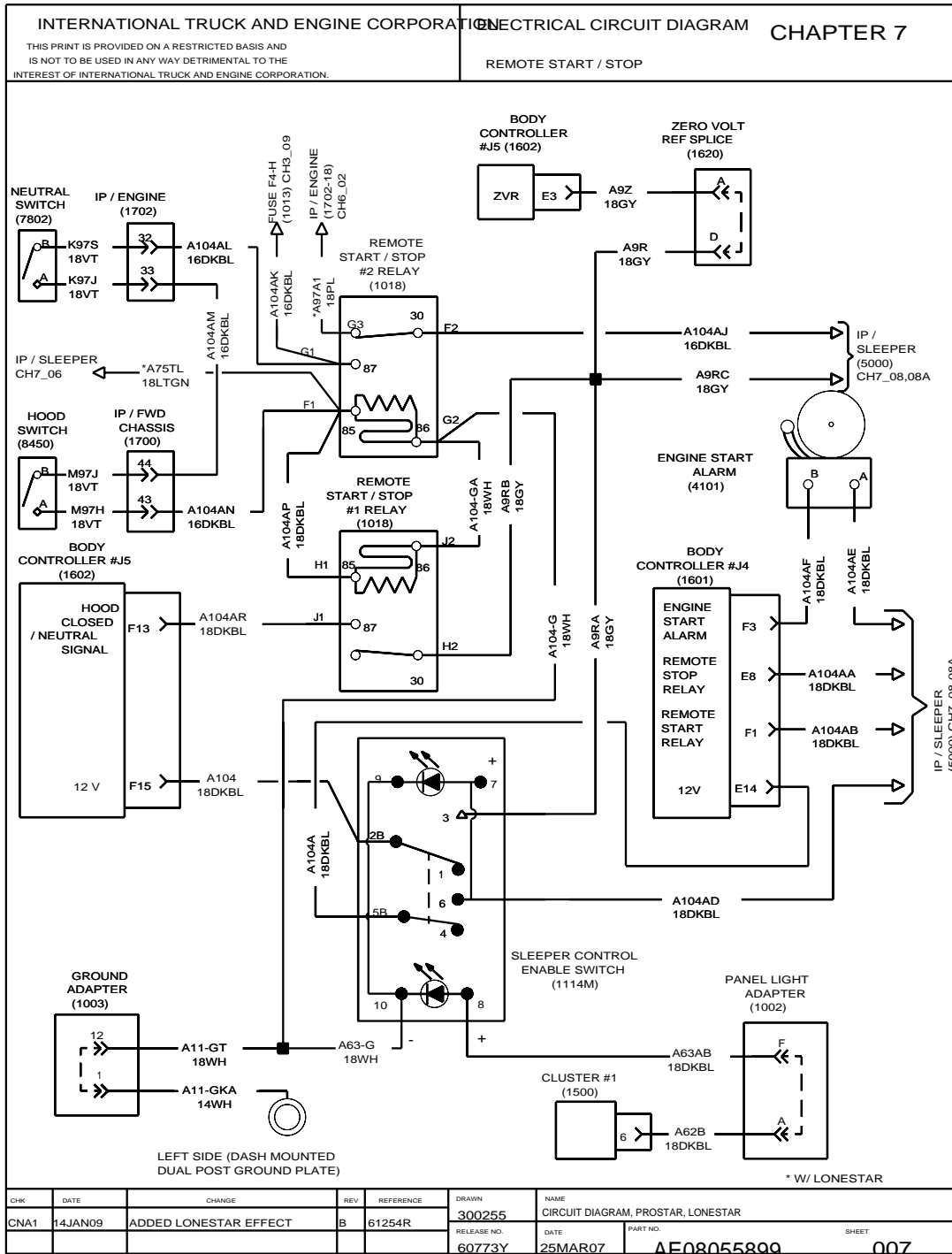


Figure 119 Remote Start/Stop

7.9. REMOTE START/STOP, P. 8

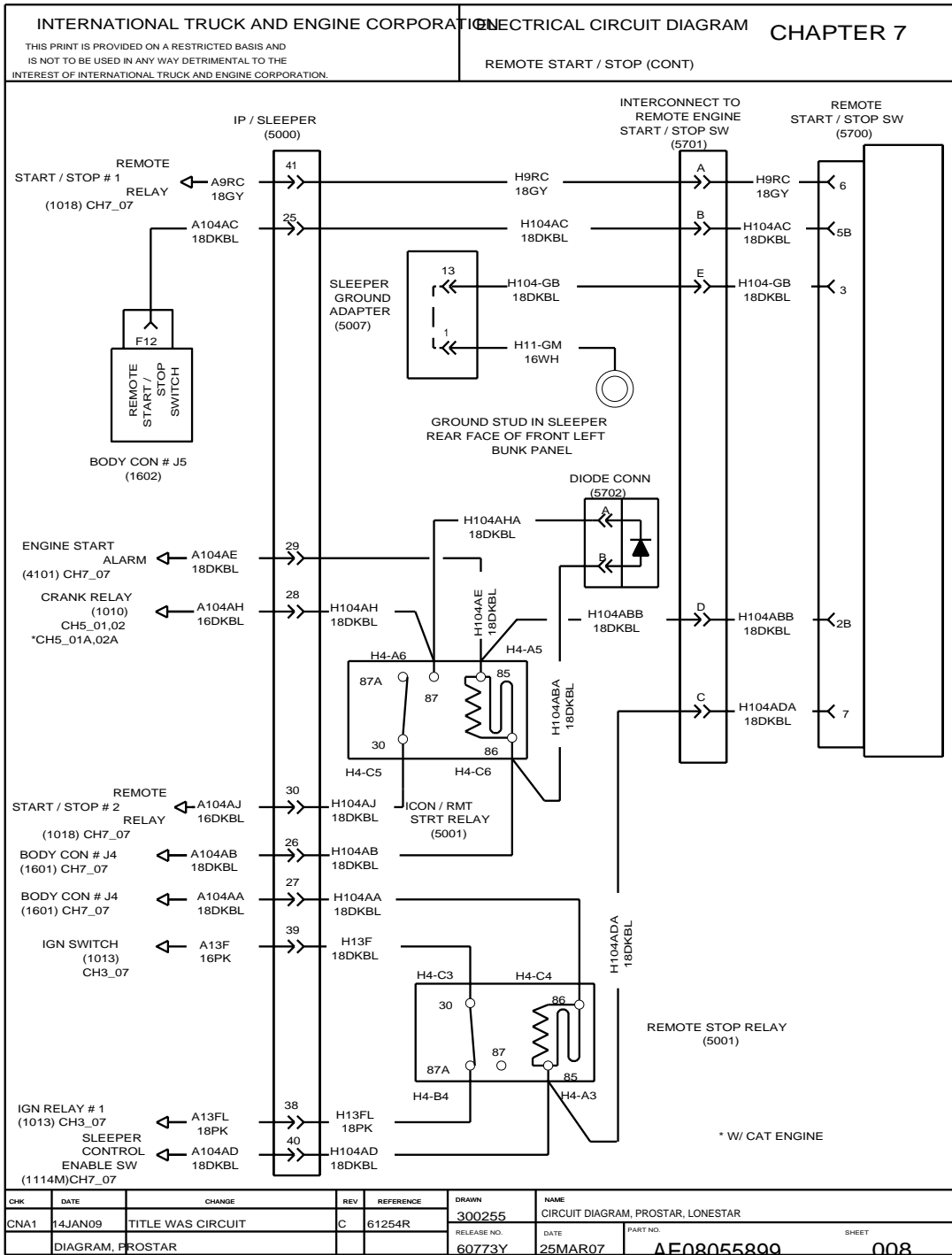


Figure 120 Remote Start/Stop (Cont.)

7.10. REMOTE START/STOP, P. 8A

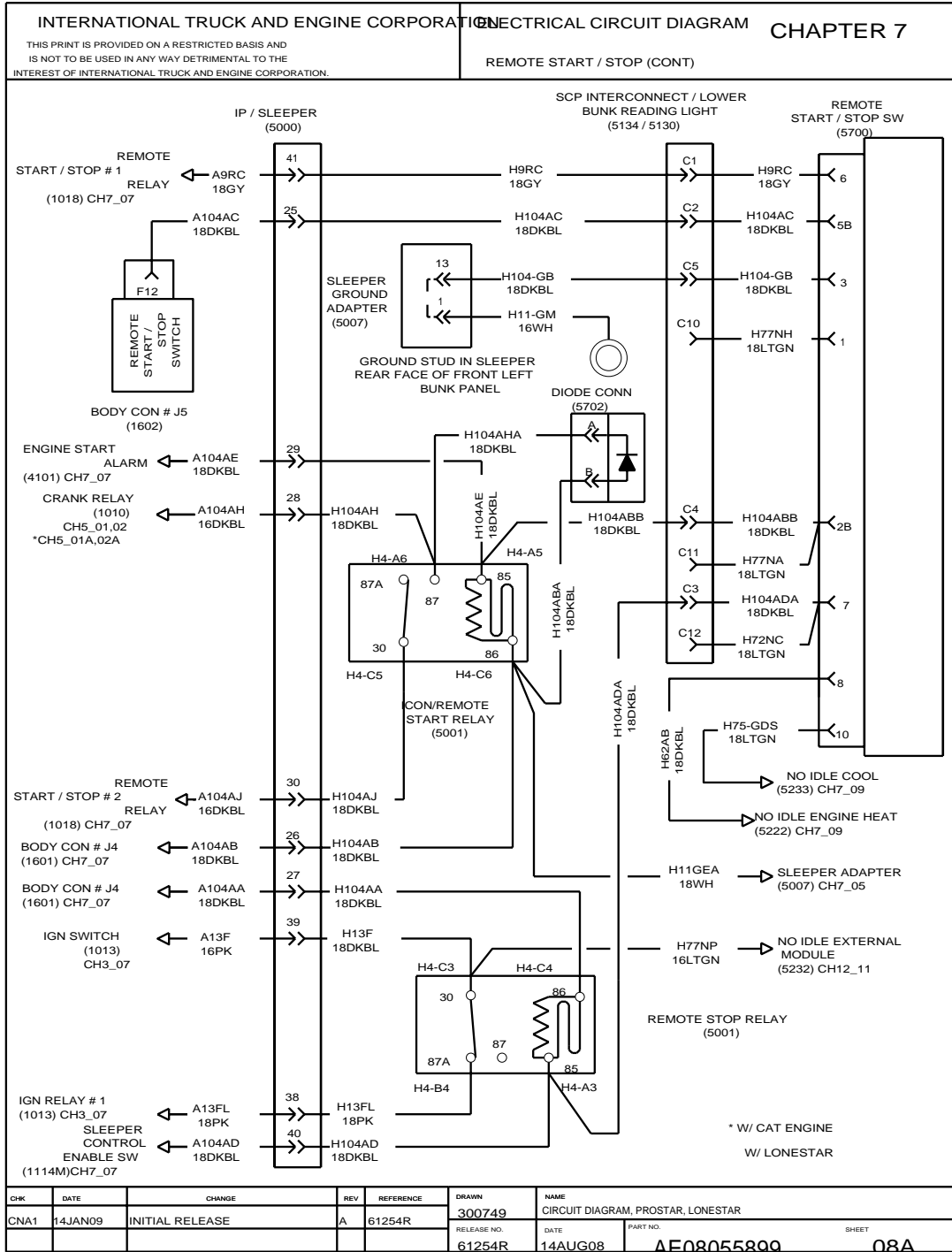


Figure 121 Remote Start/Stop (Cont.)

7.11. NO IDLE ENGINE HEAT, P. 9

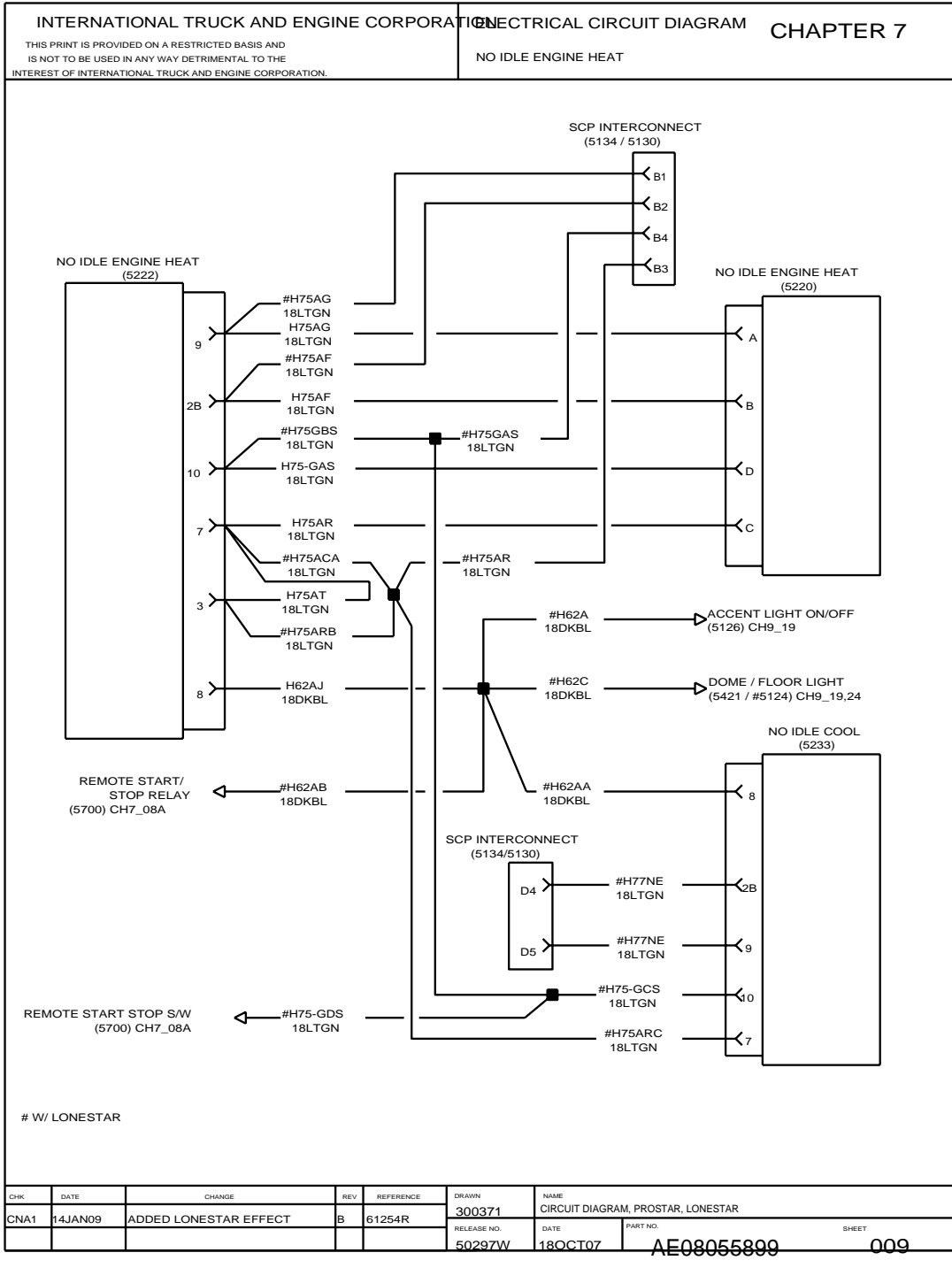


Figure 122 No Idle Engine Heat

7.12. TRI-PAC NO IDLE, P. 10

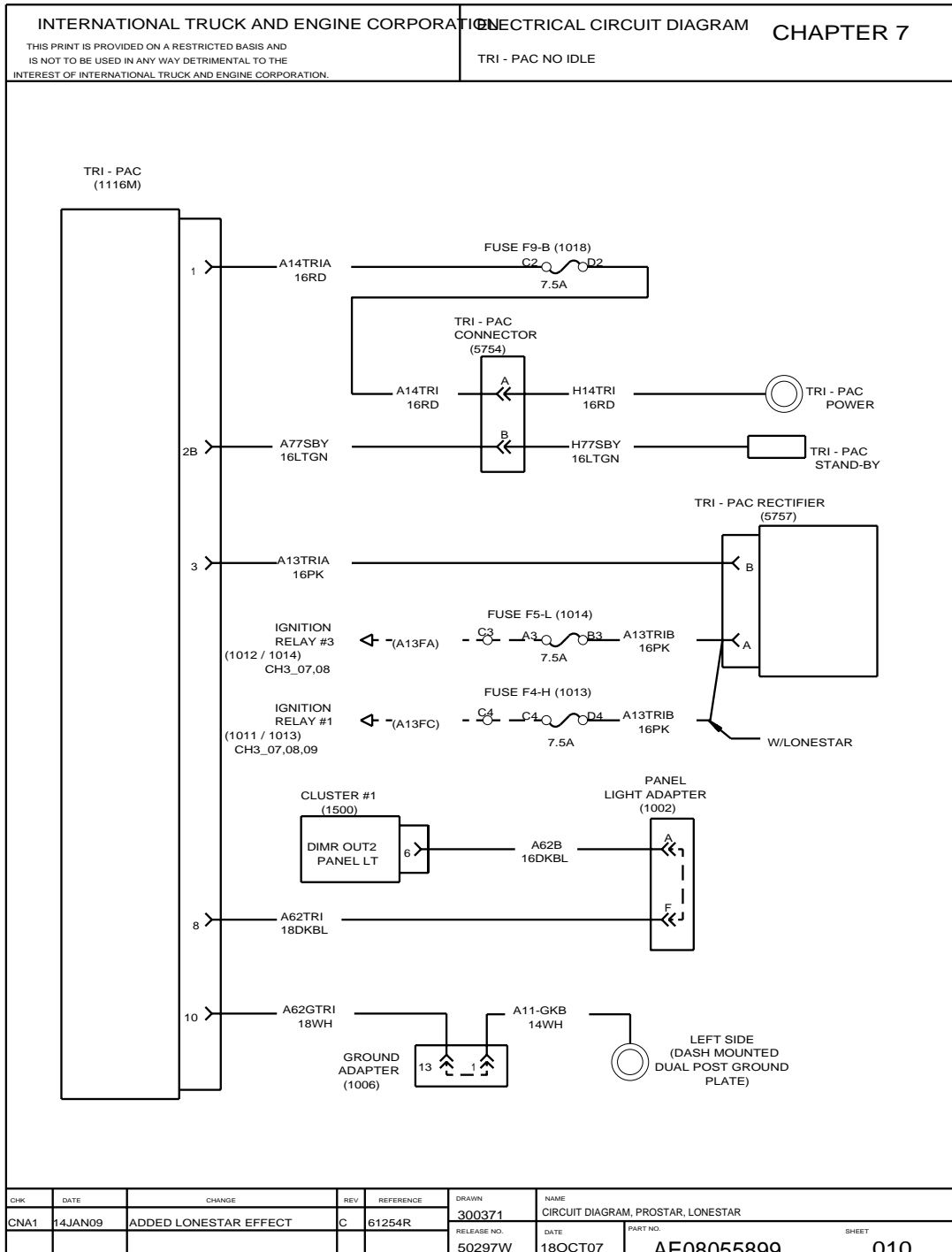


Figure 123 Tri-Pac No Idle

7.13. ELECTRONIC ENGINE CONTROLS (IBB ENGINE), P. 11

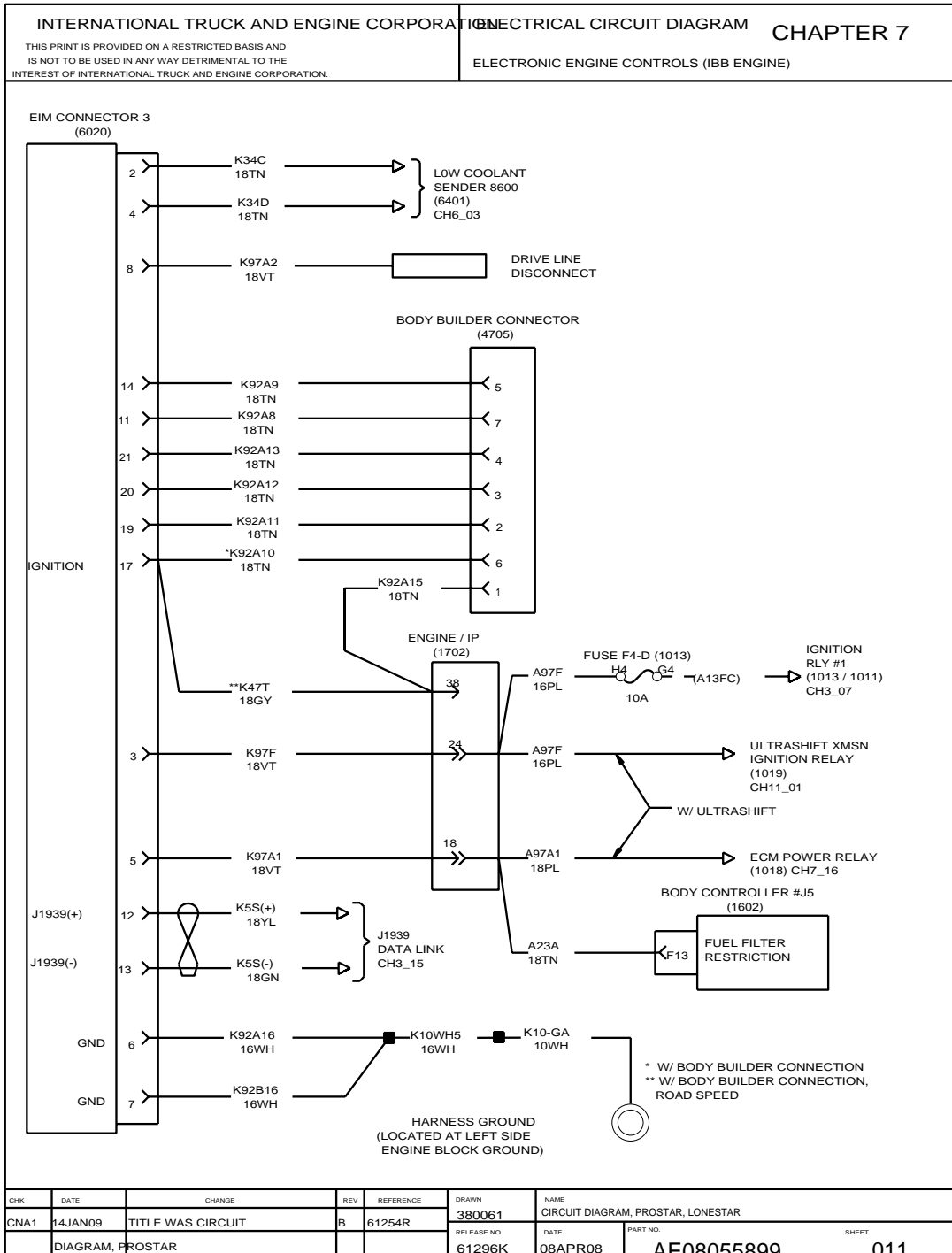


Figure 124 Electronic Engine Controls (IBB Engine)

7.14. ELECTRONIC ENGINE CONTROLS (IBB ENGINE), P. 12

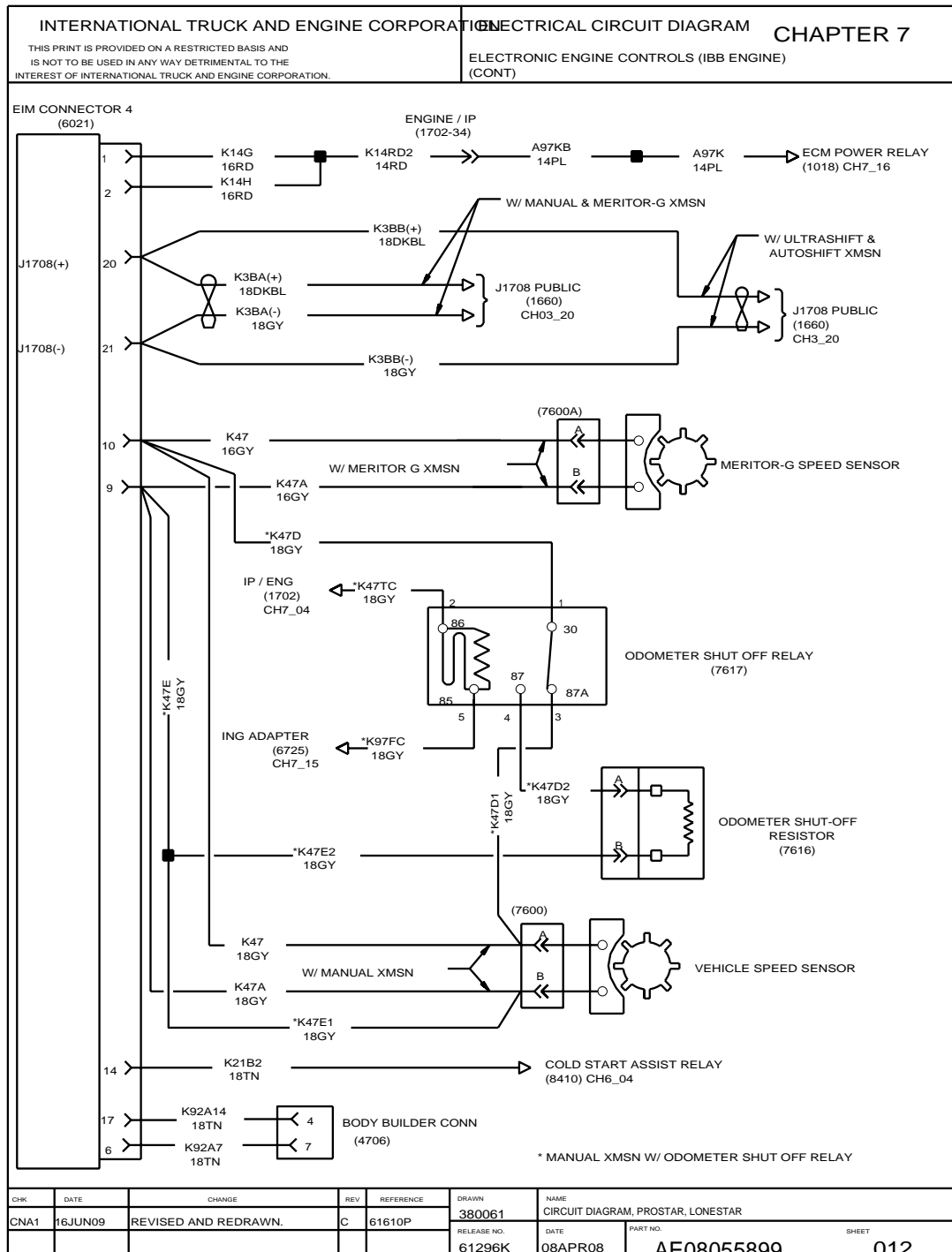


Figure 125 Electronic Engine Controls (IBB Engine)

7.15. ELECTRONIC ENGINE CONTROLS (IBB ENGINE), P. 12A

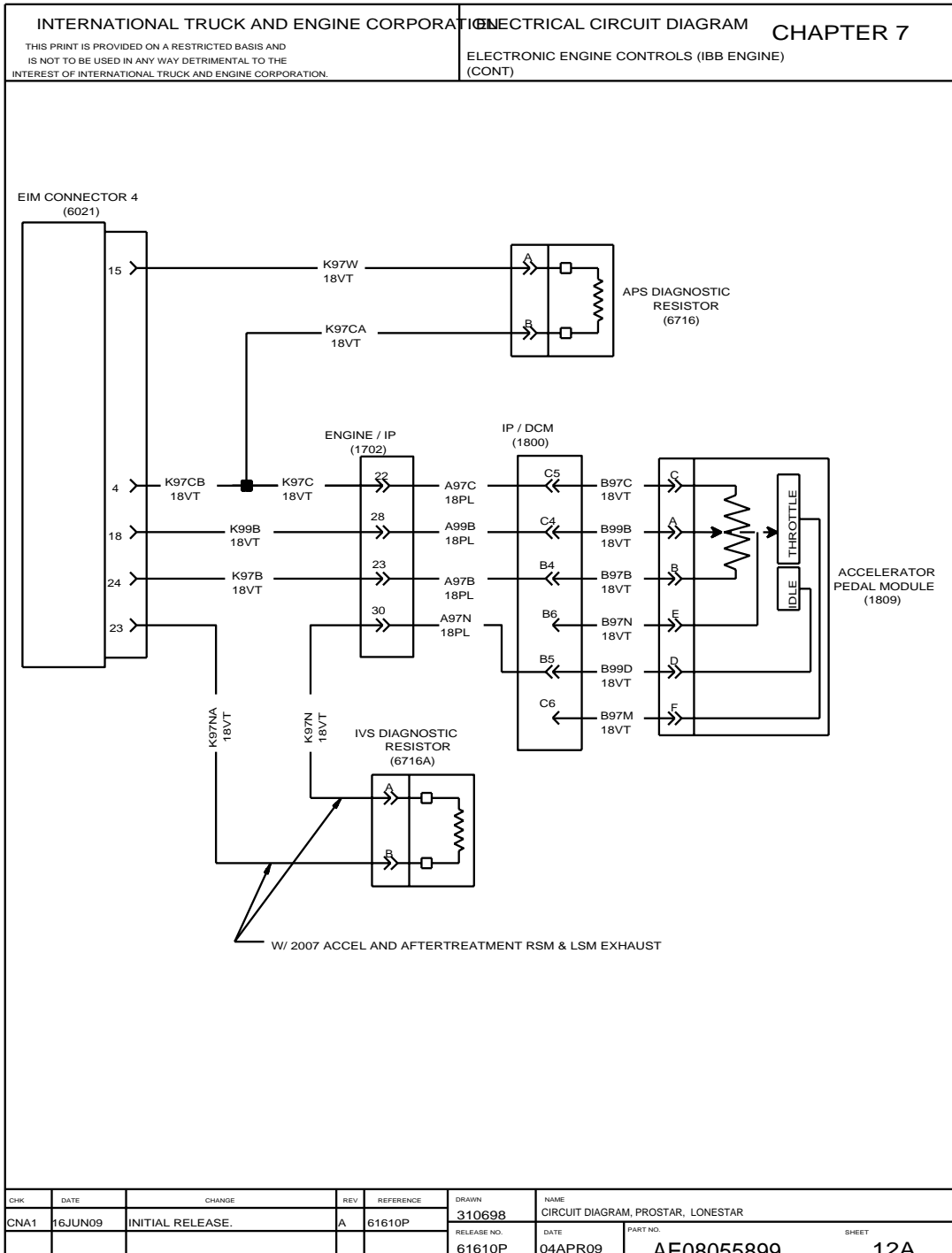


Figure 126 Electronic Engine Controls (IBB Engine)

7.16. ELECTRONIC ENGINE CONTROLS (IBB ENGINE), P. 13

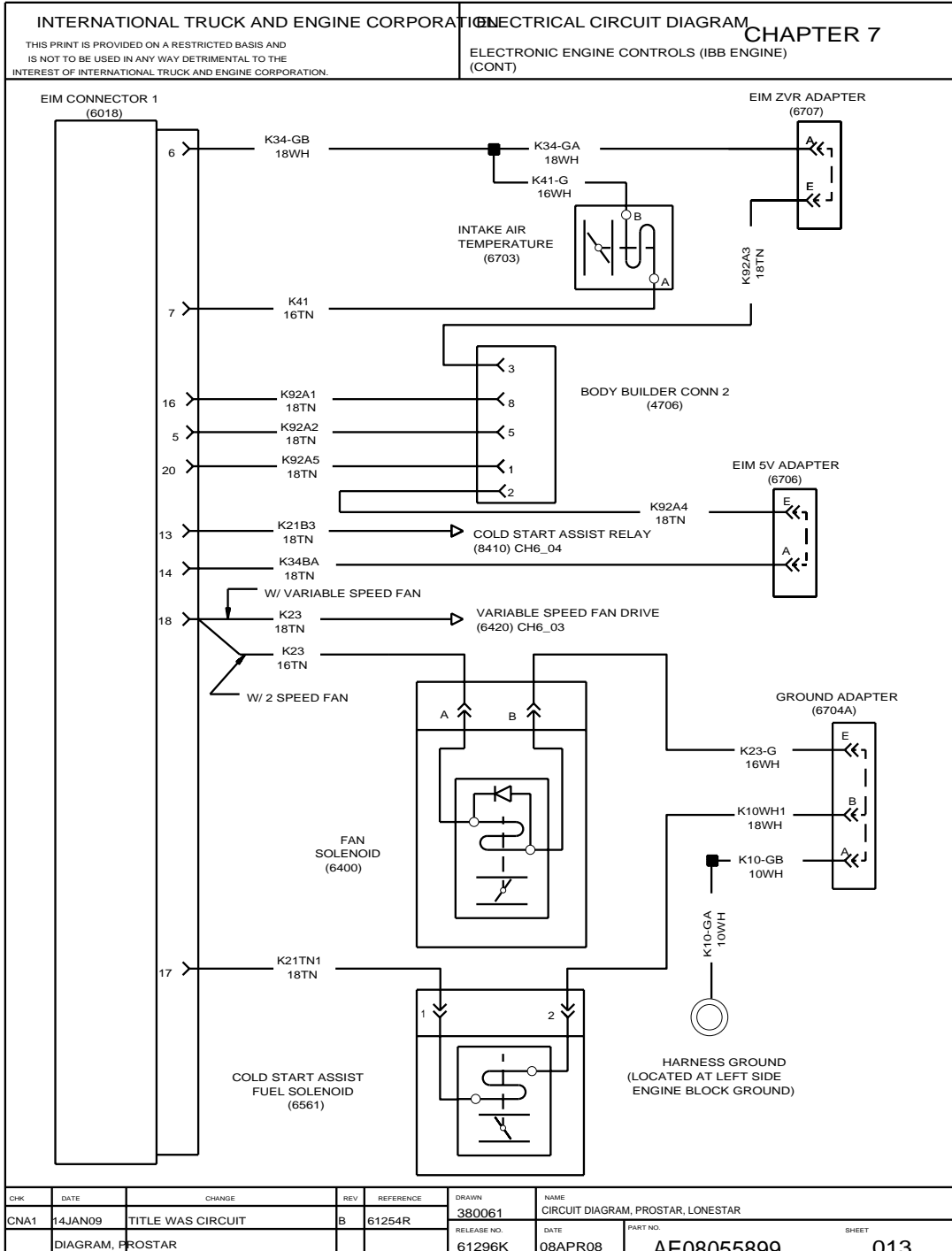


Figure 127 Electronic Engine Controls (IBB Engine)

7.17. ELECTRONIC ENGINE CONTROLS (IBB ENGINE), P. 14

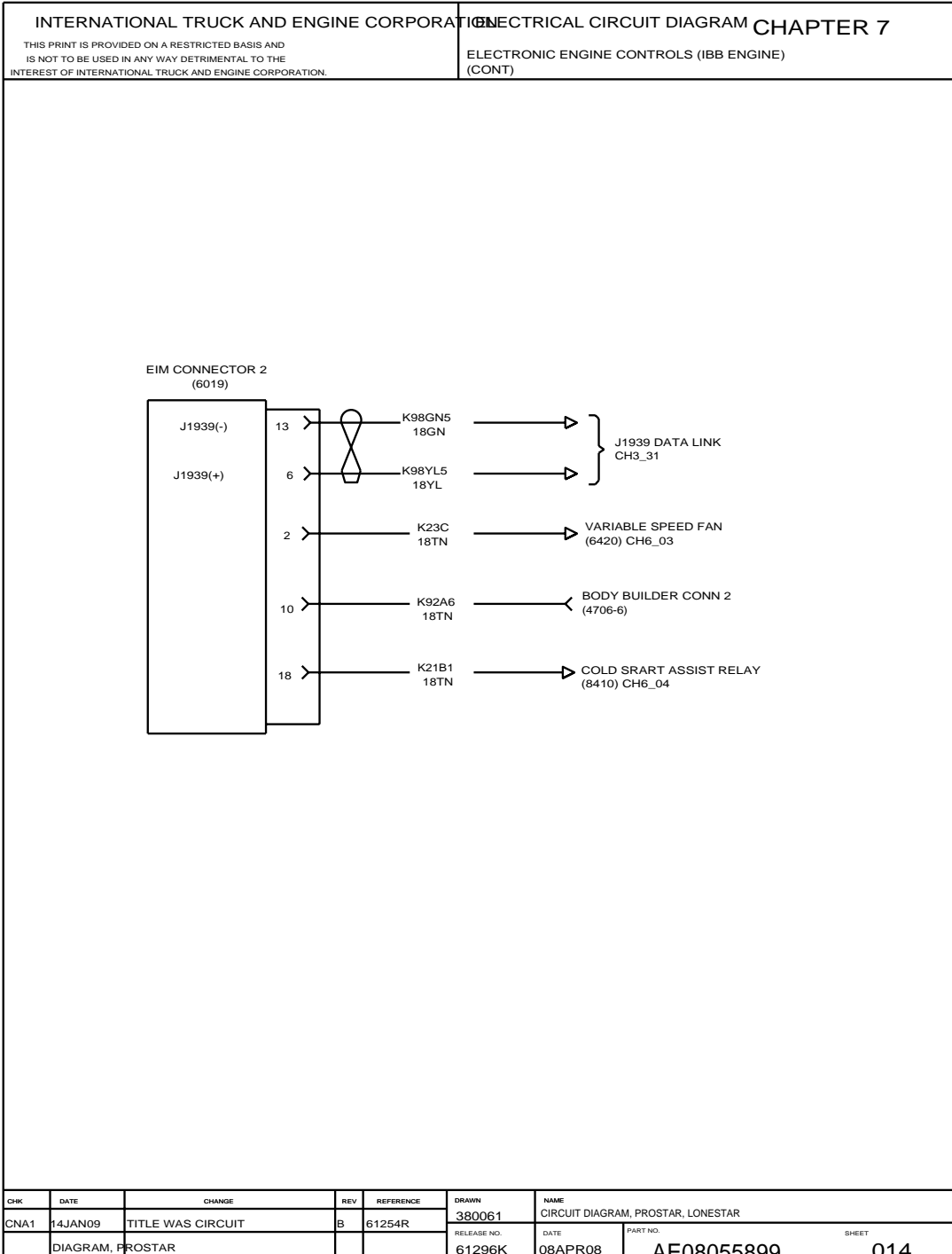


Figure 128 Electronic Engine Controls (IBB Engine)

7.18. ELECTRONIC ENGINE CONTROLS (IBB ENGINE), P. 15

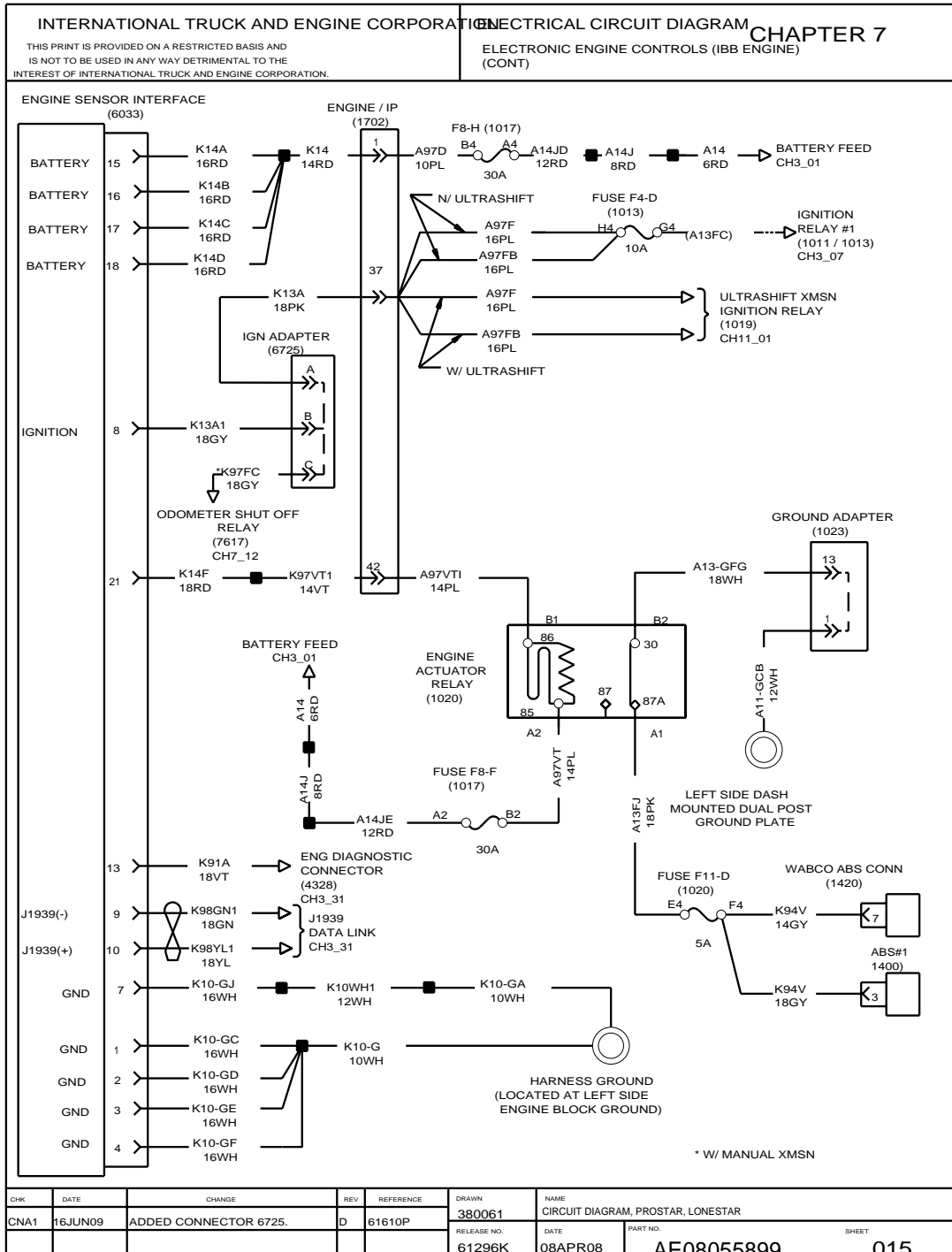


Figure 129 Electronic Engine Controls (IBB Engine)

7.19. AFTERTREATMENT (IBB ENGINE), P. 16

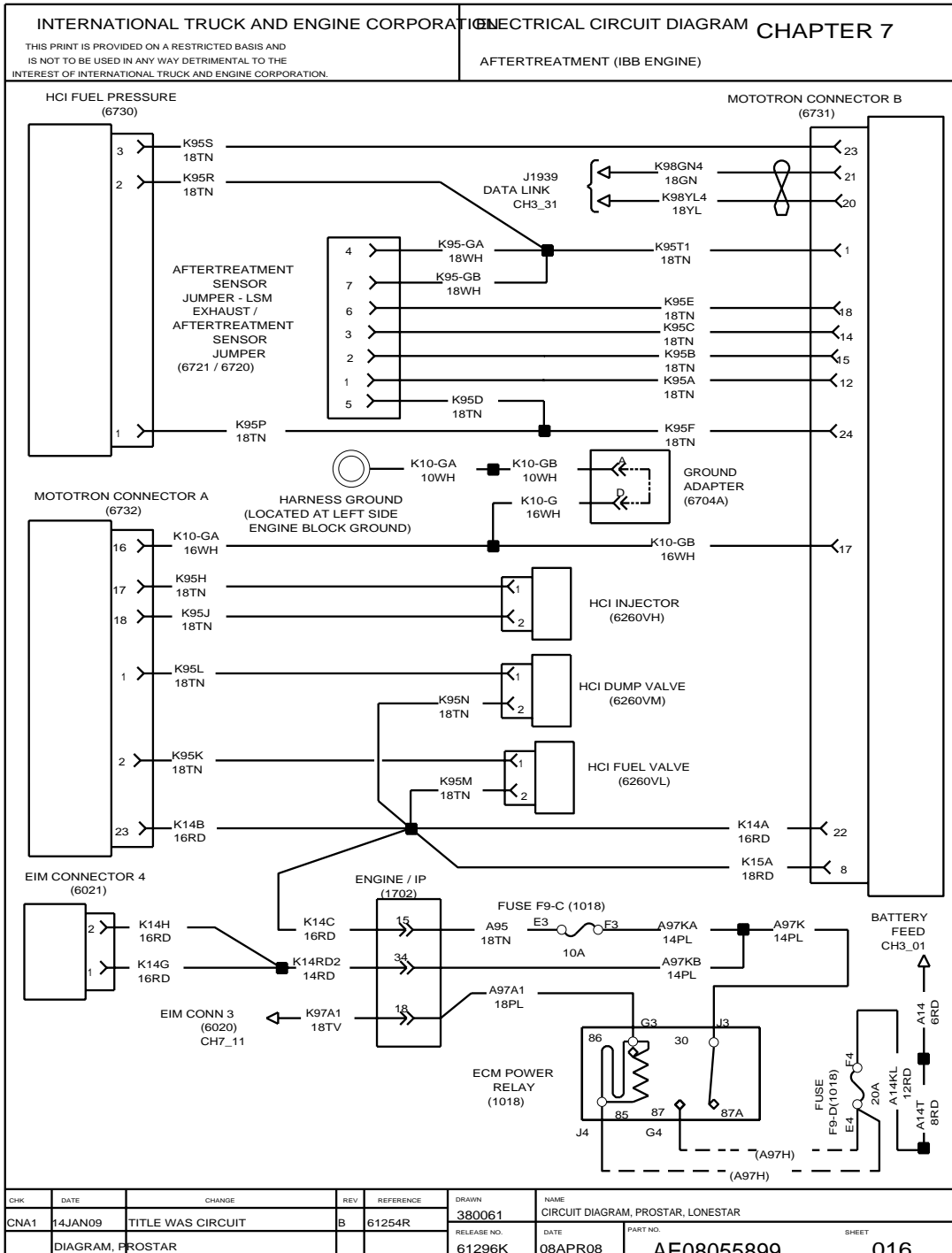


Figure 130 Aftertreatment (IBB Engine)

## 8. GAUGES AND WARNING LIGHTS (CHAPTER 8)

### 8.1. AIR PRESSURE INPUT CIRCUIT AND AIR RESTRICTION GAUGE, P. 1

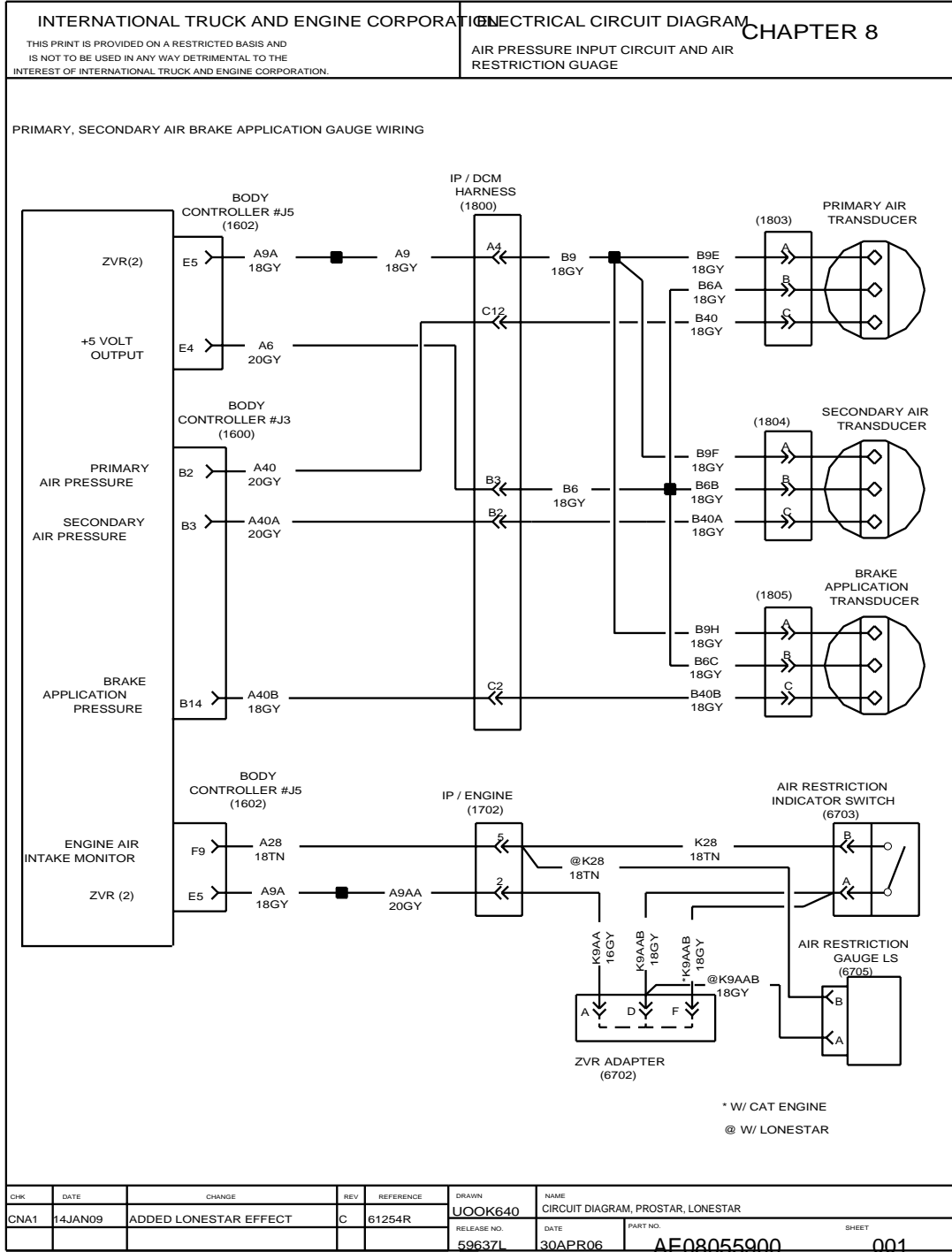


Figure 131 Air Pressure Input Circuit and Air Restriction Gauge

8.2. AXLE TEMPERATURE GAUGES, P. 2

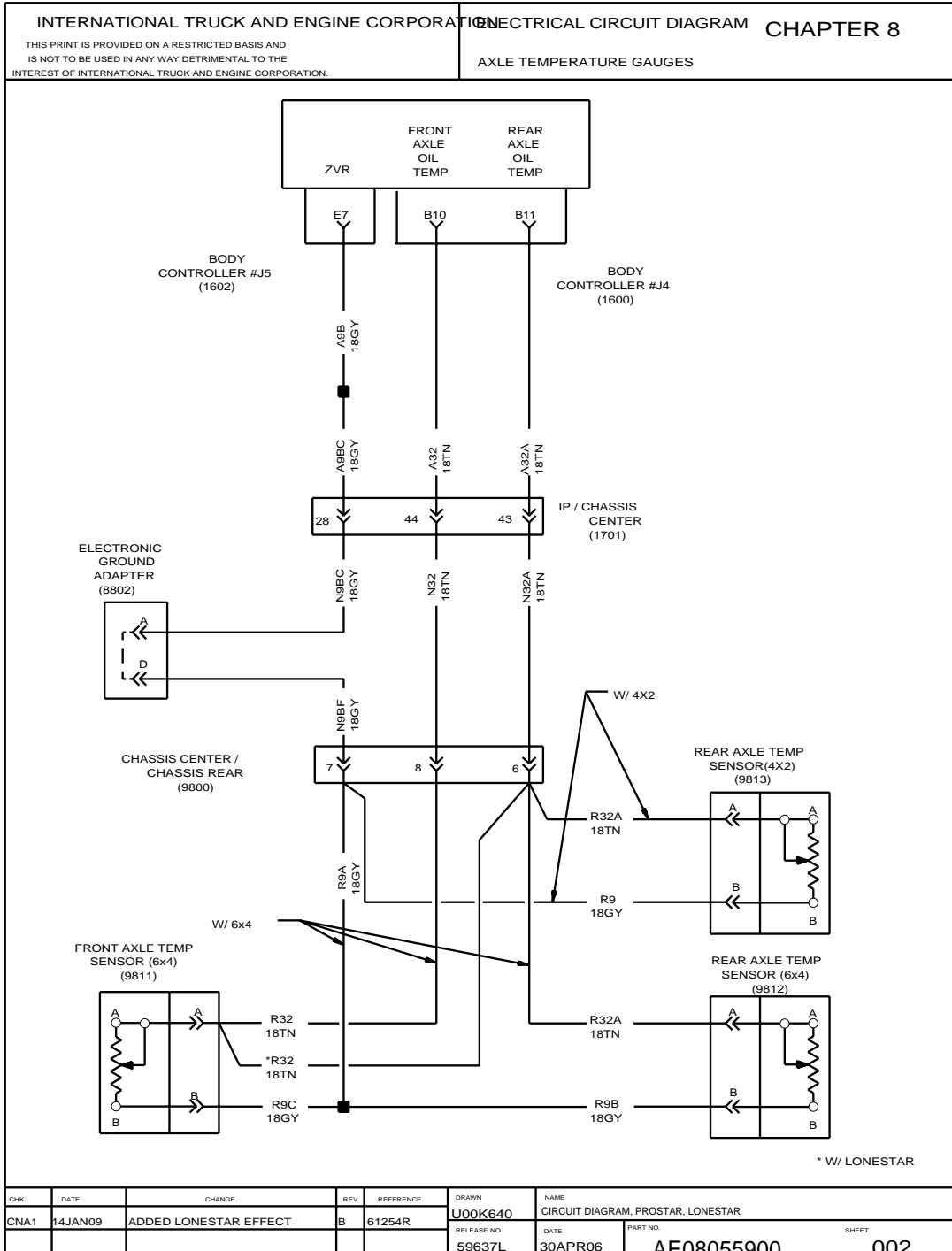


Figure 132 Axle Temperature Gauges

**8.3. ENGINE OIL PRESSURE AND TEMPERATURE, SPEEDOMETER, TACHOMETER, VOLTMETER AND WATER TEMP. GAUGES, P. 3**

INTERNATIONAL TRUCK AND ENGINE CORPORATION				ELECTRICAL CIRCUIT DIAGRAM CHAPTER 8			
THIS PRINT IS PROVIDED ON A RESTRICTED BASIS AND IS NOT TO BE USED IN ANY WAY DETRIMENTAL TO THE INTEREST OF INTERNATIONAL TRUCK AND ENGINE CORPORATION.				ENGINE OIL PRESSURE AND TEMP, SPEEDO, TACHO, VOLTMETER AND WATER TEMP GAUGE			
<p>REFER TO CONSOLIDATED ENGINE / VEHICLE CONTROLLER DIAGNOSTICS MANUAL FOR CIRCUIT DIAGRAMS SHOWING INPUT CIRCUITRY FOR THE FOLLOWING DATALINK DRIVEN SYSTEM:</p> <p>ENGINE OIL PRESSURE GAUGE</p> <p>ENGINE OIL TEMPERATURE GAUGE</p> <p>SPEEDOMETER GAUGE</p> <p>TACHOMETER GAUGE</p> <p>WATER TEMPERATURE GAUGE</p>							
CHK	DATE	CHANGE	REV	REFERENCE	DRAWN	NAME	
CNA1	14JAN09	TITLE WAS CIRCUIT	A	61254R	U00K640	CIRCUIT DIAGRAM, PROSTAR, LONESTAR	
		DIAGRAM, PROSTAR			RELEASE NO. 59637L	DATE 30APR06	PART NO. AE08055900 SHEET 003

**Figure 133 Engine Oil Pressure and Temperature, Speedometer, Tachometer, Voltmeter and Water Temp. Gauges**

8.4. ENGINE OIL AND TRANSMISSION OIL TEMPERATURE GAUGES, P. 4

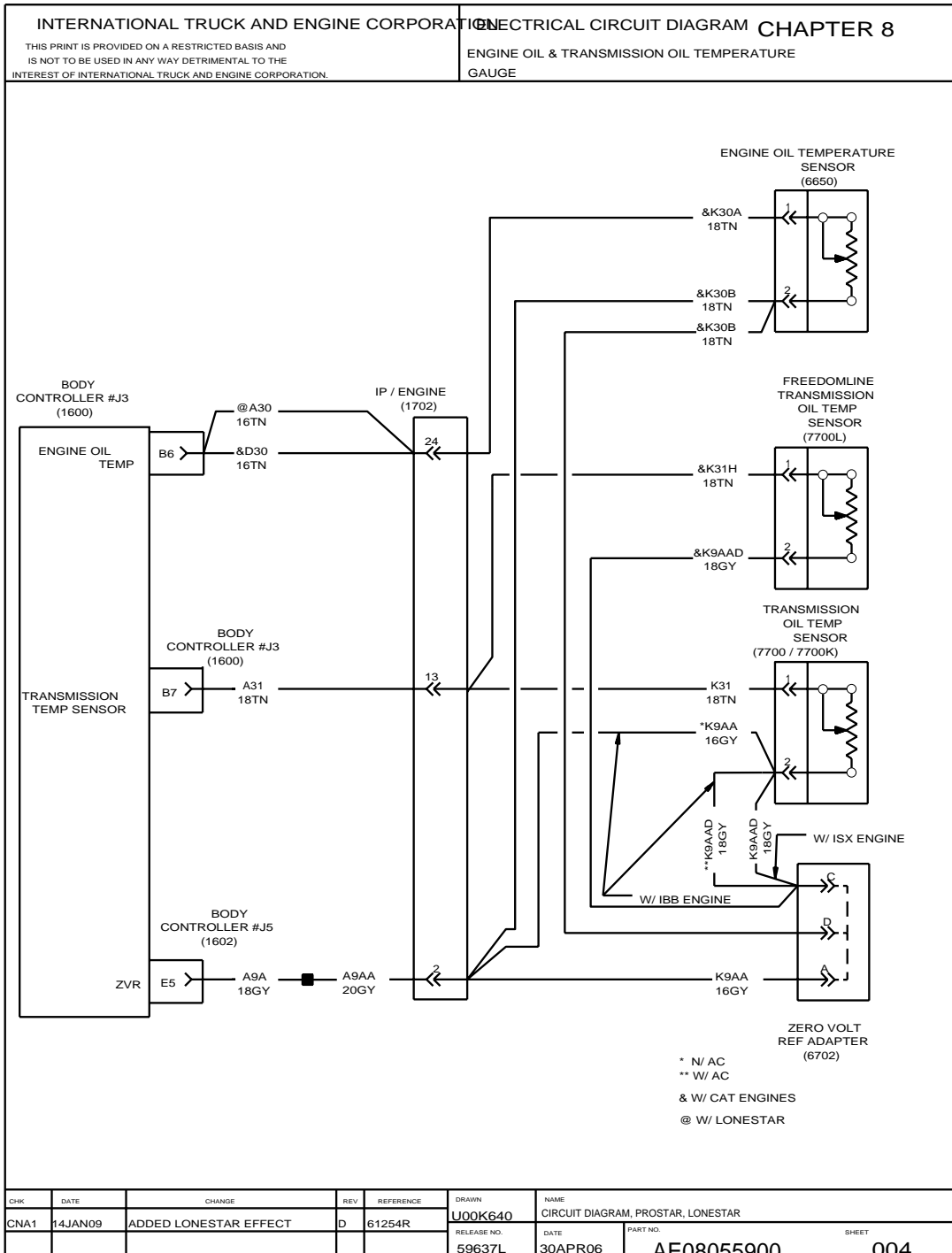


Figure 134 Engine Oil and Transmission Oil Temperature Gauges

8.5. FUEL HEATER, P. 5

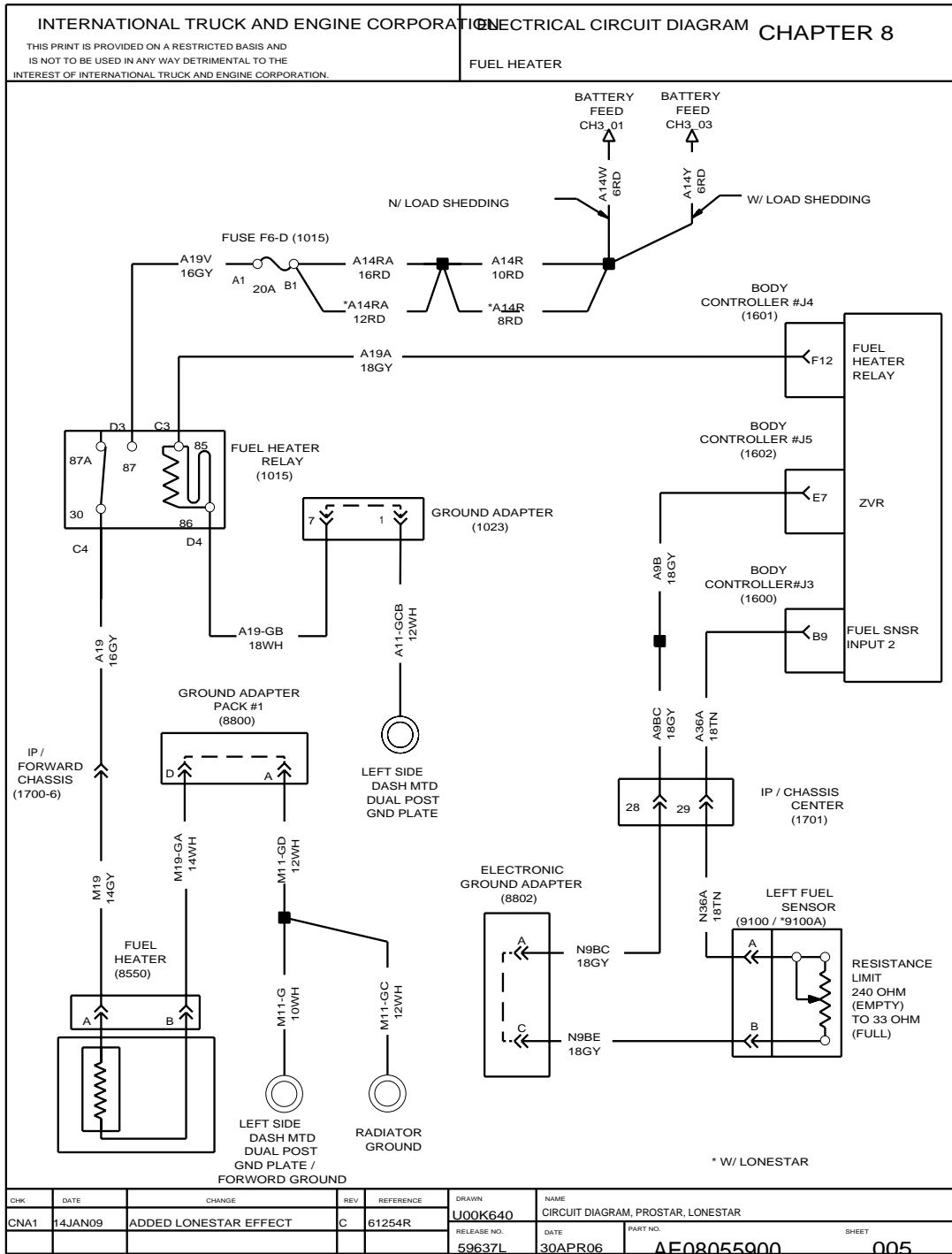


Figure 135 Fuel Heater

8.6. FUEL TRANSFER PUMP FOR DUAL TANK, P. 6

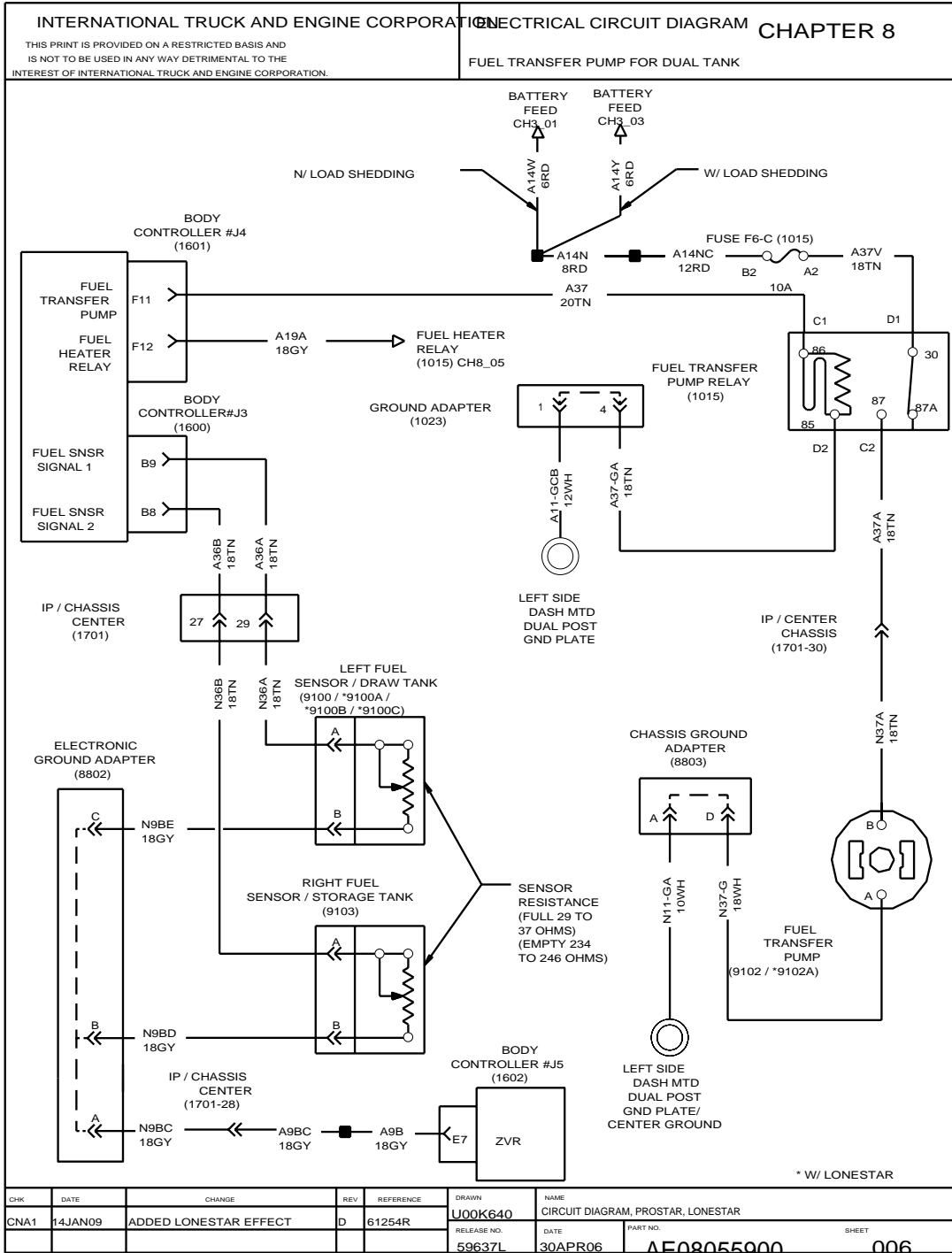


Figure 136 Fuel Transfer Pump for Dual Tank

8.7. DIFFERENTIAL LOCK AND OPTIONAL INDICATOR, P. 7

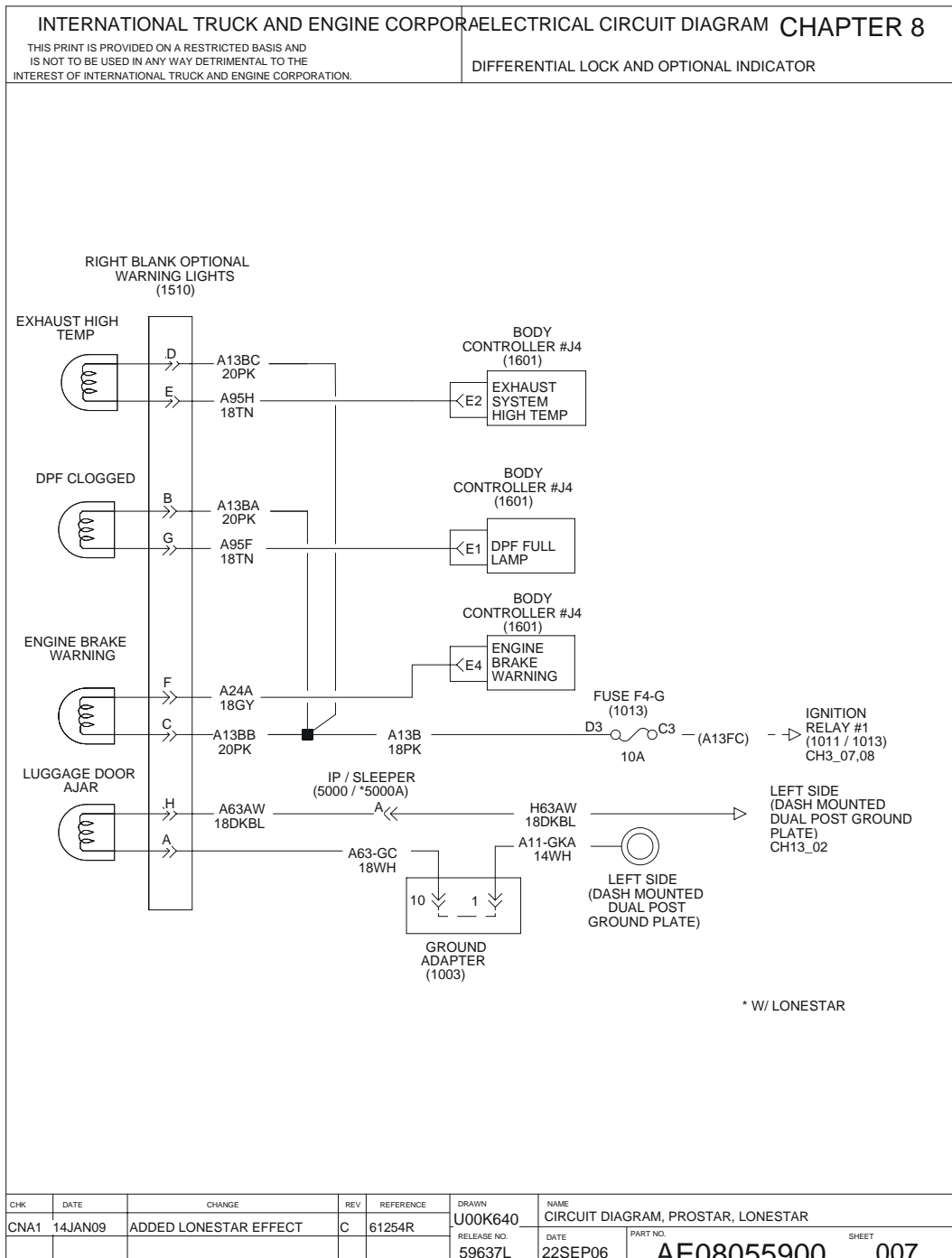


Figure 137 Differential Lock and Optional Indicator

8.8. DIFFERENTIAL LOCK AND OPTIONAL INDICATOR, P. 8

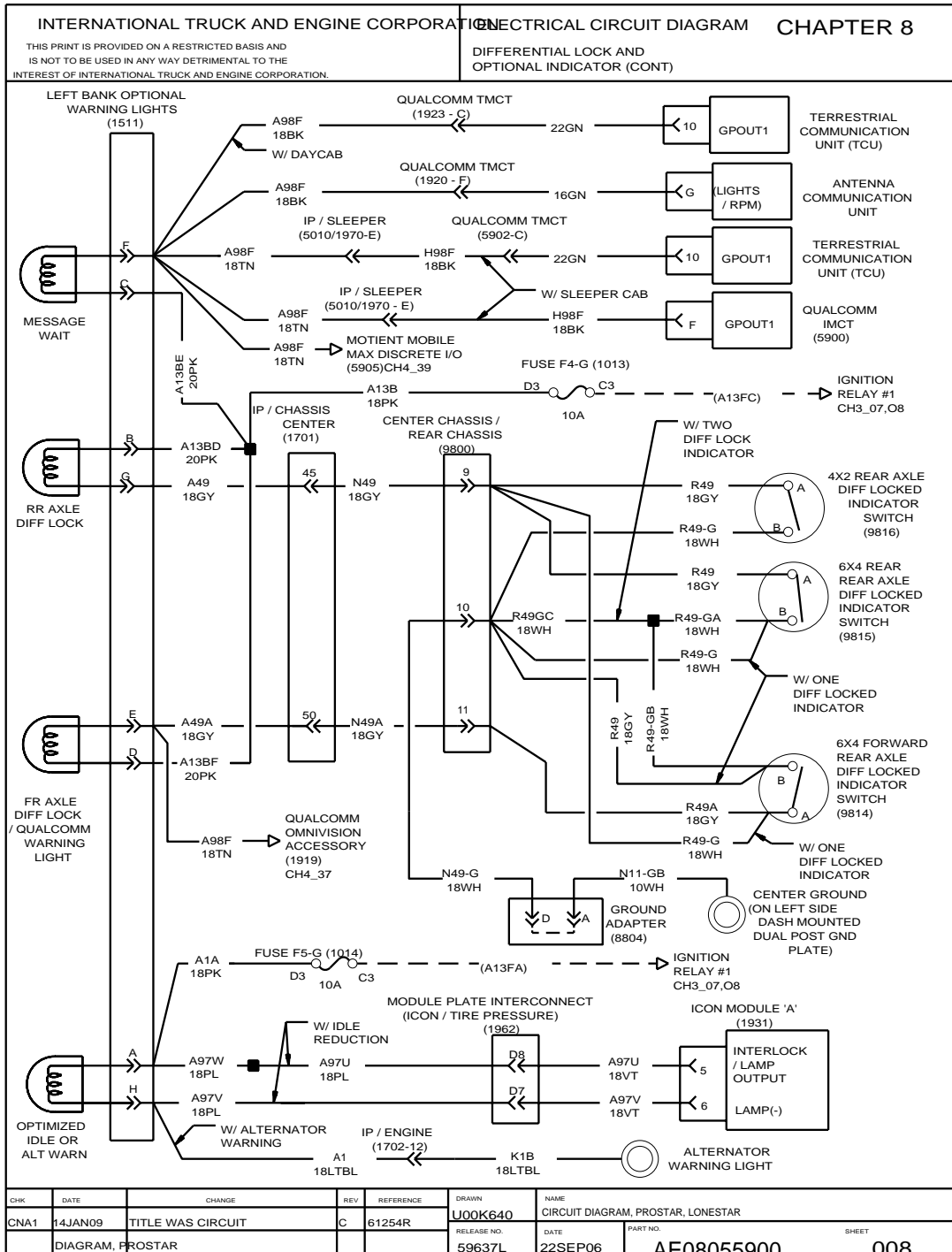


Figure 138 Differential Lock and Optional Indicator (Cont.)

8.9. BLANK PAGE, P. 9

INTERNATIONAL TRUCK AND ENGINE CORPORATION				ELECTRICAL CIRCUIT DIAGRAM				CHAPTER 8	
THIS PRINT IS PROVIDED ON A RESTRICTED BASIS AND IS NOT TO BE USED IN ANY WAY DETRIMENTAL TO THE INTEREST OF INTERNATIONAL TRUCK AND ENGINE CORPORATION.									
INTENTIONALLY LEFT BLANK									
CHK	DATE	CHANGE	REV	REFERENCE	DRAWN	NAME			
CNA1	14JAN09	TITLE WAS CIRCUIT	B	61254R	U00K640	CIRCUIT DIAGRAM, PROSTAR, LONESTAR			
					RELEASE NO.	DATE	PART NO.	SHEET	
					59637L	22SEP06	AE08055900	009	

Figure 139 Blank Page

8.10. IP / GAUGES, P. 10

INTERNATIONAL TRUCK AND ENGINE CORPORATION <small>THIS PRINT IS PROVIDED ON A RESTRICTED BASIS AND IS NOT TO BE USED IN ANY WAY DETRIMENTAL TO THE INTEREST OF INTERNATIONAL TRUCK AND ENGINE CORPORATION.</small>		ELECTRICAL CIRCUIT DIAGRAM    CHAPTER 8 IP / GAUGES																																																																									
<table border="1" style="width:100%; border-collapse: collapse;"> <thead> <tr> <th colspan="4">INSTRUMENT PANEL GAUGE CLUSTER</th> </tr> <tr> <th style="width:15%;">GAUGE</th> <th style="width:10%;">WARN LIGHT</th> <th style="width:55%;">SIGNAL PATH</th> <th style="width:20%;">SENSOR LOCATION</th> </tr> </thead> <tbody> <tr> <td>RPM (TACH)</td> <td>NO</td> <td>ENGINE CONT / DRIVE TRAIN J1939 / CLUSTER</td> <td>ENGINE</td> </tr> <tr> <td>MPH/KPH (SPD)</td> <td>NO</td> <td>ENGINE CONT / DRIVE TRAIN J1939 / CLUSTER</td> <td>TRANSMISSION</td> </tr> <tr> <td>FUEL</td> <td>YES</td> <td>BODY CONT / DRIVE TRAIN J1939 / CLUSTER</td> <td>FUEL TANK</td> </tr> <tr> <td>VOLT</td> <td>YES</td> <td>BODY CONT / DRIVE TRAIN J1939 / CLUSTER</td> <td>-</td> </tr> <tr> <td>AIR 1 (PRES)</td> <td>YES</td> <td>BODY CONT / DRIVE TRAIN J1939 / CLUSTER</td> <td>DRIVER CONTROL MODULE</td> </tr> <tr> <td>AIR 2 (PRES)</td> <td>YES</td> <td>BODY CONT / DRIVE TRAIN J1939 / CLUSTER</td> <td>DRIVER CONTROL MODULE</td> </tr> <tr> <td>WATER (TEMP)</td> <td>YES</td> <td>ENGINE CONT / DRIVE TRAIN J1939 / CLUSTER</td> <td>ENGINE</td> </tr> <tr> <td>ENG OIL (TEMP)</td> <td>YES</td> <td>ENGINE CONT / DRIVE TRAIN J1939 / CLUSTER</td> <td>ENGINE</td> </tr> <tr> <td>OIL (PRES)</td> <td>YES</td> <td>ENGINE CONT / DRIVE TRAIN J1939 / CLUSTER</td> <td>ENGINE</td> </tr> <tr> <td>TRANS. (TEMP)</td> <td>YES</td> <td>BODY CONT / DRIVE TRAIN J1939 / CLUSTER</td> <td>TRANSMISSION</td> </tr> </tbody> </table> <table border="1" style="width:100%; border-collapse: collapse;"> <thead> <tr> <th colspan="4">SECONDARY GAUGE CLUSTER</th> </tr> <tr> <th style="width:15%;">GAUGE</th> <th style="width:10%;">WARN LIGHT</th> <th style="width:55%;">SIGNAL PATH</th> <th style="width:20%;">SENSOR LOCATION</th> </tr> </thead> <tbody> <tr> <td>REAR RR AXLE OIL TEMP</td> <td>YES</td> <td>BODY CONT / DRIVE TRAIN J1939 / CLUSTER</td> <td>REAR RR AXLE</td> </tr> <tr> <td>FORWARD RR AXLE OIL TEMP</td> <td>YES</td> <td>BODY CONT / DRIVE TRAIN J1939 / CLUSTER</td> <td>FORWARD RR AXLE</td> </tr> <tr> <td>BOOST PRESSURE</td> <td>NO</td> <td>ENGINE CONT / DRIVE TRAIN J1939 / CLUSTER</td> <td>ENGINE</td> </tr> <tr> <td>AIR APPLICATION</td> <td>NO</td> <td>BODY CONT / DRIVE TRAIN J1939 / CLUSTER</td> <td>DRIVER CONTROL MODULE</td> </tr> </tbody> </table> <p>NOTES:                  1. WARNING LIGHTS ARE PART OF THE GAUGES AND LOCATED IN THE GAUGE CLUSTER</p>				INSTRUMENT PANEL GAUGE CLUSTER				GAUGE	WARN LIGHT	SIGNAL PATH	SENSOR LOCATION	RPM (TACH)	NO	ENGINE CONT / DRIVE TRAIN J1939 / CLUSTER	ENGINE	MPH/KPH (SPD)	NO	ENGINE CONT / DRIVE TRAIN J1939 / CLUSTER	TRANSMISSION	FUEL	YES	BODY CONT / DRIVE TRAIN J1939 / CLUSTER	FUEL TANK	VOLT	YES	BODY CONT / DRIVE TRAIN J1939 / CLUSTER	-	AIR 1 (PRES)	YES	BODY CONT / DRIVE TRAIN J1939 / CLUSTER	DRIVER CONTROL MODULE	AIR 2 (PRES)	YES	BODY CONT / DRIVE TRAIN J1939 / CLUSTER	DRIVER CONTROL MODULE	WATER (TEMP)	YES	ENGINE CONT / DRIVE TRAIN J1939 / CLUSTER	ENGINE	ENG OIL (TEMP)	YES	ENGINE CONT / DRIVE TRAIN J1939 / CLUSTER	ENGINE	OIL (PRES)	YES	ENGINE CONT / DRIVE TRAIN J1939 / CLUSTER	ENGINE	TRANS. (TEMP)	YES	BODY CONT / DRIVE TRAIN J1939 / CLUSTER	TRANSMISSION	SECONDARY GAUGE CLUSTER				GAUGE	WARN LIGHT	SIGNAL PATH	SENSOR LOCATION	REAR RR AXLE OIL TEMP	YES	BODY CONT / DRIVE TRAIN J1939 / CLUSTER	REAR RR AXLE	FORWARD RR AXLE OIL TEMP	YES	BODY CONT / DRIVE TRAIN J1939 / CLUSTER	FORWARD RR AXLE	BOOST PRESSURE	NO	ENGINE CONT / DRIVE TRAIN J1939 / CLUSTER	ENGINE	AIR APPLICATION	NO	BODY CONT / DRIVE TRAIN J1939 / CLUSTER	DRIVER CONTROL MODULE
INSTRUMENT PANEL GAUGE CLUSTER																																																																											
GAUGE	WARN LIGHT	SIGNAL PATH	SENSOR LOCATION																																																																								
RPM (TACH)	NO	ENGINE CONT / DRIVE TRAIN J1939 / CLUSTER	ENGINE																																																																								
MPH/KPH (SPD)	NO	ENGINE CONT / DRIVE TRAIN J1939 / CLUSTER	TRANSMISSION																																																																								
FUEL	YES	BODY CONT / DRIVE TRAIN J1939 / CLUSTER	FUEL TANK																																																																								
VOLT	YES	BODY CONT / DRIVE TRAIN J1939 / CLUSTER	-																																																																								
AIR 1 (PRES)	YES	BODY CONT / DRIVE TRAIN J1939 / CLUSTER	DRIVER CONTROL MODULE																																																																								
AIR 2 (PRES)	YES	BODY CONT / DRIVE TRAIN J1939 / CLUSTER	DRIVER CONTROL MODULE																																																																								
WATER (TEMP)	YES	ENGINE CONT / DRIVE TRAIN J1939 / CLUSTER	ENGINE																																																																								
ENG OIL (TEMP)	YES	ENGINE CONT / DRIVE TRAIN J1939 / CLUSTER	ENGINE																																																																								
OIL (PRES)	YES	ENGINE CONT / DRIVE TRAIN J1939 / CLUSTER	ENGINE																																																																								
TRANS. (TEMP)	YES	BODY CONT / DRIVE TRAIN J1939 / CLUSTER	TRANSMISSION																																																																								
SECONDARY GAUGE CLUSTER																																																																											
GAUGE	WARN LIGHT	SIGNAL PATH	SENSOR LOCATION																																																																								
REAR RR AXLE OIL TEMP	YES	BODY CONT / DRIVE TRAIN J1939 / CLUSTER	REAR RR AXLE																																																																								
FORWARD RR AXLE OIL TEMP	YES	BODY CONT / DRIVE TRAIN J1939 / CLUSTER	FORWARD RR AXLE																																																																								
BOOST PRESSURE	NO	ENGINE CONT / DRIVE TRAIN J1939 / CLUSTER	ENGINE																																																																								
AIR APPLICATION	NO	BODY CONT / DRIVE TRAIN J1939 / CLUSTER	DRIVER CONTROL MODULE																																																																								
CHK	DATE	CHANGE	REV	REFERENCE	DRAWN	NAME																																																																					
CNA1	14JAN09	TITLE WAS CIRCUIT	B	61254R	U00K640	CIRCUIT DIAGRAM, PROSTAR, LONESTAR																																																																					
		DIAGRAM, PROSTAR			59637L	DATE	PART NO.																																																																				
						30AUG06	AE08055900																																																																				
							SHEET 010																																																																				

Figure 140 IP / Gauges

8.11. IP / GAUGES AND WARNING LIGHTS — GAUGE CLUSTER, P. 11

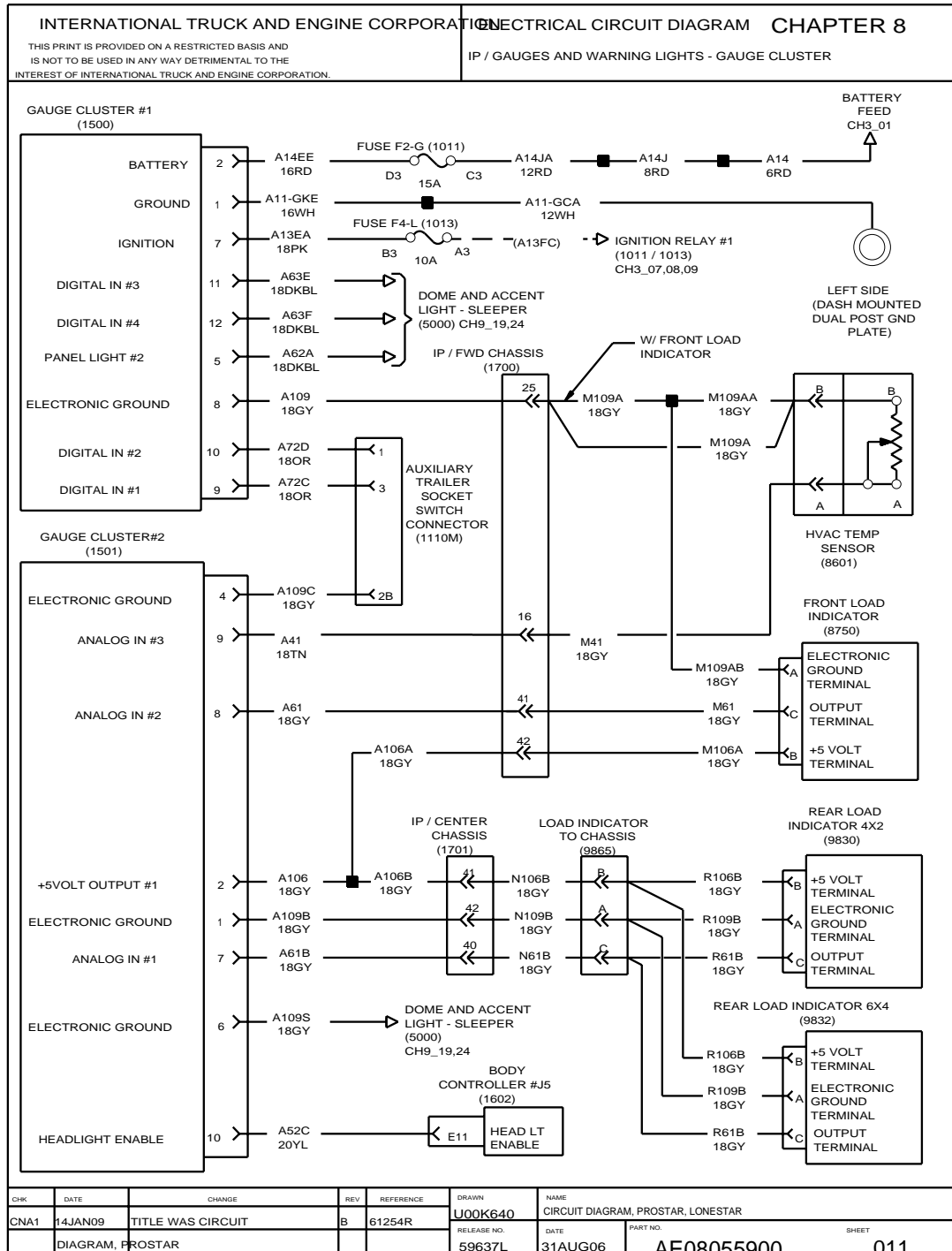


Figure 141 IP / Gauges and Warning Lights — Gauge Cluster

8.12. SECONDARY INSTRUMENT CLUSTER, P. 12

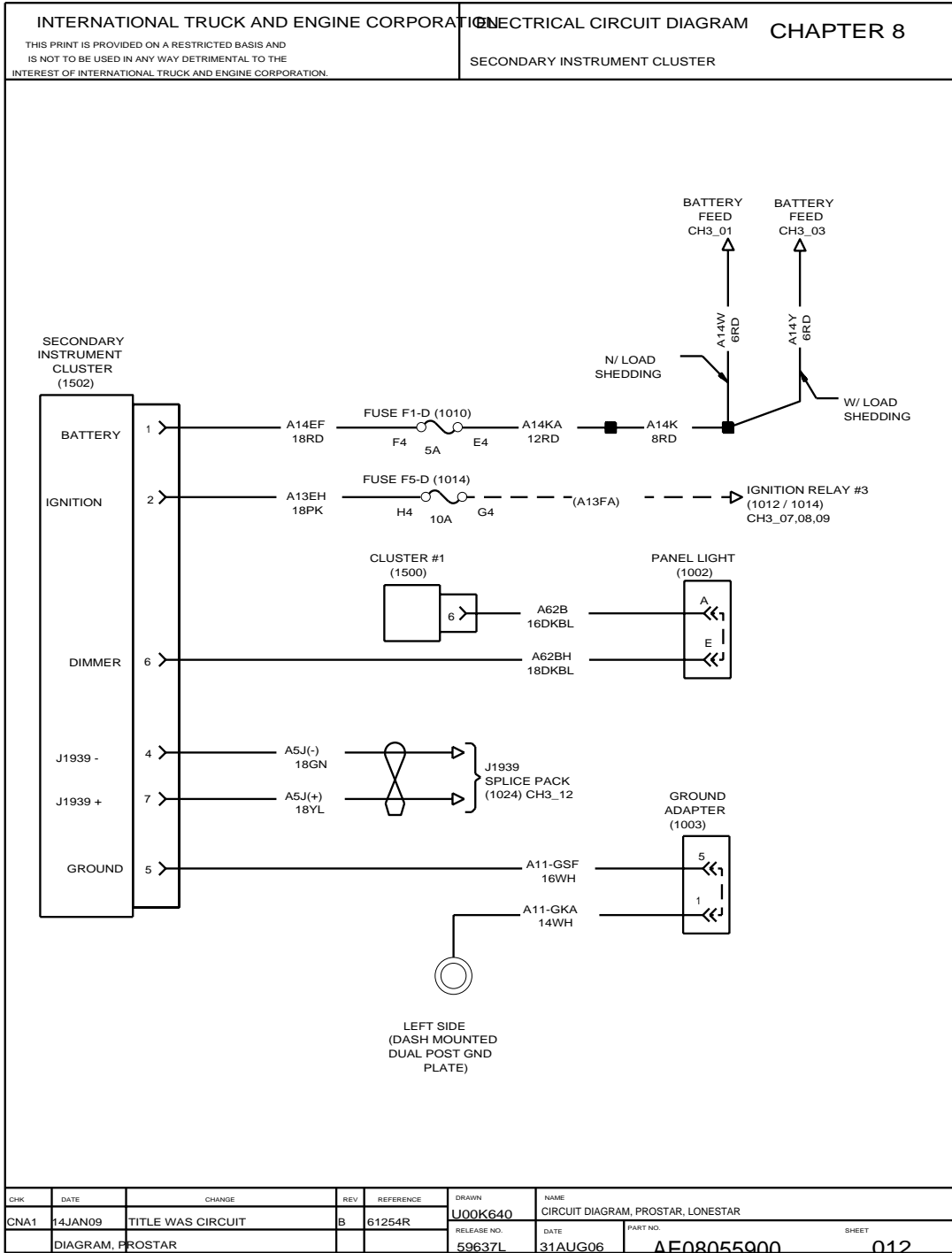


Figure 142 Secondary Instrument Cluster

8.13. PARKING WARNING LIGHT, P. 13

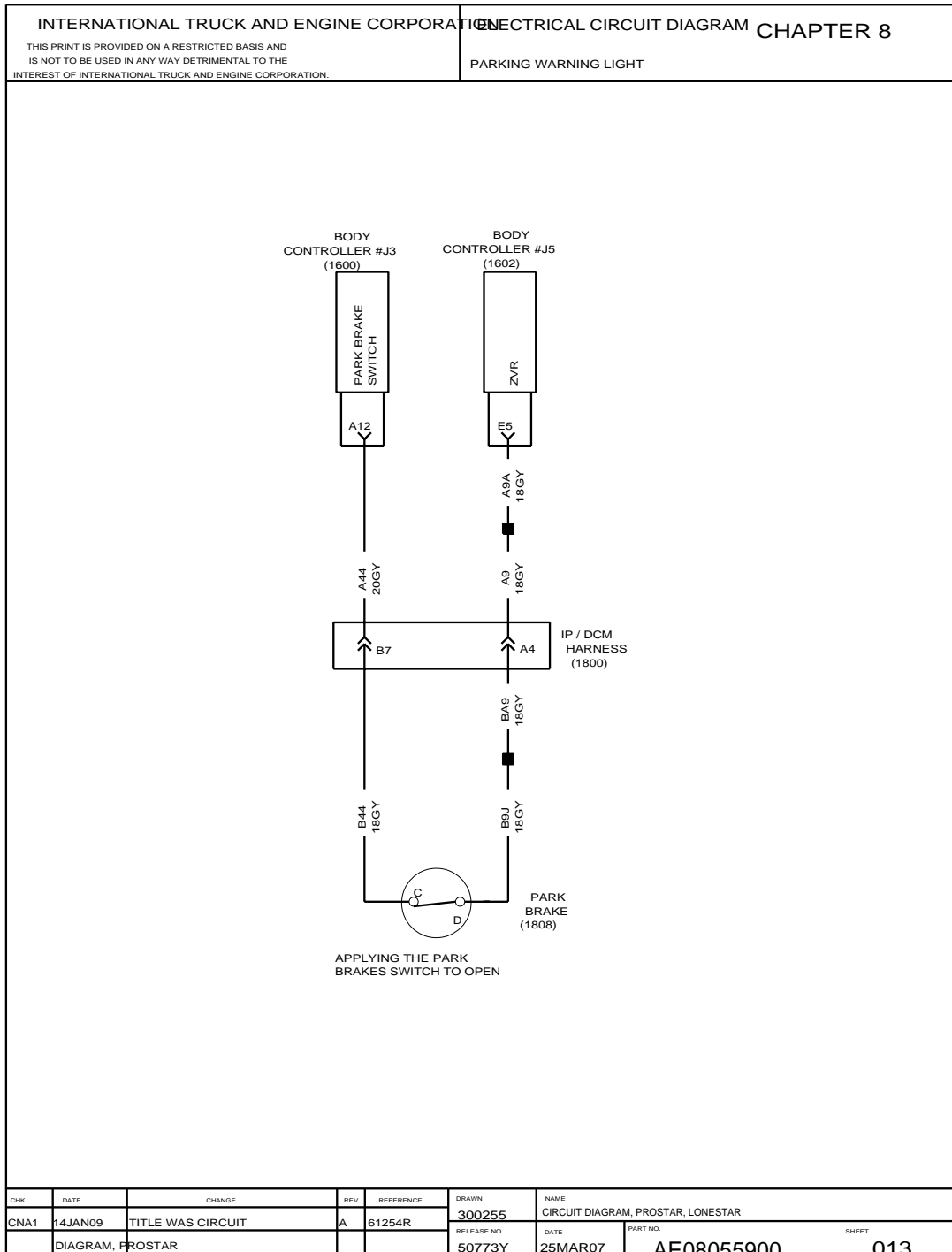


Figure 143 Parking Warning Light

8.14. WARNING LIGHTS, P. 14

INTERNATIONAL TRUCK AND ENGINE CORPORATION <small>THIS PRINT IS PROVIDED ON A RESTRICTED BASIS AND IS NOT TO BE USED IN ANY WAY DETRIMENTAL TO THE INTEREST OF INTERNATIONAL TRUCK AND ENGINE CORPORATION.</small>		ELECTRICAL CIRCUIT DIAGRAM    CHAPTER 8 WARNING LIGHTS																																																																																																													
<table border="1" style="width:100%; border-collapse: collapse;"> <thead> <tr> <th colspan="4">IP WARNING LIGHTS</th> </tr> <tr> <th style="width:25%;">WARNING LIGHT</th> <th style="width:25%;">REPRESENTATION</th> <th style="width:10%;">COLOR</th> <th style="width:40%;">SIGNAL PATH</th> </tr> </thead> <tbody> <tr> <td>RANGE INHIBITED</td> <td>RANGE INHIBITED</td> <td>YELLOW</td> <td>TCM / J1939 / CLUSTER</td> </tr> <tr> <td>PROTECT</td> <td>[ICON]</td> <td>YELLOW</td> <td>SAE DIAGNOSTIC LAMP</td> </tr> <tr> <td>RETARD OVER HEAT</td> <td>RETARD OVERHEAT</td> <td>YELLOW</td> <td>STATUS TRANSMITTED IN J1939 PROPRIETARY MESSAGE FROM BODY CONTROLLER</td> </tr> <tr> <td>AMBER WARN (AWL)</td> <td>[YIELD ICON]</td> <td>YELLOW</td> <td>STATUS TRANSMITTED IN J1939 MESSAGE FROM ANY MODULE SAE DIAGNOSTIC LAMP</td> </tr> <tr> <td>RED STOP (RSL)</td> <td>[STOP ICON]</td> <td>RED</td> <td>STATUS TRANSMITTED IN J1939 MESSAGE FROM ANY MODULE SAE DIAGNOSTIC LAMP</td> </tr> <tr> <td>BRAKE PRESSURE</td> <td>BRAKE PRESSURE [BRAKE ICON]</td> <td>RED</td> <td>STATUS TRANSMITTED IN J1939 PROPRIETARY MESSAGE FROM BODY CONTROLLER</td> </tr> <tr> <td>PARK BRAKE</td> <td>PARK [ICON]</td> <td>RED</td> <td>STATUS TRANSMITTED IN J1939 PROPRIETARY MESSAGE FROM BODY CONTROLLER</td> </tr> <tr> <td>EMERGENCY EXIT</td> <td>EMERG EXIT</td> <td>RED</td> <td>STATUS TRANSMITTED IN J1939 PROPRIETARY MESSAGE FROM BODY CONTROLLER</td> </tr> <tr> <td>LIFT DOOR</td> <td>LIFT DOOR</td> <td>YELLOW</td> <td>STATUS TRANSMITTED IN J1939 PROPRIETARY MESSAGE FROM BODY CONTROLLER</td> </tr> <tr> <td>TRAILER ABS</td> <td>ABS [TRAILER ICON]</td> <td>YELLOW</td> <td>STATUS TRANSMITTED IN J1939 MESSAGE FROM ABS</td> </tr> <tr> <td>WAIT TO START</td> <td>WAIT TO START</td> <td>YELLOW</td> <td>STATUS TRANSMITTED IN J1939 PROPRIETARY MESSAGE FROM BODY CONTROLLER</td> </tr> <tr> <td>TRACTION CONTROL</td> <td>TRAC CTRL</td> <td>YELLOW</td> <td>STATUS TRANSMITTED IN J1939 MESSAGE FROM ABS</td> </tr> <tr> <td>IDLE SHUTDOWN</td> <td>IDLE SHUTDOWN</td> <td>YELLOW</td> <td>STATUS TRANSMITTED IN J1939 MESSAGE FROM ECM</td> </tr> <tr> <td>MALEFUNCTION (MIL)</td> <td>[ICON]</td> <td>YELLOW</td> <td>SAE DIAGNOSTIC LAMP</td> </tr> <tr> <td>PTO ENGAGED INDICATOR</td> <td>PTO</td> <td>YELLOW</td> <td>STATUS TRANSMITTED IN J1939 PROPRIETARY MESSAGE FROM BODY CONTROLLER</td> </tr> <tr> <td>SERVICE PARK</td> <td>SERVICE [ICON]</td> <td>RED</td> <td>STATUS TRANSMITTED IN J1939 PROPRIETARY MESSAGE FROM BODY CONTROLLER</td> </tr> <tr> <td>SEAT BELT</td> <td>FASTEN BELTS</td> <td>RED</td> <td>STATUS TRANSMITTED IN J1939 PROPRIETARY MESSAGE FROM BODY CONTROLLER</td> </tr> <tr> <td>BRAKE FLUID</td> <td>BRAKE FLUID [ICON]</td> <td>RED</td> <td>BODY CONT / J1939 / CLUSTER</td> </tr> <tr> <td>RED FLASHER</td> <td>RED FLASHER</td> <td>RED</td> <td>STATUS TRANSMITTED IN J1939 PROPRIETARY MESSAGE FROM BODY CONTROLLER</td> </tr> <tr> <td>AMBER FLASHER</td> <td>AMBER FLASHER</td> <td>YELLOW</td> <td>STATUS TRANSMITTED IN J1939 PROPRIETARY MESSAGE FROM BODY CONTROLLER</td> </tr> <tr> <td>ANTILOCK BRAKING SYSTEM</td> <td>[ABS ICON]</td> <td>YELLOW</td> <td>STATUS TRANSMITTED IN J1939 MESSAGE FROM ABS</td> </tr> <tr> <td>ECONOMY MODE</td> <td>ECON</td> <td>YELLOW</td> <td>STATUS TRANSMITTED IN J1939 MESSAGE FROM TCM</td> </tr> <tr> <td>LEFT TURN</td> <td>[ARROW ICON]</td> <td>GREEN</td> <td>STATUS TRANSMITTED IN J1939 PROPRIETARY MESSAGE FROM BODY CONTROLLER</td> </tr> <tr> <td>HIGH BEAM</td> <td>[ICON]</td> <td>BLUE</td> <td>STATUS TRANSMITTED IN J1939 PROPRIETARY MESSAGE FROM BODY CONTROLLER</td> </tr> <tr> <td>RIGHT TURN</td> <td>[ARROW ICON]</td> <td>GREEN</td> <td>STATUS TRANSMITTED IN J1939 PROPRIETARY MESSAGE FROM BODY CONTROLLER</td> </tr> </tbody> </table>				IP WARNING LIGHTS				WARNING LIGHT	REPRESENTATION	COLOR	SIGNAL PATH	RANGE INHIBITED	RANGE INHIBITED	YELLOW	TCM / J1939 / CLUSTER	PROTECT	[ICON]	YELLOW	SAE DIAGNOSTIC LAMP	RETARD OVER HEAT	RETARD OVERHEAT	YELLOW	STATUS TRANSMITTED IN J1939 PROPRIETARY MESSAGE FROM BODY CONTROLLER	AMBER WARN (AWL)	[YIELD ICON]	YELLOW	STATUS TRANSMITTED IN J1939 MESSAGE FROM ANY MODULE SAE DIAGNOSTIC LAMP	RED STOP (RSL)	[STOP ICON]	RED	STATUS TRANSMITTED IN J1939 MESSAGE FROM ANY MODULE SAE DIAGNOSTIC LAMP	BRAKE PRESSURE	BRAKE PRESSURE [BRAKE ICON]	RED	STATUS TRANSMITTED IN J1939 PROPRIETARY MESSAGE FROM BODY CONTROLLER	PARK BRAKE	PARK [ICON]	RED	STATUS TRANSMITTED IN J1939 PROPRIETARY MESSAGE FROM BODY CONTROLLER	EMERGENCY EXIT	EMERG EXIT	RED	STATUS TRANSMITTED IN J1939 PROPRIETARY MESSAGE FROM BODY CONTROLLER	LIFT DOOR	LIFT DOOR	YELLOW	STATUS TRANSMITTED IN J1939 PROPRIETARY MESSAGE FROM BODY CONTROLLER	TRAILER ABS	ABS [TRAILER ICON]	YELLOW	STATUS TRANSMITTED IN J1939 MESSAGE FROM ABS	WAIT TO START	WAIT TO START	YELLOW	STATUS TRANSMITTED IN J1939 PROPRIETARY MESSAGE FROM BODY CONTROLLER	TRACTION CONTROL	TRAC CTRL	YELLOW	STATUS TRANSMITTED IN J1939 MESSAGE FROM ABS	IDLE SHUTDOWN	IDLE SHUTDOWN	YELLOW	STATUS TRANSMITTED IN J1939 MESSAGE FROM ECM	MALEFUNCTION (MIL)	[ICON]	YELLOW	SAE DIAGNOSTIC LAMP	PTO ENGAGED INDICATOR	PTO	YELLOW	STATUS TRANSMITTED IN J1939 PROPRIETARY MESSAGE FROM BODY CONTROLLER	SERVICE PARK	SERVICE [ICON]	RED	STATUS TRANSMITTED IN J1939 PROPRIETARY MESSAGE FROM BODY CONTROLLER	SEAT BELT	FASTEN BELTS	RED	STATUS TRANSMITTED IN J1939 PROPRIETARY MESSAGE FROM BODY CONTROLLER	BRAKE FLUID	BRAKE FLUID [ICON]	RED	BODY CONT / J1939 / CLUSTER	RED FLASHER	RED FLASHER	RED	STATUS TRANSMITTED IN J1939 PROPRIETARY MESSAGE FROM BODY CONTROLLER	AMBER FLASHER	AMBER FLASHER	YELLOW	STATUS TRANSMITTED IN J1939 PROPRIETARY MESSAGE FROM BODY CONTROLLER	ANTILOCK BRAKING SYSTEM	[ABS ICON]	YELLOW	STATUS TRANSMITTED IN J1939 MESSAGE FROM ABS	ECONOMY MODE	ECON	YELLOW	STATUS TRANSMITTED IN J1939 MESSAGE FROM TCM	LEFT TURN	[ARROW ICON]	GREEN	STATUS TRANSMITTED IN J1939 PROPRIETARY MESSAGE FROM BODY CONTROLLER	HIGH BEAM	[ICON]	BLUE	STATUS TRANSMITTED IN J1939 PROPRIETARY MESSAGE FROM BODY CONTROLLER	RIGHT TURN	[ARROW ICON]	GREEN	STATUS TRANSMITTED IN J1939 PROPRIETARY MESSAGE FROM BODY CONTROLLER
IP WARNING LIGHTS																																																																																																															
WARNING LIGHT	REPRESENTATION	COLOR	SIGNAL PATH																																																																																																												
RANGE INHIBITED	RANGE INHIBITED	YELLOW	TCM / J1939 / CLUSTER																																																																																																												
PROTECT	[ICON]	YELLOW	SAE DIAGNOSTIC LAMP																																																																																																												
RETARD OVER HEAT	RETARD OVERHEAT	YELLOW	STATUS TRANSMITTED IN J1939 PROPRIETARY MESSAGE FROM BODY CONTROLLER																																																																																																												
AMBER WARN (AWL)	[YIELD ICON]	YELLOW	STATUS TRANSMITTED IN J1939 MESSAGE FROM ANY MODULE SAE DIAGNOSTIC LAMP																																																																																																												
RED STOP (RSL)	[STOP ICON]	RED	STATUS TRANSMITTED IN J1939 MESSAGE FROM ANY MODULE SAE DIAGNOSTIC LAMP																																																																																																												
BRAKE PRESSURE	BRAKE PRESSURE [BRAKE ICON]	RED	STATUS TRANSMITTED IN J1939 PROPRIETARY MESSAGE FROM BODY CONTROLLER																																																																																																												
PARK BRAKE	PARK [ICON]	RED	STATUS TRANSMITTED IN J1939 PROPRIETARY MESSAGE FROM BODY CONTROLLER																																																																																																												
EMERGENCY EXIT	EMERG EXIT	RED	STATUS TRANSMITTED IN J1939 PROPRIETARY MESSAGE FROM BODY CONTROLLER																																																																																																												
LIFT DOOR	LIFT DOOR	YELLOW	STATUS TRANSMITTED IN J1939 PROPRIETARY MESSAGE FROM BODY CONTROLLER																																																																																																												
TRAILER ABS	ABS [TRAILER ICON]	YELLOW	STATUS TRANSMITTED IN J1939 MESSAGE FROM ABS																																																																																																												
WAIT TO START	WAIT TO START	YELLOW	STATUS TRANSMITTED IN J1939 PROPRIETARY MESSAGE FROM BODY CONTROLLER																																																																																																												
TRACTION CONTROL	TRAC CTRL	YELLOW	STATUS TRANSMITTED IN J1939 MESSAGE FROM ABS																																																																																																												
IDLE SHUTDOWN	IDLE SHUTDOWN	YELLOW	STATUS TRANSMITTED IN J1939 MESSAGE FROM ECM																																																																																																												
MALEFUNCTION (MIL)	[ICON]	YELLOW	SAE DIAGNOSTIC LAMP																																																																																																												
PTO ENGAGED INDICATOR	PTO	YELLOW	STATUS TRANSMITTED IN J1939 PROPRIETARY MESSAGE FROM BODY CONTROLLER																																																																																																												
SERVICE PARK	SERVICE [ICON]	RED	STATUS TRANSMITTED IN J1939 PROPRIETARY MESSAGE FROM BODY CONTROLLER																																																																																																												
SEAT BELT	FASTEN BELTS	RED	STATUS TRANSMITTED IN J1939 PROPRIETARY MESSAGE FROM BODY CONTROLLER																																																																																																												
BRAKE FLUID	BRAKE FLUID [ICON]	RED	BODY CONT / J1939 / CLUSTER																																																																																																												
RED FLASHER	RED FLASHER	RED	STATUS TRANSMITTED IN J1939 PROPRIETARY MESSAGE FROM BODY CONTROLLER																																																																																																												
AMBER FLASHER	AMBER FLASHER	YELLOW	STATUS TRANSMITTED IN J1939 PROPRIETARY MESSAGE FROM BODY CONTROLLER																																																																																																												
ANTILOCK BRAKING SYSTEM	[ABS ICON]	YELLOW	STATUS TRANSMITTED IN J1939 MESSAGE FROM ABS																																																																																																												
ECONOMY MODE	ECON	YELLOW	STATUS TRANSMITTED IN J1939 MESSAGE FROM TCM																																																																																																												
LEFT TURN	[ARROW ICON]	GREEN	STATUS TRANSMITTED IN J1939 PROPRIETARY MESSAGE FROM BODY CONTROLLER																																																																																																												
HIGH BEAM	[ICON]	BLUE	STATUS TRANSMITTED IN J1939 PROPRIETARY MESSAGE FROM BODY CONTROLLER																																																																																																												
RIGHT TURN	[ARROW ICON]	GREEN	STATUS TRANSMITTED IN J1939 PROPRIETARY MESSAGE FROM BODY CONTROLLER																																																																																																												
CHK	DATE	CHANGE	REV	REFERENCE	DRAWN	NAME																																																																																																									
CNA1	14JAN09	TITLE WAS CIRCUIT	B	61254R	U00K640	CIRCUIT DIAGRAM, PROSTAR, LONESTAR																																																																																																									
		DIAGRAM, PROSTAR			RELEASE NO. 60773Y	DATE 30APR06    PART NO. AE08055900    SHEET 014																																																																																																									

Figure 144 Warning Lights

**8.15. IP TEXT MESSAGES AND WARNING LIGHTS — CONTROLLED BY ENGINE, TRANSMISSION AND ABS CONTROLLER, P. 15**

INTERNATIONAL TRUCK AND ENGINE CORPORATION				ELECTRICAL CIRCUIT DIAGRAM CHAPTER 8			
THIS PRINT IS PROVIDED ON A RESTRICTED BASIS AND IS NOT TO BE USED IN ANY WAY DETRIMENTAL TO THE INTEREST OF INTERNATIONAL TRUCK AND ENGINE CORPORATION.				IP TEXT MESSAGES & WARNING LIGHTS - CONTROLLED BY ENGINE, TRANSMISSION AND ABS CONTROLLER			
<p>IP TEXT MESSAGES :</p> <p>LOAD SHEDDING</p> <p>WASHER FLUID LOW</p> <p>ELECTRICAL FAULT</p> <p>CHECK A / C</p> <p>AIR FILTER RESTRICTION</p> <p>EXTERIOR LAMP CHECK ACTIVE</p> <p>HVAC TEMP SETTING</p> <p>ACTIVATE HVAC FRONT BLOWER</p> <p>HVAC SLEEPER BLOWER SPEED</p> <p>AIR PRESSURE DIAGNOSTIC</p> <p>CRUISE</p> <p>FUEL FILTER</p> <p>THE FOLLOWING WARNING LIGHTS ARE CONTROLLED BY THE ENGINE, TRANSMISSION, OR ABS CONTROLLER OVER THE DATA BUS AND DO NOT HAVE INDEPENDENT CIRCUITRY THAT CAN BE OR NEEDS TO BE SHOWN:</p> <p>RANGE INHIBITED</p> <p>ECONOMY MODE</p> <p>TRAC CTRL</p> <p>TRAILER ABS</p> <p>ABS</p>							
CHK	DATE	CHANGE	REV	REFERENCE	DRAWN	NAME	
CNA1	14JAN09	TITLE WAS CIRCUIT	A	61254R	U00K640	CIRCUIT DIAGRAM, PROSTAR, LONESTAR	
	DIAGRAM, PROSTAR				RELEASE NO. 60773Y	DATE 30APR06	
					PART NO. AE08055900	SHEET 015	

**Figure 145 IP Text Messages and Warning Lights — Controlled by Engine, Transmission and ABS Controller**

8.16. DIFFERENTIAL LOCK AND OPTIONAL INDICATOR, P. 16

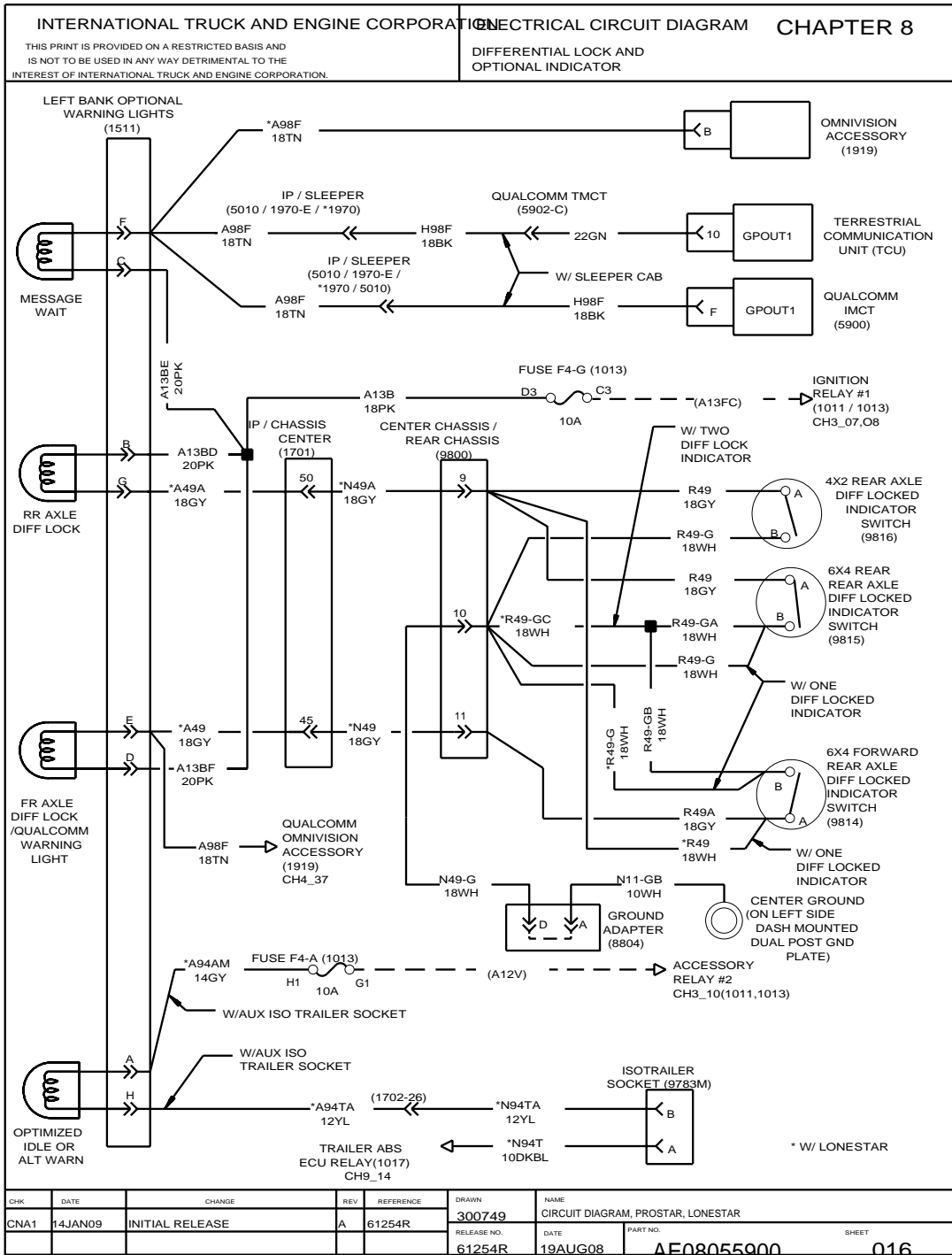


Figure 146 Differential Lock and Optional Indicator

## 9. LIGHTING SYSTEM (CHAPTER 9)

### 9.1. LIGHTS — STOP, TAIL, TURN AND BACK-UP N/FREEDOMLINE, P. 1

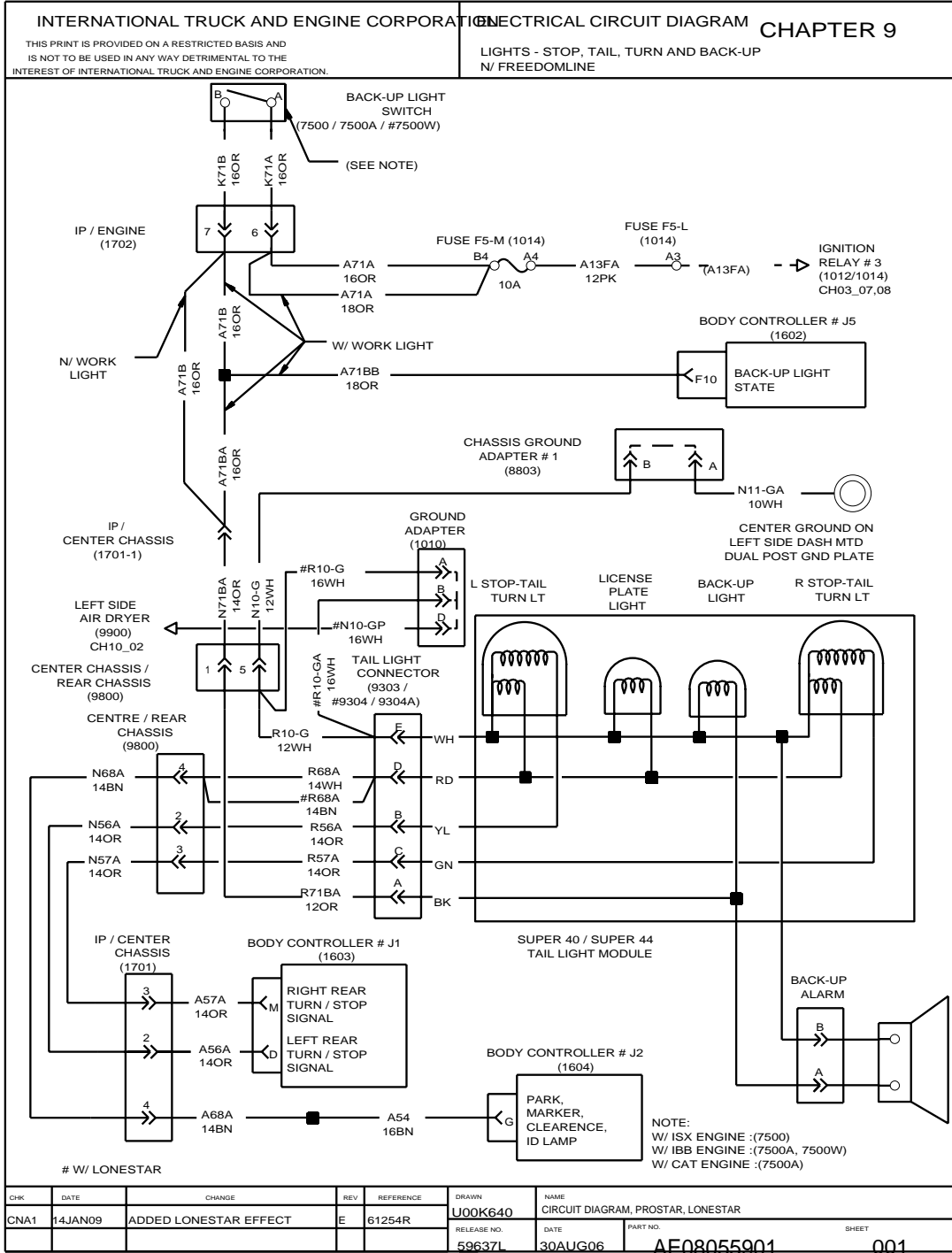


Figure 147 Lights — Stop, Tail, Turn and Back-Up N/Freedomline

9.2. LIGHTS — STOP, TAIL, TURN AND BACK-UP N/FREEDOMLINE, P. 1A

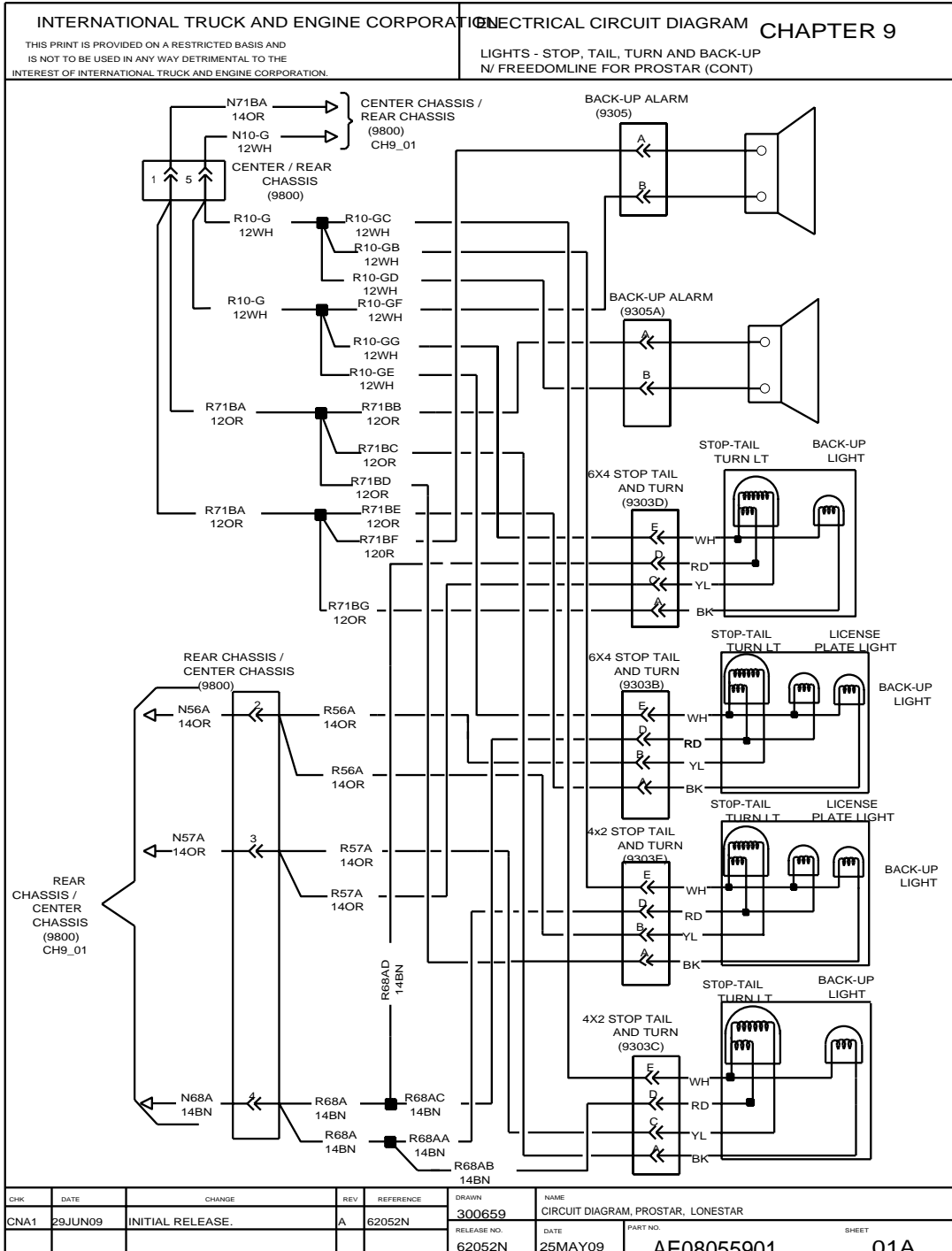


Figure 148 Lights — Stop, Tail, Turn and Back-Up N/Freedomline

9.3. LIGHTS — STOP, TAIL, TURN AND BACK-UP W/FREEDOMLINE, P. 2

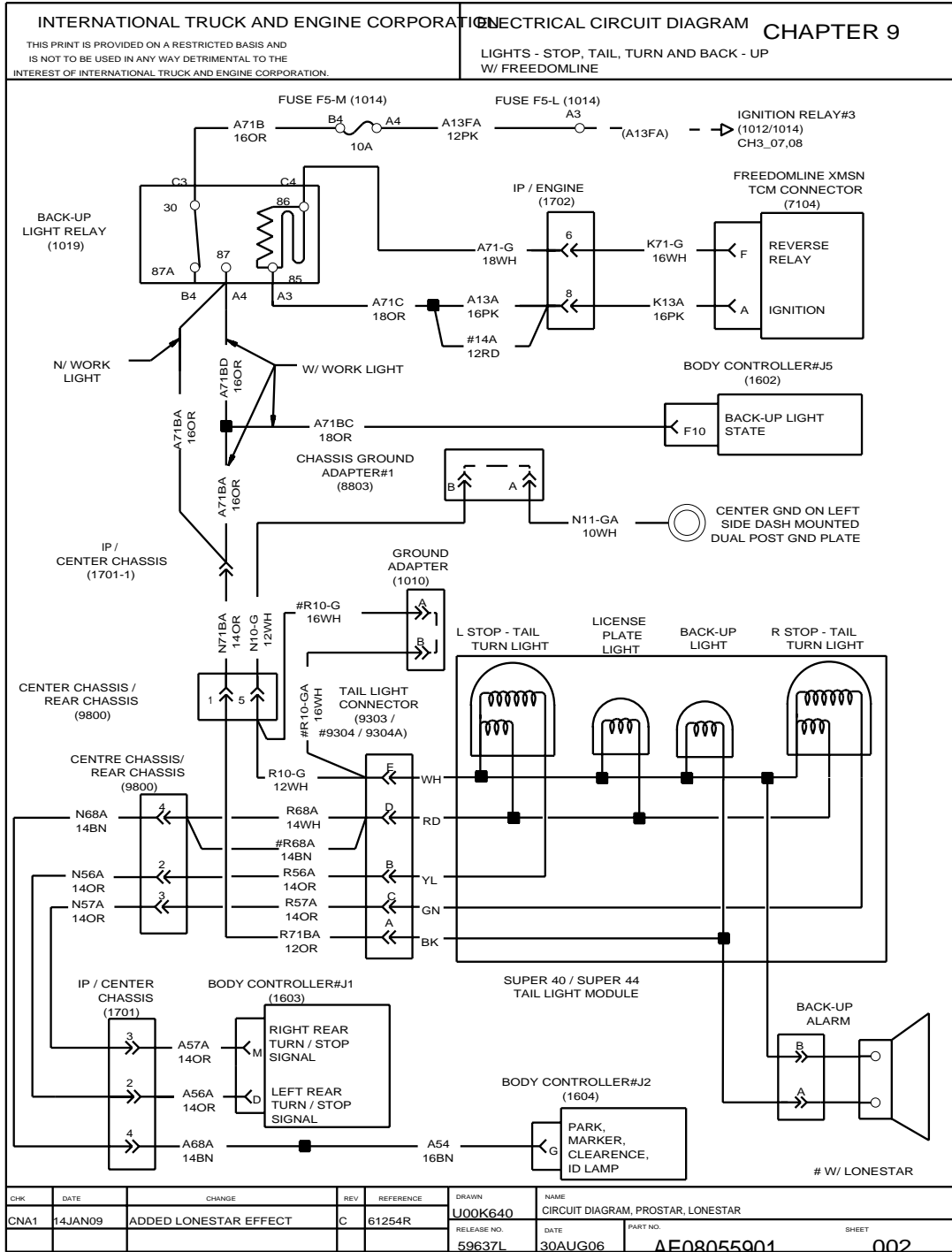


Figure 149 Lights — Stop, Tail, Turn and Back-Up W/Freedomline

9.4. LIGHTS — STOP, TAIL, TURN AND BACK-UP W/FREEDOMLINE, P. 2A

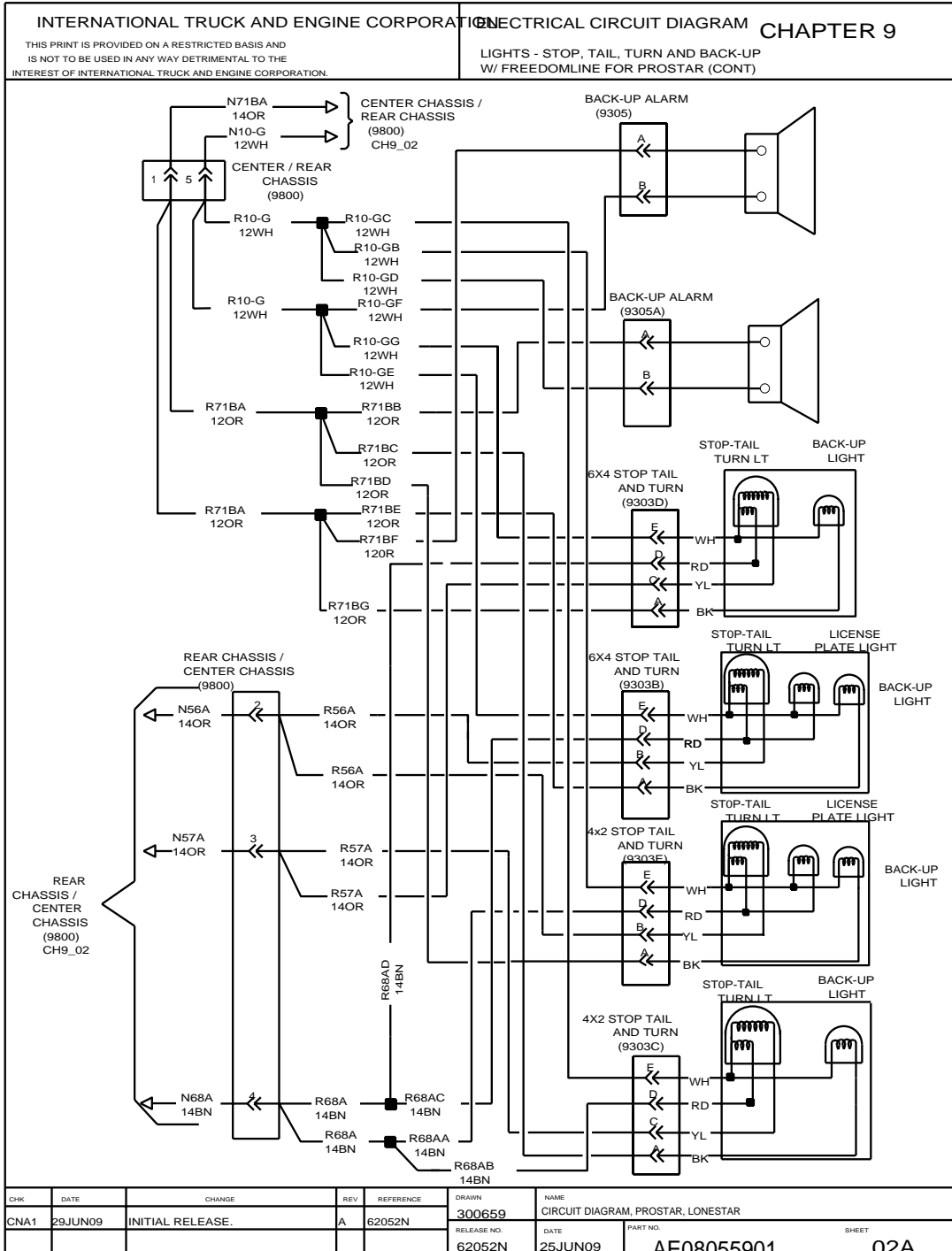


Figure 150 Lights — Stop, Tail, Turn and Back-Up W/Freedomline

9.5. DOME/MAP AND COURTESY LIGHTS — DAY CAB, P. 3

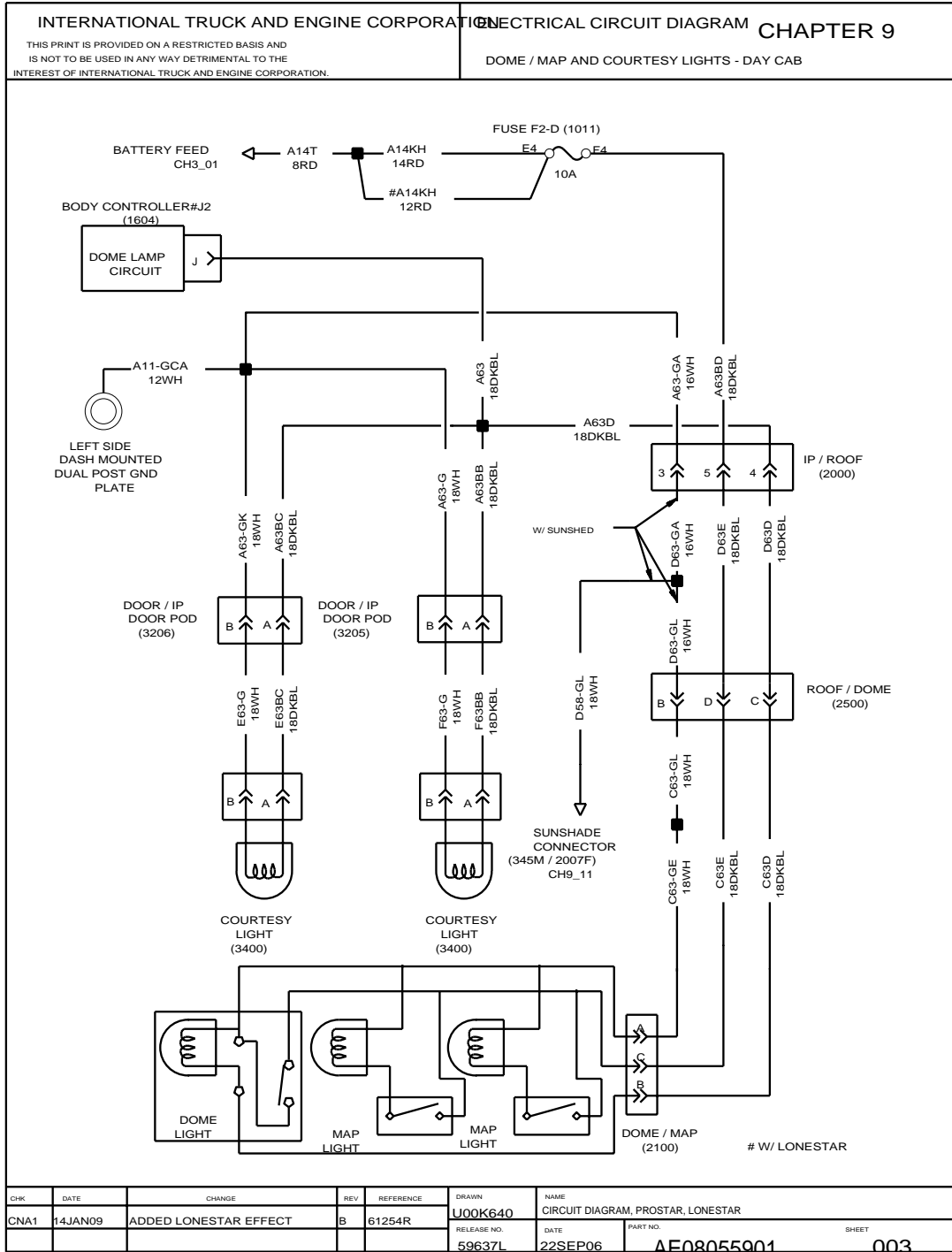


Figure 151 Dome/Map and Courtesy Lights — Day Cab

9.6. DOME/MAP AND COURTESY LIGHTS — SLEEPER, P. 4

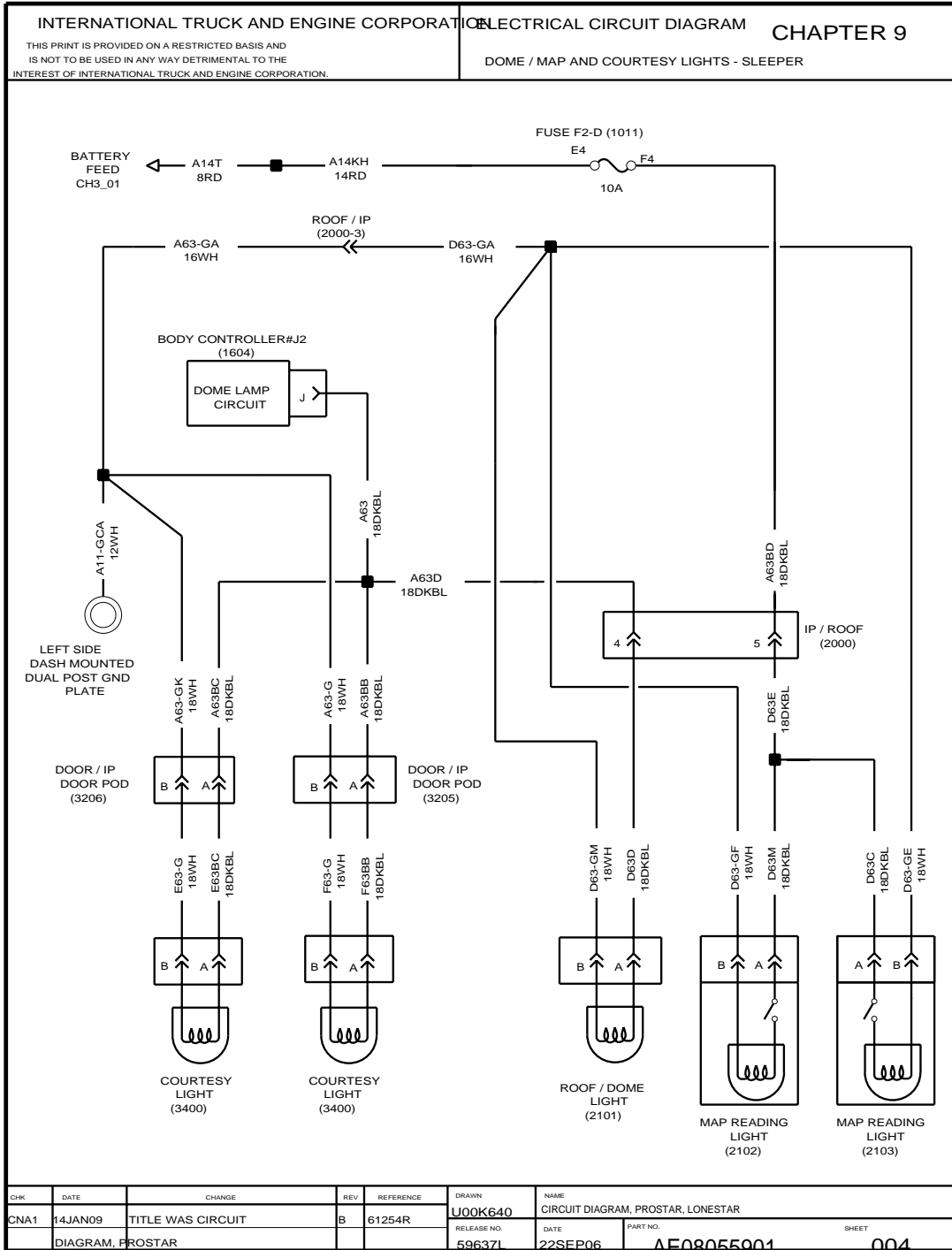


Figure 152 Dome/Map and Courtesy Lights — Sleeper

9.7. FOG LIGHTS AND SPOT LIGHT, P. 5

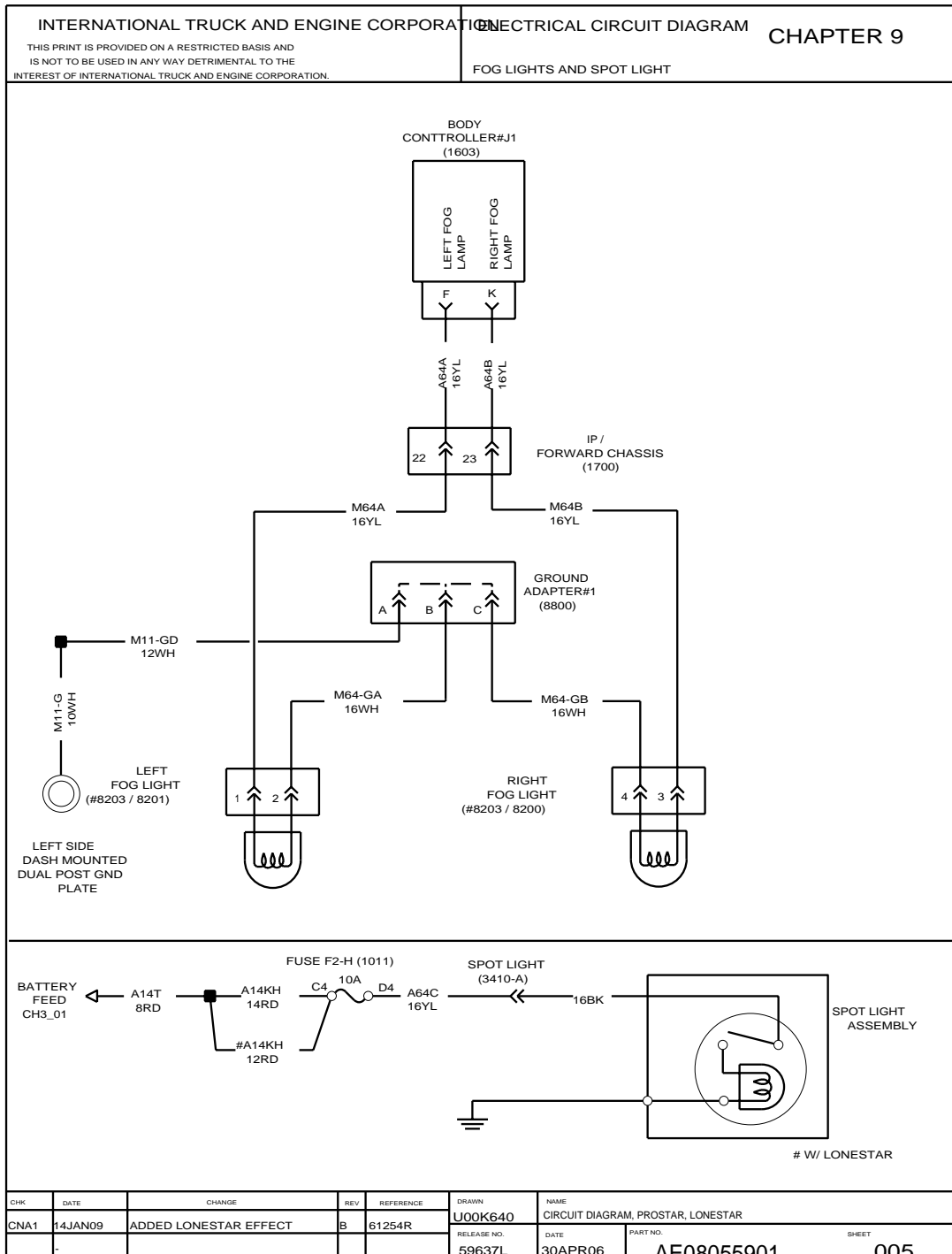


Figure 153 Fog Lights and Spot Light

9.8. HEADLIGHTS, P. 6

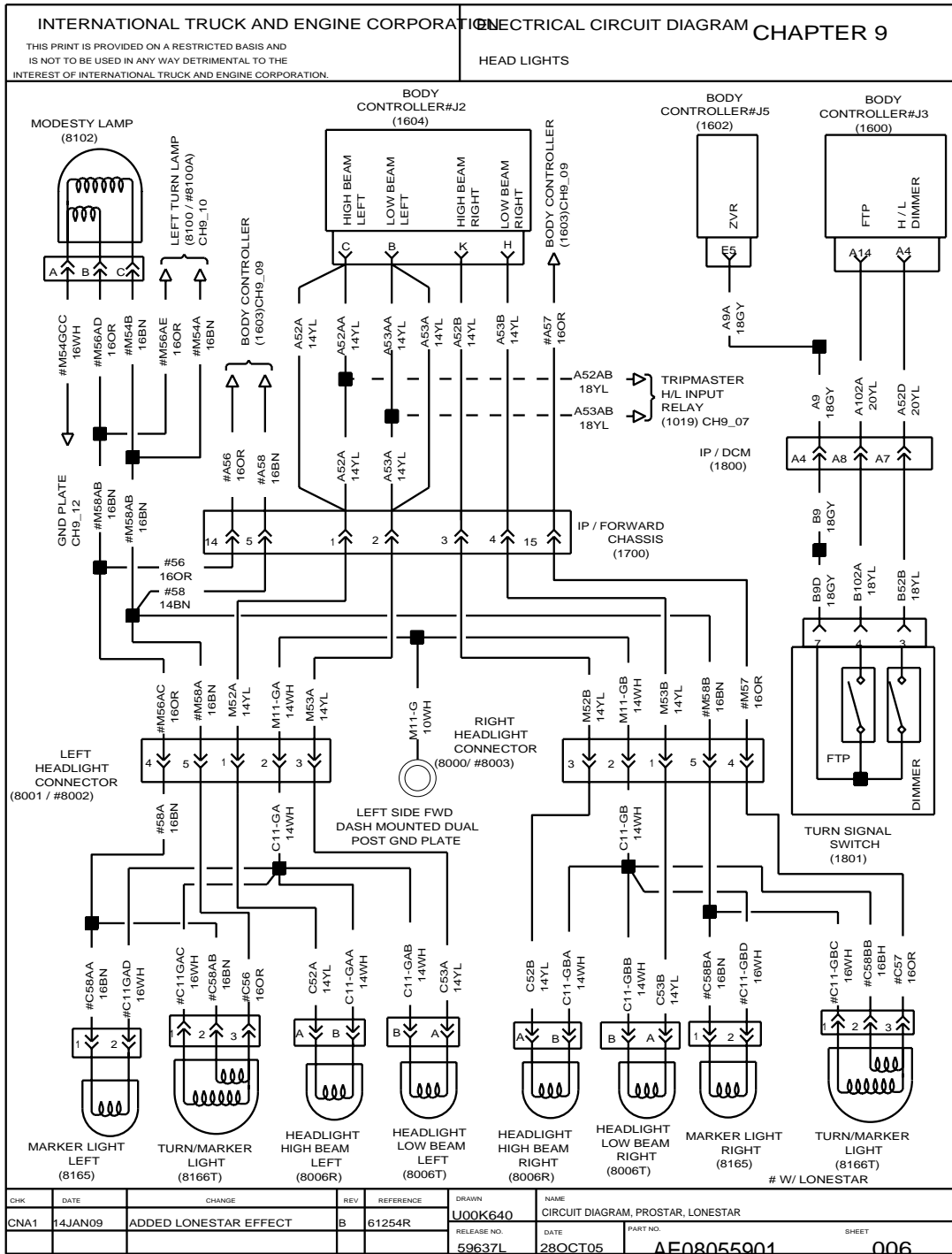


Figure 154 Headlights

9.9. TRIPMASTER, P. 7

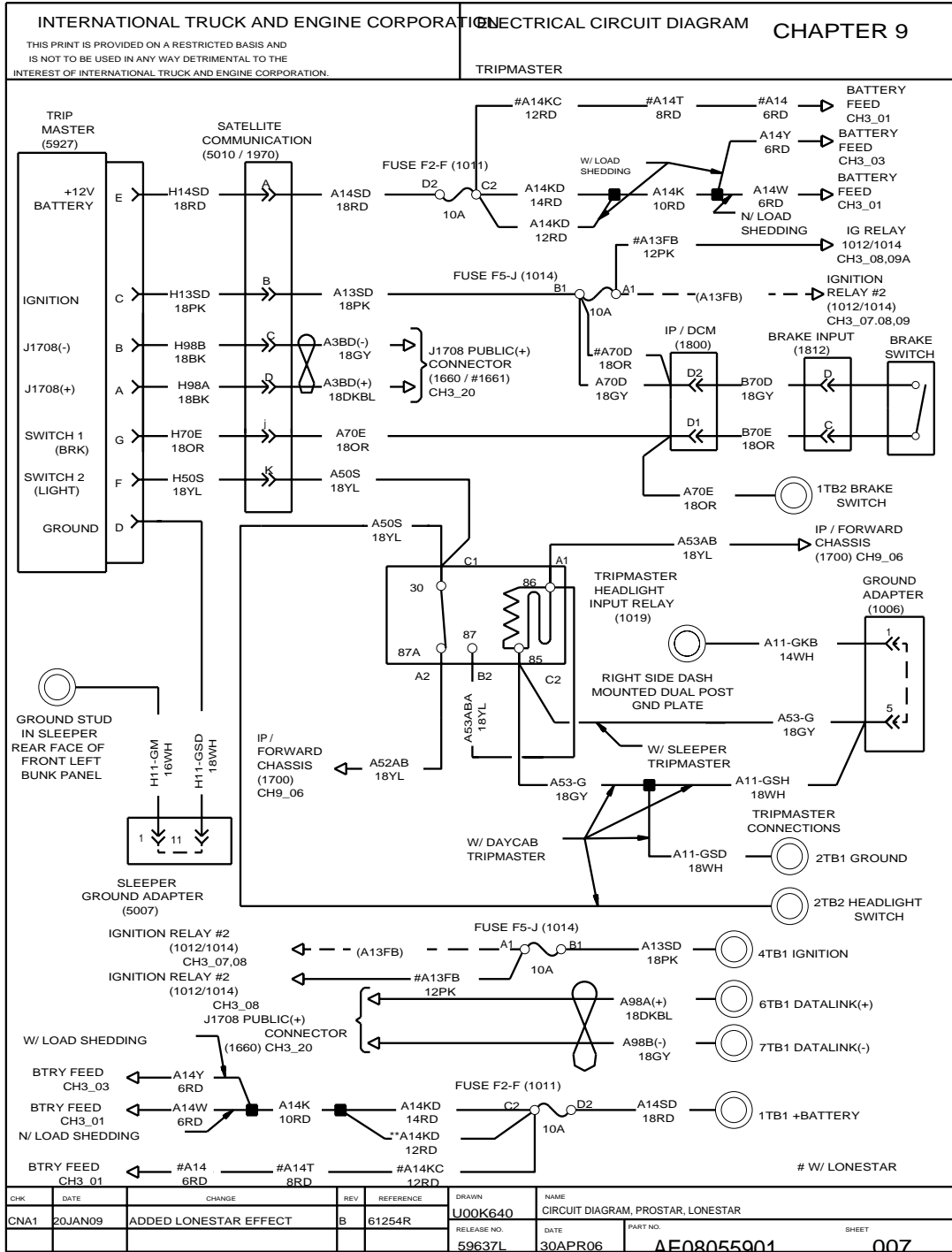


Figure 155 Tripmaster

9.10. TURN AND STOP SWITCH, P. 8

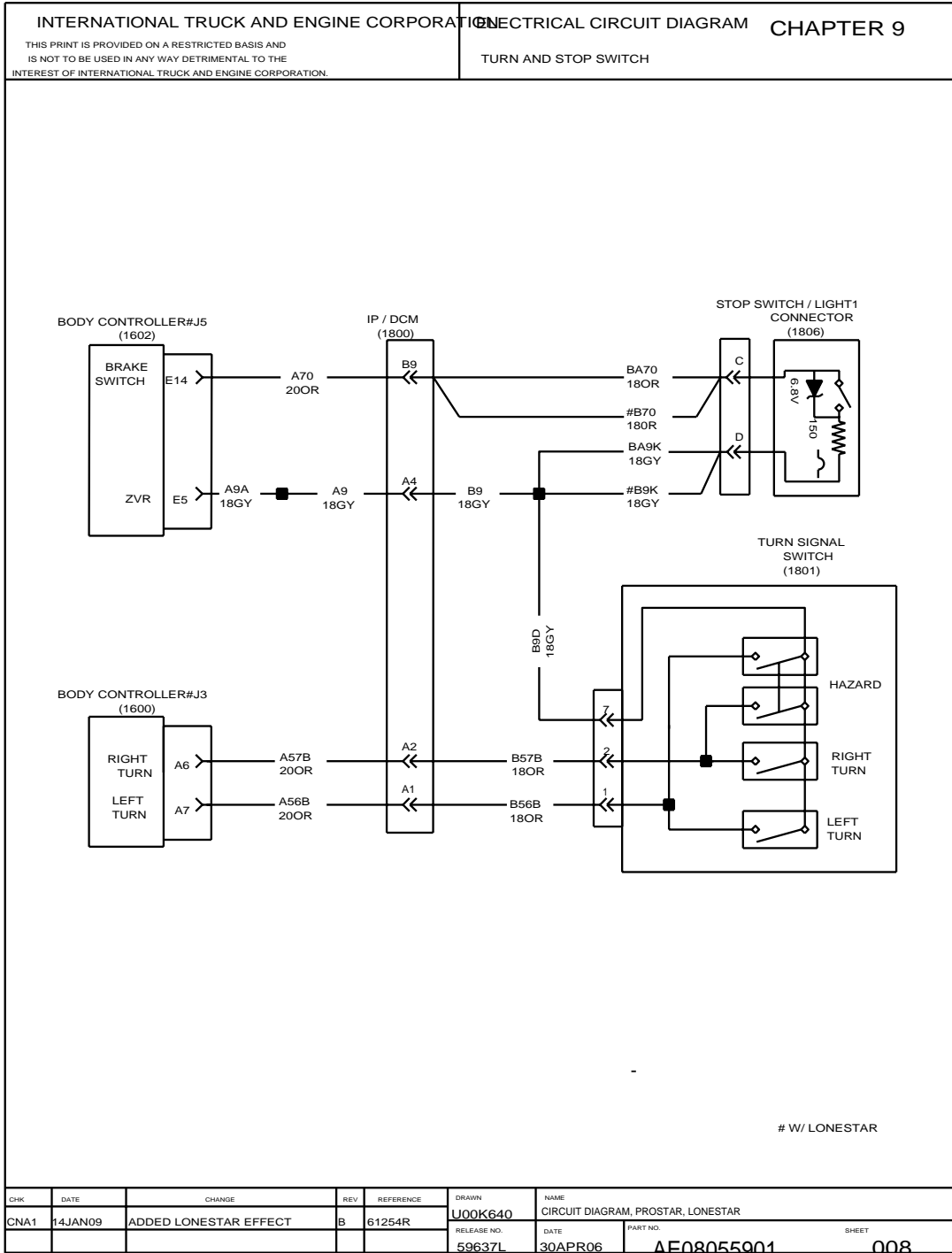


Figure 156 Turn and Stop Switch

9.11. LIGHT SYSTEM — PARK, MARKER, CLEARANCE, ID, TURN, STOP, TAIL, P. 9

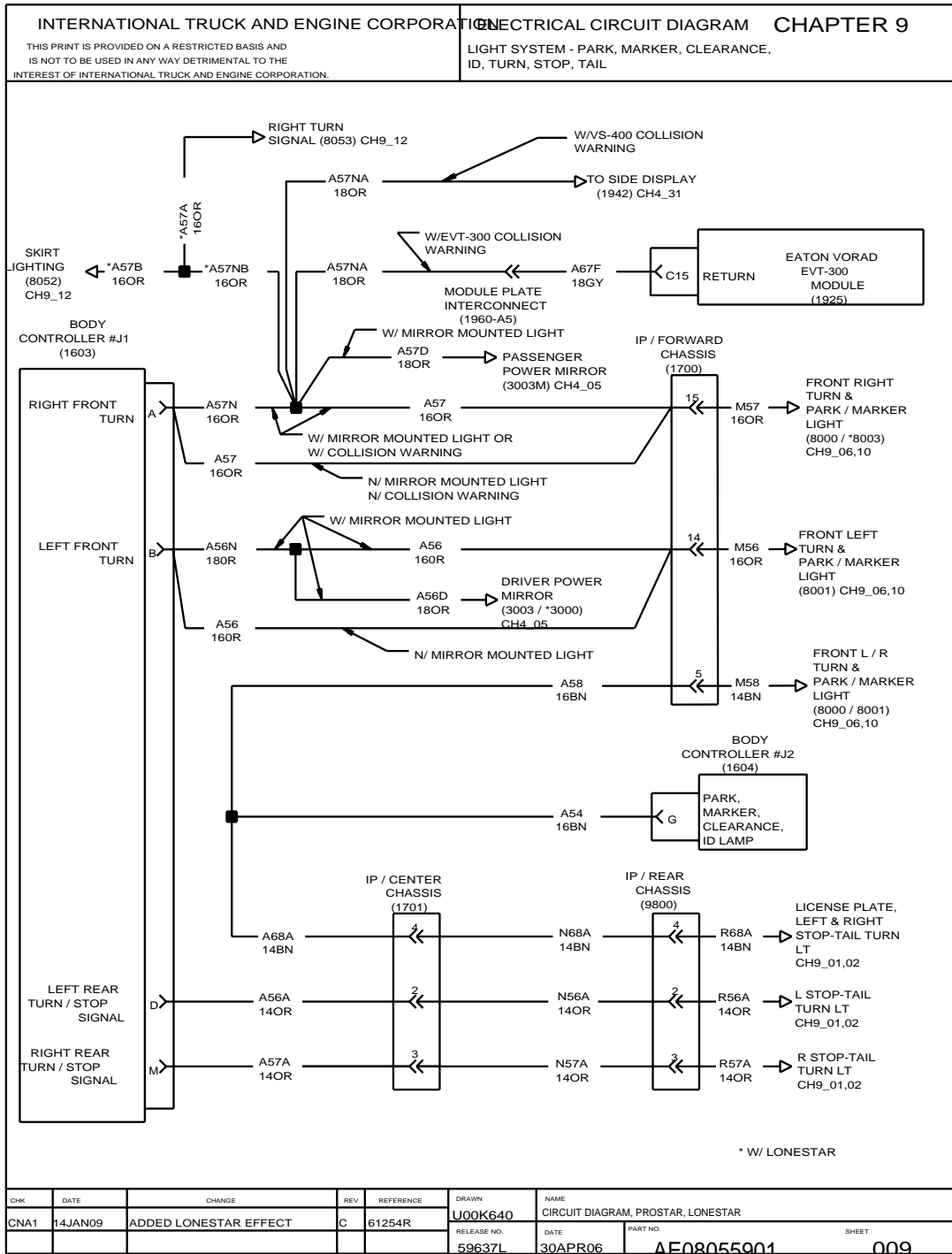


Figure 157 Light System — Park, Marker, Clearance, ID, Turn, Stop, Tail

9.12. LIGHT SYSTEM — PARK, MARKER, FRONT TURN AND MODESTY PANEL LIGHT, P. 10

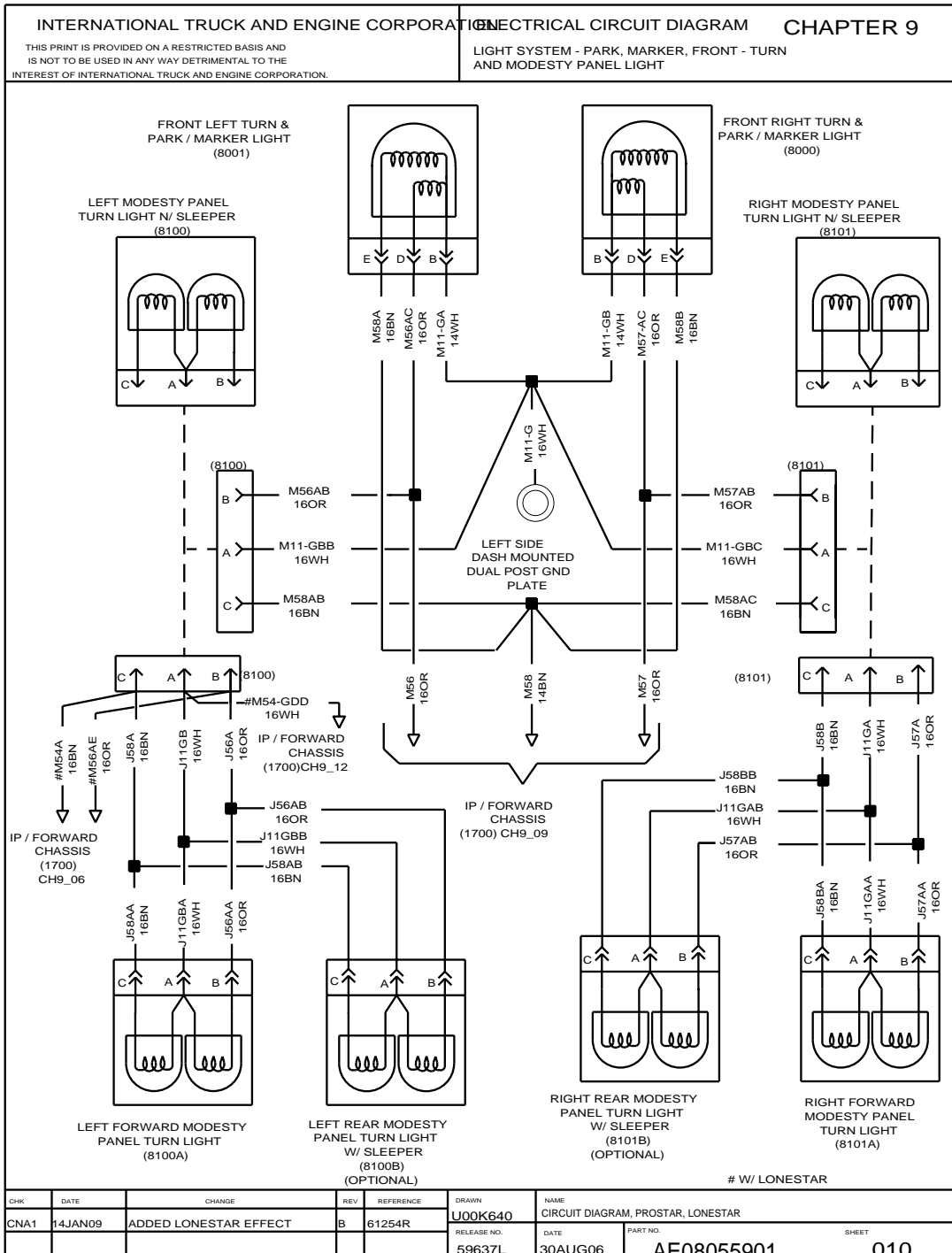


Figure 158 Light System — Park, Marker, Front Turn and Modesty Panel Light

9.13. LIGHT SYSTEM — CLEARANCE, ID, P. 11

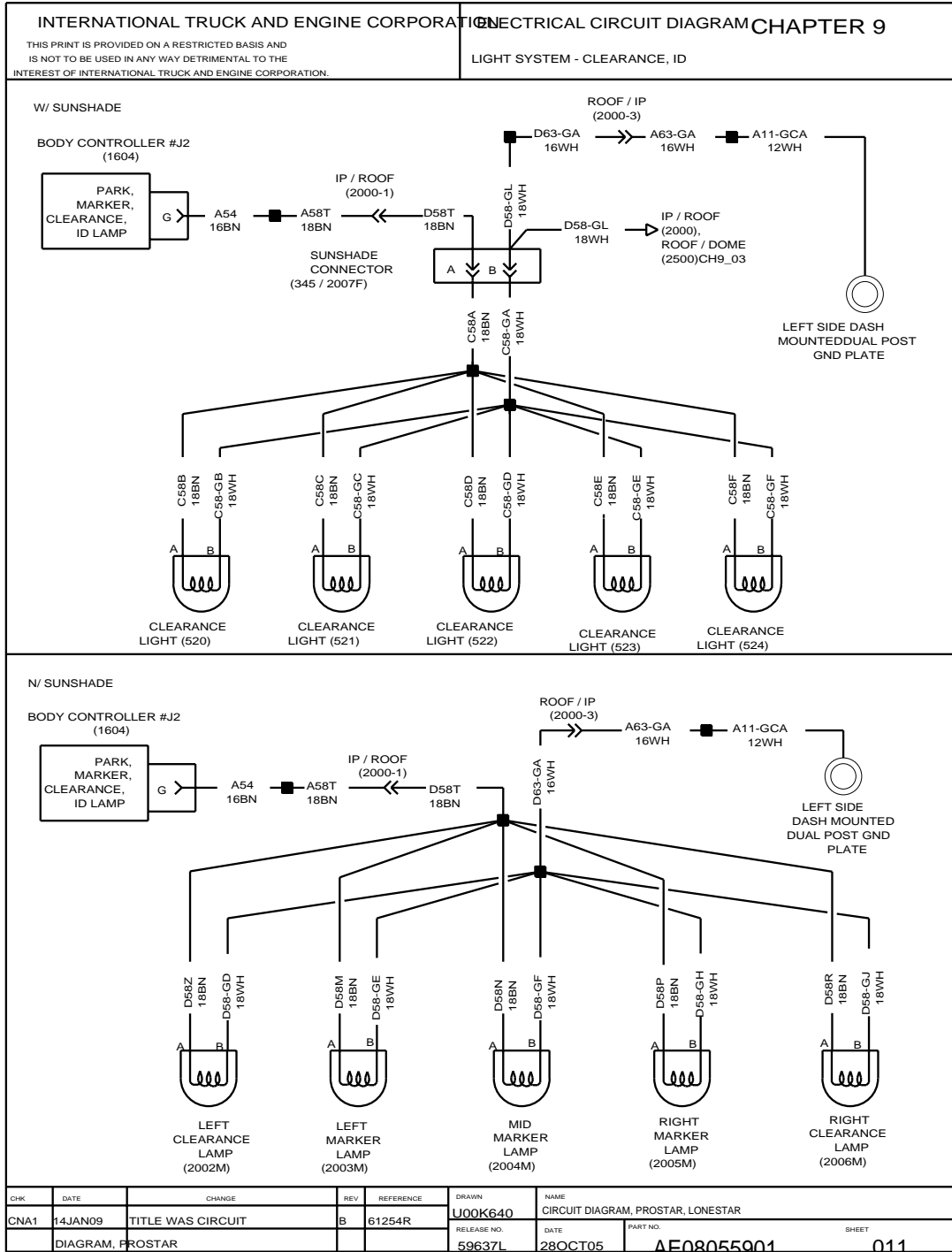


Figure 159 Light System — Clearance, ID

9.14. LIGHT SYSTEM — SKIRT LIGHT, P. 12

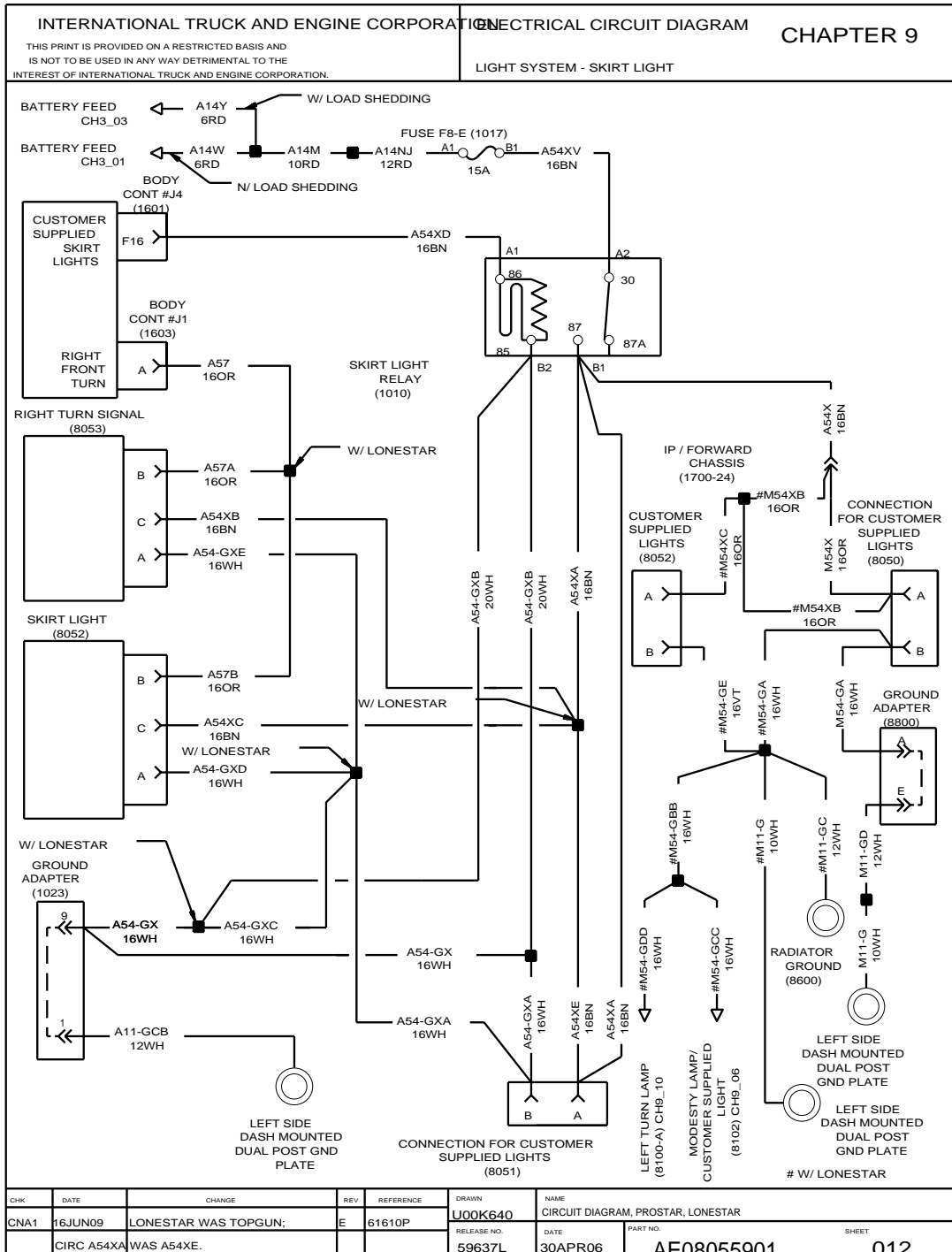


Figure 160 Light System — Skirt Light

9.15. TRAILER LIGHT SYSTEM — MARKER, STOP, TAIL, TURN, P. 13

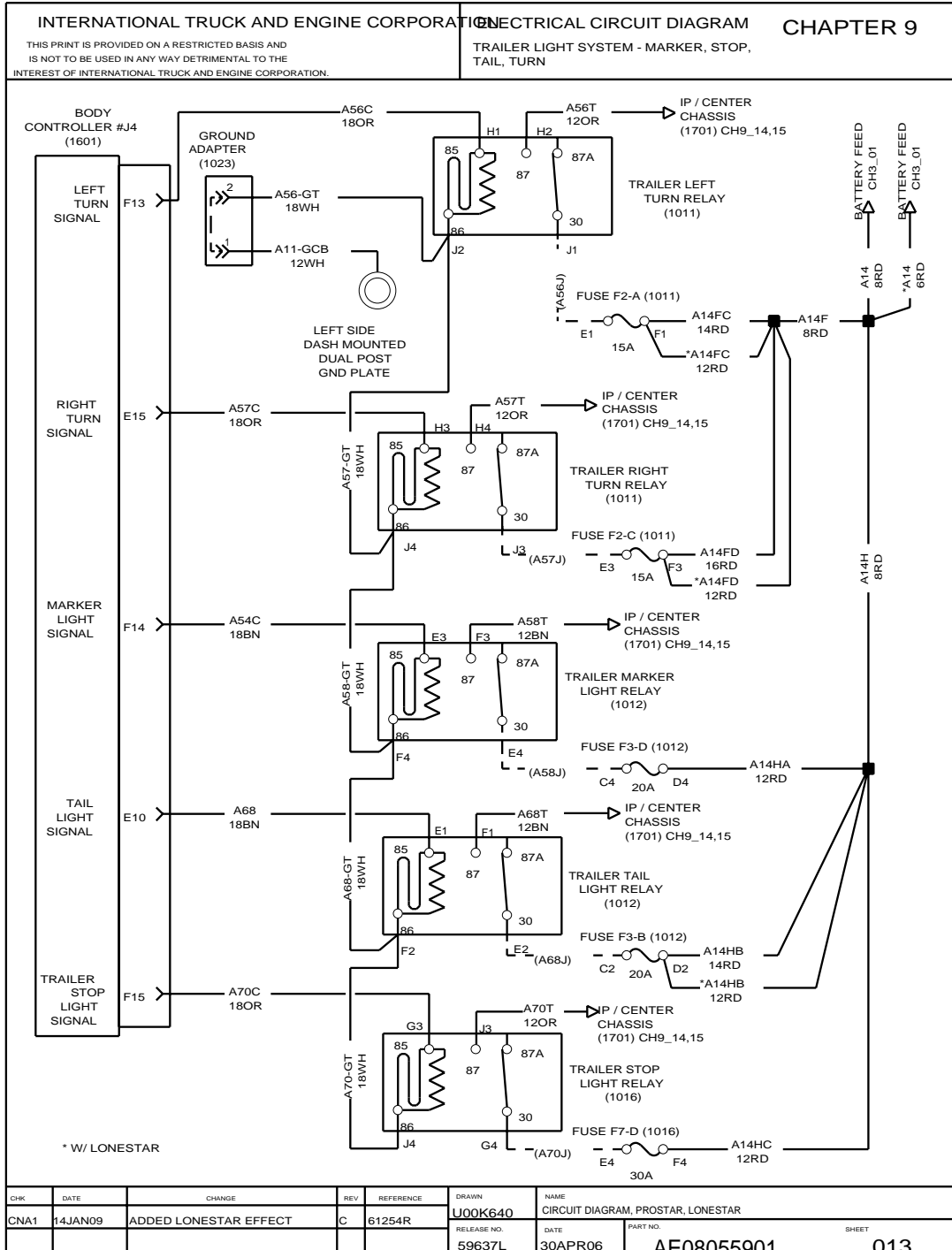


Figure 161 Trailer Light System — Marker, Stop, Tail, Turn

9.16. TRAILER SOCKET — BOC, P. 14

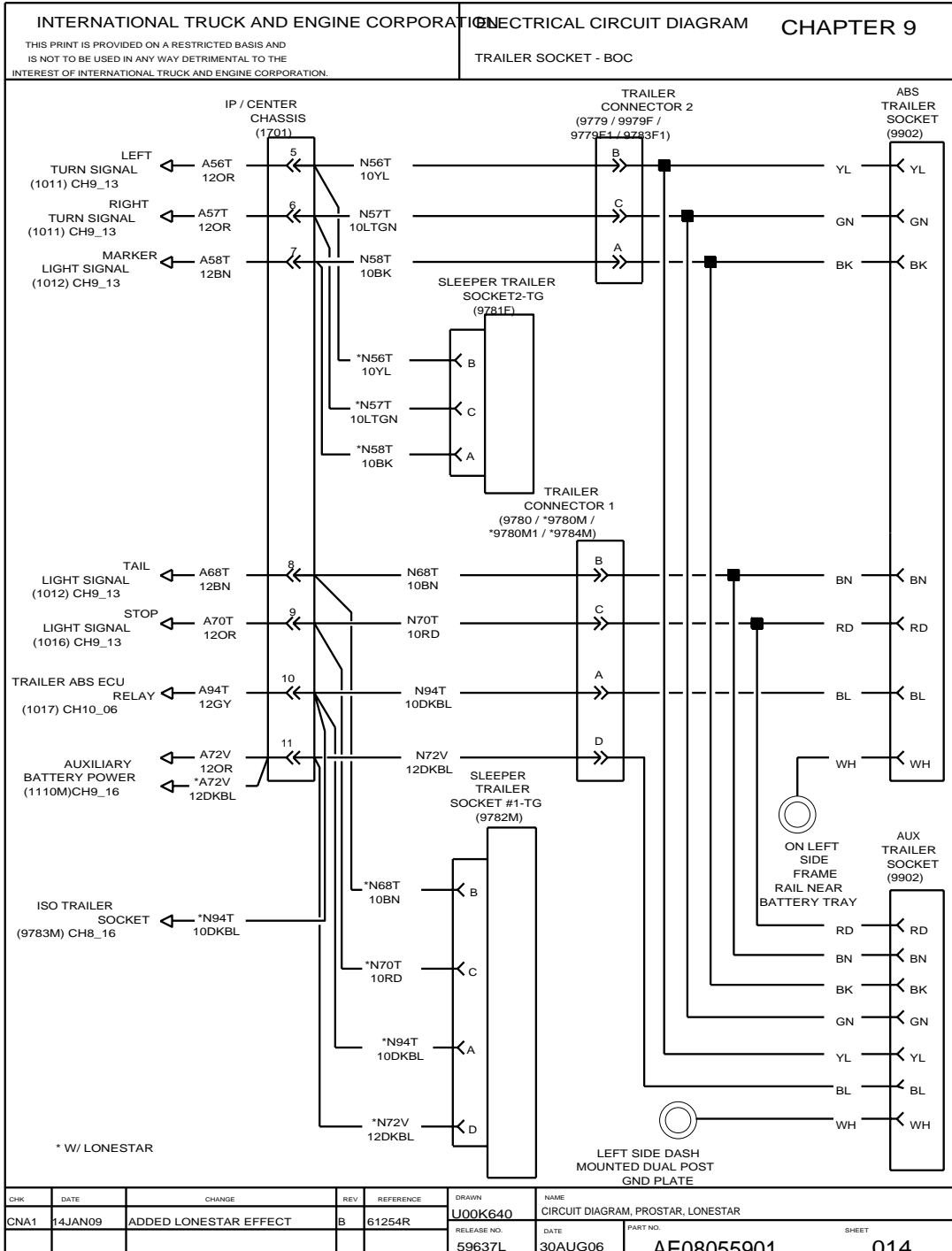


Figure 162 Trailer Socket — BOC

9.17. TRAILER SOCKET — BOC AND EOF, P. 15

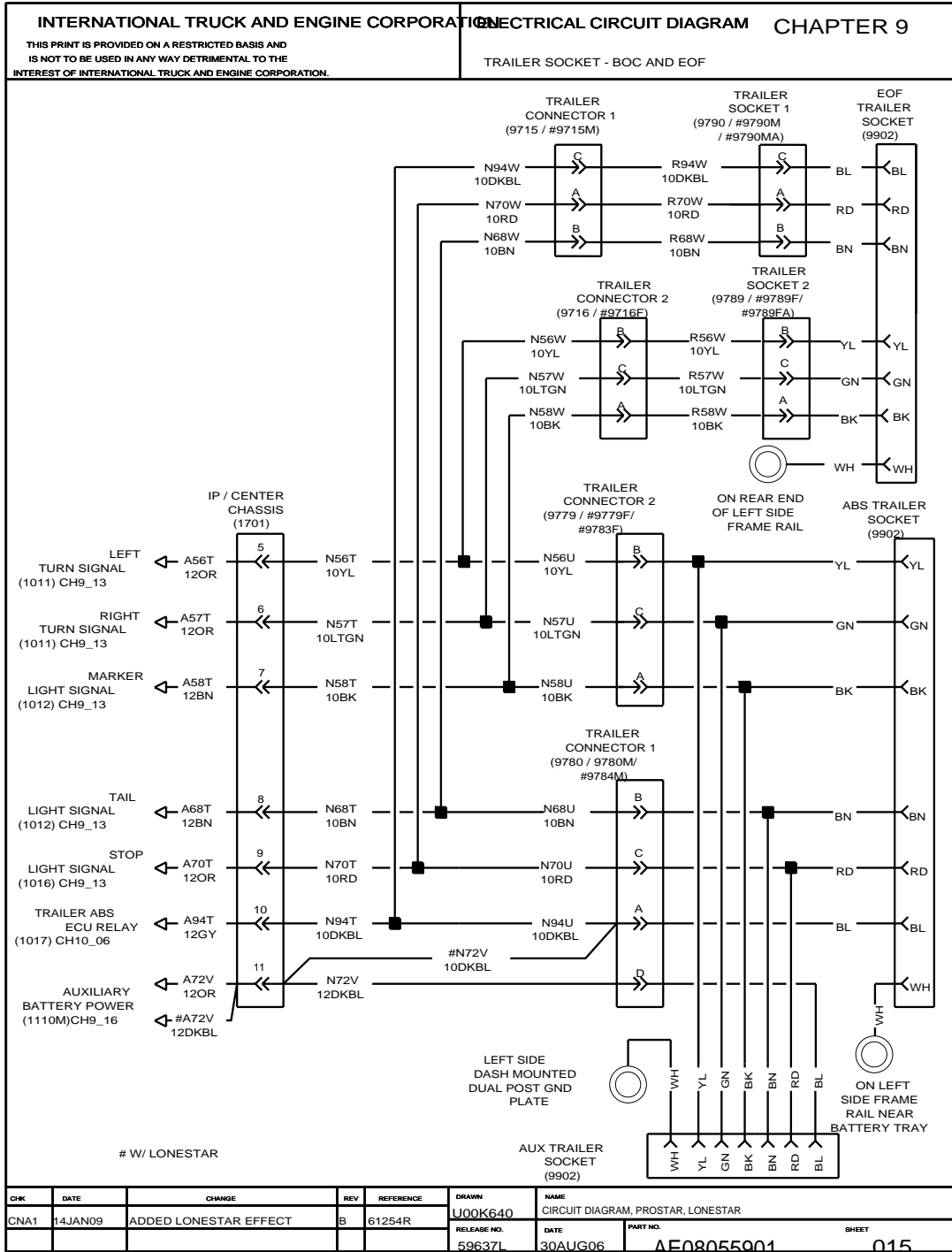


Figure 163 Trailer Socket — BOC and EOF

9.18. TRAILER SOCKET — AUXILIARY, P. 16

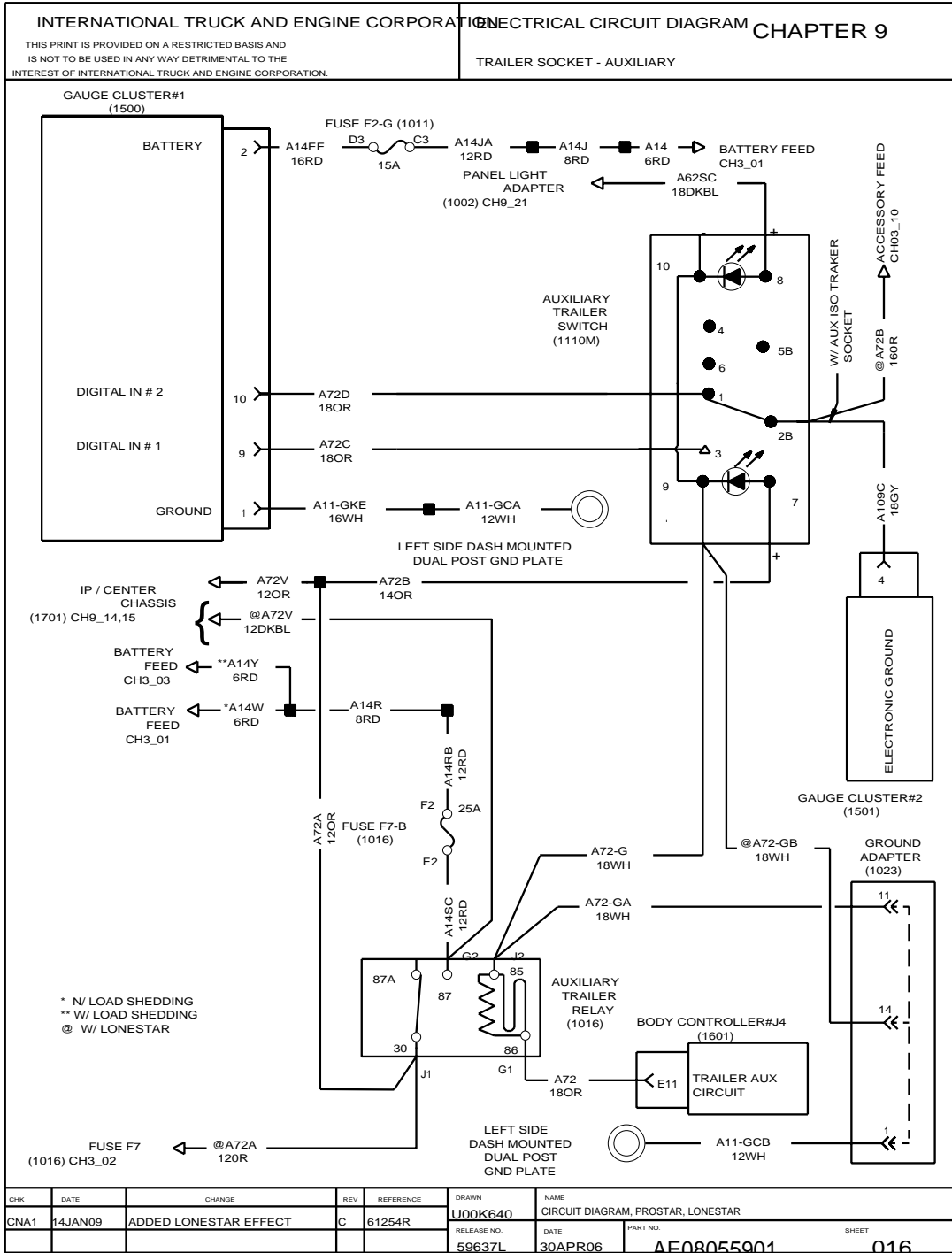


Figure 164 Trailer Socket — Auxiliary

9.19. FLOOR LIGHT, P. 17

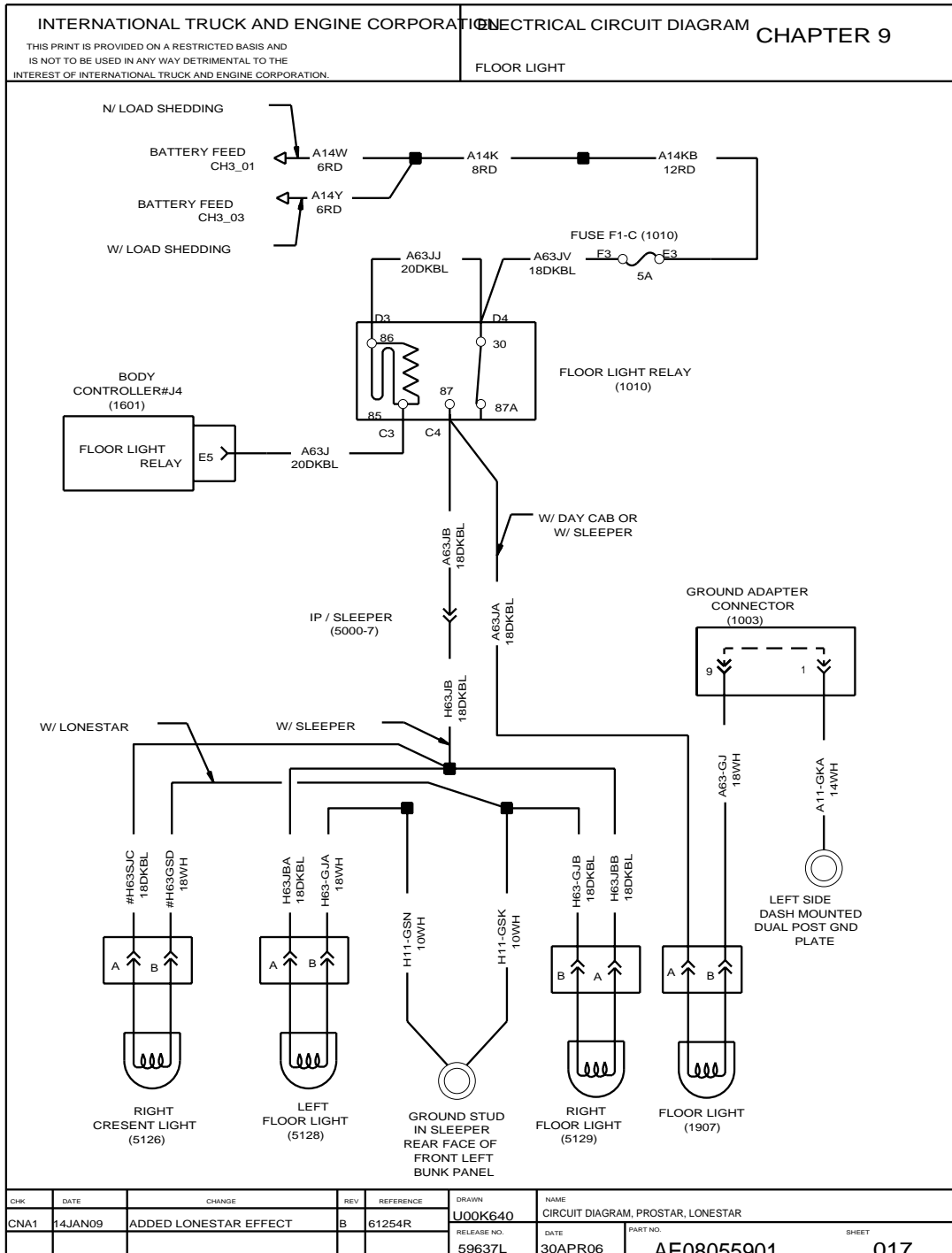


Figure 165 Floor Light

9.20. DOME AND ACCENT LIGHT — SLEEPER, P. 18

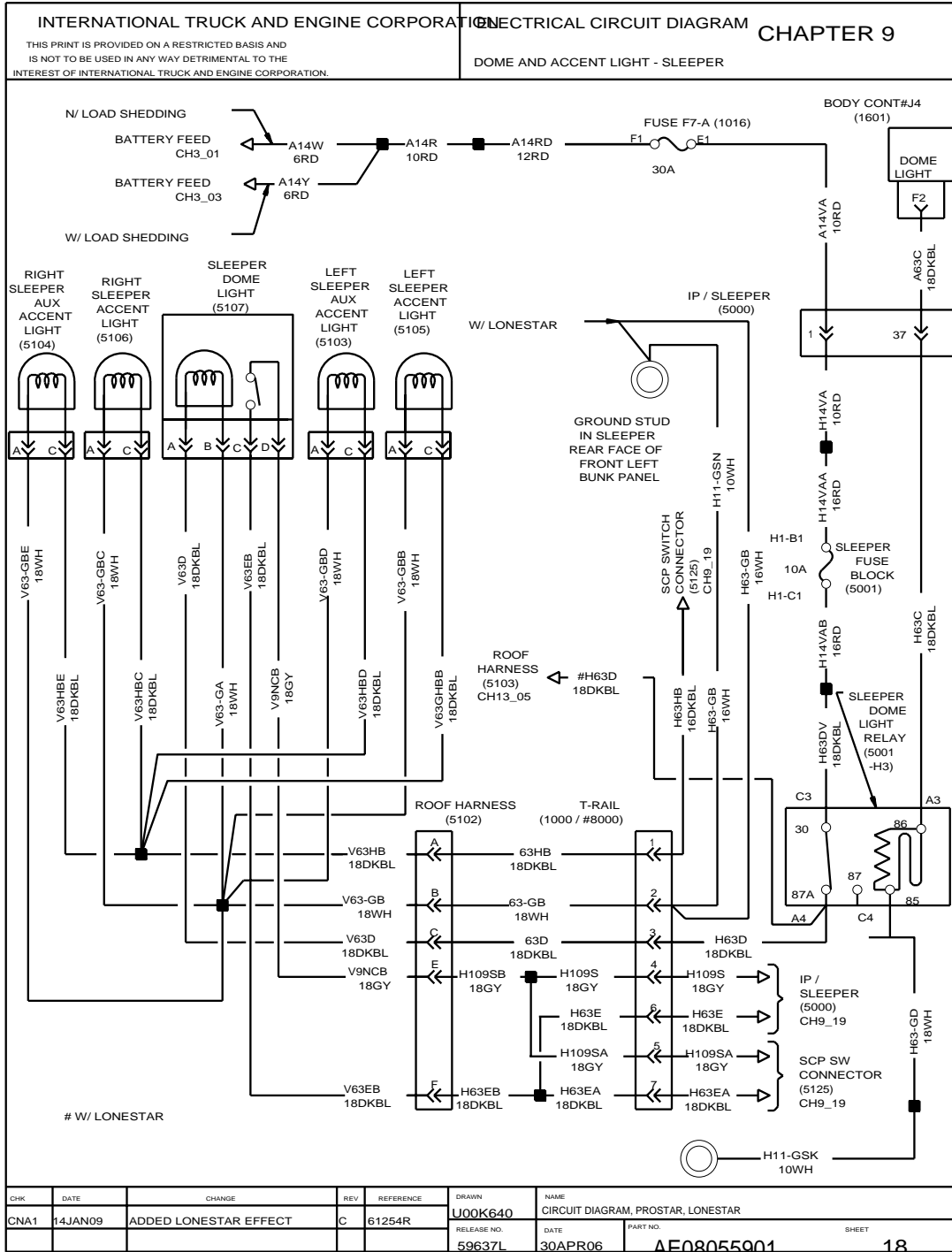


Figure 166 Dome and Accent Light — Sleeper

9.21. DOME AND ACCENT LIGHT — SLEEPER, P. 19

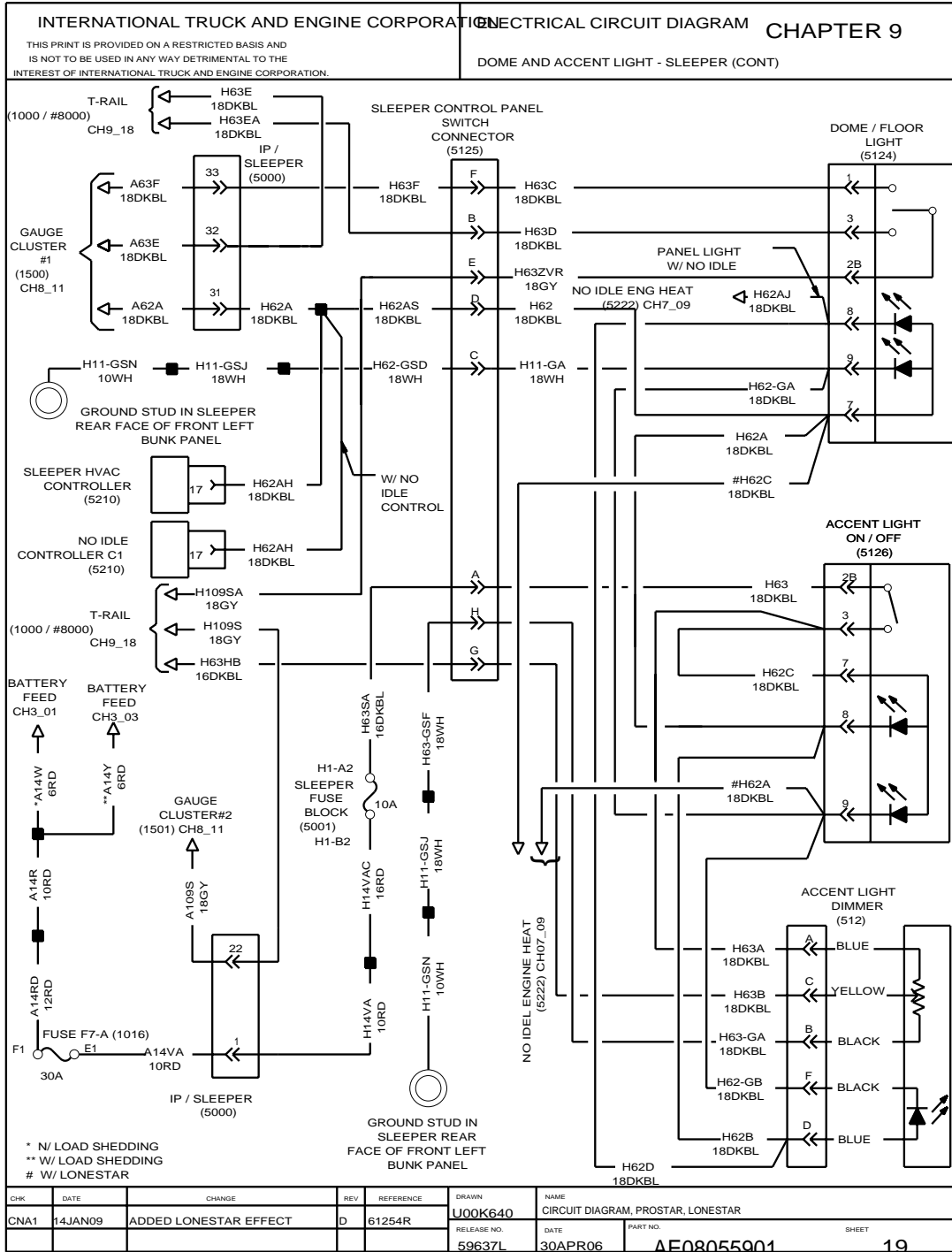


Figure 167 Dome and Accent Light — Sleeper

9.22. LIGHTED AIR SHIELD, P. 20

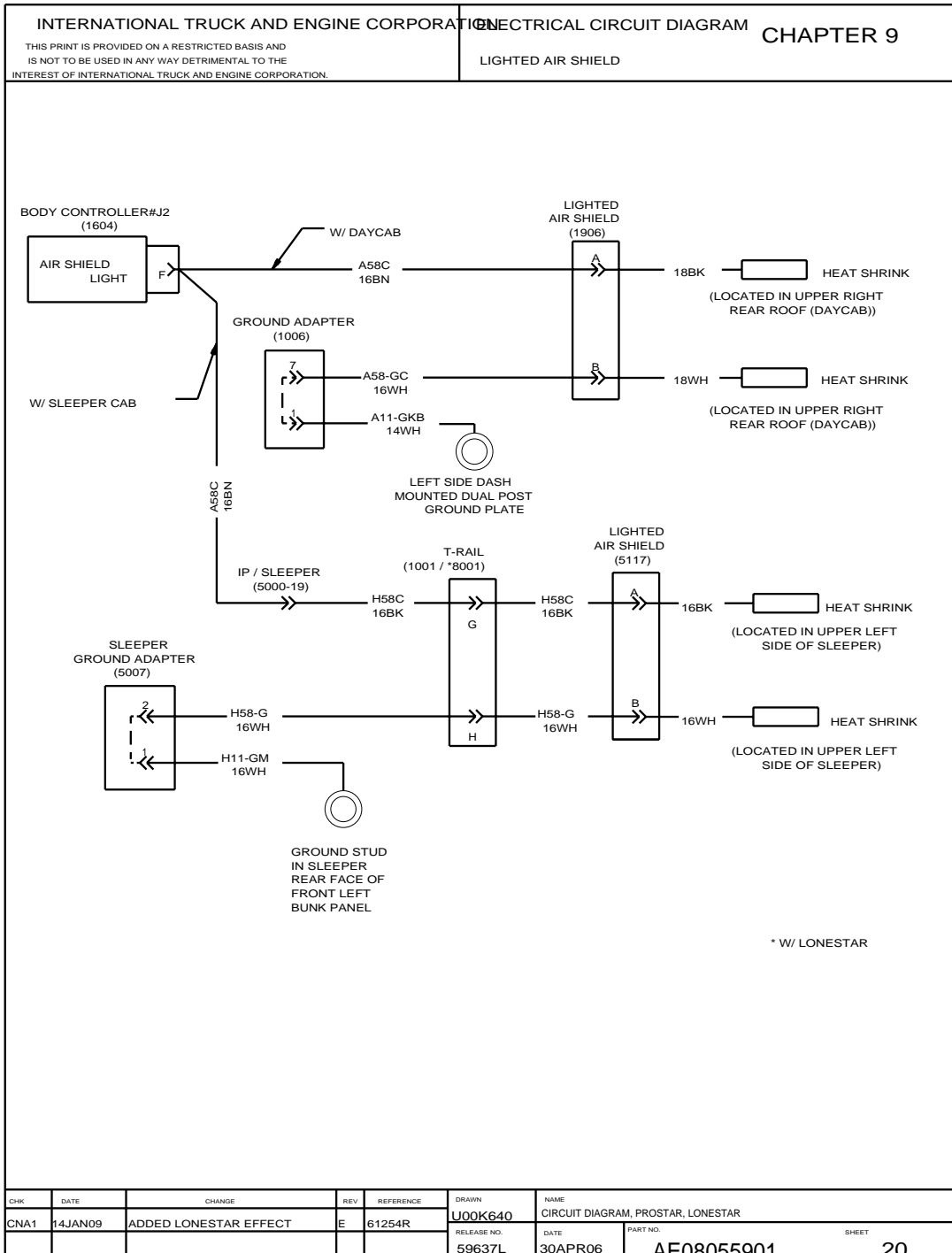


Figure 168 Lighted Air Shield

9.23. PANEL LIGHTS, P. 21

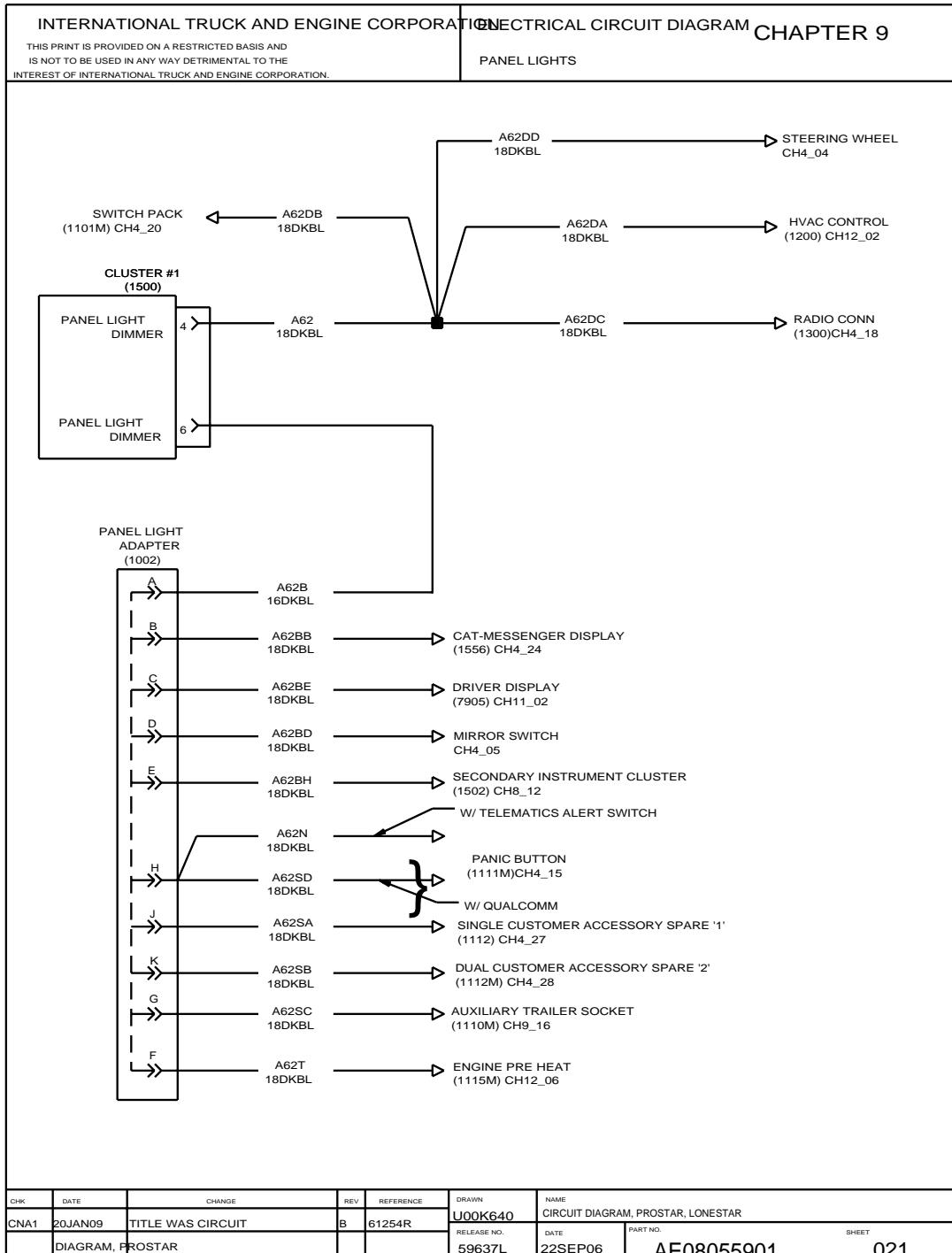


Figure 169 Panel Lights

9.24. WORK LIGHTS — DAY CAB, P. 22

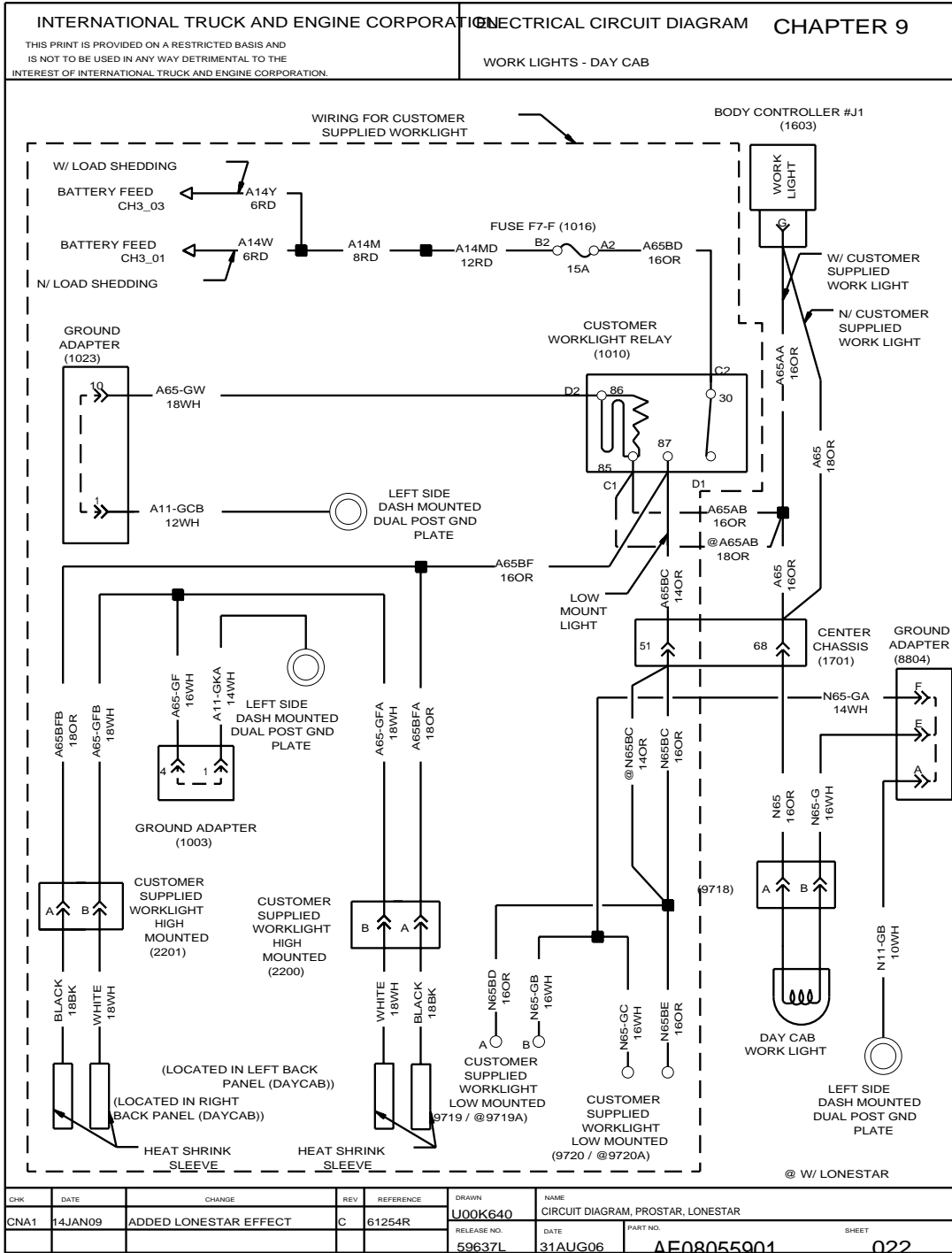


Figure 170 Work Lights — Day Cab

9.25. WORK LIGHTS — SLEEPER CAB, P. 23

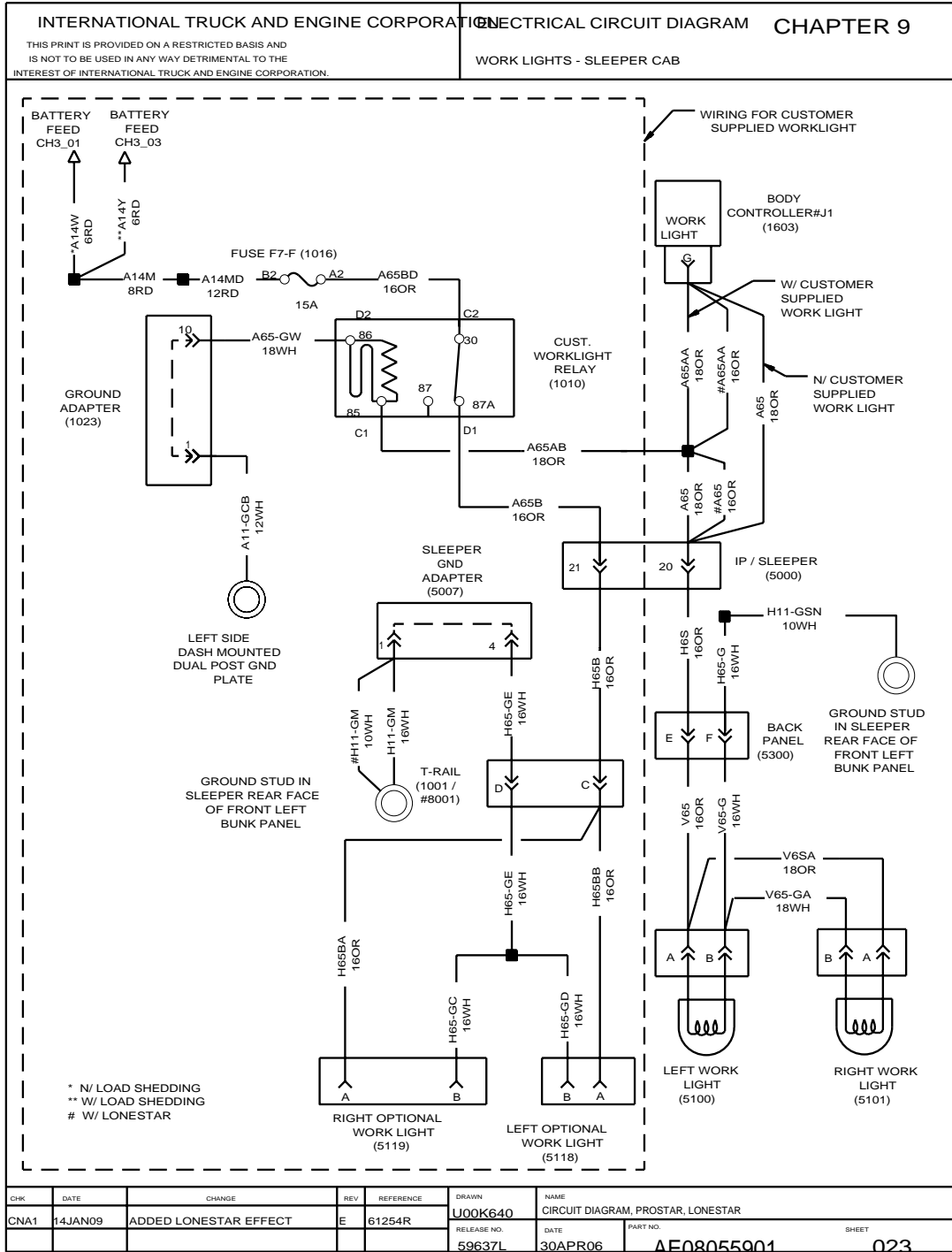


Figure 171 Work Lights — Sleeper Cab

9.26. DOME AND ACCENT LIGHTS — SLEEPER, P. 24

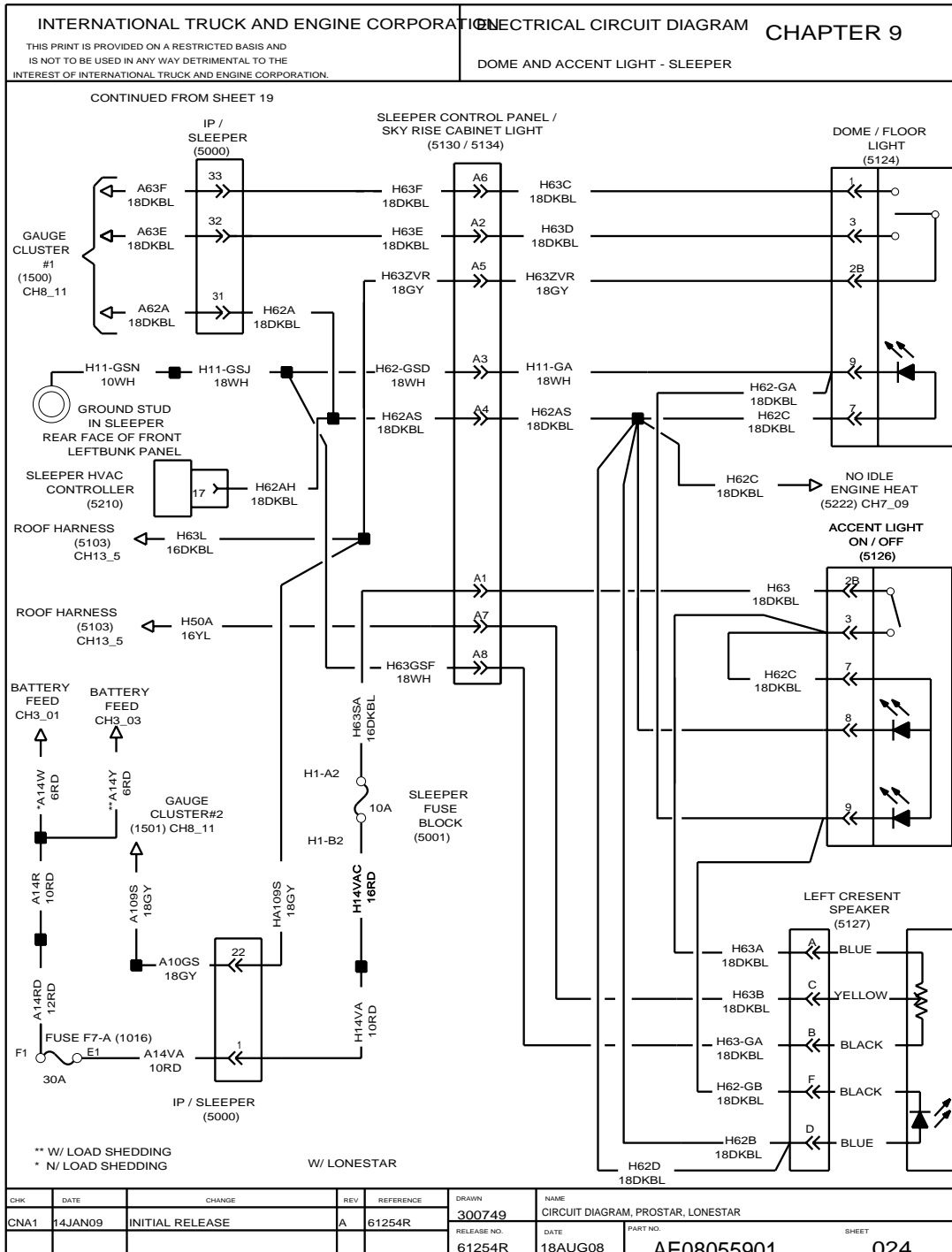


Figure 172 Dome and Accent Lights — Sleeper

## 10. CHASSIS ACCESSORIES (CHAPTER 10)

### 10.1. TIRE PRESSURE MONITOR, P. 1

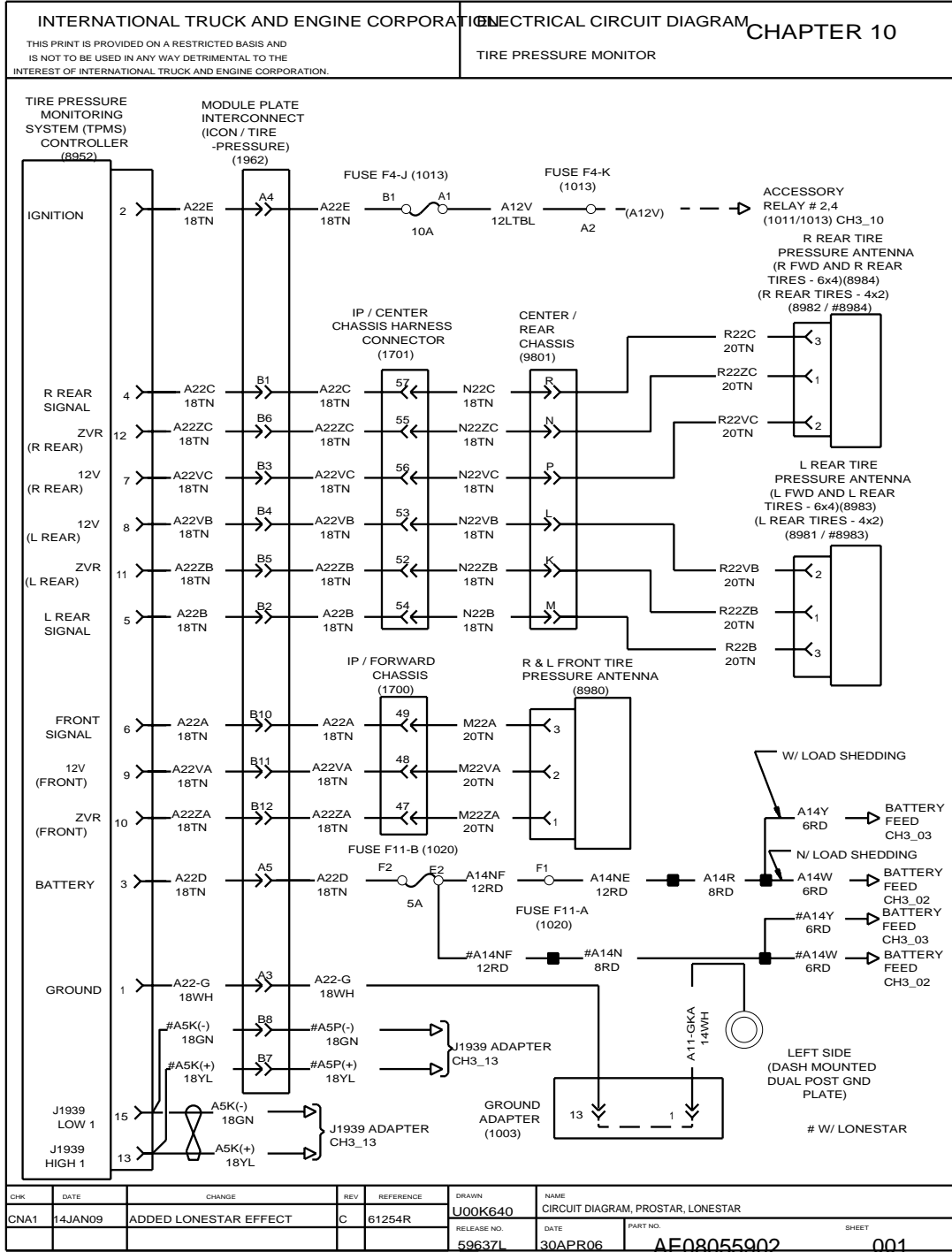


Figure 173 Tire Pressure Monitor

10.2. AIR DRYER, P. 2

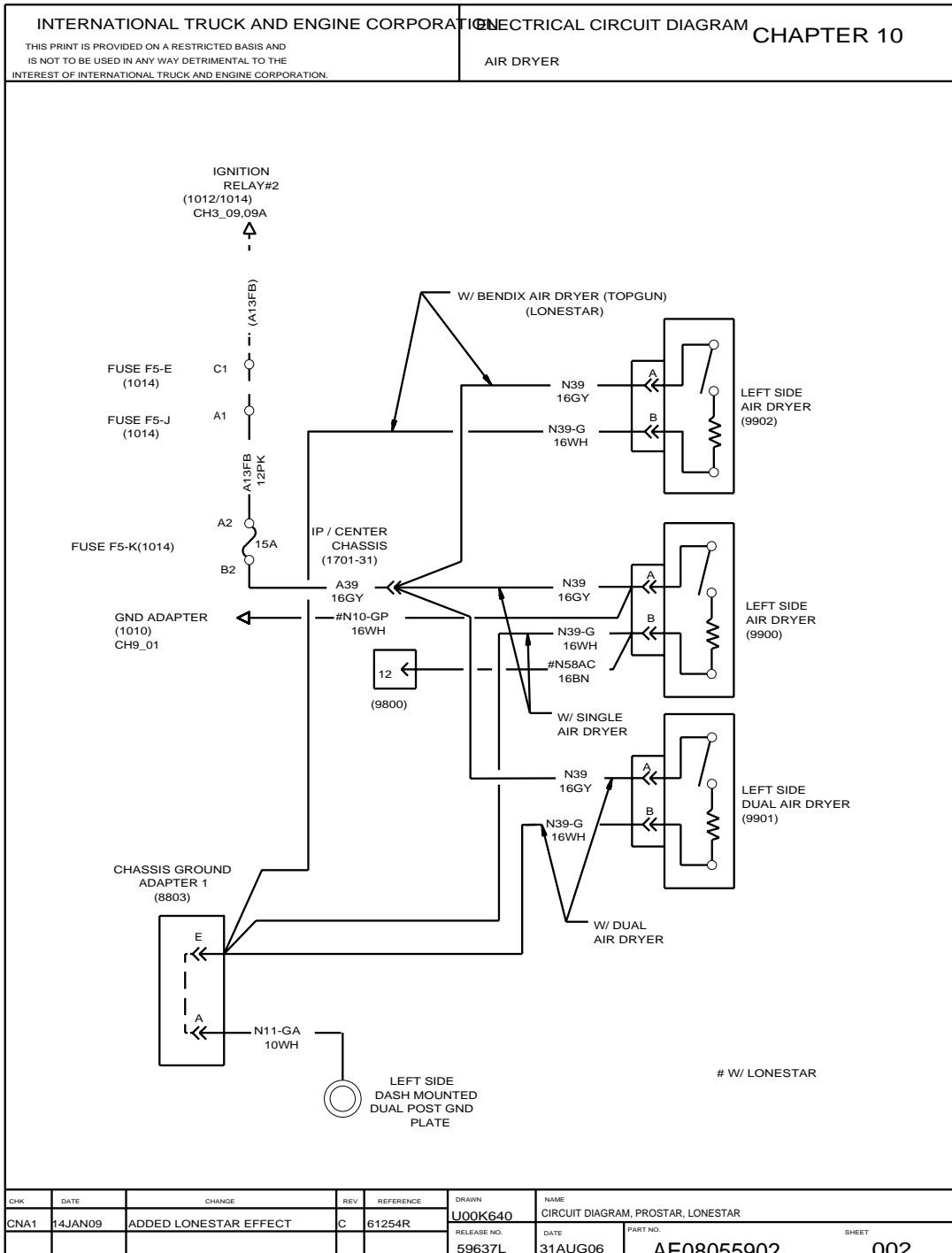


Figure 174 Air Dryer

10.3. AIR SOLENOID PACK — 4 WAY, P. 3

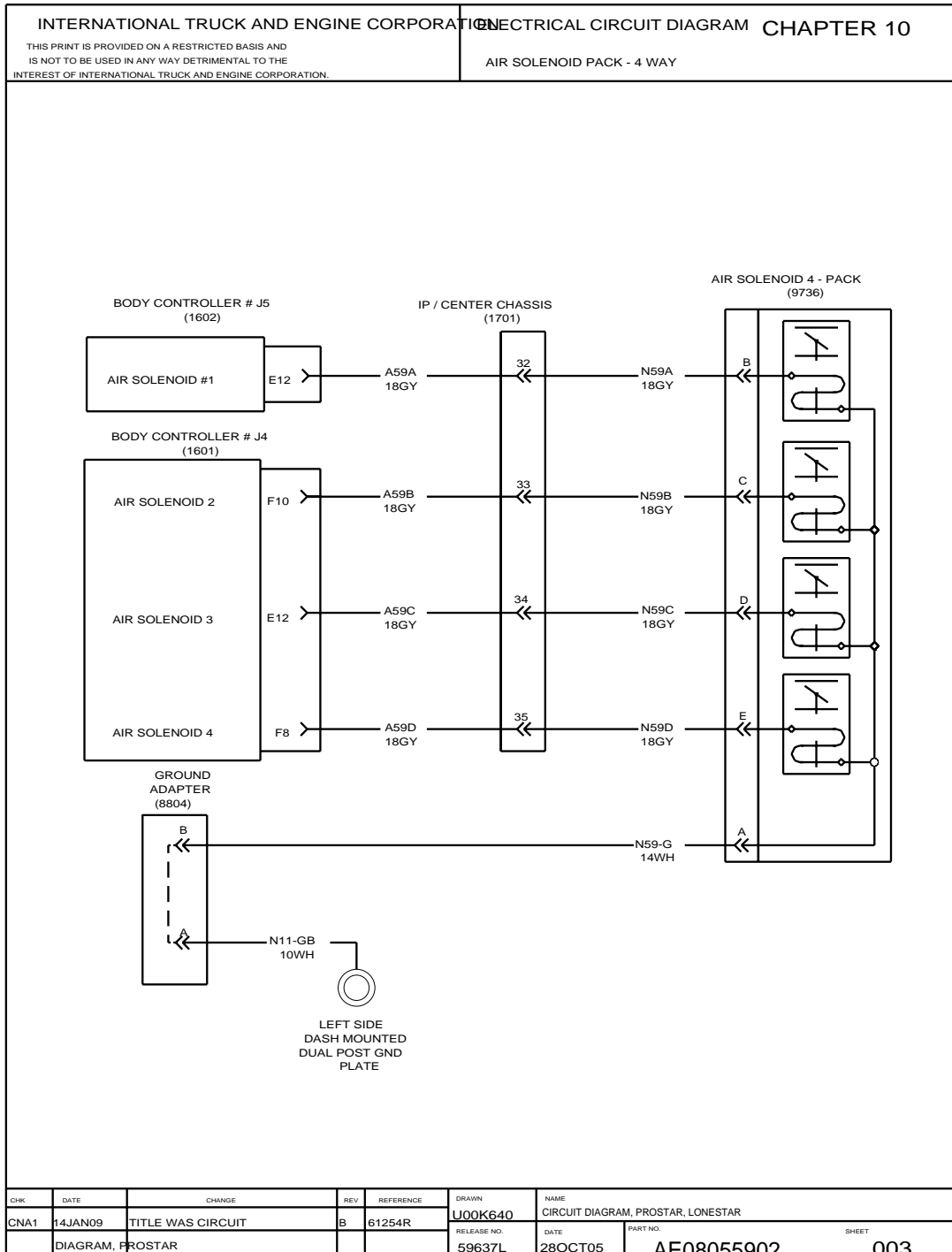


Figure 175 Air Solenoid Pack — 4 Way

CHK	DATE	CHANGE	REV	REFERENCE	DRAWN	NAME
CNA1	14JAN09	TITLE WAS CIRCUIT	B	61254R	U00K640	CIRCUIT DIAGRAM, PROSTAR, LONESTAR
		DIAGRAM, PROSTAR			59637L	DATE: 28OCT05 PART NO: AE08055902 SHEET: 003

10.4. AIR SOLENOID PACK — 4 WAY, P. 4

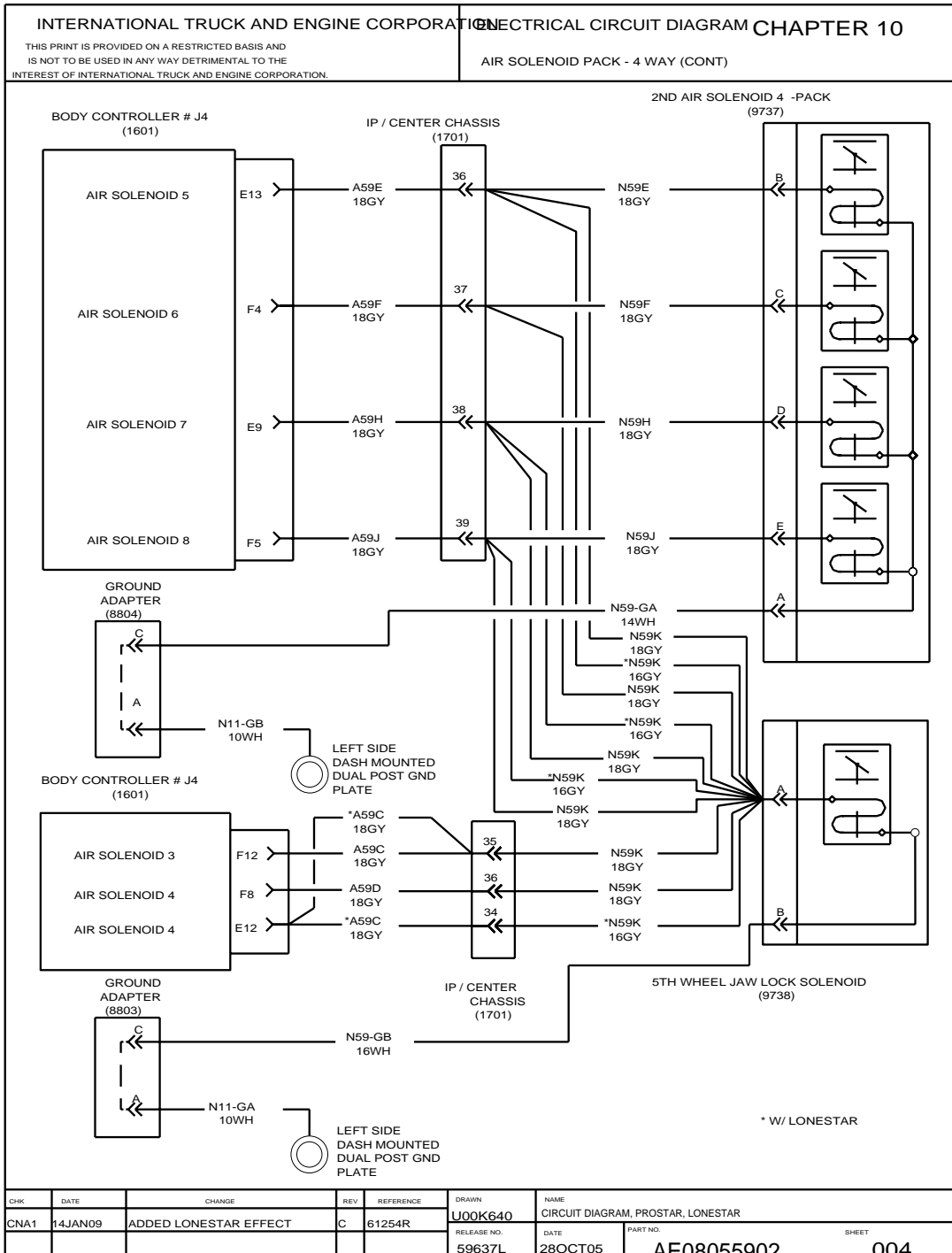


Figure 176 Air Solenoid Pack — 4 Way

10.5. AIR SUSPENSION W/LOAD INDICATOR, P. 5

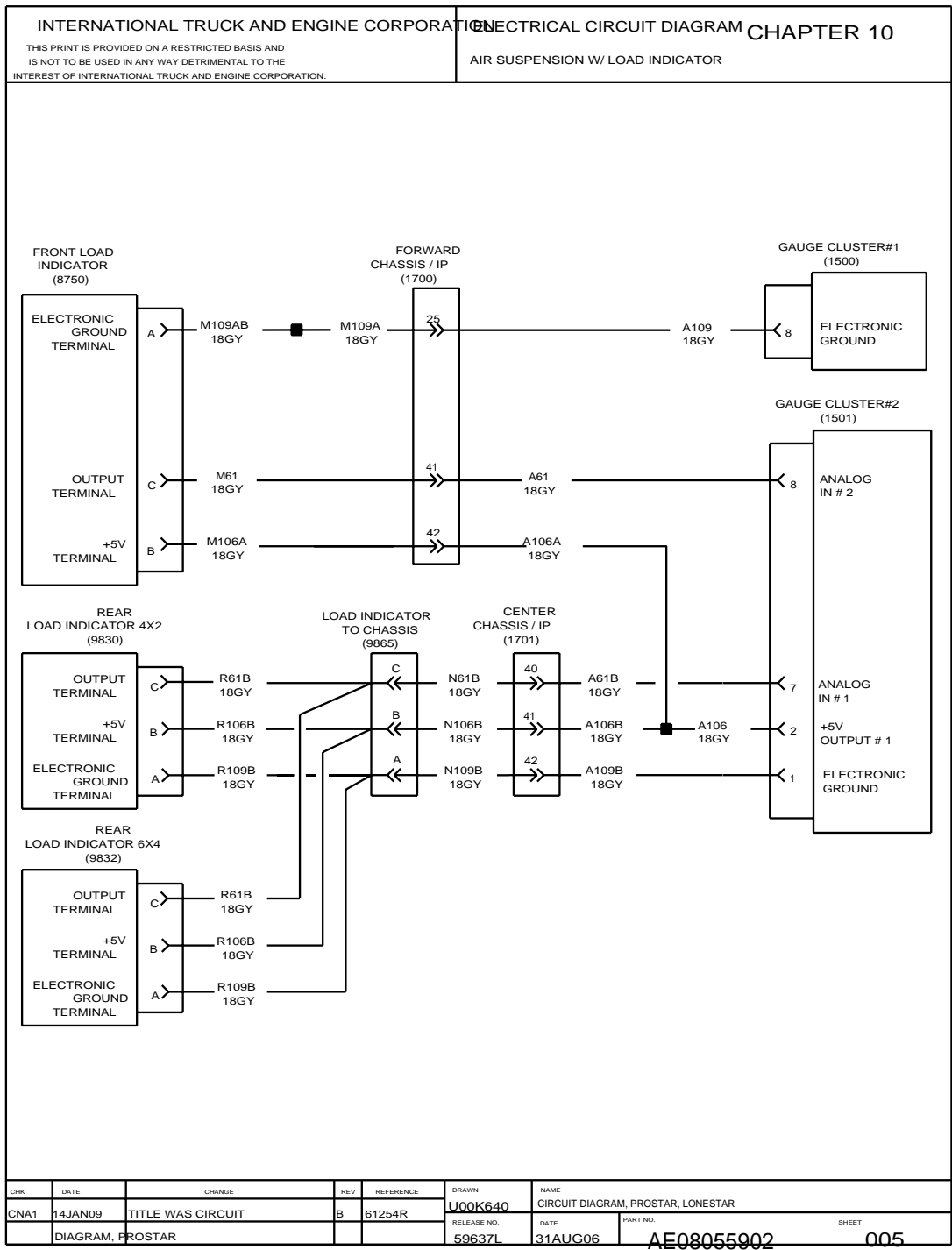


Figure 177 Air Suspension With Load Indicator

10.6. BATTERY FEED — TRAILER AUXILIARY, P. 6

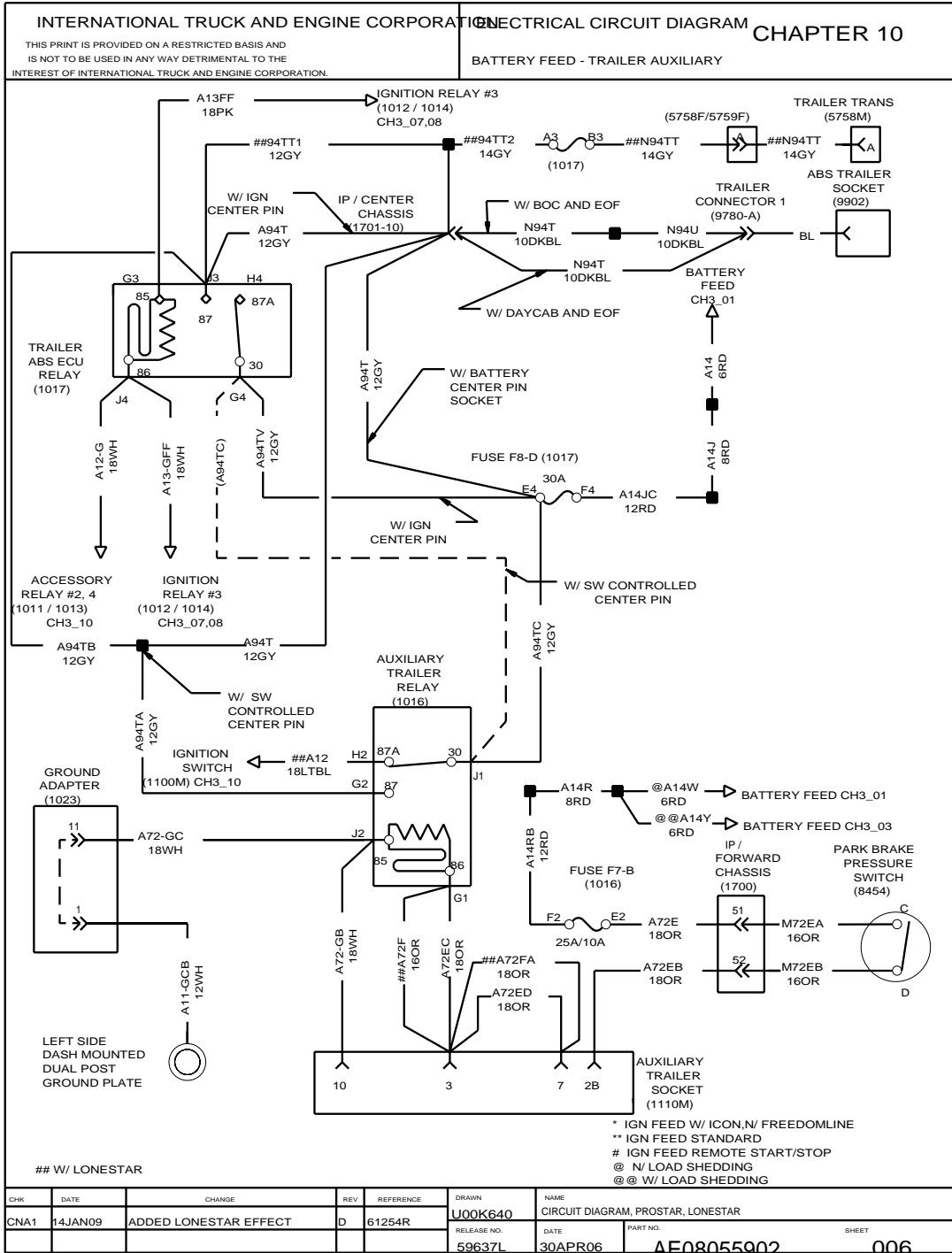


Figure 178 Battery Feed — Trailer Auxiliary

10.7. ANTILOCK BRAKE SYSTEM W/BENDIX, P. 7

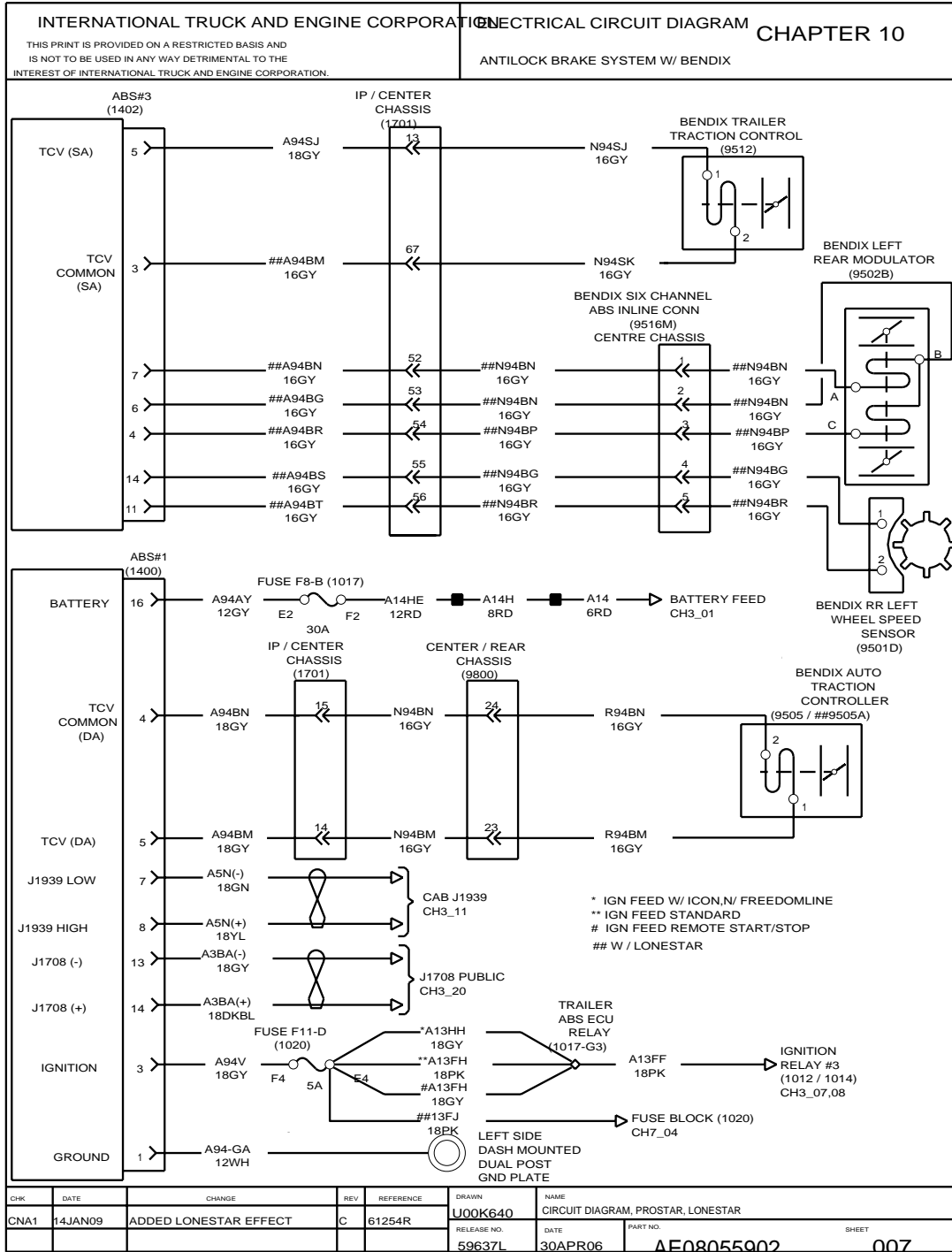


Figure 179 Antilock Brake System W/Bendix

10.8. ANTILOCK BRAKE SYSTEM W/BENDIX, P. 7A

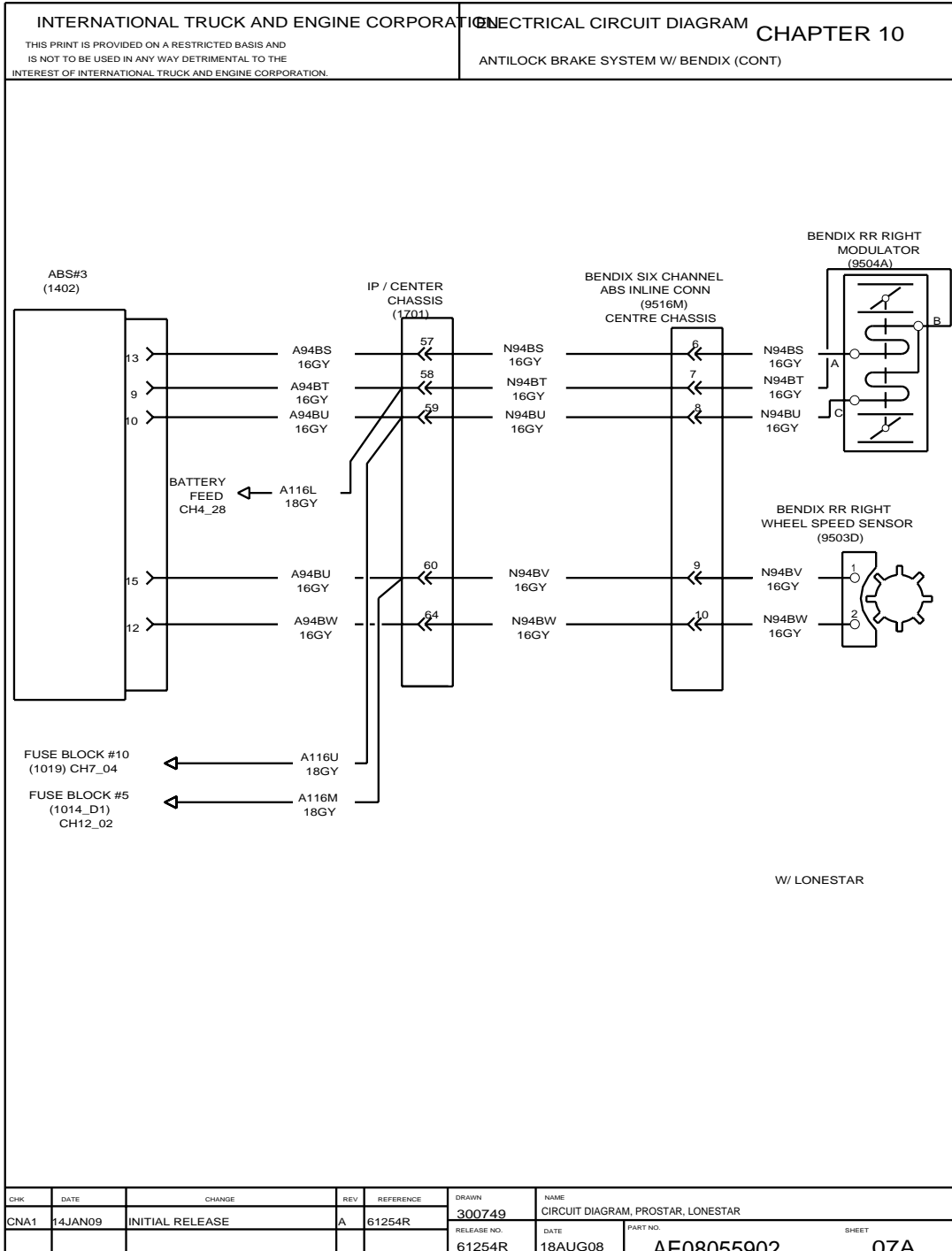


Figure 180 Antilock Brake System W/Bendix

10.9. ANTILOCK BRAKE SYSTEM W/BENDIX, P. 8

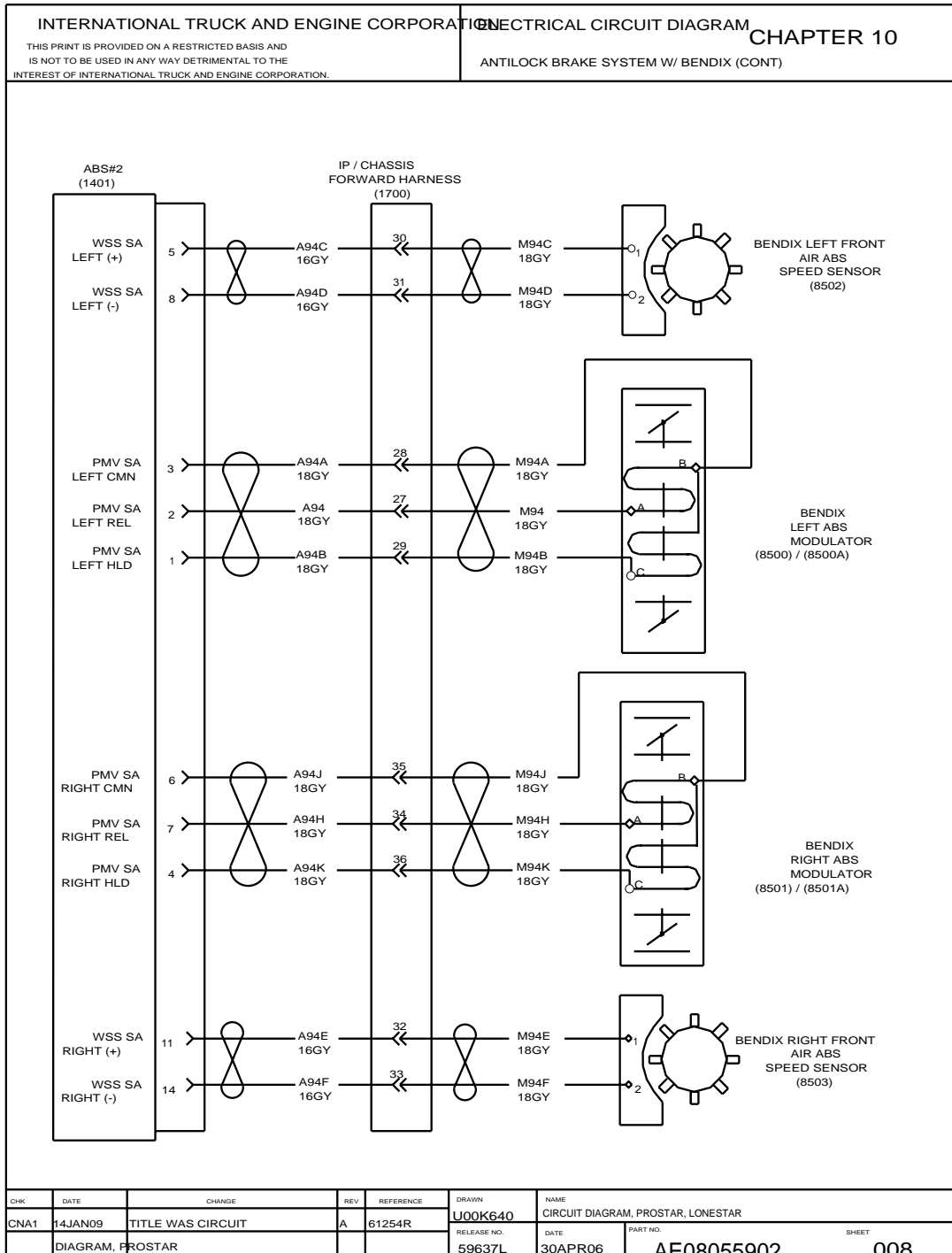


Figure 181 Antilock Brake System W/Bendix

10.10. ANTILOCK BRAKE SYSTEM W/BENDIX, P. 9

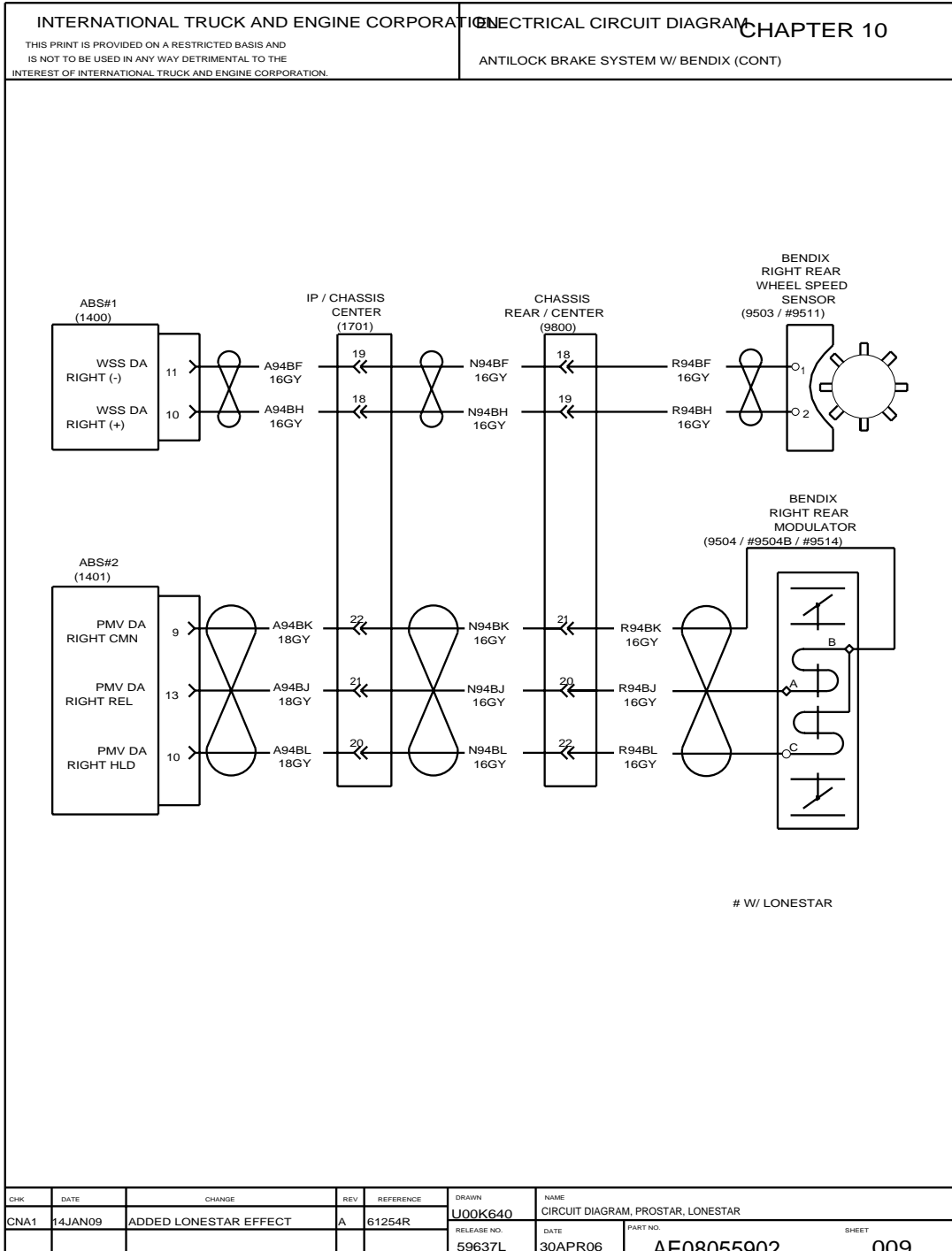


Figure 182 Antilock Brake System W/Bendix

10.11. ANTILOCK BRAKE SYSTEM W/BENDIX, P. 10

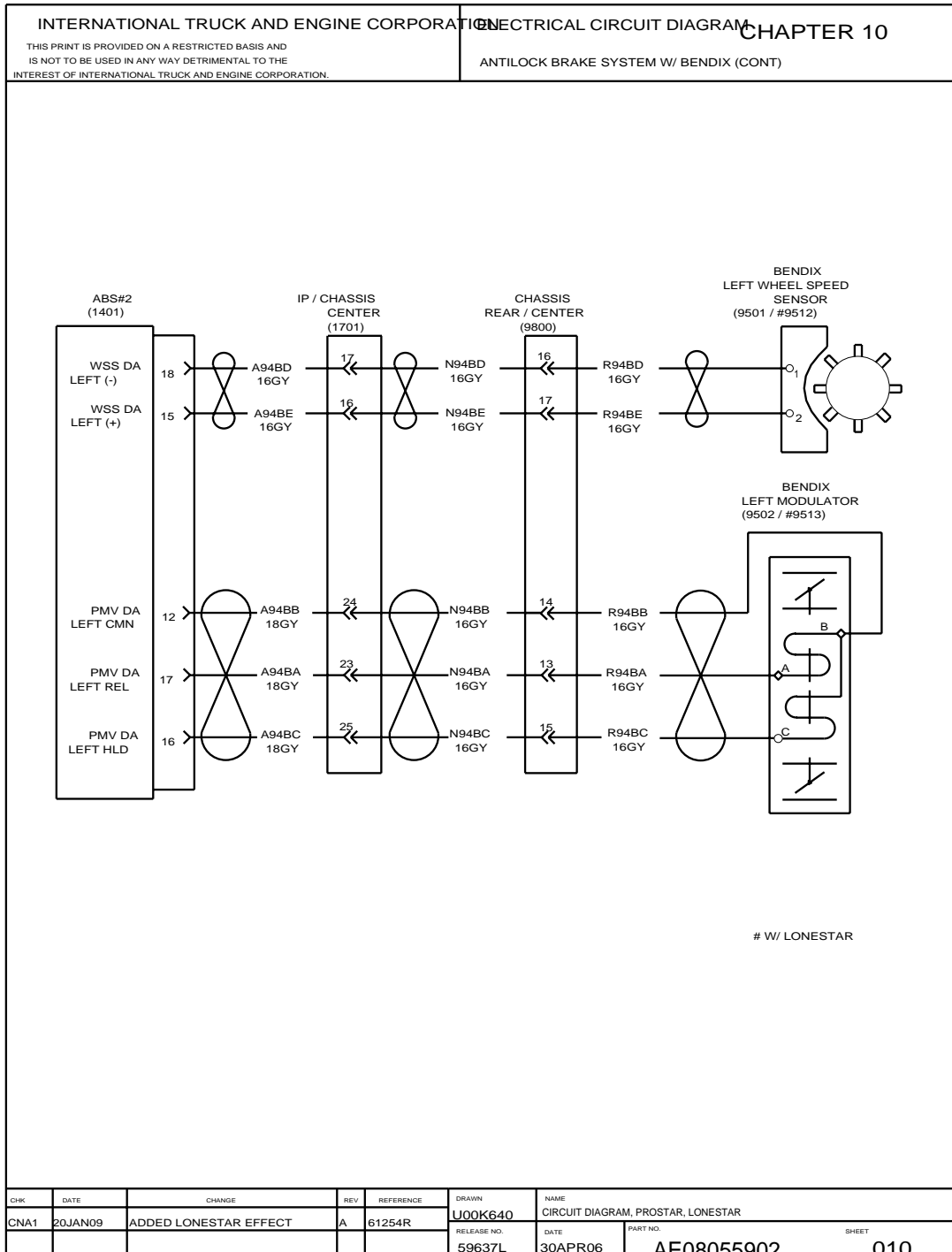


Figure 183 Antilock Brake System W/Bendix

10.12. ANTILOCK BRAKE SYSTEM W/BENDIX, P. 11

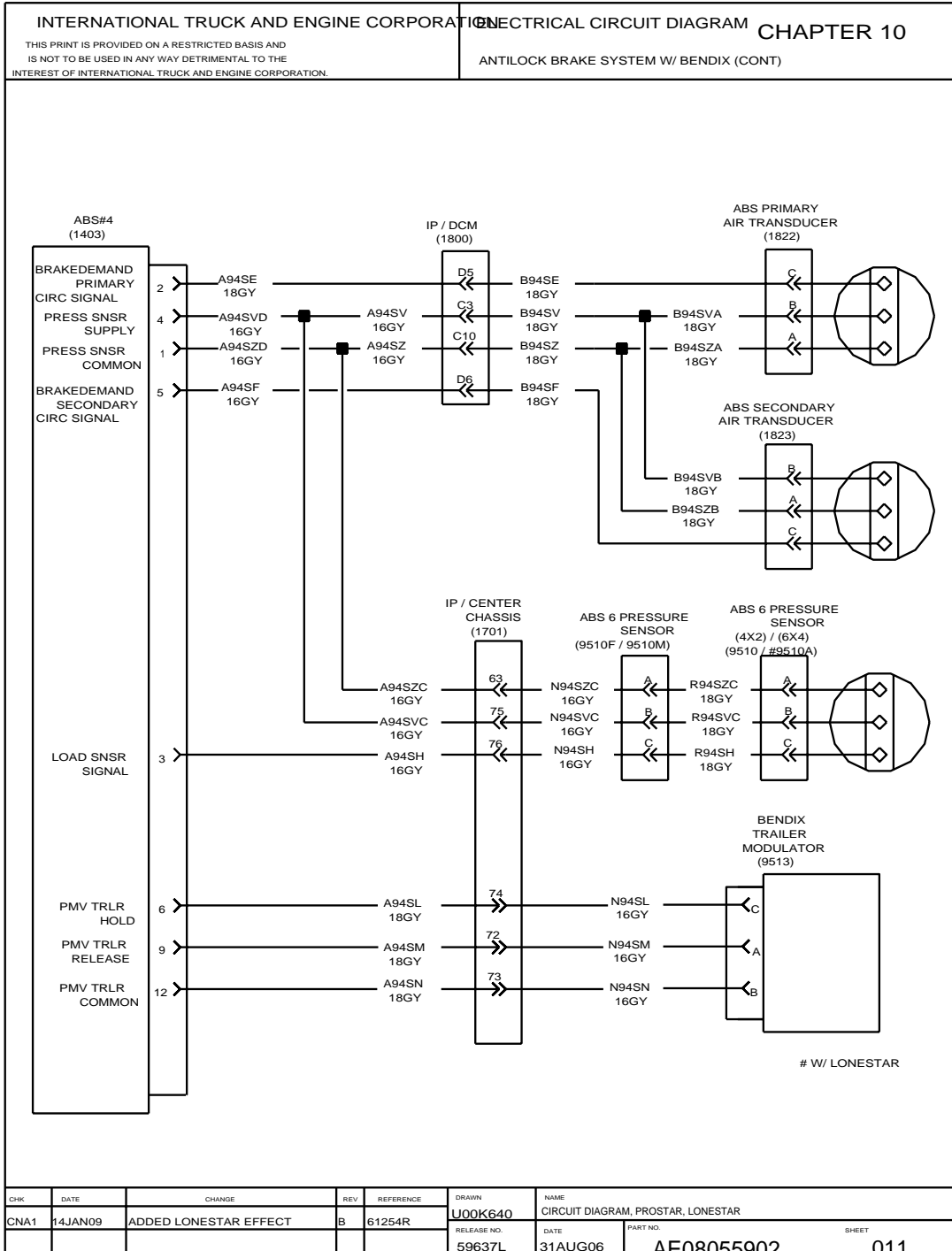


Figure 184 Antilock Brake System W/Bendix

10.13. ANTILOCK BRAKE SYSTEM W/BENDIX, P. 12

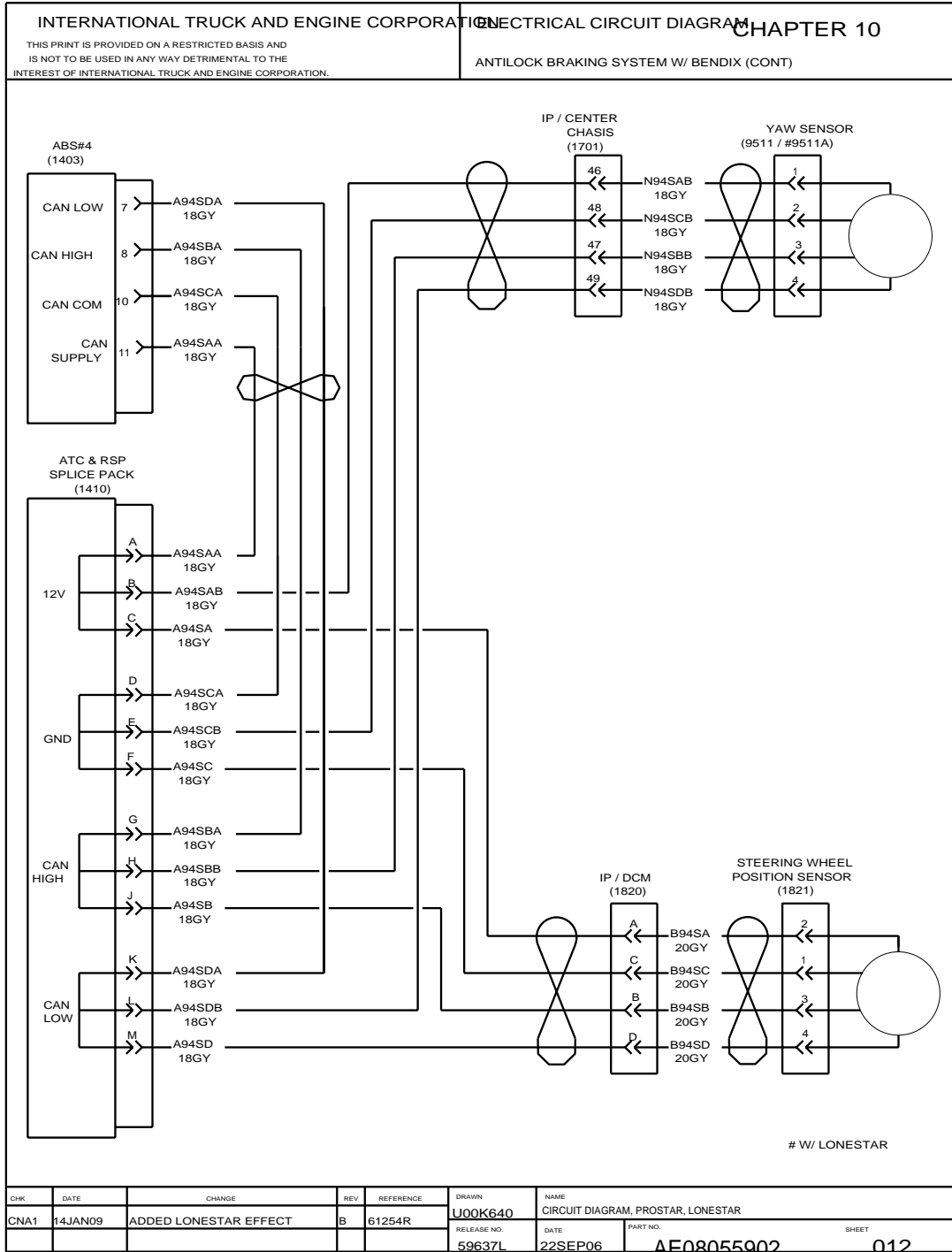


Figure 185 Antilock Brake System W/Bendix

10.14. ANTILOCK BRAKE SYSTEM W/WABCO, P. 13

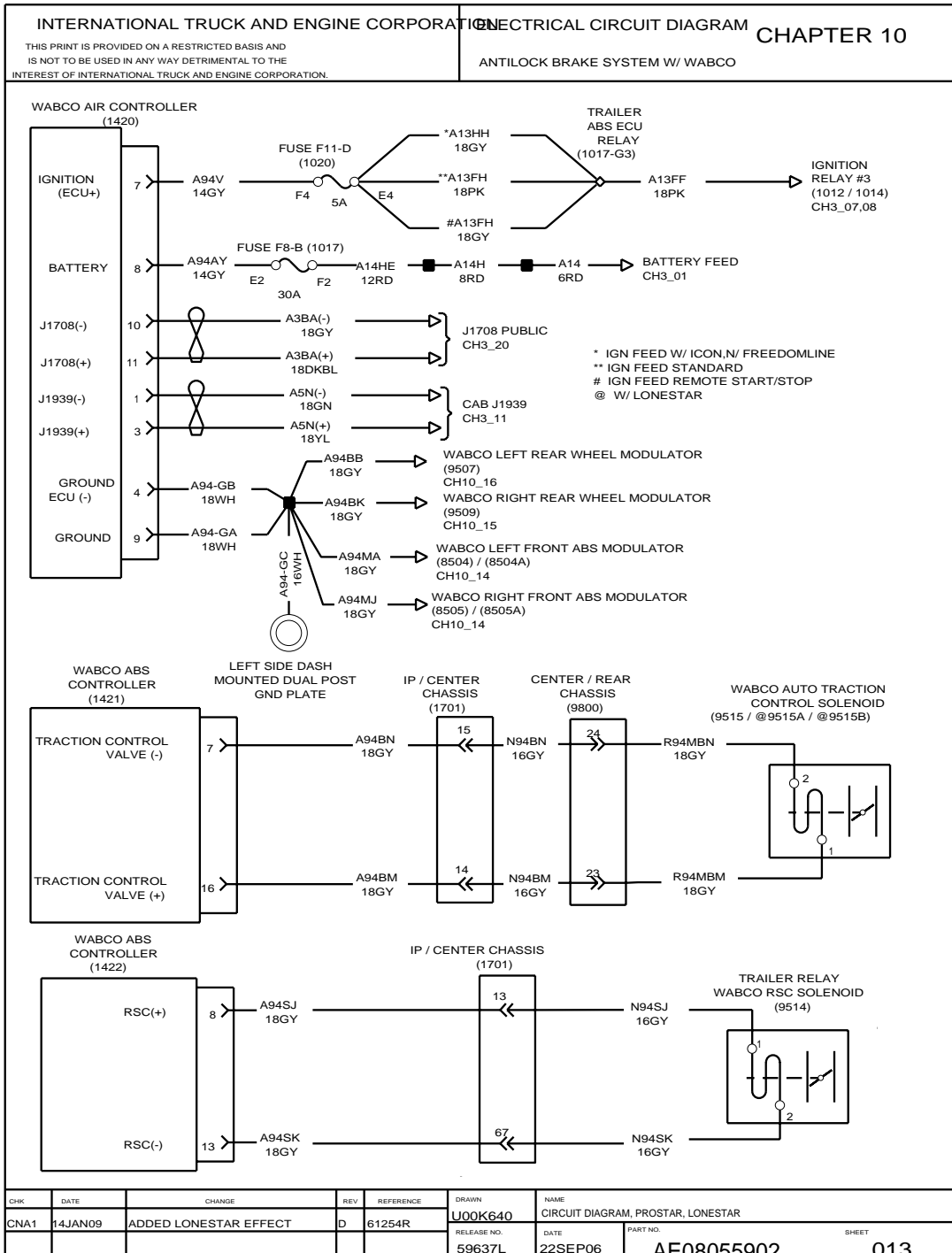


Figure 186 Anti-lock Brake System W/WABCO

10.15. ANTILOCK BRAKE SYSTEM W/WABCO, P. 14

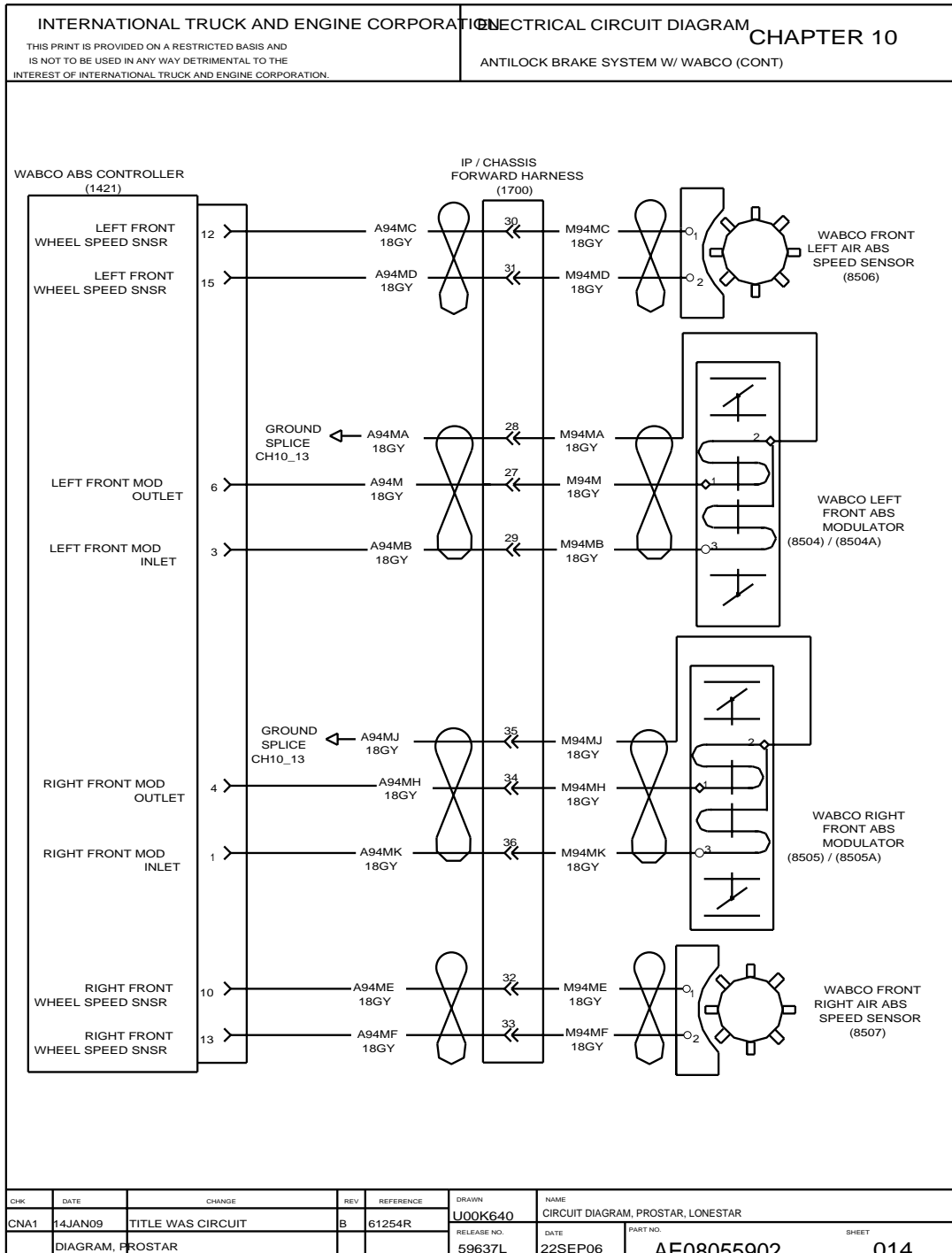


Figure 187 Antilock Brake System W/WABCO

10.16. ANTILOCK BRAKE SYSTEM W/WABCO, P. 15

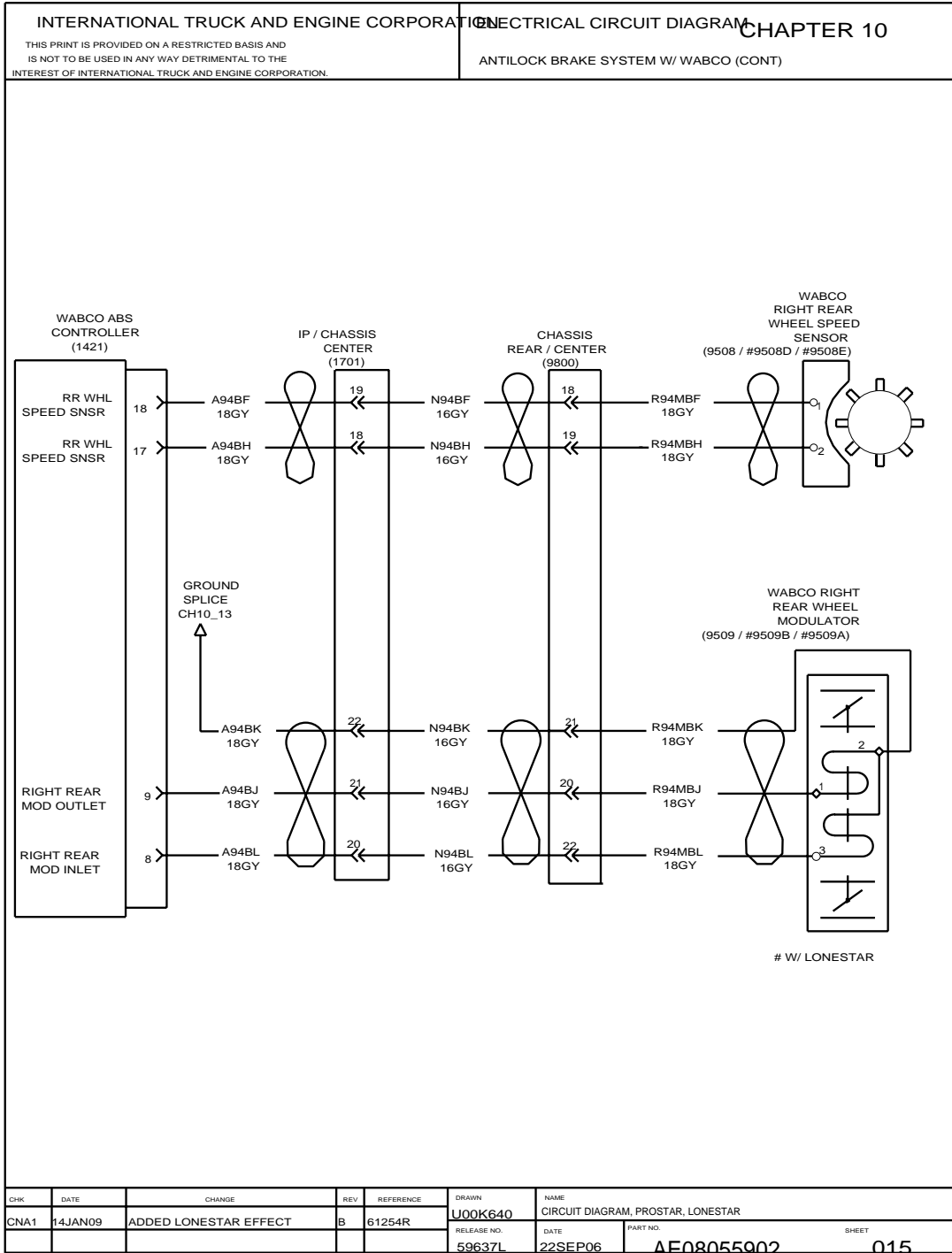


Figure 188 Antilock Brake System W/WABCO

10.17. ANTILOCK BRAKE SYSTEM W/WABCO, P. 16

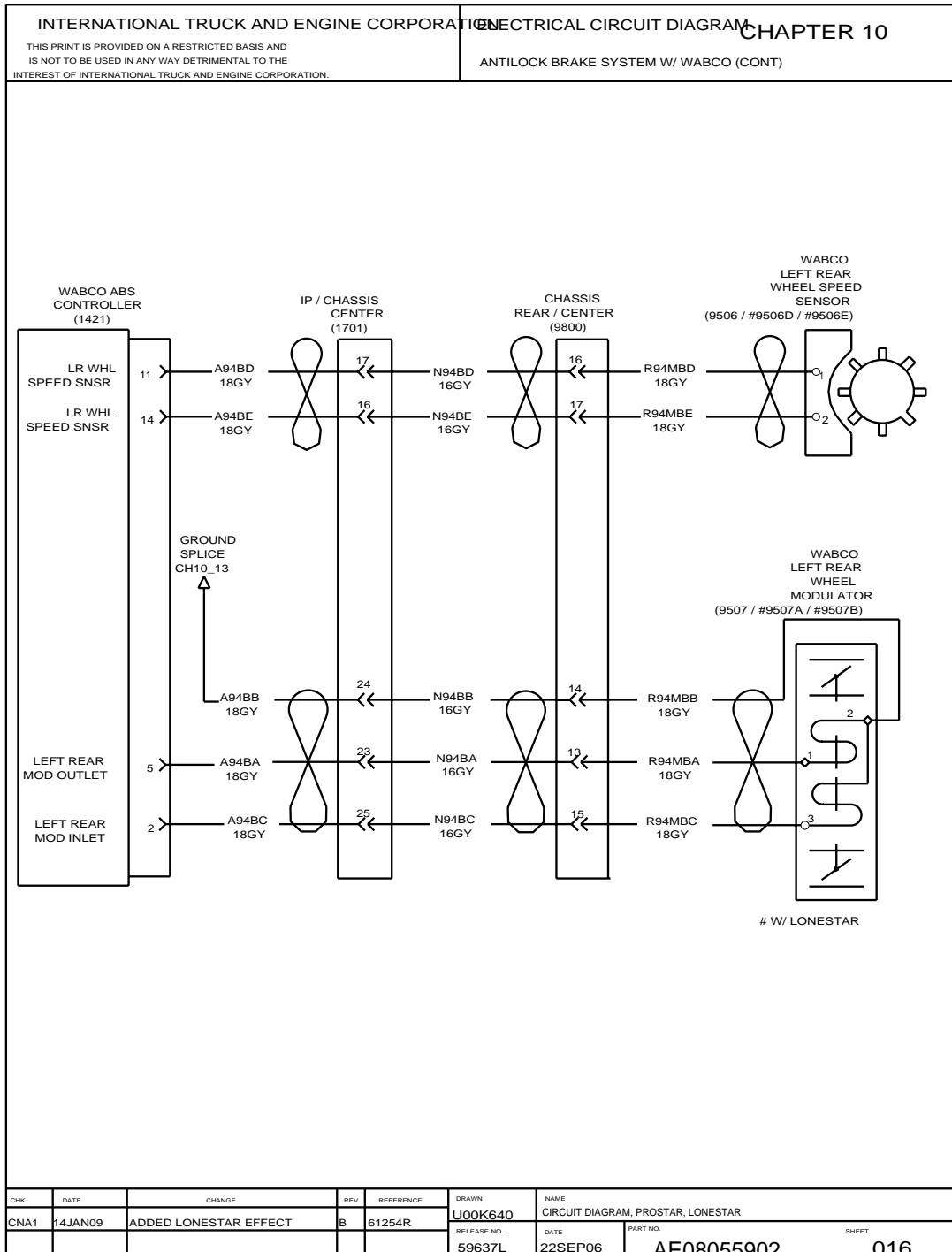


Figure 189 Antilock Brake System W/WABCO

10.18. ANTILOCK BRAKE SYSTEM W/WABCO, P. 17

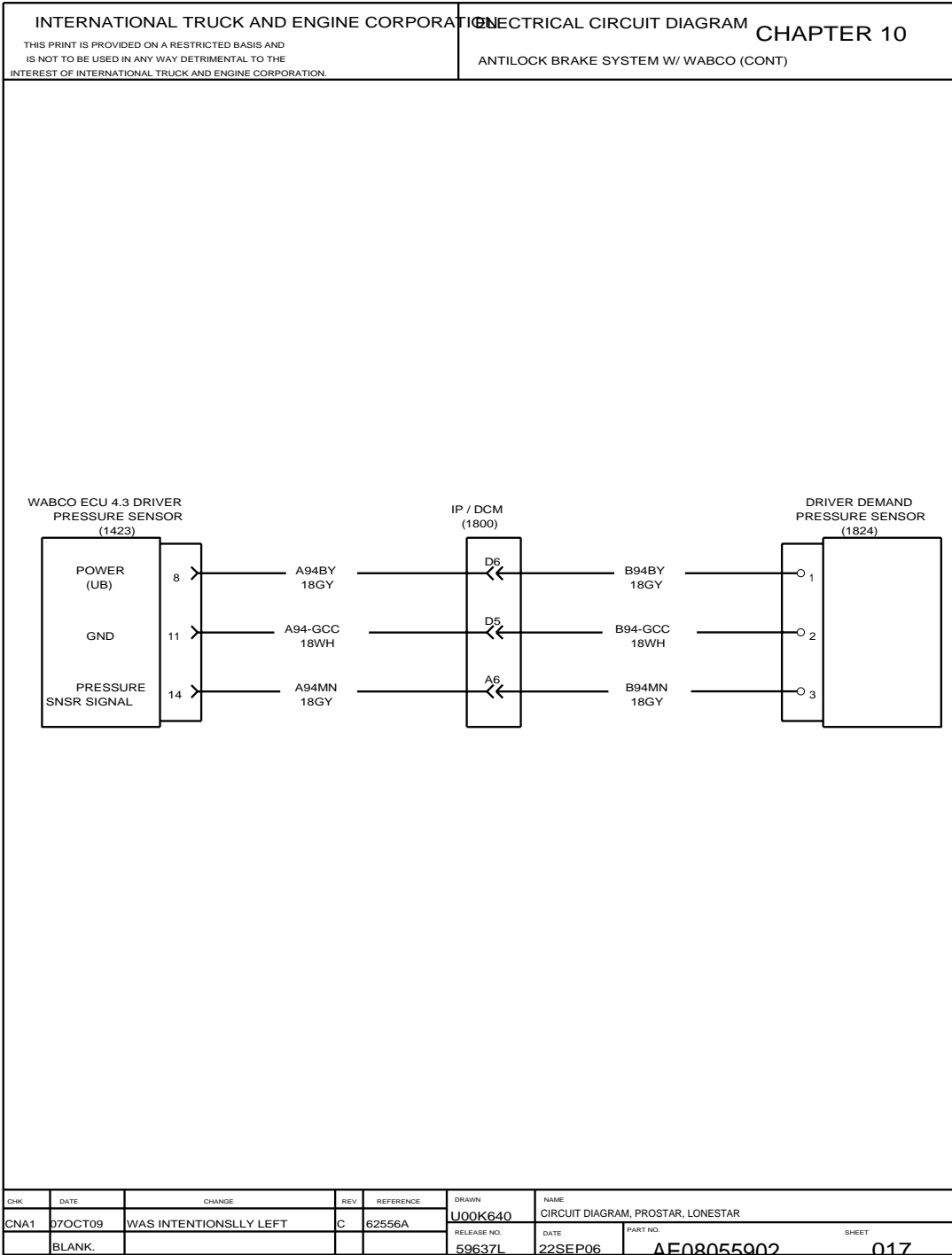


Figure 190 Antilock Brake System W/WABCO

10.19. POWER TAKE OFF, P. 18

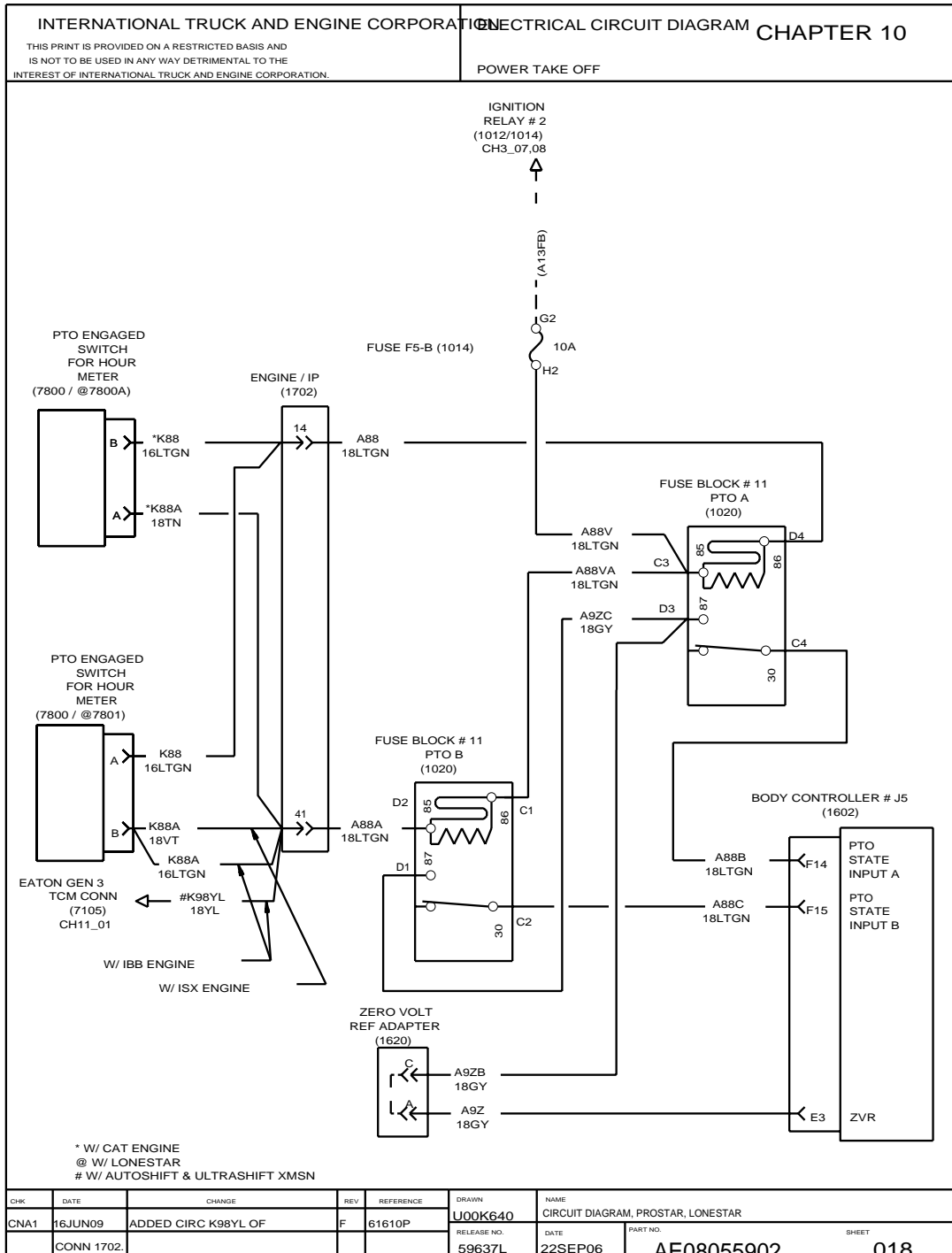


Figure 191 Power Take Off

10.20. FUEL LEVEL, P. 19

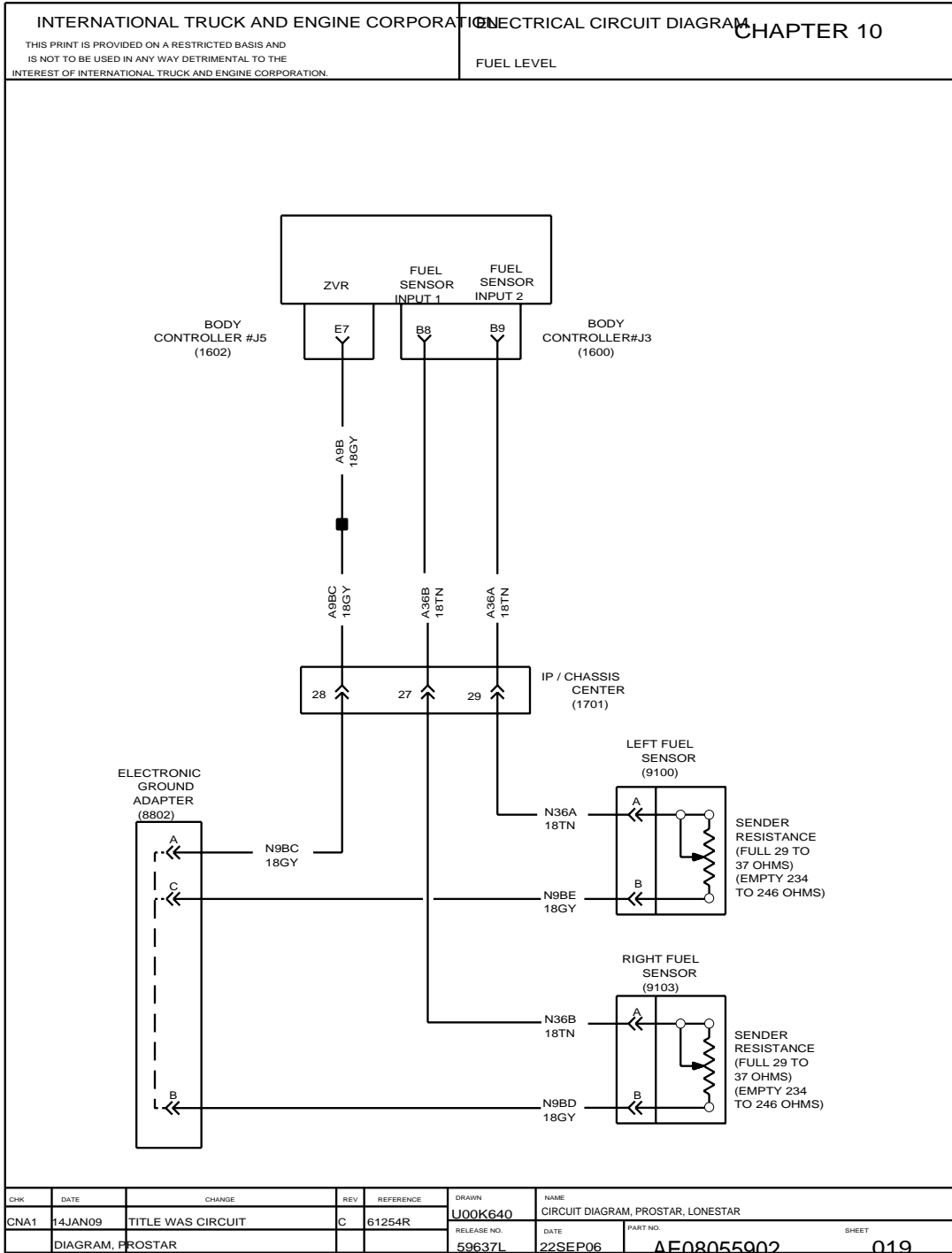


Figure 192 Fuel Level

10.21. VEHICLE SENSOR MODULE, P. 20

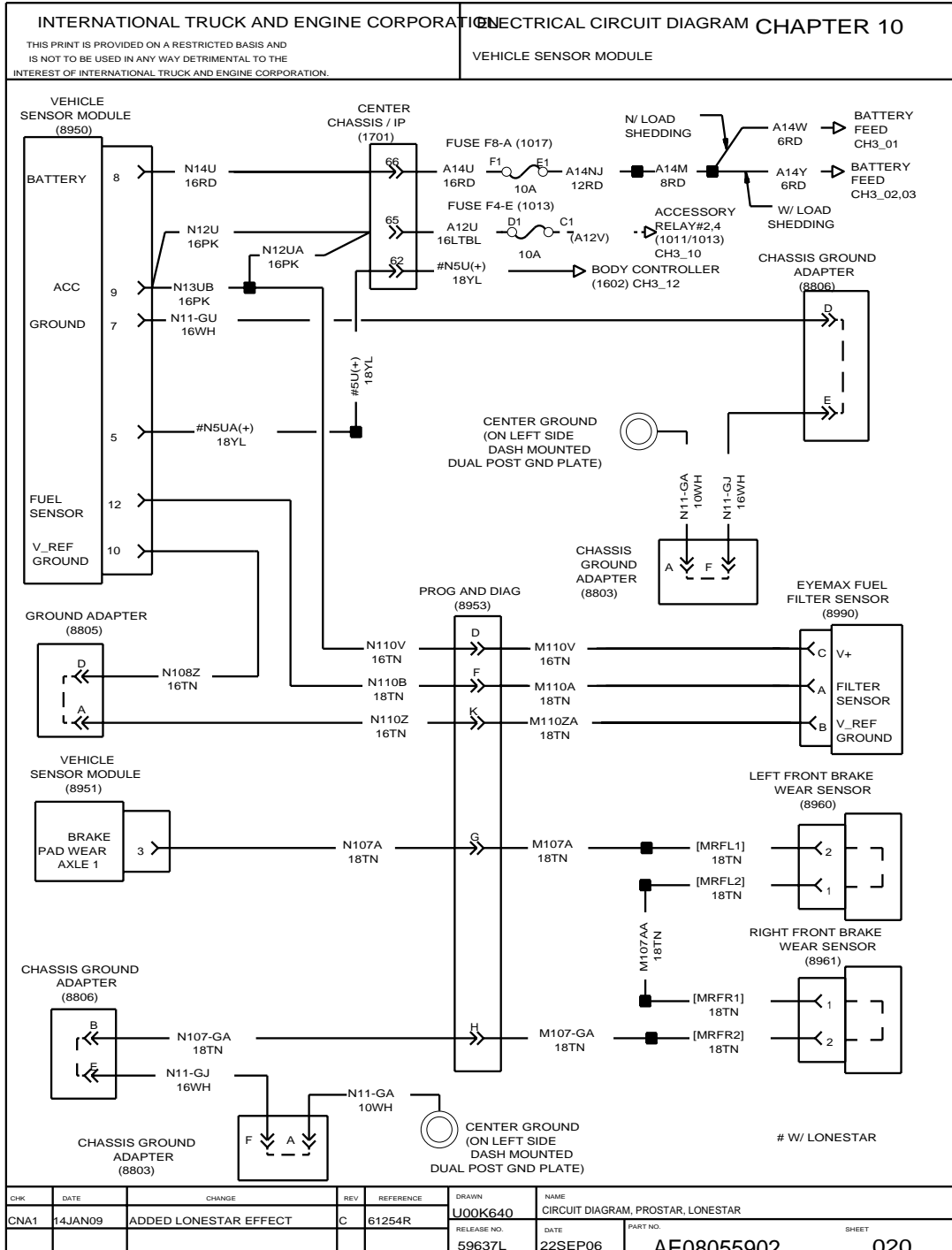


Figure 193 Vehicle Sensor Module

10.22. VEHICLE SENSOR MODULE, P. 21

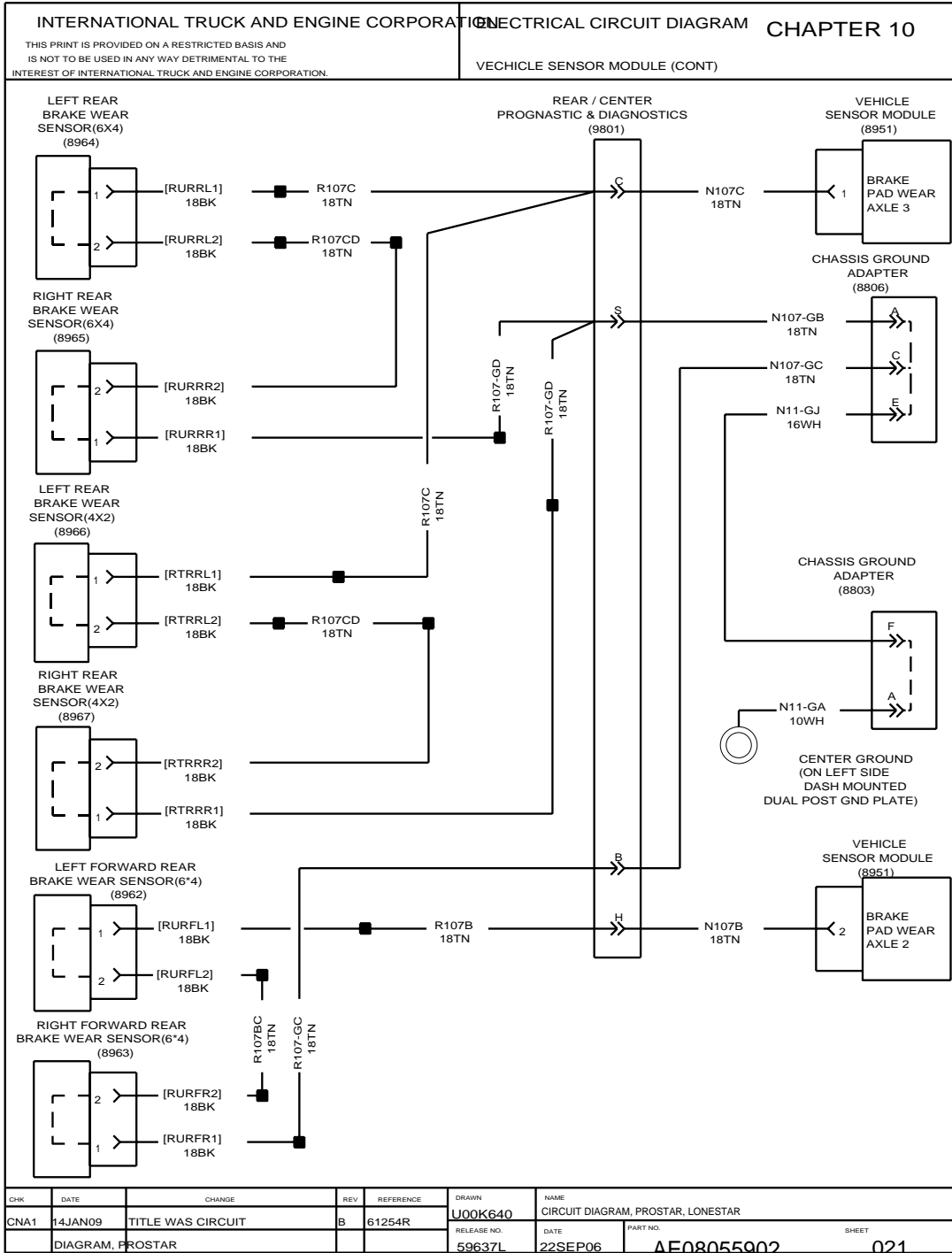


Figure 194 Vehicle Sensor Module

10.23. BRAKE SENSOR — WEAR/STROKE, P. 22

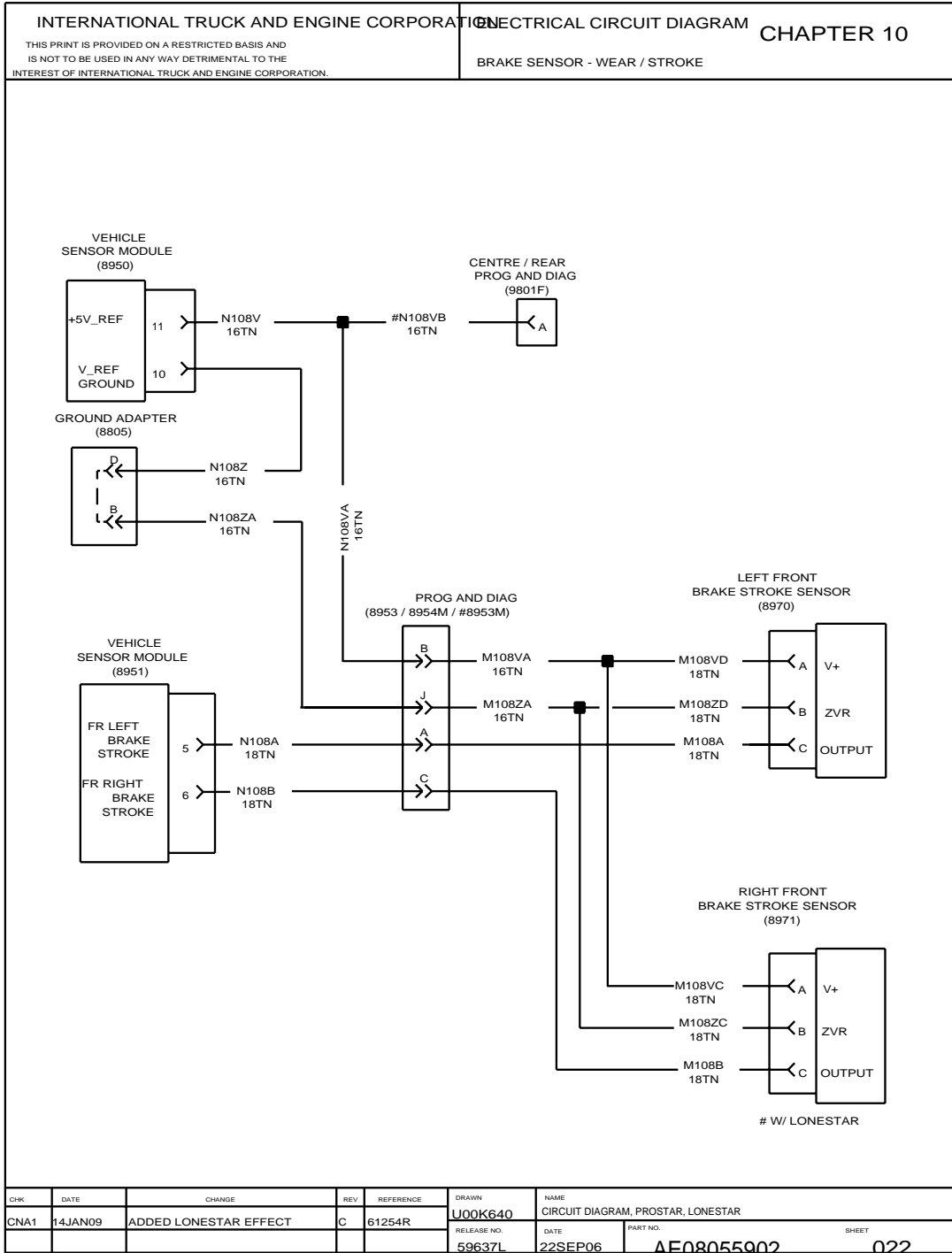


Figure 195 Brake Sensor — Wear/Stroke

10.24. BRAKE SENSOR — WEAR/STROKE, P. 23

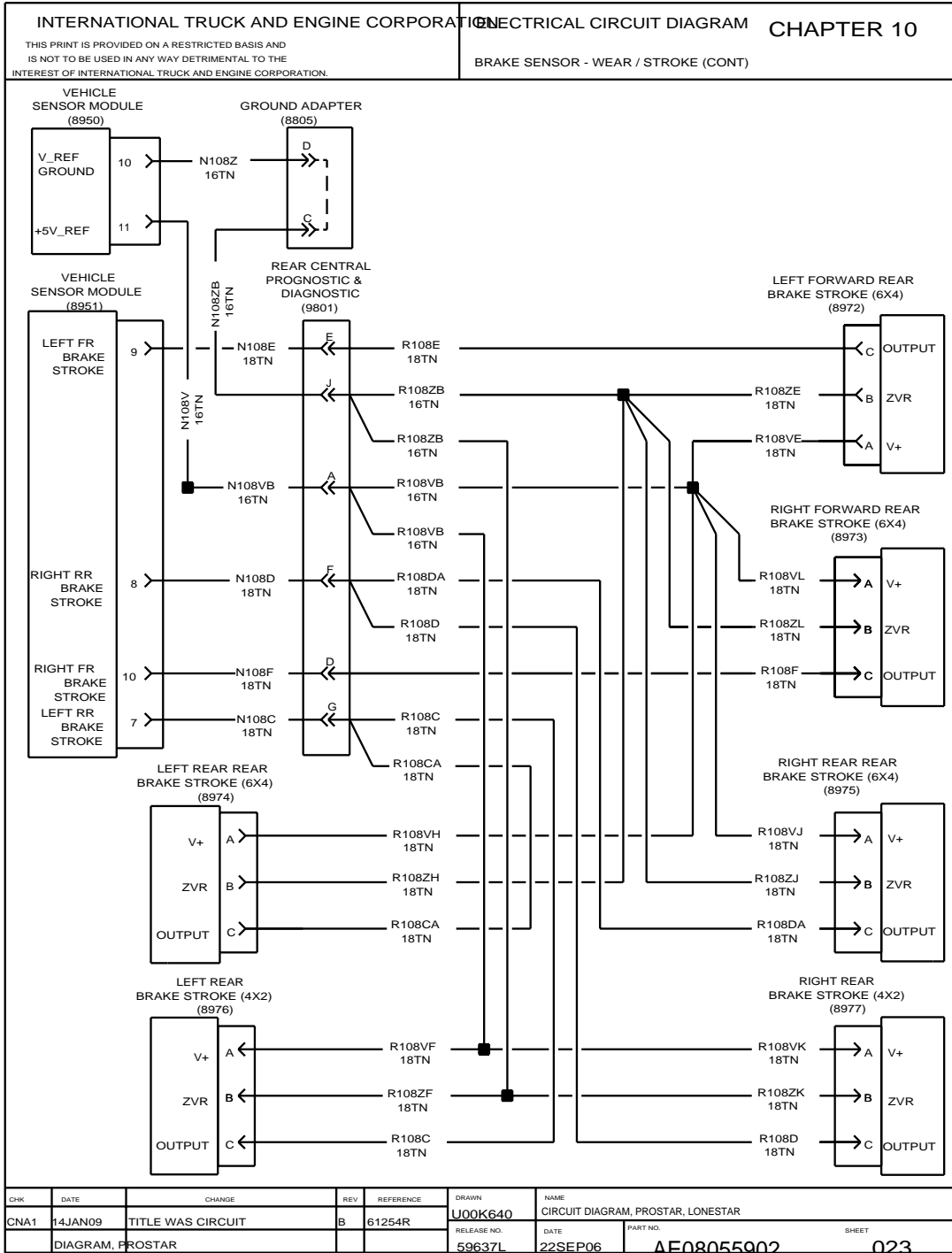


Figure 196 Brake Sensor — Wear/Stroke

## 11. TRANSMISSION CONTROL MODULE (CHAPTER 11)

### 11.1. EATON AUTOSHIFT AND ULTRASHIFT TRANSMISSION, P. 1

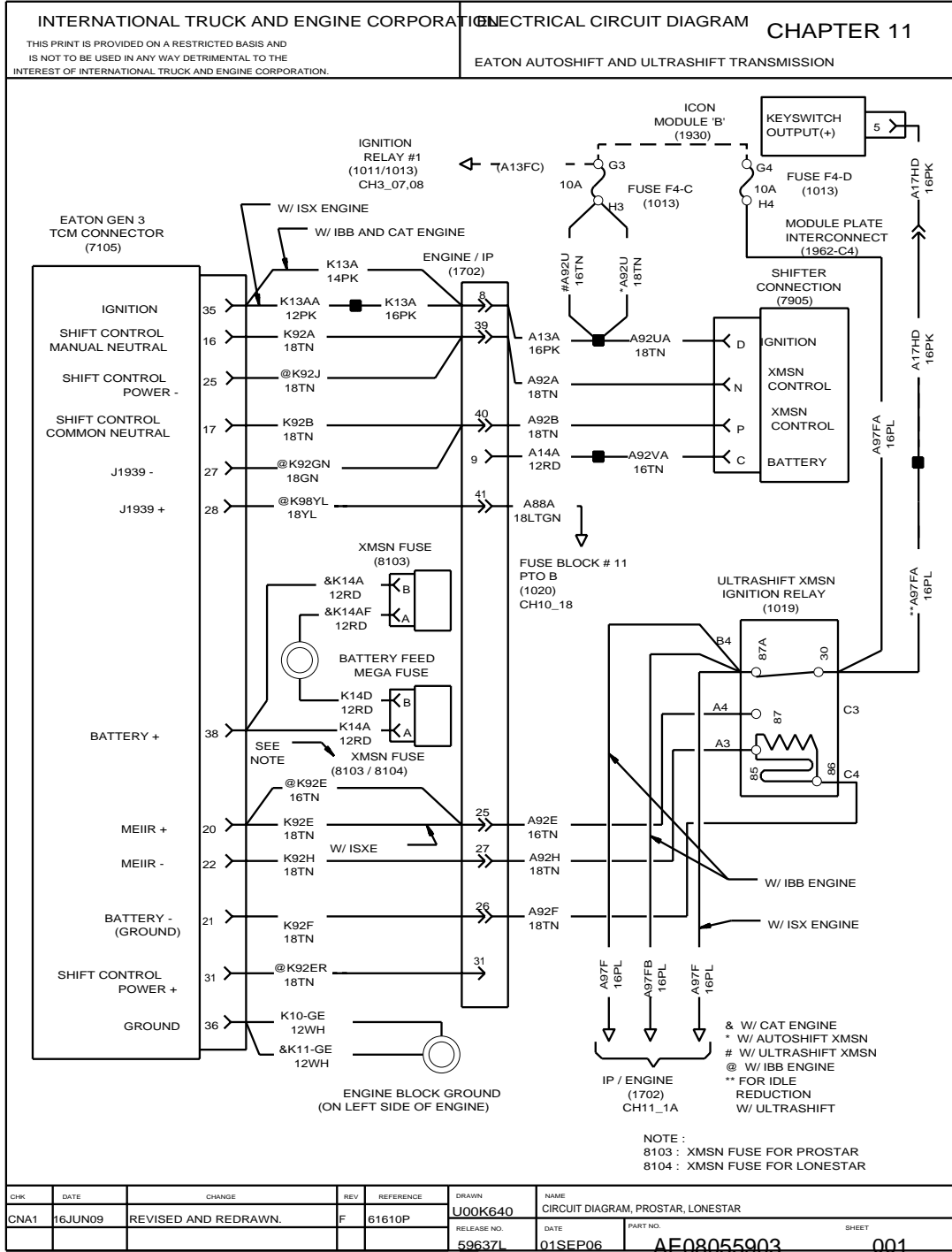


Figure 197 Eaton Autoshift and Ultrashift Transmission

11.2. EATON AUTOSHIFT AND ULTRASHIFT TRANSMISSION, P. 1A

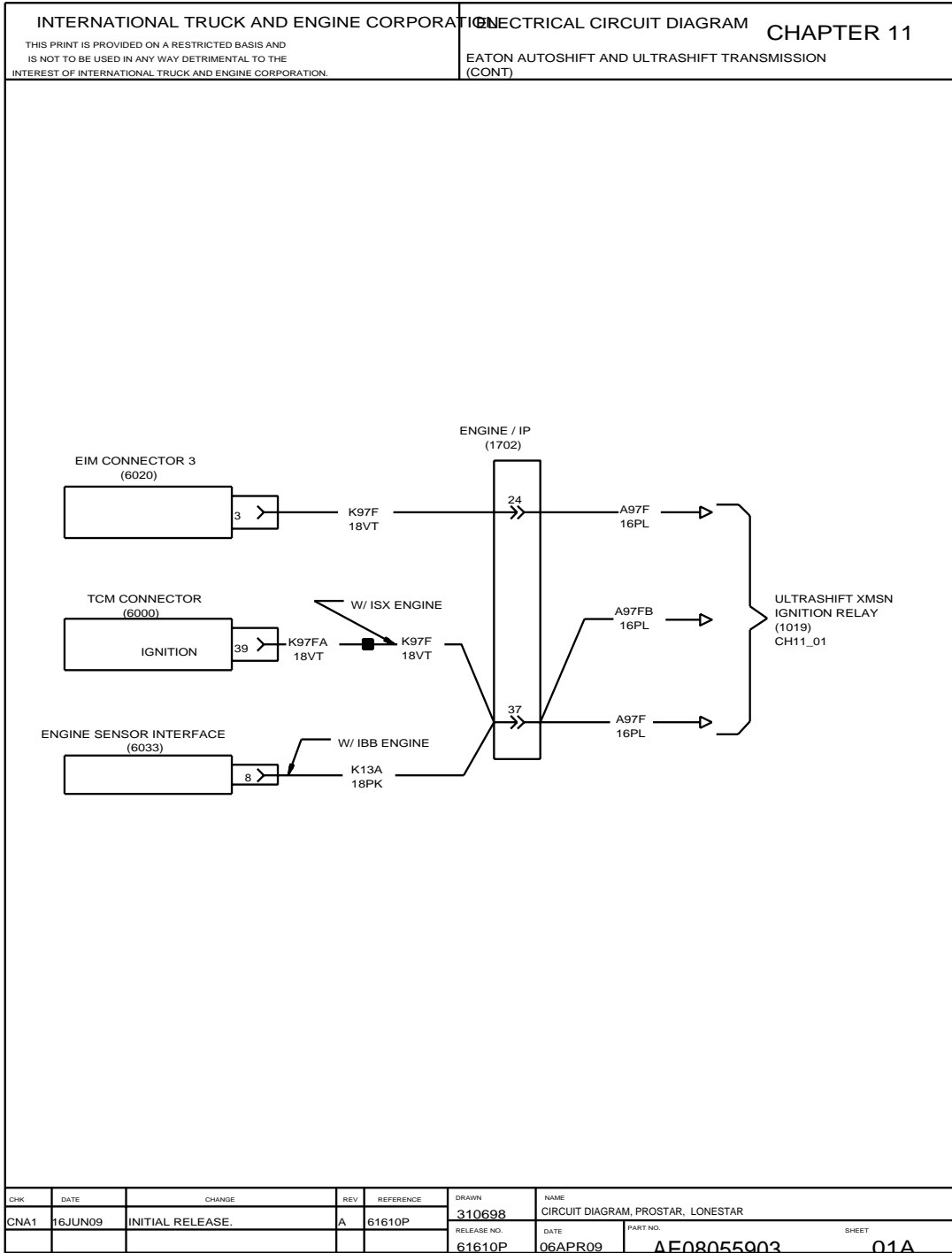


Figure 198 Eaton Autoshift and Ultrashift Transmission

11.3. COLUMN SHIFTER AND MERITOR G TRANSMISSION, P. 2

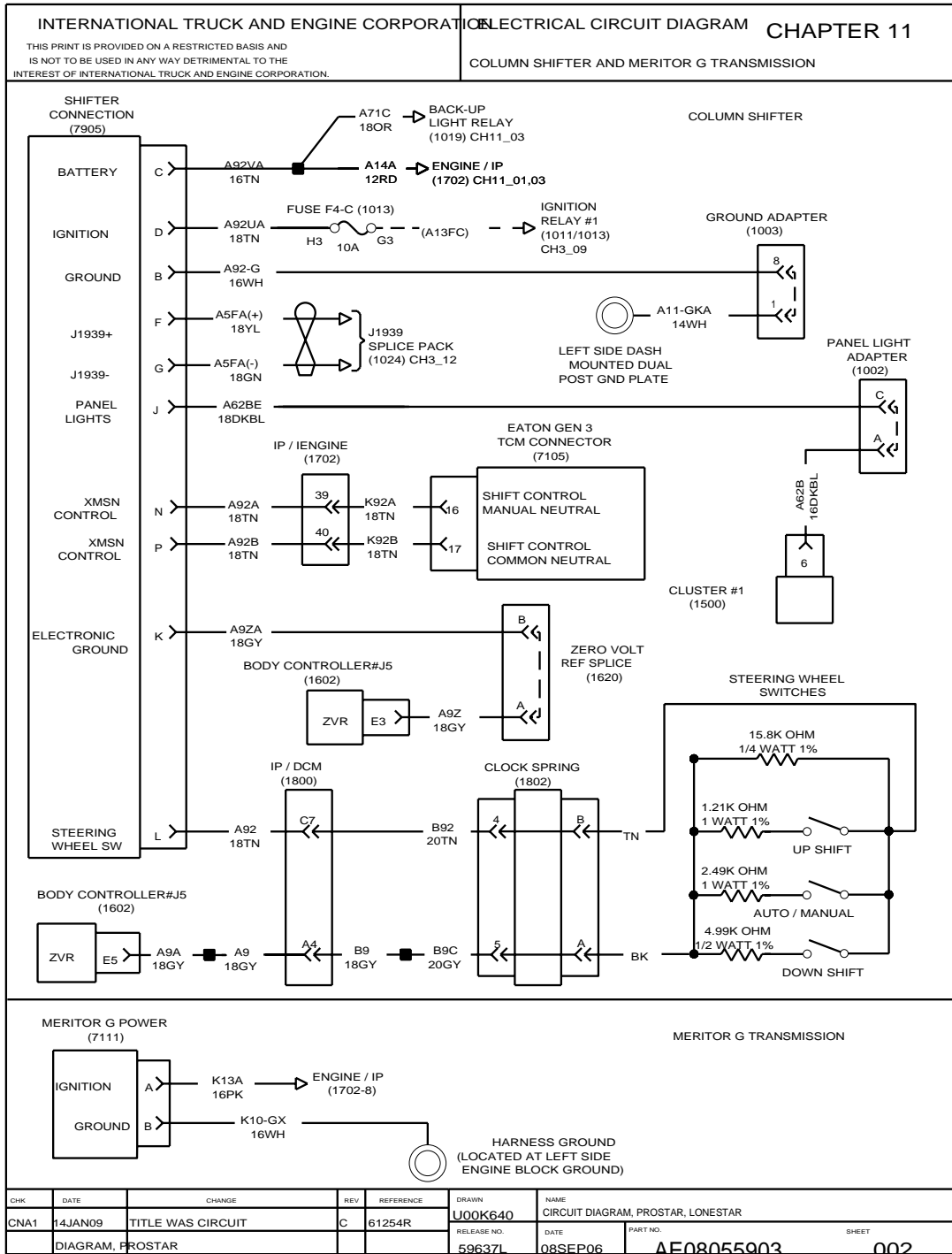


Figure 199 Column Shifter and Meritor G Transmission

11.4. FREEDOMLINE TRANSMISSION, P. 3

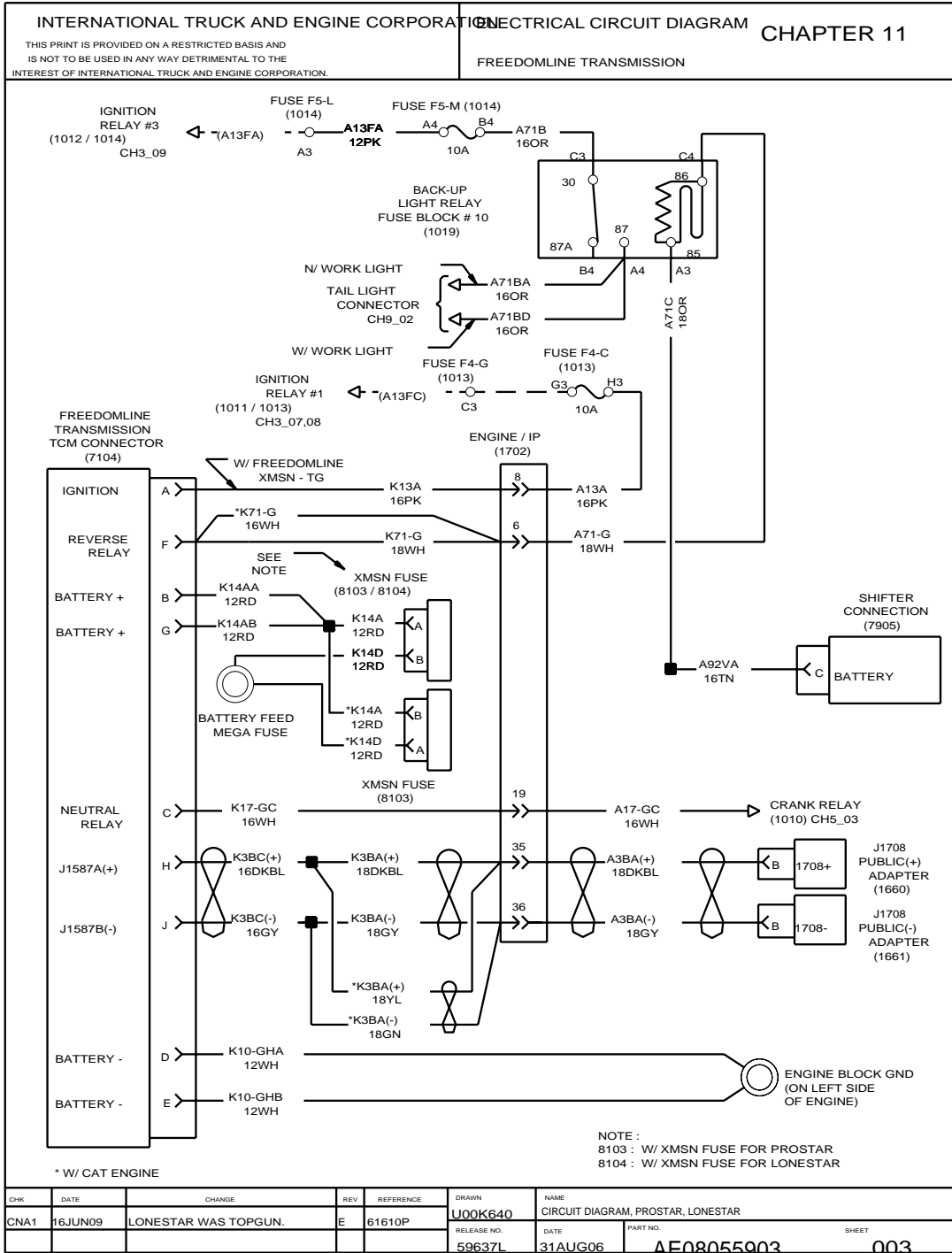


Figure 200 Freedomline Transmission

## 12. HVAC (CHAPTER 12)

### 12.1. AIR CONDITIONING, P. 1

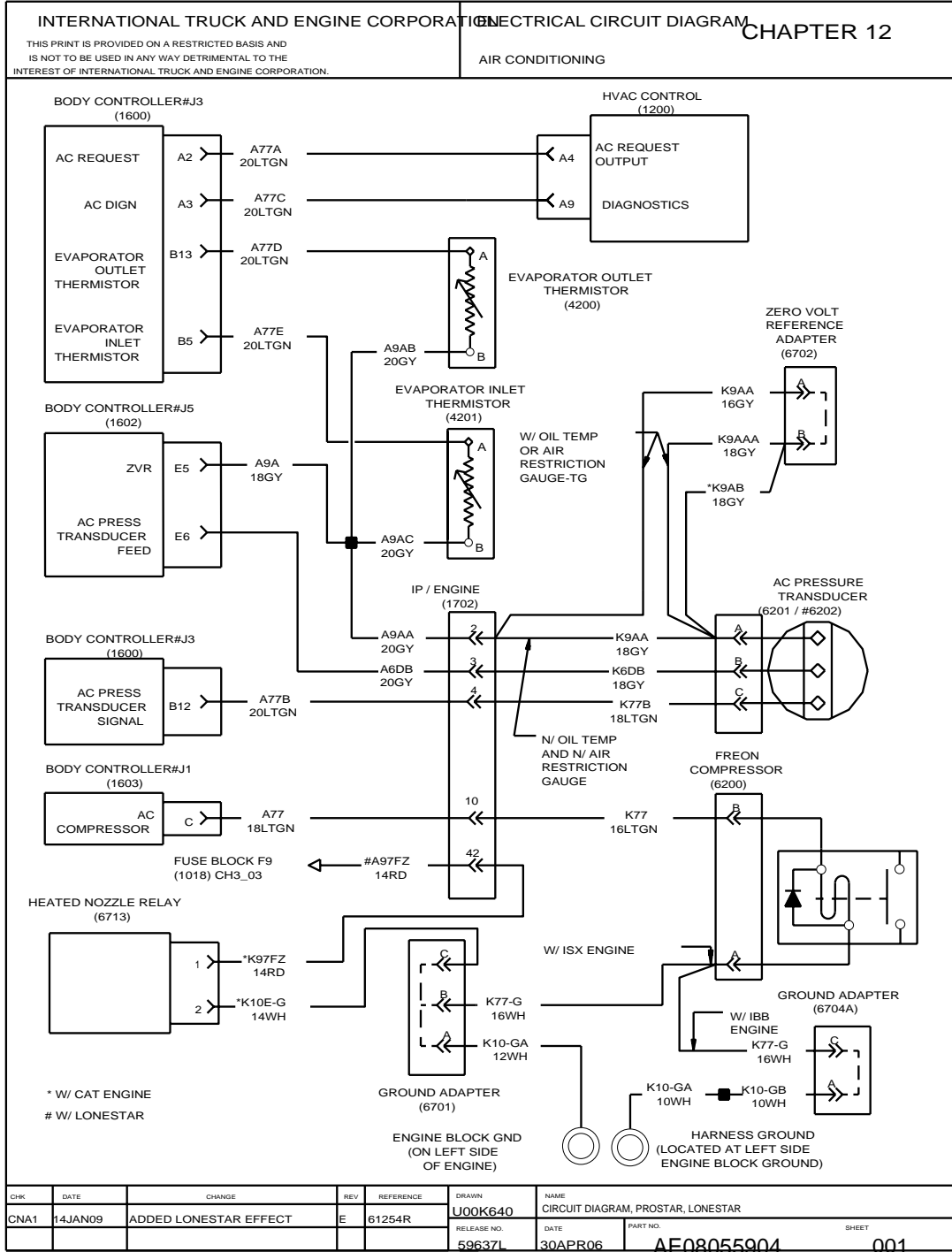


Figure 201 Air Conditioning

12.2. HVAC SYSTEM — CAB, P. 2

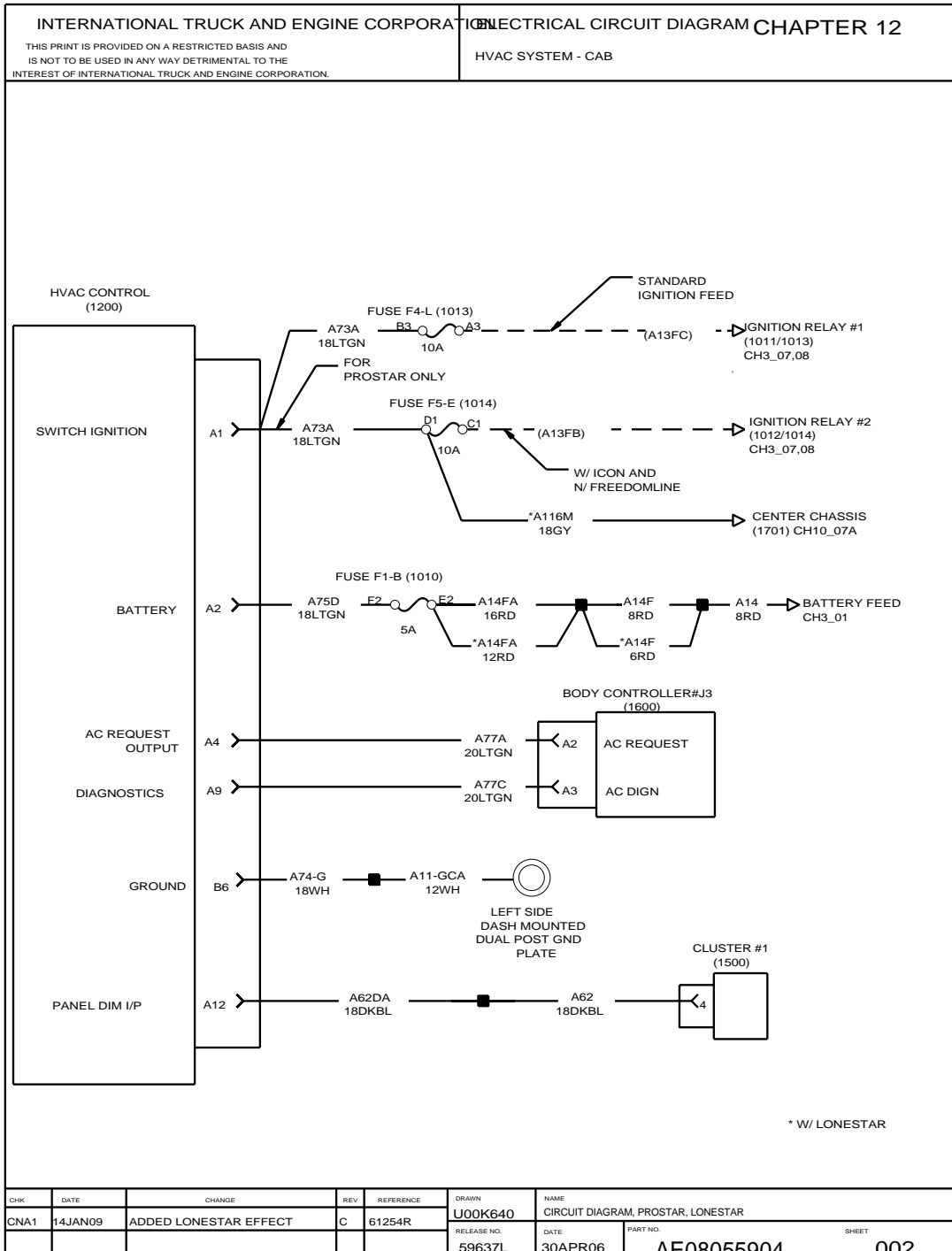


Figure 202 HVAC System — Cab

12.3. HVAC SYSTEM — CAB, P. 3

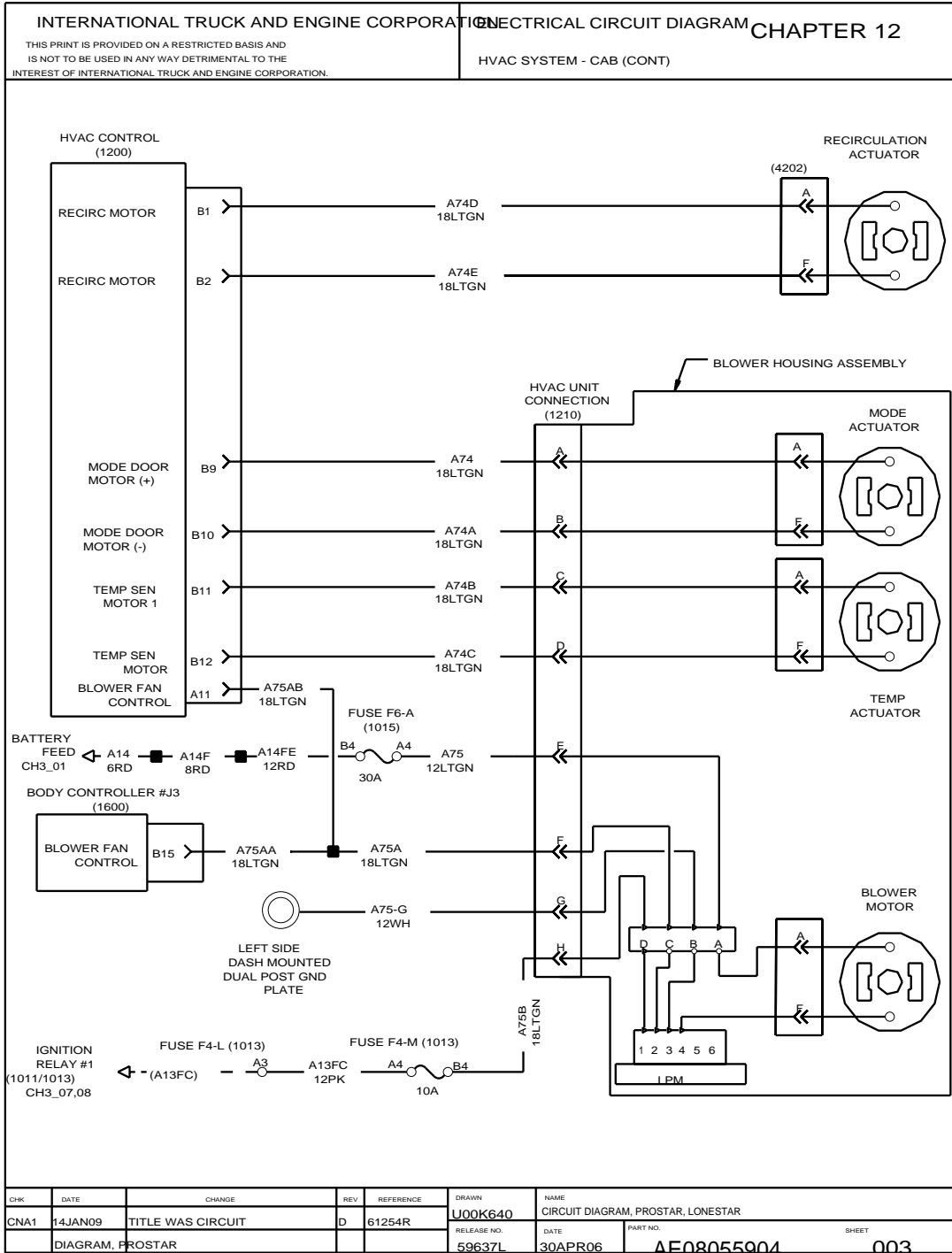


Figure 203 HVAC System — Cab

12.4. HVAC SYSTEM — SLEEPER, P. 4

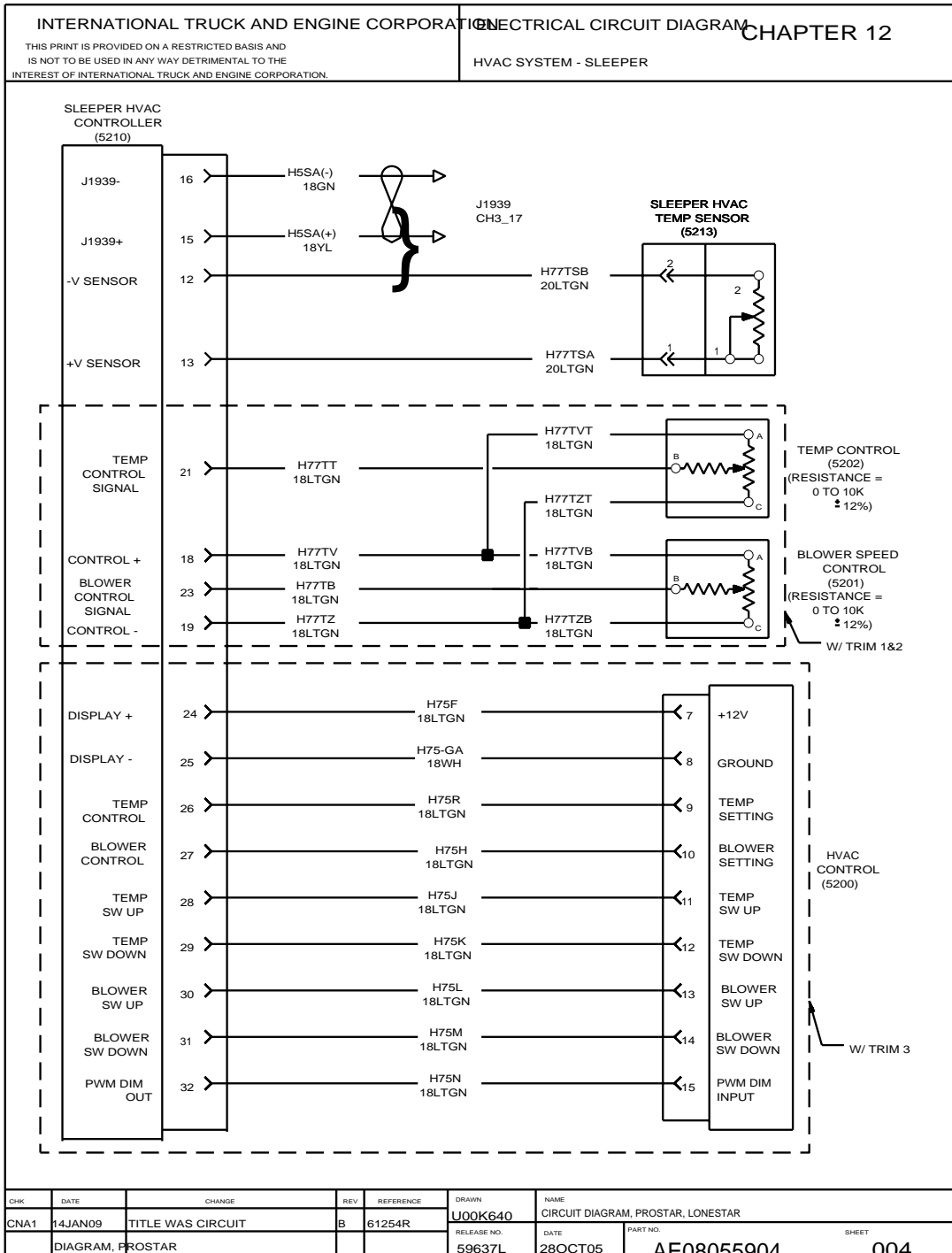


Figure 204 HVAC System — Sleeper

12.5. HVAC SYSTEM — SLEEPER, P. 4A

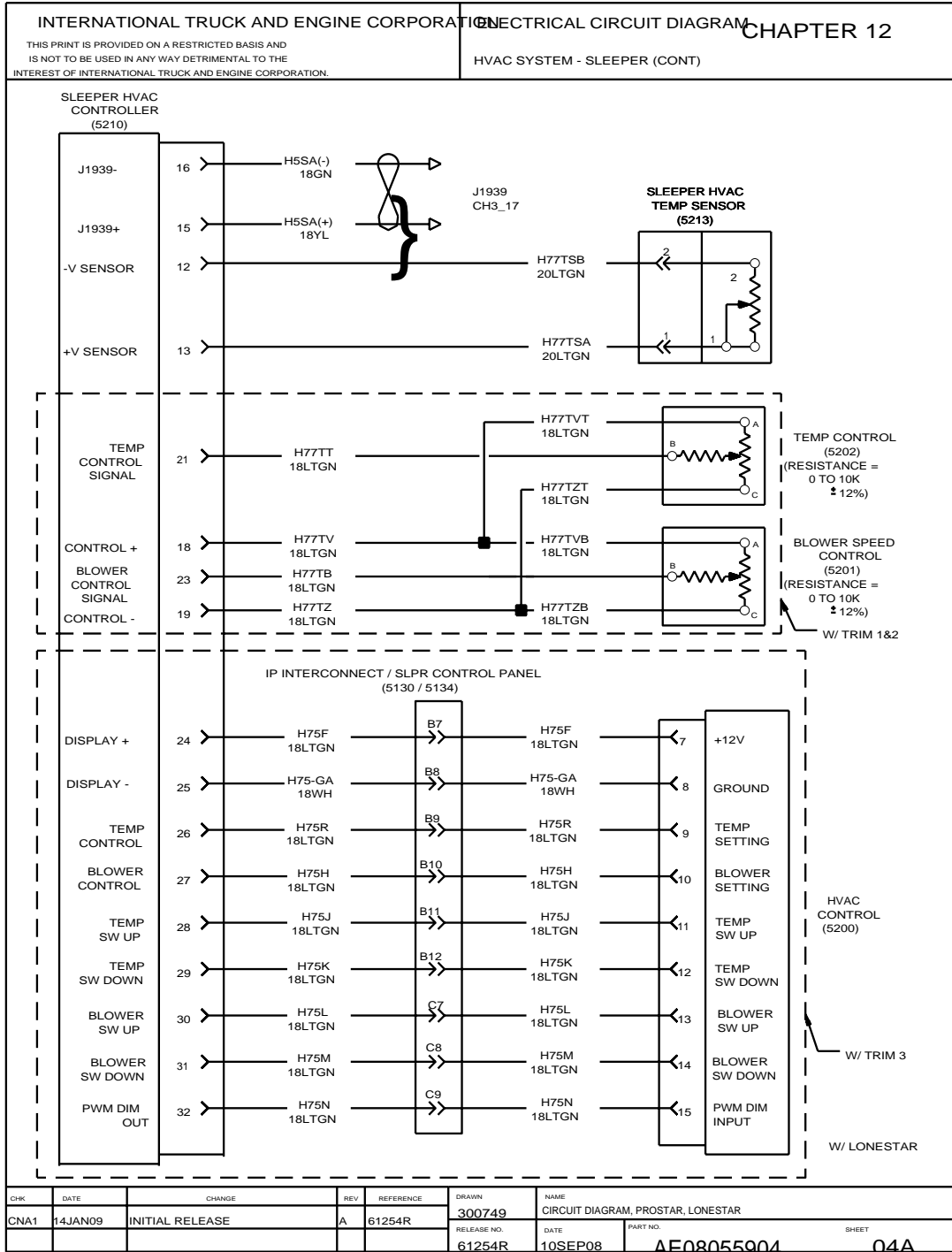


Figure 205 HVAC System — Sleeper

12.6. HVAC SYSTEM — SLEEPER, P. 5

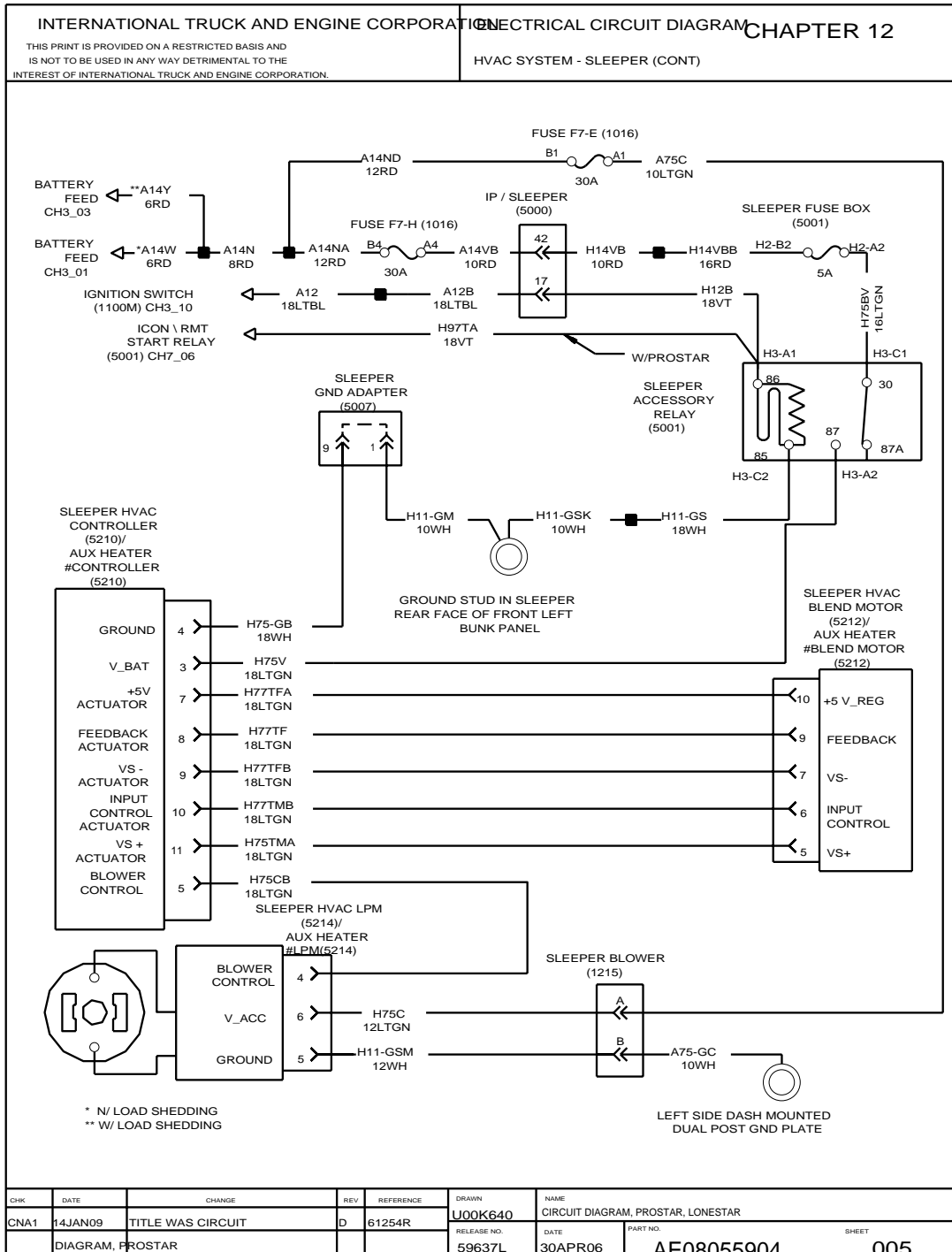


Figure 206 HVAC System — Sleeper

12.7. NO IDLE HEAT AND HVAC — SWITCHES, P. 6

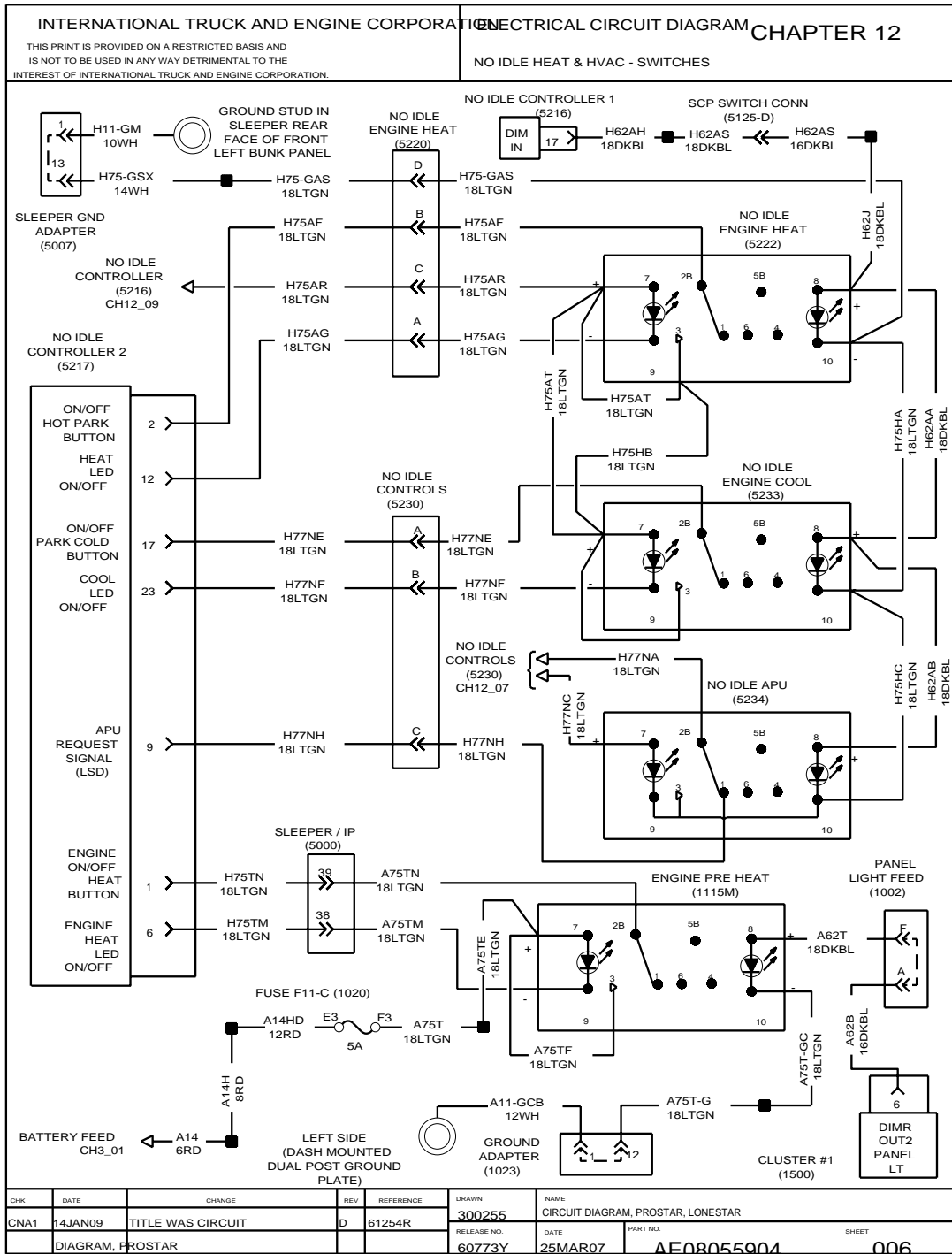


Figure 207 No Idle Heat and HVAC — Switches

12.8. NO IDLE HEAT AND HVAC — APU, P. 7

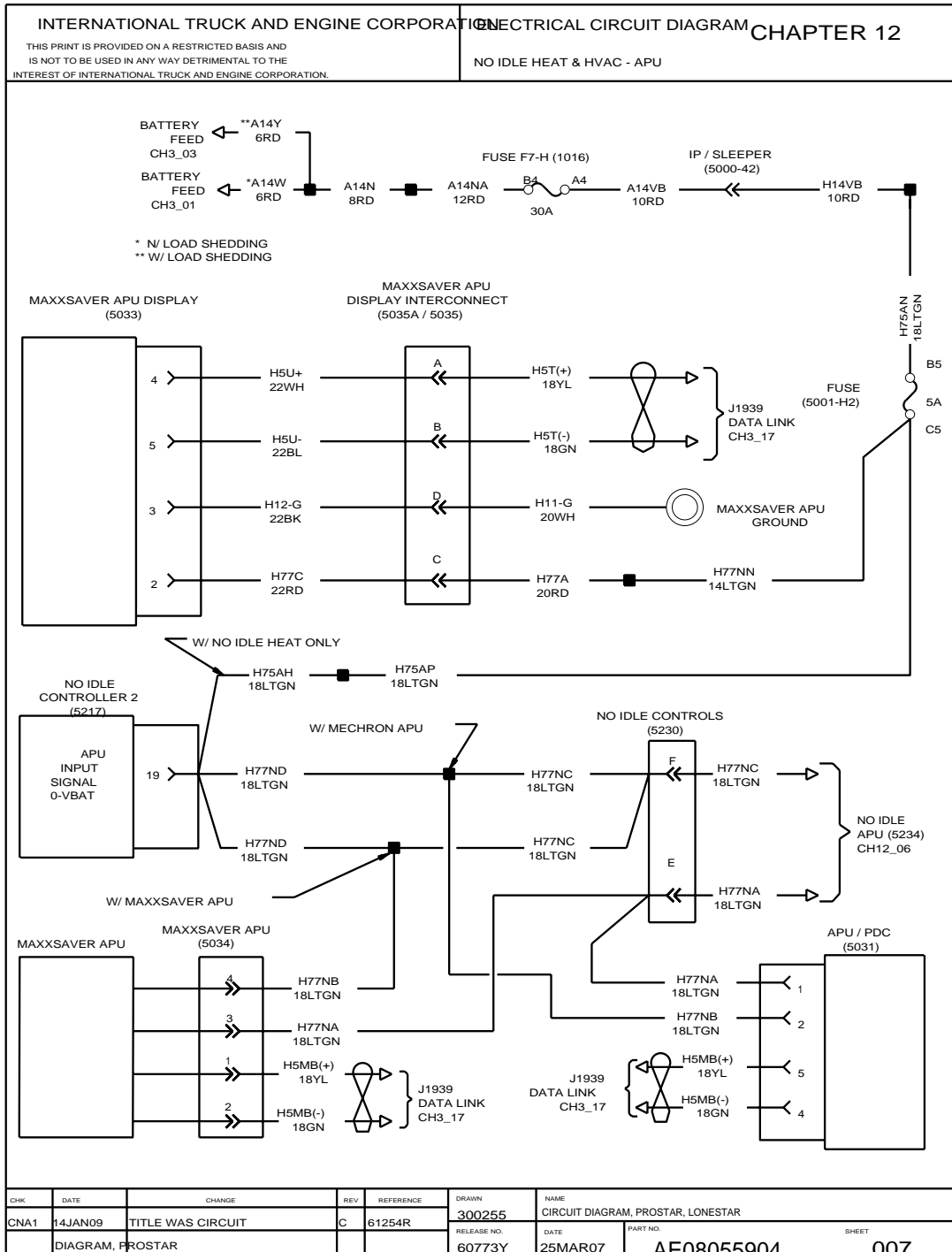


Figure 208 No Idle Heat and HVAC — APU

12.9. NO IDLE HEAT AND HVAC — SENSORS AND HVAC CONTROL, P. 8

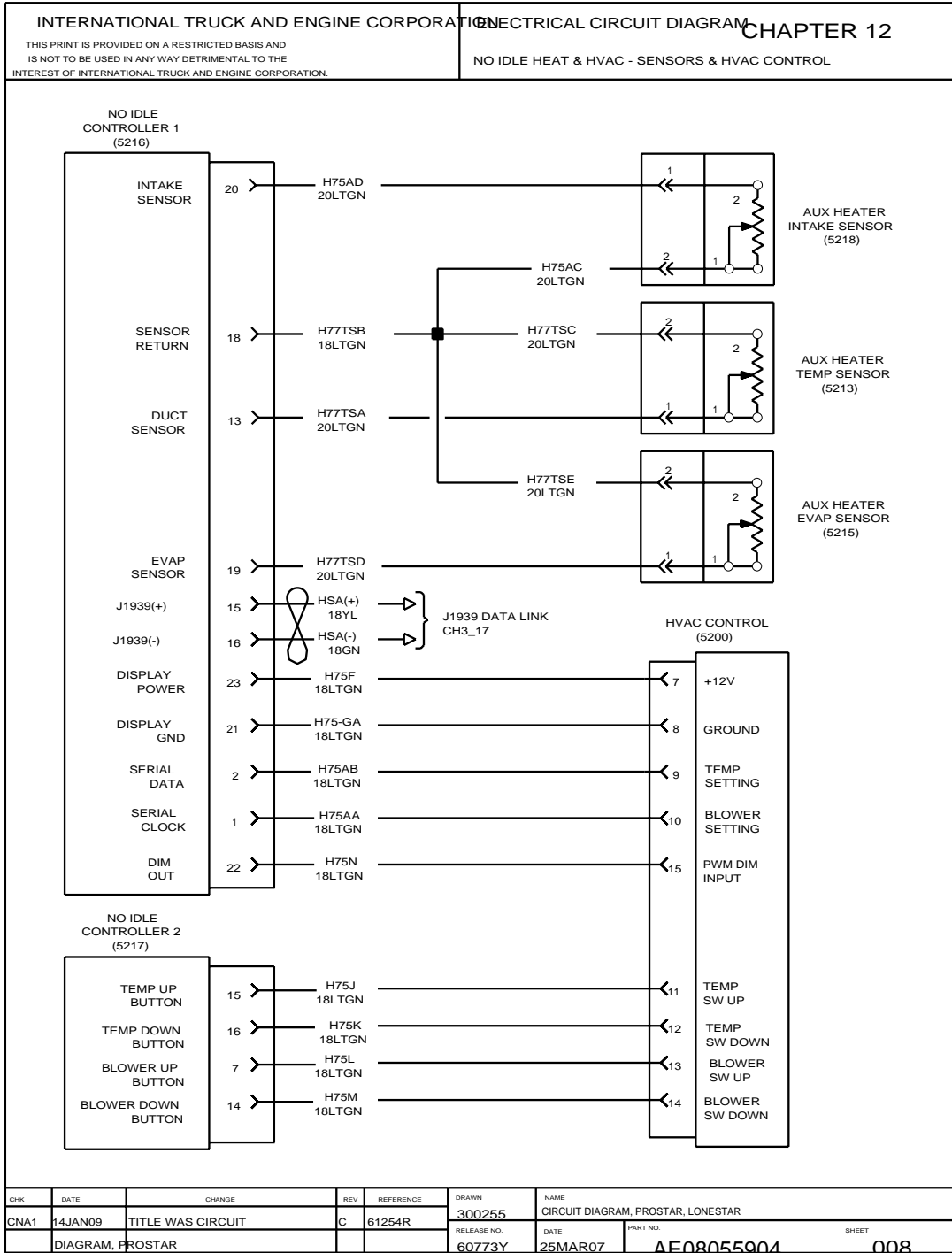


Figure 209 No Idle Heat and HVAC — Sensors and HVAC Control

12.10. NO IDLE HEAT AND HVAC — POWER SUPPLY, P. 9

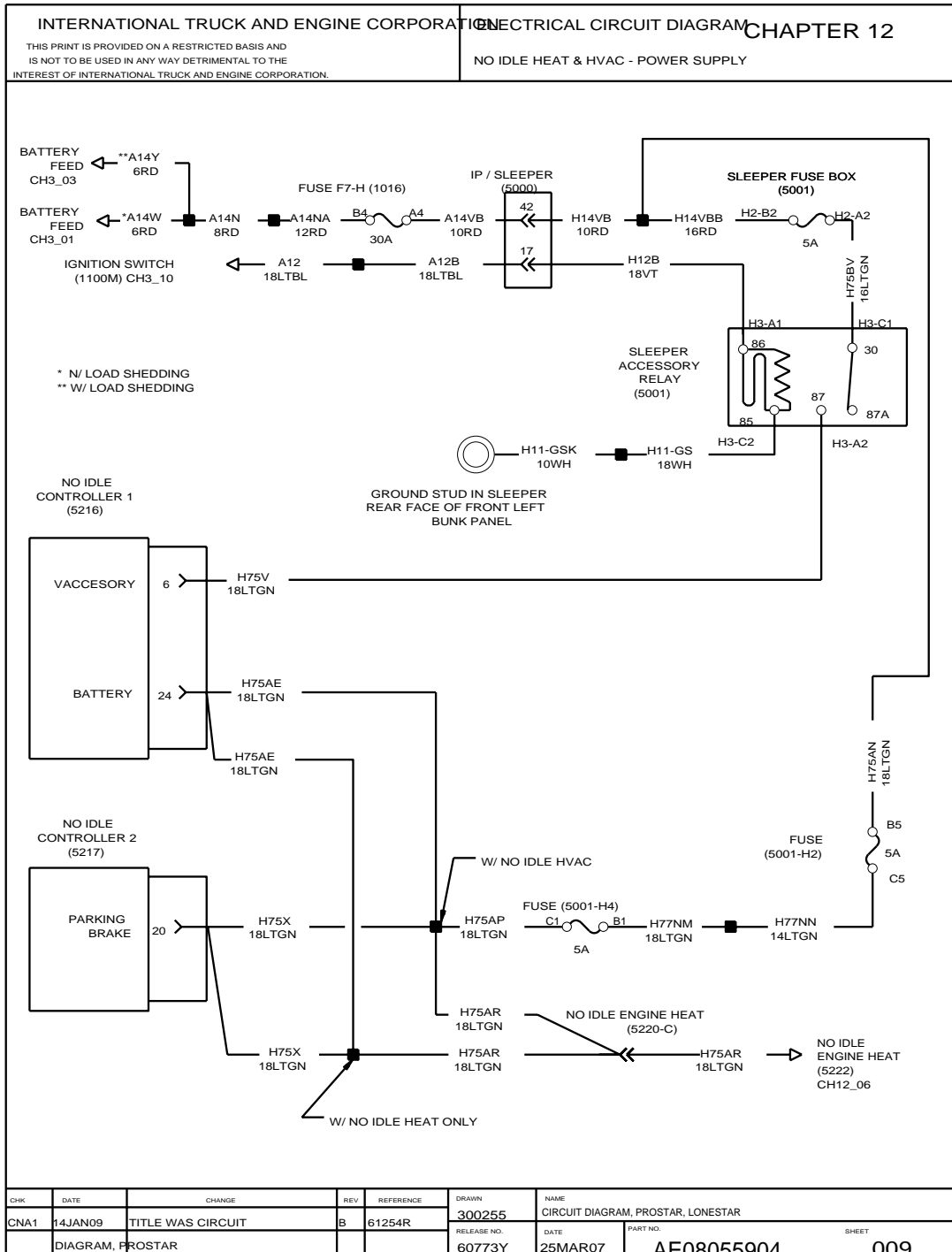


Figure 210 No Idle Heat and HVAC — Power Supply

12.11. NO IDLE HEAT AND HVAC — HEAT VALVE, LPM AND BLEND MOTOR, P. 10

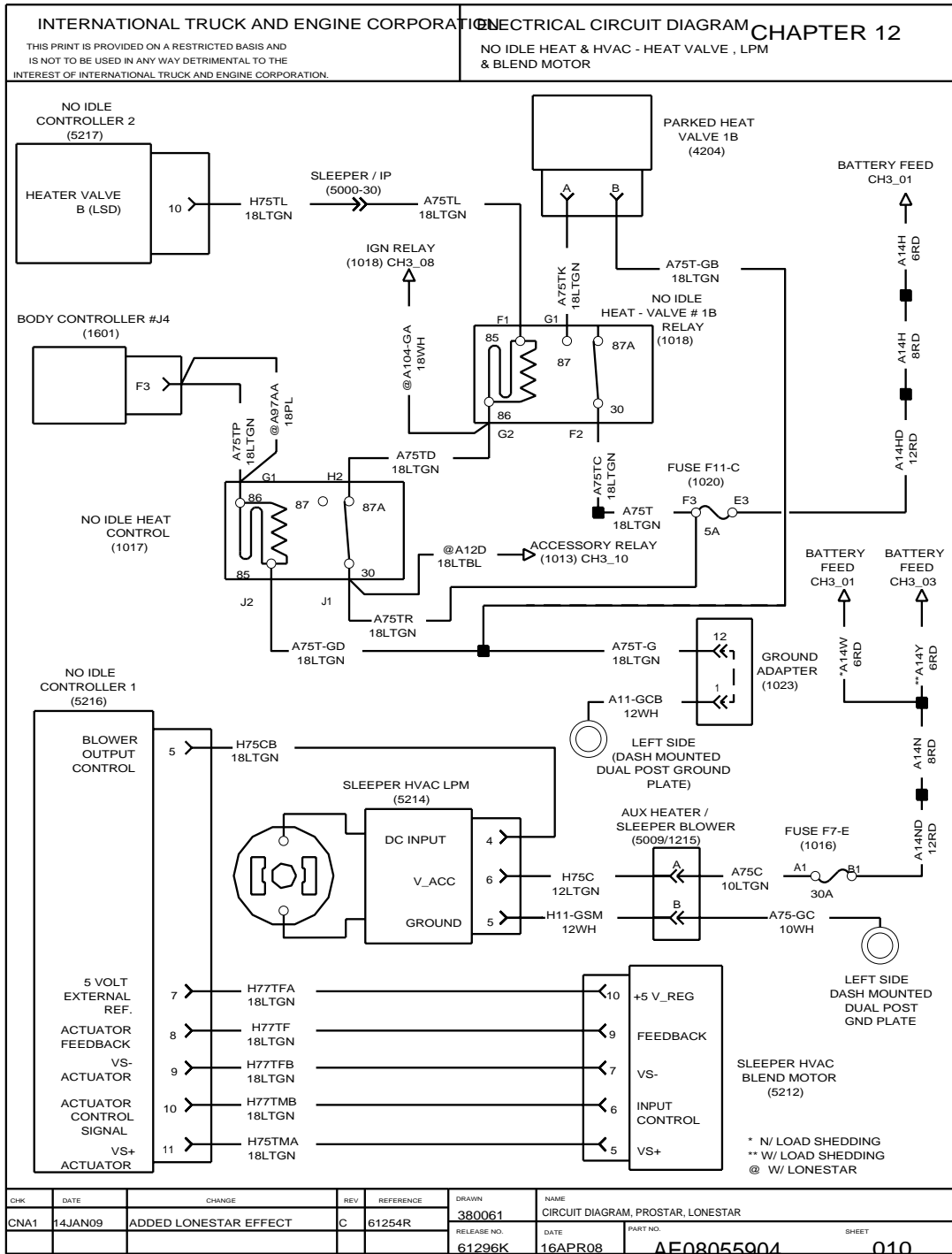


Figure 211 No Idle Heat and HVAC — Heat Valve, LPM and Blend Motor

12.12. NO IDLE HEAT AND HVAC — FUEL FIRED HEATER AND A/C COMPRESSOR, P. 11

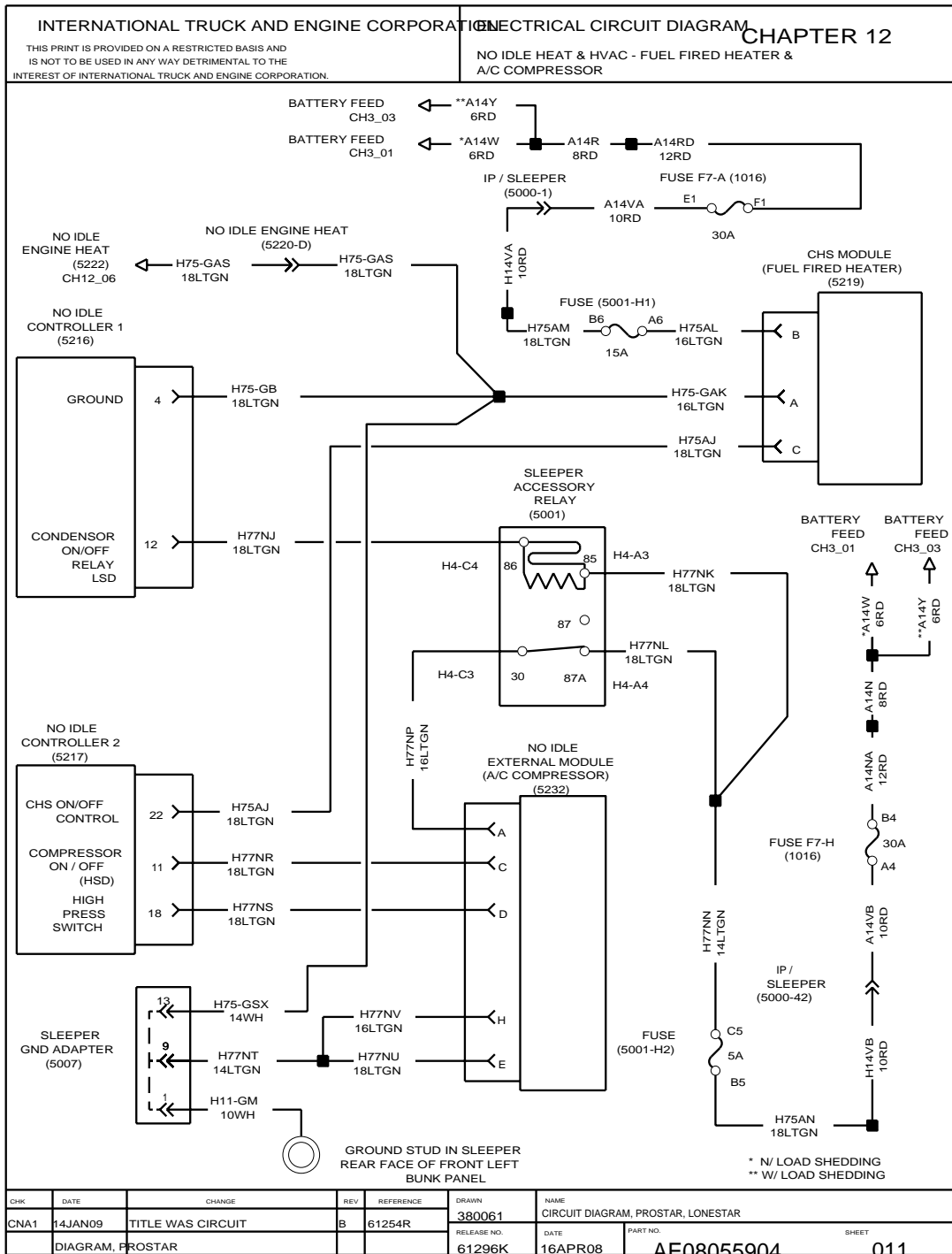


Figure 212 No Idle Heat and HVAC — Fuel Fired Heater and A/C Compressor



12.14. NO IDLE HEATER, ESPAR IN CAB FUEL FIRED HEATER, P. 13

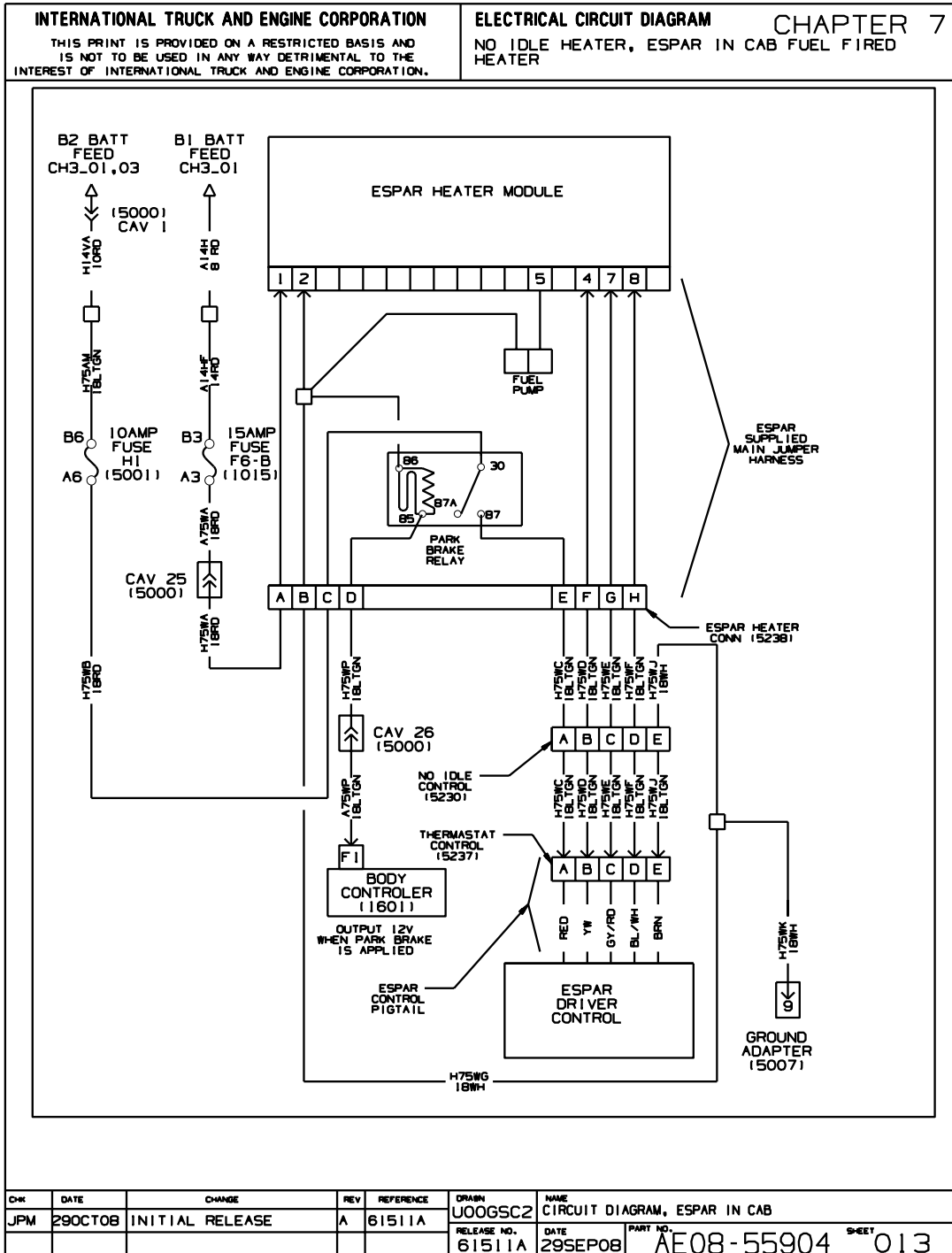


Figure 214 No Idle Heater, Espar in Cab Fuel Fired Heater

12.15. HVAC SYSTEM — SLEEPER W/BERGSTROM NO IDLE, P. 14

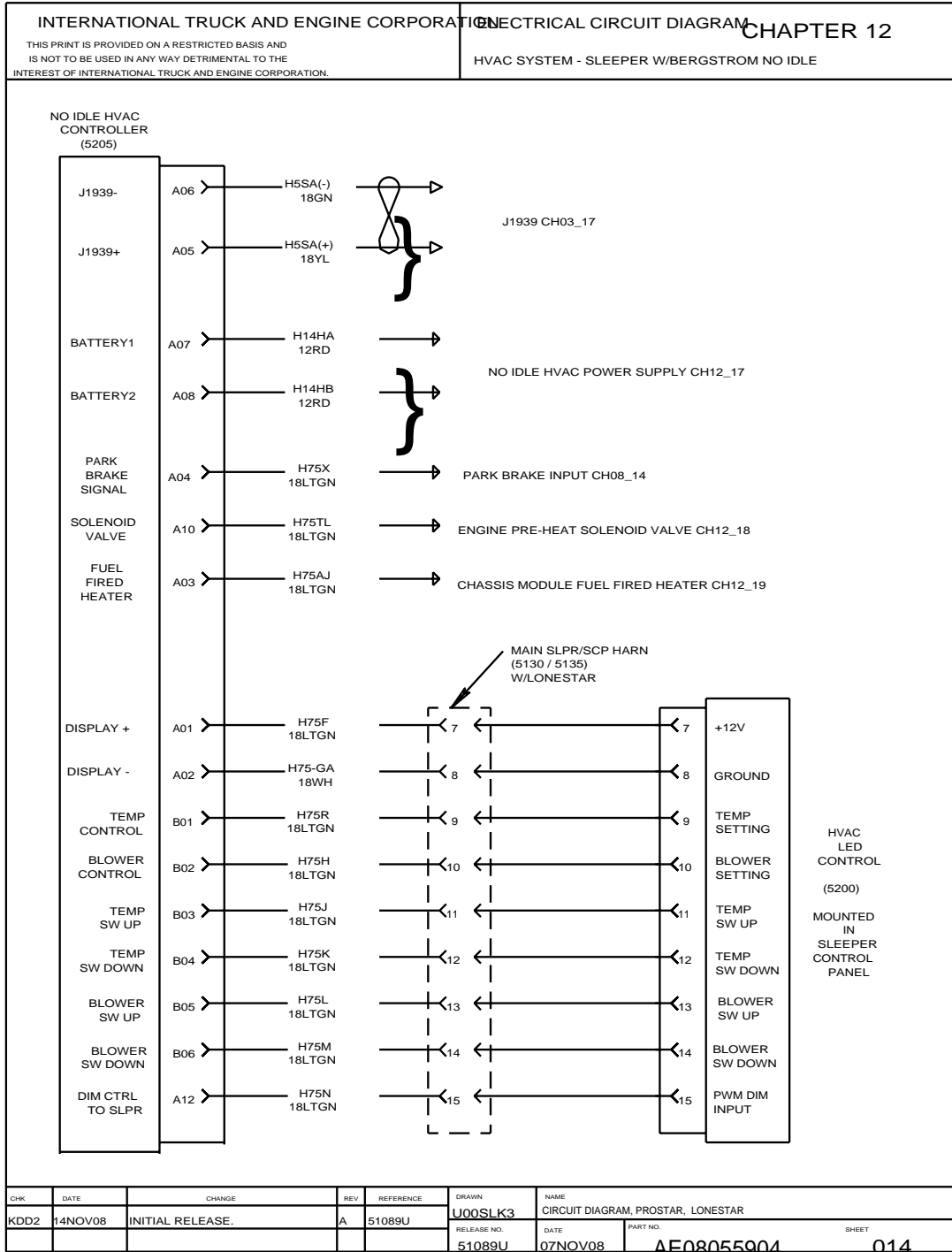


Figure 215 HVAC System — Sleeper w/Bergstrom No Idle

**12.16. NO IDLE HVAC W/BERGSTROM HVAC SWITCHES — LOCATED IN SLEEPER CONTROL PANEL, P. 15**

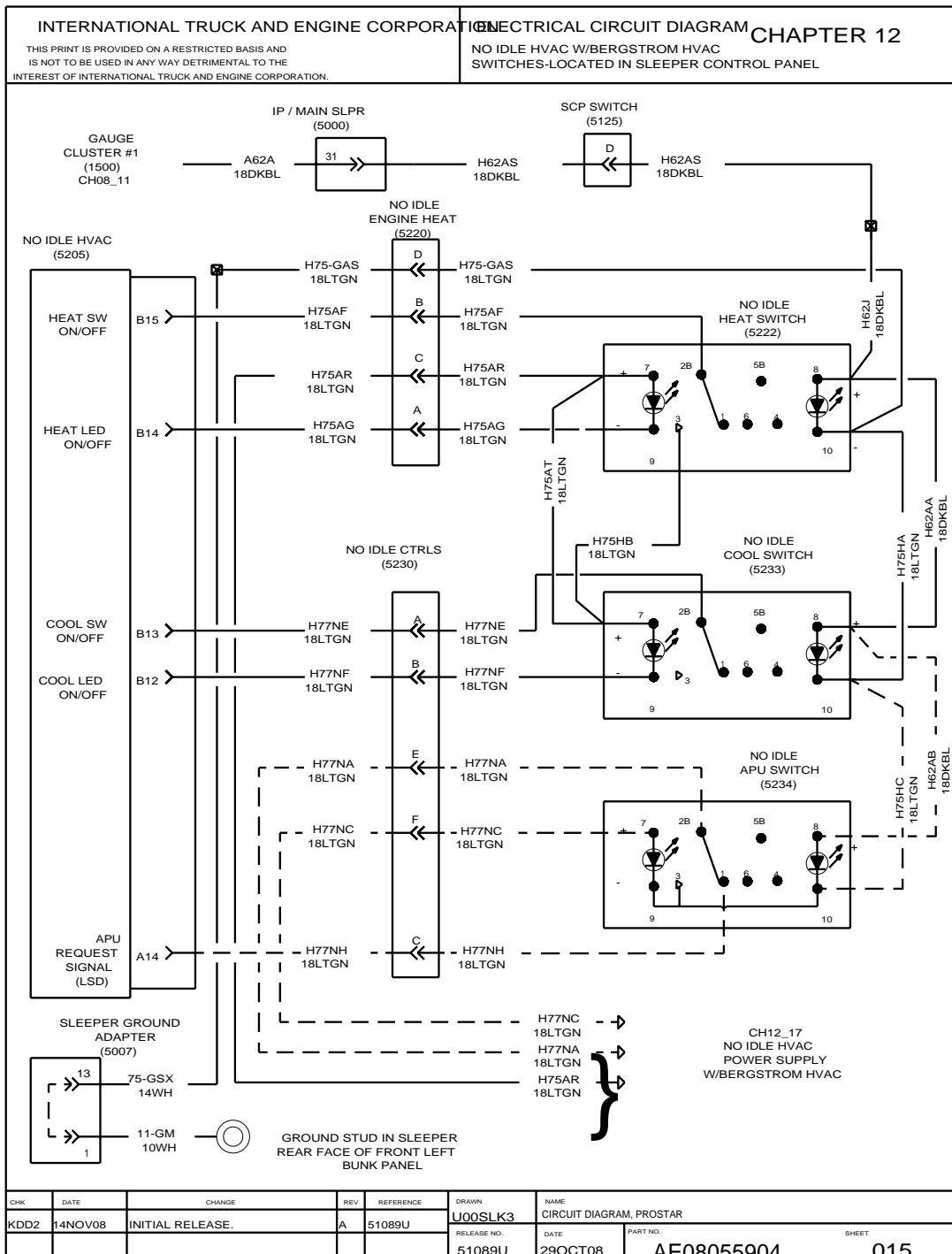


Figure 216 No Idle HVAC w/Bergstrom HVAC Switches — Located in Sleeper Control Panel

**12.17. NO IDLE HVAC W/BERGSTROM HVAC SWITCHES — LOCATED IN SLEEPER CONTROL PANEL, P. 16**

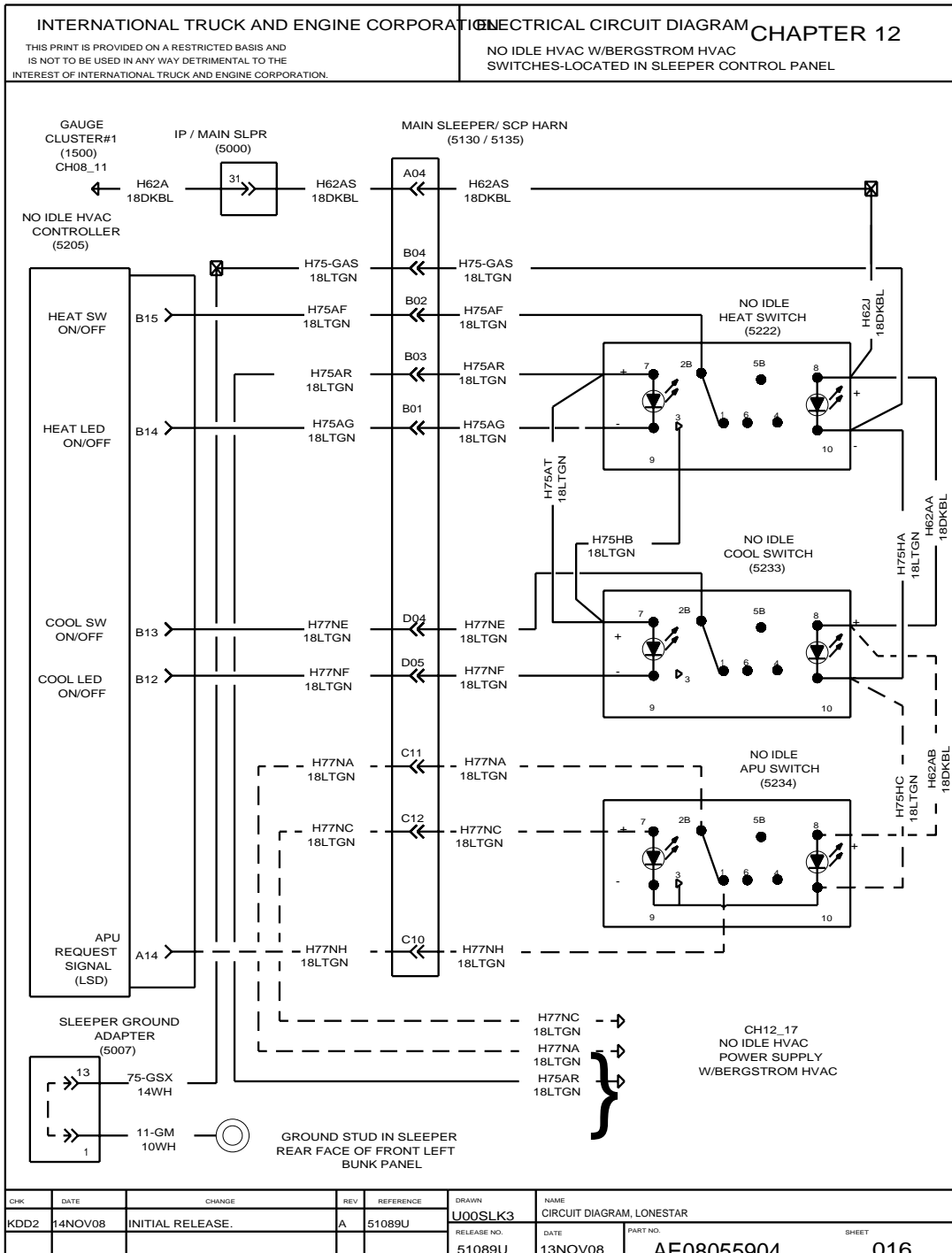


Figure 217 No Idle HVAC w/Bergstrom HVAC Switches — Located in Sleeper Control Panel

12.18. NO IDLE HVAC W/BERGSTROM HVAC POWER SUPPLY, P. 17

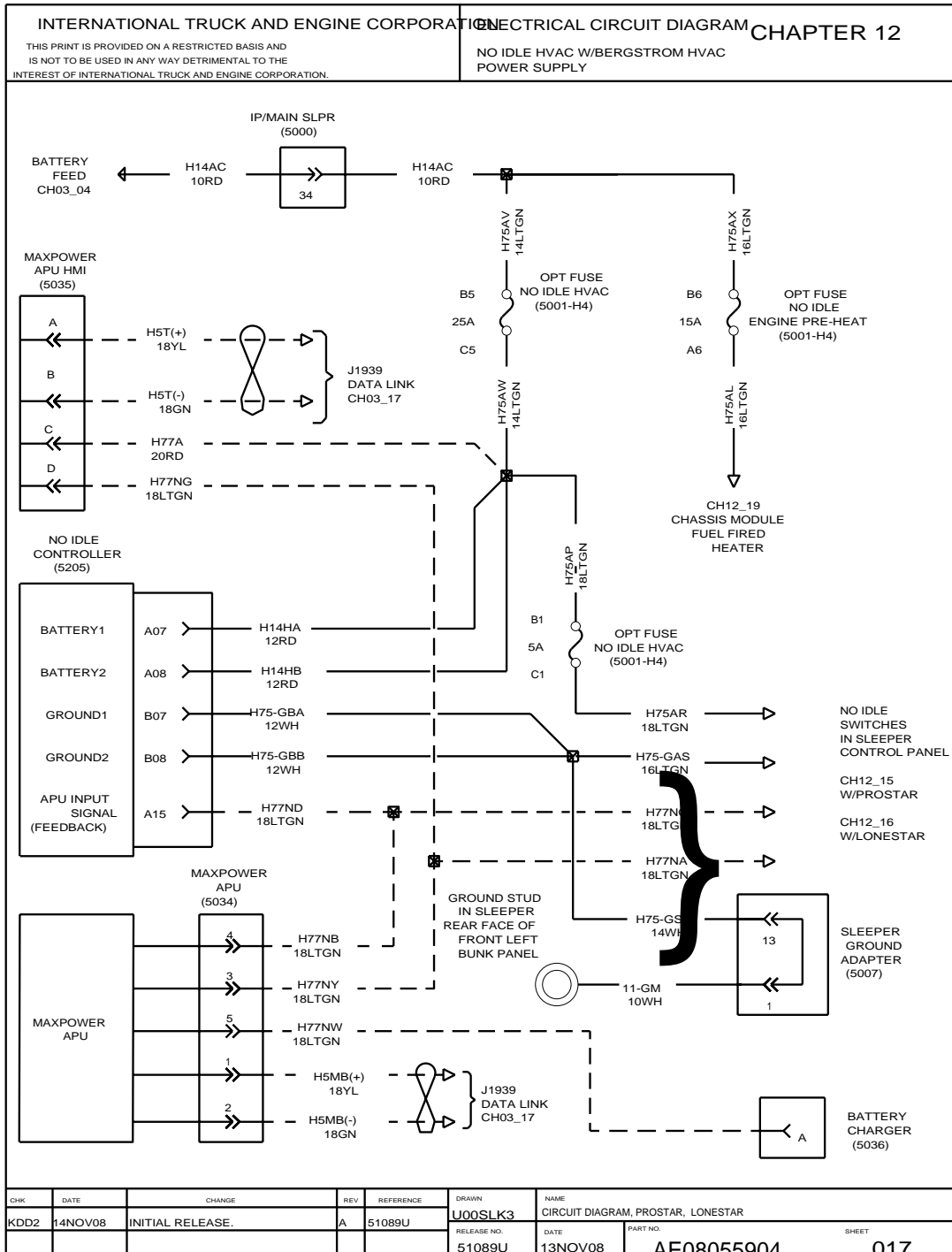


Figure 218 No Idle HVAC w/Bergstrom HVAC Power Supply

12.19. NO IDLE HVAC W/BERGSTROM ENGINE PRE-HEAT VALVE, P. 18

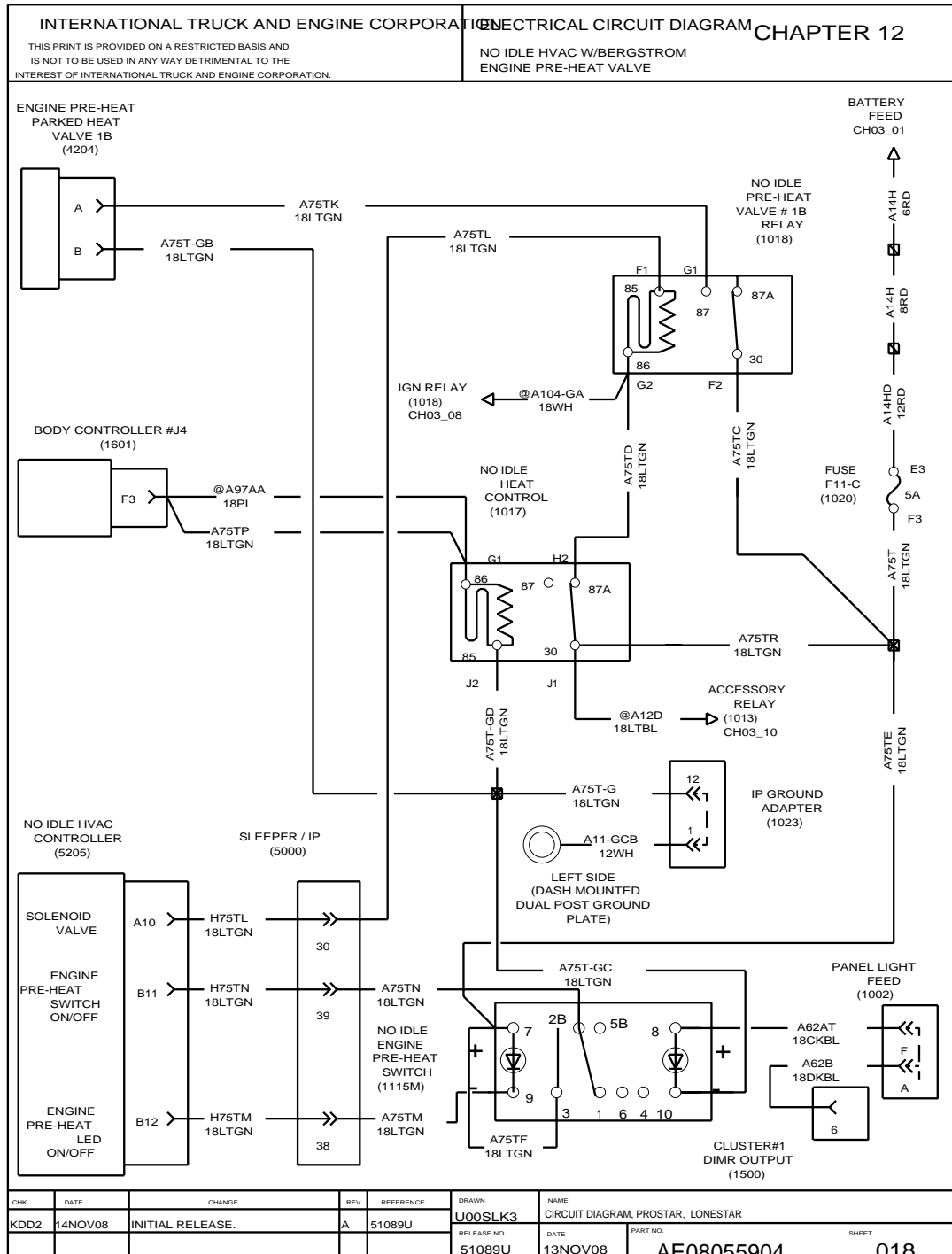


Figure 219 No Idle HVAC w/Bergstrom Engine Pre-Heat Valve

12.20. NO IDLE HVAC W/BERGSTROM FUEL FIRED HEATER, P. 19

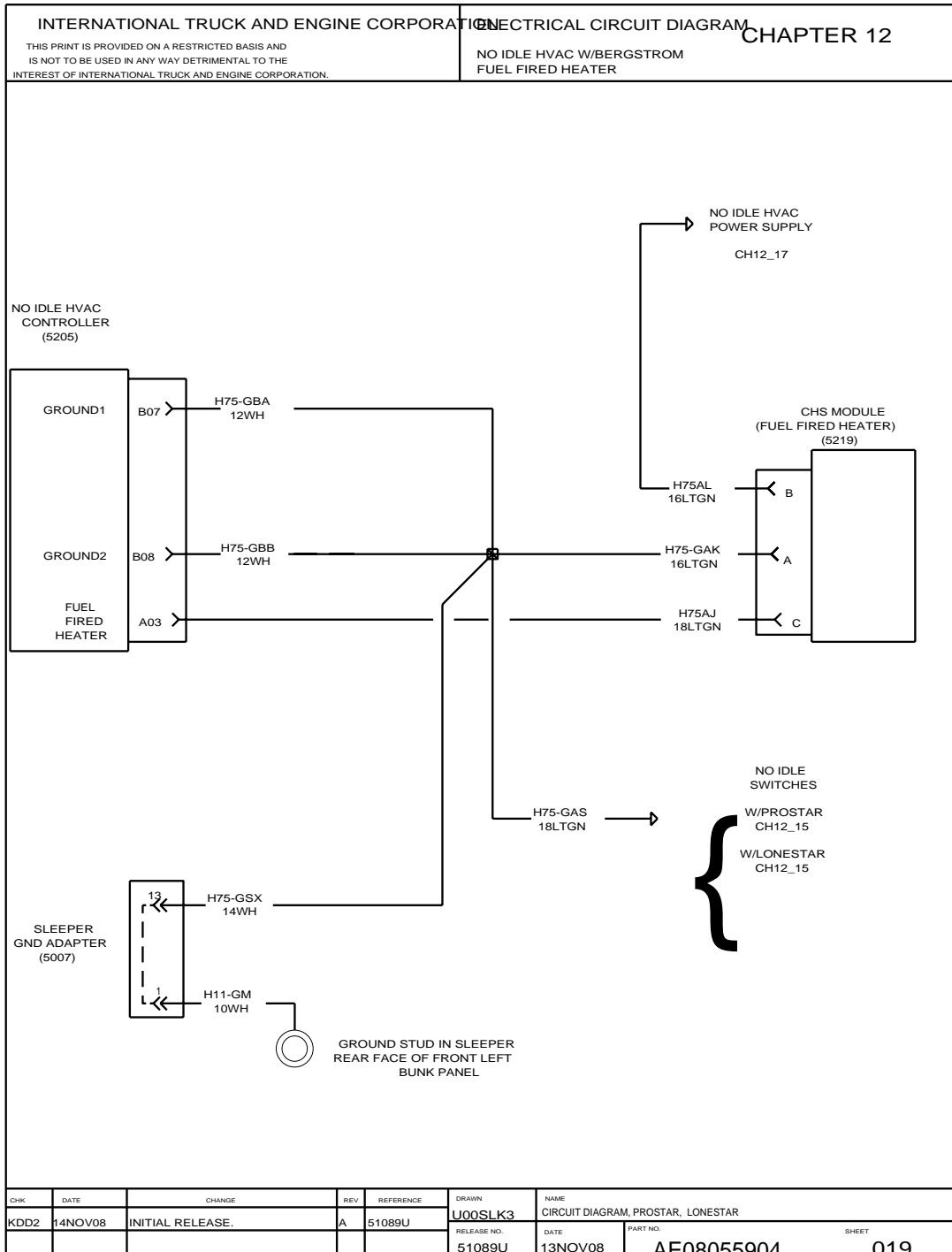


Figure 220 No Idle HVAC w/Bergstrom Fuel Fired Heater

12.21. NO IDLE HEATER, WEBASTO IN CAB FUEL FIRED HEATER N/LVD, P. 21

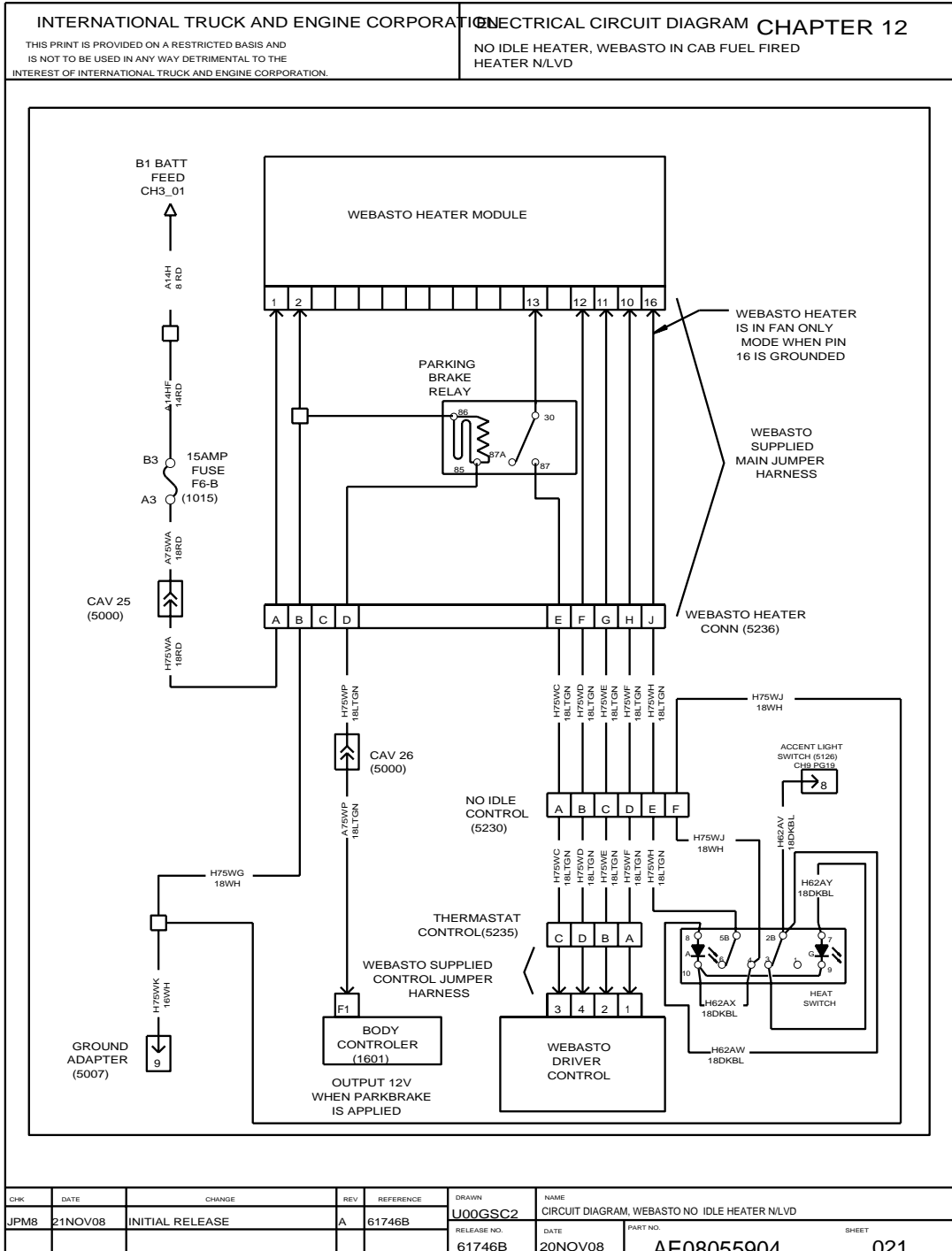


Figure 221 No Idle Heater, Webasto in Cab Fuel Fired Heater n/LVD

13. BUNK LIGHTS AND ACCESSORIES (CHAPTER 13)

13.1. READING AND WARDROBE LIGHTS — BUNK, P. 1

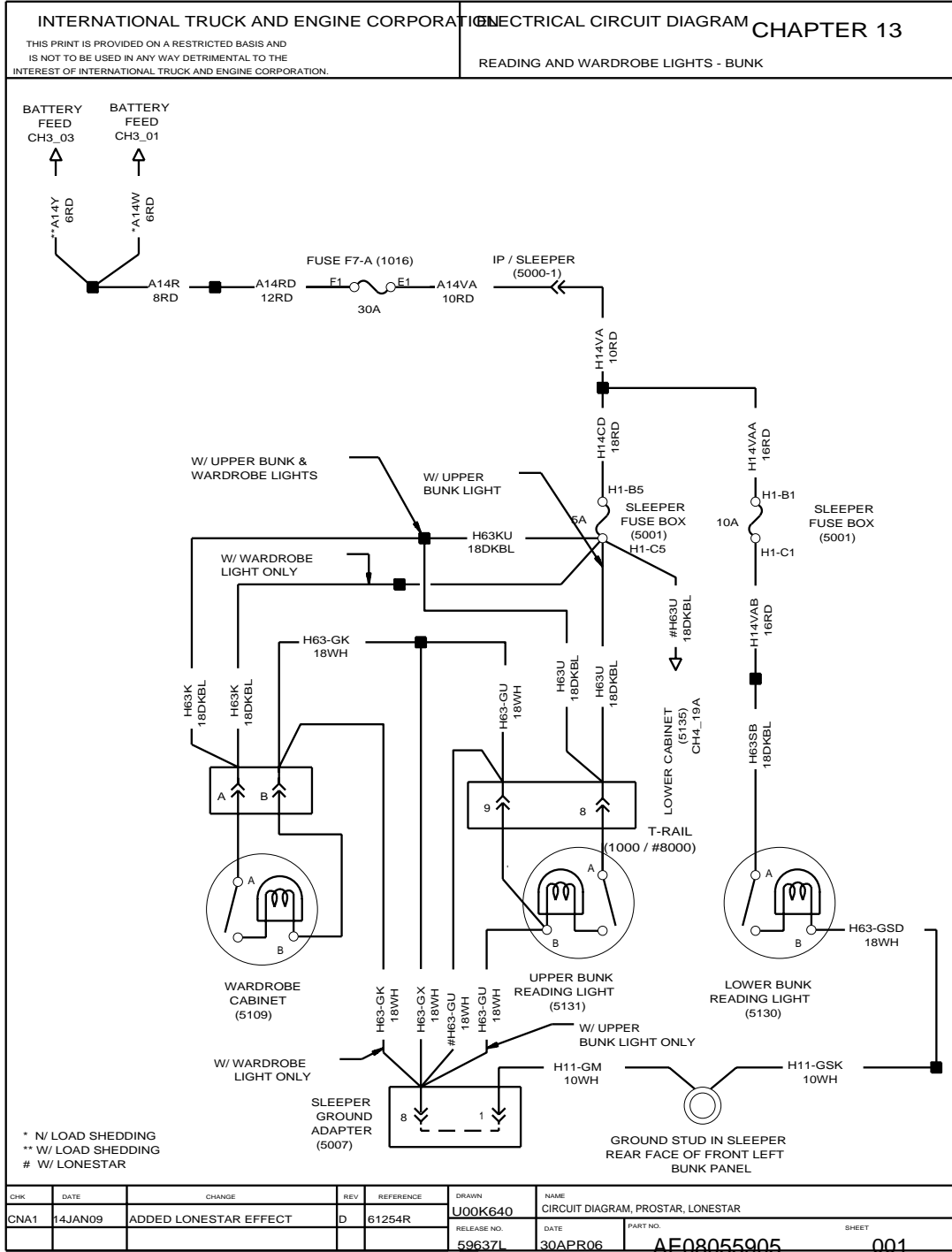


Figure 222 Reading and Wardrobe Lights — Bunk

13.2. LUGGAGE COMPARTMENT LIGHTS — BUNK, P. 2

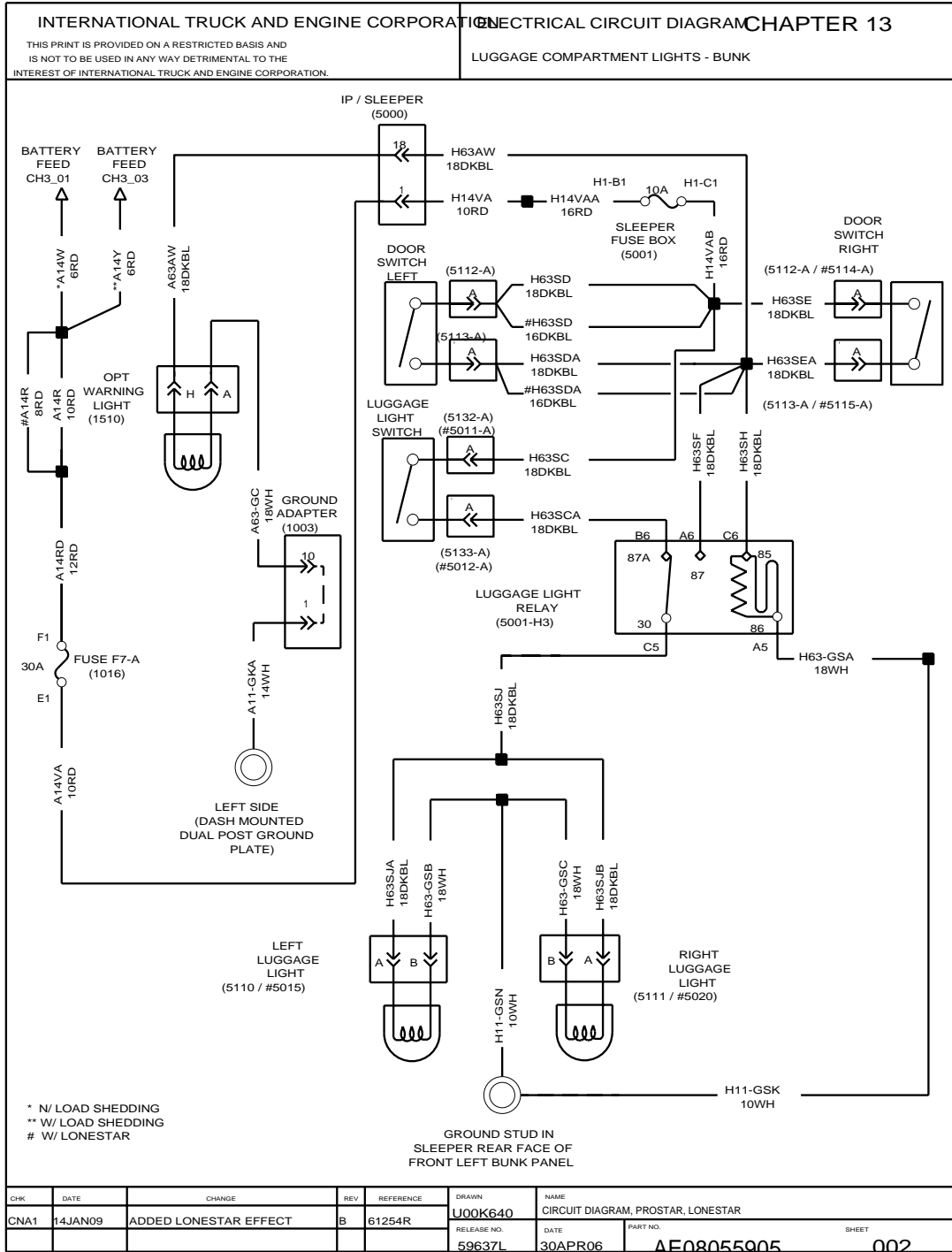


Figure 223 Luggage Compartment Lights — Bunk

13.3. POWER SOURCE — BUNK, P. 3

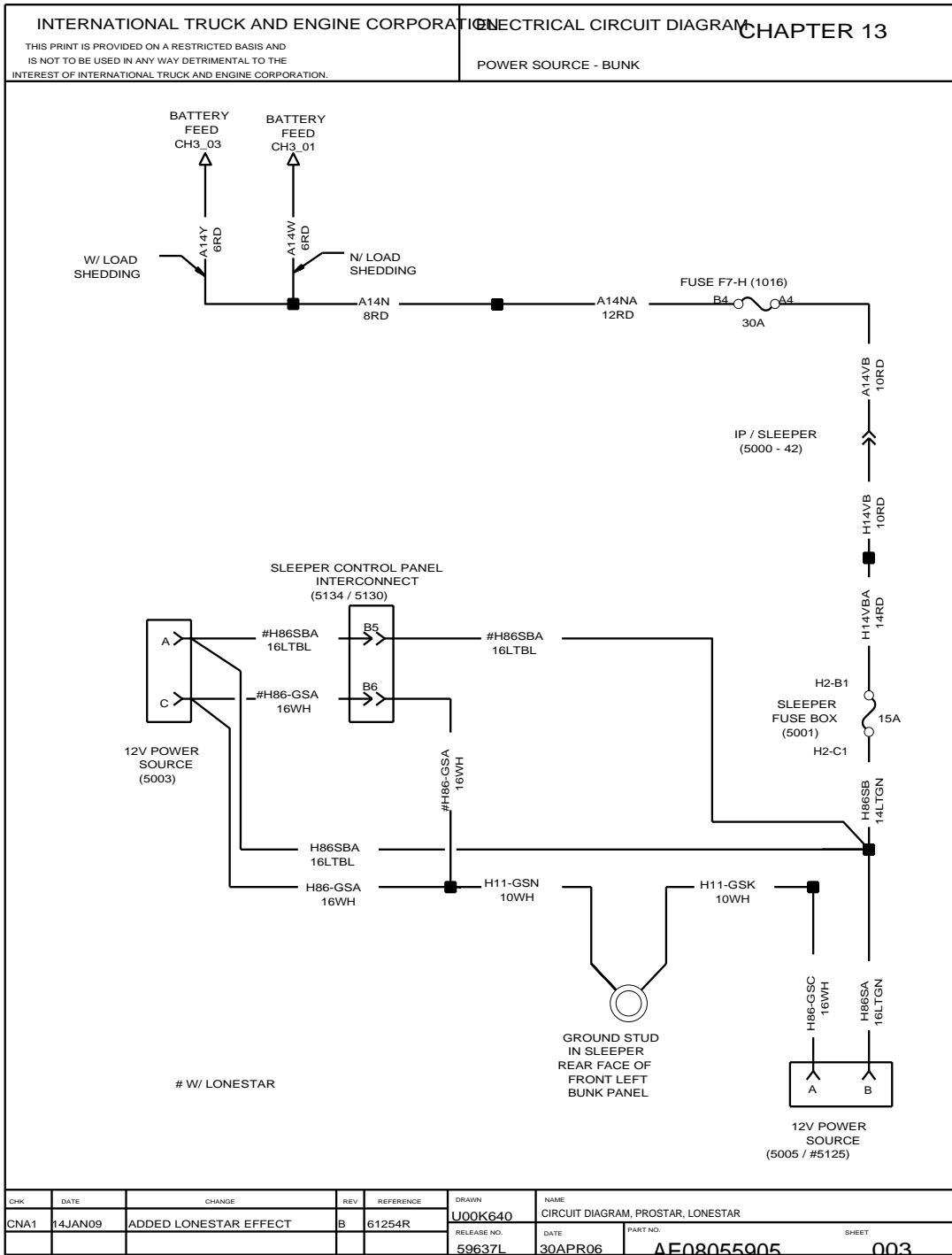


Figure 224 Power Source — Bunk

13.4. TV / REFRIGERATOR WIRING, P. 4

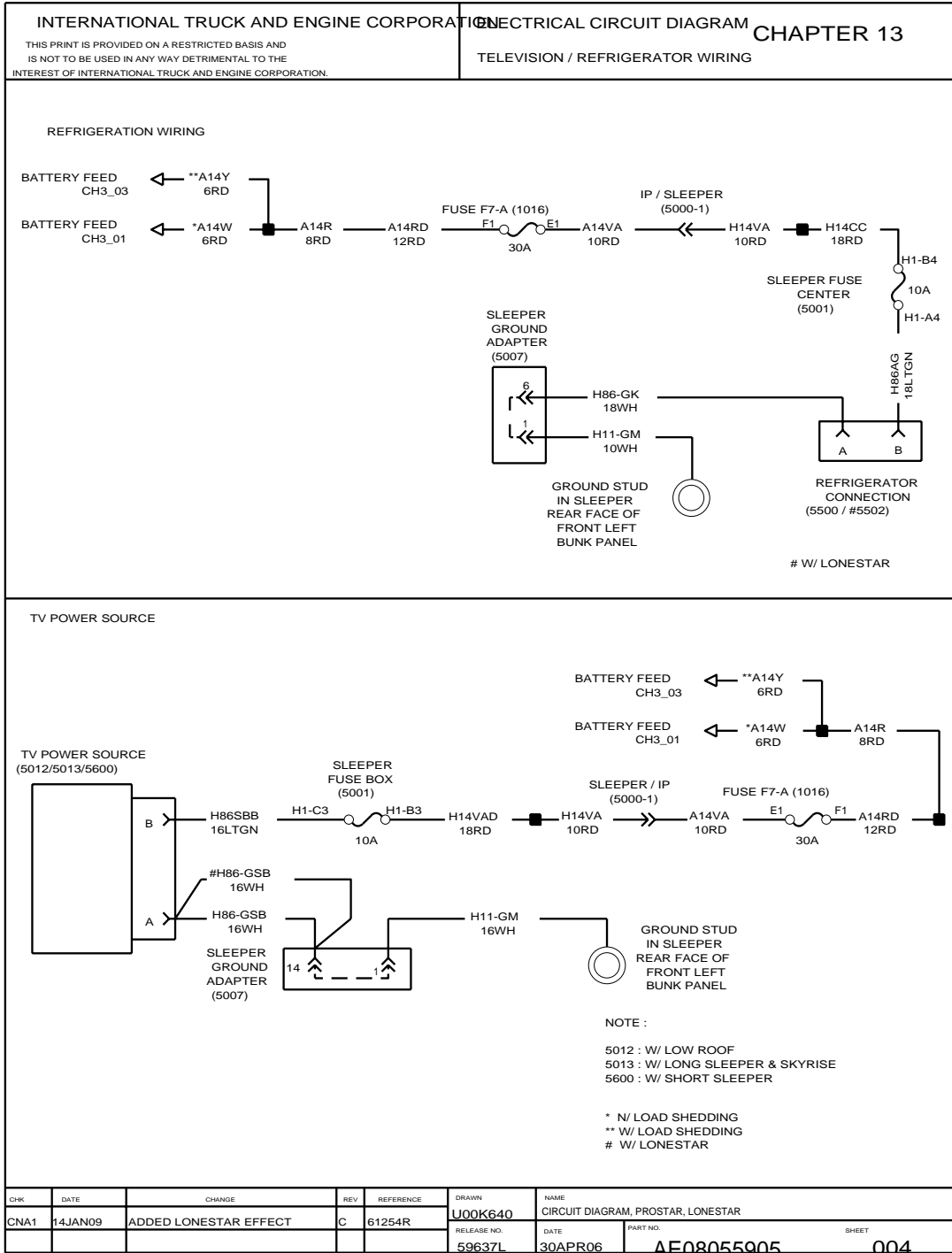


Figure 225 TV / Refrigerator Wiring

13.5. SPEAKER — BUNK, P. 5

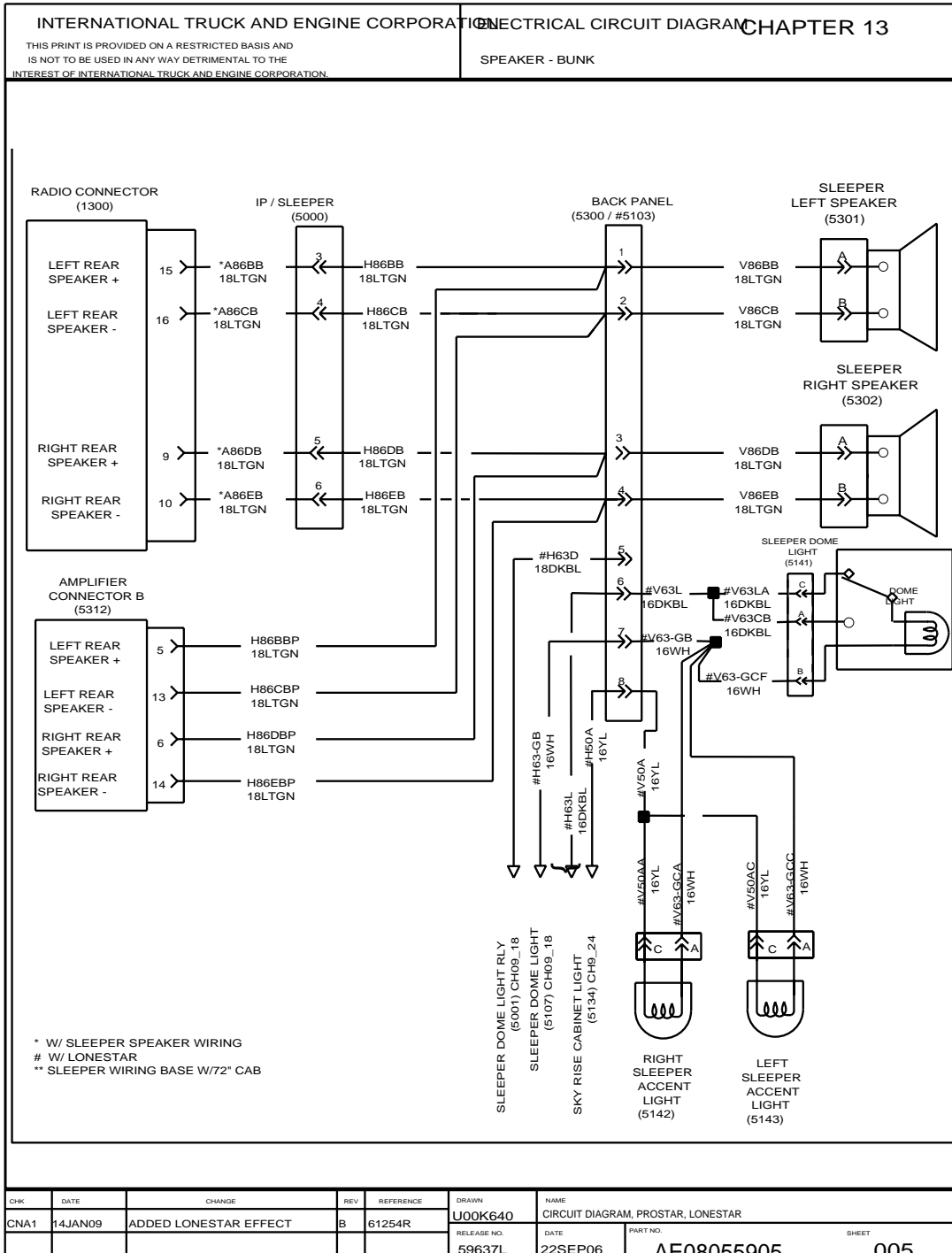


Figure 226 Speaker — Bunk

13.6. FAN — BUNK, P. 6

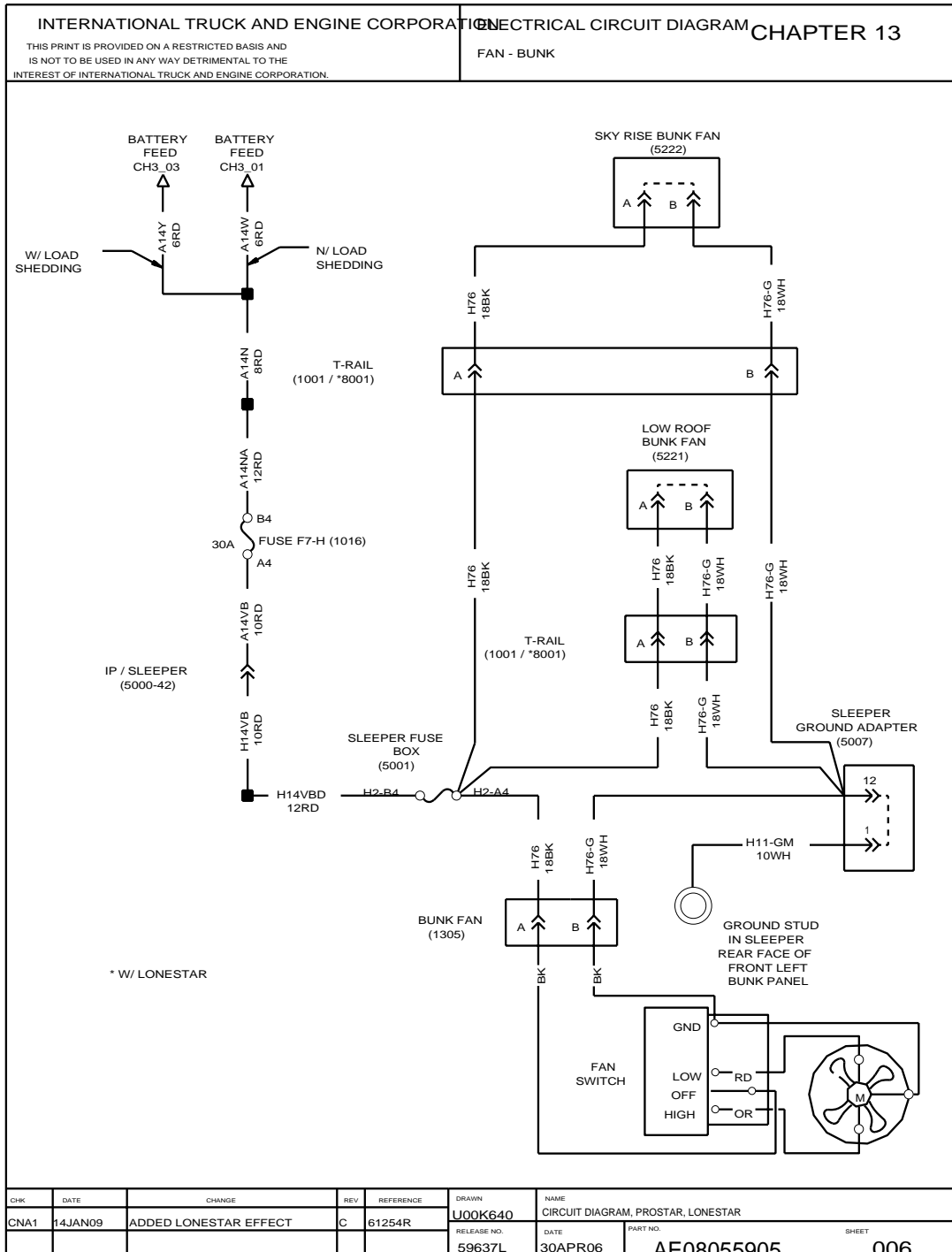


Figure 227 Fan — Bunk

13.7. SKY RISE LIGHTS — BUNK, P. 7

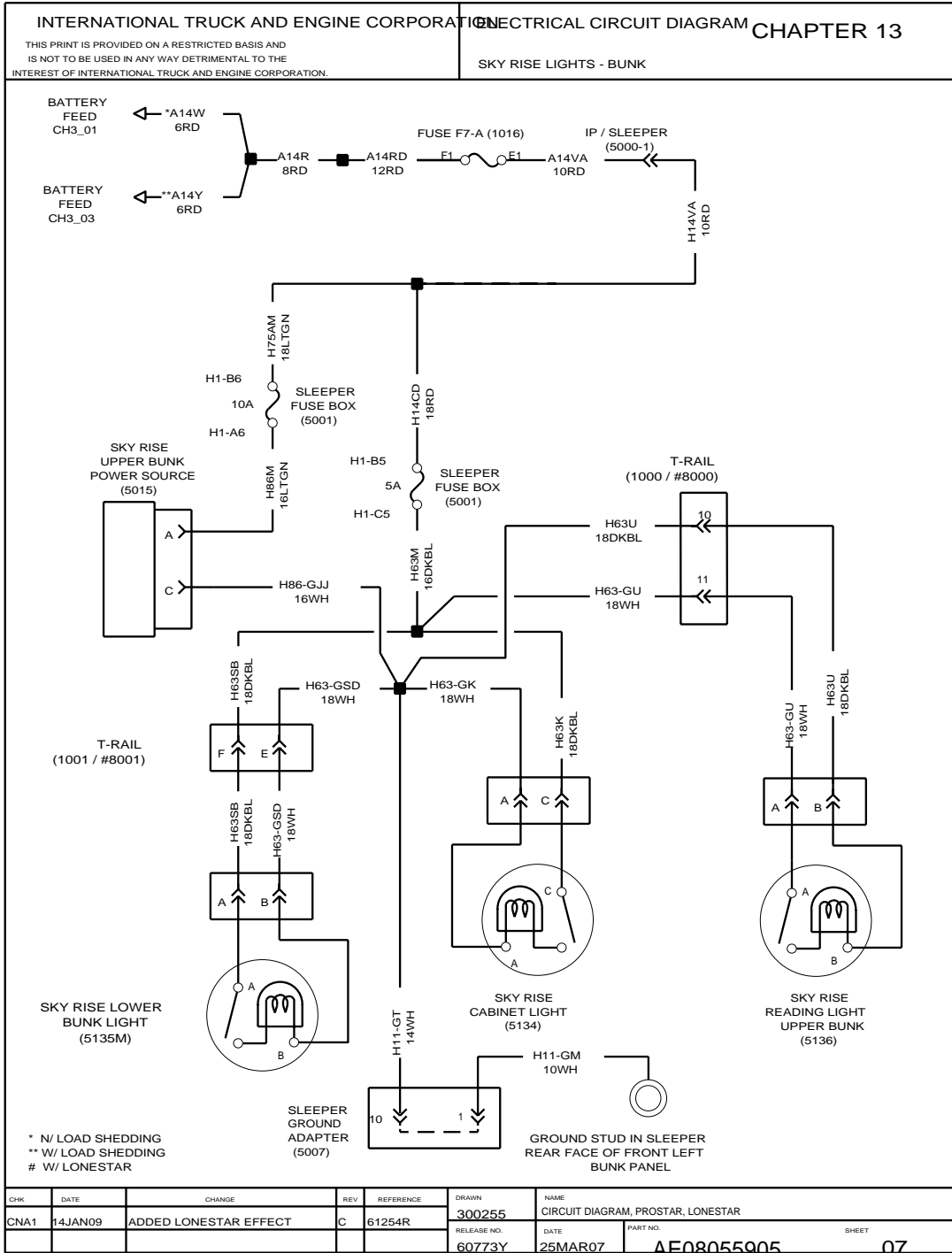


Figure 228 Sky Rise Lights — Bunk

13.8. FLAT PANEL TV/DVD PLAYER — BUNK, P. 8

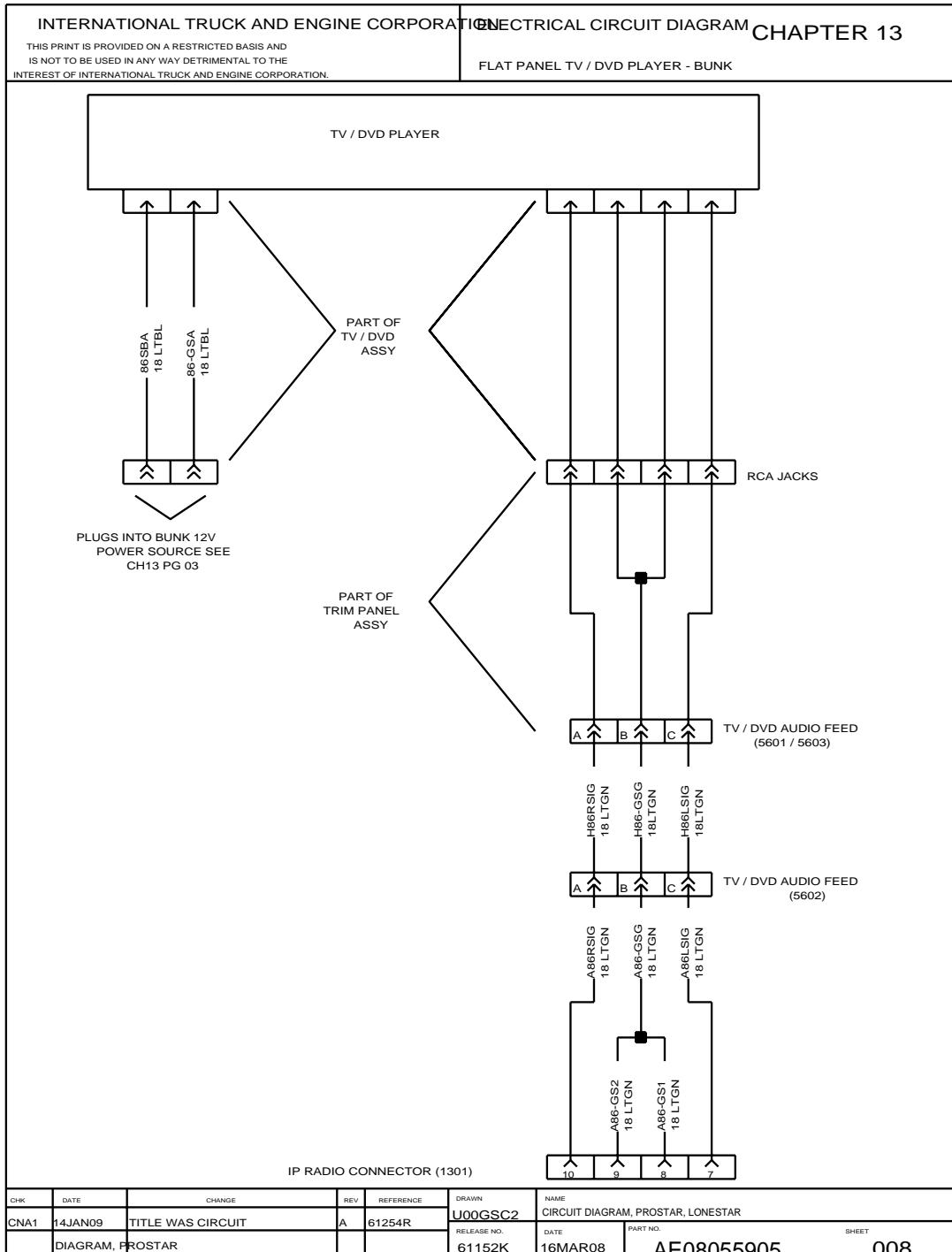


Figure 229 Flat Panel TV/DVD Player — Bunk

14. CONNECTOR COMPOSITES (CHAPTER 14)

14.1. CONNECTOR COMPOSITES (7A), (8A), (9A), (10A), P. 1

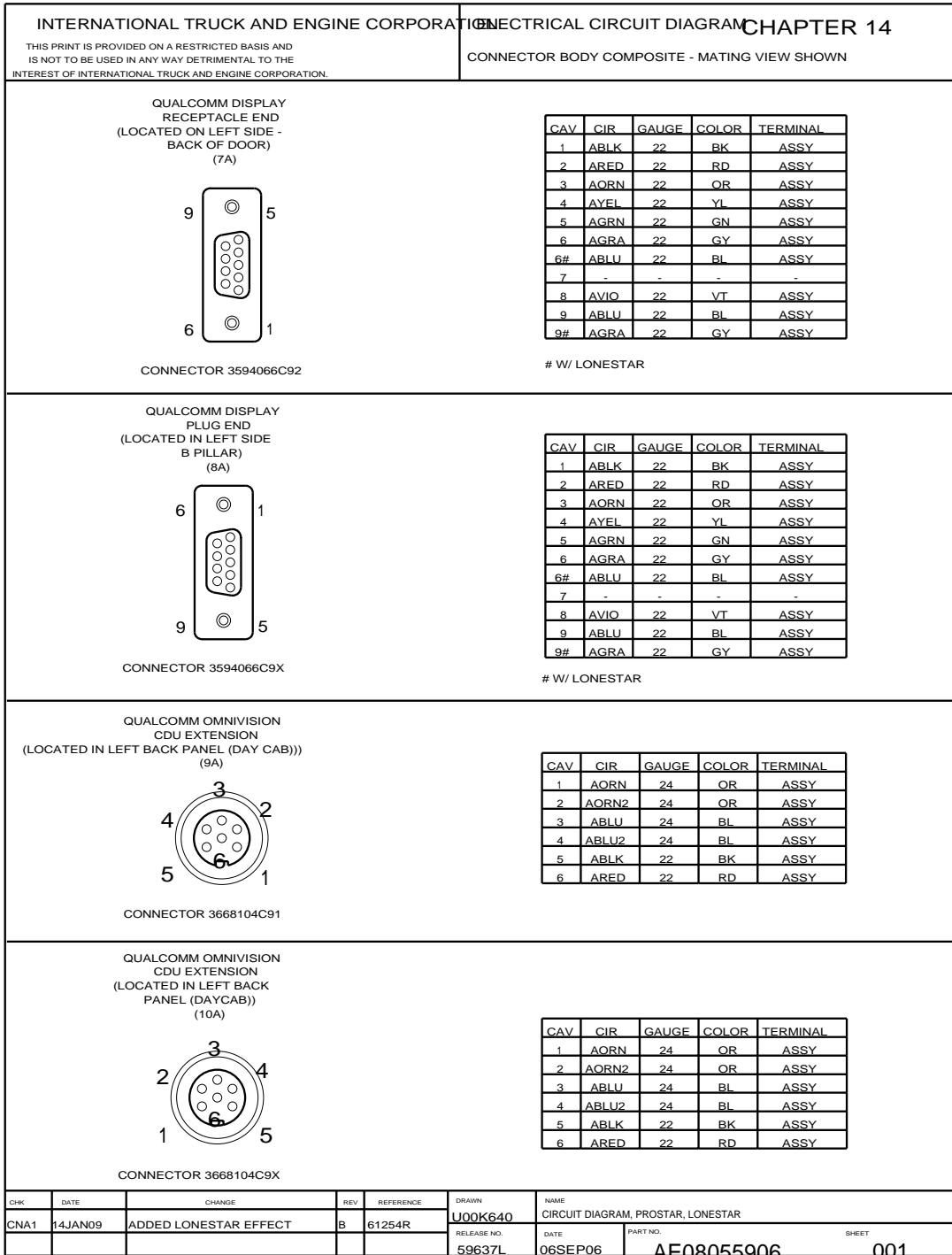


Figure 230 Connector Composites (7A), (8A), (9A), (10A)

14.2. CONNECTOR COMPOSITES (10F), (11A), (12A), (13A), P. 1A

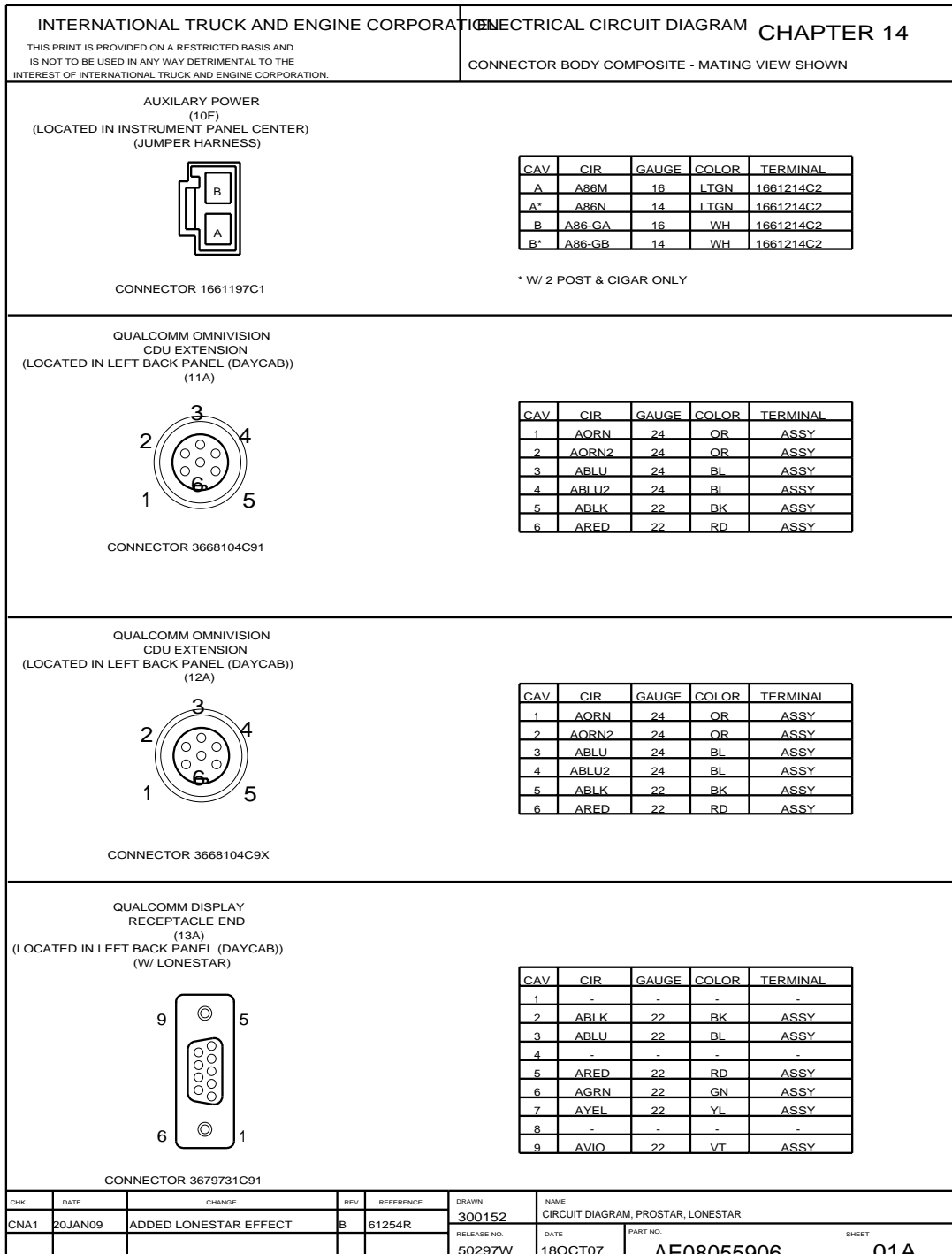


Figure 231 Connector Composites (10F), (11A), (12A), (13A)

14.3. CONNECTOR COMPOSITES (14A), (344), (345), (512), (520), P. 1B

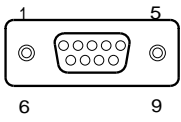



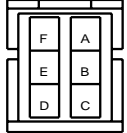

INTERNATIONAL TRUCK AND ENGINE CORPORATION <small>THIS PRINT IS PROVIDED ON A RESTRICTED BASIS AND IS NOT TO BE USED IN ANY WAY DETRIMENTAL TO THE INTEREST OF INTERNATIONAL TRUCK AND ENGINE CORPORATION.</small>		ELECTRICAL CIRCUIT DIAGRAM CHAPTER 14 CONNECTOR BODY COMPOSITE - MATING VIEW SHOWN																																																			
<p>QUALCOMM DISPLAY PLUG END (14A) (LOCATED IN LEFT BACK PANEL (DAYCAB)) (W/ LONESTAR)</p>  <p>CONNECTOR 3679731C9X</p>	<table border="1" style="width:100%; border-collapse: collapse;"> <thead> <tr> <th>CAV</th> <th>CIR</th> <th>GAUGE</th> <th>COLOR</th> <th>TERMINAL</th> </tr> </thead> <tbody> <tr><td>1</td><td>-</td><td>-</td><td>-</td><td>-</td></tr> <tr><td>2</td><td>ABLU</td><td>22</td><td>BL</td><td>ASSY</td></tr> <tr><td>3</td><td>ABLK</td><td>22</td><td>BK</td><td>ASSY</td></tr> <tr><td>4</td><td>-</td><td>-</td><td>-</td><td>-</td></tr> <tr><td>5</td><td>ARED</td><td>22</td><td>RD</td><td>ASSY</td></tr> <tr><td>6</td><td>AGRN</td><td>22</td><td>GN</td><td>ASSY</td></tr> <tr><td>7</td><td>AYEL</td><td>22</td><td>YL</td><td>ASSY</td></tr> <tr><td>8</td><td>-</td><td>-</td><td>-</td><td>-</td></tr> <tr><td>9</td><td>AVIO</td><td>22</td><td>VT</td><td>ASSY</td></tr> </tbody> </table>			CAV	CIR	GAUGE	COLOR	TERMINAL	1	-	-	-	-	2	ABLU	22	BL	ASSY	3	ABLK	22	BK	ASSY	4	-	-	-	-	5	ARED	22	RD	ASSY	6	AGRN	22	GN	ASSY	7	AYEL	22	YL	ASSY	8	-	-	-	-	9	AVIO	22	VT	ASSY
CAV	CIR	GAUGE	COLOR	TERMINAL																																																	
1	-	-	-	-																																																	
2	ABLU	22	BL	ASSY																																																	
3	ABLK	22	BK	ASSY																																																	
4	-	-	-	-																																																	
5	ARED	22	RD	ASSY																																																	
6	AGRN	22	GN	ASSY																																																	
7	AYEL	22	YL	ASSY																																																	
8	-	-	-	-																																																	
9	AVIO	22	VT	ASSY																																																	
<p>CB SPEAKER (344) (LOCATED IN INSTRUMENT PANEL BY DRIVER) (W/ LONESTAR)</p>  <p>CONNECTOR 1661196C1</p>	<table border="1" style="width:100%; border-collapse: collapse;"> <thead> <tr> <th>CAV</th> <th>CIR</th> <th>GAUGE</th> <th>COLOR</th> <th>TERMINAL</th> </tr> </thead> <tbody> <tr><td>A</td><td>A86H</td><td>18</td><td>LTGN</td><td>1661208C1</td></tr> <tr><td>B</td><td>A86J</td><td>18</td><td>LTGN</td><td>1661208C1</td></tr> </tbody> </table>			CAV	CIR	GAUGE	COLOR	TERMINAL	A	A86H	18	LTGN	1661208C1	B	A86J	18	LTGN	1661208C1																																			
CAV	CIR	GAUGE	COLOR	TERMINAL																																																	
A	A86H	18	LTGN	1661208C1																																																	
B	A86J	18	LTGN	1661208C1																																																	
<p>SUNSHADE (345) (LOCATED IN ROOF WIRING FRONT W/ SUNSHADE)</p>  <p>CONNECTOR 1661259C1 BODY LOCK 1661263C1</p>	 <p>CONNECTOR 1661260C1 BODY LOCK 1661264C1</p> <table border="1" style="width:100%; border-collapse: collapse;"> <thead> <tr> <th>CAV</th> <th>CIR</th> <th>GAUGE</th> <th>COLOR</th> <th>TERMINAL</th> </tr> </thead> <tbody> <tr><td>A</td><td>D58T</td><td>18</td><td>BN</td><td>1661262C1</td></tr> <tr><td>B</td><td>D58-GL</td><td>18</td><td>WH</td><td>1661262C1</td></tr> </tbody> </table>			CAV	CIR	GAUGE	COLOR	TERMINAL	A	D58T	18	BN	1661262C1	B	D58-GL	18	WH	1661262C1																																			
CAV	CIR	GAUGE	COLOR	TERMINAL																																																	
A	D58T	18	BN	1661262C1																																																	
B	D58-GL	18	WH	1661262C1																																																	
<p>ACCENT LIGHT DIMMER (512) (LOCATED ON SLEEPER CONTROL PANEL)</p>  <p>CONNECTOR 16611200C1</p>	<table border="1" style="width:100%; border-collapse: collapse;"> <thead> <tr> <th>CAV</th> <th>CIR</th> <th>GAUGE</th> <th>COLOR</th> <th>TERMINAL</th> </tr> </thead> <tbody> <tr><td>A</td><td>C63A</td><td>18</td><td>DKBL</td><td>1661208C1</td></tr> <tr><td>B</td><td>C63-GA</td><td>18</td><td>DKBL</td><td>1661208C1</td></tr> <tr><td>C</td><td>C63B</td><td>18</td><td>DKBL</td><td>1661208C1</td></tr> <tr><td>D*</td><td>C62B</td><td>18</td><td>DKBL</td><td>1661209C1</td></tr> <tr><td>D#</td><td>C62D</td><td>18</td><td>DKBL</td><td>1661209C1</td></tr> <tr><td>E</td><td>-</td><td>-</td><td>-</td><td>-</td></tr> <tr><td>F</td><td>C62-GB</td><td>18</td><td>DKBL</td><td>1661208C1</td></tr> </tbody> </table> <p>* W/ ACCENT LIGHT ON / OFF # W/ DOME LIGHT ON / OFF</p>			CAV	CIR	GAUGE	COLOR	TERMINAL	A	C63A	18	DKBL	1661208C1	B	C63-GA	18	DKBL	1661208C1	C	C63B	18	DKBL	1661208C1	D*	C62B	18	DKBL	1661209C1	D#	C62D	18	DKBL	1661209C1	E	-	-	-	-	F	C62-GB	18	DKBL	1661208C1										
CAV	CIR	GAUGE	COLOR	TERMINAL																																																	
A	C63A	18	DKBL	1661208C1																																																	
B	C63-GA	18	DKBL	1661208C1																																																	
C	C63B	18	DKBL	1661208C1																																																	
D*	C62B	18	DKBL	1661209C1																																																	
D#	C62D	18	DKBL	1661209C1																																																	
E	-	-	-	-																																																	
F	C62-GB	18	DKBL	1661208C1																																																	
<p>CLEARANCE LIGHT (520) (LOCATED IN SUNSHADE)</p>  <p>CONNECTOR 1661259C1 BODY LOCK 1661263C1</p>	<table border="1" style="width:100%; border-collapse: collapse;"> <thead> <tr> <th>CAV</th> <th>CIR</th> <th>GAUGE</th> <th>COLOR</th> <th>TERMINAL</th> </tr> </thead> <tbody> <tr><td>A</td><td>C58B</td><td>18</td><td>BN</td><td>1661261C1</td></tr> <tr><td>B</td><td>C58-GB</td><td>18</td><td>WH</td><td>1661261C1</td></tr> </tbody> </table>			CAV	CIR	GAUGE	COLOR	TERMINAL	A	C58B	18	BN	1661261C1	B	C58-GB	18	WH	1661261C1																																			
CAV	CIR	GAUGE	COLOR	TERMINAL																																																	
A	C58B	18	BN	1661261C1																																																	
B	C58-GB	18	WH	1661261C1																																																	
<table border="1" style="width:100%; border-collapse: collapse;"> <thead> <tr> <th>CHK</th> <th>DATE</th> <th>CHANGE</th> <th>REV</th> <th>REFERENCE</th> </tr> </thead> <tbody> <tr> <td>CNA1</td> <td>14JAN09</td> <td>INITIAL RELEASE</td> <td>A</td> <td>61254R</td> </tr> </tbody> </table>	CHK	DATE	CHANGE	REV	REFERENCE	CNA1	14JAN09	INITIAL RELEASE	A	61254R	<table border="1" style="width:100%; border-collapse: collapse;"> <thead> <tr> <th>DRAWN</th> <th>NAME</th> </tr> </thead> <tbody> <tr> <td>300525</td> <td>CIRCUIT DIAGRAM, PROSTAR, LONESTAR</td> </tr> </tbody> </table>	DRAWN	NAME	300525	CIRCUIT DIAGRAM, PROSTAR, LONESTAR	<table border="1" style="width:100%; border-collapse: collapse;"> <thead> <tr> <th>RELEASE NO.</th> <th>DATE</th> <th>PART NO.</th> <th>SHEET</th> </tr> </thead> <tbody> <tr> <td>61254R</td> <td>15SEP08</td> <td>AE08055906</td> <td>01B</td> </tr> </tbody> </table>	RELEASE NO.	DATE	PART NO.	SHEET	61254R	15SEP08	AE08055906	01B																													
CHK	DATE	CHANGE	REV	REFERENCE																																																	
CNA1	14JAN09	INITIAL RELEASE	A	61254R																																																	
DRAWN	NAME																																																				
300525	CIRCUIT DIAGRAM, PROSTAR, LONESTAR																																																				
RELEASE NO.	DATE	PART NO.	SHEET																																																		
61254R	15SEP08	AE08055906	01B																																																		

Figure 232 Connector Composites (14A), (344), (345), (512), (520)

14.4. CONNECTOR COMPOSITES (521), (522), (523), (524), P. 2





INTERNATIONAL TRUCK AND ENGINE CORPORATION				ELECTRICAL CIRCUIT DIAGRAM CHAPTER 14																		
THIS PRINT IS PROVIDED ON A RESTRICTED BASIS AND IS NOT TO BE USED IN ANY WAY DETRIMENTAL TO THE INTEREST OF INTERNATIONAL TRUCK AND ENGINE CORPORATION.				CONNECTOR BODY COMPOSITE - MATING VIEW SHOWN																		
CLEARANCE LIGHT (521) (LOCATED IN SUNSHADE) (W/ PROSTAR)																						
				<table border="1" style="width:100%; border-collapse: collapse;"> <thead> <tr> <th>CAV</th> <th>CIR</th> <th>GAUGE</th> <th>COLOR</th> <th>TERMINAL</th> </tr> </thead> <tbody> <tr> <td>A</td> <td>C58C</td> <td>18</td> <td>BN</td> <td>1661261C1</td> </tr> <tr> <td>B</td> <td>C58-GC</td> <td>18</td> <td>WH</td> <td>1661261C1</td> </tr> </tbody> </table>				CAV	CIR	GAUGE	COLOR	TERMINAL	A	C58C	18	BN	1661261C1	B	C58-GC	18	WH	1661261C1
CAV	CIR	GAUGE	COLOR	TERMINAL																		
A	C58C	18	BN	1661261C1																		
B	C58-GC	18	WH	1661261C1																		
CONNECTOR 1661259C1 BODY LOCK 1661263C1																						
CLEARANCE LIGHT (522) (LOCATED IN SUNSHADE) (W/ PROSTAR)																						
				<table border="1" style="width:100%; border-collapse: collapse;"> <thead> <tr> <th>CAV</th> <th>CIR</th> <th>GAUGE</th> <th>COLOR</th> <th>TERMINAL</th> </tr> </thead> <tbody> <tr> <td>A</td> <td>C58D</td> <td>18</td> <td>BN</td> <td>1661261C1</td> </tr> <tr> <td>B</td> <td>C58-GD</td> <td>18</td> <td>WH</td> <td>1661261C1</td> </tr> </tbody> </table>				CAV	CIR	GAUGE	COLOR	TERMINAL	A	C58D	18	BN	1661261C1	B	C58-GD	18	WH	1661261C1
CAV	CIR	GAUGE	COLOR	TERMINAL																		
A	C58D	18	BN	1661261C1																		
B	C58-GD	18	WH	1661261C1																		
CONNECTOR 1661259C1 BODY LOCK 1661263C1																						
CLEARANCE LIGHT (523) (LOCATED IN SUNSHADE) (W/ PROSTAR)																						
				<table border="1" style="width:100%; border-collapse: collapse;"> <thead> <tr> <th>CAV</th> <th>CIR</th> <th>GAUGE</th> <th>COLOR</th> <th>TERMINAL</th> </tr> </thead> <tbody> <tr> <td>A</td> <td>C58E</td> <td>18</td> <td>BN</td> <td>1661261C1</td> </tr> <tr> <td>B</td> <td>C58-GE</td> <td>18</td> <td>WH</td> <td>1661261C1</td> </tr> </tbody> </table>				CAV	CIR	GAUGE	COLOR	TERMINAL	A	C58E	18	BN	1661261C1	B	C58-GE	18	WH	1661261C1
CAV	CIR	GAUGE	COLOR	TERMINAL																		
A	C58E	18	BN	1661261C1																		
B	C58-GE	18	WH	1661261C1																		
CONNECTOR 1661259C1 BODY LOCK 1661263C1																						
CLEARANCE LIGHT (524) (LOCATED IN SUNSHADE) (W/ PROSTAR)																						
				<table border="1" style="width:100%; border-collapse: collapse;"> <thead> <tr> <th>CAV</th> <th>CIR</th> <th>GAUGE</th> <th>COLOR</th> <th>TERMINAL</th> </tr> </thead> <tbody> <tr> <td>A</td> <td>C58F</td> <td>18</td> <td>BN</td> <td>1661261C1</td> </tr> <tr> <td>B</td> <td>C58-GF</td> <td>18</td> <td>WH</td> <td>1661261C1</td> </tr> </tbody> </table>				CAV	CIR	GAUGE	COLOR	TERMINAL	A	C58F	18	BN	1661261C1	B	C58-GF	18	WH	1661261C1
CAV	CIR	GAUGE	COLOR	TERMINAL																		
A	C58F	18	BN	1661261C1																		
B	C58-GF	18	WH	1661261C1																		
CONNECTOR 1661259C1 BODY LOCK 1661263C1																						
CHK	DATE	CHANGE	REV	REFERENCE	DRAWN	NAME																
CNA1	14JAN09	TITLE WAS CIRCUIT	A	61254R	U00K640	CIRCUIT DIAGRAM, PROSTAR, LONESTAR																
		DIAGRAM, PROSTAR			RELEASE NO. 59637L	DATE 06SEP06	PART NO. AE08055906															
						SHEET	002															

Figure 233 Connector Composites (521), (522), (523), (524)

14.5. CONNECTOR COMPOSITES (1002), (1003), P. 3

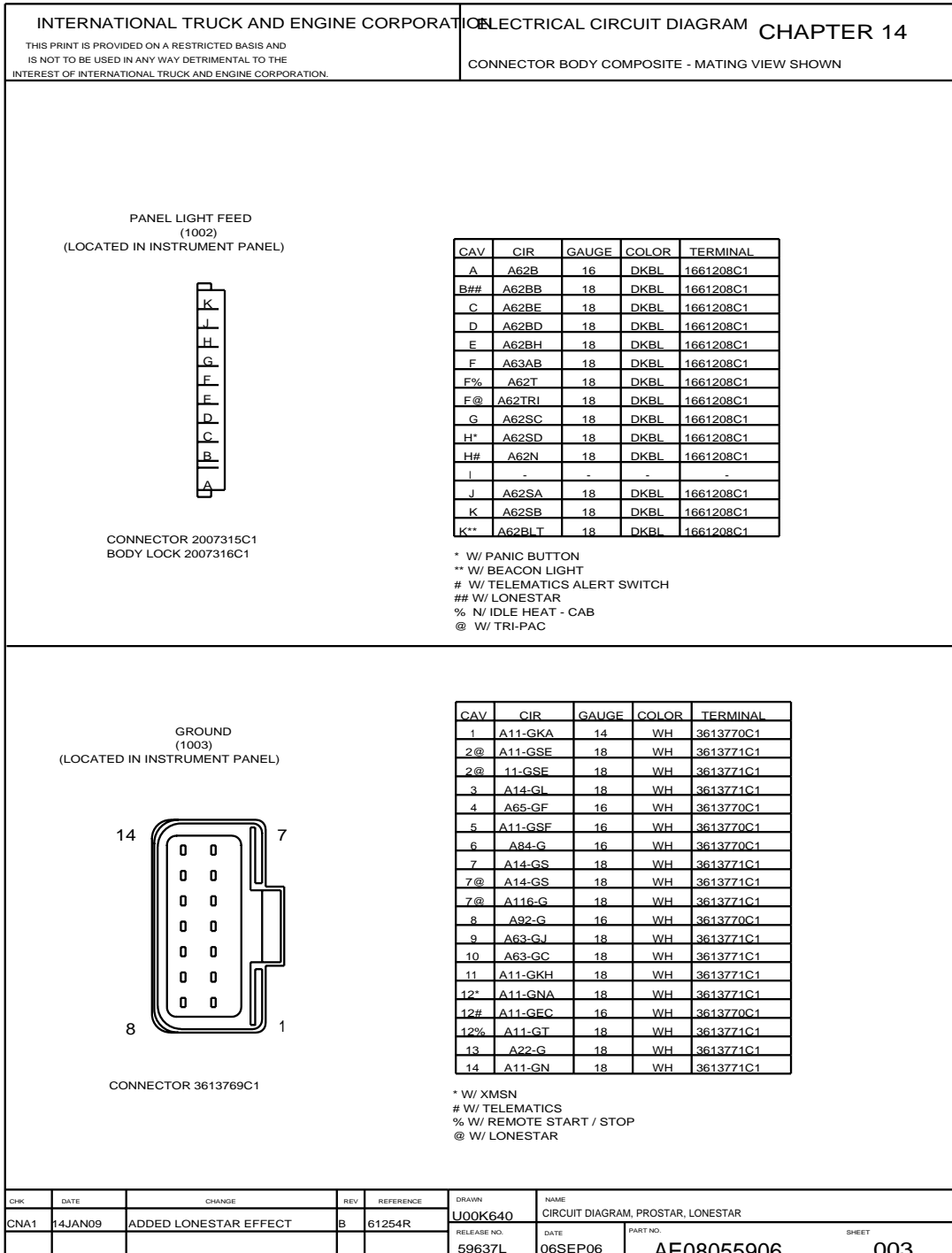


Figure 234 Connector Composites (1002), (1003)

14.6. CONNECTOR COMPOSITES (1006), (1007), (1010), (1015), P. 4

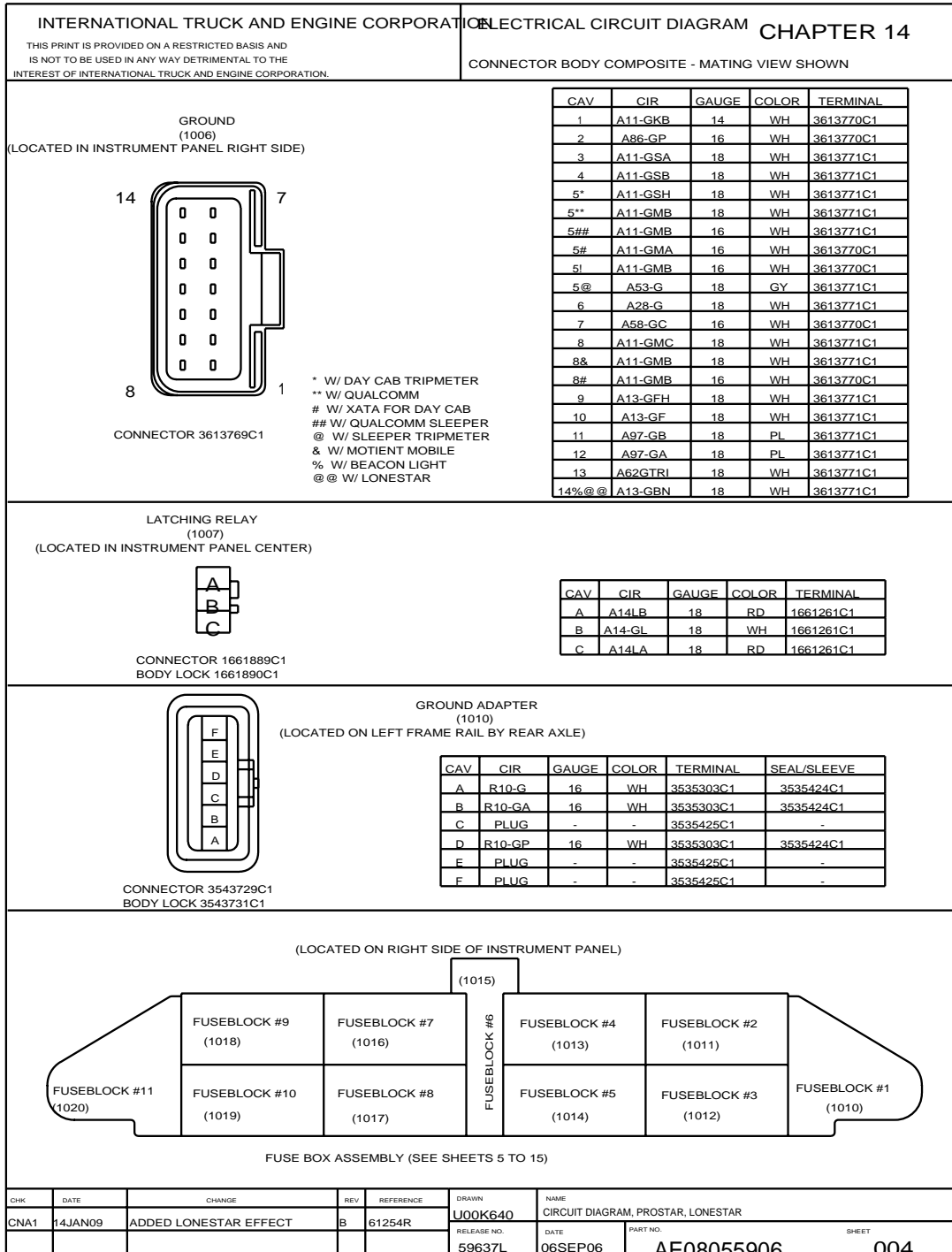


Figure 235 Connector Composites (1006), (1007), (1010), (1015)

14.7. CONNECTOR COMPOSITE (1010), P. 5

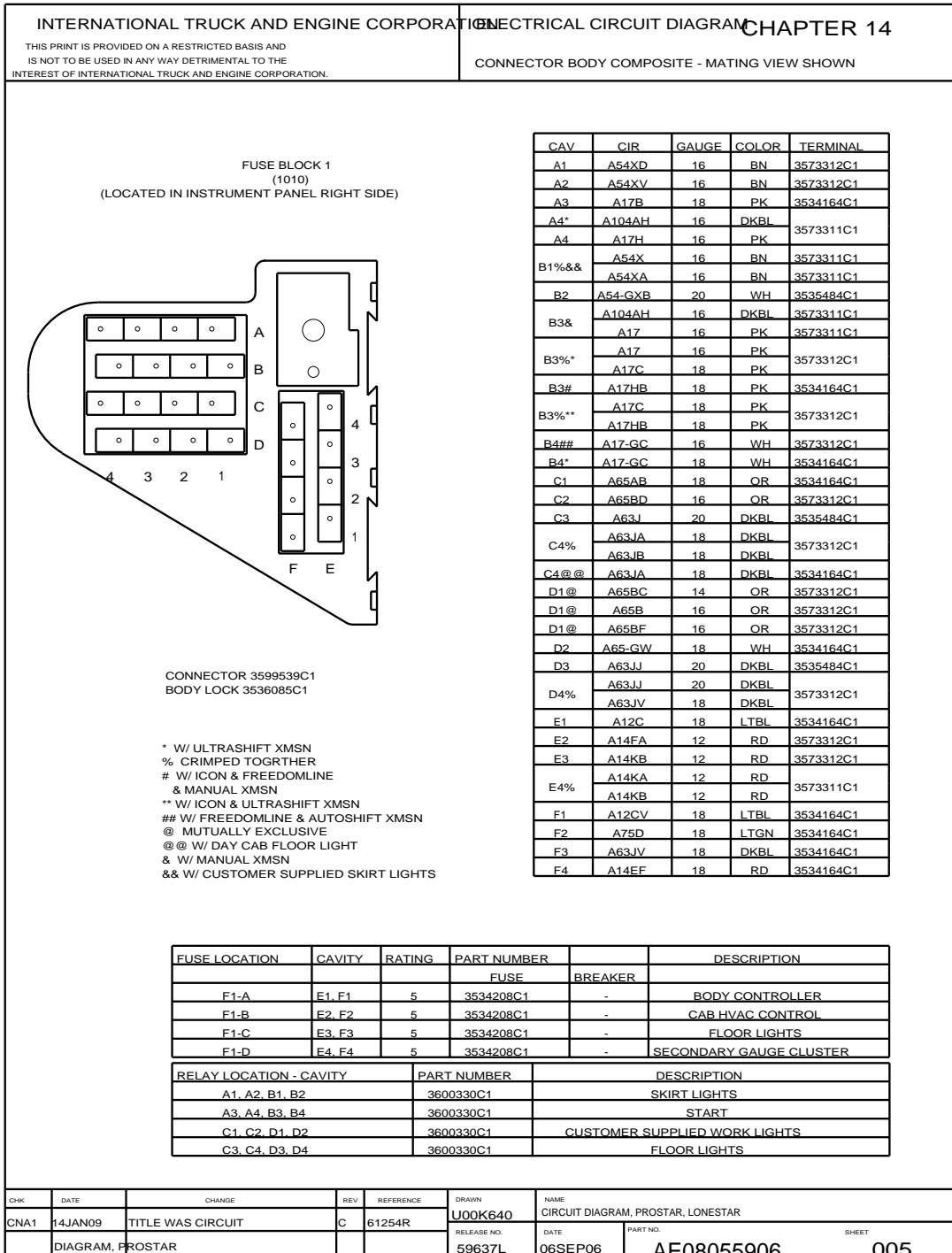


Figure 236 Connector Composite (1010)

14.8. CONNECTOR COMPOSITE (1011), P. 6

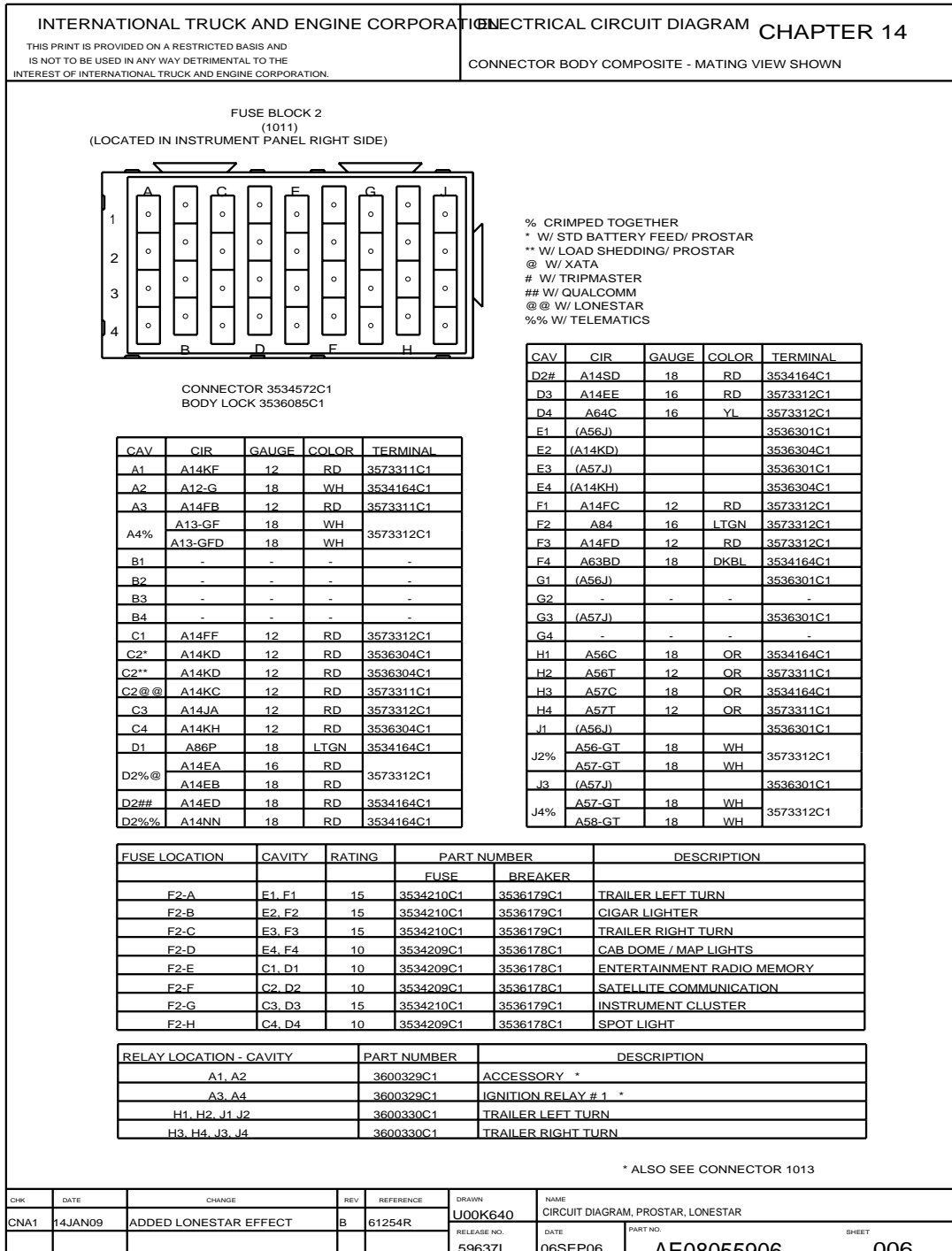


Figure 237 Connector Composite (1011)

14.9. CONNECTOR COMPOSITE (1012), P. 7

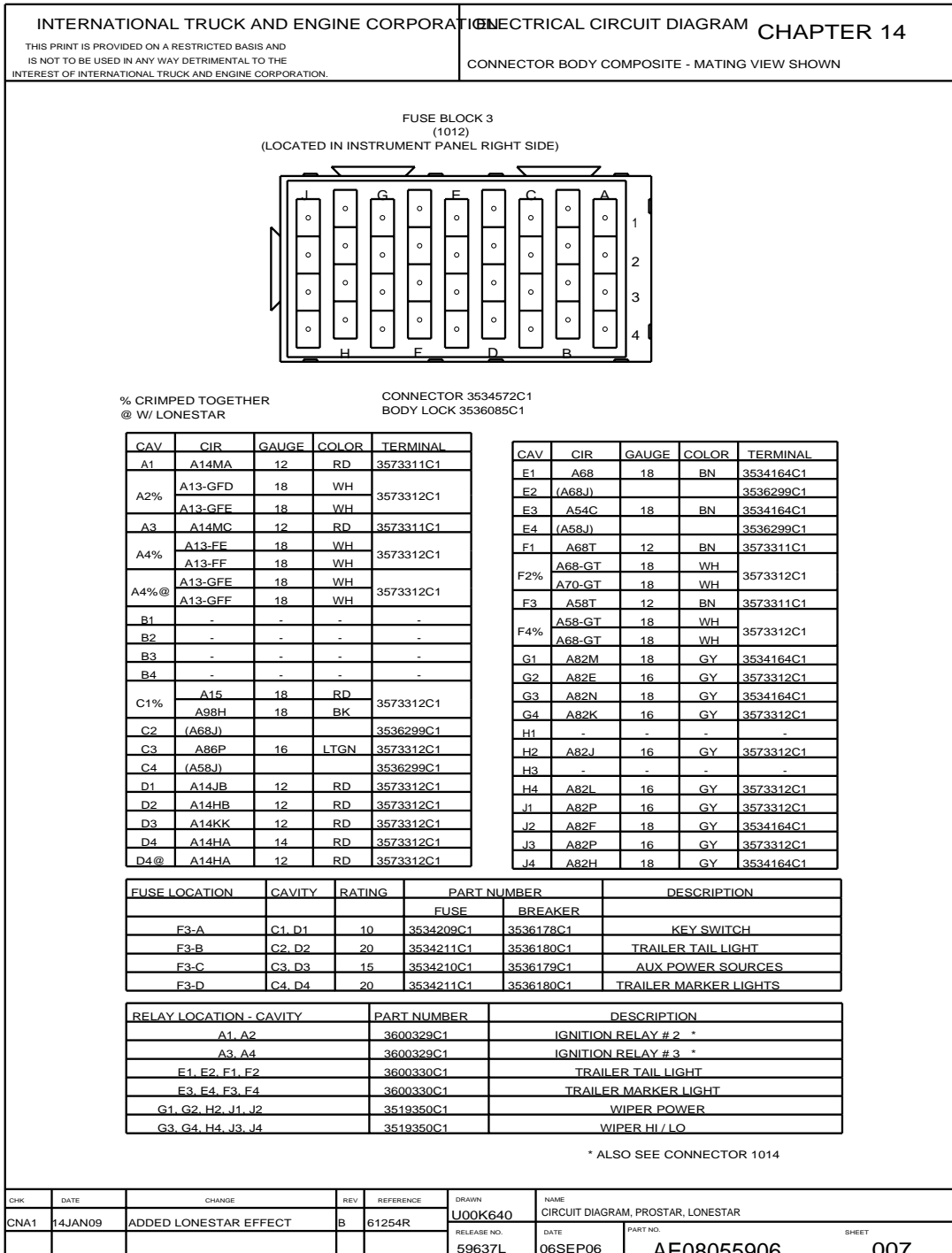


Figure 238 Connector Composite (1012)

14.10. CONNECTOR COMPOSITE (1013), P. 8

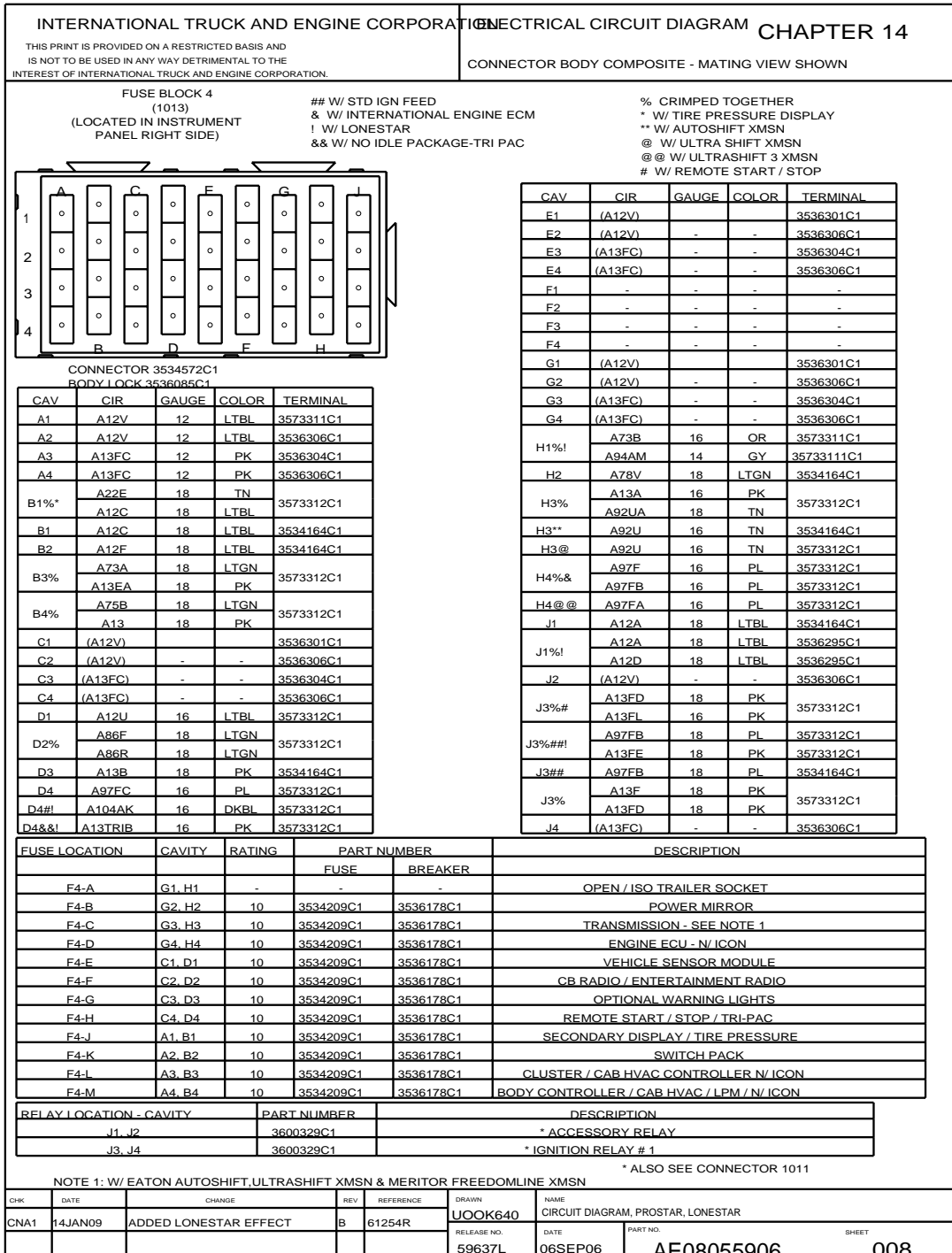


Figure 239 Connector Composite (1013)

14.11. CONNECTOR COMPOSITE (1014), P. 9

INTERNATIONAL TRUCK AND ENGINE CORPORATION ELECTRICAL CIRCUIT DIAGRAM CHAPTER 14  
 THIS PRINT IS PROVIDED ON A RESTRICTED BASIS AND IS NOT TO BE USED IN ANY WAY DETRIMENTAL TO THE INTEREST OF INTERNATIONAL TRUCK AND ENGINE CORPORATION.  
 CONNECTOR BODY COMPOSITE - MATING VIEW SHOWN

FUSE BLOCK 5 (1014)  
(LOCATED IN INSTRUMENT PANEL RIGHT SIDE)

CONNECTOR 3534572C1 BODY LOCK 3536085C1

% CRIMPED TOGETHER \* MUTUALLY EXCLUSIVE  
 @@ W/ ICON # W/ SLEEPER TRIPMETER  
 @ W/ QUALCOMM FOR SLEEPER ## W/ DAYCAB TRIPMETER  
 \*\* W/ SMARTCRUISE ONLY %% W/ LONESTAR  
 (VORAD VS-400) & W/ QUALCOMM FOR DAYCAB  
 && W/ WABCO ONGUARD

CAV	CIR	GAUGE	COLOR	TERMINAL
G1	(A13FB)	-	-	3536304C1
G2	(A13FB)	-	-	3536306C1
G3	(A13FA)	-	-	3536304C1
G4	(A13FA)	-	-	3536306C1
H1	A67A	16	GY	3573312C1
H1**	A67A	16	PK	3573312C1
H1&&	A67CC	16	PK	3573312C1
H2	A88V	18	LTGN	3534164C1
H3	A87C	18	GY	3534164C1
H4	A13EH	18	PK	3534164C1
J1%	A13FD	18	PK	3573312C1
J1@%	A13FE	18	PK	3573312C1
J1@@%	A13FH	18	PK	3573312C1
J2	(A13FB)	-	-	3536306C1
J3%	A13-GFE	18	PK	3573312C1
J3%	A13-GFF	18	PK	3573312C1
J4	(A13FA)	-	-	3536306C1
F4	-	-	-	-

CAV	CIR	GAUGE	COLOR	TERMINAL
A1	A13FB	12	PK	3536304C1
A2	A13FB	12	PK	3536306C1
A3	A13FA	12	PK	3536304C1
A4	A13FA	12	PK	3536306C1
B1%#	A13SD	18	PK	3573312C1
	A70D	18	OR	3573312C1
B1&	A13EE	16	DKBL	3515517C1
B1@	A13FE	18	PK	3534164C1
B1%##	A13FE	18	PK	3573312C1
	A13EF	18	PK	3573312C1
B1##	A70D	18	GY	3573312C1
B1	A13N	18	PK	3515517C1
B2	A39	16	GY	3573312C1
B3%#	A67FA	18	PK	3534164C1
B4*	A71B	16	OR	3573312C1
B4*	A71A	16	OR	3573312C1
B4*	A71A	18	OR	3534164C1
C1	(A13FB)	-	-	3536304C1
C2%#	(A13FB)	-	-	3536306C1
C3	(A13FA)	-	-	3536304C1
C4	(A13FA)	-	-	3536306C1
D1%#	A13BL1	18	PK	3515517C1
D1@%#	A75B	18	LTGN	3534764C1
D1%	A13EA	18	PK	3573312C1
	A73A	18	LTGN	3573312C1
D2%#	A13SE	18	PK	3534164C1
D3	A1A	18	PK	3515517C1
D4	A28V	18	TN	3534164C1
E1	(A13FB)	-	-	3536304C1
E2	(A13FB)	-	-	3536306C1
E3	(A13FA)	-	-	3536304C1
E4	(A13FA)	-	-	3536306C1
F1	-	-	-	-
F2	-	-	-	-
F3	-	-	-	-

FUSE LOCATION	CAVITY	RATING	PART NUMBER		DESCRIPTION
			FUSE	BREAKER	
F5-A	G1, H1	10	3534209C1	3536178C1	COLLISION AVOIDANCE
F5-B	G2, H2	10	3534209C1	3536178C1	PTO
F5-C	G3, H3	10	3534209C1	3536178C1	WINDSHIELD WASHER PUMP
F5-D	G4, H4	10	3534209C1	3536178C1	SECONDARY GAUGE CLUSTER
F5-E	C1, D1	10	3534209C1	3536178C1	CLUSTER / CAB HVAC CONTROLLER W/ ICON
F5-E	C1, D1	10/5	3534209C1	3536178C1	CLUSTER / CAB HVAC CONTROLLER W/ ICON
F5-F	C2, D2	10	3534209C1	3536178C1	CAB HVAC CPM W/ ICON / BEACON N/ICON
F5-F	C2, D2	10	3534209C1	3536178C1	DRIVER DISPLAY
F5-G	C3, D3	-	-	-	A
F5-G	C3, D3	5A	-	-	ALTERNATOR WARNING
F5-G	C3, D3	10A	-	-	5TH WHEEL JAW UNLOCK AND MNTR
F5-G	C3, D3	5A	-	-	BEACON W/ ICON
F5-H	C4, D4	10	3534209C1	3536178C1	COMPASS MODULE
F5-J	A1, B1	10	3534209C1	3536178C1	SATELLITE COMMUNICATION
F5-K	A2, B2	15	3534210C1	3536179C1	AIR DRYER
F5-L	A3, B3	-	-	-	COLLISION AVOIDANCE SIDE
F5-M	A4, B4	10	3534209C1	3536178C1	BACK-UP LIGHTS

RELAY LOCATION - CAVITY	PART NUMBER	DESCRIPTION
J1, J2	3600329C1	IGNITION RELAY # 2 *
J3, J4	3600329C1	IGNITION RELAY # 3 *

CHK	DATE	CHANGE	REV	REFERENCE	DRAWN	NAME
CNA1	07OCT09	W484//ADDED WABCO	D	62556A	U00K640	CIRCUIT DIAGRAM, PROSTAR, LONESTAR
	ONGUARD				59637L	06SEP06 AE08055906 009

\* ALSO SEE CONNECTOR 1012

Figure 240 Connector Composite (1014)

14.12. CONNECTOR COMPOSITE (1015), P. 10

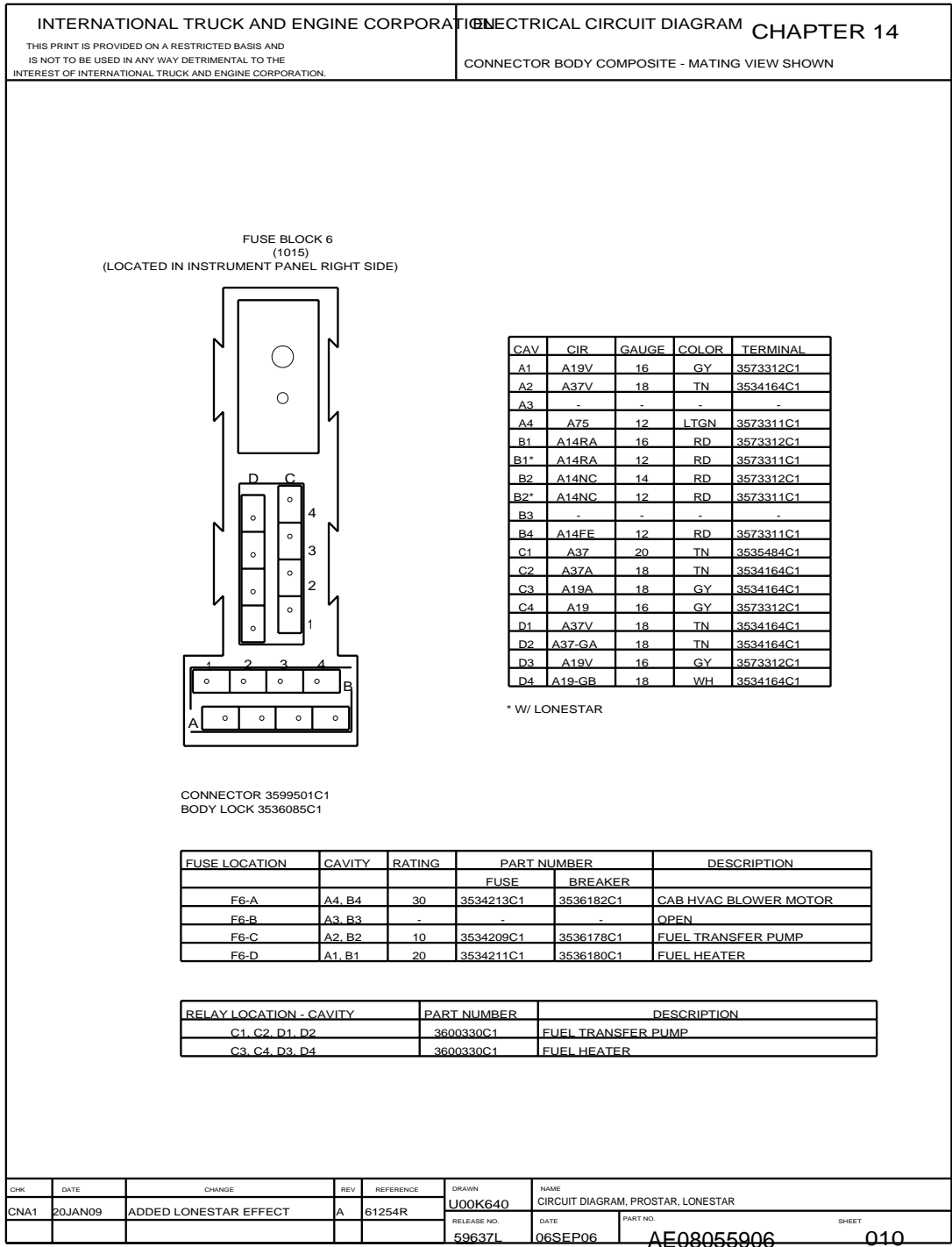


Figure 241 Connector Composite (1015)

14.13. CONNECTOR COMPOSITE (1016), P. 11

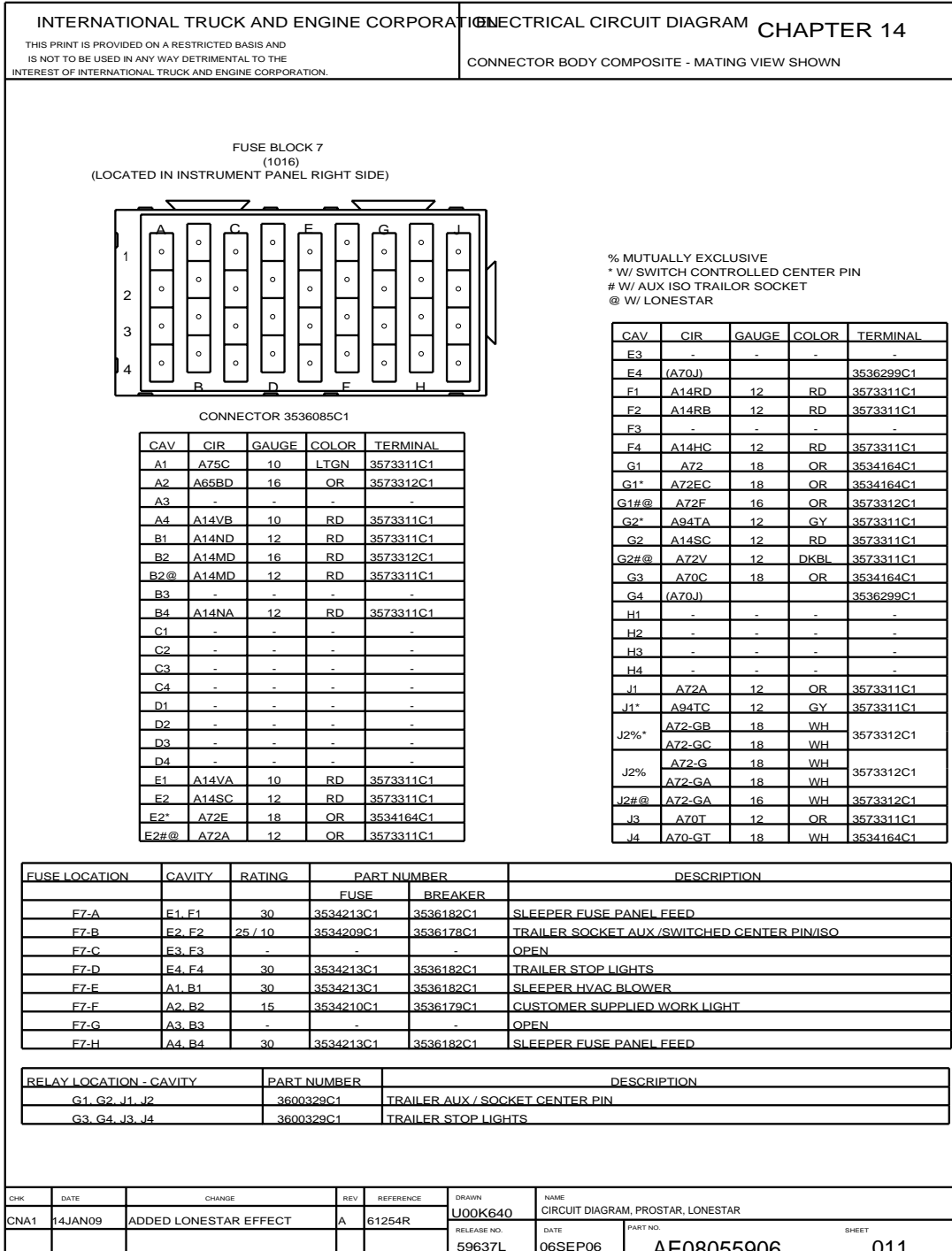


Figure 242 Connector Composite (1016)

14.14. CONNECTOR COMPOSITE (1017), P. 12

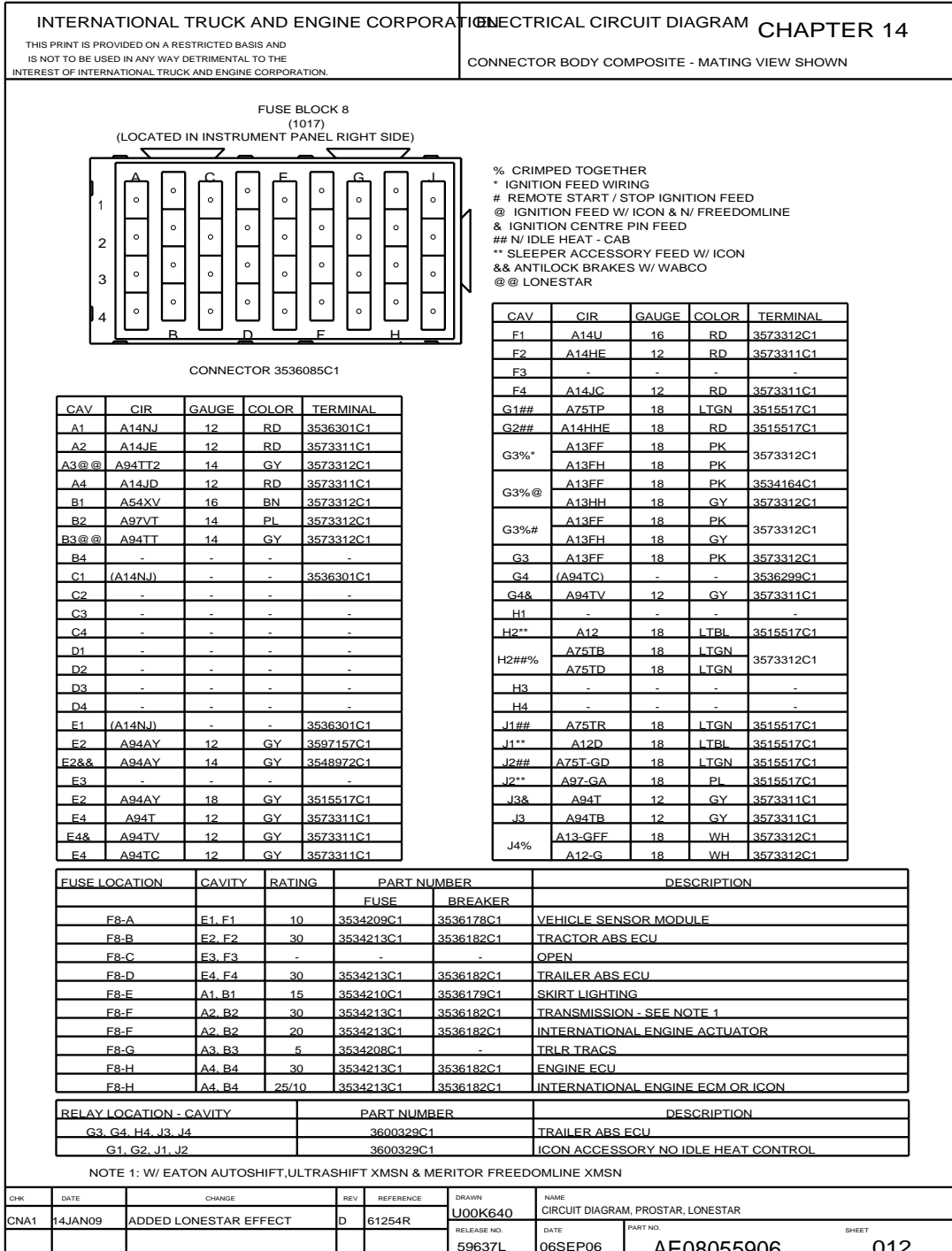


Figure 243 Connector Composite (1017)

14.15. CONNECTOR COMPOSITE (1018), P. 13

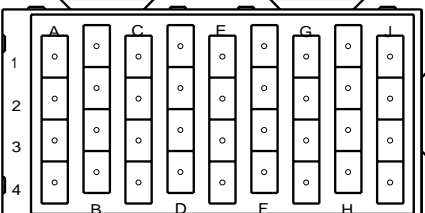
INTERNATIONAL TRUCK AND ENGINE CORPORATION		ELECTRICAL CIRCUIT DIAGRAM		CHAPTER 14																																																																																																																																																																																																																																																																																																													
THIS PRINT IS PROVIDED ON A RESTRICTED BASIS AND IS NOT TO BE USED IN ANY WAY DETRIMENTAL TO THE INTEREST OF INTERNATIONAL TRUCK AND ENGINE CORPORATION.		CONNECTOR BODY COMPOSITE - MATING VIEW SHOWN																																																																																																																																																																																																																																																																																																															
<p style="text-align: center;">FUSE BLOCK 9 (1018) (LOCATED IN INSTRUMENT PANEL RIGHT SIDE)</p>  <p style="text-align: center;">CONNECTOR 3536085C1</p> <table border="1" style="width:100%; border-collapse: collapse; font-size: x-small;"> <thead> <tr> <th>CAV</th><th>CIR</th><th>GAUGE</th><th>COLOR</th><th>TERMINAL</th></tr> </thead> <tbody> <tr><td>A1</td><td>A81C</td><td>12</td><td>LT GN</td><td>3573311C1</td></tr> <tr><td>A2</td><td>-</td><td>-</td><td>-</td><td>-</td></tr> <tr><td>A3</td><td>A97E</td><td>14</td><td>PL</td><td>3573312C1</td></tr> <tr><td>A3@</td><td>A97FZ</td><td>14</td><td>RD</td><td>3573312C1</td></tr> <tr><td>A4</td><td>-</td><td>-</td><td>-</td><td>-</td></tr> <tr><td>B1</td><td>A14NB</td><td>12</td><td>RD</td><td>3573311C1</td></tr> <tr><td>B2</td><td>-</td><td>-</td><td>-</td><td>-</td></tr> <tr><td>B3</td><td>A14KJ</td><td>12</td><td>RD</td><td>3573311C1</td></tr> <tr><td>B4</td><td>-</td><td>-</td><td>-</td><td>-</td></tr> <tr><td>C1</td><td>A81B</td><td>12</td><td>LT GN</td><td>3573311C1</td></tr> <tr><td>C2&amp;</td><td>A13FK</td><td>18</td><td>PK</td><td>3534164C1</td></tr> <tr><td>C2%%</td><td>A14TR1A</td><td>16</td><td>RD</td><td>3515517C1</td></tr> <tr><td>C3</td><td>-</td><td>-</td><td>-</td><td>-</td></tr> <tr><td>C4</td><td>-</td><td>-</td><td>-</td><td>-</td></tr> <tr><td>D1</td><td>A14MB</td><td>12</td><td>RD</td><td>3573311C1</td></tr> <tr><td>D2%*</td><td>A13HA</td><td>18</td><td>PK</td><td>3573312C1</td></tr> <tr><td>D3</td><td>-</td><td>-</td><td>-</td><td>-</td></tr> <tr><td>D4</td><td>-</td><td>-</td><td>-</td><td>-</td></tr> <tr><td>E1</td><td>-</td><td>-</td><td>-</td><td>-</td></tr> <tr><td>E2</td><td>-</td><td>-</td><td>-</td><td>-</td></tr> <tr><td>E3</td><td>-</td><td>-</td><td>-</td><td>-</td></tr> <tr><td>E4</td><td>(A97H)</td><td>-</td><td>-</td><td>3536301C1</td></tr> </tbody> </table>		CAV	CIR	GAUGE	COLOR	TERMINAL	A1	A81C	12	LT GN	3573311C1	A2	-	-	-	-	A3	A97E	14	PL	3573312C1	A3@	A97FZ	14	RD	3573312C1	A4	-	-	-	-	B1	A14NB	12	RD	3573311C1	B2	-	-	-	-	B3	A14KJ	12	RD	3573311C1	B4	-	-	-	-	C1	A81B	12	LT GN	3573311C1	C2&	A13FK	18	PK	3534164C1	C2%%	A14TR1A	16	RD	3515517C1	C3	-	-	-	-	C4	-	-	-	-	D1	A14MB	12	RD	3573311C1	D2%*	A13HA	18	PK	3573312C1	D3	-	-	-	-	D4	-	-	-	-	E1	-	-	-	-	E2	-	-	-	-	E3	-	-	-	-	E4	(A97H)	-	-	3536301C1	<p>% CRIMPED TOGETHER * IDLE REDUCTION # IGNITION FEED WIRING ** N/ IDLE HEAT - CAB ## W/ REMOTE START / STOP @ W/ LONESTAR %% W/ NO IDLE PACKAGE (TRI-PAC)</p> <table border="1" style="width:100%; border-collapse: collapse; font-size: x-small;"> <thead> <tr> <th>CAV</th><th>CIR</th><th>GAUGE</th><th>COLOR</th><th>TERMINAL</th></tr> </thead> <tbody> <tr><td>F1%##</td><td>A104AN</td><td>16</td><td>DKBL</td><td>3573312C1</td></tr> <tr><td></td><td>A104AP</td><td>18</td><td>DKBL</td><td></td></tr> <tr><td>F1**</td><td>A75TL</td><td>18</td><td>LTGN</td><td>3515517C1</td></tr> <tr><td>F2**</td><td>A75TC</td><td>18</td><td>LTGN</td><td>3515517C1</td></tr> <tr><td>F2##</td><td>A104AJ</td><td>16</td><td>DKBL</td><td>3573312C1</td></tr> <tr><td>F3</td><td>-</td><td>-</td><td>-</td><td>-</td></tr> <tr><td>F4</td><td>A14KL</td><td>12</td><td>RD</td><td>3573311C1</td></tr> <tr><td>G1</td><td>A97X</td><td>18</td><td>PL</td><td>3573312C1</td></tr> <tr><td>G1</td><td>A97Z</td><td>18</td><td>PL</td><td>3573312C1</td></tr> <tr><td>G1%##</td><td>A104AL</td><td>16</td><td>DKBL</td><td>3573311C1</td></tr> <tr><td></td><td>A104AK</td><td>16</td><td>DKBL</td><td></td></tr> <tr><td>G1**</td><td>A75TK</td><td>18</td><td>LTGN</td><td>3515517C1</td></tr> <tr><td>G2##</td><td>A104-GA</td><td>18</td><td>WH</td><td>3573312C1</td></tr> <tr><td>G2**</td><td>A75TD</td><td>18</td><td>LTGN</td><td>3515517C1</td></tr> <tr><td>G2%##@</td><td>A104G</td><td>18</td><td>WH</td><td>3573312C1</td></tr> <tr><td></td><td>A104-GA</td><td>18</td><td>WH</td><td></td></tr> <tr><td>G3</td><td>A97HB</td><td>16</td><td>PL</td><td>3573312C1</td></tr> <tr><td>G4</td><td>(A97H)</td><td>-</td><td>-</td><td>3536301C1</td></tr> <tr><td></td><td>A104AP</td><td>18</td><td>DKBL</td><td>3515517C1</td></tr> <tr><td>H1**</td><td>A75TJ</td><td>18</td><td>LTGN</td><td>3515517C1</td></tr> <tr><td>H2</td><td>A13FH</td><td>18</td><td>PK</td><td>3534164C1</td></tr> <tr><td>H2%&amp;@</td><td>A13FH</td><td>18</td><td>PK</td><td>3573312C1</td></tr> <tr><td></td><td>A97Z</td><td>18</td><td>PL</td><td></td></tr> <tr><td>H2##</td><td>A9RB</td><td>18</td><td>GY</td><td>3534164C1</td></tr> <tr><td>H2**</td><td>A75TA</td><td>18</td><td>LTGN</td><td>3534164C1</td></tr> <tr><td>H3</td><td>-</td><td>-</td><td>-</td><td>-</td></tr> <tr><td>H4</td><td>-</td><td>-</td><td>-</td><td>-</td></tr> <tr><td>J1%#</td><td>A13F</td><td>18</td><td>PK</td><td>3573312C1</td></tr> <tr><td></td><td>A13FK</td><td>18</td><td>PK</td><td></td></tr> <tr><td>J1**</td><td>A75TH</td><td>18</td><td>LTGN</td><td>3515517C1</td></tr> <tr><td>J1##</td><td>A104AR</td><td>18</td><td>DKBL</td><td>3515517C1</td></tr> <tr><td>J2</td><td>A13-GFH</td><td>18</td><td>WH</td><td>3534164C1</td></tr> <tr><td>J2##</td><td>A104-GA</td><td>18</td><td>WH</td><td>3534164C1</td></tr> <tr><td>J2**</td><td>A75TB</td><td>18</td><td>LTGN</td><td>3534164C1</td></tr> <tr><td>J3</td><td>A97HA</td><td>14</td><td>PL</td><td>3573312C1</td></tr> <tr><td>J4</td><td>(A97H)</td><td>-</td><td>-</td><td>3536301C1</td></tr> </tbody> </table>				CAV	CIR	GAUGE	COLOR	TERMINAL	F1%##	A104AN	16	DKBL	3573312C1		A104AP	18	DKBL		F1**	A75TL	18	LTGN	3515517C1	F2**	A75TC	18	LTGN	3515517C1	F2##	A104AJ	16	DKBL	3573312C1	F3	-	-	-	-	F4	A14KL	12	RD	3573311C1	G1	A97X	18	PL	3573312C1	G1	A97Z	18	PL	3573312C1	G1%##	A104AL	16	DKBL	3573311C1		A104AK	16	DKBL		G1**	A75TK	18	LTGN	3515517C1	G2##	A104-GA	18	WH	3573312C1	G2**	A75TD	18	LTGN	3515517C1	G2%##@	A104G	18	WH	3573312C1		A104-GA	18	WH		G3	A97HB	16	PL	3573312C1	G4	(A97H)	-	-	3536301C1		A104AP	18	DKBL	3515517C1	H1**	A75TJ	18	LTGN	3515517C1	H2	A13FH	18	PK	3534164C1	H2%&@	A13FH	18	PK	3573312C1		A97Z	18	PL		H2##	A9RB	18	GY	3534164C1	H2**	A75TA	18	LTGN	3534164C1	H3	-	-	-	-	H4	-	-	-	-	J1%#	A13F	18	PK	3573312C1		A13FK	18	PK		J1**	A75TH	18	LTGN	3515517C1	J1##	A104AR	18	DKBL	3515517C1	J2	A13-GFH	18	WH	3534164C1	J2##	A104-GA	18	WH	3534164C1	J2**	A75TB	18	LTGN	3534164C1	J3	A97HA	14	PL	3573312C1	J4	(A97H)	-	-	3536301C1
CAV	CIR	GAUGE	COLOR	TERMINAL																																																																																																																																																																																																																																																																																																													
A1	A81C	12	LT GN	3573311C1																																																																																																																																																																																																																																																																																																													
A2	-	-	-	-																																																																																																																																																																																																																																																																																																													
A3	A97E	14	PL	3573312C1																																																																																																																																																																																																																																																																																																													
A3@	A97FZ	14	RD	3573312C1																																																																																																																																																																																																																																																																																																													
A4	-	-	-	-																																																																																																																																																																																																																																																																																																													
B1	A14NB	12	RD	3573311C1																																																																																																																																																																																																																																																																																																													
B2	-	-	-	-																																																																																																																																																																																																																																																																																																													
B3	A14KJ	12	RD	3573311C1																																																																																																																																																																																																																																																																																																													
B4	-	-	-	-																																																																																																																																																																																																																																																																																																													
C1	A81B	12	LT GN	3573311C1																																																																																																																																																																																																																																																																																																													
C2&	A13FK	18	PK	3534164C1																																																																																																																																																																																																																																																																																																													
C2%%	A14TR1A	16	RD	3515517C1																																																																																																																																																																																																																																																																																																													
C3	-	-	-	-																																																																																																																																																																																																																																																																																																													
C4	-	-	-	-																																																																																																																																																																																																																																																																																																													
D1	A14MB	12	RD	3573311C1																																																																																																																																																																																																																																																																																																													
D2%*	A13HA	18	PK	3573312C1																																																																																																																																																																																																																																																																																																													
D3	-	-	-	-																																																																																																																																																																																																																																																																																																													
D4	-	-	-	-																																																																																																																																																																																																																																																																																																													
E1	-	-	-	-																																																																																																																																																																																																																																																																																																													
E2	-	-	-	-																																																																																																																																																																																																																																																																																																													
E3	-	-	-	-																																																																																																																																																																																																																																																																																																													
E4	(A97H)	-	-	3536301C1																																																																																																																																																																																																																																																																																																													
CAV	CIR	GAUGE	COLOR	TERMINAL																																																																																																																																																																																																																																																																																																													
F1%##	A104AN	16	DKBL	3573312C1																																																																																																																																																																																																																																																																																																													
	A104AP	18	DKBL																																																																																																																																																																																																																																																																																																														
F1**	A75TL	18	LTGN	3515517C1																																																																																																																																																																																																																																																																																																													
F2**	A75TC	18	LTGN	3515517C1																																																																																																																																																																																																																																																																																																													
F2##	A104AJ	16	DKBL	3573312C1																																																																																																																																																																																																																																																																																																													
F3	-	-	-	-																																																																																																																																																																																																																																																																																																													
F4	A14KL	12	RD	3573311C1																																																																																																																																																																																																																																																																																																													
G1	A97X	18	PL	3573312C1																																																																																																																																																																																																																																																																																																													
G1	A97Z	18	PL	3573312C1																																																																																																																																																																																																																																																																																																													
G1%##	A104AL	16	DKBL	3573311C1																																																																																																																																																																																																																																																																																																													
	A104AK	16	DKBL																																																																																																																																																																																																																																																																																																														
G1**	A75TK	18	LTGN	3515517C1																																																																																																																																																																																																																																																																																																													
G2##	A104-GA	18	WH	3573312C1																																																																																																																																																																																																																																																																																																													
G2**	A75TD	18	LTGN	3515517C1																																																																																																																																																																																																																																																																																																													
G2%##@	A104G	18	WH	3573312C1																																																																																																																																																																																																																																																																																																													
	A104-GA	18	WH																																																																																																																																																																																																																																																																																																														
G3	A97HB	16	PL	3573312C1																																																																																																																																																																																																																																																																																																													
G4	(A97H)	-	-	3536301C1																																																																																																																																																																																																																																																																																																													
	A104AP	18	DKBL	3515517C1																																																																																																																																																																																																																																																																																																													
H1**	A75TJ	18	LTGN	3515517C1																																																																																																																																																																																																																																																																																																													
H2	A13FH	18	PK	3534164C1																																																																																																																																																																																																																																																																																																													
H2%&@	A13FH	18	PK	3573312C1																																																																																																																																																																																																																																																																																																													
	A97Z	18	PL																																																																																																																																																																																																																																																																																																														
H2##	A9RB	18	GY	3534164C1																																																																																																																																																																																																																																																																																																													
H2**	A75TA	18	LTGN	3534164C1																																																																																																																																																																																																																																																																																																													
H3	-	-	-	-																																																																																																																																																																																																																																																																																																													
H4	-	-	-	-																																																																																																																																																																																																																																																																																																													
J1%#	A13F	18	PK	3573312C1																																																																																																																																																																																																																																																																																																													
	A13FK	18	PK																																																																																																																																																																																																																																																																																																														
J1**	A75TH	18	LTGN	3515517C1																																																																																																																																																																																																																																																																																																													
J1##	A104AR	18	DKBL	3515517C1																																																																																																																																																																																																																																																																																																													
J2	A13-GFH	18	WH	3534164C1																																																																																																																																																																																																																																																																																																													
J2##	A104-GA	18	WH	3534164C1																																																																																																																																																																																																																																																																																																													
J2**	A75TB	18	LTGN	3534164C1																																																																																																																																																																																																																																																																																																													
J3	A97HA	14	PL	3573312C1																																																																																																																																																																																																																																																																																																													
J4	(A97H)	-	-	3536301C1																																																																																																																																																																																																																																																																																																													
<table border="1" style="width:100%; border-collapse: collapse; font-size: x-small;"> <thead> <tr> <th>FUSE LOCATION</th><th>CAVITY</th><th>RATING</th><th>PART NUMBER</th><th>FUSE</th><th>CIR BREAKER</th><th>DESCRIPTION</th></tr> </thead> <tbody> <tr><td>F9-A</td><td>C1, D1</td><td>30</td><td>3534213C1</td><td>3534213C1</td><td>3536182C1</td><td>POWER WINDOW / DOOR - DRIVER</td></tr> <tr><td>F9-B</td><td>C2, D2</td><td>7.5/3</td><td>3546109C1</td><td>3546109C1</td><td>3536177C1</td><td>ICON OR TRI-PAC</td></tr> <tr><td>F9-C</td><td>F3, F3</td><td>10</td><td>3534209C1</td><td>3534209C1</td><td>3536178C1</td><td>INTERNATIONAL ENGINE AFTER TREATMENT</td></tr> <tr><td>F9-D</td><td>E4, F4</td><td>20</td><td>3534211C1</td><td>3534211C1</td><td>3536180C1</td><td>INTERNATIONAL ENGINE ECM RELAY</td></tr> <tr><td>F9-E</td><td>A1, B1</td><td>30</td><td>3534213C1</td><td>3534213C1</td><td>3536182C1</td><td>POWER WINDOW / DOOR PASSENGER</td></tr> <tr><td>F9-F</td><td>A2, B2</td><td>-</td><td>-</td><td>-</td><td>-</td><td>OPEN</td></tr> <tr><td>F9-G</td><td>A3, B3</td><td>20</td><td>3534211C1</td><td>3534211C1</td><td>3536180C1</td><td>INTERNATIONAL ENGINE</td></tr> <tr><td>F9-H</td><td>A4, B4</td><td>-</td><td>-</td><td>-</td><td>-</td><td>OPEN</td></tr> </tbody> </table>						FUSE LOCATION	CAVITY	RATING	PART NUMBER	FUSE	CIR BREAKER	DESCRIPTION	F9-A	C1, D1	30	3534213C1	3534213C1	3536182C1	POWER WINDOW / DOOR - DRIVER	F9-B	C2, D2	7.5/3	3546109C1	3546109C1	3536177C1	ICON OR TRI-PAC	F9-C	F3, F3	10	3534209C1	3534209C1	3536178C1	INTERNATIONAL ENGINE AFTER TREATMENT	F9-D	E4, F4	20	3534211C1	3534211C1	3536180C1	INTERNATIONAL ENGINE ECM RELAY	F9-E	A1, B1	30	3534213C1	3534213C1	3536182C1	POWER WINDOW / DOOR PASSENGER	F9-F	A2, B2	-	-	-	-	OPEN	F9-G	A3, B3	20	3534211C1	3534211C1	3536180C1	INTERNATIONAL ENGINE	F9-H	A4, B4	-	-	-	-	OPEN																																																																																																																																																																																																																																													
FUSE LOCATION	CAVITY	RATING	PART NUMBER	FUSE	CIR BREAKER	DESCRIPTION																																																																																																																																																																																																																																																																																																											
F9-A	C1, D1	30	3534213C1	3534213C1	3536182C1	POWER WINDOW / DOOR - DRIVER																																																																																																																																																																																																																																																																																																											
F9-B	C2, D2	7.5/3	3546109C1	3546109C1	3536177C1	ICON OR TRI-PAC																																																																																																																																																																																																																																																																																																											
F9-C	F3, F3	10	3534209C1	3534209C1	3536178C1	INTERNATIONAL ENGINE AFTER TREATMENT																																																																																																																																																																																																																																																																																																											
F9-D	E4, F4	20	3534211C1	3534211C1	3536180C1	INTERNATIONAL ENGINE ECM RELAY																																																																																																																																																																																																																																																																																																											
F9-E	A1, B1	30	3534213C1	3534213C1	3536182C1	POWER WINDOW / DOOR PASSENGER																																																																																																																																																																																																																																																																																																											
F9-F	A2, B2	-	-	-	-	OPEN																																																																																																																																																																																																																																																																																																											
F9-G	A3, B3	20	3534211C1	3534211C1	3536180C1	INTERNATIONAL ENGINE																																																																																																																																																																																																																																																																																																											
F9-H	A4, B4	-	-	-	-	OPEN																																																																																																																																																																																																																																																																																																											
<table border="1" style="width:100%; border-collapse: collapse; font-size: x-small;"> <thead> <tr> <th>RELAY LOCATION - CAVITY</th><th>PART NUMBER</th><th>DESCRIPTION</th></tr> </thead> <tbody> <tr><td>H1, H2, J1, J2</td><td>3600330C1</td><td>SEE NOTE 1</td></tr> <tr><td>G1, G2, F1, F2</td><td>3600330C1</td><td>SEE NOTE 2</td></tr> <tr><td>G3, G4, H4, J3, J4</td><td>3600329C1</td><td>INTERNATIONAL ENGINE</td></tr> </tbody> </table>						RELAY LOCATION - CAVITY	PART NUMBER	DESCRIPTION	H1, H2, J1, J2	3600330C1	SEE NOTE 1	G1, G2, F1, F2	3600330C1	SEE NOTE 2	G3, G4, H4, J3, J4	3600329C1	INTERNATIONAL ENGINE																																																																																																																																																																																																																																																																																																
RELAY LOCATION - CAVITY	PART NUMBER	DESCRIPTION																																																																																																																																																																																																																																																																																																															
H1, H2, J1, J2	3600330C1	SEE NOTE 1																																																																																																																																																																																																																																																																																																															
G1, G2, F1, F2	3600330C1	SEE NOTE 2																																																																																																																																																																																																																																																																																																															
G3, G4, H4, J3, J4	3600329C1	INTERNATIONAL ENGINE																																																																																																																																																																																																																																																																																																															
<p>NOTE 1: REMOTE START / STOP RELAY # 1 / NO IDLE HEAT - VALVE # 1A RELAY NOTE 2: REMOTE START / STOP RELAY # 2 / NO IDLE HEAT - VALVE # 1B RELAY</p>																																																																																																																																																																																																																																																																																																																	
<table border="1" style="width:100%; border-collapse: collapse; font-size: x-small;"> <thead> <tr> <th>CHK</th><th>DATE</th><th>CHANGE</th><th>REV</th><th>REFERENCE</th><th>DRAWN</th><th>NAME</th></tr> </thead> <tbody> <tr> <td>CNA1</td><td>14JAN09</td><td>ADDED LONESTAR EFFECT</td><td>C</td><td>61254R</td><td>U00K640</td><td>CIRCUIT DIAGRAM, PROSTAR, LONESTAR</td></tr> <tr> <td></td><td></td><td></td><td></td><td></td><td>RELEASE NO. 59637L</td><td>DATE 06SEP06 PART NO. AE08055906 SHEET 013</td></tr> </tbody> </table>						CHK	DATE	CHANGE	REV	REFERENCE	DRAWN	NAME	CNA1	14JAN09	ADDED LONESTAR EFFECT	C	61254R	U00K640	CIRCUIT DIAGRAM, PROSTAR, LONESTAR						RELEASE NO. 59637L	DATE 06SEP06 PART NO. AE08055906 SHEET 013																																																																																																																																																																																																																																																																																							
CHK	DATE	CHANGE	REV	REFERENCE	DRAWN	NAME																																																																																																																																																																																																																																																																																																											
CNA1	14JAN09	ADDED LONESTAR EFFECT	C	61254R	U00K640	CIRCUIT DIAGRAM, PROSTAR, LONESTAR																																																																																																																																																																																																																																																																																																											
					RELEASE NO. 59637L	DATE 06SEP06 PART NO. AE08055906 SHEET 013																																																																																																																																																																																																																																																																																																											

Figure 244 Connector Composite (1018)

14.16. CONNECTOR COMPOSITE (1019), P. 14

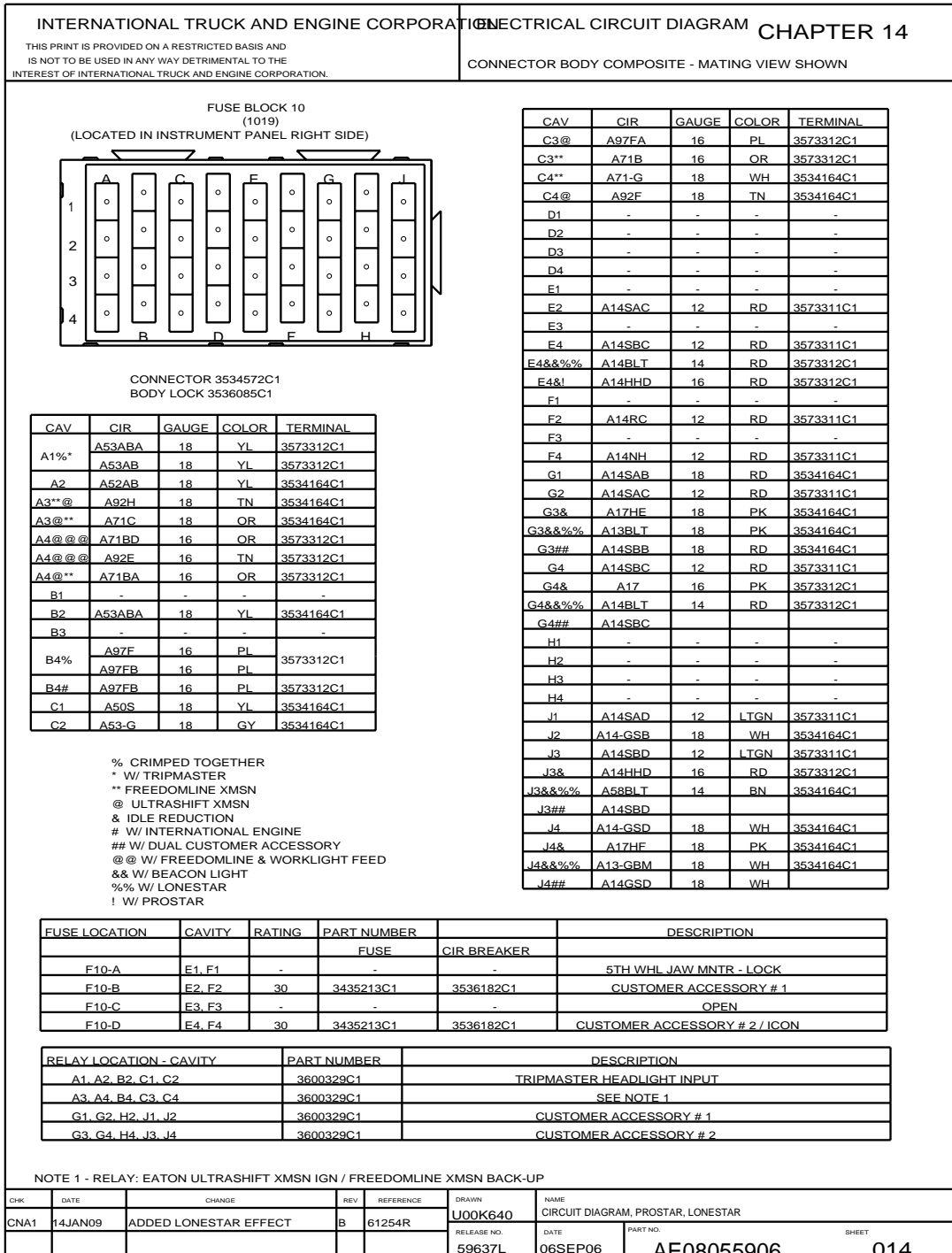


Figure 245 Connector Composite (1019)

14.17. CONNECTOR COMPOSITE (1020), P. 15

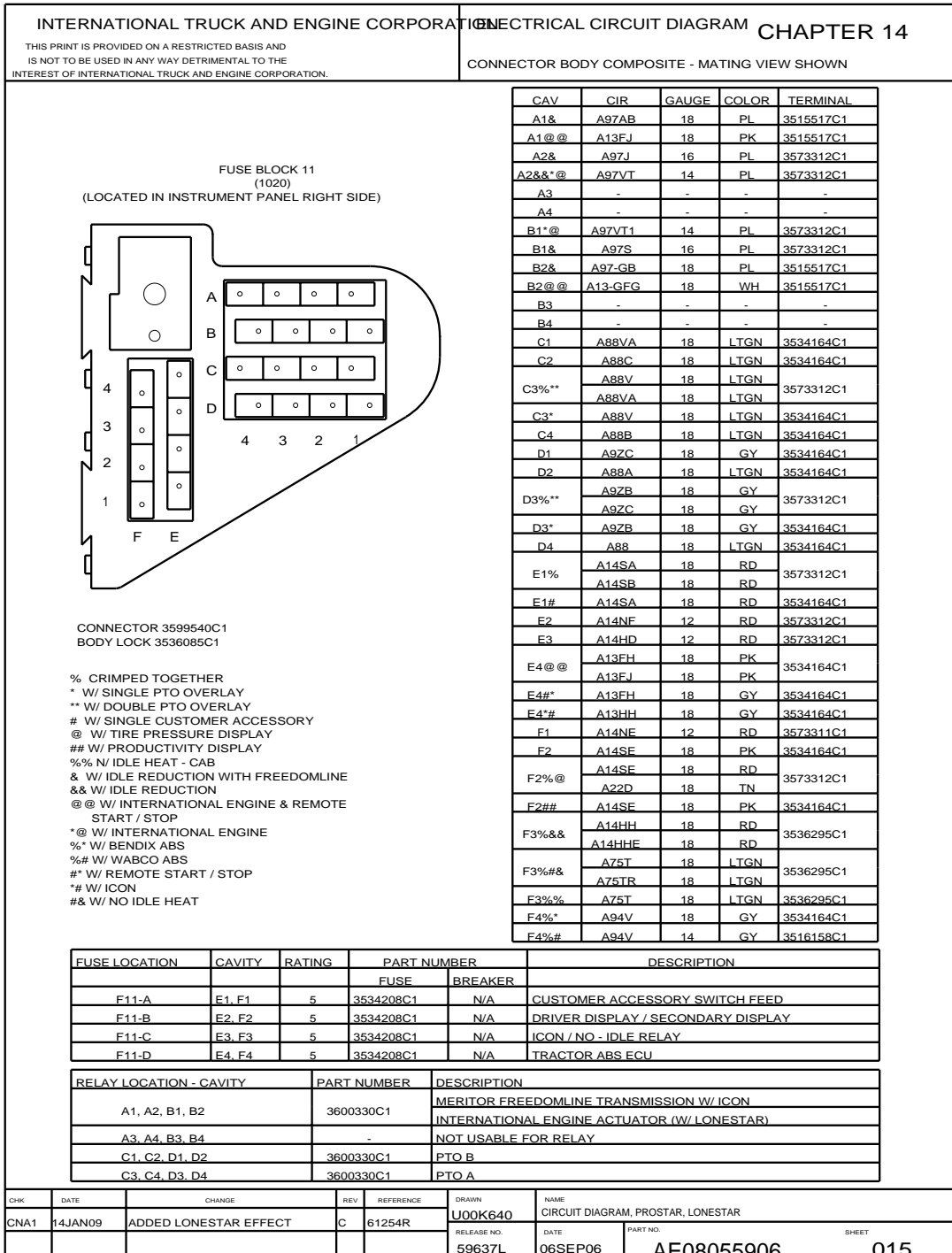


Figure 246 Connector Composite (1020)

14.18. CONNECTOR COMPOSITES (1023), (1024), P. 16

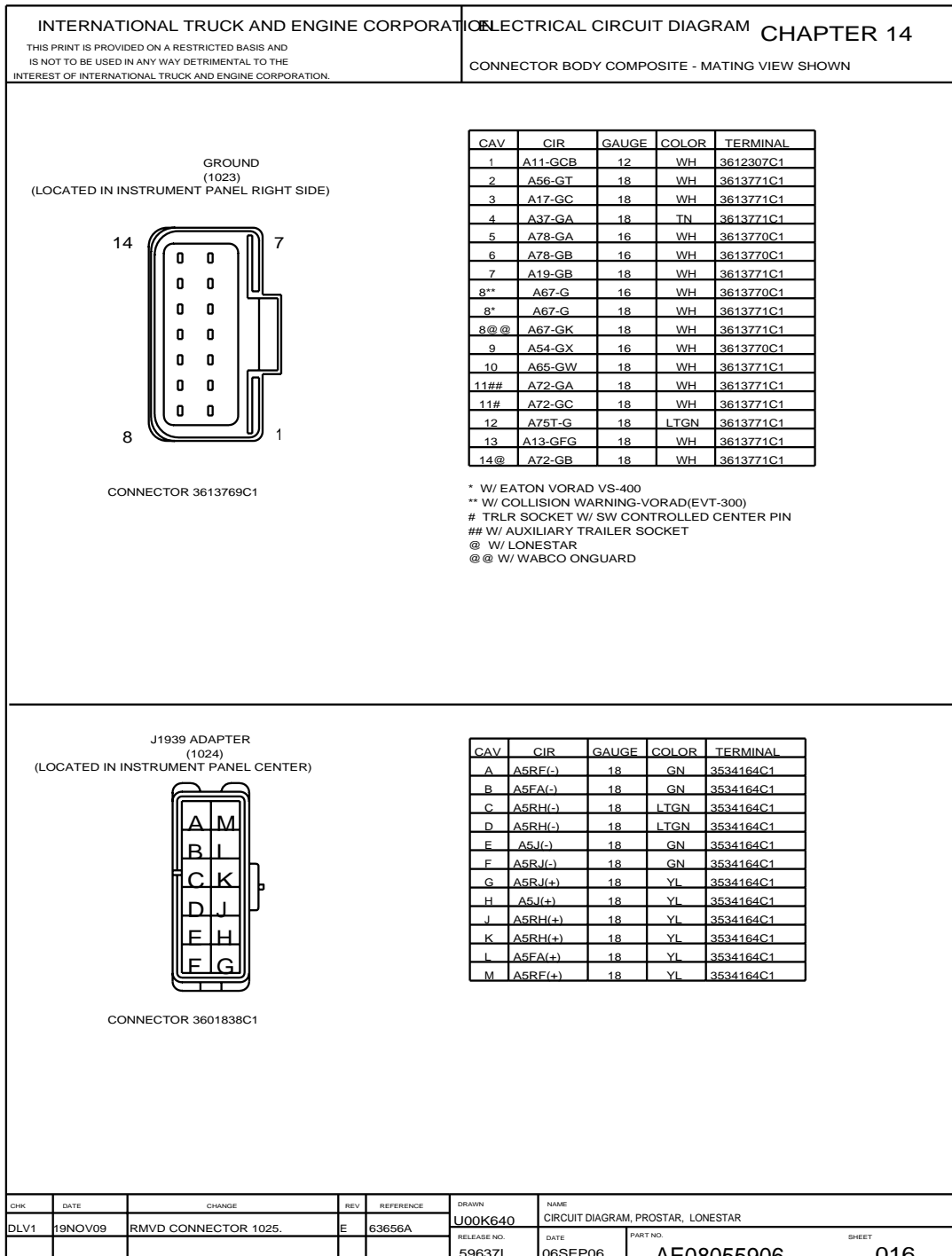


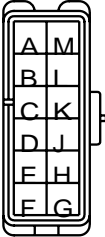
Figure 247 Connector Composites (1023), (1024)

14.19. CONNECTOR COMPOSITES (1025), (1026), P. 16A

INTERNATIONAL TRUCK AND ENGINE CORPORATION		ELECTRICAL CIRCUIT DIAGRAM		CHAPTER 14	
THIS PRINT IS PROVIDED ON A RESTRICTED BASIS AND IS NOT TO BE USED IN ANY WAY DETRIMENTAL TO THE INTEREST OF INTERNATIONAL TRUCK AND ENGINE CORPORATION.		CONNECTOR BODY COMPOSITE - MATING VIEW SHOWN			

J1939 ADAPTER  
(1025)  
(LOCATED IN INSTRUMENT PANEL CENTER)



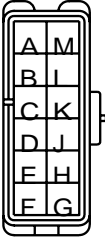
CONNECTOR 3601838C1

CAV	CIR	GAUGE	COLOR	TERMINAL
A	A5RD(-)	18	GN	3534164C1
B	A5HA(-)	18	GN	3534164C1
B*	A5HA(-)	18	GN	3534164C1
C	A5RE(-)	18	LTGN	3534164C1
D	A5RE(-)	18	LTGN	3534164C1
E	A5K(-)	18	GN	3534164C1
E	A5FD(-)	18	GN	3534164C1
F	A5RF(-)	18	GN	3534164C1
G	A5RF(+)	18	YL	3534164C1
H	A5K(+)	18	YL	3534164C1
H	A5FD(+)	18	YL	3534164C1
J	A5RE(+)	18	YL	3534164C1
K	A5RE(+)	18	YL	3534164C1
L	A5HA(+)	18	YL	3534164C1
L*	A5HA(+)	18	YL	3534164C1
M	A5RD(+)	18	YL	3534164C1

\* W/ WABCO ONGUARD

J1939 ADAPTER  
(1026)  
(LOCATED IN INSTRUMENT PANEL CENTER)



CONNECTOR 3601838C1

CAV	CIR	GAUGE	COLOR	TERMINAL
A	A5RB(-)	18	GN	3534164C1
A*	A5R(-)	18	GN	3534164C1
B	A5P(-)	18	GN	3534164C1
C	A5RC(-)	18	LTGN	3534164C1
D	A5RC(-)	18	LTGN	3534164C1
E	A5L(-)	18	GN	3534164C1
F	A5RD(-)	18	GN	3534164C1
G	A5RD(+)	18	YL	3534164C1
H	A5L(+)	18	YL	3534164C1
J	A5RC(+)	18	YL	3534164C1
K	A5RC(+)	18	YL	3534164C1
L	A5P(+)	18	YL	3534164C1
M	A5RB(+)	18	YL	3534164C1
M*	A5R(+)	18	YL	3534164C1

\* W/ ALL OPTIONS & N/ABS OR COMPASS


CHK	DATE	CHANGE	REV	REFERENCE	DRAWN	NAME
DLV1	19NOV09	INITIAL RELEASE.	A	63656A	U00SLK3	CIRCUIT DIAGRAM, PROSTAR, LONESTAR
					RELEASE NO.	DATE
					63656A	19OCT09
						PART NO.
						AE08055906
						SHEET
						16A

Figure 248 Connector Composites (1025), (1026)

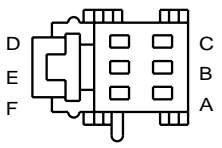
14.20. CONNECTOR COMPOSITES (1100M), (1101M), (1110M), P. 17

<p>INTERNATIONAL TRUCK AND ENGINE CORPORATION</p> <p>THIS PRINT IS PROVIDED ON A RESTRICTED BASIS AND IS NOT TO BE USED IN ANY WAY DETRIMENTAL TO THE INTEREST OF INTERNATIONAL TRUCK AND ENGINE CORPORATION.</p>	<p>ELECTRICAL CIRCUIT DIAGRAM CHAPTER 14</p> <p>CONNECTOR BODY COMPOSITE - MATING VIEW SHOWN</p>
---	--

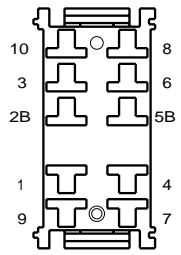
  

<p>KEY SWITCH CONNECTOR (1100M) (LOCATED IN INSTRUMENT PANEL)</p>  <p>CONNECTOR 3546518C1 BODY LOCK 3546519C1</p>	<table border="1" style="width:100%; border-collapse: collapse;"> <thead> <tr> <th>CAV</th> <th>CIR</th> <th>GAUGE</th> <th>COLOR</th> <th>TERMINAL</th> </tr> </thead> <tbody> <tr><td>A</td><td>A15</td><td>18</td><td>RD</td><td>1661208C1</td></tr> <tr><td>B*</td><td>A17H</td><td>16</td><td>PK</td><td>1661208C1</td></tr> <tr><td>B#</td><td>A17HA</td><td>16</td><td>PK</td><td>1661208C1</td></tr> <tr><td>C</td><td>A12</td><td>18</td><td>LTBL</td><td>1661208C1</td></tr> <tr><td>D</td><td>A13F</td><td>18</td><td>PK</td><td>1661208C1</td></tr> <tr><td>D&amp;@</td><td>A13F</td><td>16</td><td>PK</td><td>1661208C1</td></tr> </tbody> </table> <p>* W/ FREEDOM LINE XMSN # W/ MANUAL XMSN &amp; W/ REMOTE START-STOP @ W/ LONESTAR</p>	CAV	CIR	GAUGE	COLOR	TERMINAL	A	A15	18	RD	1661208C1	B*	A17H	16	PK	1661208C1	B#	A17HA	16	PK	1661208C1	C	A12	18	LTBL	1661208C1	D	A13F	18	PK	1661208C1	D&@	A13F	16	PK	1661208C1
CAV	CIR	GAUGE	COLOR	TERMINAL																																
A	A15	18	RD	1661208C1																																
B*	A17H	16	PK	1661208C1																																
B#	A17HA	16	PK	1661208C1																																
C	A12	18	LTBL	1661208C1																																
D	A13F	18	PK	1661208C1																																
D&@	A13F	16	PK	1661208C1																																

<p>SWITCH PACK CONNECTOR (1101M) (LOCATED IN INSTRUMENT PANEL - CENTER)</p>  <p>CONNECTOR 2031871C1 BODY LOCK 2031873C1</p>	<table border="1" style="width:100%; border-collapse: collapse;"> <thead> <tr> <th>CAV</th> <th>CIR</th> <th>GAUGE</th> <th>COLOR</th> <th>TERMINAL</th> </tr> </thead> <tbody> <tr><td>A</td><td>A11-GKD</td><td>18</td><td>WH</td><td>1661261C1</td></tr> <tr><td>B</td><td>A12F</td><td>18</td><td>LTBL</td><td>1661261C1</td></tr> <tr><td>C</td><td>A62DB</td><td>18</td><td>DKBL</td><td>1661261C1</td></tr> <tr><td>D*</td><td>A3AA(+)</td><td>20</td><td>DKBL</td><td>3544254C1</td></tr> <tr><td>D</td><td>A3A(+)</td><td>18</td><td>DKBL</td><td>1661261C1</td></tr> <tr><td>E*</td><td>A3AA(-)</td><td>20</td><td>GY</td><td>3544254C1</td></tr> <tr><td>E</td><td>A3A(-)</td><td>18</td><td>GY</td><td>1661261C1</td></tr> <tr><td>F</td><td>-</td><td>-</td><td>-</td><td>-</td></tr> </tbody> </table> <p>* W/ POWER DOOR LOCK &amp; WINDOWS</p>	CAV	CIR	GAUGE	COLOR	TERMINAL	A	A11-GKD	18	WH	1661261C1	B	A12F	18	LTBL	1661261C1	C	A62DB	18	DKBL	1661261C1	D*	A3AA(+)	20	DKBL	3544254C1	D	A3A(+)	18	DKBL	1661261C1	E*	A3AA(-)	20	GY	3544254C1	E	A3A(-)	18	GY	1661261C1	F	-	-	-	-
CAV	CIR	GAUGE	COLOR	TERMINAL																																										
A	A11-GKD	18	WH	1661261C1																																										
B	A12F	18	LTBL	1661261C1																																										
C	A62DB	18	DKBL	1661261C1																																										
D*	A3AA(+)	20	DKBL	3544254C1																																										
D	A3A(+)	18	DKBL	1661261C1																																										
E*	A3AA(-)	20	GY	3544254C1																																										
E	A3A(-)	18	GY	1661261C1																																										
F	-	-	-	-																																										

<p>AUX TRAILER SOCKET SWITCH CONNECTOR (1110M) (LOCATED IN INSTRUMENT PANEL CENTER)</p>  <p>CONNECTOR 3520850C1</p> <p>* TRAILER SOCKET W/ SWITCH CONTROLLED CENTER PIN % CRIMPED TOGETHER # W/ AUX ISO TRAILER SOCKET @ W/ LONESTAR</p>	<table border="1" style="width:100%; border-collapse: collapse;"> <thead> <tr> <th>CAV</th> <th>CIR</th> <th>GAUGE</th> <th>COLOR</th> <th>TERMINAL</th> </tr> </thead> <tbody> <tr><td>1</td><td>A72D</td><td>18</td><td>OR</td><td>1661224C1</td></tr> <tr><td>2B</td><td>A109C</td><td>18</td><td>GY</td><td>1661224C1</td></tr> <tr><td>2B*</td><td>A72EB</td><td>18</td><td>OR</td><td>1661224C1</td></tr> <tr><td>2B#@</td><td>A72B</td><td>16</td><td>OR</td><td>1661226C1</td></tr> <tr><td>3%#</td><td>A72-F</td><td>16</td><td>OR</td><td>1661226C1</td></tr> <tr><td>3%#@</td><td>A72-FA</td><td>18</td><td>OR</td><td>1661226C1</td></tr> <tr><td>3*%</td><td>A72ED</td><td>18</td><td>OR</td><td>3541250C1</td></tr> <tr><td>3*%</td><td>A72EC</td><td>18</td><td>OR</td><td>3541250C1</td></tr> <tr><td>3</td><td>A72C</td><td>18</td><td>OR</td><td>1661224C1</td></tr> <tr><td>4</td><td>-</td><td>-</td><td>-</td><td>-</td></tr> <tr><td>5B</td><td>-</td><td>-</td><td>-</td><td>-</td></tr> <tr><td>6</td><td>-</td><td>-</td><td>-</td><td>-</td></tr> <tr><td>7</td><td>A72B</td><td>14</td><td>OR</td><td>1661226C1</td></tr> <tr><td>7*</td><td>A72ED</td><td>18</td><td>OR</td><td>1661224C1</td></tr> <tr><td>7#@</td><td>A72FA</td><td>18</td><td>OR</td><td>1661224C1</td></tr> <tr><td>8</td><td>A62SC</td><td>18</td><td>DKBL</td><td>1661224C1</td></tr> <tr><td>9</td><td>A72-G</td><td>18</td><td>WH</td><td>1661224C1</td></tr> <tr><td>9#@</td><td>A72GB</td><td>18</td><td>WH</td><td>1661224C1</td></tr> <tr><td>10</td><td>A72-GB</td><td>18</td><td>WH</td><td>1661224C1</td></tr> </tbody> </table>	CAV	CIR	GAUGE	COLOR	TERMINAL	1	A72D	18	OR	1661224C1	2B	A109C	18	GY	1661224C1	2B*	A72EB	18	OR	1661224C1	2B#@	A72B	16	OR	1661226C1	3%#	A72-F	16	OR	1661226C1	3%#@	A72-FA	18	OR	1661226C1	3*%	A72ED	18	OR	3541250C1	3*%	A72EC	18	OR	3541250C1	3	A72C	18	OR	1661224C1	4	-	-	-	-	5B	-	-	-	-	6	-	-	-	-	7	A72B	14	OR	1661226C1	7*	A72ED	18	OR	1661224C1	7#@	A72FA	18	OR	1661224C1	8	A62SC	18	DKBL	1661224C1	9	A72-G	18	WH	1661224C1	9#@	A72GB	18	WH	1661224C1	10	A72-GB	18	WH	1661224C1
CAV	CIR	GAUGE	COLOR	TERMINAL																																																																																																	
1	A72D	18	OR	1661224C1																																																																																																	
2B	A109C	18	GY	1661224C1																																																																																																	
2B*	A72EB	18	OR	1661224C1																																																																																																	
2B#@	A72B	16	OR	1661226C1																																																																																																	
3%#	A72-F	16	OR	1661226C1																																																																																																	
3%#@	A72-FA	18	OR	1661226C1																																																																																																	
3*%	A72ED	18	OR	3541250C1																																																																																																	
3*%	A72EC	18	OR	3541250C1																																																																																																	
3	A72C	18	OR	1661224C1																																																																																																	
4	-	-	-	-																																																																																																	
5B	-	-	-	-																																																																																																	
6	-	-	-	-																																																																																																	
7	A72B	14	OR	1661226C1																																																																																																	
7*	A72ED	18	OR	1661224C1																																																																																																	
7#@	A72FA	18	OR	1661224C1																																																																																																	
8	A62SC	18	DKBL	1661224C1																																																																																																	
9	A72-G	18	WH	1661224C1																																																																																																	
9#@	A72GB	18	WH	1661224C1																																																																																																	
10	A72-GB	18	WH	1661224C1																																																																																																	

CHK	DATE	CHANGE	REV	REFERENCE	DRAWN	NAME
DLV1	19NOV09	RMVD CONNECTOR 1026.	C	63656A	U00K640	CIRCUIT DIAGRAM, PROSTAR, LONESTAR
					RELEASE NO. 59637L	DATE 06SEP06
						PART NO. AE08055906
						SHEET 017

Figure 249 Connector Composites (1100M), (1101M), (1110M)

14.21. CONNECTOR COMPOSITES (1111M), (1112M), (1113M), P. 18

INTERNATIONAL TRUCK AND ENGINE CORPORATION		ELECTRICAL CIRCUIT DIAGRAM		CHAPTER 14	
THIS PRINT IS PROVIDED ON A RESTRICTED BASIS AND IS NOT TO BE USED IN ANY WAY DETRIMENTAL TO THE INTEREST OF INTERNATIONAL TRUCK AND ENGINE CORPORATION.		CONNECTOR BODY COMPOSITE - MATING VIEW SHOWN			

PANIC BUTTON  
(1111M)  
(LOCATED IN INSTRUMENT PANEL CENTER)

CONNECTOR 3520850C1

CAV	CIR	GAUGE	COLOR	TERMINAL
1	-	-	-	-
2B*	A98NS	18	BK	1661224C1
2B#	A11-GSA	18	WH	1661224C1
3#	A98J	18	BK	1661224C1
3*	A98Z	18	BK	1661224C1
4	-	-	-	-
5B	-	-	-	-
6	-	-	-	-
7#	A62SDA	18	DKBL	1661224C1
7*	A98NL	18	BK	1661224C1
8#%	A62SDA	18	DKBL	3541250C1
	A62SD	18	DKBL	
8*	A62N	18	DKBL	1661224C1
9	-	-	-	-
10#	A11-GSB	18	WH	1661224C1
10*	A11-GN	18	WH	1661224C1

\* W/ TELEMATICS ALERT SWITCH  
# W/ QUALCOMM PANIC BUTTON  
% CRIMPED TOGETHER

SPARE # 1  
(1112M)  
(LOCATED IN INSTRUMENT PANEL CENTER)

CONNECTOR 3520850C1

CAV	CIR	GAUGE	COLOR	TERMINAL
1	-	-	-	-
2B	A14SA	18	RD	1661224C1
3%	A14SAA	18	RD	3541250C1
	A14SAB	18	RD	3541250C1
4	-	-	-	-
5B	-	-	-	-
6	-	-	-	-
7	A14SAA	18	RD	1661224C1
8	A62SA	18	DKBL	1661224C1
9	A14-GSA	18	WH	1661224C1
10	-	-	-	-

% CRIMPED TOGETHER

SPARE # 2  
(1113M)  
(LOCATED IN INSTRUMENT PANEL CENTER)

CONNECTOR 3520850C1

CAV	CIR	GAUGE	COLOR	TERMINAL
1	-	-	-	-
2B	A14SB	18	RD	1661224C1
3%	A14SBB	18	RD	3541250C1
	A14SBA	18	RD	3541250C1
4	-	-	-	-
5B	-	-	-	-
6	-	-	-	-
7	A14SBA	18	RD	1661224C1
8	A62SB	18	DKBL	1661224C1
9	A14-GSC	18	WH	1661224C1
10	-	-	-	-

% CRIMPED TOGETHER

CHK	DATE	CHANGE	REV	REFERENCE	DRAWN	NAME
CNA1	14JAN09	TITLE WAS CIRCUIT	B	61254R	U00K640	CIRCUIT DIAGRAM, PROSTAR, LONESTAR
		DIAGRAM, PROSTAR			59637L	DATE: 06SEP06 PART NO: AE08055906 SHEET: 018

Figure 250 Connector Composites (1111M), (1112M), (1113M)

14.22. CONNECTOR COMPOSITES (1114M), (1115M), (1116M), (1117M), P. 19

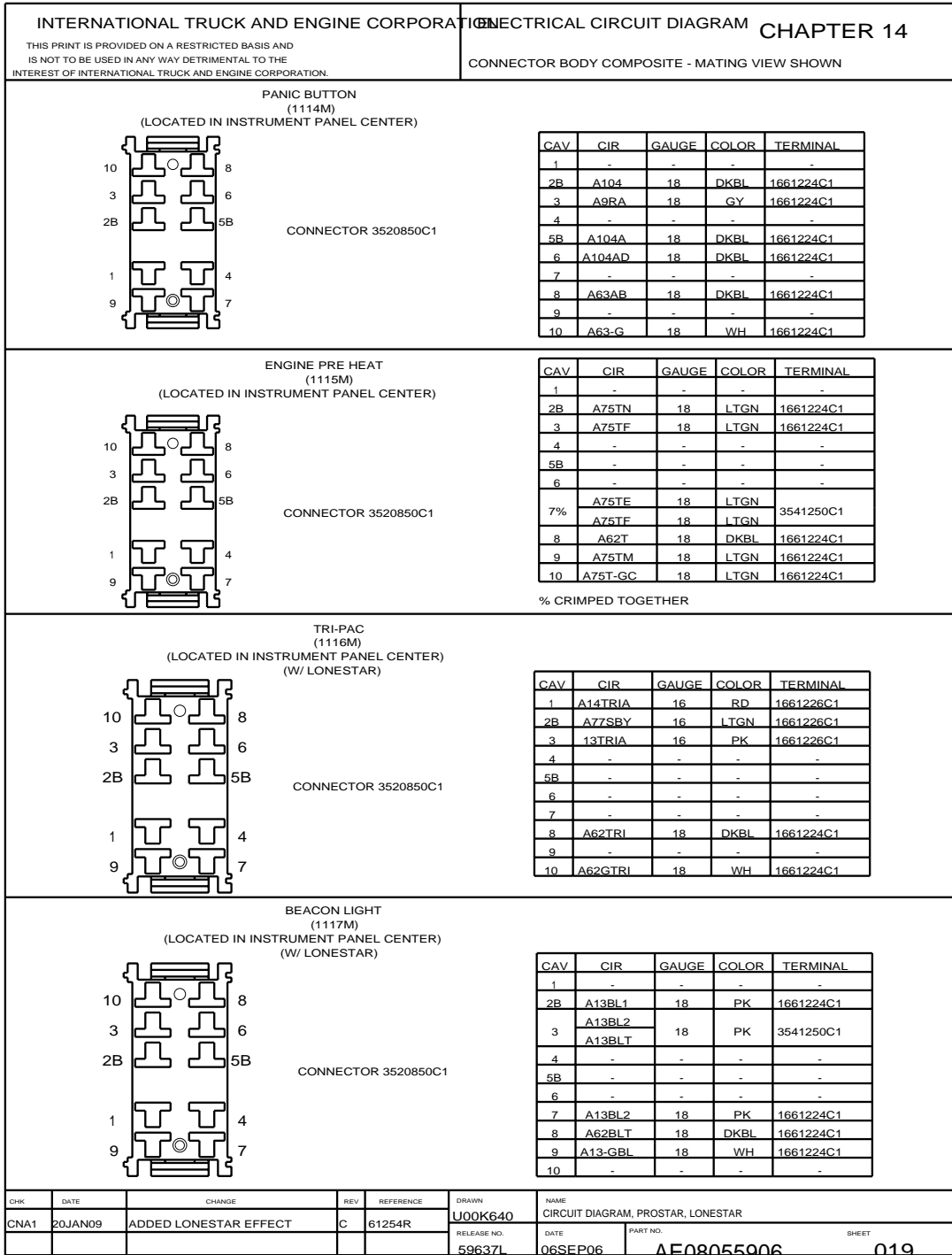


Figure 251 Connector Composites (1114M), (1115M), (1116M), (1117M)

14.23. CONNECTOR COMPOSITES (1200), (1210), (1215), P. 20

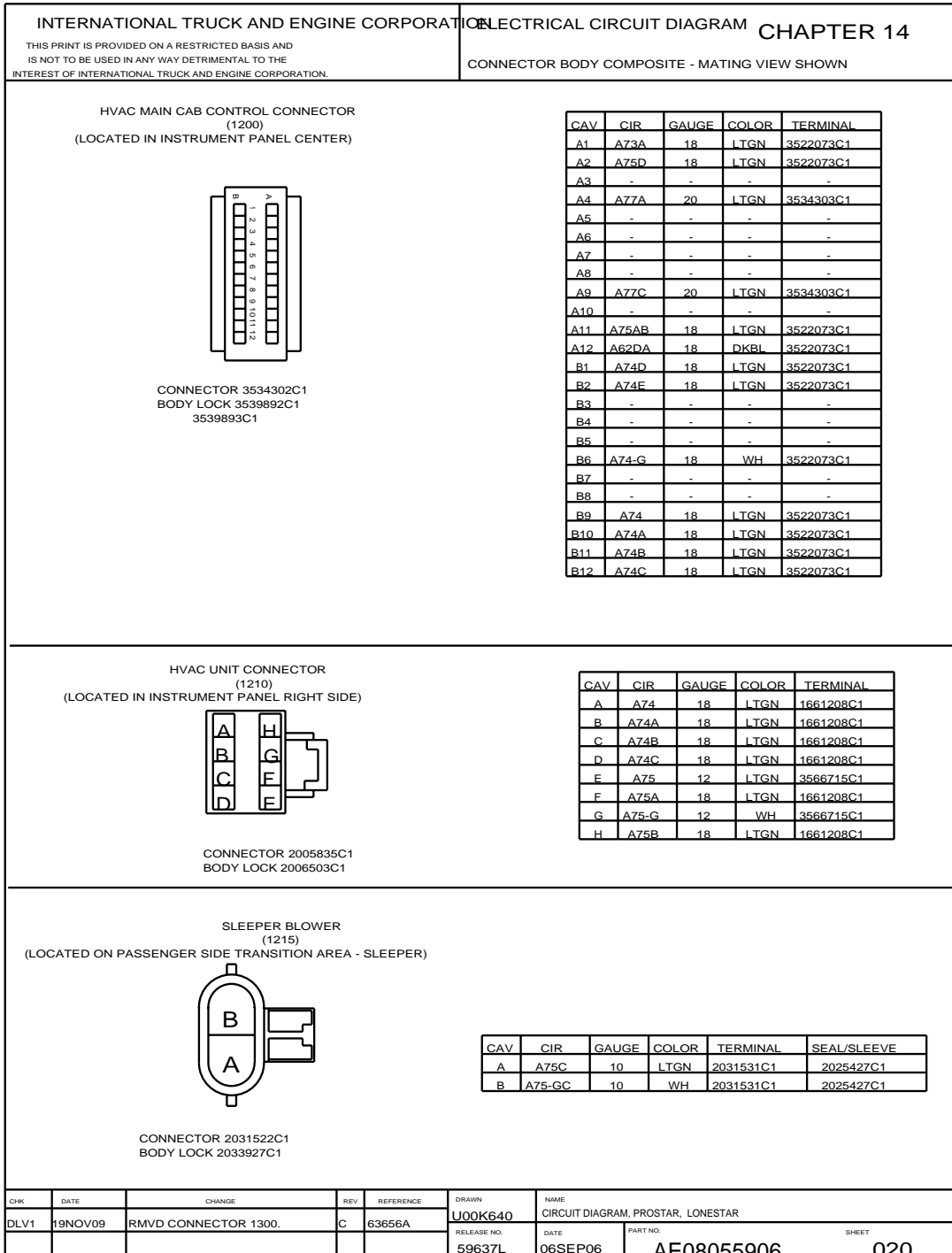


Figure 252 Connector Composites (1200), (1210), (1215)

14.24. CONNECTOR COMPOSITES (1300), (1301), P. 21

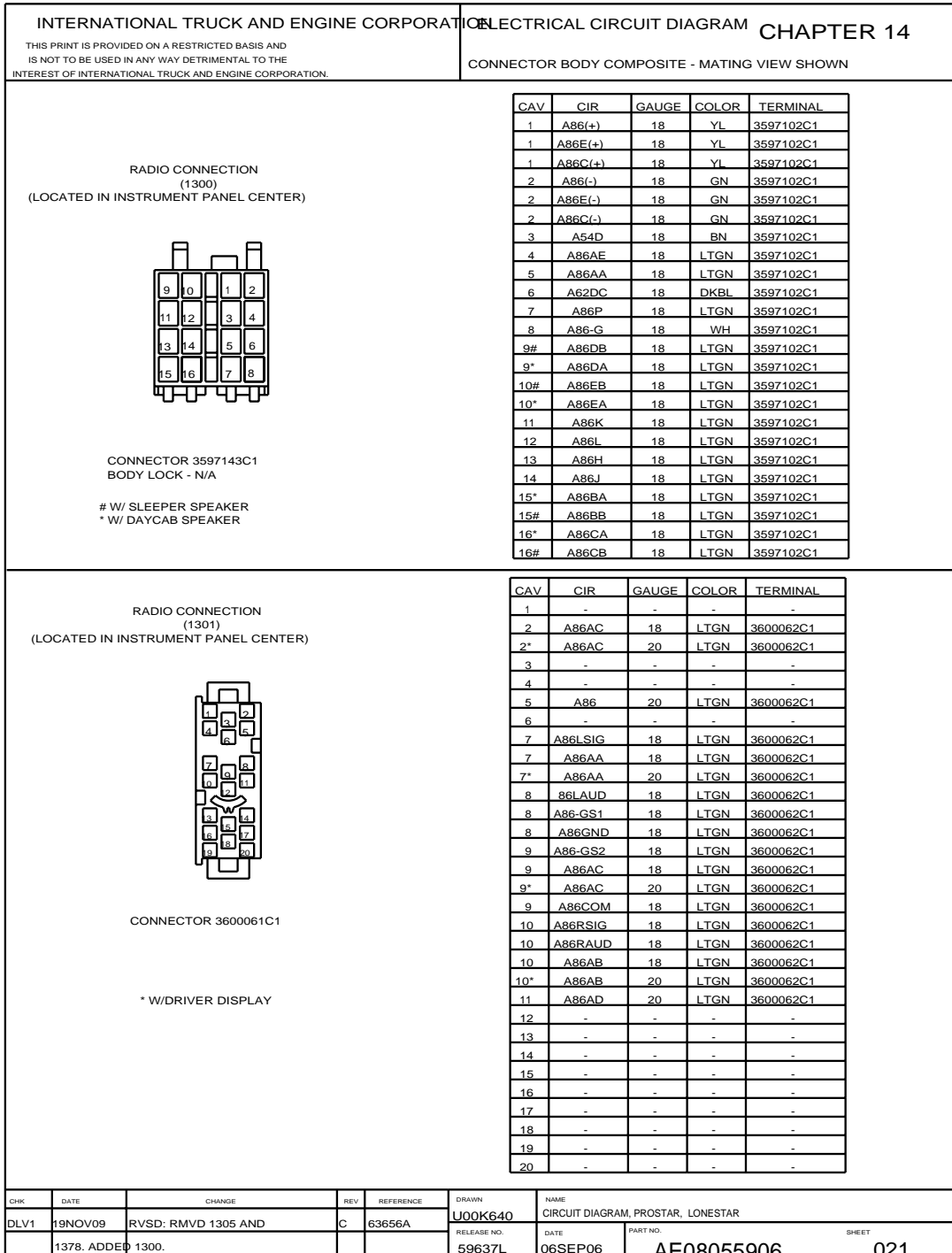



Figure 253 Connector Composites (1300), (1301)

14.25. CONNECTOR COMPOSITES (1305), (1378), P. 21A

<p>INTERNATIONAL TRUCK AND ENGINE CORPORATION</p> <p><small>THIS PRINT IS PROVIDED ON A RESTRICTED BASIS AND IS NOT TO BE USED IN ANY WAY DETRIMENTAL TO THE INTEREST OF INTERNATIONAL TRUCK AND ENGINE CORPORATION.</small></p>	<p>ELECTRICAL CIRCUIT DIAGRAM CHAPTER 14</p> <p>CONNECTOR BODY COMPOSITE - MATING VIEW SHOWN</p>
--	--

BUNK FAN  
(1305)  
(LOCATED IN ROOF ON PASSENGER SIDE - SLEEPER)

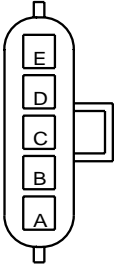


CAV	CIR	GAUGE	COLOR	TERMINAL
A	H76	18	BK	0333732C1
B	H76-G	18	WH	0333732C1

CONNECTOR 0969541R1

COOLANT MODULE  
(1378)  
(LOCATED AT UPPER LEFT SIDE OF ENGINE)



CAV	CIR	GAUGE	COLOR	TERMINAL	SEAL/SLEEVE
A	K97FB	18	VT	2033819C1	1652325C1
B	K34	16	TN	2033819C1	1652325C1
C	K34E	16	TN	2033819C1	1652325C1
D	K34A2	16	TN	2033819C1	1652325C1
E	PLUG	-	-	0587579C1	-

CONNECTOR 1687789C1  
BODY LOCK 1661376C1

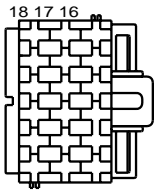
CHK	DATE	CHANGE	REV	REFERENCE	DRAWN	NAME
DLV1	19NOV09	INITIAL RELEASE.	A	63656A	U00SLK3	CIRCUIT DIAGRAM, PROSTAR, LONESTAR
					RELEASE NO. 63656A	DATE 19OCT09
						PART NO. AE08055906
						SHEET 21A

Figure 254 Connector Composites (1305), (1378)

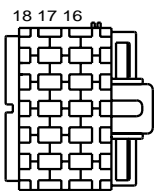
14.26. CONNECTOR COMPOSITES (1400), (1401), (1402), P. 22

INTERNATIONAL TRUCK AND ENGINE CORPORATION				ELECTRICAL CIRCUIT DIAGRAM CHAPTER 14			
THIS PRINT IS PROVIDED ON A RESTRICTED BASIS AND IS NOT TO BE USED IN ANY WAY DETRIMENTAL TO THE INTEREST OF INTERNATIONAL TRUCK AND ENGINE CORPORATION.				CONNECTOR BODY COMPOSITE - MATING VIEW SHOWN			

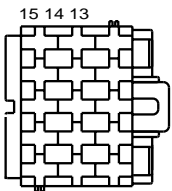
  

<p style="text-align: center;">ABS # 1 (1400) (LOCATED ON RIGHT-SIDE KICK PANEL - ABS MODULE)</p>  <p style="text-align: center;">3 2 1</p> <p style="text-align: center;">CONNECTOR 3596926C1 BODY LOCK 3562309C1</p>	<table border="1" style="width:100%; border-collapse: collapse; font-size: x-small;"> <thead> <tr> <th>CAV</th> <th>CIR</th> <th>GAUGE</th> <th>COLOR</th> <th>TERMINAL</th> </tr> </thead> <tbody> <tr><td>1</td><td>A94-GA</td><td>12</td><td>WH</td><td>3597157C1</td></tr> <tr><td>2</td><td>-</td><td>-</td><td>-</td><td>-</td></tr> <tr><td>3</td><td>A94V</td><td>18</td><td>GY</td><td>3598072C1</td></tr> <tr><td>4</td><td>A94BN</td><td>18</td><td>GY</td><td>3598072C1</td></tr> <tr><td>5</td><td>A94BM</td><td>18</td><td>GY</td><td>3598072C1</td></tr> <tr><td>6</td><td>-</td><td>-</td><td>-</td><td>-</td></tr> <tr><td>7</td><td>A5N(-)</td><td>18</td><td>GN</td><td>3598072C1</td></tr> <tr><td>8</td><td>A5N(+)</td><td>18</td><td>YL</td><td>3598072C1</td></tr> <tr><td>9</td><td>-</td><td>-</td><td>-</td><td>-</td></tr> <tr><td>10</td><td>A94BH</td><td>16</td><td>GY</td><td>3598073C1</td></tr> <tr><td>11</td><td>A94BF</td><td>16</td><td>GY</td><td>3598073C1</td></tr> <tr><td>12</td><td>A94-GB</td><td>16</td><td>WH</td><td>3548970C1</td></tr> <tr><td>13</td><td>A3BA(-)</td><td>18</td><td>GY</td><td>3598072C1</td></tr> <tr><td>14</td><td>A3BA(+)</td><td>18</td><td>DKBL</td><td>3598072C1</td></tr> <tr><td>15</td><td>-</td><td>-</td><td>-</td><td>-</td></tr> <tr><td>16</td><td>A94AY</td><td>12</td><td>GY</td><td>3597157C1</td></tr> <tr><td>17</td><td>-</td><td>-</td><td>-</td><td>-</td></tr> <tr><td>18</td><td>-</td><td>-</td><td>-</td><td>-</td></tr> </tbody> </table>	CAV	CIR	GAUGE	COLOR	TERMINAL	1	A94-GA	12	WH	3597157C1	2	-	-	-	-	3	A94V	18	GY	3598072C1	4	A94BN	18	GY	3598072C1	5	A94BM	18	GY	3598072C1	6	-	-	-	-	7	A5N(-)	18	GN	3598072C1	8	A5N(+)	18	YL	3598072C1	9	-	-	-	-	10	A94BH	16	GY	3598073C1	11	A94BF	16	GY	3598073C1	12	A94-GB	16	WH	3548970C1	13	A3BA(-)	18	GY	3598072C1	14	A3BA(+)	18	DKBL	3598072C1	15	-	-	-	-	16	A94AY	12	GY	3597157C1	17	-	-	-	-	18	-	-	-	-
CAV	CIR	GAUGE	COLOR	TERMINAL																																																																																												
1	A94-GA	12	WH	3597157C1																																																																																												
2	-	-	-	-																																																																																												
3	A94V	18	GY	3598072C1																																																																																												
4	A94BN	18	GY	3598072C1																																																																																												
5	A94BM	18	GY	3598072C1																																																																																												
6	-	-	-	-																																																																																												
7	A5N(-)	18	GN	3598072C1																																																																																												
8	A5N(+)	18	YL	3598072C1																																																																																												
9	-	-	-	-																																																																																												
10	A94BH	16	GY	3598073C1																																																																																												
11	A94BF	16	GY	3598073C1																																																																																												
12	A94-GB	16	WH	3548970C1																																																																																												
13	A3BA(-)	18	GY	3598072C1																																																																																												
14	A3BA(+)	18	DKBL	3598072C1																																																																																												
15	-	-	-	-																																																																																												
16	A94AY	12	GY	3597157C1																																																																																												
17	-	-	-	-																																																																																												
18	-	-	-	-																																																																																												

<p style="text-align: center;">ABS # 2 (1401) (LOCATED ON RIGHT-SIDE KICK PANEL ABS MODULE)</p>  <p style="text-align: center;">3 2 1</p> <p style="text-align: center;">CONNECTOR 3596929C1</p>	<table border="1" style="width:100%; border-collapse: collapse; font-size: x-small;"> <thead> <tr> <th>CAV</th> <th>CIR</th> <th>GAUGE</th> <th>COLOR</th> <th>TERMINAL</th> </tr> </thead> <tbody> <tr><td>1</td><td>A94B</td><td>18</td><td>GY</td><td>3598072C1</td></tr> <tr><td>2</td><td>A94</td><td>18</td><td>GY</td><td>3598072C1</td></tr> <tr><td>3</td><td>A94A</td><td>18</td><td>GY</td><td>3598072C1</td></tr> <tr><td>4</td><td>A94K</td><td>18</td><td>GY</td><td>3598072C1</td></tr> <tr><td>5</td><td>A94C</td><td>16</td><td>GY</td><td>3598073C1</td></tr> <tr><td>6</td><td>A94J</td><td>18</td><td>GY</td><td>3598072C1</td></tr> <tr><td>7</td><td>A94H</td><td>18</td><td>GY</td><td>3598072C1</td></tr> <tr><td>8</td><td>A94D</td><td>16</td><td>GY</td><td>3598073C1</td></tr> <tr><td>9</td><td>A94BK</td><td>18</td><td>GY</td><td>3598072C1</td></tr> <tr><td>10</td><td>A94BL</td><td>18</td><td>GY</td><td>3598072C1</td></tr> <tr><td>11</td><td>A94E</td><td>16</td><td>GY</td><td>3598073C1</td></tr> <tr><td>12</td><td>A94BB</td><td>18</td><td>GY</td><td>3598072C1</td></tr> <tr><td>13</td><td>A94BJ</td><td>18</td><td>GY</td><td>3598072C1</td></tr> <tr><td>14</td><td>A94F</td><td>16</td><td>GY</td><td>3598073C1</td></tr> <tr><td>15</td><td>A94BE</td><td>16</td><td>GY</td><td>3598073C1</td></tr> <tr><td>16</td><td>A94BC</td><td>18</td><td>GY</td><td>3598072C1</td></tr> <tr><td>17</td><td>A94BA</td><td>18</td><td>GY</td><td>3598072C1</td></tr> <tr><td>18</td><td>A94BD</td><td>16</td><td>GY</td><td>3598073C1</td></tr> </tbody> </table>	CAV	CIR	GAUGE	COLOR	TERMINAL	1	A94B	18	GY	3598072C1	2	A94	18	GY	3598072C1	3	A94A	18	GY	3598072C1	4	A94K	18	GY	3598072C1	5	A94C	16	GY	3598073C1	6	A94J	18	GY	3598072C1	7	A94H	18	GY	3598072C1	8	A94D	16	GY	3598073C1	9	A94BK	18	GY	3598072C1	10	A94BL	18	GY	3598072C1	11	A94E	16	GY	3598073C1	12	A94BB	18	GY	3598072C1	13	A94BJ	18	GY	3598072C1	14	A94F	16	GY	3598073C1	15	A94BE	16	GY	3598073C1	16	A94BC	18	GY	3598072C1	17	A94BA	18	GY	3598072C1	18	A94BD	16	GY	3598073C1
CAV	CIR	GAUGE	COLOR	TERMINAL																																																																																												
1	A94B	18	GY	3598072C1																																																																																												
2	A94	18	GY	3598072C1																																																																																												
3	A94A	18	GY	3598072C1																																																																																												
4	A94K	18	GY	3598072C1																																																																																												
5	A94C	16	GY	3598073C1																																																																																												
6	A94J	18	GY	3598072C1																																																																																												
7	A94H	18	GY	3598072C1																																																																																												
8	A94D	16	GY	3598073C1																																																																																												
9	A94BK	18	GY	3598072C1																																																																																												
10	A94BL	18	GY	3598072C1																																																																																												
11	A94E	16	GY	3598073C1																																																																																												
12	A94BB	18	GY	3598072C1																																																																																												
13	A94BJ	18	GY	3598072C1																																																																																												
14	A94F	16	GY	3598073C1																																																																																												
15	A94BE	16	GY	3598073C1																																																																																												
16	A94BC	18	GY	3598072C1																																																																																												
17	A94BA	18	GY	3598072C1																																																																																												
18	A94BD	16	GY	3598073C1																																																																																												

<p style="text-align: center;">ABS # 3 (1402) (LOCATED ON RIGHT-SIDE KICK PANEL ABS MODULE)</p>  <p style="text-align: center;">3 2 1</p> <p style="text-align: center;">CONNECTOR 3596928C1</p>	<table border="1" style="width:100%; border-collapse: collapse; font-size: x-small;"> <thead> <tr> <th>CAV</th> <th>CIR</th> <th>GAUGE</th> <th>COLOR</th> <th>TERMINAL</th> </tr> </thead> <tbody> <tr><td>1</td><td>-</td><td>-</td><td>-</td><td>-</td></tr> <tr><td>2</td><td>-</td><td>-</td><td>-</td><td>-</td></tr> <tr><td>3</td><td>A94SK</td><td>18</td><td>GY</td><td>3598072C1</td></tr> <tr><td>4*</td><td>A94BP</td><td>16</td><td>GY</td><td>3598073C1</td></tr> <tr><td>5</td><td>A94SJ</td><td>18</td><td>GY</td><td>3598072C1</td></tr> <tr><td>6*</td><td>A94BN</td><td>16</td><td>GY</td><td>3598073C1</td></tr> <tr><td>7*</td><td>A94BM</td><td>16</td><td>GY</td><td>3598073C1</td></tr> <tr><td>8</td><td>-</td><td>-</td><td>-</td><td>-</td></tr> <tr><td>9*</td><td>A94BT</td><td>16</td><td>GY</td><td>3598073C1</td></tr> <tr><td>10*</td><td>A94BU</td><td>16</td><td>GY</td><td>3598073C1</td></tr> <tr><td>11*</td><td>A94BR</td><td>16</td><td>GY</td><td>3598073C1</td></tr> <tr><td>12*</td><td>A94BW</td><td>16</td><td>GY</td><td>3598073C1</td></tr> <tr><td>13*</td><td>A94BS</td><td>16</td><td>GY</td><td>3598073C1</td></tr> <tr><td>14*</td><td>A94BQ</td><td>16</td><td>GY</td><td>3598073C1</td></tr> <tr><td>15*</td><td>A94RV</td><td>16</td><td>GY</td><td>3598073C1</td></tr> </tbody> </table> <p style="text-align: center;">* W/ LONESTAR</p>	CAV	CIR	GAUGE	COLOR	TERMINAL	1	-	-	-	-	2	-	-	-	-	3	A94SK	18	GY	3598072C1	4*	A94BP	16	GY	3598073C1	5	A94SJ	18	GY	3598072C1	6*	A94BN	16	GY	3598073C1	7*	A94BM	16	GY	3598073C1	8	-	-	-	-	9*	A94BT	16	GY	3598073C1	10*	A94BU	16	GY	3598073C1	11*	A94BR	16	GY	3598073C1	12*	A94BW	16	GY	3598073C1	13*	A94BS	16	GY	3598073C1	14*	A94BQ	16	GY	3598073C1	15*	A94RV	16	GY	3598073C1
CAV	CIR	GAUGE	COLOR	TERMINAL																																																																													
1	-	-	-	-																																																																													
2	-	-	-	-																																																																													
3	A94SK	18	GY	3598072C1																																																																													
4*	A94BP	16	GY	3598073C1																																																																													
5	A94SJ	18	GY	3598072C1																																																																													
6*	A94BN	16	GY	3598073C1																																																																													
7*	A94BM	16	GY	3598073C1																																																																													
8	-	-	-	-																																																																													
9*	A94BT	16	GY	3598073C1																																																																													
10*	A94BU	16	GY	3598073C1																																																																													
11*	A94BR	16	GY	3598073C1																																																																													
12*	A94BW	16	GY	3598073C1																																																																													
13*	A94BS	16	GY	3598073C1																																																																													
14*	A94BQ	16	GY	3598073C1																																																																													
15*	A94RV	16	GY	3598073C1																																																																													

CHK	DATE	CHANGE	REV	REFERENCE	DRAWN	NAME
CNA1	14JAN09	ADDED LONESTAR EFFECT	A	61254R	U00K640	CIRCUIT DIAGRAM, PROSTAR, LONESTAR
					RELEASE NO. 59637L	DATE 06SEP06 PART NO. AE08055906 SHEET 022

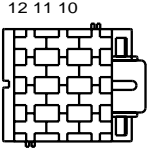
Figure 255 Connector Composites (1400), (1401), (1402)

14.27. CONNECTOR COMPOSITES (1403), (1410), (1420), P. 23

INTERNATIONAL TRUCK AND ENGINE CORPORATION		ELECTRICAL CIRCUIT DIAGRAM		CHAPTER 14	
THIS PRINT IS PROVIDED ON A RESTRICTED BASIS AND IS NOT TO BE USED IN ANY WAY DETRIMENTAL TO THE INTEREST OF INTERNATIONAL TRUCK AND ENGINE CORPORATION.		CONNECTOR BODY COMPOSITE - MATING VIEW SHOWN			

ABS #4  
(1403)  
(LOCATED ON RIGHT-SIDE KICK PANEL ABS MODULE)

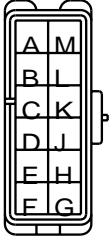


CONNECTOR 3596927C1

CAV	CIR	GAUGE	COLOR	TERMINAL
1	A94SZD	16	GY	3598073C1
2	A94SE	18	GY	3598072C1
3	A94SH	16	GY	3598073C1
4	A94SVD	16	GY	3598073C1
5	A94SF	16	GY	3598073C1
6	A94SL	18	GY	3598072C1
7	A94SDA	18	GY	3598072C1
8	A94SBA	18	GY	3598072C1
9	A94SM	18	GY	3598072C1
10	A94SCA	18	GY	3598072C1
11	A94SAA	18	GY	3598072C1
12	A94SN	18	GY	3598072C1

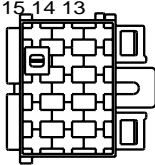
ABS ATC & RSP  
SPLICE PACK  
(1410)  
(LOCATED IN INSTRUMENT PANEL - CENTER)



CONNECTOR 3601838C1  
BODY LOCK 3601839C1

CAV	CIR	GAUGE	COLOR	TERMINAL
A	A94SAA	18	GY	3534164C1
B	A94SAB	18	GY	3534164C1
C	A94SA	18	GY	3534164C1
D	A94SCA	18	GY	3534164C1
E	A94SCB	18	GY	3534164C1
F	A94SC	18	GY	3534164C1
G	A94SBA	18	GY	3534164C1
H	A94SBB	18	GY	3534164C1
J	A94SB	18	GY	3534164C1
K	A94SDA	18	GY	3534164C1
L	A94SDB	18	GY	3534164C1
M	A94SD	18	GY	3534164C1

WABCO ABS CONN  
(1420)  
(LOCATED ON RIGHT-SIDE KICK PANEL - ABS MODULE)



CONNECTOR 3557922C1  
BODY LOCK 3549120C1

CAV	CIRCUIT	GAUGE	COLOR	TERMINAL
1	A5N(-)	18	GN	3548971C1
2	-	-	-	-
3	A5N(+)	18	YL	3548971C1
4	A94-GB	18	WH	3548971C1
5	-	-	-	-
6	-	-	-	-
7	A94V	18	GY	3548971C1
7*	A94V	14	GY	3548972C1
8	A94AY	18	GY	3548971C1
8*	A94AY	14	GY	3548972C1
9	A94-GA	18	WH	3548969C1
10	A3BA(-)	18	GY	3548971C1
11	A3BA(+)	18	DK BL	3548971C1
12	-	-	-	-
13	-	-	-	-
14	-	-	-	-
15	-	-	-	-

\* W/ LONESTAR

CHK	DATE	CHANGE	REV	REFERENCE	DRAWN	NAME
CNA1	14JAN09	ADDED LONESTAR EFFECT	A	61254R	U00K640	CIRCUIT DIAGRAM, PROSTAR, LONESTAR
					RELEASE NO.	DATE
					59637L	06SEP06
						PART NO.
						AE08055906
						SHEET
						023

Figure 256 Connector Composites (1403), (1410), (1420)

14.28. CONNECTOR COMPOSITES (1421), (1422), (1423), P. 24

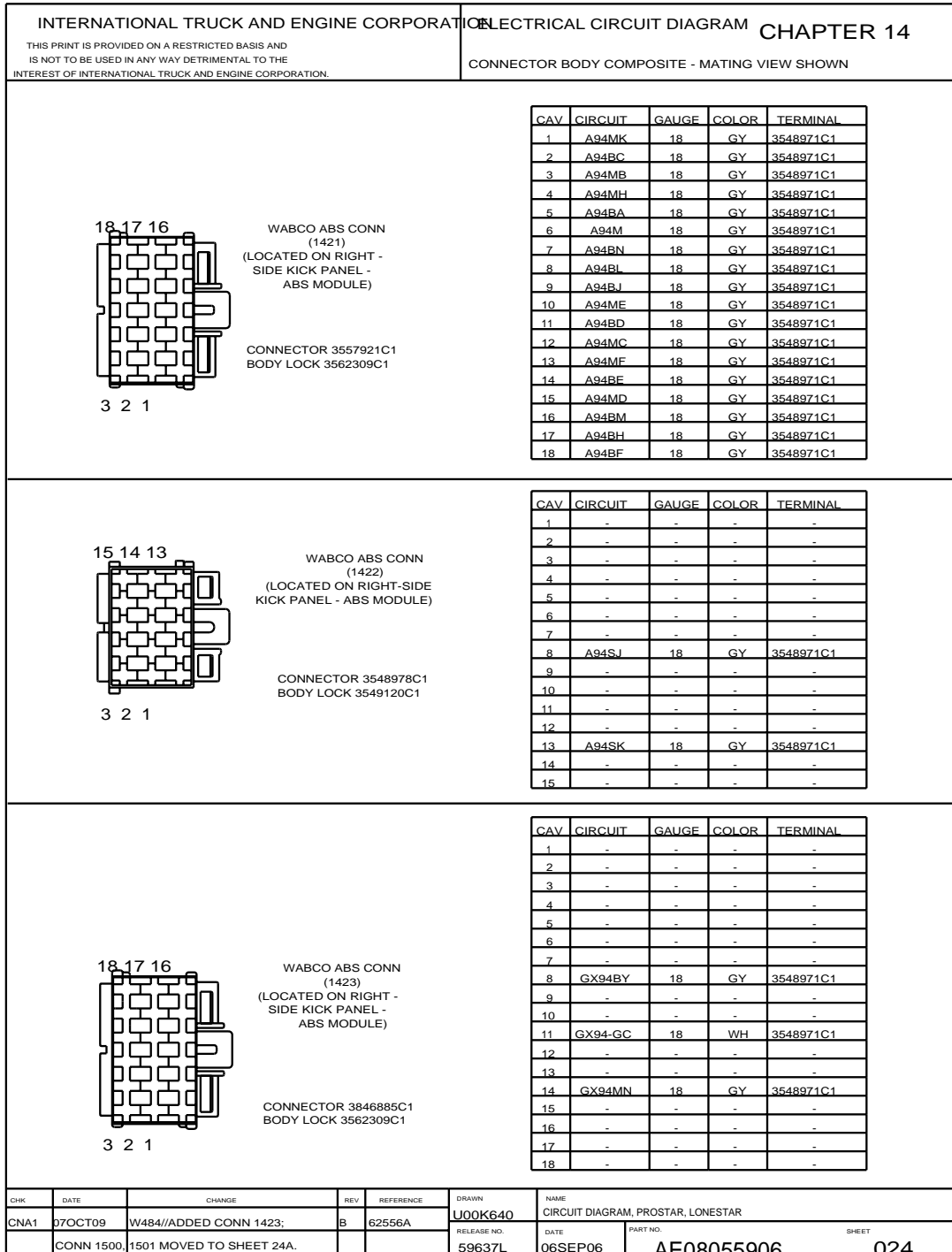


Figure 257 Connector Composites (1421), (1422), (1423)

14.29. CONNECTOR COMPOSITES (1500), (1501), P. 24A

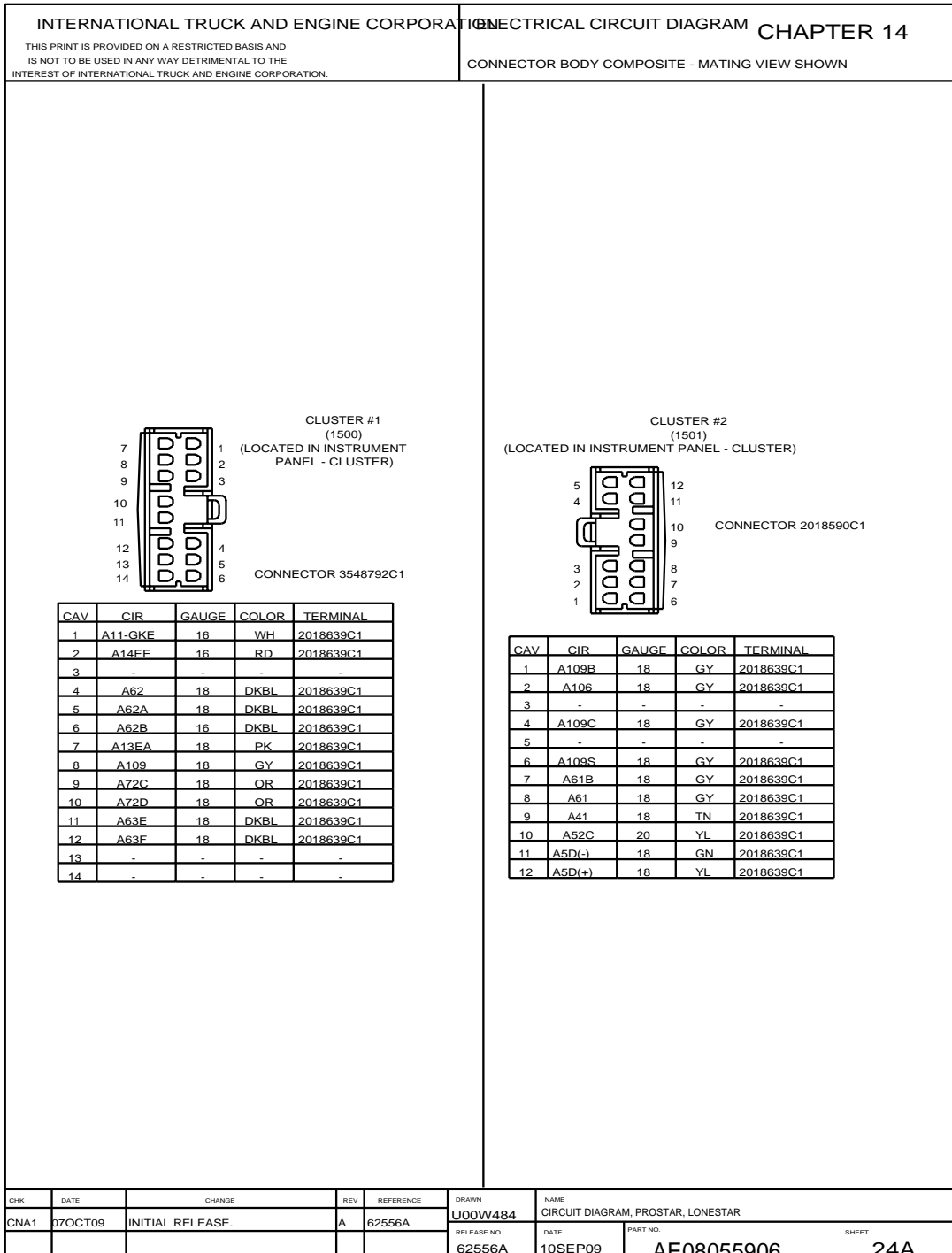


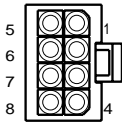
Figure 258 Connector Composites (1500), (1501)

14.30. CONNECTOR COMPOSITES (1502), (1510), P. 25

<p>INTERNATIONAL TRUCK AND ENGINE CORPORATION THIS PRINT IS PROVIDED ON A RESTRICTED BASIS AND IS NOT TO BE USED IN ANY WAY DETRIMENTAL TO THE INTEREST OF INTERNATIONAL TRUCK AND ENGINE CORPORATION.</p>	<p>ELECTRICAL CIRCUIT DIAGRAM CHAPTER 14 CONNECTOR BODY COMPOSITE - MATING VIEW SHOWN</p>
--	---

SECONDARY INSTRUMENT CLUSTER  
(1502)  
(LOCATED IN INSTRUMENT PANEL - CENTER)

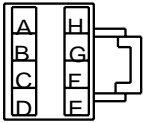


CONNECTOR 3534177C1

CAV	CIR	GAUGE	COLOR	TERMINAL
1	A14EF	18	RD	3534193C1
2	A13EH	18	PK	3534193C1
3	-	-	-	-
4	A5J(-)	18	GN	3534193C1
5	A11-GSF	16	WH	3534193C1
6	A62BH	18	DKBL	3534193C1
7	A5J(+)	18	YL	3534193C1
8	-	-	-	-

RIGHT BANK OPTIONAL  
WARNING LIGHTS  
(1510)  
(LOCATED IN INSTRUMENT PANEL - RIGHT REAR OF CLUSTER)



CONNECTOR 2005835C1  
BODY LOCK 2006503C1

CAV	CIR	GAUGE	COLOR	TERMINAL
A	A63-GC	18	WH	1661208C1
B	A13BA	20	PK	1661208C1
C	A13BB	20	PK	1661208C1
D	A13BC	20	PK	1661208C1
E	A49	18	GY	1661208C1
E*	A95H	18	TN	1661208C1
F	A24A	18	GY	1661208C1
G	A49A	18	GY	1661208C1
G*	A95F	18	TN	1661208C1
H	A63AV	18	DKBL	1661208C1

\* W/ LONESTAR

CHK	DATE	CHANGE	REV	REFERENCE	DRAWN	NAME
CNA1	20JAN09	ADDED LONESTAR EFFECT	A	61254R	U00K640	CIRCUIT DIAGRAM, PROSTAR, LONESTAR
					RELEASE NO. 59637L	DATE 06SEP06
						PART NO. AE08055906
						SHEET 025

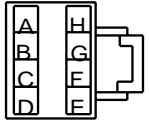
Figure 259 Connector Composites (1502), (1510)

14.31. CONNECTOR COMPOSITES (1511), (1550), (1556), P. 26

<p>INTERNATIONAL TRUCK AND ENGINE CORPORATION</p> <p>THIS PRINT IS PROVIDED ON A RESTRICTED BASIS AND IS NOT TO BE USED IN ANY WAY DETRIMENTAL TO THE INTEREST OF INTERNATIONAL TRUCK AND ENGINE CORPORATION.</p>	<p>ELECTRICAL CIRCUIT DIAGRAM CHAPTER 14</p> <p>CONNECTOR BODY COMPOSITE - MATING VIEW SHOWN</p>
---	--

LEFT BANK OPTIONAL  
WARNING LIGHTS  
(1511)  
(LOCATED IN INSTRUMENT PANEL - LEFT REAR OF CLUSTER)



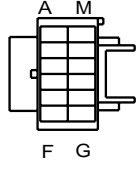
CAV	CIR	GAUGE	COLOR	TERMINAL
A*	A97W	18	PL	1661208C1
A#	A1A	18	PK	1661208C1
B	A13BD	20	PK	1661208C1
C	A13BE	20	PK	1661208C1
D	A13BF	20	PK	1661208C1
E	A49	18	GY	1661208C1
F@	A98F	18	BK	1661208C1
F@@	A98F	18	TN	1661208C1
F##	A98F	18	LTGN	1661208C1
G	A49A	18	GY	1661208C1
H*	A97V	18	PL	1661208C1
H#	A1	18	LTBL	1661208C1

CONNECTOR 2005835C1  
BODY LOCK 2006503C1

@@ W/ SLEEPER CAB  
@ W/ DAY CAB  
\* W/ IDLE REDUCTION  
# ALTERNATOR WARNING LIGHT  
## MOTIENT MOBILE MAX - SLEEPER / DAYCAB

VEHICLE INFORMATION DISPLAY  
(1550)  
(LOCATED IN INSTRUMENT PANEL - CENTER)



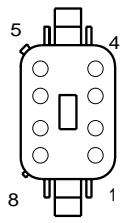
CAV	CIR	GAUGE	COLOR	TERMINAL
A	-	-	-	-
B	A12C	18	LTBL	3522073C1
C	A5L(-)	18	GN	3522073C1
D	A3BC(+)	20	DKBL	3534303C1
E	-	-	-	-
F	-	-	-	-
G	-	-	-	-
H	-	-	-	-
J	A11-GKH	18	WH	3522073C1
K	A3BC(-)	20	GY	3534303C1
L	A5L(+)	18	YL	3522073C1
M*	A14SE	18	RD	3522073C1
M	A14SE	18	PK	3522073C1

CONNECTOR 3609945C1  
BODY LOCK 3609946C1  
3609947C1

\* W/ TIRE PRESSURE

CAT MESSENGER DISPLAY  
(1556)  
(LOCATED IN INSTRUMENT PANEL CENTER)  
(W/ LONESTAR)



CAV	CIR	GAUGE	COLOR	TERMINAL
1	A14SE	18	RD	1680205C1
2	A11-GSE	18	WH	1680205C1
3	A13SE	18	PK	1680205C1
4	A62BB	18	DKBL	1680205C1
5	A3BC(-)	18	GY	1680205C1
6	A3BC(+)	18	DKBL	1680205C1
7	PLUG	-	-	0453133C1
8	PLUG	-	-	0453133C1

CONNECTOR 3534763C1  
BODY LOCK 3534766C1

CHK	DATE	CHANGE	REV	REFERENCE	DRAWN	NAME
CNA1	14JAN09	ADDED LONESTAR EFFECT	C	61254R	U00K640	CIRCUIT DIAGRAM, PROSTAR, LONESTAR
					RELEASE NO. 59637L	DATE 06SEP06
						PART NO. AE08055906
						SHEET 026

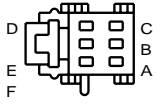
Figure 260 Connector Composites (1511), (1550), (1556)

14.32. CONNECTOR COMPOSITES (1557), (1600), P. 27

<p>INTERNATIONAL TRUCK AND ENGINE CORPORATION</p> <p>THIS PRINT IS PROVIDED ON A RESTRICTED BASIS AND IS NOT TO BE USED IN ANY WAY DETRIMENTAL TO THE INTEREST OF INTERNATIONAL TRUCK AND ENGINE CORPORATION.</p>	<p>ELECTRICAL CIRCUIT DIAGRAM CHAPTER 14</p> <p>CONNECTOR BODY COMPOSITE - MATING VIEW SHOWN</p>
---	--

ROAD RELAY FOR DISPLAY POWER  
(1557)  
(LOCATED IN INSTRUMENT PANEL - CENTER)  
(W/ LONESTAR)

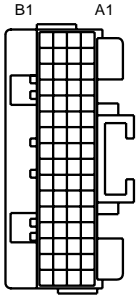


CONNECTOR 2031871C1  
BODY LOCK 2031873C1

CAV	CIR	GAUGE	COLOR	TERMINAL
A	A11-GSE	18	WH	1661261C1
B	A14SE	18	RD	1661261C1
C	A13SE	18	PK	1661261C1
D	A3BC(-)	20	GY	3544254C1
E	A3BC(+)	20	DKBL	3544254C1
F	A62BB	18	DKBL	1661261C1

BODY CONTROLLER # J3  
(1600)  
(LOCATED ON LEFT-SIDE KICK PANEL - BODY CONTROLLER)



CONNECTOR 3598706C1  
BODY LOCK 1618846C1  
1618847C1

CAV	CIR	GAUGE	COLOR	TERMINAL
A1	A12CV	18	LTBL	3522073C1
A2	A77A	20	LTGN	3534303C1
A3	A77C	20	LTGN	3534303C1
A4	A52D	20	YL	3534303C1
A5	A85A	20	GY	3534303C1
A6	A57B	20	OR	3534303C1
A7	A56B	20	OR	3534303C1
A8	A87A	18	GY	3522073C1
A9	A82A	20	GY	3534303C1
A10	A82B	20	GY	3534303C1
A11	A82C	20	GY	3534303C1
A12	A44	20	GY	3534303C1
A13	A63A	18	DKBL	3522073C1
A14	A102A	20	YL	3534303C1
A15	A87B	20	GY	3534303C1
A16	A13	18	PK	3522073C1
B1	A100	20	GY	3534303C1
B2	A40	20	GY	3534303C1
B3	A40A	20	GY	3534303C1
B4	A97A	18	PL	3522073C1
B5	A77E	20	LTGN	3534303C1
B6	A30	16	TN	3522073C1
B7	A31	18	TN	3522073C1
B8	A36B	18	TN	3522073C1
B9	A36A	18	TN	3522073C1
B10	A32	18	TN	3522073C1
B11	A32A	18	TN	3522073C1
B12	A77B	20	LTGN	3534303C1
B13	A77D	20	LTGN	3534303C1
B14	A40B	18	GY	3522073C1
B15	A75AA	18	LTGN	3522073C2
B16	A97	20	PL	3534303C1

CHK	DATE	CHANGE	REV	REFERENCE	DRAWN	NAME
CNA1	14JAN09	ADDED LONESTAR EFFECT	B	61254R	U00K640	CIRCUIT DIAGRAM, PROSTAR, LONESTAR
					RELEASE NO. 59637L	DATE 06SEP06
						PART NO. AE08055906
						SHEET 027

Figure 261 Connector Composites (1557), (1600)

14.33. CONNECTOR COMPOSITE (1601), P. 28

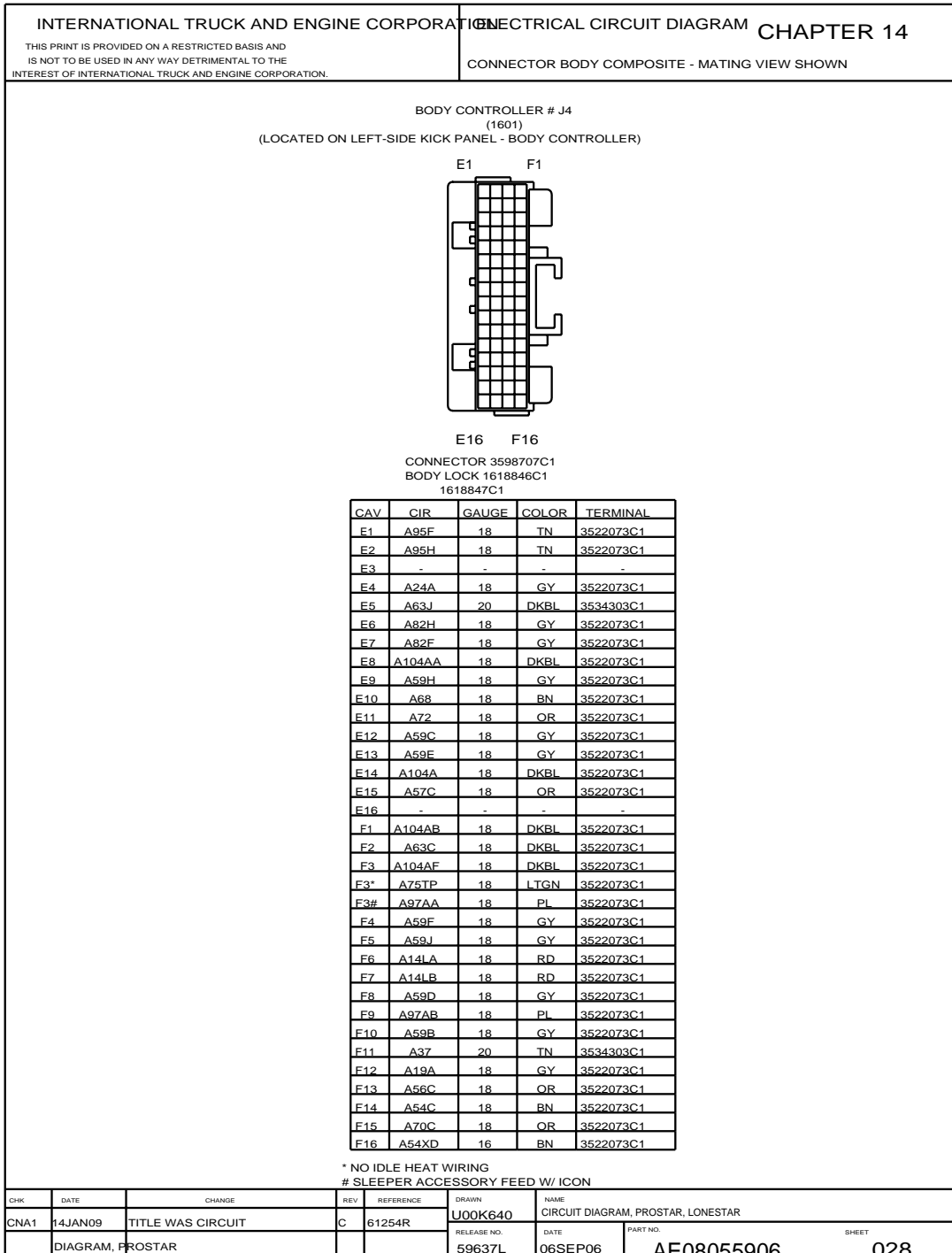


Figure 262 Connector Composite (1601)

14.34. CONNECTOR COMPOSITE (1602), P. 29

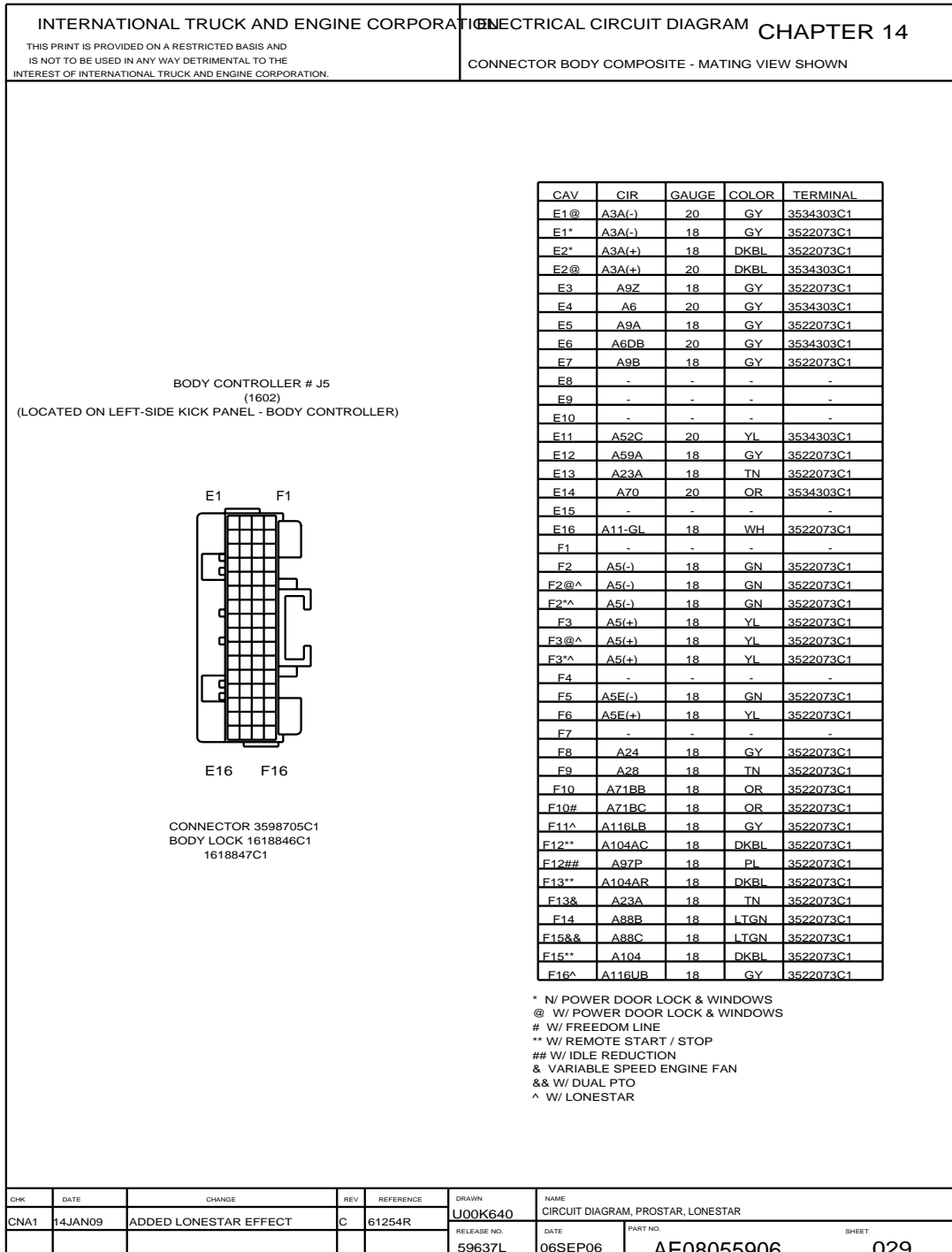


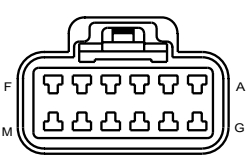
Figure 263 Connector Composite (1602)

14.35. CONNECTOR COMPOSITES (1603), (1604), P. 30

INTERNATIONAL TRUCK AND ENGINE CORPORATION		ELECTRICAL CIRCUIT DIAGRAM CHAPTER 14	
THIS PRINT IS PROVIDED ON A RESTRICTED BASIS AND IS NOT TO BE USED IN ANY WAY DETRIMENTAL TO THE INTEREST OF INTERNATIONAL TRUCK AND ENGINE CORPORATION.		CONNECTOR BODY COMPOSITE - MATING VIEW SHOWN	

BODY CONTROLLER # J1  
(1603)  
(LOCATED ON LEFT - SIDE TRIM KICK PANEL - BODY CONTROLLER)




CONNECTOR 3598711C1

CAV	CIR	GAUGE	COLOR	TERMINAL
A@	A57	16	OR	3544876C1
A*	A57N	16	OR	3544876C1
B@	A56	16	OR	3544876C1
B*	A56N	16	OR	3544876C1
C	A77	18	LTGN	3544876C1
D	A56A	14	OR	3544877C1
E	A85	16	GY	3544876C1
F	A64A	16	YL	3544876C1
G	A65	18	OR	3544876C1
G#	A65AA	16	OR	3544876C1
H	A78A	16	LTGN	3544876C1
J	-	-	-	-
K	A64B	16	YL	3544876C1
L	A78B	16	LTGN	3544876C1
M	A57A	14	OR	3544877C1

@ N/ COLLISION WARNING  
\* W/ MIRROR MTD TURN  
# W/ CUSTOMER SUPPLIED LIGHT

BODY CONTROLLER # J2  
(1604)  
(LOCATED ON LEFT-SIDE TRIM KICK PANEL - BODY CONTROLLER)



CONNECTOR 3598707C1  
& 3598710C1

CAV	CIR	GAUGE	COLOR	TERMINAL
A	A82	16	GY	3544876C1
B@	A53AA	14	YL	3544877C1
B*	A53A	14	YL	3544877C1
C@	A52AA	14	YL	3544877C1
C*	A52A	14	YL	3544877C1
D	-	-	-	-
E	A11-GKC	12	WH	3544877C1
F#	A58C	16	BN	3544876C1
F##	A58C	18	BN	3544876C1
G@	A54	16	BN	3544876C1
G*&	A54	16	BN	3544876C1
H@	A53B	14	YL	3544877C1
H*&	A53B	14	YL	3544877C1
J	A63	18	DKBL	3544876C1
K@	A52B	14	YL	3544877C1
K*&	A52B	14	YL	3544877C1

@ W/ TRIP MASTER  
\* N/ TRIP MASTER  
# W/ DAY CAB AIR SHIELD  
## W/ SLEEPER CAB AIR SHIELD  
& W/ LONESTAR

CHK	DATE	CHANGE	REV	REFERENCE	DRAWN	NAME
CNA1	14JAN09	ADDED LONESTAR EFFECT	B	61254R	U00K640	CIRCUIT DIAGRAM, PROSTAR, LONESTAR
					RELEASE NO.	DATE
					59637L	06SEP06
						PART NO.
						AE08055906
						SHEET
						030

Figure 264 Connector Composites (1603), (1604)

14.36. CONNECTOR COMPOSITES (1620), (1650), (1657), (1657M), P. 31

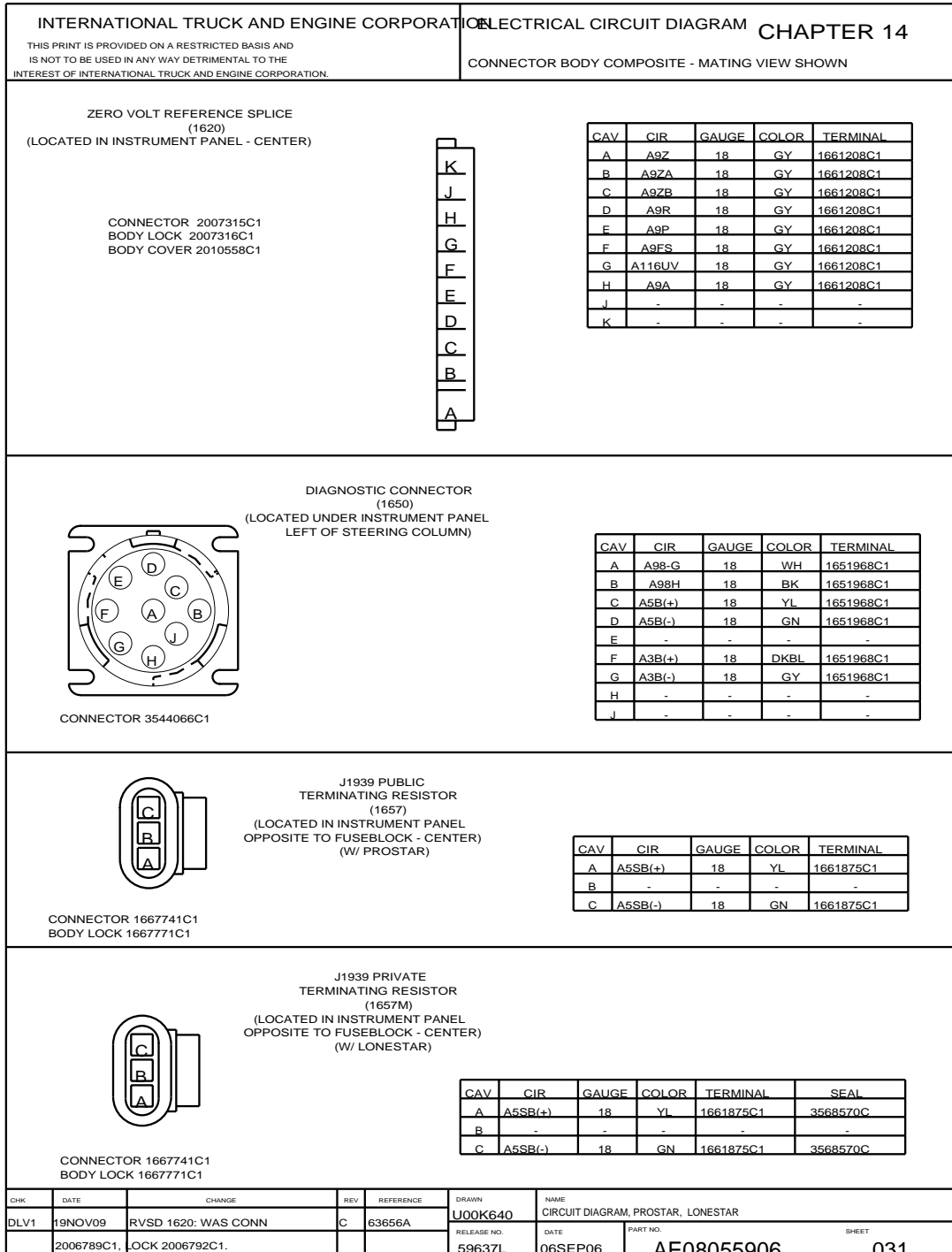


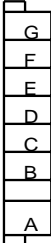
Figure 265 Connector Composites (1620), (1650), (1657), (1657M)

14.37. CONNECTOR COMPOSITES (1660), (1661), P. 32

<p>INTERNATIONAL TRUCK AND ENGINE CORPORATION</p> <p>THIS PRINT IS PROVIDED ON A RESTRICTED BASIS AND IS NOT TO BE USED IN ANY WAY DETRIMENTAL TO THE INTEREST OF INTERNATIONAL TRUCK AND ENGINE CORPORATION.</p>	<p>ELECTRICAL CIRCUIT DIAGRAM CHAPTER 14</p> <p>CONNECTOR BODY COMPOSITE - MATING VIEW SHOWN</p>
---	--

J1708 PUBLIC(+)  
CONNECTOR  
(1660)  
(LOCATED IN INSTRUMENT PANEL LEFT SIDE)



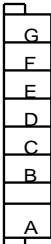
CAV	CIR	GAUGE	COLOR	TERMINAL
A	A3B(+)	18	DKBL	1661208C1
B*	A98A(+)	18	DKBL	1661208C1
B	A3BA(+)	18	DKBL	1661208C1
B**	A3BD(+)	18	DKBL	1661208C1
C	A3H(+)	18	DKBL	1661208C1
D#	A3BC(+)	18	DKBL	1661208C1
D##	A3BC(+)	20	DKBL	1661208C1
E@	A3BN(+)	18	DKBL	1661208C1
E	A3BD(+)	18	DKBL	1661208C1
F*	A3BE(+)	20	DKBL	1661208C1
F**	A3BD(+)	18	DKBL	1661208C1
G	A3BF(+)	20	DKBL	1661208C1

\* W/ DAY CAB  
\*\* W/ SLEEPER  
# W/ CAT ENGINE DISPLAY  
## W/ CUMMINS ENGINE DISPLAY  
@ W/ TELEMATICS

CONNECTOR 2006789C1  
BODY LOCK 2006792C1

---

J1708 PUBLIC(-)  
CONNECTOR  
(1661)  
(LOCATED IN INSTRUMENT PANEL LEFT SIDE)



CAV	CIR	GAUGE	COLOR	TERMINAL
A	A3B(-)	18	GY	1661208C1
B*	A98B(-)	18	GY	1661208C1
B	A3BA(-)	18	GY	1661208C1
B**	A98BD(-)	18	GY	1661208C1
C	A3H(-)	18	GY	1661208C1
D#	A3BC(-)	18	GY	1661208C1
D##	A3BC(-)	20	GY	1661208C1
E@	A3BN(-)	18	GY	1661208C1
E	A3BD(-)	18	GY	1661208C1
F**	A3BD(-)	18	GY	1661208C1
F*	A3BE(-)	20	GY	1661208C1
G	A3BF(-)	20	GY	1661208C1

\* W/ DAY CAB  
\*\* W/ SLEEPER  
# W/ CAT ENGINE DISPLAY  
## W/ CUMMINS ENGINE DISPLAY  
@ W/ TELEMATICS

CONNECTOR 2006789C1  
BODY LOCK 2006792C1

CHK	DATE	CHANGE	REV	REFERENCE	DRAWN	NAME
CNA1	14JAN09	TITLE WAS CIRCUIT	A	61254R	U00K640	CIRCUIT DIAGRAM, PROSTAR, LONESTAR
		DIAGRAM, PROSTAR			59637L	06SEP06
						AE08055906
						032

Figure 266 Connector Composites (1660), (1661)

14.38. CONNECTOR COMPOSITE (1700), P. 33

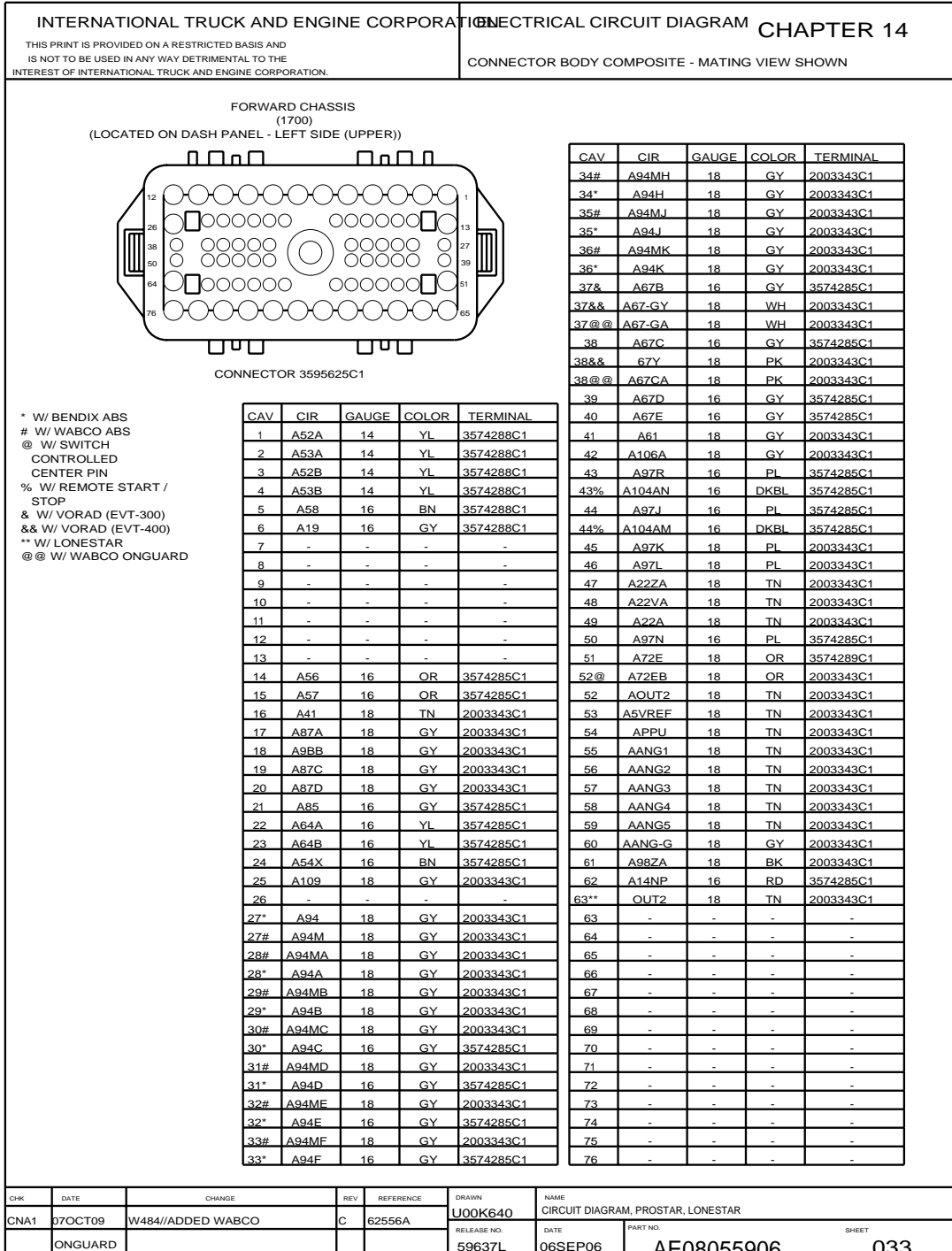


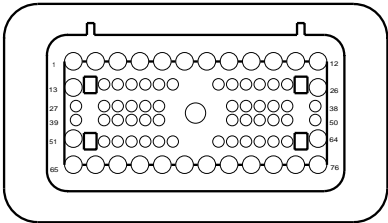
Figure 267 Connector Composite (1700)

14.39. CONNECTOR COMPOSITE (1700F), P. 34

<p>INTERNATIONAL TRUCK AND ENGINE CORPORATION</p> <p>THIS PRINT IS PROVIDED ON A RESTRICTED BASIS AND IS NOT TO BE USED IN ANY WAY DETRIMENTAL TO THE INTEREST OF INTERNATIONAL TRUCK AND ENGINE CORPORATION.</p>	<p>ELECTRICAL CIRCUIT DIAGRAM CHAPTER 14</p> <p>CONNECTOR BODY COMPOSITE - MATING VIEW SHOWN</p>
---	--

FORWARD CHASSIS CONNECTOR  
(1700F)  
(LOCATED ON FRONT LEFT DASH PANEL (UPPER))



CONNECTOR 3595624C1

CAV	CIR	GAUGE	COLOR	TERMINAL
1	M52A	14	YL	3549416C1
2	M53A	14	YL	3549416C1
3	M52B	14	YL	3549416C1
4	M53B	14	YL	3549416C1
5	M58	14	BN	3549416C1
6	M19	14	GY	3549416C1
7	PLUG	-	-	3598921C1
8	PLUG	-	-	3598921C1
9	PLUG	-	-	3598921C1
10	PLUG	-	-	3598921C1
11	PLUG	-	-	3598921C1
12	PLUG	-	-	3598921C1
13	PLUG	-	-	3598921C1
14	M56	16	OR	3549417C1
15	M57	16	OR	3549417C1
16	M41	18	GY	3549418C1
17	M87A	18	GY	3549418C1
18	M9BB	18	GY	3549418C1
19	M87C	16	GY	3549417C1
20	M87D	16	GY	3549417C1
21	M85	16	GY	3549417C1
22	M64A	16	YL	3549417C1
23	M64B	16	YL	3549417C1
24	M54X	16	OR	3549417C1
25	M109A	18	GY	3549418C1
26	PLUG	-	-	3598921C1
27*	M94	18	GY	3549418C1
27#	M94M	18	GY	3549418C1
28*	M94A	18	GY	3549418C1
28#	M94MA	18	GY	3549418C1
29*	M94B	18	GY	3549418C1
29#	M94MB	18	GY	3549418C1
30*	M94C	18	GY	3549418C1
30#	M94MC	18	GY	3549418C1

\* W/ BENDIX ABS  
# W/ WABCO ABS  
@ W/ REMOTE START STOP  
@@ W/ CUMMINS ICON  
% W/ VORAD VS-400  
%% W/ WABCO ONGUARD

CAV	CIR	GAUGE	COLOR	TERMINAL
31*	M94D	18	GY	3549418C1
31#	M94MD	18	GY	3549418C1
32*	M94E	18	GY	3549418C1
32#	M94ME	18	GY	3549418C1
33*	M94F	18	GY	3549418C1
33#	M94MF	18	GY	3549418C1
34*	M94H	18	GY	3549418C1
34#	M94MH	18	GY	3549418C1
35*	M94J	18	GY	3549418C1
35#	M94MJ	18	GY	3549418C1
36*	M94K	18	GY	3549418C1
36#	M94MK	18	GY	3549418C1
37	M67B	16	GY	3549417C1
37%	M67-GY	18	WH	3549418C1
37%%	M67-GA	20	WH	3549418C1
38	M67C	16	GY	3549417C1
38%	M67Y	18	PK	3549418C1
38%%	M67CA	20	PK	3549418C1
39	M67D	16	GY	3549417C1
40	M67E	16	GY	3549417C1
41	M61	18	GY	3549418C1
42	M106A	18	GY	3549418C1
43@	M97H	18	VT	3549418C1
43@@	M97R	18	VT	3549418C1
44	M97J	18	VT	3549418C1
45	M97K	18	VT	3549418C1
46	M97L	18	VT	3549418C1
47	M22ZA	20	TN	3549418C1
48	M22VA	20	TN	3549418C1
49	M22A	20	TN	3549418C1
50	M97N	18	VT	3549418C1
51	M72EA	16	OR	3549416C1
52	M72EB	16	OR	3549417C1
53	PLUG	-	-	3598921C1
54	PLUG	-	-	3598921C1
55	PLUG	-	-	3598921C1
56	PLUG	-	-	3598921C1
57	PLUG	-	-	3598921C1
58	PLUG	-	-	3598921C1
59	PLUG	-	-	3598921C1
60	PLUG	-	-	3598921C1
61	PLUG	-	-	3598921C1
62	PLUG	-	-	3598921C1
63	PLUG	-	-	3598921C1
64	PLUG	-	-	3598921C1
65	PLUG	-	-	3598921C1
66	PLUG	-	-	3598921C1
67	PLUG	-	-	3598921C1
68	PLUG	-	-	3598921C1
69	PLUG	-	-	3598921C1
70	PLUG	-	-	3598921C1
71	PLUG	-	-	3598921C1
72	PLUG	-	-	3598921C1
73	PLUG	-	-	3598921C1
74	PLUG	-	-	3598921C1
75	PLUG	-	-	3598921C1

CHK	DATE	CHANGE	REV	REFERENCE	DRAWN	NAME
CNA1	07OCT09	W484/ADDED WABCO	C	62556A	U00K640	CIRCUIT DIAGRAM, PROSTAR, LONESTAR
	ONGUARD				RELEASE NO. 59637L	DATE 06SEP06 PART NO. AE08055906 SHEET 034

Figure 268 Connector Composite (1700F)

14.40. CONNECTOR COMPOSITE (1701), P. 35

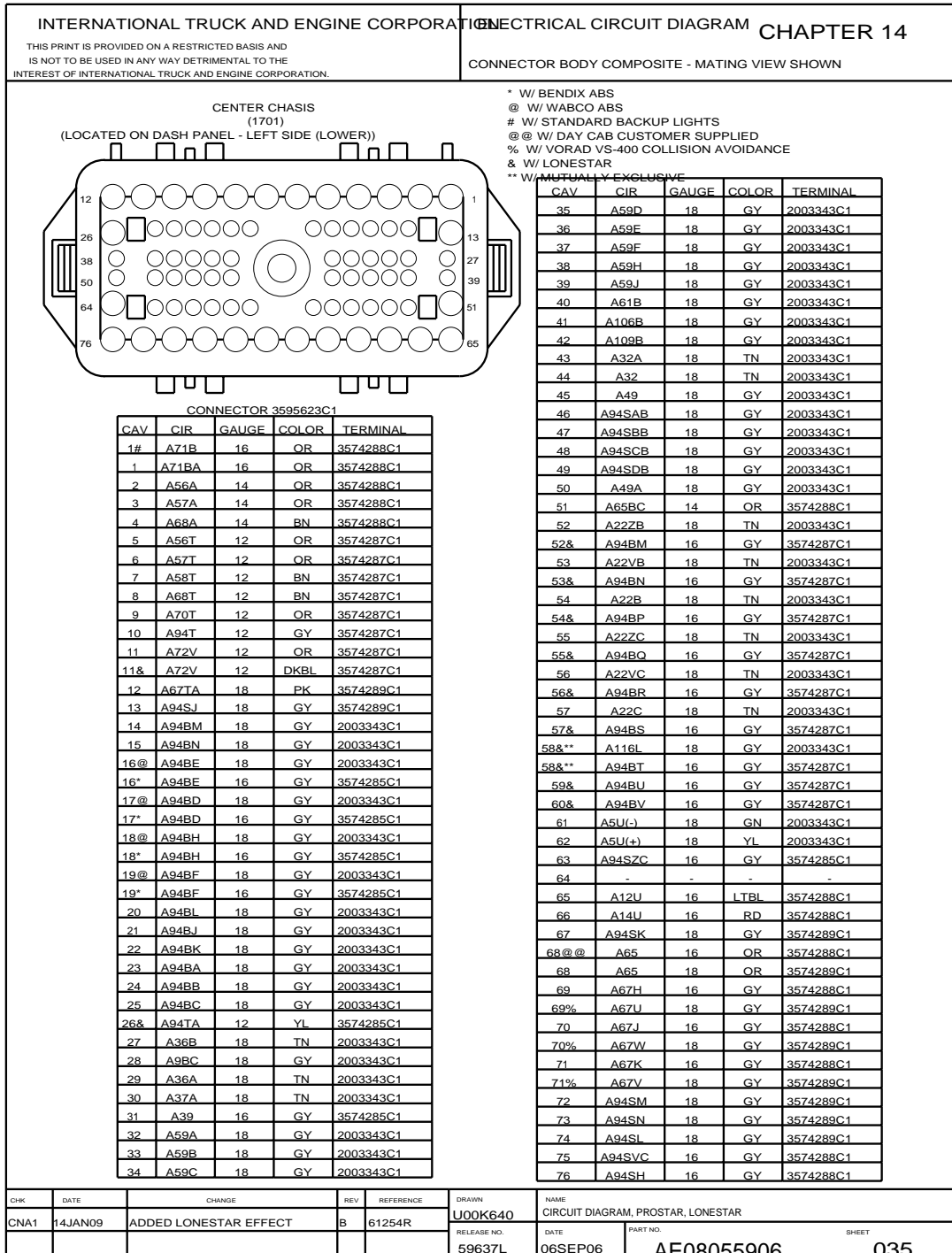
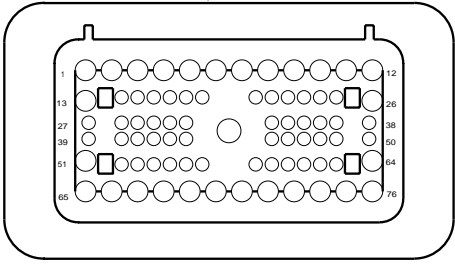


Figure 269 Connector Composite (1701)

14.41. CONNECTOR COMPOSITE (1701F), P. 36

INTERNATIONAL TRUCK AND ENGINE CORPORATION		ELECTRICAL CIRCUIT DIAGRAM		CHAPTER 14																																																																																																																																																																																																																																																																																									
THIS PRINT IS PROVIDED ON A RESTRICTED BASIS AND IS NOT TO BE USED IN ANY WAY DETRIMENTAL TO THE INTEREST OF INTERNATIONAL TRUCK AND ENGINE CORPORATION.		CONNECTOR BODY COMPOSITE - MATING VIEW SHOWN																																																																																																																																																																																																																																																																																											
CENTER CHASSIS CONNECTOR (1701F) (LOCATED ON FRONT LEFT DASH PANEL (LOWER))																																																																																																																																																																																																																																																																																													
			<table border="1" style="width:100%; border-collapse: collapse; font-size: x-small;"> <tr><td>35</td><td>N59D</td><td>18</td><td>GY</td><td>3549418C1</td></tr> <tr><td>35**</td><td>N59K</td><td>18</td><td>GY</td><td>3549418C1</td></tr> <tr><td>36</td><td>N59E</td><td>18</td><td>GY</td><td>3549418C1</td></tr> <tr><td>36**</td><td>N59K</td><td>16</td><td>GY</td><td>3549417C1</td></tr> <tr><td>37</td><td>N59F</td><td>18</td><td>GY</td><td>3549418C1</td></tr> <tr><td>37**</td><td>N59K</td><td>18</td><td>GY</td><td>3549418C1</td></tr> <tr><td>38</td><td>N59H</td><td>18</td><td>GY</td><td>3549418C1</td></tr> <tr><td>38**</td><td>N59K</td><td>16</td><td>GY</td><td>3549418C1</td></tr> <tr><td>39</td><td>N59J</td><td>18</td><td>GY</td><td>3549418C1</td></tr> <tr><td>40</td><td>N61B</td><td>18</td><td>GY</td><td>3549418C1</td></tr> <tr><td>41</td><td>N106B</td><td>18</td><td>GY</td><td>3549418C1</td></tr> <tr><td>42</td><td>N109B</td><td>18</td><td>GY</td><td>3549418C1</td></tr> <tr><td>43</td><td>N32A</td><td>18</td><td>TN</td><td>3549418C1</td></tr> <tr><td>44</td><td>N32</td><td>18</td><td>TN</td><td>3549418C1</td></tr> <tr><td>45</td><td>N49</td><td>18</td><td>GY</td><td>3549418C1</td></tr> <tr><td>46</td><td>N94SAB</td><td>18</td><td>GY</td><td>3549418C1</td></tr> <tr><td>47</td><td>N94SBB</td><td>18</td><td>GY</td><td>3549418C1</td></tr> <tr><td>48</td><td>N94SCB</td><td>18</td><td>GY</td><td>3549418C1</td></tr> <tr><td>49</td><td>N94SDB</td><td>18</td><td>GY</td><td>3549418C1</td></tr> <tr><td>50</td><td>N49A</td><td>18</td><td>GY</td><td>3549418C1</td></tr> <tr><td>51</td><td>N65BC</td><td>14</td><td>OR</td><td>3549416C1</td></tr> <tr><td>52</td><td>N22ZB</td><td>18</td><td>TN</td><td>3549418C1</td></tr> <tr><td>52&amp;@</td><td>N94BM</td><td>16</td><td>GY</td><td>3549417C1</td></tr> <tr><td>53</td><td>N22VB</td><td>18</td><td>TN</td><td>3549418C1</td></tr> <tr><td>53&amp;@</td><td>N94BN</td><td>16</td><td>GY</td><td>3549417C1</td></tr> <tr><td>54</td><td>N22B</td><td>18</td><td>TN</td><td>3549418C1</td></tr> <tr><td>54&amp;@</td><td>N94BP</td><td>16</td><td>GY</td><td>3549417C1</td></tr> <tr><td>55</td><td>N22ZC</td><td>18</td><td>TN</td><td>3549418C1</td></tr> <tr><td>55&amp;@</td><td>N94BQ</td><td>16</td><td>GY</td><td>3549417C1</td></tr> <tr><td>56</td><td>N22VC</td><td>18</td><td>TN</td><td>3549418C1</td></tr> <tr><td>56&amp;@</td><td>N94BR</td><td>16</td><td>GY</td><td>3549417C1</td></tr> <tr><td>57</td><td>N22C</td><td>18</td><td>TN</td><td>3549418C1</td></tr> <tr><td>57&amp;@</td><td>N94BS</td><td>16</td><td>GY</td><td>3549417C1</td></tr> <tr><td>58</td><td>-</td><td>-</td><td>-</td><td>-</td></tr> <tr><td>59</td><td>-</td><td>-</td><td>-</td><td>-</td></tr> <tr><td>60</td><td>-</td><td>-</td><td>-</td><td>-</td></tr> <tr><td>61</td><td>N5U(-)</td><td>18</td><td>GN</td><td>3549418C1</td></tr> <tr><td>62</td><td>N5U(+)</td><td>18</td><td>YL</td><td>3549418C1</td></tr> <tr><td>63</td><td>N94SZC</td><td>16</td><td>GY</td><td>3549417C1</td></tr> <tr><td>64</td><td>-</td><td>-</td><td>-</td><td>-</td></tr> <tr><td>65</td><td>N12UA</td><td>16</td><td>PK</td><td>3549416C1</td></tr> <tr><td>65</td><td>N12U</td><td>16</td><td>PK</td><td>3549416C1</td></tr> <tr><td>66</td><td>N14U</td><td>16</td><td>RD</td><td>3549416C1</td></tr> <tr><td>67</td><td>N94SK</td><td>16</td><td>GY</td><td>3549416C1</td></tr> <tr><td>68</td><td>N65</td><td>16</td><td>OR</td><td>3549416C1</td></tr> <tr><td>69</td><td>N67H</td><td>16</td><td>GY</td><td>3549416C1</td></tr> <tr><td>69*</td><td>N67U</td><td>16</td><td>GY</td><td>3549416C1</td></tr> <tr><td>70</td><td>N67J</td><td>16</td><td>GY</td><td>3549416C1</td></tr> <tr><td>70*</td><td>N67W</td><td>16</td><td>GY</td><td>3549416C1</td></tr> <tr><td>71</td><td>N67K</td><td>16</td><td>GY</td><td>3549416C1</td></tr> <tr><td>71*</td><td>N67V</td><td>16</td><td>GY</td><td>3549416C1</td></tr> <tr><td>72</td><td>N94SM</td><td>16</td><td>GY</td><td>3549416C1</td></tr> <tr><td>73</td><td>N94SN</td><td>16</td><td>GY</td><td>3549416C1</td></tr> <tr><td>74</td><td>N94SL</td><td>16</td><td>GY</td><td>3549416C1</td></tr> <tr><td>75</td><td>N94SVC</td><td>16</td><td>GY</td><td>3549416C1</td></tr> <tr><td>76</td><td>N94SH</td><td>16</td><td>GY</td><td>3549416C1</td></tr> </table>			35	N59D	18	GY	3549418C1	35**	N59K	18	GY	3549418C1	36	N59E	18	GY	3549418C1	36**	N59K	16	GY	3549417C1	37	N59F	18	GY	3549418C1	37**	N59K	18	GY	3549418C1	38	N59H	18	GY	3549418C1	38**	N59K	16	GY	3549418C1	39	N59J	18	GY	3549418C1	40	N61B	18	GY	3549418C1	41	N106B	18	GY	3549418C1	42	N109B	18	GY	3549418C1	43	N32A	18	TN	3549418C1	44	N32	18	TN	3549418C1	45	N49	18	GY	3549418C1	46	N94SAB	18	GY	3549418C1	47	N94SBB	18	GY	3549418C1	48	N94SCB	18	GY	3549418C1	49	N94SDB	18	GY	3549418C1	50	N49A	18	GY	3549418C1	51	N65BC	14	OR	3549416C1	52	N22ZB	18	TN	3549418C1	52&@	N94BM	16	GY	3549417C1	53	N22VB	18	TN	3549418C1	53&@	N94BN	16	GY	3549417C1	54	N22B	18	TN	3549418C1	54&@	N94BP	16	GY	3549417C1	55	N22ZC	18	TN	3549418C1	55&@	N94BQ	16	GY	3549417C1	56	N22VC	18	TN	3549418C1	56&@	N94BR	16	GY	3549417C1	57	N22C	18	TN	3549418C1	57&@	N94BS	16	GY	3549417C1	58	-	-	-	-	59	-	-	-	-	60	-	-	-	-	61	N5U(-)	18	GN	3549418C1	62	N5U(+)	18	YL	3549418C1	63	N94SZC	16	GY	3549417C1	64	-	-	-	-	65	N12UA	16	PK	3549416C1	65	N12U	16	PK	3549416C1	66	N14U	16	RD	3549416C1	67	N94SK	16	GY	3549416C1	68	N65	16	OR	3549416C1	69	N67H	16	GY	3549416C1	69*	N67U	16	GY	3549416C1	70	N67J	16	GY	3549416C1	70*	N67W	16	GY	3549416C1	71	N67K	16	GY	3549416C1	71*	N67V	16	GY	3549416C1	72	N94SM	16	GY	3549416C1	73	N94SN	16	GY	3549416C1	74	N94SL	16	GY	3549416C1	75	N94SVC	16	GY	3549416C1	76	N94SH	16	GY	3549416C1
35	N59D	18	GY	3549418C1																																																																																																																																																																																																																																																																																									
35**	N59K	18	GY	3549418C1																																																																																																																																																																																																																																																																																									
36	N59E	18	GY	3549418C1																																																																																																																																																																																																																																																																																									
36**	N59K	16	GY	3549417C1																																																																																																																																																																																																																																																																																									
37	N59F	18	GY	3549418C1																																																																																																																																																																																																																																																																																									
37**	N59K	18	GY	3549418C1																																																																																																																																																																																																																																																																																									
38	N59H	18	GY	3549418C1																																																																																																																																																																																																																																																																																									
38**	N59K	16	GY	3549418C1																																																																																																																																																																																																																																																																																									
39	N59J	18	GY	3549418C1																																																																																																																																																																																																																																																																																									
40	N61B	18	GY	3549418C1																																																																																																																																																																																																																																																																																									
41	N106B	18	GY	3549418C1																																																																																																																																																																																																																																																																																									
42	N109B	18	GY	3549418C1																																																																																																																																																																																																																																																																																									
43	N32A	18	TN	3549418C1																																																																																																																																																																																																																																																																																									
44	N32	18	TN	3549418C1																																																																																																																																																																																																																																																																																									
45	N49	18	GY	3549418C1																																																																																																																																																																																																																																																																																									
46	N94SAB	18	GY	3549418C1																																																																																																																																																																																																																																																																																									
47	N94SBB	18	GY	3549418C1																																																																																																																																																																																																																																																																																									
48	N94SCB	18	GY	3549418C1																																																																																																																																																																																																																																																																																									
49	N94SDB	18	GY	3549418C1																																																																																																																																																																																																																																																																																									
50	N49A	18	GY	3549418C1																																																																																																																																																																																																																																																																																									
51	N65BC	14	OR	3549416C1																																																																																																																																																																																																																																																																																									
52	N22ZB	18	TN	3549418C1																																																																																																																																																																																																																																																																																									
52&@	N94BM	16	GY	3549417C1																																																																																																																																																																																																																																																																																									
53	N22VB	18	TN	3549418C1																																																																																																																																																																																																																																																																																									
53&@	N94BN	16	GY	3549417C1																																																																																																																																																																																																																																																																																									
54	N22B	18	TN	3549418C1																																																																																																																																																																																																																																																																																									
54&@	N94BP	16	GY	3549417C1																																																																																																																																																																																																																																																																																									
55	N22ZC	18	TN	3549418C1																																																																																																																																																																																																																																																																																									
55&@	N94BQ	16	GY	3549417C1																																																																																																																																																																																																																																																																																									
56	N22VC	18	TN	3549418C1																																																																																																																																																																																																																																																																																									
56&@	N94BR	16	GY	3549417C1																																																																																																																																																																																																																																																																																									
57	N22C	18	TN	3549418C1																																																																																																																																																																																																																																																																																									
57&@	N94BS	16	GY	3549417C1																																																																																																																																																																																																																																																																																									
58	-	-	-	-																																																																																																																																																																																																																																																																																									
59	-	-	-	-																																																																																																																																																																																																																																																																																									
60	-	-	-	-																																																																																																																																																																																																																																																																																									
61	N5U(-)	18	GN	3549418C1																																																																																																																																																																																																																																																																																									
62	N5U(+)	18	YL	3549418C1																																																																																																																																																																																																																																																																																									
63	N94SZC	16	GY	3549417C1																																																																																																																																																																																																																																																																																									
64	-	-	-	-																																																																																																																																																																																																																																																																																									
65	N12UA	16	PK	3549416C1																																																																																																																																																																																																																																																																																									
65	N12U	16	PK	3549416C1																																																																																																																																																																																																																																																																																									
66	N14U	16	RD	3549416C1																																																																																																																																																																																																																																																																																									
67	N94SK	16	GY	3549416C1																																																																																																																																																																																																																																																																																									
68	N65	16	OR	3549416C1																																																																																																																																																																																																																																																																																									
69	N67H	16	GY	3549416C1																																																																																																																																																																																																																																																																																									
69*	N67U	16	GY	3549416C1																																																																																																																																																																																																																																																																																									
70	N67J	16	GY	3549416C1																																																																																																																																																																																																																																																																																									
70*	N67W	16	GY	3549416C1																																																																																																																																																																																																																																																																																									
71	N67K	16	GY	3549416C1																																																																																																																																																																																																																																																																																									
71*	N67V	16	GY	3549416C1																																																																																																																																																																																																																																																																																									
72	N94SM	16	GY	3549416C1																																																																																																																																																																																																																																																																																									
73	N94SN	16	GY	3549416C1																																																																																																																																																																																																																																																																																									
74	N94SL	16	GY	3549416C1																																																																																																																																																																																																																																																																																									
75	N94SVC	16	GY	3549416C1																																																																																																																																																																																																																																																																																									
76	N94SH	16	GY	3549416C1																																																																																																																																																																																																																																																																																									
CONNECTOR 3595622C1																																																																																																																																																																																																																																																																																													
CAV	CIR	GAUGE	COLOR	TERMINAL																																																																																																																																																																																																																																																																																									
1	N71BA	14	OR	3549416C1																																																																																																																																																																																																																																																																																									
2	N56A	14	OR	3549416C1																																																																																																																																																																																																																																																																																									
3	N57A	14	OR	3549416C1																																																																																																																																																																																																																																																																																									
4	N68A	14	BN	3549416C1																																																																																																																																																																																																																																																																																									
5	N56T	10	YL	3549415C1																																																																																																																																																																																																																																																																																									
6	N57T	10	LTGN	3549415C1																																																																																																																																																																																																																																																																																									
7	N58T	10	BK	3549415C1																																																																																																																																																																																																																																																																																									
8	N68T	10	BN	3549415C1																																																																																																																																																																																																																																																																																									
9	N70T	10	RD	3549415C1																																																																																																																																																																																																																																																																																									
10	N94T	10	DKBL	3549415C1																																																																																																																																																																																																																																																																																									
11	N72V	12	DKBL	3549415C1																																																																																																																																																																																																																																																																																									
11##@	N72V	10	DKBL	3549415C1																																																																																																																																																																																																																																																																																									
12	N67TA	18	PK	3574289C1																																																																																																																																																																																																																																																																																									
12@	N67TA	16	PK	3549416C1																																																																																																																																																																																																																																																																																									
13	N94SJ	16	GY	3549416C1																																																																																																																																																																																																																																																																																									
14	N94BM	16	GY	3549417C1																																																																																																																																																																																																																																																																																									
15	N94BN	16	GY	3549417C1																																																																																																																																																																																																																																																																																									
16	N94BE	16	GY	3549417C1																																																																																																																																																																																																																																																																																									
17	N94BD	16	GY	3549417C1																																																																																																																																																																																																																																																																																									
18	N94BH	16	GY	3549417C1																																																																																																																																																																																																																																																																																									
19	N94BF	16	GY	3549417C1																																																																																																																																																																																																																																																																																									
20	N94BL	16	GY	3549417C1																																																																																																																																																																																																																																																																																									
21	N94BJ	16	GY	3549417C1																																																																																																																																																																																																																																																																																									
22	N94BK	16	GY	3549417C1																																																																																																																																																																																																																																																																																									
23	N94BA	16	GY	3549417C1																																																																																																																																																																																																																																																																																									
24	N94BB	16	GY	3549417C1																																																																																																																																																																																																																																																																																									
25	N94BC	16	GY	3549417C1																																																																																																																																																																																																																																																																																									
26##@	N94TA	12	YL	3549415C1																																																																																																																																																																																																																																																																																									
27	N36B	18	TN	3549418C1																																																																																																																																																																																																																																																																																									
27@	N36A	18	TN	3549418C1																																																																																																																																																																																																																																																																																									
28	N9BC	18	GY	3549418C1																																																																																																																																																																																																																																																																																									
29	N36A	18	TN	3549418C1																																																																																																																																																																																																																																																																																									
30	N37A	18	TN	3549418C1																																																																																																																																																																																																																																																																																									
31	N39	16	GY	3549417C1																																																																																																																																																																																																																																																																																									
32	N59A	18	GY	3549418C1																																																																																																																																																																																																																																																																																									
33	N59B	18	GY	3549418C1																																																																																																																																																																																																																																																																																									
34	N59C	18	GY	3549418C1																																																																																																																																																																																																																																																																																									
34**	N59K	16	GY	3549417C1																																																																																																																																																																																																																																																																																									

\*\* W/ VORAD VS-400   \* W/ 5TH WHEEL JAW LOCK SENSOR   ## W/ TRAILER SOCKET W/ ISO   & W/ BENDIX 6 CHANNEL ABS W/ ACT   && W/ NO FUEL FILTER SENSOR W/ VSM   @ W/ LONESTAR					
CHK	DATE	CHANGE	REV	REFERENCE	DRAWN
CNA1	14JAN09	ADDED LONESTAR EFFECT	B	61254R	U00K640
					NAME
					CIRCUIT DIAGRAM, PROSTAR, LONESTAR
					RELEASE NO.
					DATE
					06SEP06
					PART NO.
					AE08055906
					SHEET
					036

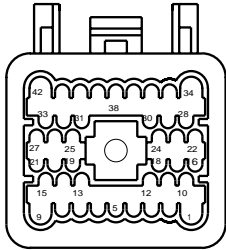
Figure 270 Connector Composite (1701F)

14.42. CONNECTOR COMPOSITE (1702), P. 37

INTERNATIONAL TRUCK AND ENGINE CORPORATION				ELECTRICAL CIRCUIT DIAGRAM		CHAPTER 14	
THIS PRINT IS PROVIDED ON A RESTRICTED BASIS AND IS NOT TO BE USED IN ANY WAY DETRIMENTAL TO THE INTEREST OF INTERNATIONAL TRUCK AND ENGINE CORPORATION.				CONNECTOR BODY COMPOSITE - MATING VIEW SHOWN			

IP CONNECTOR  
(1702)  
(LOCATED ON FRONT CENTER DASH PANEL)



CONNECTOR 3595621C1

\* MUTUALLY EXCLUSIVE  
# W/ STD BACKUP LIGHT  
## W/ WORK LIGHT FEED  
@ W/ CUMMINS ENGINE  
@@ W/ ENGINE OIL TEMPRATURE  
% W/ REMOTE START / STOP  
& W/ INTERNATIONAL ENGINE  
\*\* W/ LONESTAR

CAV	CIR	GAUGE	COLOR	TERMINAL
1*	A97D	10	RD	3574287C1
1*	A97D	10	PL	3574287C1
2	A9AA	20	GY	2003343C1
3	A6DB	20	GY	2003343C1
4	A77B	20	LTGN	2003343C1
5	A28	18	TN	2003343C1
6#	A71A	16	OR	3574285C1
6	A71-G	18	WH	2003343C1
6##	A71A	18	OR	2003343C1
7	A71B	16	OR	3574285C1
8	A13A	16	PK	3574285C1
9*	A14A	16	RD	3574288C1
9*	A14A	12	RD	3574287C1
10	A77	18	LTGN	2003343C1
11	A5R(+)	18	YL	2003343C1
12	A1	18	LTBL	2003343C1
13	A31	18	TN	2003343C1
14	A88	18	LTGN	2003343C1
15	A95	18	TN	2003343c1
16	A17	16	PK	3574285C1
17	A5R(-)	18	GN	2003343C1
18*	A23A	18	TN	3522073C1
18*	A97A1	18	PL	3515517C1
19*	A17-GC	16	WH	3574285C1
19*	A17-GC	18	WH	2003343C1
20	A17B	18	PK	2003343C1
21	A17C	18	PK	2003343C1
22	A97C	18	PL	2003343C1
23	A97B	18	PL	2003343C1
24@	A97M	18	PL	2003343C1
24@@	A30	16	TN	3574285C1
24&	A97F	16	PL	3595621C1
25	A92E	16	TN	3574285C1
26	A92F	18	TN	2003343C1
27	A92H	18	TN	2003343C1
28	A99B	18	PL	2003343C1
29	A97N	18	PL	2003343C1
30*	A99D	18	PL	2003343C1
30*	A97N	18	PL	2003343c1
31	PLUG	-	-	3508928C1
32	A97S	16	PL	3574285C1
32%	A104AL	16	DKBL	3574285C1
33%	A104AM	16	DKBL	3574285C1
33	A97J	16	PL	3574285C1
34	A97KB	14	PL	0382181C1
35	A3BA(+)	18	DKBL	2003343C1
36	A3BA(-)	18	GY	2003343C1
37	A97F	16	PL	3574285C1
37&	A97FB	16	PL	3574285C1
38	PLUG	-	-	3508928C1
39	A92A	18	TN	2003343C1
40	A92B	18	TN	2003343C1
41	A88A	18	LTGN	2003343C1
42	A97VT1	14	PL	3574288C1
42**	A97FZ	14	RD	3574288C1

CHK	DATE	CHANGE	REV	REFERENCE	DRAWN	NAME
CNA1	14JAN09	ADDED LONESTAR EFFECT	D	61254R	U00K640	CIRCUIT DIAGRAM, PROSTAR, LONESTAR
					RELEASE NO.	DATE
					59637L	06SEP06
						PART NO.
						AE08055906
						SHEET
						037

Figure 271 Connector Composite (1702)

14.43. CONNECTOR COMPOSITE (1702), P. 38

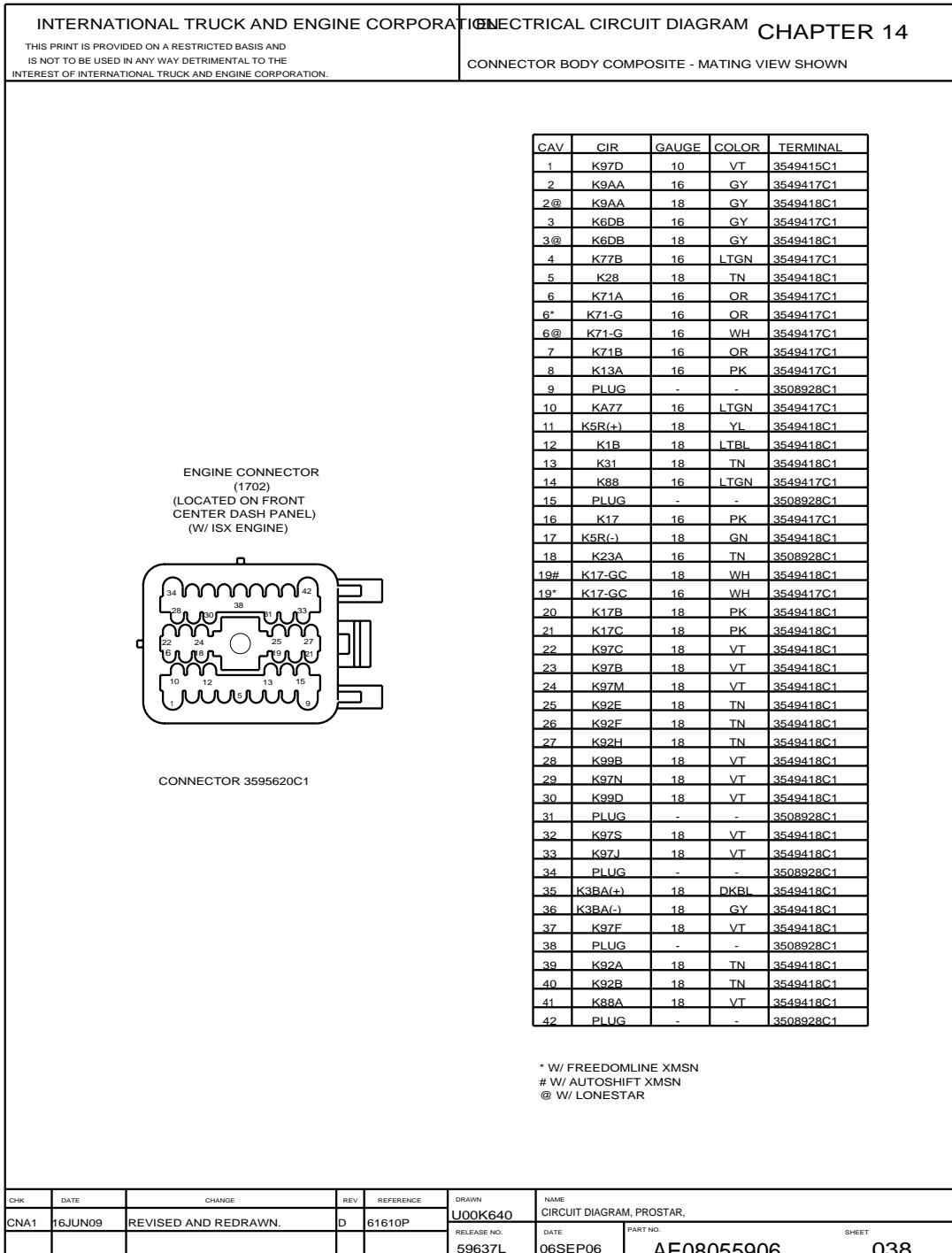


Figure 272 Connector Composite (1702)

14.44. CONNECTOR COMPOSITE (1702), P. 38A

<p>INTERNATIONAL TRUCK AND ENGINE CORPORATION</p> <p>THIS PRINT IS PROVIDED ON A RESTRICTED BASIS AND IS NOT TO BE USED IN ANY WAY DETRIMENTAL TO THE INTEREST OF INTERNATIONAL TRUCK AND ENGINE CORPORATION.</p>	<p>ELECTRICAL CIRCUIT DIAGRAM CHAPTER 14</p> <p>CONNECTOR BODY COMPOSITE - MATING VIEW SHOWN</p> <p>CAT ENGINE</p>
---	--

ENGINE CONNECTOR  
(1702)  
(LOCATED ON FRONT CENTER DASH PANEL  
(W/ CAT ENGINE))

CONNECTOR 3595620C1

CAV	CIR	GAUGE	COLOR	TERMINAL
1	PLUG	-	-	3508928C1
2*	K9AA	16	GY	3549417C1
2*	K9AA	18	GY	3549418C1
2	K30B	18	TN	3549418C1
3	K6DB	18	GY	3549418C1
4	K77B	18	LTGN	3549418C1
5	K28	18	TN	3549418C1
6*	K71A	16	OR	3549417C1
6*	K71-G	16	WH	3549417C1
7	K71B	16	OR	3549417C1
8	K13A	16	PK	3549417C1
	K13A	14	PK	3549417C1
9	PLUG	-	-	3508928C1
10	K77	16	LTGN	3549417C1
11	K5R(+)	18	YL	3549418C1
12	PLUG	-	-	3508928C1
13	K31H	18	TN	3549418C1
	K31	18	TN	3549418C1
14	K88	16	LTGN	3549417C1
15	PLUG	-	-	3508928C1
16	K17	16	PK	3549417C1
17	K5R(-)	18	GN	3549418C1
18	K23A	16	TN	3549417C1
19	K17-GC	16	WH	3549417C1
	K17-GC	18	WH	3549418C1
20	K17B	18	PK	3549418C1
21	K17C	18	PK	3549418C1
22	K97C	18	VT	3549418C1
23	K97B	18	VT	3549418C1
24	K30A	18	TN	3549418C1
25	K92E	18	TN	3549418C1
26	K92F	18	TN	3549418C1
27	K92H	18	TN	3549418C1
28	K99B	18	VT	3549418C1
29	PLUG	-	-	3508928C1
30	PLUG	-	-	3508928C1
31	PLUG	-	-	3508928C1
32	PLUG	-	-	3508928C1
33	PLUG	-	-	3508928C1
34	PLUG	-	-	3508928C1
35	K3BA(+)	18	YL	3549418C1
35	K3BA(+)	18	DKBL	3549418C1
36	K3BA(-)	18	GN	3549418C1
36	K3BA(-)	18	GY	3549418C1
37	K97F	18	VT	3549418C1
38	PLUG	-	-	3508928C1
39	K92A	18	TN	3549418C1
40	K92B	18	TN	3549418C1
41	K88A	18	TN	3549418C1
42	K97FZ	14	RD	3549416C1

\* MUTUALLY EXCLUSIVE

CHK	DATE	CHANGE	REV	REFERENCE	DRAWN	NAME
CNA1	14JAN09	TITLE WAS CIRCUIT	B	61254R	300523	CIRCUIT DIAGRAM, PROSTAR, LONESTAR
		DIAGRAM, PROSTAR			61406U	DATE: 15 JUN 08 PART NO: AE08055906 SHEET: 38A

Figure 273 Connector Composite (1702)

14.45. CONNECTOR COMPOSITE (1702), P. 38B

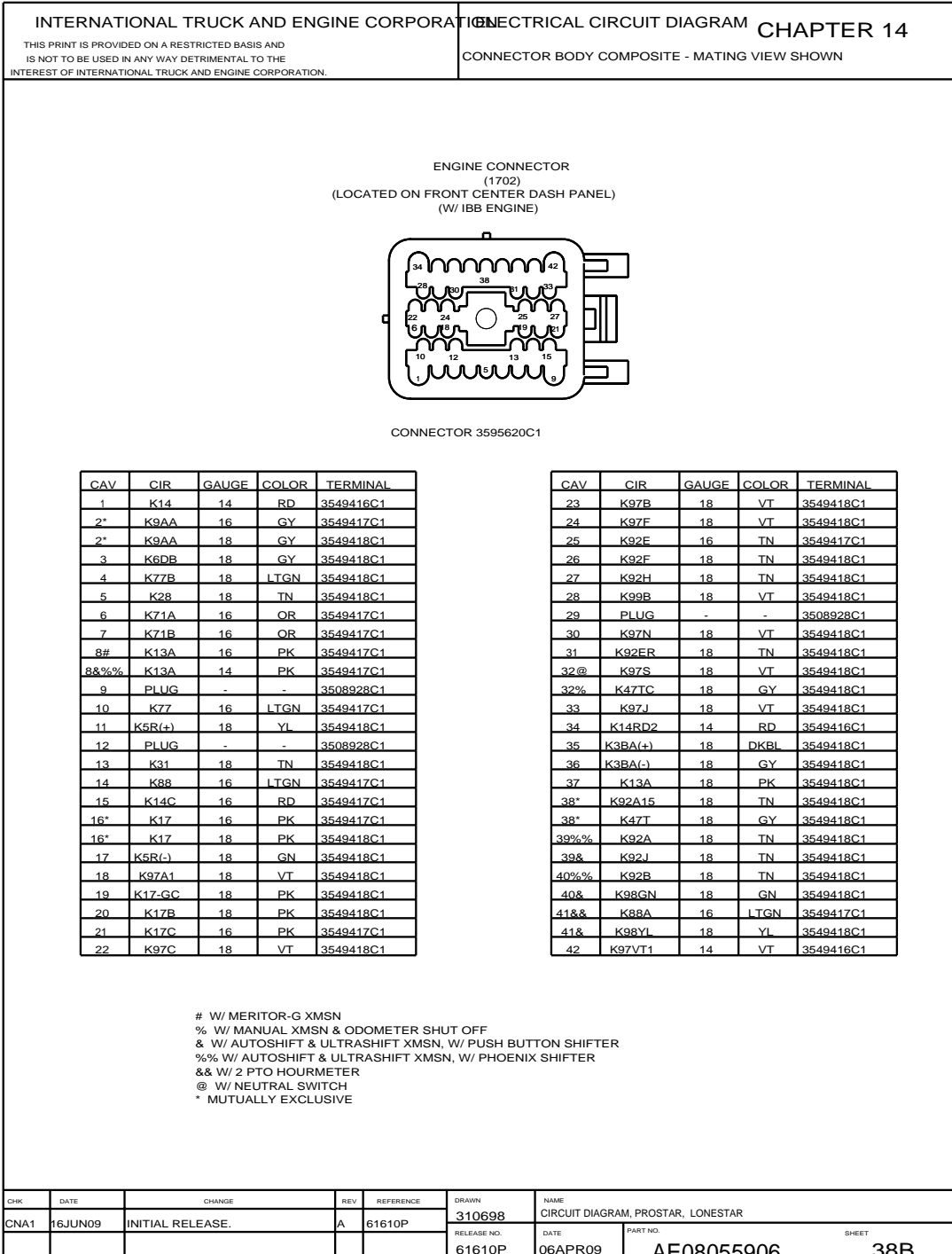


Figure 274 Connector Composite (1702)

14.46. CONNECTOR COMPOSITE (1800), P. 39

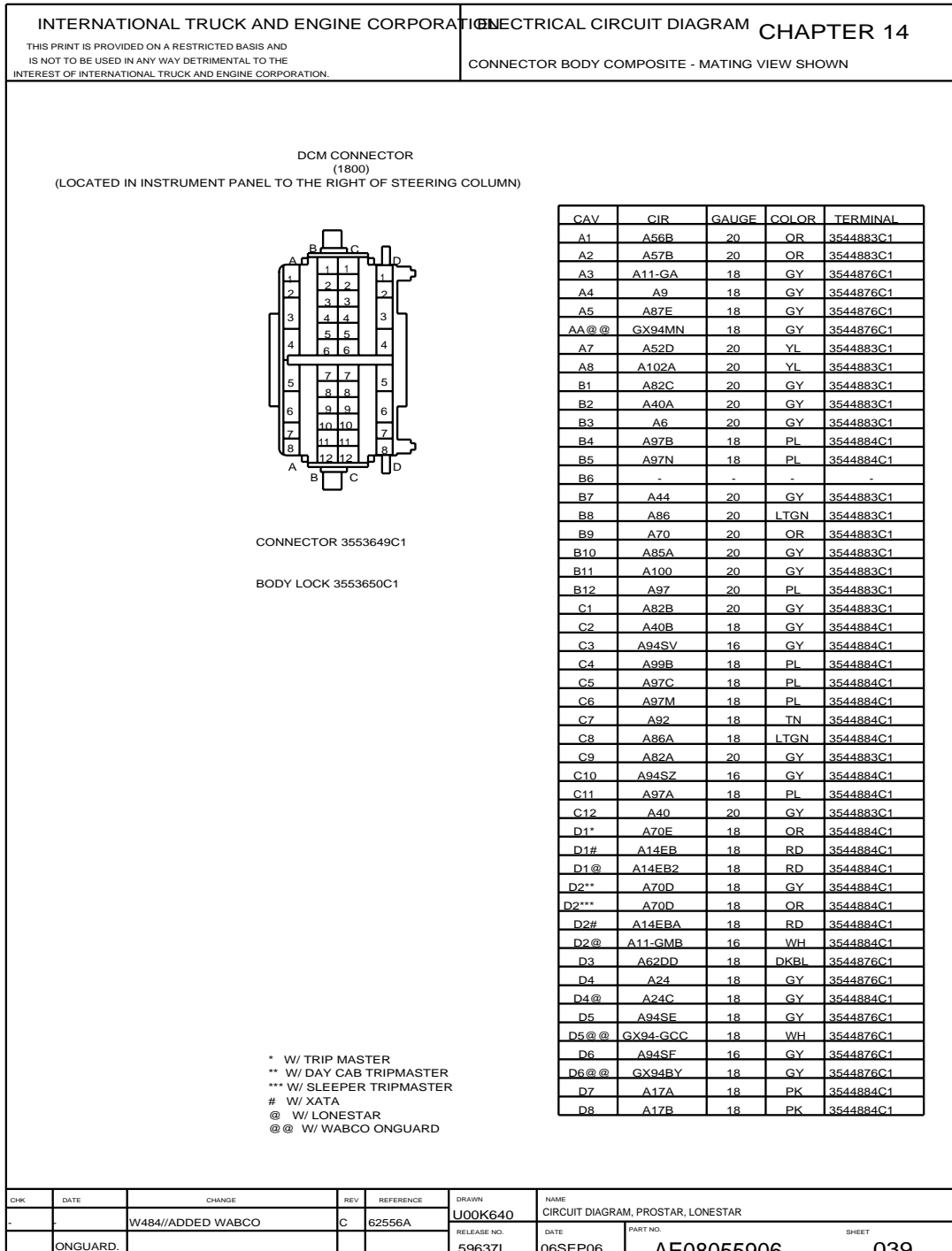


Figure 275 Connector Composite (1800)

14.47. CONNECTOR COMPOSITE (1800F), P. 40

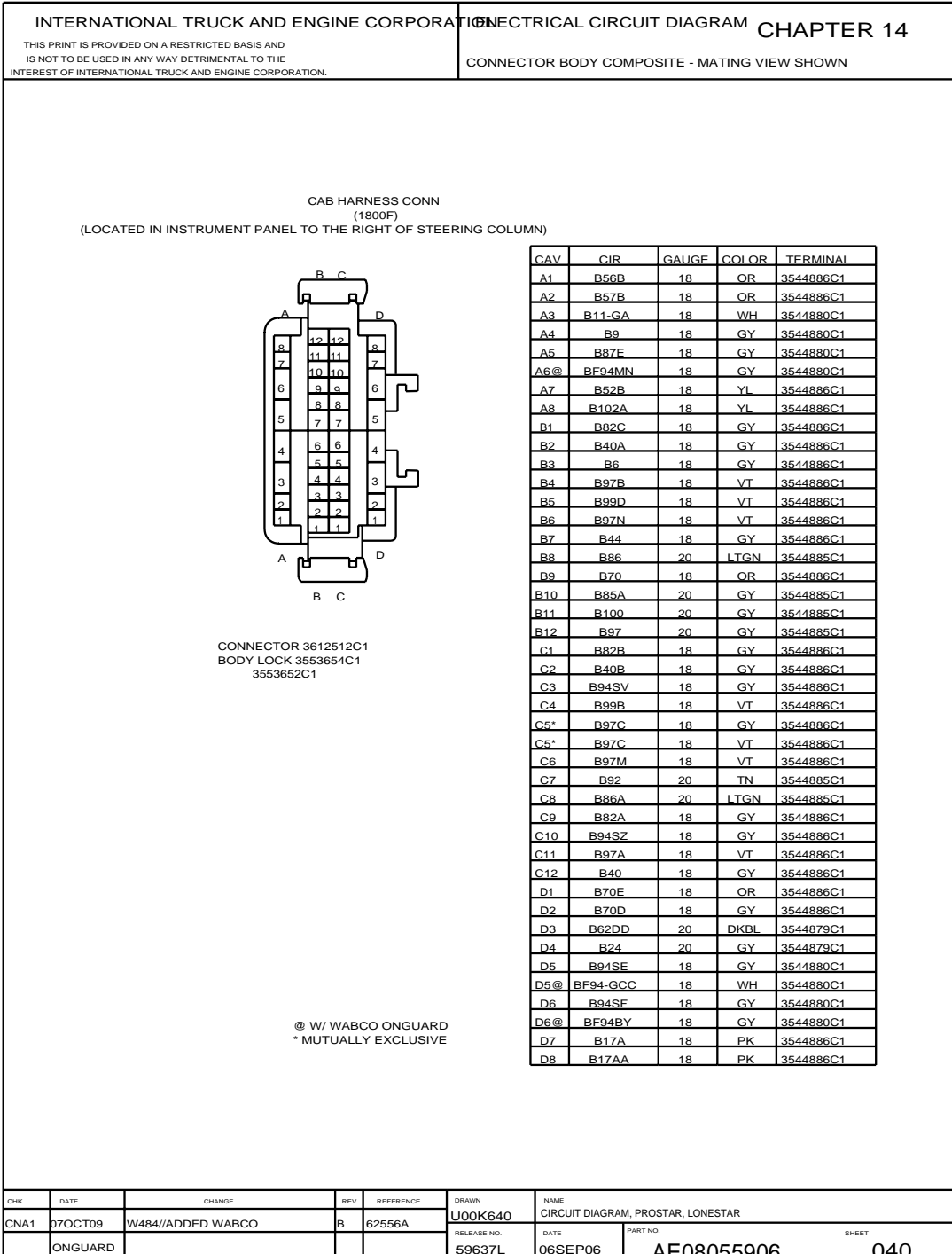


Figure 276 Connector Composite (1800F)

14.48. CONNECTOR COMPOSITES (1801), (1802), (1803), P. 41

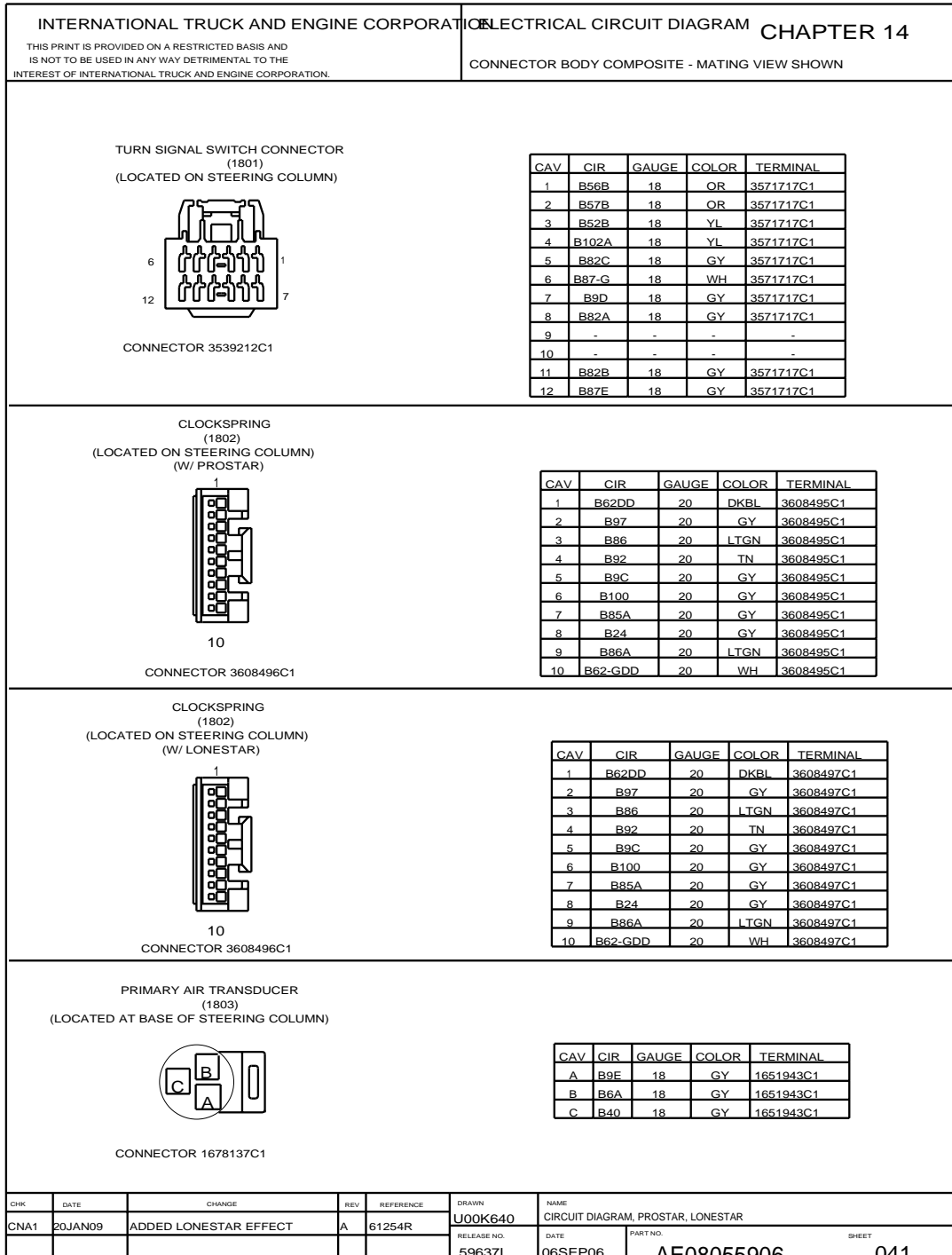


Figure 277 Connector Composites (1801), (1802), (1803)

14.49. CONNECTOR COMPOSITES (1804), (1805), (1806), P. 42

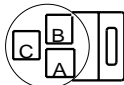
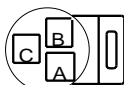
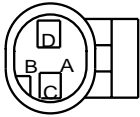
INTERNATIONAL TRUCK AND ENGINE CORPORATION <small>THIS PRINT IS PROVIDED ON A RESTRICTED BASIS AND IS NOT TO BE USED IN ANY WAY DETRIMENTAL TO THE INTEREST OF INTERNATIONAL TRUCK AND ENGINE CORPORATION.</small>	ELECTRICAL CIRCUIT DIAGRAM CHAPTER 14 CONNECTOR BODY COMPOSITE - MATING VIEW SHOWN																													
<p style="text-align: center;">SECONDARY AIR TRANSDUCER (1804) (LOCATED AT BASE OF STEERING COLUMN)</p> <div style="display: flex; justify-content: space-around; align-items: center;">  <table border="1" style="font-size: 8px;"> <thead> <tr> <th>CAV</th> <th>CIR</th> <th>GAUGE</th> <th>COLOR</th> <th>TERMINAL</th> </tr> </thead> <tbody> <tr> <td>A</td> <td>B9F</td> <td>18</td> <td>GY</td> <td>1651943C1</td> </tr> <tr> <td>B</td> <td>B6B</td> <td>18</td> <td>GY</td> <td>1651943C1</td> </tr> <tr> <td>C</td> <td>B40A</td> <td>18</td> <td>GY</td> <td>1651943C1</td> </tr> </tbody> </table> </div> <p style="text-align: center;">CONNECTOR 1678137C1</p>	CAV	CIR	GAUGE	COLOR	TERMINAL	A	B9F	18	GY	1651943C1	B	B6B	18	GY	1651943C1	C	B40A	18	GY	1651943C1										
CAV	CIR	GAUGE	COLOR	TERMINAL																										
A	B9F	18	GY	1651943C1																										
B	B6B	18	GY	1651943C1																										
C	B40A	18	GY	1651943C1																										
<p style="text-align: center;">TRANSDUCER CONNECTOR (1805) (LOCATED AT BASE OF STEERING COLUMN)</p> <div style="display: flex; justify-content: space-around; align-items: center;">  <table border="1" style="font-size: 8px;"> <thead> <tr> <th>CAV</th> <th>CIR</th> <th>GAUGE</th> <th>COLOR</th> <th>TERMINAL</th> </tr> </thead> <tbody> <tr> <td>A</td> <td>B9H</td> <td>18</td> <td>GY</td> <td>1651943C1</td> </tr> <tr> <td>B</td> <td>B6C</td> <td>18</td> <td>GY</td> <td>1651943C1</td> </tr> <tr> <td>C</td> <td>B40B</td> <td>18</td> <td>GY</td> <td>1651943C1</td> </tr> </tbody> </table> </div> <p style="text-align: center;">CONNECTOR 1678137C1</p>	CAV	CIR	GAUGE	COLOR	TERMINAL	A	B9H	18	GY	1651943C1	B	B6C	18	GY	1651943C1	C	B40B	18	GY	1651943C1										
CAV	CIR	GAUGE	COLOR	TERMINAL																										
A	B9H	18	GY	1651943C1																										
B	B6C	18	GY	1651943C1																										
C	B40B	18	GY	1651943C1																										
<p style="text-align: center;">STOP LIGHT SWITCH CONNECTOR (1806) (LOCATED AT BASE OF STEERING COLUMN)</p> <div style="display: flex; justify-content: space-around; align-items: center;">  <table border="1" style="font-size: 8px;"> <thead> <tr> <th>CAV</th> <th>CIR</th> <th>GAUGE</th> <th>COLOR</th> <th>TERMINAL</th> <th>SEAL/SLEEVE</th> </tr> </thead> <tbody> <tr> <td>C</td> <td>B70</td> <td>18</td> <td>OR</td> <td>1661875C1</td> <td>1661872C1</td> </tr> <tr> <td>D</td> <td>B9K</td> <td>18</td> <td>GY</td> <td>1661875C1</td> <td>1661872C1</td> </tr> </tbody> </table> </div> <p style="text-align: center;">CONNECTOR 1661777C1</p>	CAV	CIR	GAUGE	COLOR	TERMINAL	SEAL/SLEEVE	C	B70	18	OR	1661875C1	1661872C1	D	B9K	18	GY	1661875C1	1661872C1												
CAV	CIR	GAUGE	COLOR	TERMINAL	SEAL/SLEEVE																									
C	B70	18	OR	1661875C1	1661872C1																									
D	B9K	18	GY	1661875C1	1661872C1																									
<table border="1" style="width:100%; border-collapse: collapse;"> <thead> <tr> <th>CHK</th> <th>DATE</th> <th>CHANGE</th> <th>REV</th> <th>REFERENCE</th> <th>DRAWN</th> <th>NAME</th> </tr> </thead> <tbody> <tr> <td>CNA1</td> <td>14JAN09</td> <td>TITLE WAS CIRCUIT</td> <td>A</td> <td>61254R</td> <td>U00K640</td> <td>CIRCUIT DIAGRAM, PROSTAR, LONESTAR</td> </tr> <tr> <td></td> <td></td> <td>DIAGRAM, PROSTAR</td> <td></td> <td></td> <td>59637L</td> <td>06SEP06</td> </tr> </tbody> </table>	CHK	DATE	CHANGE	REV	REFERENCE	DRAWN	NAME	CNA1	14JAN09	TITLE WAS CIRCUIT	A	61254R	U00K640	CIRCUIT DIAGRAM, PROSTAR, LONESTAR			DIAGRAM, PROSTAR			59637L	06SEP06	<table border="1" style="width:100%; border-collapse: collapse;"> <thead> <tr> <th>RELEASE NO.</th> <th>DATE</th> <th>PART NO.</th> <th>SHEET</th> </tr> </thead> <tbody> <tr> <td>59637L</td> <td>06SEP06</td> <td>AE08055906</td> <td>042</td> </tr> </tbody> </table>	RELEASE NO.	DATE	PART NO.	SHEET	59637L	06SEP06	AE08055906	042
CHK	DATE	CHANGE	REV	REFERENCE	DRAWN	NAME																								
CNA1	14JAN09	TITLE WAS CIRCUIT	A	61254R	U00K640	CIRCUIT DIAGRAM, PROSTAR, LONESTAR																								
		DIAGRAM, PROSTAR			59637L	06SEP06																								
RELEASE NO.	DATE	PART NO.	SHEET																											
59637L	06SEP06	AE08055906	042																											

Figure 278 Connector Composites (1804), (1805), (1806)

14.50. CONNECTOR COMPOSITES (1808), (1809), (1810), P. 43

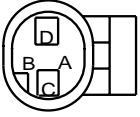
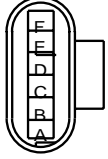
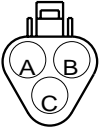
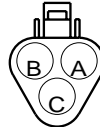
INTERNATIONAL TRUCK AND ENGINE CORPORATION				ELECTRICAL CIRCUIT DIAGRAM CHAPTER 14																																						
THIS PRINT IS PROVIDED ON A RESTRICTED BASIS AND IS NOT TO BE USED IN ANY WAY DETRIMENTAL TO THE INTEREST OF INTERNATIONAL TRUCK AND ENGINE CORPORATION.				CONNECTOR BODY COMPOSITE - MATING VIEW SHOWN																																						
<p>PARK BRAKE (1808) (LOCATED AT BASE OF STEERING COLUMN)</p>  <table border="1" style="margin-left: auto; margin-right: auto;"> <thead> <tr> <th>CAV</th> <th>CIR</th> <th>GAUGE</th> <th>COLOR</th> <th>TERMINAL</th> <th>SEAL/SLEEVE</th> </tr> </thead> <tbody> <tr> <td>C</td> <td>B44</td> <td>18</td> <td>GY</td> <td>1661875C1</td> <td>1661872C1</td> </tr> <tr> <td>D</td> <td>B9J</td> <td>18</td> <td>GY</td> <td>1661875C1</td> <td>1661872C1</td> </tr> </tbody> </table> <p>CONNECTOR 1661777C1 BODY LOCK 1661873C1</p>								CAV	CIR	GAUGE	COLOR	TERMINAL	SEAL/SLEEVE	C	B44	18	GY	1661875C1	1661872C1	D	B9J	18	GY	1661875C1	1661872C1																	
CAV	CIR	GAUGE	COLOR	TERMINAL	SEAL/SLEEVE																																					
C	B44	18	GY	1661875C1	1661872C1																																					
D	B9J	18	GY	1661875C1	1661872C1																																					
<p>ACCELERATOR PEDAL (1809) (LOCATED ABOVE ACCELERATOR PEDAL)</p>  <table border="1" style="margin-left: auto; margin-right: auto;"> <thead> <tr> <th>CAV</th> <th>CIR</th> <th>GAUGE</th> <th>COLOR</th> <th>TERMINAL</th> </tr> </thead> <tbody> <tr> <td>A</td> <td>B99B</td> <td>18</td> <td>VT</td> <td>1651943C1</td> </tr> <tr> <td>B</td> <td>B97B</td> <td>18</td> <td>VT</td> <td>1651943C1</td> </tr> <tr> <td>C</td> <td>B97C</td> <td>18</td> <td>VT</td> <td>1651943C1</td> </tr> <tr> <td>D</td> <td>B99D</td> <td>18</td> <td>VT</td> <td>1651943C1</td> </tr> <tr> <td>E</td> <td>B97N</td> <td>18</td> <td>VT</td> <td>1651943C1</td> </tr> <tr> <td>F</td> <td>B97M</td> <td>18</td> <td>VT</td> <td>1651943C1</td> </tr> </tbody> </table> <p>CONNECTOR 1687790C1</p>								CAV	CIR	GAUGE	COLOR	TERMINAL	A	B99B	18	VT	1651943C1	B	B97B	18	VT	1651943C1	C	B97C	18	VT	1651943C1	D	B99D	18	VT	1651943C1	E	B97N	18	VT	1651943C1	F	B97M	18	VT	1651943C1
CAV	CIR	GAUGE	COLOR	TERMINAL																																						
A	B99B	18	VT	1651943C1																																						
B	B97B	18	VT	1651943C1																																						
C	B97C	18	VT	1651943C1																																						
D	B99D	18	VT	1651943C1																																						
E	B97N	18	VT	1651943C1																																						
F	B97M	18	VT	1651943C1																																						
<p>ACCELERATOR PEDAL (1810) (LOCATED ABOVE ACCELERATOR PEDAL) (W/ PROSTAR)</p>  <table border="1" style="margin-left: auto; margin-right: auto;"> <thead> <tr> <th>CAV</th> <th>CIR</th> <th>GAUGE</th> <th>COLOR</th> <th>TERMINAL</th> </tr> </thead> <tbody> <tr> <td>A</td> <td>B97C</td> <td>18</td> <td>GY</td> <td>3572625C1</td> </tr> <tr> <td>B</td> <td>B97B</td> <td>18</td> <td>VT</td> <td>3572625C1</td> </tr> <tr> <td>C</td> <td>B99B</td> <td>18</td> <td>VT</td> <td>3572625C1</td> </tr> </tbody> </table> <p>CONNECTOR 0453133C1 BODY LOCK 1655704C1</p>								CAV	CIR	GAUGE	COLOR	TERMINAL	A	B97C	18	GY	3572625C1	B	B97B	18	VT	3572625C1	C	B99B	18	VT	3572625C1															
CAV	CIR	GAUGE	COLOR	TERMINAL																																						
A	B97C	18	GY	3572625C1																																						
B	B97B	18	VT	3572625C1																																						
C	B99B	18	VT	3572625C1																																						
<p>ACCELERATOR PEDAL (1810) (LOCATED ABOVE ACCELERATOR PEDAL) (W/ LONESTAR)</p>  <table border="1" style="margin-left: auto; margin-right: auto;"> <thead> <tr> <th>CAV</th> <th>CIR</th> <th>GAUGE</th> <th>COLOR</th> <th>TERMINAL</th> </tr> </thead> <tbody> <tr> <td>A</td> <td>B97C</td> <td>18</td> <td>GY</td> <td>1680205C1</td> </tr> <tr> <td>B</td> <td>B97B</td> <td>18</td> <td>VT</td> <td>1680205C1</td> </tr> <tr> <td>C</td> <td>B99B</td> <td>18</td> <td>VT</td> <td>1680205C1</td> </tr> </tbody> </table> <p>CONNECTOR 1655702C1 BODY LOCK 1655704C1</p>								CAV	CIR	GAUGE	COLOR	TERMINAL	A	B97C	18	GY	1680205C1	B	B97B	18	VT	1680205C1	C	B99B	18	VT	1680205C1															
CAV	CIR	GAUGE	COLOR	TERMINAL																																						
A	B97C	18	GY	1680205C1																																						
B	B97B	18	VT	1680205C1																																						
C	B99B	18	VT	1680205C1																																						
CHK	DATE	CHANGE	REV	REFERENCE	DRAWN	NAME																																				
CNA1	14JAN09	ADDED LONESTAR EFFECT	A	61254R	U00K640	CIRCUIT DIAGRAM, PROSTAR, LONESTAR																																				
					RELEASE NO.	DATE	PART NO.																																			
					59637L	06SEP06	AE08055906																																			
							SHEET 043																																			

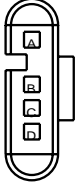
Figure 279 Connector Composites (1808), (1809), (1810)

14.51. CONNECTOR COMPOSITES (1811), (1812), (1820F/1820M), P. 44

INTERNATIONAL TRUCK AND ENGINE CORPORATION		ELECTRICAL CIRCUIT DIAGRAM		CHAPTER 14	
THIS PRINT IS PROVIDED ON A RESTRICTED BASIS AND IS NOT TO BE USED IN ANY WAY DETRIMENTAL TO THE INTEREST OF INTERNATIONAL TRUCK AND ENGINE CORPORATION.		CONNECTOR BODY COMPOSITE - MATING VIEW SHOWN			

CLUTCH SWITCH  
(1811)  
(LOCATED ON CLUTCH PEDAL)

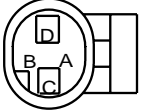


CONNECTOR 3540757C1  
BODY LOCK 3540758C1

CAV	CIR	GAUGE	COLOR	TERMINAL	SEAL/SLEEVE
A	B17A	18	PK	1667742C1	1661872C1
B	B17AA	18	PK	1667742C1	1661872C1
C	B97A	18	VT	1667742C1	1661872C1
D	B9M	18	GY	1667742C1	1661872C1

BRAKE INPUT  
(1812)  
(LOCATED AT BASE OF STEERING COLUMN)




CONNECTOR 1661777C1  
BODY LOCK 1661873C1

CAV	CIR	GAUGE	COLOR	TERMINAL	SEAL/SLEEVE
D	B70D	18	GY	1661875C1	1661872C1
C	B70E	18	OR	1661875C1	1661872C1


  

CAB HARNESS STEERING WHEEL SENSOR  
(1820F / 1820M)  
(LOCATED IN INSTRUMENT PANEL TO RIGHT OF STEERING COLUMN)



CONNECTOR 1667529C1  
BODY LOCK 1667530C1

CAV	CIR	GAUGE	COLOR	TERMINAL
A	B94SA	20	GY	3534481C1
B	B94SB	20	GY	3534481C1
C	B94SC	20	GY	3534481C1
D	B94SD	20	GY	3534481C1



CONNECTOR 1667305C1  
BODY LOCK 1661263C1

CAV	CIR	GAUGE	COLOR	TERMINAL
A	A94SA	18	GY	1661261C1
B	A94SB	18	GY	1661261C1
C	A94SC	18	GY	1661261C1
D	A94SD	18	GY	1661261C1

CHK	DATE	CHANGE	REV	REFERENCE	DRAWN	NAME
CNA1	14JAN09	TITLE WAS CIRCUIT	A	61254R	U00K640	CIRCUIT DIAGRAM, PROSTAR, LONESTAR
		DIAGRAM, PROSTAR			59637L	06SEP06
						AE08055906
						044

Figure 280 Connector Composites (1811), (1812), (1820F/1820M)

14.52. CONNECTOR COMPOSITES (1821), (1822), (1823), (1824), P. 45

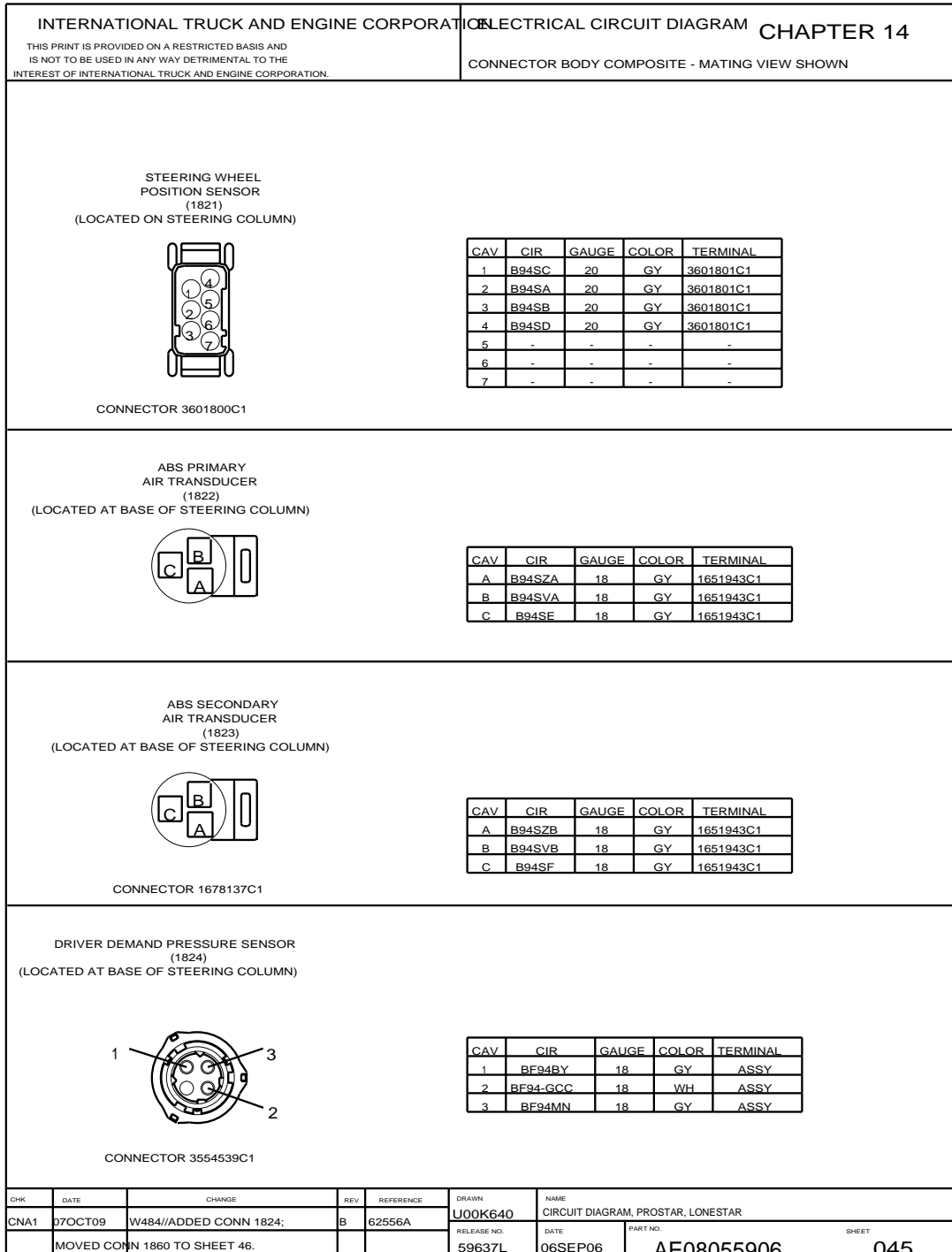


Figure 281 Connector Composites (1821), (1822), (1823), (1824)

14.53. CONNECTOR COMPOSITES (1860), (1861), (1901), (1903), P. 46


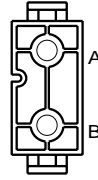


INTERNATIONAL TRUCK AND ENGINE CORPORATION		ELECTRICAL CIRCUIT DIAGRAM		CHAPTER 14																					
THIS PRINT IS PROVIDED ON A RESTRICTED BASIS AND IS NOT TO BE USED IN ANY WAY DETRIMENTAL TO THE INTEREST OF INTERNATIONAL TRUCK AND ENGINE CORPORATION.		CONNECTOR BODY COMPOSITE - MATING VIEW SHOWN																							
<p>CIGAR LIGHTER TYPE POWER SOURCE (1860) (LOCATED IN INSTRUMENT PANEL - CENTER) (JUMPER HARNESS) (W/ PROSTAR)</p>  <p>CONNECTOR 3613000C1</p> <table border="1" style="margin-left: auto; margin-right: auto;"> <thead> <tr> <th>CAV</th> <th>CIR</th> <th>GAUGE</th> <th>COLOR</th> <th>TERMINAL</th> </tr> </thead> <tbody> <tr> <td>A</td> <td>A86M</td> <td>16</td> <td>LT GN</td> <td>3534165C1</td> </tr> <tr> <td>B</td> <td>-</td> <td>-</td> <td>-</td> <td>-</td> </tr> <tr> <td>C</td> <td>A86-GA</td> <td>16</td> <td>WH</td> <td>3534165C1</td> </tr> </tbody> </table>						CAV	CIR	GAUGE	COLOR	TERMINAL	A	A86M	16	LT GN	3534165C1	B	-	-	-	-	C	A86-GA	16	WH	3534165C1
CAV	CIR	GAUGE	COLOR	TERMINAL																					
A	A86M	16	LT GN	3534165C1																					
B	-	-	-	-																					
C	A86-GA	16	WH	3534165C1																					
<p>TWO POST POWER SOURCE (1861) (LOCATED IN INSTRUMENT PANEL CENTER) (JUMPER HARNESS)</p>  <p>CONNECTOR 3517473C1</p> <table border="1" style="margin-left: auto; margin-right: auto;"> <thead> <tr> <th>CAV</th> <th>CIR</th> <th>GAUGE</th> <th>COLOR</th> <th>TERMINAL</th> </tr> </thead> <tbody> <tr> <td>A</td> <td>B86N</td> <td>14</td> <td>LTGN</td> <td>3517476C1</td> </tr> <tr> <td>B</td> <td>B86-GB</td> <td>14</td> <td>WH</td> <td>3517476C1</td> </tr> </tbody> </table>						CAV	CIR	GAUGE	COLOR	TERMINAL	A	B86N	14	LTGN	3517476C1	B	B86-GB	14	WH	3517476C1					
CAV	CIR	GAUGE	COLOR	TERMINAL																					
A	B86N	14	LTGN	3517476C1																					
B	B86-GB	14	WH	3517476C1																					
<p>AUX POWER (1901) (LOCATED IN INSTRUMENT PANEL - CENTER)</p>  <p>CONNECTOR 1661196C1</p> <table border="1" style="margin-left: auto; margin-right: auto;"> <thead> <tr> <th>CAV</th> <th>CIR</th> <th>GAUGE</th> <th>COLOR</th> <th>TERMINAL</th> </tr> </thead> <tbody> <tr> <td>A</td> <td>A86P</td> <td>16</td> <td>LTGN</td> <td>1661208C1</td> </tr> <tr> <td>B</td> <td>A86-GP</td> <td>16</td> <td>WH</td> <td>1661208C1</td> </tr> </tbody> </table>						CAV	CIR	GAUGE	COLOR	TERMINAL	A	A86P	16	LTGN	1661208C1	B	A86-GP	16	WH	1661208C1					
CAV	CIR	GAUGE	COLOR	TERMINAL																					
A	A86P	16	LTGN	1661208C1																					
B	A86-GP	16	WH	1661208C1																					
<p>CIGAR LIGHTER (1903) (LOCATED IN INSTRUMENT PANEL)</p>  <table border="1" style="margin-left: auto; margin-right: auto;"> <thead> <tr> <th>CAV</th> <th>CIR</th> <th>GAUGE</th> <th>COLOR</th> <th>TERMINAL</th> </tr> </thead> <tbody> <tr> <td>A</td> <td>A84</td> <td>16</td> <td>LTGN</td> <td>3534165C1</td> </tr> <tr> <td>B</td> <td>-</td> <td>-</td> <td>-</td> <td>-</td> </tr> <tr> <td>C</td> <td>A84-G</td> <td>16</td> <td>WH</td> <td>3534165C1</td> </tr> </tbody> </table>						CAV	CIR	GAUGE	COLOR	TERMINAL	A	A84	16	LTGN	3534165C1	B	-	-	-	-	C	A84-G	16	WH	3534165C1
CAV	CIR	GAUGE	COLOR	TERMINAL																					
A	A84	16	LTGN	3534165C1																					
B	-	-	-	-																					
C	A84-G	16	WH	3534165C1																					
CHK	DATE	CHANGE	REV	REFERENCE	DRAWN	NAME																			
CNA1	07OCT09	W484//ADDED CONN 1860	B	62556A	U00K640	CIRCUIT DIAGRAM, PROSTAR, LONESTAR																			
					RELEASE NO.	DATE																			
					59637L	06SEP06																			
					PART NO.	SHEET																			
					AE08055906	046																			

Figure 282 Connector Composites (1860), (1861), (1901), (1903)

14.54. CONNECTOR COMPOSITES (1906), (1907), (1909M), (1910), (1912), (1916), P. 47

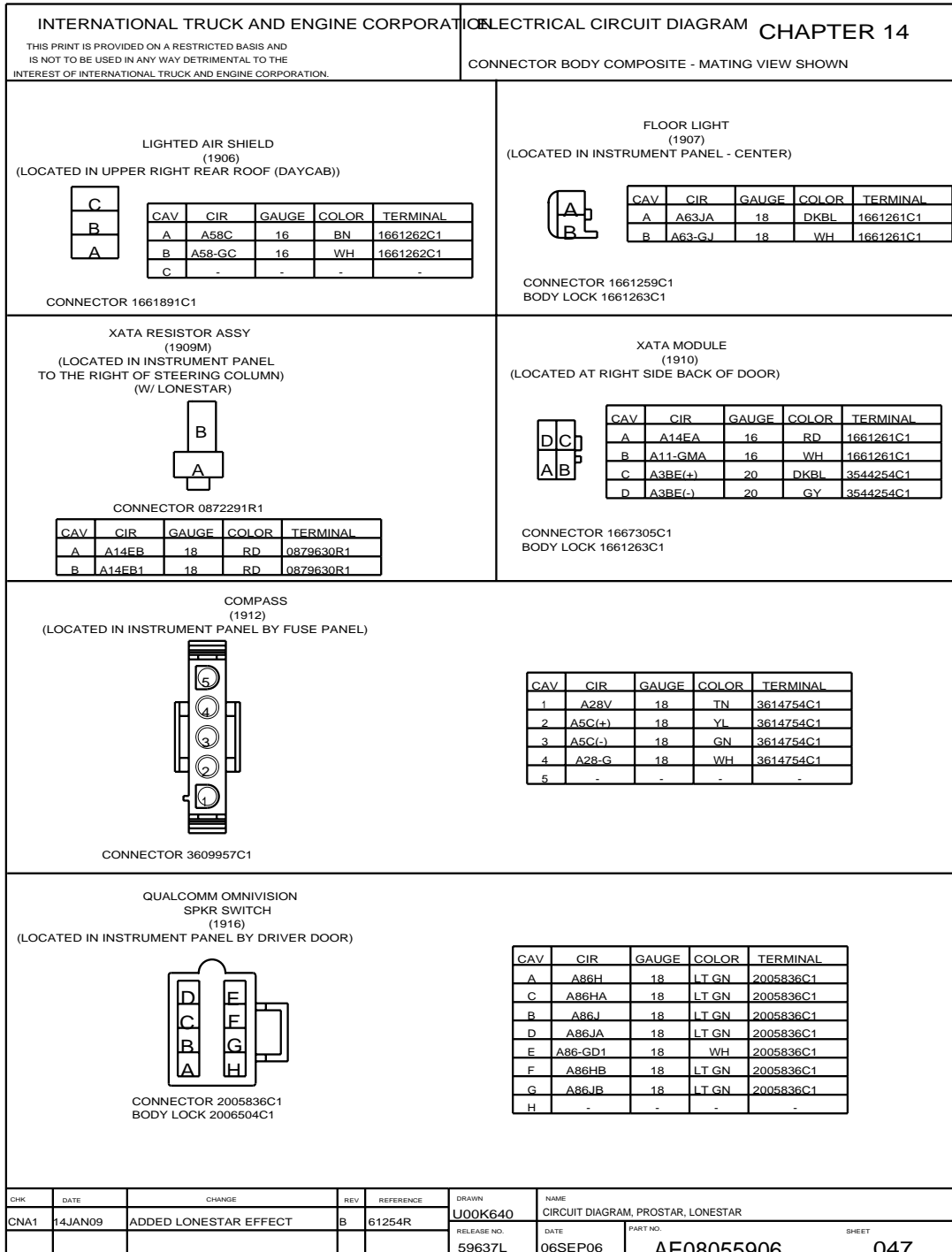


Figure 283 Connector Composites (1906), (1907), (1909M), (1910), (1912), (1916)

14.55. CONNECTOR COMPOSITES (1917), (1918/1918A), (1919/1919A), (1920), (1922), (1922M), P. 48

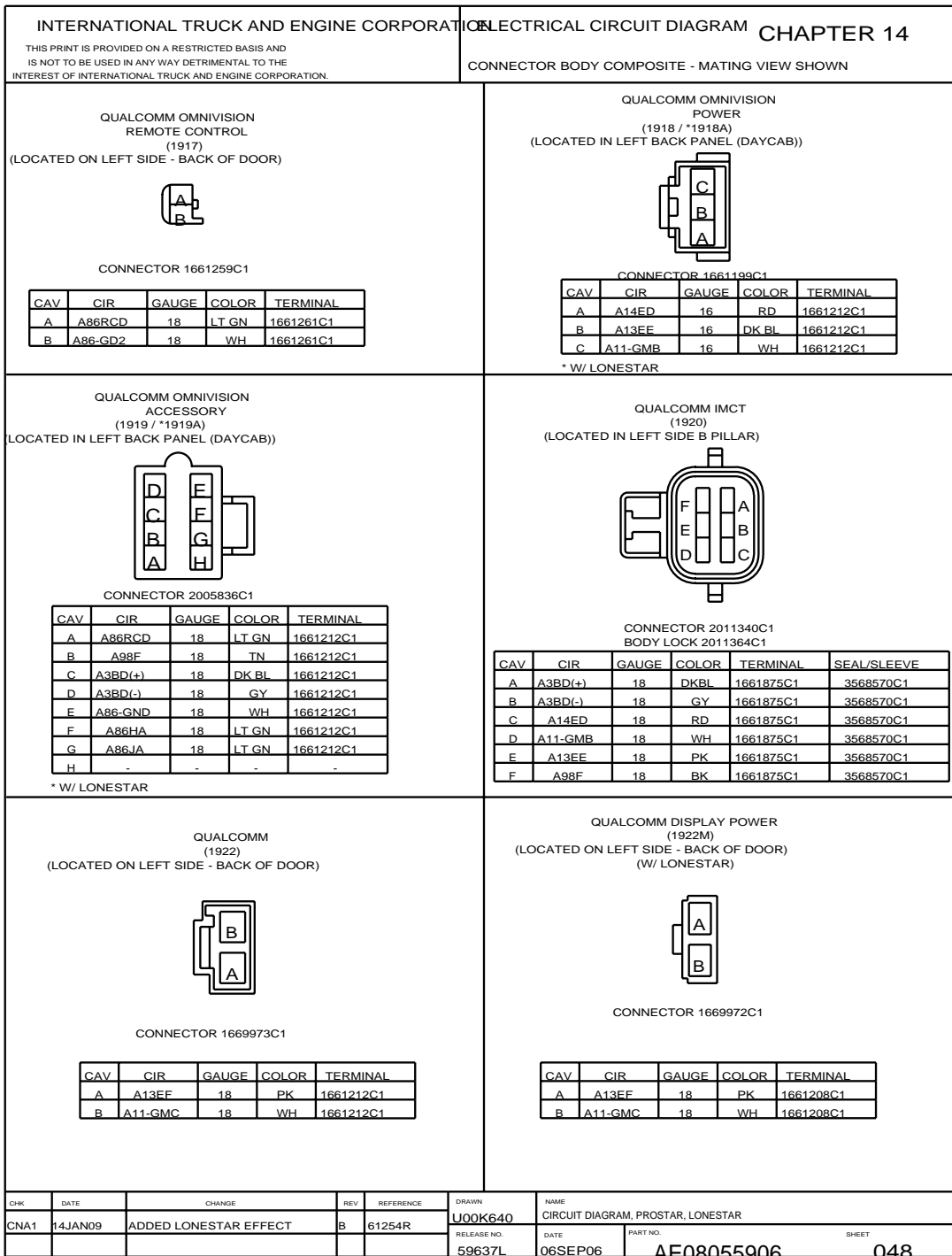


Figure 284 Connector Composites (1917), (1918/1918A), (1919/1919A), (1920), (1922), (1922M)

14.56. CONNECTOR COMPOSITES (1923), (1925), P. 49

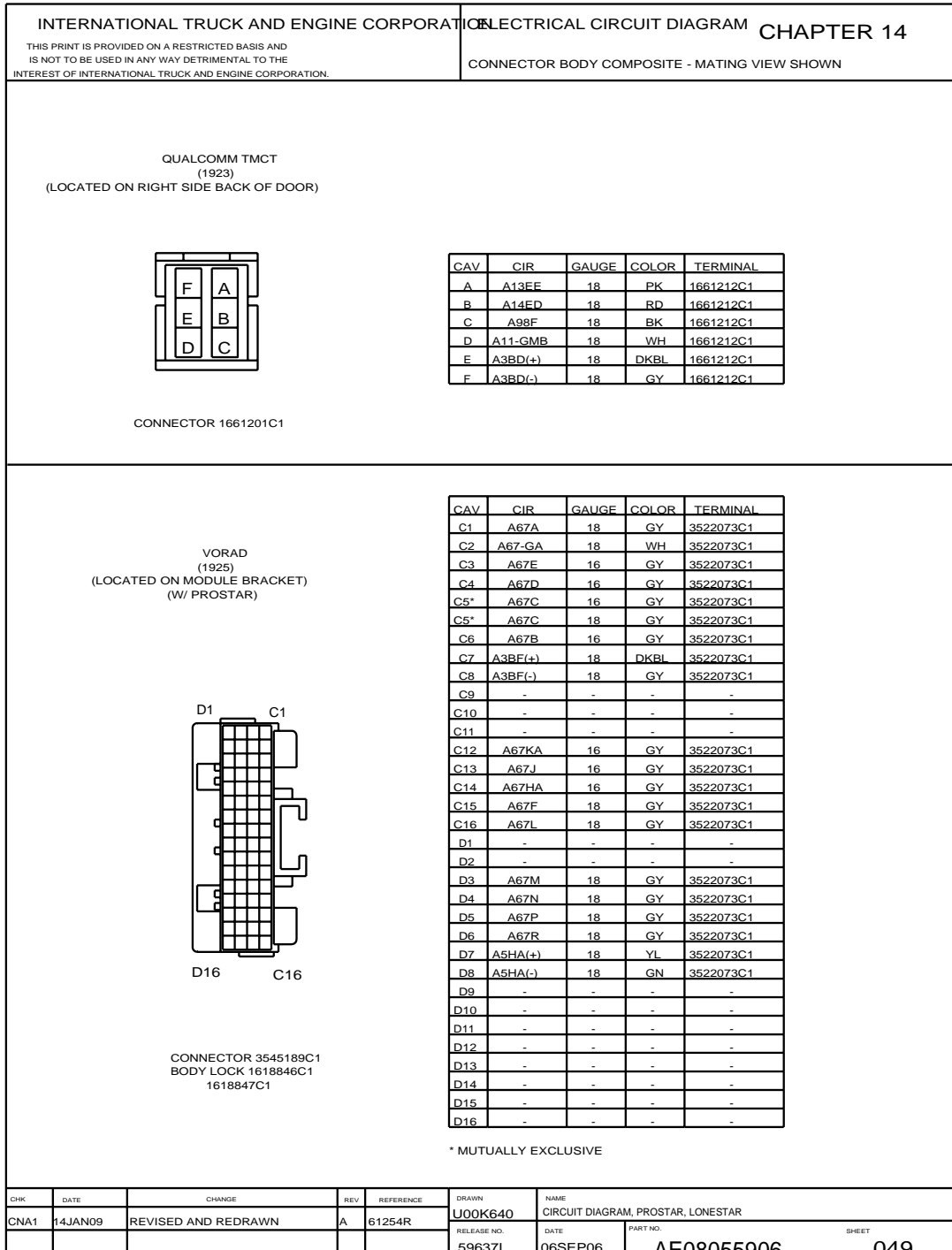


Figure 285 Connector Composites (1923), (1925)

14.57. CONNECTOR COMPOSITES (1927), (1929), (1930), (1931), P. 50

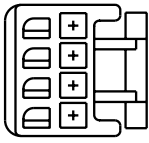
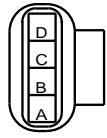
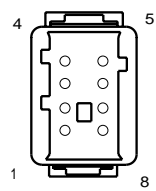
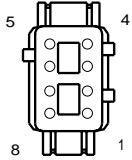
INTERNATIONAL TRUCK AND ENGINE CORPORATION		ELECTRICAL CIRCUIT DIAGRAM		CHAPTER 14																																														
THIS PRINT IS PROVIDED ON A RESTRICTED BASIS AND IS NOT TO BE USED IN ANY WAY DETRIMENTAL TO THE INTEREST OF INTERNATIONAL TRUCK AND ENGINE CORPORATION.		CONNECTOR BODY COMPOSITE - MATING VIEW SHOWN																																																
<p style="text-align: center;">VORAD DISPLAY CONNECTION (1927) (LOCATED IN RIGHT SIDE A PILLAR)</p> <div style="display: flex; justify-content: space-around;">  <table border="1" style="font-size: x-small;"> <thead> <tr> <th>CAV</th> <th>CIR</th> <th>GAUGE</th> <th>COLOR</th> <th>TERMINAL</th> </tr> </thead> <tbody> <tr> <td>1</td> <td>-</td> <td>-</td> <td>-</td> <td>-</td> </tr> <tr> <td>2</td> <td>A67KB</td> <td>16</td> <td>GY</td> <td>3522073C1</td> </tr> <tr> <td>3</td> <td>A67HB</td> <td>16</td> <td>GY</td> <td>3522073C1</td> </tr> <tr> <td>4</td> <td>A67L</td> <td>16</td> <td>GY</td> <td>3522073C1</td> </tr> </tbody> </table> </div> <p style="text-align: center;">CONNECTOR 3545777C1 BODY LOCK 3545778C1</p>						CAV	CIR	GAUGE	COLOR	TERMINAL	1	-	-	-	-	2	A67KB	16	GY	3522073C1	3	A67HB	16	GY	3522073C1	4	A67L	16	GY	3522073C1																				
CAV	CIR	GAUGE	COLOR	TERMINAL																																														
1	-	-	-	-																																														
2	A67KB	16	GY	3522073C1																																														
3	A67HB	16	GY	3522073C1																																														
4	A67L	16	GY	3522073C1																																														
<p style="text-align: center;">VORAD DISPLAY (1929) (LOCATED ON TOP OF INSTRUMENT PANEL)</p> <div style="display: flex; justify-content: space-around;">  <table border="1" style="font-size: x-small;"> <thead> <tr> <th>CAV</th> <th>CIR</th> <th>GAUGE</th> <th>COLOR</th> <th>TERMINAL</th> </tr> </thead> <tbody> <tr> <td>A</td> <td>A67R</td> <td>18</td> <td>GY</td> <td>2036586C1</td> </tr> <tr> <td>B</td> <td>A67P</td> <td>18</td> <td>GY</td> <td>2036586C1</td> </tr> <tr> <td>C</td> <td>A67N</td> <td>18</td> <td>GY</td> <td>2036586C1</td> </tr> <tr> <td>D</td> <td>A67M</td> <td>18</td> <td>GY</td> <td>2036586C1</td> </tr> </tbody> </table> </div> <p style="text-align: center;">CONNECTOR 2036585C1</p>						CAV	CIR	GAUGE	COLOR	TERMINAL	A	A67R	18	GY	2036586C1	B	A67P	18	GY	2036586C1	C	A67N	18	GY	2036586C1	D	A67M	18	GY	2036586C1																				
CAV	CIR	GAUGE	COLOR	TERMINAL																																														
A	A67R	18	GY	2036586C1																																														
B	A67P	18	GY	2036586C1																																														
C	A67N	18	GY	2036586C1																																														
D	A67M	18	GY	2036586C1																																														
<p style="text-align: center;">ICON MODULE "B" CONNECTOR (1930) (LOCATED ON MODULE BRACKET) (W/ PROSTAR)</p> <div style="display: flex; justify-content: space-around;">  <table border="1" style="font-size: x-small;"> <thead> <tr> <th>CAV</th> <th>CIR</th> <th>GAUGE</th> <th>COLOR</th> <th>TERMINAL</th> </tr> </thead> <tbody> <tr> <td>1</td> <td>PLUG</td> <td>-</td> <td>-</td> <td>3527276C1</td> </tr> <tr> <td>2</td> <td>A97N</td> <td>16</td> <td>VT</td> <td>3518961C1</td> </tr> <tr> <td>3</td> <td>A17HC</td> <td>18</td> <td>PK</td> <td>3518961C1</td> </tr> <tr> <td>4</td> <td>A97X</td> <td>18</td> <td>VT</td> <td>3518961C1</td> </tr> <tr> <td>5</td> <td>A17HD</td> <td>16</td> <td>PK</td> <td>3518961C1</td> </tr> <tr> <td>6</td> <td>A17HF</td> <td>18</td> <td>PK</td> <td>3518961C1</td> </tr> <tr> <td>7</td> <td>A3H (+)</td> <td>18</td> <td>DKBL</td> <td>3518961C1</td> </tr> <tr> <td>8</td> <td>A3H (-)</td> <td>18</td> <td>GY</td> <td>3518961C1</td> </tr> </tbody> </table> </div> <p style="text-align: center;">CONNECTOR 3539140C1 BODY LOCK 3539145C1</p>						CAV	CIR	GAUGE	COLOR	TERMINAL	1	PLUG	-	-	3527276C1	2	A97N	16	VT	3518961C1	3	A17HC	18	PK	3518961C1	4	A97X	18	VT	3518961C1	5	A17HD	16	PK	3518961C1	6	A17HF	18	PK	3518961C1	7	A3H (+)	18	DKBL	3518961C1	8	A3H (-)	18	GY	3518961C1
CAV	CIR	GAUGE	COLOR	TERMINAL																																														
1	PLUG	-	-	3527276C1																																														
2	A97N	16	VT	3518961C1																																														
3	A17HC	18	PK	3518961C1																																														
4	A97X	18	VT	3518961C1																																														
5	A17HD	16	PK	3518961C1																																														
6	A17HF	18	PK	3518961C1																																														
7	A3H (+)	18	DKBL	3518961C1																																														
8	A3H (-)	18	GY	3518961C1																																														
<p style="text-align: center;">ICON MODULE "A" CONNECTOR (1931) (LOCATED ON MODULE BRACKET) (W/ PROSTAR)</p> <div style="display: flex; justify-content: space-around;">  <table border="1" style="font-size: x-small;"> <thead> <tr> <th>CAV</th> <th>CIR</th> <th>GAUGE</th> <th>COLOR</th> <th>TERMINAL</th> </tr> </thead> <tbody> <tr> <td>1</td> <td>A14HHA</td> <td>18</td> <td>RD</td> <td>3518963C1</td> </tr> <tr> <td>2</td> <td>A11-GEC</td> <td>16</td> <td>WH</td> <td>3518963C1</td> </tr> <tr> <td>3</td> <td>A97S</td> <td>18</td> <td>VT</td> <td>3518963C1</td> </tr> <tr> <td>4</td> <td>A97T</td> <td>18</td> <td>VT</td> <td>3518963C1</td> </tr> <tr> <td>5</td> <td>A97U</td> <td>18</td> <td>VT</td> <td>3518963C1</td> </tr> <tr> <td>6</td> <td>A97V</td> <td>18</td> <td>VT</td> <td>3518963C1</td> </tr> <tr> <td>7</td> <td>A13HA</td> <td>18</td> <td>PK</td> <td>3518963C1</td> </tr> <tr> <td>8</td> <td>A17HB</td> <td>18</td> <td>PK</td> <td>3518963C1</td> </tr> </tbody> </table> </div> <p style="text-align: center;">CONNECTOR 3539139C1 BODY LOCK 3539144C1</p>						CAV	CIR	GAUGE	COLOR	TERMINAL	1	A14HHA	18	RD	3518963C1	2	A11-GEC	16	WH	3518963C1	3	A97S	18	VT	3518963C1	4	A97T	18	VT	3518963C1	5	A97U	18	VT	3518963C1	6	A97V	18	VT	3518963C1	7	A13HA	18	PK	3518963C1	8	A17HB	18	PK	3518963C1
CAV	CIR	GAUGE	COLOR	TERMINAL																																														
1	A14HHA	18	RD	3518963C1																																														
2	A11-GEC	16	WH	3518963C1																																														
3	A97S	18	VT	3518963C1																																														
4	A97T	18	VT	3518963C1																																														
5	A97U	18	VT	3518963C1																																														
6	A97V	18	VT	3518963C1																																														
7	A13HA	18	PK	3518963C1																																														
8	A17HB	18	PK	3518963C1																																														
CHK	DATE	CHANGE	REV	REFERENCE	DRAWN	NAME																																												
CNA1	14JAN09	TITLE WAS CIRCUIT	A	61254R	U00K640	CIRCUIT DIAGRAM, PROSTAR, LONESTAR																																												
		DIAGRAM, PROSTAR			RELEASE NO. 59637L	DATE 06SEPO6																																												
						PART NO. AE08055906																																												
						SHEET 050																																												

Figure 286 Connector Composites (1927), (1929), (1930), (1931)

14.58. CONNECTOR COMPOSITES (1932), (1933), (1942/1942F), (1943), (1943M), P. 50A

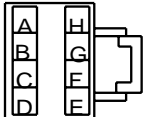
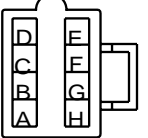



INTERNATIONAL TRUCK AND ENGINE CORPORATION				ELECTRICAL CIRCUIT DIAGRAM CHAPTER 14																																														
THIS PRINT IS PROVIDED ON A RESTRICTED BASIS AND IS NOT TO BE USED IN ANY WAY DETRIMENTAL TO THE INTEREST OF INTERNATIONAL TRUCK AND ENGINE CORPORATION.				CONNECTOR BODY COMPOSITE - MATING VIEW SHOWN																																														
<p style="text-align: center;">QUALCOM TMCT (1932) (LOCATED IN LEFT BACK PANEL(DAYCAB))</p> <div style="display: flex; justify-content: space-around; align-items: center;">  <table border="1" style="font-size: x-small;"> <thead> <tr><th>CAV</th><th>CIR</th><th>GAUGE</th><th>COLOR</th><th>TERMINAL</th></tr> </thead> <tbody> <tr><td>A</td><td>A14EA</td><td>18</td><td>RD</td><td>1661208C1</td></tr> <tr><td>B</td><td>A14EE</td><td>18</td><td>RD</td><td>1661208C1</td></tr> <tr><td>C</td><td>A11-GMC</td><td>18</td><td>WH</td><td>1661208C1</td></tr> <tr><td>D</td><td>A11-GMA</td><td>18</td><td>WH</td><td>1661208C1</td></tr> <tr><td>E</td><td>A13EE</td><td>18</td><td>PK</td><td>1661208C1</td></tr> <tr><td>F</td><td>A3BD(+)</td><td>18</td><td>DKBL</td><td>1661208C1</td></tr> <tr><td>G</td><td>A3BD(-)</td><td>18</td><td>GY</td><td>1661208C1</td></tr> <tr><td>H</td><td>-</td><td>-</td><td>-</td><td>-</td></tr> </tbody> </table> </div> <p style="text-align: center;">CONNECTOR 2005835C1 BODY LOCK 2006503C1</p>						CAV	CIR	GAUGE	COLOR	TERMINAL	A	A14EA	18	RD	1661208C1	B	A14EE	18	RD	1661208C1	C	A11-GMC	18	WH	1661208C1	D	A11-GMA	18	WH	1661208C1	E	A13EE	18	PK	1661208C1	F	A3BD(+)	18	DKBL	1661208C1	G	A3BD(-)	18	GY	1661208C1	H	-	-	-	-
CAV	CIR	GAUGE	COLOR	TERMINAL																																														
A	A14EA	18	RD	1661208C1																																														
B	A14EE	18	RD	1661208C1																																														
C	A11-GMC	18	WH	1661208C1																																														
D	A11-GMA	18	WH	1661208C1																																														
E	A13EE	18	PK	1661208C1																																														
F	A3BD(+)	18	DKBL	1661208C1																																														
G	A3BD(-)	18	GY	1661208C1																																														
H	-	-	-	-																																														
<p style="text-align: center;">MOTIENT MOBILE MAX DISCRETE I/O (1933) (LOCATED IN LEFT BACK PANEL(DAYCAB))</p> <div style="display: flex; justify-content: space-around; align-items: center;">  <table border="1" style="font-size: x-small;"> <thead> <tr><th>CAV</th><th>CIR</th><th>GAUGE</th><th>COLOR</th><th>TERMINAL</th></tr> </thead> <tbody> <tr><td>A</td><td>-</td><td>-</td><td>-</td><td>-</td></tr> <tr><td>B</td><td>A98F</td><td>18</td><td>LTGN</td><td>1661212C1</td></tr> <tr><td>C</td><td>-</td><td>-</td><td>-</td><td>-</td></tr> <tr><td>D</td><td>-</td><td>-</td><td>-</td><td>-</td></tr> <tr><td>E</td><td>-</td><td>-</td><td>-</td><td>-</td></tr> <tr><td>F</td><td>-</td><td>-</td><td>-</td><td>-</td></tr> <tr><td>G</td><td>-</td><td>-</td><td>-</td><td>-</td></tr> <tr><td>H</td><td>-</td><td>-</td><td>-</td><td>-</td></tr> </tbody> </table> </div> <p style="text-align: center;">CONNECTOR 2005836C1 BODY LOCK 2006504C1</p>						CAV	CIR	GAUGE	COLOR	TERMINAL	A	-	-	-	-	B	A98F	18	LTGN	1661212C1	C	-	-	-	-	D	-	-	-	-	E	-	-	-	-	F	-	-	-	-	G	-	-	-	-	H	-	-	-	-
CAV	CIR	GAUGE	COLOR	TERMINAL																																														
A	-	-	-	-																																														
B	A98F	18	LTGN	1661212C1																																														
C	-	-	-	-																																														
D	-	-	-	-																																														
E	-	-	-	-																																														
F	-	-	-	-																																														
G	-	-	-	-																																														
H	-	-	-	-																																														
<p style="text-align: center;">EATON VORAD RIGHT SIDE DISPLAY (1942 / *1942F) (LOCATED IN INSTRUMENT PANEL TO THE RIGHT OF STEERING COLUMN) (W/ PROSTAR)</p> <div style="display: flex; justify-content: space-around; align-items: center;">  <table border="1" style="font-size: x-small;"> <thead> <tr><th>CAV</th><th>CIR</th><th>GAUGE</th><th>COLOR</th><th>TERMINAL</th></tr> </thead> <tbody> <tr><td>1</td><td>A67V</td><td>18</td><td>GY</td><td>1680206C1</td></tr> <tr><td>2</td><td>A67W</td><td>18</td><td>GY</td><td>1680206C1</td></tr> <tr><td>3</td><td>A67U</td><td>18</td><td>GY</td><td>1680206C1</td></tr> <tr><td>4</td><td>A57NA</td><td>18</td><td>OR</td><td>1680206C1</td></tr> </tbody> </table> </div> <p style="text-align: center;">CONNECTOR 3673259C1 BODY LOCK 3503599C1</p> <p style="text-align: right; font-size: x-small;">(* W/ LONESTAR)</p>						CAV	CIR	GAUGE	COLOR	TERMINAL	1	A67V	18	GY	1680206C1	2	A67W	18	GY	1680206C1	3	A67U	18	GY	1680206C1	4	A57NA	18	OR	1680206C1																				
CAV	CIR	GAUGE	COLOR	TERMINAL																																														
1	A67V	18	GY	1680206C1																																														
2	A67W	18	GY	1680206C1																																														
3	A67U	18	GY	1680206C1																																														
4	A57NA	18	OR	1680206C1																																														
<p style="text-align: center;">EATON VORAD DRIVER INTERFACE UNIT (1943) (LOCATED IN INSTRUMENT PANEL TO THE RIGHT OF STEERING COLUMN) (W/ PROSTAR)</p> <div style="display: flex; justify-content: space-around; align-items: center;">  <table border="1" style="font-size: x-small;"> <thead> <tr><th>CAV</th><th>CIR</th><th>GAUGE</th><th>COLOR</th><th>TERMINAL</th></tr> </thead> <tbody> <tr><td>1</td><td>-</td><td>-</td><td>-</td><td>-</td></tr> <tr><td>2</td><td>-</td><td>-</td><td>-</td><td>-</td></tr> <tr><td>3</td><td>-</td><td>-</td><td>-</td><td>-</td></tr> <tr><td>4</td><td>A67E</td><td>18</td><td>PK</td><td>3673333C1</td></tr> <tr><td>5</td><td>A67-GD</td><td>18</td><td>WH</td><td>3673333C1</td></tr> <tr><td>6</td><td>A5HA(-)</td><td>18</td><td>GN</td><td>3673333C1</td></tr> <tr><td>7</td><td>A5HA(+)</td><td>18</td><td>YL</td><td>3673333C1</td></tr> <tr><td>8</td><td>-</td><td>-</td><td>-</td><td>-</td></tr> </tbody> </table> </div> <p style="text-align: center;">CONNECTOR 3673333C1</p>						CAV	CIR	GAUGE	COLOR	TERMINAL	1	-	-	-	-	2	-	-	-	-	3	-	-	-	-	4	A67E	18	PK	3673333C1	5	A67-GD	18	WH	3673333C1	6	A5HA(-)	18	GN	3673333C1	7	A5HA(+)	18	YL	3673333C1	8	-	-	-	-
CAV	CIR	GAUGE	COLOR	TERMINAL																																														
1	-	-	-	-																																														
2	-	-	-	-																																														
3	-	-	-	-																																														
4	A67E	18	PK	3673333C1																																														
5	A67-GD	18	WH	3673333C1																																														
6	A5HA(-)	18	GN	3673333C1																																														
7	A5HA(+)	18	YL	3673333C1																																														
8	-	-	-	-																																														
<p style="text-align: center;">EATON VORAD DRIVER INTERFACE UNIT (1943M) (LOCATED IN INSTRUMENT PANEL TO THE RIGHT OF STEERING COLUMN) (W/ LONESTAR)</p> <div style="display: flex; justify-content: space-around; align-items: center;">  <table border="1" style="font-size: x-small;"> <thead> <tr><th>CAV</th><th>CIR</th><th>GAUGE</th><th>COLOR</th><th>TERMINAL</th></tr> </thead> <tbody> <tr><td>1</td><td>-</td><td>-</td><td>-</td><td>-</td></tr> <tr><td>2</td><td>-</td><td>-</td><td>-</td><td>-</td></tr> <tr><td>3</td><td>-</td><td>-</td><td>-</td><td>-</td></tr> <tr><td>4</td><td>A67E</td><td>18</td><td>PK</td><td>3673333C1</td></tr> <tr><td>5</td><td>A67-GD</td><td>18</td><td>WH</td><td>3673333C1</td></tr> <tr><td>6</td><td>A5HA(-)</td><td>18</td><td>GN</td><td>3673333C1</td></tr> <tr><td>7</td><td>A5HA(+)</td><td>18</td><td>YL</td><td>3673333C1</td></tr> <tr><td>8</td><td>-</td><td>-</td><td>-</td><td>-</td></tr> </tbody> </table> </div> <p style="text-align: center;">CONNECTOR 3673332C1</p>						CAV	CIR	GAUGE	COLOR	TERMINAL	1	-	-	-	-	2	-	-	-	-	3	-	-	-	-	4	A67E	18	PK	3673333C1	5	A67-GD	18	WH	3673333C1	6	A5HA(-)	18	GN	3673333C1	7	A5HA(+)	18	YL	3673333C1	8	-	-	-	-
CAV	CIR	GAUGE	COLOR	TERMINAL																																														
1	-	-	-	-																																														
2	-	-	-	-																																														
3	-	-	-	-																																														
4	A67E	18	PK	3673333C1																																														
5	A67-GD	18	WH	3673333C1																																														
6	A5HA(-)	18	GN	3673333C1																																														
7	A5HA(+)	18	YL	3673333C1																																														
8	-	-	-	-																																														
CHK	DATE	CHANGE	REV	REFERENCE	DRAWN	NAME																																												
CNA1	14JAN09	ADDED LONESTAR EFFECT	B	61254R	300152	CIRCUIT DIAGRAM, PROSTAR, LONESTAR																																												
					RELEASE NO.	DATE																																												
					50297W	18OCT07																																												
						PART NO.																																												
						AE08055906																																												
						SHEET																																												
						50A																																												

Figure 287 Connector Composites (1932), (1933), (1942/1942F), (1943), (1943M)

14.59. CONNECTOR COMPOSITES (1944), P. 50B

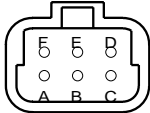
INTERNATIONAL TRUCK AND ENGINE CORPORATION <small>THIS PRINT IS PROVIDED ON A RESTRICTED BASIS AND IS NOT TO BE USED IN ANY WAY DETRIMENTAL TO THE INTEREST OF INTERNATIONAL TRUCK AND ENGINE CORPORATION.</small>	ELECTRICAL CIRCUIT DIAGRAM CHAPTER 14 CONNECTOR BODY COMPOSITE - MATING VIEW SHOWN																																																								
<div style="display: flex; justify-content: space-between;"> <div style="width: 45%;"> <p>WABCO ONGUARD DRIVER INTERFACE UNIT (1944) (LOCATED IN INSTRUMENT PANEL TO THE RIGHT OF STEERING COLUMN) (W/ PROSTAR)</p>  <p>CONNECTOR 2011340C1</p> </div> <div style="width: 45%;"> <table border="1" style="width: 100%; border-collapse: collapse; text-align: center;"> <thead> <tr> <th>CAV</th> <th>CIR</th> <th>GAUGE</th> <th>COLOR</th> <th>TERMINAL</th> </tr> </thead> <tbody> <tr> <td>A</td> <td>A5HA(+)</td> <td>18</td> <td>YL</td> <td>1661875C1</td> </tr> <tr> <td>B</td> <td>A5HA(-)</td> <td>18</td> <td>GN</td> <td>1661875C1</td> </tr> <tr> <td>C</td> <td>-</td> <td>-</td> <td>-</td> <td>-</td> </tr> <tr> <td>D</td> <td>A67-GM</td> <td>18</td> <td>WH</td> <td>1661875C1</td> </tr> <tr> <td>E</td> <td>A67EA</td> <td>18</td> <td>PK</td> <td>1661875C1</td> </tr> <tr> <td>F</td> <td>-</td> <td>-</td> <td>-</td> <td>-</td> </tr> </tbody> </table> </div> </div>		CAV	CIR	GAUGE	COLOR	TERMINAL	A	A5HA(+)	18	YL	1661875C1	B	A5HA(-)	18	GN	1661875C1	C	-	-	-	-	D	A67-GM	18	WH	1661875C1	E	A67EA	18	PK	1661875C1	F	-	-	-	-																					
CAV	CIR	GAUGE	COLOR	TERMINAL																																																					
A	A5HA(+)	18	YL	1661875C1																																																					
B	A5HA(-)	18	GN	1661875C1																																																					
C	-	-	-	-																																																					
D	A67-GM	18	WH	1661875C1																																																					
E	A67EA	18	PK	1661875C1																																																					
F	-	-	-	-																																																					
<table border="1" style="width: 100%; border-collapse: collapse; font-size: small;"> <tr> <th>CHK</th> <th>DATE</th> <th>CHANGE</th> <th>REV</th> <th>REFERENCE</th> <th>DRAWN</th> <th>NAME</th> </tr> <tr> <td>CNA1</td> <td>07OCT09</td> <td>INITIAL RELEASE</td> <td>A</td> <td>62556A</td> <td>U00W484</td> <td>CIRCUIT DIAGRAM, PROSTAR, LONESTAR</td> </tr> <tr> <td></td> <td></td> <td></td> <td></td> <td></td> <td>RELEASE NO.</td> <td>DATE</td> </tr> <tr> <td></td> <td></td> <td></td> <td></td> <td></td> <td>62556A</td> <td>10SEP09</td> </tr> <tr> <td></td> <td></td> <td></td> <td></td> <td></td> <td></td> <td>PART NO.</td> </tr> <tr> <td></td> <td></td> <td></td> <td></td> <td></td> <td></td> <td>AE08055906</td> </tr> <tr> <td></td> <td></td> <td></td> <td></td> <td></td> <td></td> <td>SHEET</td> </tr> <tr> <td></td> <td></td> <td></td> <td></td> <td></td> <td></td> <td>50B</td> </tr> </table>		CHK	DATE	CHANGE	REV	REFERENCE	DRAWN	NAME	CNA1	07OCT09	INITIAL RELEASE	A	62556A	U00W484	CIRCUIT DIAGRAM, PROSTAR, LONESTAR						RELEASE NO.	DATE						62556A	10SEP09							PART NO.							AE08055906							SHEET							50B
CHK	DATE	CHANGE	REV	REFERENCE	DRAWN	NAME																																																			
CNA1	07OCT09	INITIAL RELEASE	A	62556A	U00W484	CIRCUIT DIAGRAM, PROSTAR, LONESTAR																																																			
					RELEASE NO.	DATE																																																			
					62556A	10SEP09																																																			
						PART NO.																																																			
						AE08055906																																																			
						SHEET																																																			
						50B																																																			

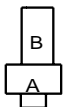
Figure 288 Connector Composites (1944)

14.60. CONNECTOR COMPOSITES (1953), (1960), P. 51

<p>INTERNATIONAL TRUCK AND ENGINE CORPORATION</p> <p>THIS PRINT IS PROVIDED ON A RESTRICTED BASIS AND IS NOT TO BE USED IN ANY WAY DETRIMENTAL TO THE INTEREST OF INTERNATIONAL TRUCK AND ENGINE CORPORATION.</p>	<p>ELECTRICAL CIRCUIT DIAGRAM CHAPTER 14</p> <p>CONNECTOR BODY COMPOSITE - MATING VIEW SHOWN</p>
---	--

JAKE BRAKE FOOT PEDAL  
(1953)  
(LOCATED IN INSTRUMENT PANEL - LEFT SIDE)  
(W/ LONESTAR)

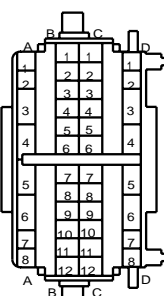


CONNECTOR 0872291R1

CAV	CIR	GAUGE	COLOR	TERMINAL
A	A9FS	18	GY	0879630R1
B	A24B	18	GY	0879630R1

MODULE BRACKET  
"B" CONNECTOR  
(1960)  
(LOCATED ON MODULE BRACKET)



CONNECTOR 3553649C1  
BODY LOCK 3553652C1  
3553654C1  
3553650C1

CAV	CIR	GAUGE	COLOR	TERMINAL
A1	A67E	16	GY	3544884C1
A2	A67D	16	GY	3544884C1
A3	A67A	16	GY	3544876C1
A4	A67-G	16	WH	3544876C1
A5	A57NA	18	OR	3544876C1
A5#	A57NA	16	OR	3544876C1
A6	A98ZA	18	BK	3544876C1
A7	A67C	16	GY	3544884C1
A8	A67B	16	GY	3544884C1
B1	A3BF(+)	20	DKBL	3544883C1
B2	A3BF(-)	20	GY	3544883C1
B3	A67KA	16	GY	3544884C1
B4	A67J	16	GY	3544884C1
B5	A67HA	16	GY	3544884C1
B6	A67L	16	GY	3544884C1
B7	A67M	18	GY	3544884C1
B8	A67N	18	GY	3544884C1
B9	A67P	18	GY	3544884C1
B10	A67R	18	GY	3544884C1
B11	A5HA(+)	18	YL	3544884C1
B12	A5HA(-)	18	GN	3544884C1
C1	A3BN(+)	18	DKBL	3544884C1
C2	A3BN(-)	18	GY	3544884C1
C3	A98NS	18	BK	3544884C1
C4	AOUT2	18	TN	3544884C1
C5	A5VREF	18	TN	3544884C1
C6	APPU	18	TN	3544884C1
C7	AANG1	18	TN	3544884C1
C8	AANG2	18	TN	3544884C1
C9	AANG3	18	TN	3544884C1
C10	AANG4	18	TN	3544884C1
C11	AANG5	18	TN	3544884C1
C12	AANG-G	18	GY	3544884C1
D1	A98Z	18	BK	3544884C1
D2	A98NL	18	BK	3544884C1
D3	A14NN	18	RD	3544876C1
D4	A13N	18	PK	3544876C1
D5	A11-GNA	18	WH	3544876C1
D6	A14NP	16	RD	3544876C1
D7	A5K(+)	18	YL	3544884C1
D8	A5K(-)	18	GN	3544884C1

# W/ LONESTAR

CHK	DATE	CHANGE	REV	REFERENCE	DRAWN	NAME
CNA1	14JAN09	ADDED LONESTAR EFFECT	A	61254R	U00K640	CIRCUIT DIAGRAM, PROSTAR, LONESTAR
					59637L	DATE: 06SEP06 PART NO: AE08055906 SHEET: 051

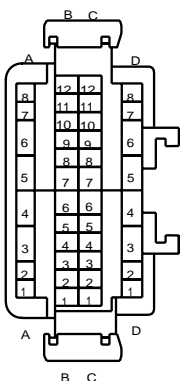
Figure 289 Connector Composites (1953), (1960)

14.61. CONNECTOR COMPOSITES (1960), P. 52

<p>INTERNATIONAL TRUCK AND ENGINE CORPORATION</p> <p>THIS PRINT IS PROVIDED ON A RESTRICTED BASIS AND IS NOT TO BE USED IN ANY WAY DETRIMENTAL TO THE INTEREST OF INTERNATIONAL TRUCK AND ENGINE CORPORATION.</p>	<p>ELECTRICAL CIRCUIT DIAGRAM CHAPTER 14</p> <p>CONNECTOR BODY COMPOSITE - MATING VIEW SHOWN</p>
---	--

IP HARNESS INTERCONNECT  
(1960)  
(LOCATED ON MODULE BRACKET)



CONNECTOR 3612512C1  
BODY LOCK 3553652C1  
3553654C1

CAV	CIR	GAUGE	COLOR	TERMINAL
A1	A67E	16	GY	3544886C1
A2	A67D	16	GY	3544886C1
A3	A67A	16	GY	3544880C1
A4	A67-G	18	WH	3544880C1
A5	A67F	18	GY	3544880C1
A6	-	-	-	-
A7	A67C	18	GY	3544886C1
A8	A67B	16	GY	3544886C1
B1	A3BF(+)	18	DKBL	3544886C1
B2	A3BF(-)	18	GY	3544886C1
B3	A67KA	16	GY	3544886C1
B4	A67J	16	GY	3544886C1
B5	A67HA	16	GY	3544886C1
B6	A67L	18	GY	3544886C1
B7	A67M	18	GY	3544886C1
B8	A67N	18	GY	3544886C1
B9	A67P	18	GY	3544886C1
B10	A67R	18	GY	3544886C1
B11	A5HA(+)	18	YL	3544886C1
B12	A5HA(-)	18	GN	3544886C1
C1*	A3BN(+)	18	DKBL	3544886C1
C1#	A3BN(+)	20	DKBL	3544885C1
C2*	A3BN(-)	18	GY	3544886C1
C2#	A3BN(-)	20	GY	3544885C1
C3*	A98NS	18	BK	3544886C1
C3#	A91AC	20	BK	3544885C1
C4	-	-	-	-
C5	-	-	-	-
C6	-	-	-	-
C7	-	-	-	-
C8	-	-	-	-
C9	-	-	-	-
C10	-	-	-	-
C11	-	-	-	-
C12	-	-	-	-
D1*	A98Z	18	BK	3544886C1
D1#	A91AA	20	BK	3544885C1
D2*	A98NI	18	A14NN	3544886C1
D2#	A91AB	20	GY	3544885C1
D3*	A14NN	18	RD	3544880C1
D3#	A14NN	20	RD	3544879C1
D4	A13N	18	PK	3544880C1
D5*	A11-GNA	18	WH	3544880C1
D5#	A98NI	18	BK	3544880C1
D6	-	-	-	-
D7	A5K(+)	18	YL	3544886C1
D8	A5K(-)	18	GN	3544886C1

\* W/ TELEMATICS GEN I  
# W/ AWARE II

CHK	DATE	CHANGE	REV	REFERENCE	DRAWN	NAME
CNA1	14JAN09	TITLE WAS CIRCUIT	B	61254R	U00K640	CIRCUIT DIAGRAM, PROSTAR, LONESTAR
		DIAGRAM, PROSTAR			59637L	DATE: 06SEP06 PART NO: AE08055906 SHEET: 052

Figure 290 Connector Composites (1960)

14.62. CONNECTOR COMPOSITES (1962), P. 53

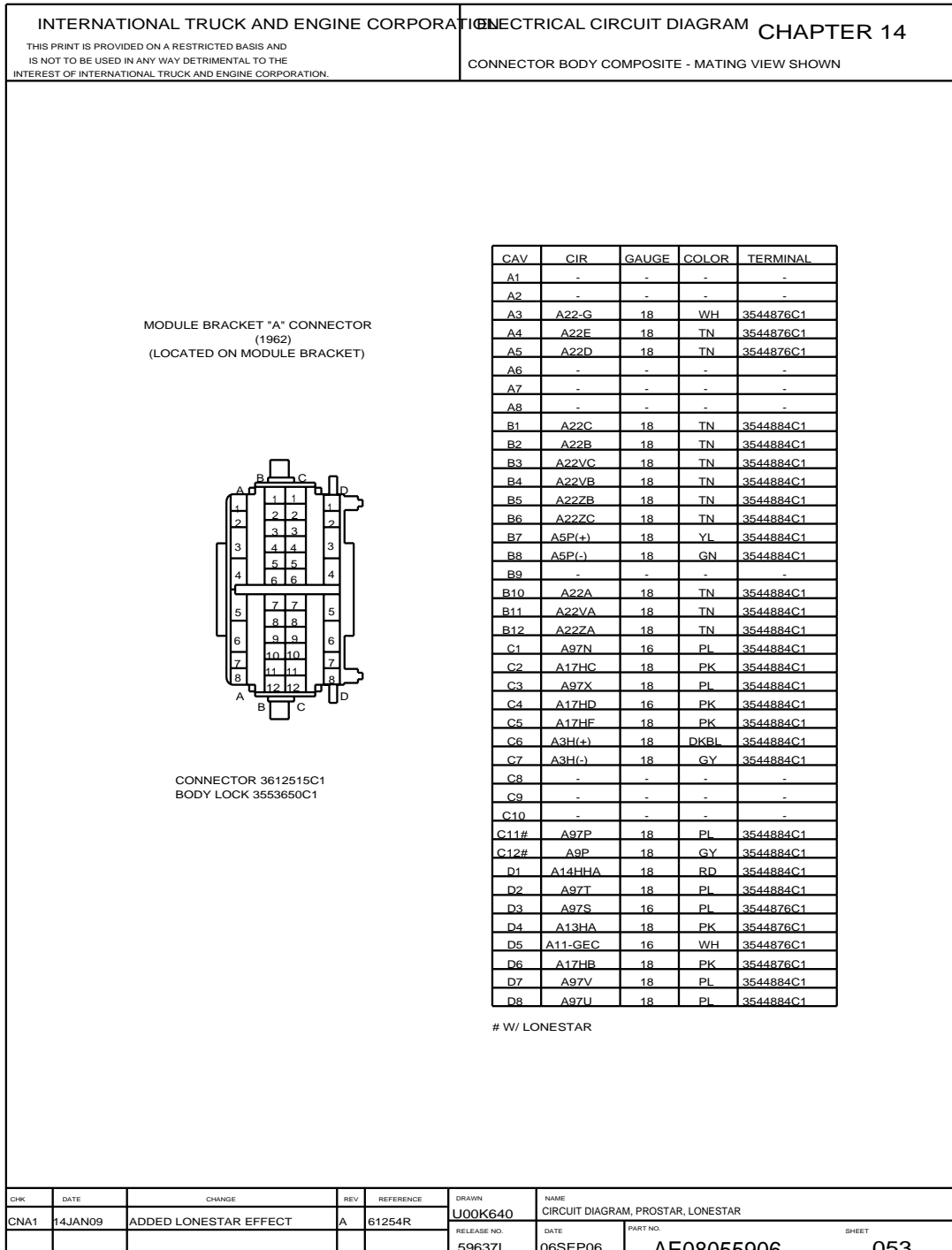


Figure 291 Connector Composites (1962)

14.63. CONNECTOR COMPOSITES (1962), P. 54

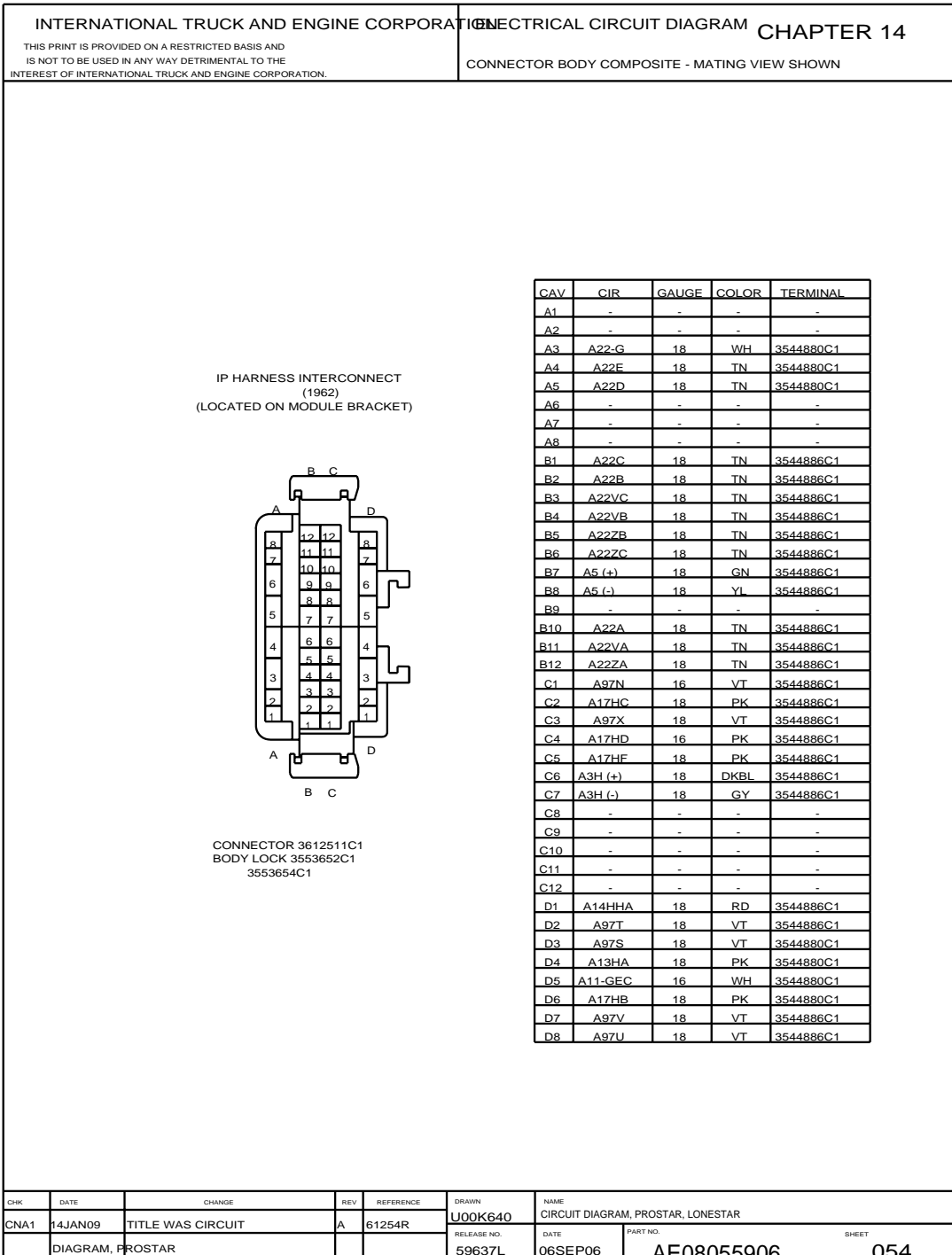


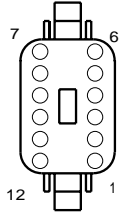
Figure 292 Connector Composites (1962)

14.64. CONNECTOR COMPOSITES (1963), (1964), P. 55

<p>INTERNATIONAL TRUCK AND ENGINE CORPORATION</p> <p><small>THIS PRINT IS PROVIDED ON A RESTRICTED BASIS AND IS NOT TO BE USED IN ANY WAY DETRIMENTAL TO THE INTEREST OF INTERNATIONAL TRUCK AND ENGINE CORPORATION.</small></p>	<p>ELECTRICAL CIRCUIT DIAGRAM CHAPTER 14</p> <p>CONNECTOR BODY COMPOSITE - MATING VIEW SHOWN</p>
--	--

TELEMATICS CONNECTOR 1  
(1963)  
(LOCATED ON MODULE BRACKET)  
(W/ PROSTAR)

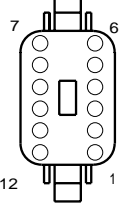


CONNECTOR 3601924C1  
BODY LOCK 1689428C1

CAV	CIR	GAUGE	COLOR	TERMINAL
1	A14NN	18	RD	1680205C1
2	PLUG	-	-	0453133C1
3	A13N	18	PK	1680205C1
4	PLUG	-	-	0453133C1
5	A98NL	18	BK	1680205C1
6	PLUG	-	-	0453133C1
7	PLUG	-	-	0453133C1
8	PLUG	-	-	0453133C1
9	A5K(+)	18	YL	1680205C1
10	A5K(-)	18	GN	1680205C1
11	A98Z	18	BK	1680205C1
12	A11-GNA	18	WH	1680205C1

TELEMATICS CONNECTOR 2  
(1964)  
(LOCATED ON MODULE BRACKET)  
(W/ PROSTAR)



CONNECTOR 1689427C1  
BODY LOCK 1689428C1

CAV	CIR	GAUGE	COLOR	TERMINAL
1	A3BN(+)	18	DKBL	1680205C1
2	A3BN(-)	18	GY	1680205C1
3	PLUG	-	-	0453133C1
4	PLUG	-	-	0453133C1
5	PLUG	-	-	0453133C1
6	A98NS	18	BK	1680205C1
7	PLUG	-	-	0453133C1
8	PLUG	-	-	0453133C1
9	PLUG	-	-	0453133C1
10	PLUG	-	-	0453133C1
11	PLUG	-	-	0453133C1
12	PLUG	-	-	0453133C1

CHK	DATE	CHANGE	REV	REFERENCE	DRAWN	NAME
CNA1	14JAN09	TITLE WAS CIRCUIT	A	61254R	U00K640	CIRCUIT DIAGRAM, PROSTAR, LONESTAR
		DIAGRAM, PROSTAR			59637L	DATE: 06SEP06 PART NO: AE08055906 SHEET: 055

Figure 293 Connector Composites (1963), (1964)

14.65. CONNECTOR COMPOSITES (1970), (1973), P. 56

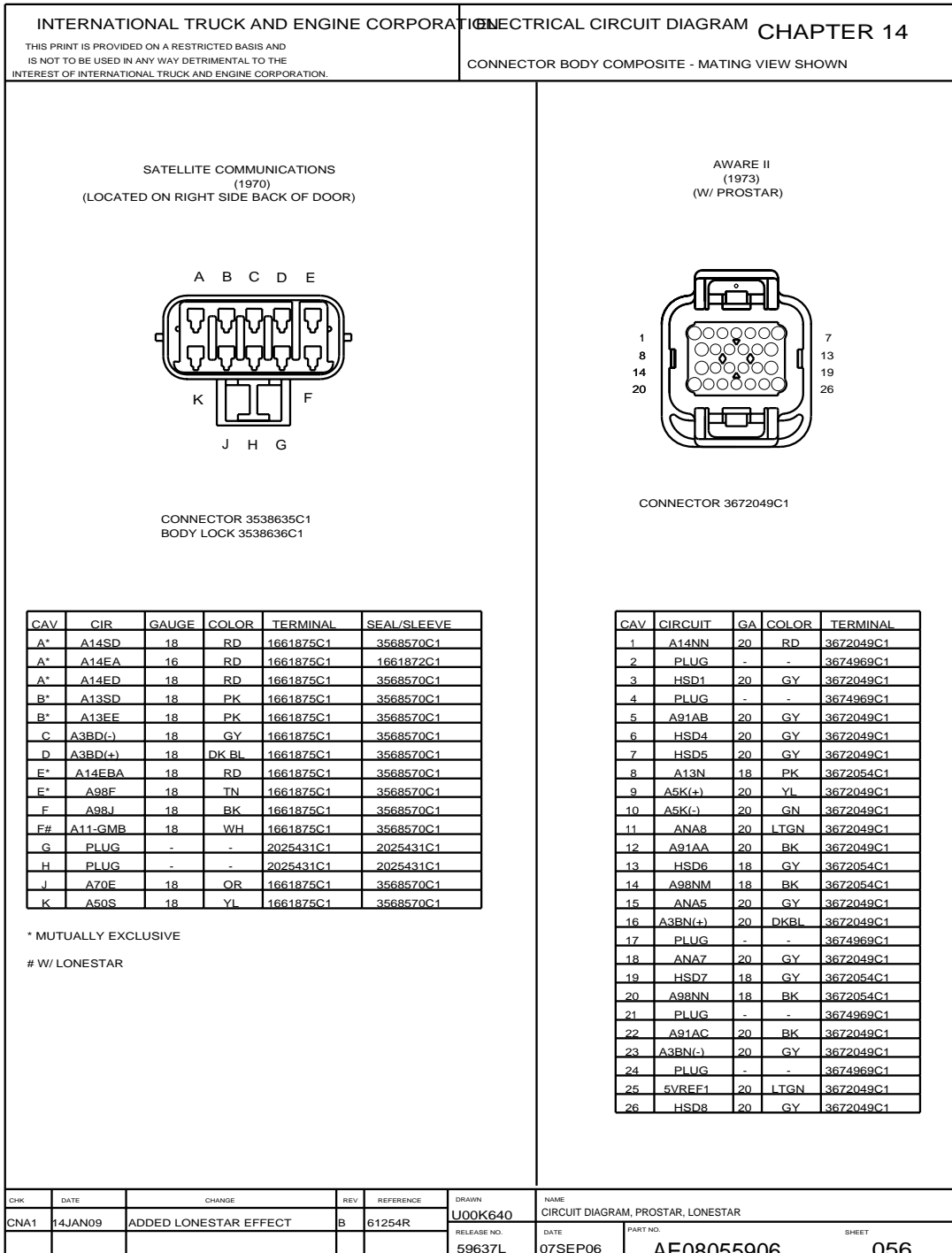


Figure 294 Connector Composites (1970), (1973)

14.66. CONNECTOR COMPOSITES (1974), (1975), P. 56A

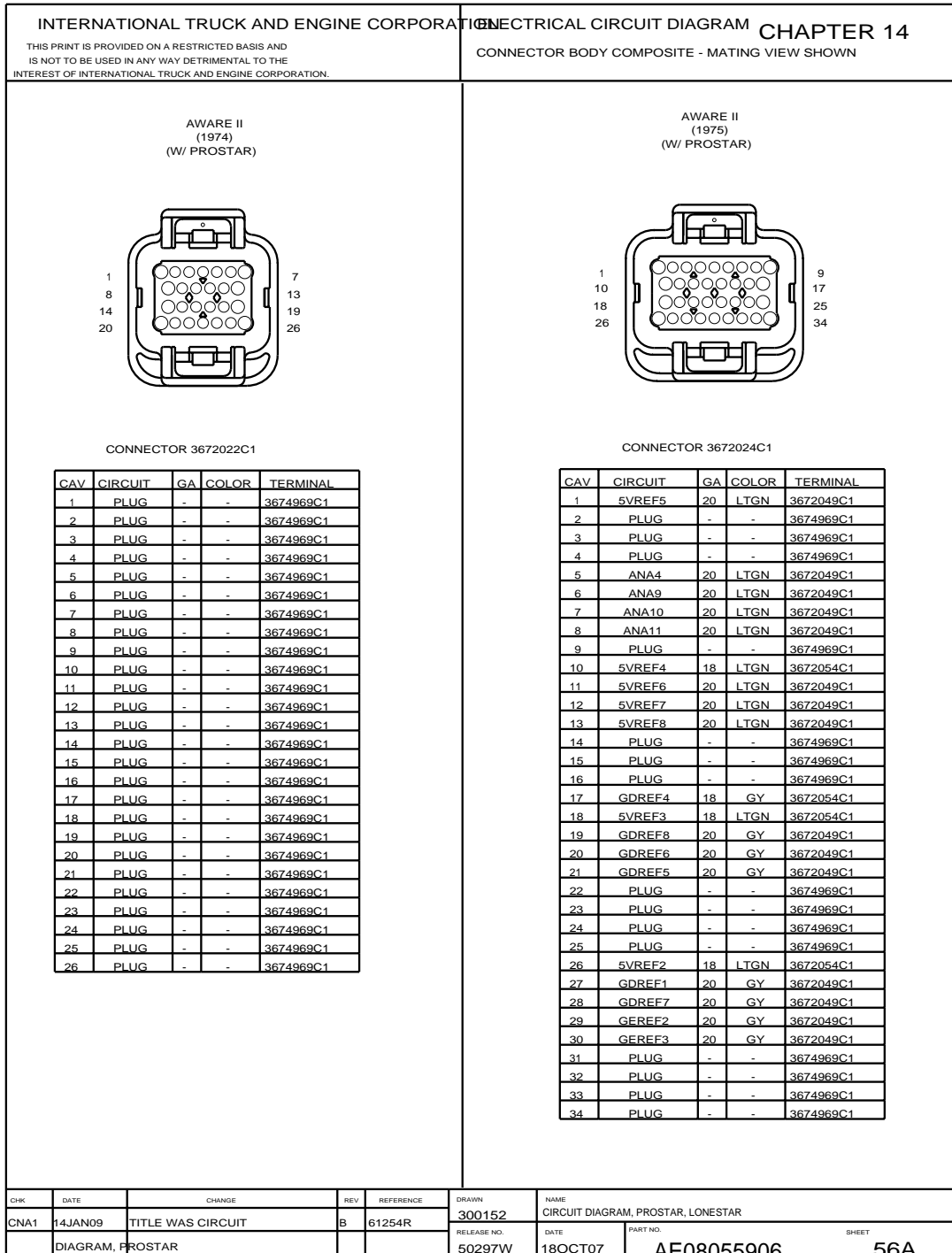


Figure 295 Connector Composites (1974), (1975)

14.67. CONNECTOR COMPOSITES (2000), P. 56B

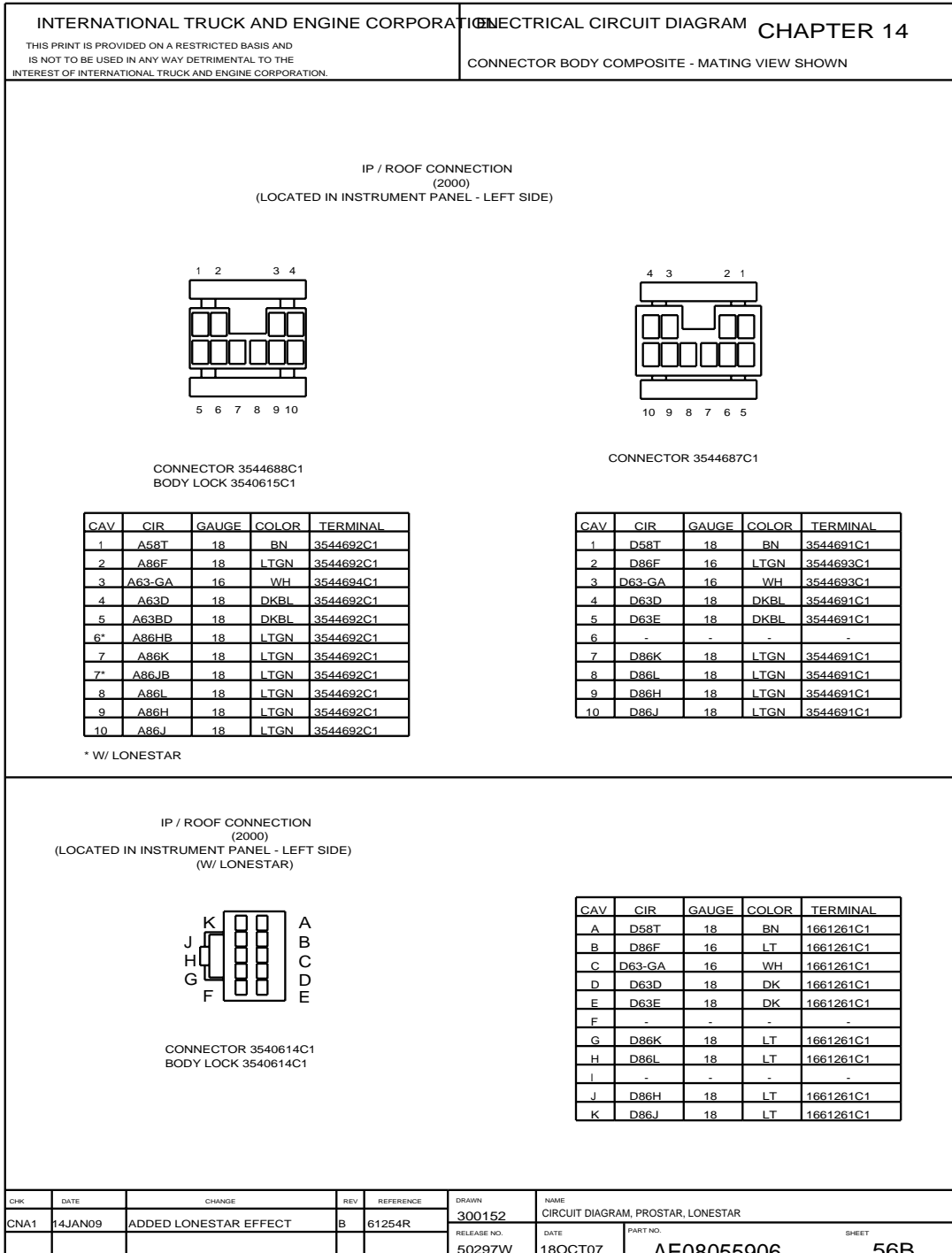








Figure 296 Connector Composites (2000)

**14.68. CONNECTOR COMPOSITES (2002M), (2003M), (2004M), (2005M), (2006M), (2007F), P. 57**

INTERNATIONAL TRUCK AND ENGINE CORPORATION				ELECTRICAL CIRCUIT DIAGRAM CHAPTER 14																		
THIS PRINT IS PROVIDED ON A RESTRICTED BASIS AND IS NOT TO BE USED IN ANY WAY DETRIMENTAL TO THE INTEREST OF INTERNATIONAL TRUCK AND ENGINE CORPORATION.				CONNECTOR BODY COMPOSITE - MATING VIEW SHOWN																		
<p>LEFT CLEARANCE (2002M) (LOCATED IN FRONT ROOF) (W/ PROSTAR)</p>  <p>CONNECTOR 1661259C1 BODY LOCK 1661263C1</p>				<table border="1"> <thead> <tr> <th>CAV</th> <th>CIR</th> <th>GAUGE</th> <th>COLOR</th> <th>TERMINAL</th> </tr> </thead> <tbody> <tr> <td>A</td> <td>D58Z</td> <td>18</td> <td>BN</td> <td>1661261C1</td> </tr> <tr> <td>B</td> <td>D58-GD</td> <td>18</td> <td>WH</td> <td>1661261C1</td> </tr> </tbody> </table>				CAV	CIR	GAUGE	COLOR	TERMINAL	A	D58Z	18	BN	1661261C1	B	D58-GD	18	WH	1661261C1
CAV	CIR	GAUGE	COLOR	TERMINAL																		
A	D58Z	18	BN	1661261C1																		
B	D58-GD	18	WH	1661261C1																		
<p>LEFT MARKER (2003M) (LOCATED IN FRONT ROOF) (W/ PROSTAR)</p>  <p>CONNECTOR 1661259C1 BODY LOCK 1661263C1</p>				<table border="1"> <thead> <tr> <th>CAV</th> <th>CIR</th> <th>GAUGE</th> <th>COLOR</th> <th>TERMINAL</th> </tr> </thead> <tbody> <tr> <td>A</td> <td>D58M</td> <td>18</td> <td>BN</td> <td>1661261C1</td> </tr> <tr> <td>B</td> <td>D58-GE</td> <td>18</td> <td>WH</td> <td>1661261C1</td> </tr> </tbody> </table>				CAV	CIR	GAUGE	COLOR	TERMINAL	A	D58M	18	BN	1661261C1	B	D58-GE	18	WH	1661261C1
CAV	CIR	GAUGE	COLOR	TERMINAL																		
A	D58M	18	BN	1661261C1																		
B	D58-GE	18	WH	1661261C1																		
<p>MID MARKER (2004M) (LOCATED IN FRONT ROOF) (W/ PROSTAR)</p>  <p>CONNECTOR 1661259C1 BODY LOCK 1661263C1</p>				<table border="1"> <thead> <tr> <th>CAV</th> <th>CIR</th> <th>GAUGE</th> <th>COLOR</th> <th>TERMINAL</th> </tr> </thead> <tbody> <tr> <td>A</td> <td>D58N</td> <td>18</td> <td>BN</td> <td>1661261C1</td> </tr> <tr> <td>B</td> <td>D58-GF</td> <td>18</td> <td>WH</td> <td>1661261C1</td> </tr> </tbody> </table>				CAV	CIR	GAUGE	COLOR	TERMINAL	A	D58N	18	BN	1661261C1	B	D58-GF	18	WH	1661261C1
CAV	CIR	GAUGE	COLOR	TERMINAL																		
A	D58N	18	BN	1661261C1																		
B	D58-GF	18	WH	1661261C1																		
<p>RIGHT MARKER (2005M) (LOCATED IN FRONT ROOF) (W/ PROSTAR)</p>  <p>CONNECTOR 1661259C1 BODY LOCK 1661263C1</p>				<table border="1"> <thead> <tr> <th>CAV</th> <th>CIR</th> <th>GAUGE</th> <th>COLOR</th> <th>TERMINAL</th> </tr> </thead> <tbody> <tr> <td>A</td> <td>D58P</td> <td>18</td> <td>BN</td> <td>1661261C1</td> </tr> <tr> <td>B</td> <td>D58-GH</td> <td>18</td> <td>WH</td> <td>1661261C1</td> </tr> </tbody> </table>				CAV	CIR	GAUGE	COLOR	TERMINAL	A	D58P	18	BN	1661261C1	B	D58-GH	18	WH	1661261C1
CAV	CIR	GAUGE	COLOR	TERMINAL																		
A	D58P	18	BN	1661261C1																		
B	D58-GH	18	WH	1661261C1																		
<p>RIGHT CLEARANCE (2006M) (LOCATED IN FRONT ROOF) (W/ PROSTAR)</p>  <p>CONNECTOR 1661259C1 BODY LOCK 1661263C1</p>				<table border="1"> <thead> <tr> <th>CAV</th> <th>CIR</th> <th>GAUGE</th> <th>COLOR</th> <th>TERMINAL</th> </tr> </thead> <tbody> <tr> <td>A</td> <td>D58R</td> <td>18</td> <td>BN</td> <td>1661261C1</td> </tr> <tr> <td>B</td> <td>D58-GJ</td> <td>18</td> <td>WH</td> <td>1661261C1</td> </tr> </tbody> </table>				CAV	CIR	GAUGE	COLOR	TERMINAL	A	D58R	18	BN	1661261C1	B	D58-GJ	18	WH	1661261C1
CAV	CIR	GAUGE	COLOR	TERMINAL																		
A	D58R	18	BN	1661261C1																		
B	D58-GJ	18	WH	1661261C1																		
<p>SUNSHADE (2007F) (LOCATED AT SUNSHADE) (W/ LONESTAR)</p>  <p>CONNECTOR 1661260C1 BODY LOCK 1661264C1</p>				<table border="1"> <thead> <tr> <th>CAV</th> <th>CIR</th> <th>GAUGE</th> <th>COLOR</th> <th>TERMINAL</th> </tr> </thead> <tbody> <tr> <td>A</td> <td>D58T</td> <td>18</td> <td>BN</td> <td>1661262C1</td> </tr> <tr> <td>B</td> <td>D58-GL</td> <td>18</td> <td>WH</td> <td>1661262C1</td> </tr> </tbody> </table>				CAV	CIR	GAUGE	COLOR	TERMINAL	A	D58T	18	BN	1661262C1	B	D58-GL	18	WH	1661262C1
CAV	CIR	GAUGE	COLOR	TERMINAL																		
A	D58T	18	BN	1661262C1																		
B	D58-GL	18	WH	1661262C1																		
CHK	DATE	CHANGE	REV	REFERENCE	DRAWN	NAME																
CNA1	20JAN09	ADDED LONESTAR EFFECT	A	61254R	U00K640	CIRCUIT DIAGRAM, PROSTAR, LONESTAR																
					RELEASE NO.	DATE	PART NO.															
					59637L	07SEP06	AE08055906															
							SHEET 057															

**Figure 297 Connector Composites (2002M), (2003M), (2004M), (2005M), (2006M), (2007F)**

14.69. CONNECTOR COMPOSITES (2100), (2101), (2102), (2103), P. 58


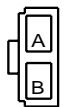

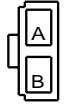

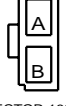

INTERNATIONAL TRUCK AND ENGINE CORPORATION		ELECTRICAL CIRCUIT DIAGRAM		CHAPTER 14																																				
THIS PRINT IS PROVIDED ON A RESTRICTED BASIS AND IS NOT TO BE USED IN ANY WAY DETRIMENTAL TO THE INTEREST OF INTERNATIONAL TRUCK AND ENGINE CORPORATION.		CONNECTOR BODY COMPOSITE - MATING VIEW SHOWN																																						
HEADLINER TO DOME LIGHT (2100) (LOCATED IN CAB ROOF) (W/ PROSTAR)  CONNECTOR 1661198C1		<table border="1" style="width:100%; border-collapse: collapse; font-size: x-small;"> <thead> <tr> <th>CAV</th> <th>CIR</th> <th>GAUGE</th> <th>COLOR</th> <th>TERMINAL</th> </tr> </thead> <tbody> <tr> <td>A</td> <td>C63-GE</td> <td>18</td> <td>WH</td> <td>1661261C1</td> </tr> <tr> <td>B</td> <td>C63D</td> <td>18</td> <td>DKBL</td> <td>1661261C1</td> </tr> <tr> <td>C</td> <td>C63E</td> <td>18</td> <td>DKBL</td> <td>1661261C1</td> </tr> </tbody> </table>				CAV	CIR	GAUGE	COLOR	TERMINAL	A	C63-GE	18	WH	1661261C1	B	C63D	18	DKBL	1661261C1	C	C63E	18	DKBL	1661261C1															
CAV	CIR	GAUGE	COLOR	TERMINAL																																				
A	C63-GE	18	WH	1661261C1																																				
B	C63D	18	DKBL	1661261C1																																				
C	C63E	18	DKBL	1661261C1																																				
HEADLINER TO ROOF HARNESS (2101) (LOCATED IN CAB ROOF FRONT) (W/ PROSTAR)  CONNECTOR 1669972C1		<table border="1" style="width:100%; border-collapse: collapse; font-size: x-small;"> <thead> <tr> <th>CAV</th> <th>CIR</th> <th>GAUGE</th> <th>COLOR</th> <th>TERMINAL</th> </tr> </thead> <tbody> <tr> <td>A#</td> <td>D63L</td> <td>18</td> <td>BL</td> <td>1661212C1</td> </tr> <tr> <td>A**</td> <td>D63D</td> <td>18</td> <td>DKBL</td> <td>1661208C1</td> </tr> <tr> <td>A*</td> <td>D63-GM</td> <td>18</td> <td>DKBL</td> <td>1661208C1</td> </tr> <tr> <td>B#</td> <td>D63L-G</td> <td>18</td> <td>WH</td> <td>1661212C1</td> </tr> <tr> <td>B*</td> <td>D63-GM</td> <td>18</td> <td>WH</td> <td>1661208C1</td> </tr> <tr> <td>B**</td> <td>D63-GM</td> <td>18</td> <td>DKBL</td> <td>1661208C1</td> </tr> </tbody> </table> <p style="font-size: x-small;"># W/ DOME LIGHT * W/ SLEEPER ** W/ SLEEPER-2</p>				CAV	CIR	GAUGE	COLOR	TERMINAL	A#	D63L	18	BL	1661212C1	A**	D63D	18	DKBL	1661208C1	A*	D63-GM	18	DKBL	1661208C1	B#	D63L-G	18	WH	1661212C1	B*	D63-GM	18	WH	1661208C1	B**	D63-GM	18	DKBL	1661208C1
CAV	CIR	GAUGE	COLOR	TERMINAL																																				
A#	D63L	18	BL	1661212C1																																				
A**	D63D	18	DKBL	1661208C1																																				
A*	D63-GM	18	DKBL	1661208C1																																				
B#	D63L-G	18	WH	1661212C1																																				
B*	D63-GM	18	WH	1661208C1																																				
B**	D63-GM	18	DKBL	1661208C1																																				
ROOF / DOME LIGHT CONNECTION (2101) (LOCATED IN CAB ROOF FRONT) (W/ LONESTAR)  CONNECTOR 1661260C1 BODY LOCK 1661264C1		<table border="1" style="width:100%; border-collapse: collapse; font-size: x-small;"> <thead> <tr> <th>CAV</th> <th>CIR</th> <th>GAUGE</th> <th>COLOR</th> <th>TERMINAL</th> </tr> </thead> <tbody> <tr> <td>A</td> <td>D63D</td> <td>18</td> <td>DK</td> <td>1661262C1</td> </tr> <tr> <td>B</td> <td>D63-GM</td> <td>18</td> <td>WH</td> <td>1661262C1</td> </tr> </tbody> </table>				CAV	CIR	GAUGE	COLOR	TERMINAL	A	D63D	18	DK	1661262C1	B	D63-GM	18	WH	1661262C1																				
CAV	CIR	GAUGE	COLOR	TERMINAL																																				
A	D63D	18	DK	1661262C1																																				
B	D63-GM	18	WH	1661262C1																																				
MAP / READING LIGHT (2102) (LOCATED IN CAB ROOF) (W/ PROSTAR)  CONNECTOR 1669972C1		MAP / READING LIGHT (2102) (LOCATED IN CAB ROOF) (W/ LONESTAR)  CONNECTOR 1669973C1																																						
<table border="1" style="width:100%; border-collapse: collapse; font-size: x-small;"> <thead> <tr> <th>CAV</th> <th>CIR</th> <th>GAUGE</th> <th>COLOR</th> <th>TERMINAL</th> </tr> </thead> <tbody> <tr> <td>A</td> <td>D63M</td> <td>18</td> <td>DKBL</td> <td>1661208C1</td> </tr> <tr> <td>B</td> <td>D63-GF</td> <td>18</td> <td>WH</td> <td>1661208C1</td> </tr> </tbody> </table>		CAV	CIR	GAUGE	COLOR	TERMINAL	A	D63M	18	DKBL	1661208C1	B	D63-GF	18	WH	1661208C1	<table border="1" style="width:100%; border-collapse: collapse; font-size: x-small;"> <thead> <tr> <th>CAV</th> <th>CIR</th> <th>GAUGE</th> <th>COLOR</th> <th>TERMINAL</th> </tr> </thead> <tbody> <tr> <td>A</td> <td>D63M</td> <td>18</td> <td>DK</td> <td>1661212C1</td> </tr> <tr> <td>B</td> <td>D63-GF</td> <td>18</td> <td>WH</td> <td>1661212C1</td> </tr> </tbody> </table>				CAV	CIR	GAUGE	COLOR	TERMINAL	A	D63M	18	DK	1661212C1	B	D63-GF	18	WH	1661212C1					
CAV	CIR	GAUGE	COLOR	TERMINAL																																				
A	D63M	18	DKBL	1661208C1																																				
B	D63-GF	18	WH	1661208C1																																				
CAV	CIR	GAUGE	COLOR	TERMINAL																																				
A	D63M	18	DK	1661212C1																																				
B	D63-GF	18	WH	1661212C1																																				
MAP / READING LIGHT (2103) (LOCATED IN CAB ROOF) (W/ PROSTAR)  CONNECTOR 1669972C1		MAP / READING LIGHT (2103) (LOCATED IN CAB ROOF) (W/ LONESTAR)  CONNECTOR 1669973C1																																						
<table border="1" style="width:100%; border-collapse: collapse; font-size: x-small;"> <thead> <tr> <th>CAV</th> <th>CIR</th> <th>GAUGE</th> <th>COLOR</th> <th>TERMINAL</th> </tr> </thead> <tbody> <tr> <td>A</td> <td>D63C</td> <td>18</td> <td>DKBL</td> <td>1661208C1</td> </tr> <tr> <td>B</td> <td>D63-GE</td> <td>18</td> <td>WH</td> <td>1661208C1</td> </tr> </tbody> </table>		CAV	CIR	GAUGE	COLOR	TERMINAL	A	D63C	18	DKBL	1661208C1	B	D63-GE	18	WH	1661208C1	<table border="1" style="width:100%; border-collapse: collapse; font-size: x-small;"> <thead> <tr> <th>CAV</th> <th>CIR</th> <th>GAUGE</th> <th>COLOR</th> <th>TERMINAL</th> </tr> </thead> <tbody> <tr> <td>A</td> <td>D63C</td> <td>18</td> <td>DK</td> <td>1661212C1</td> </tr> <tr> <td>B</td> <td>D63-GE</td> <td>18</td> <td>WH</td> <td>1661212C1</td> </tr> </tbody> </table>				CAV	CIR	GAUGE	COLOR	TERMINAL	A	D63C	18	DK	1661212C1	B	D63-GE	18	WH	1661212C1					
CAV	CIR	GAUGE	COLOR	TERMINAL																																				
A	D63C	18	DKBL	1661208C1																																				
B	D63-GE	18	WH	1661208C1																																				
CAV	CIR	GAUGE	COLOR	TERMINAL																																				
A	D63C	18	DK	1661212C1																																				
B	D63-GE	18	WH	1661212C1																																				
CHK	DATE	CHANGE	REV	REFERENCE	DRAWN	NAME																																		
CNA1	14JAN09	ADDED LONESTAR EFFECT	A	61254R	U00K640	CIRCUIT DIAGRAM, PROSTAR, LONESTAR																																		
					RELEASE NO.	DATE																																		
					59637L	07SEP06																																		
						PART NO.																																		
						AE08055906																																		
						SHEET																																		
						058																																		

Figure 298 Connector Composites (2100), (2101), (2102), (2103)

14.70. CONNECTOR COMPOSITES (2200), (2201), P. 59

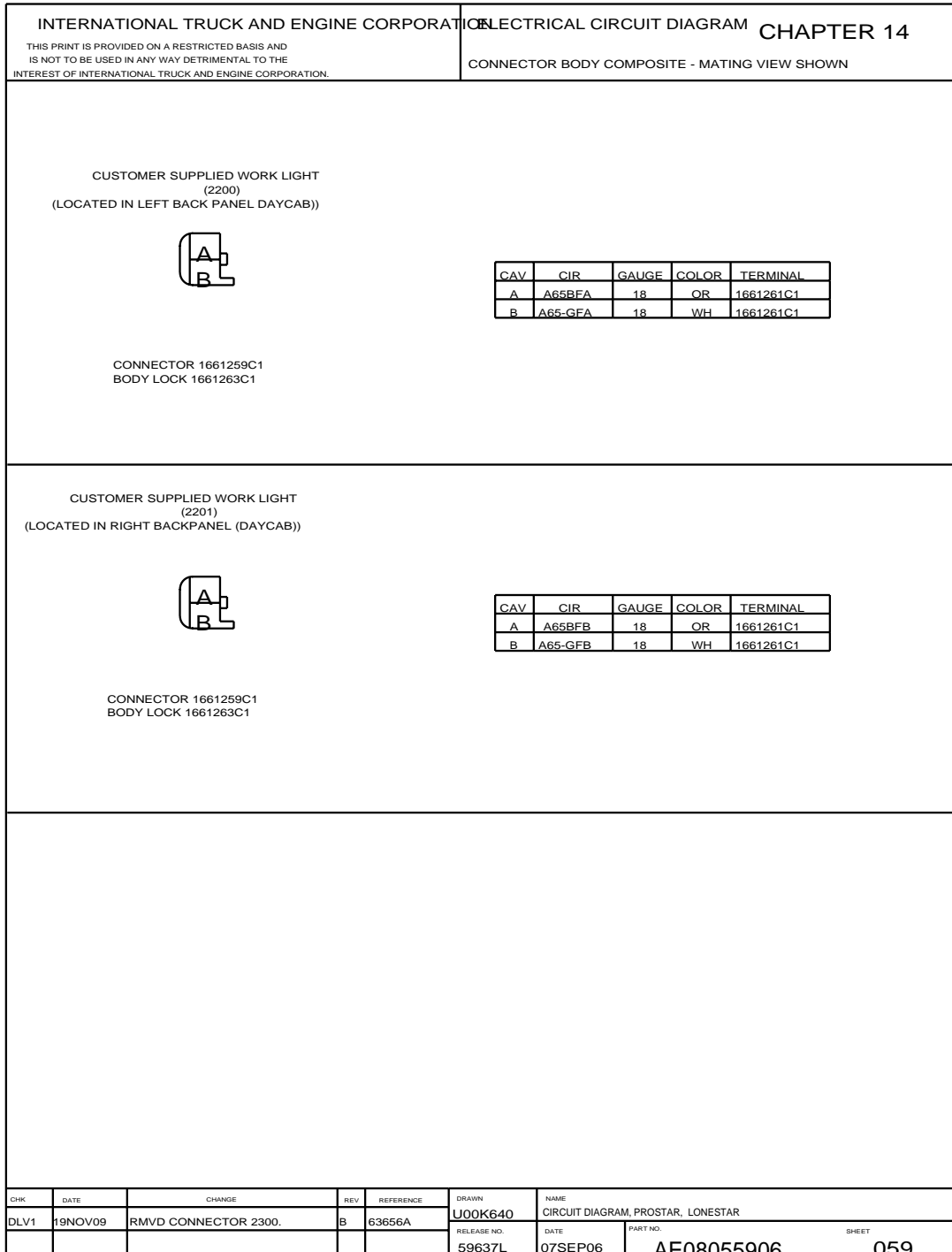


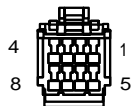
Figure 299 Connector Composites (2200), (2201)

14.71. CONNECTOR COMPOSITES (2224), (2225), (2227), P. 59A

INTERNATIONAL TRUCK AND ENGINE CORPORATION		ELECTRICAL CIRCUIT DIAGRAM		CHAPTER 14	
THIS PRINT IS PROVIDED ON A RESTRICTED BASIS AND IS NOT TO BE USED IN ANY WAY DETRIMENTAL TO THE INTEREST OF INTERNATIONAL TRUCK AND ENGINE CORPORATION.		CONNECTOR BODY COMPOSITE - MATING VIEW SHOWN			

DRIVER DISPLAY POWER  
(2224)  
(LOCATED IN INSTRUMENT PANEL CENTER)




CONNECTOR - 3833917C1  
BODY LOCK - N/A

CAV	CIR	GAUGE	COLOR	TERMINAL
1	A14A	12	RD	3535805C1
2	A10AA	20	WH	3535805C1
3	A12B	18	LTBL	3535805C1
4	-	-	-	-
5	A10AB	20	WH	3535805C1
6	A86A(+)	20	YL	3535805C1
7	A86A(-)	20	GN	3535805C1
8	-	-	-	-

DRIVER DISPLAY IO/MIC  
(2225)  
(LOCATED IN INSTRUMENT PANEL CENTER)

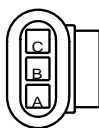


CONNECTOR - 3834322C1  
BODY LOCK - N/A

CAV	CIR	GAUGE	COLOR	TERMINAL
1	A9A	20	WH	3835322C1
2	-	-	-	-
3	-	-	-	-
4	-	-	-	-
5	-	-	-	-
6	-	-	-	-
7	-	-	-	-
8	A5L(+)	20	YL	3835322C1
9	-	-	-	-
10	A10AC	20	WH	3835322C1
11	A86AA	20	LTGN	3835322C1
12	A86AB	20	LTGN	3835322C1
13	A86AC	20	LTGN	3835322C1
14	A86AD	20	LTGN	3835322C1
15	A10AD	20	WH	3835322C1
16	A5L(-)	20	GN	3835322C1

DRIVER DISPLAY J1939 RESISTOR  
(2227)  
(LOCATED IN INSTRUMENT PANEL CENTER)



CONNECTOR 1667741C1  
BODY LOCK 166771C1

CAV	CIR	GAUGE	COLOR	TERMINAL
A	A86F(+)	18	YL	1661875C1
B	-	-	-	-
C	A86F(-)	18	GN	1661875C1

CHK	DATE	CHANGE	REV	REFERENCE	DRAWN	NAME
DLV1	19NOV09	INITIAL RELEASE.	A	63656A	U00SLK3	CIRCUIT DIAGRAM, PROSTAR, LONESTAR
					RELEASE NO. 63656A	DATE 19OCT09
						PART NO. AE08055906
						SHEET 59A

Figure 300 Connector Composites (2224), (2225), (2227)

14.72. CONNECTOR COMPOSITES (2300), (2301), (2302), P. 60

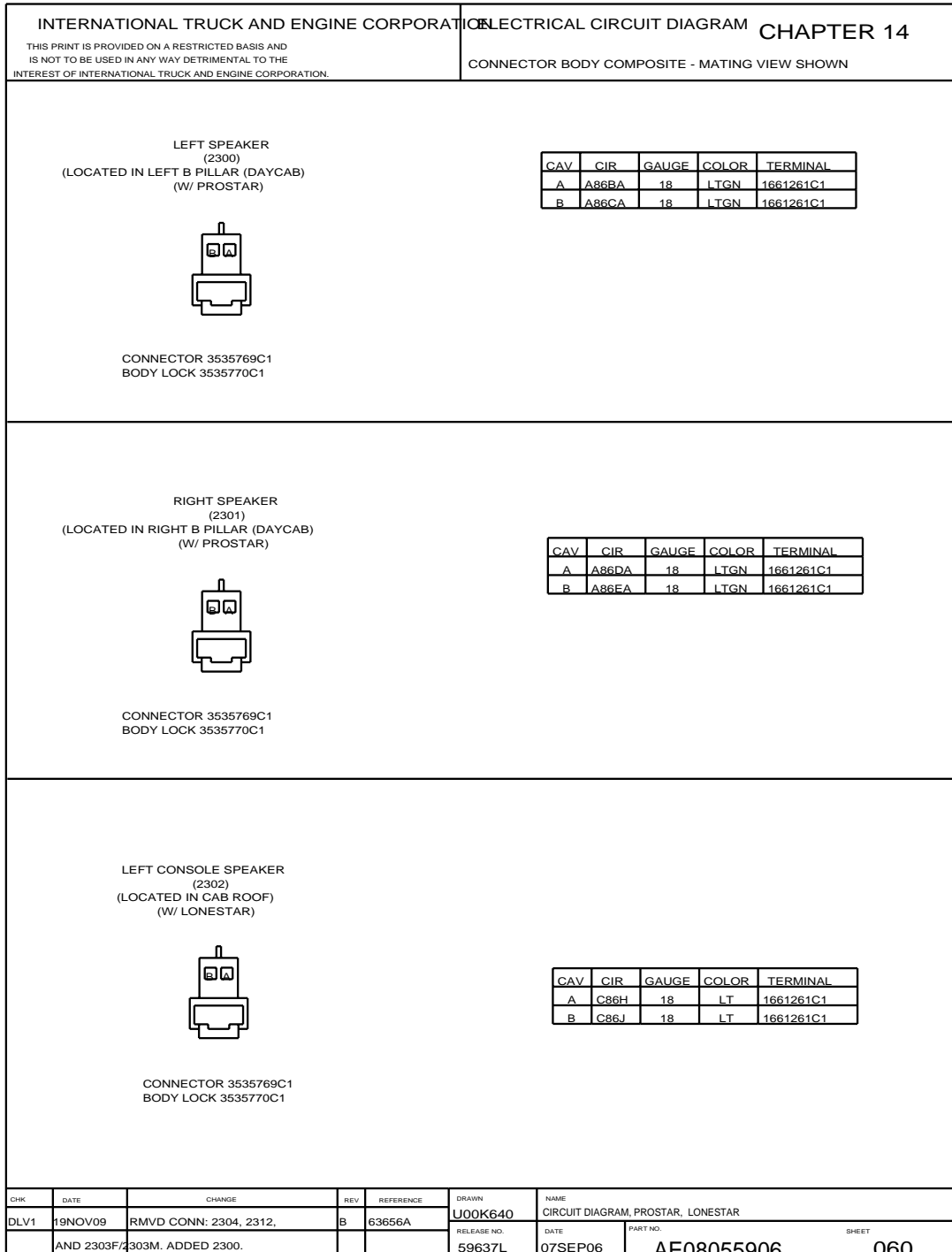


Figure 301 Connector Composites (2300), (2301), (2302)

14.73. CONNECTOR COMPOSITES (2303F/2303M), (2304), (2312), P. 60A

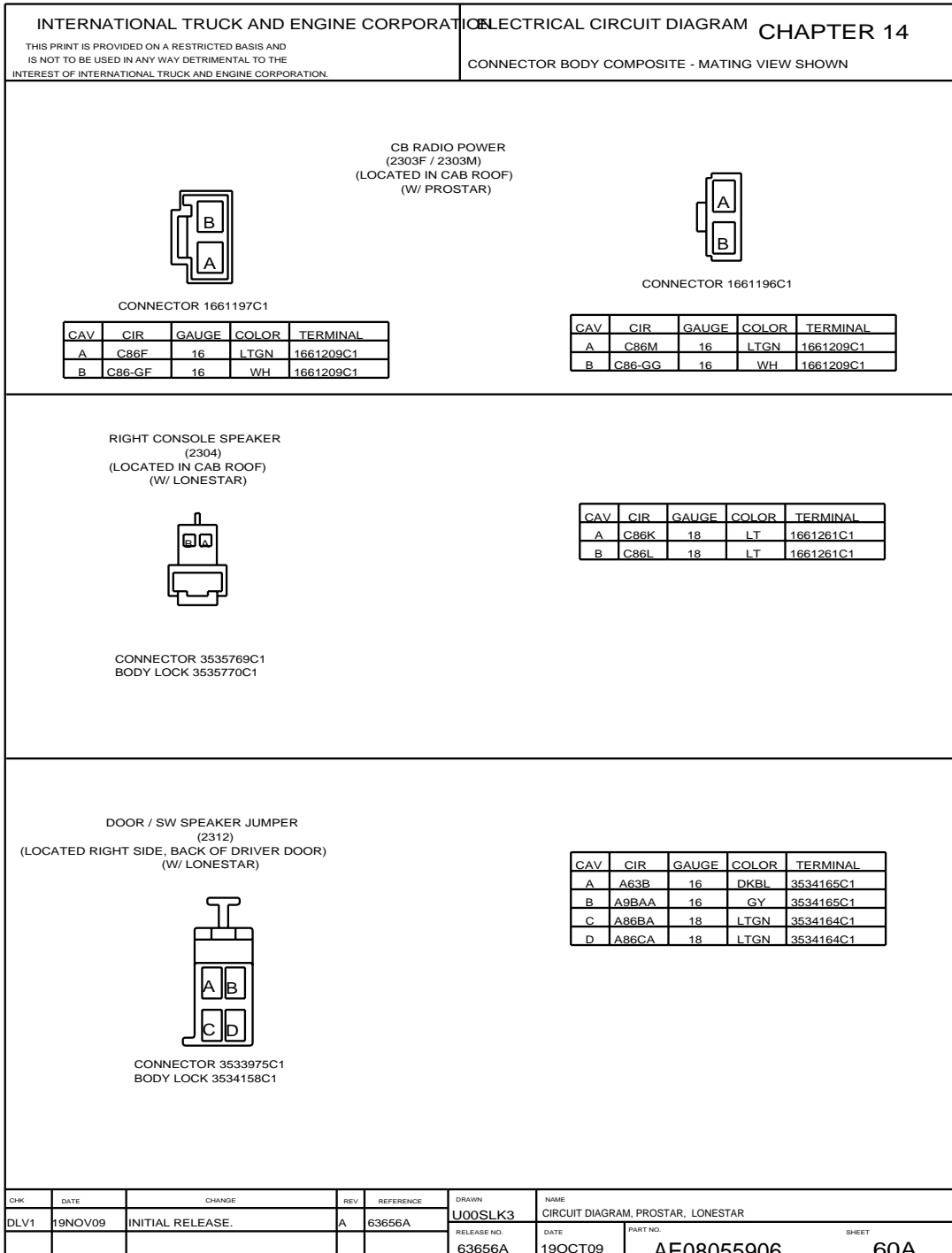


Figure 302 Connector Composites (2303F/2303M), (2304), (2312)

14.74. CONNECTOR COMPOSITES (2313), (2500), P. 61

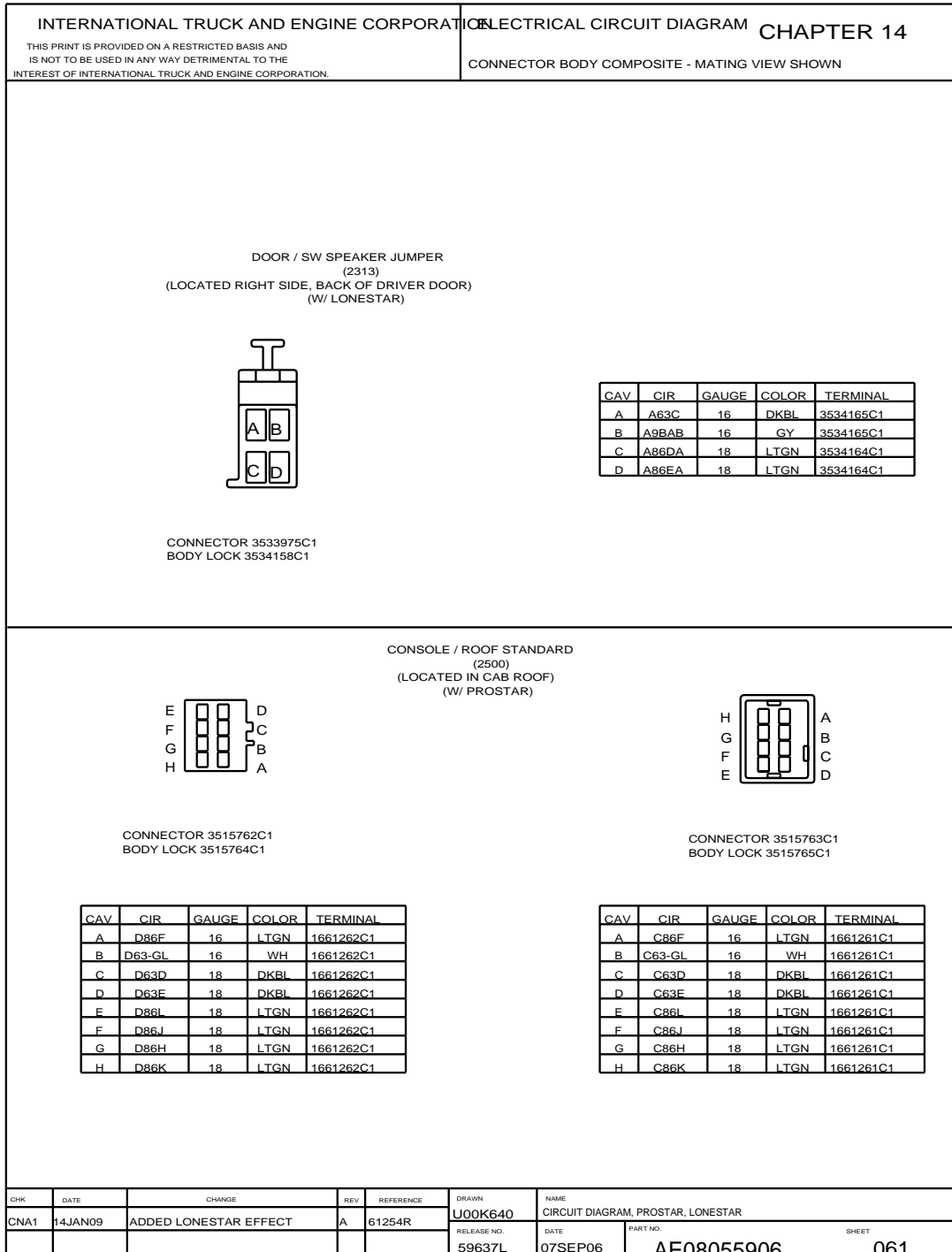


Figure 303 Connector Composites (2313), (2500)

14.75. CONNECTOR COMPOSITES (3000), (3003/3003M), (3100/3100M), P. 62

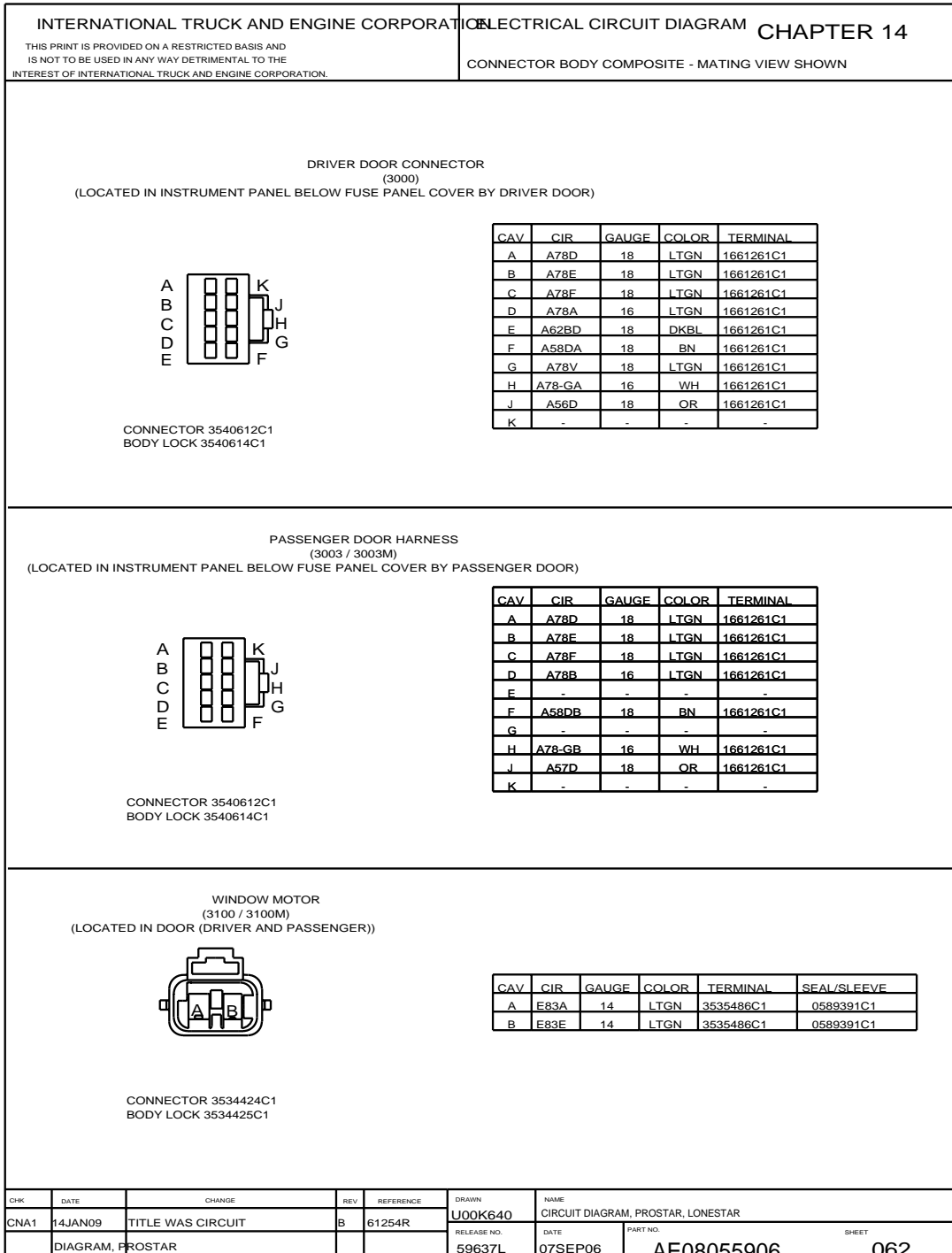
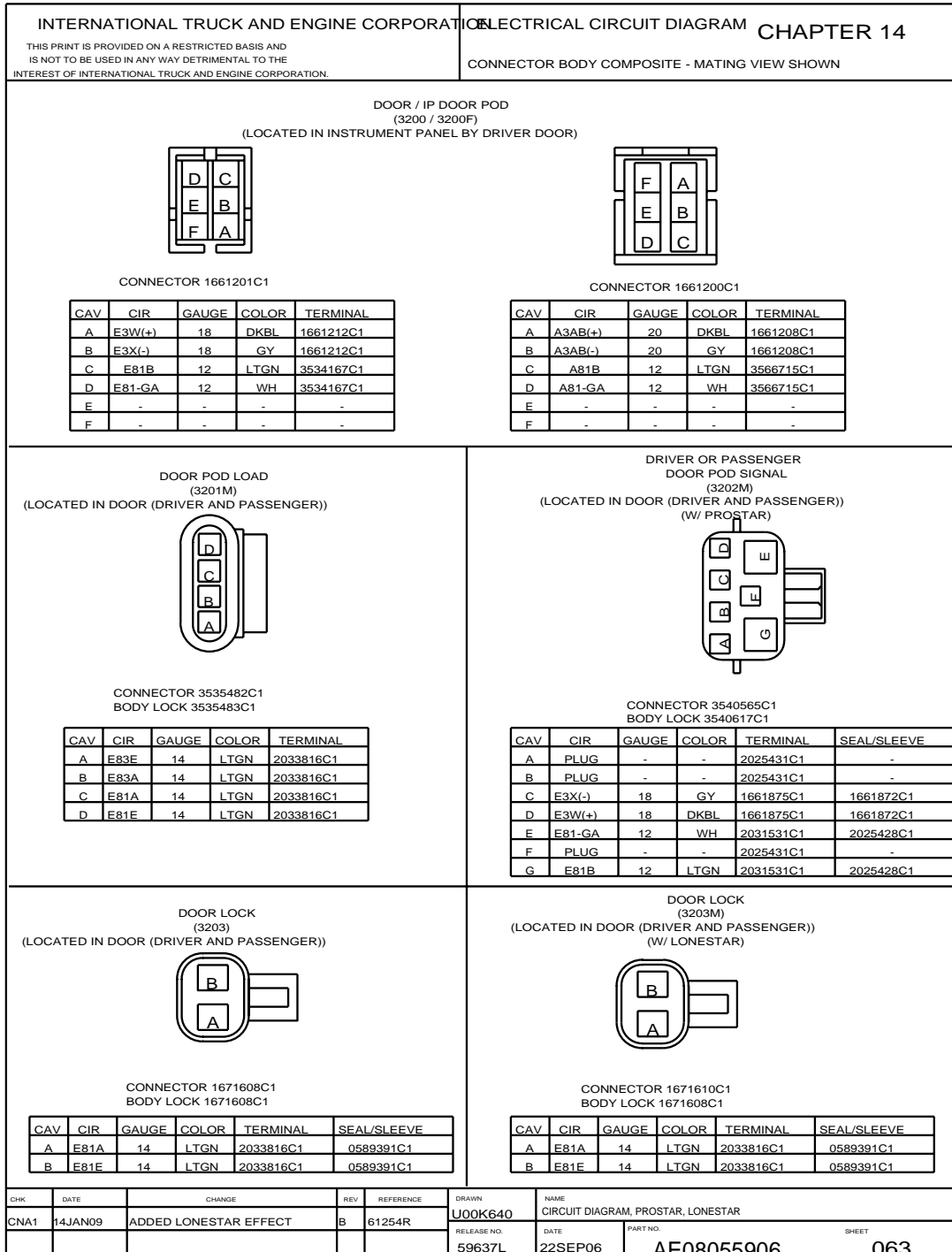


Figure 304 Connector Composites (3000), (3003/3003M), (3100/3100M)

**14.76. CONNECTOR COMPOSITES (3200/3200F), (3201M), (3202M), (3203), (3203M), P. 63**



**Figure 305 Connector Composites (3200/3200F), (3201M), (3202M), (3203), (3203M)**

14.77. CONNECTOR COMPOSITES (3204/3204M), (3205M/3205F), (3206M), (3300/3300M), (3400), (3410), P. 64

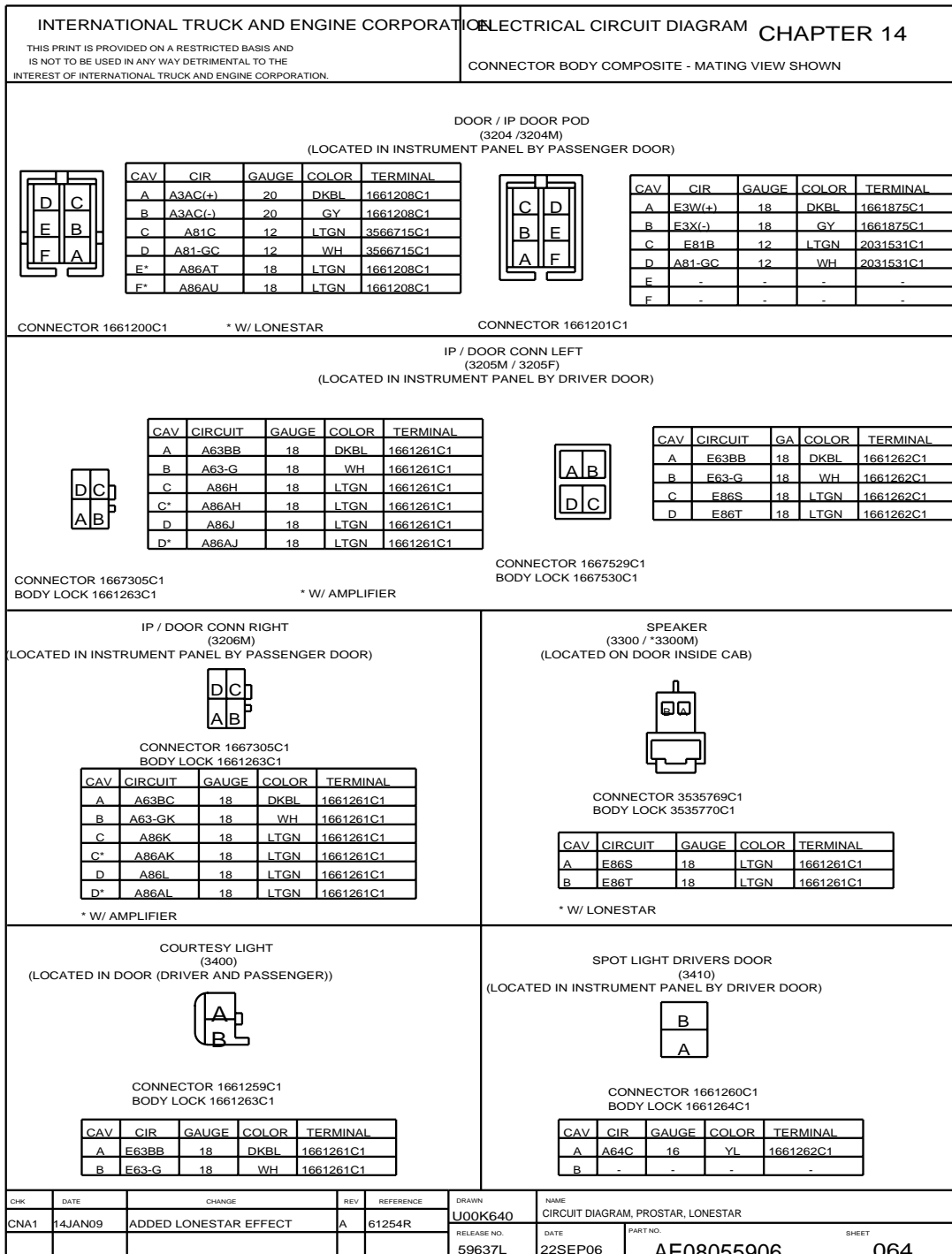


Figure 306 Connector Composites (3204/3204M), (3205M/3205F), (3206M), (3300/3300M), (3400), (3410)

14.78. CONNECTOR COMPOSITES (4101), (4200), (4201), (4202), (4203), (4204), P. 65

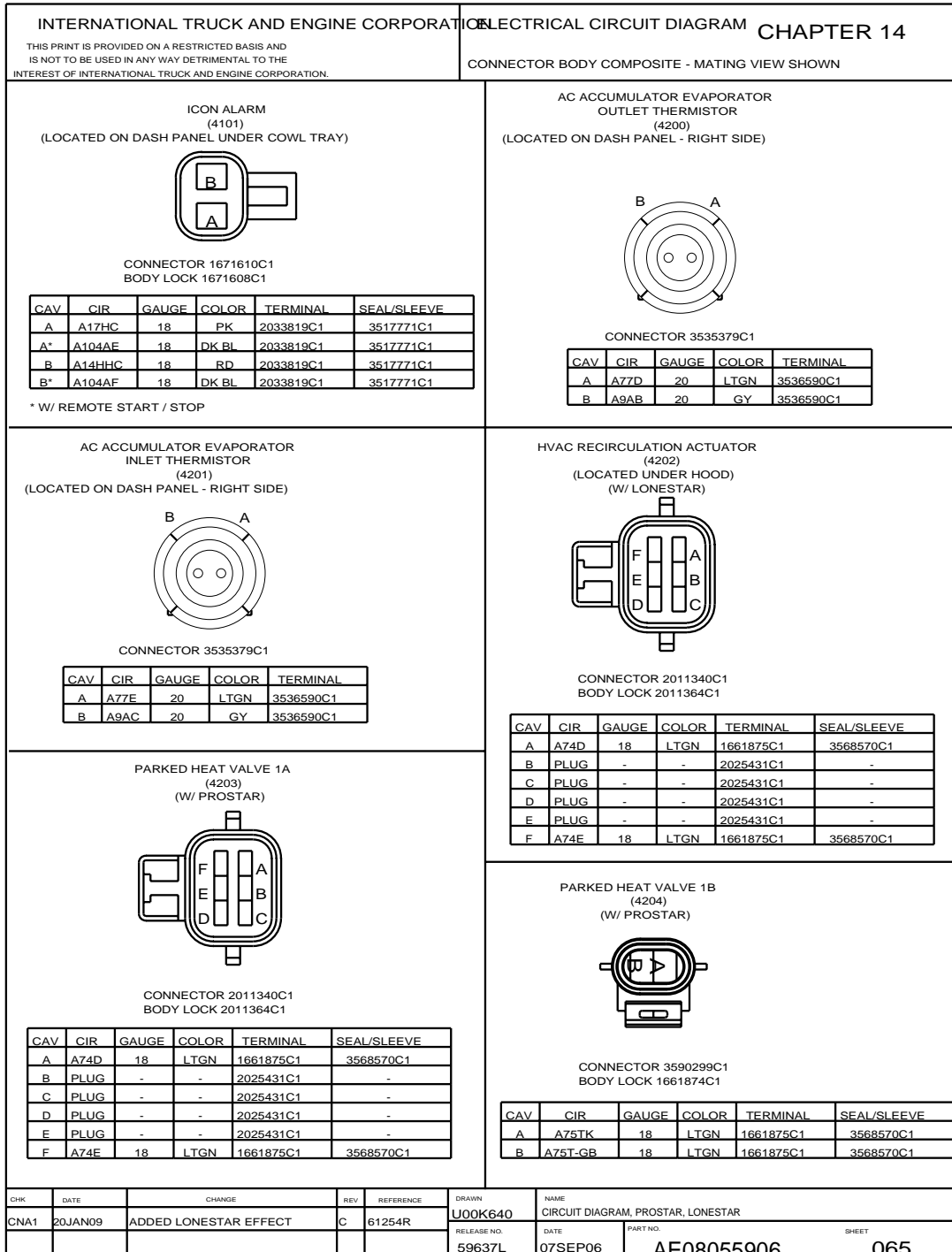


Figure 307 Connector Composites (4101), (4200), (4201), (4202), (4203), (4204)

14.79. CONNECTOR COMPOSITES (4328), (4500), (4705), (4706), P. 65A


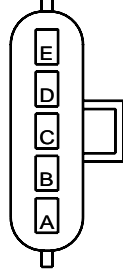
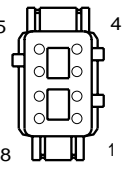
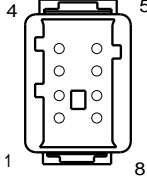
INTERNATIONAL TRUCK AND ENGINE CORPORATION		ELECTRICAL CIRCUIT DIAGRAM		CHAPTER 14																																																																																											
THIS PRINT IS PROVIDED ON A RESTRICTED BASIS AND IS NOT TO BE USED IN ANY WAY DETRIMENTAL TO THE INTEREST OF INTERNATIONAL TRUCK AND ENGINE CORPORATION.		CONNECTOR BODY COMPOSITE - MATING VIEW SHOWN																																																																																													
<p>ENGINE DIAGNOSTICS CONNECTOR (4328) (W/ PROSTAR)</p>  <p>CONNECTOR 3602454C1 BODY LOCK 1655705C1</p> <table border="1" style="width:100%; border-collapse: collapse; font-size: x-small;"> <thead> <tr> <th>CAV</th> <th>CIRCUIT</th> <th>GAUGE</th> <th>COLOR</th> <th>TERMINAL</th> </tr> </thead> <tbody> <tr> <td>A</td> <td>K98YL6</td> <td>18</td> <td>YL</td> <td>3572626C1</td> </tr> <tr> <td>B</td> <td>K98GN6</td> <td>18</td> <td>GN</td> <td>3572626C1</td> </tr> <tr> <td>C</td> <td>K91A</td> <td>18</td> <td>VT</td> <td>3572626C1</td> </tr> </tbody> </table>			CAV	CIRCUIT	GAUGE	COLOR	TERMINAL	A	K98YL6	18	YL	3572626C1	B	K98GN6	18	GN	3572626C1	C	K91A	18	VT	3572626C1	<p>WIPER MOTOR (4500) (LOCATED UNDER HOOD)</p>  <p>CONNECTOR 1661375C2 BODY LOCK 1661376C1</p> <table border="1" style="width:100%; border-collapse: collapse; font-size: x-small;"> <thead> <tr> <th>CAV</th> <th>CIR</th> <th>GAUGE</th> <th>COLOR</th> <th>TERMINAL</th> <th>SEAL/SLEEVE</th> </tr> </thead> <tbody> <tr> <td>A</td> <td>A82D</td> <td>16</td> <td>GY</td> <td>2033819C1</td> <td>1652325C1</td> </tr> <tr> <td>B</td> <td>A82J</td> <td>16</td> <td>GY</td> <td>2033819C1</td> <td>1652325C1</td> </tr> <tr> <td>C</td> <td>A82-G</td> <td>16</td> <td>WH</td> <td>2033819C1</td> <td>1652325C1</td> </tr> <tr> <td>D</td> <td>A82K</td> <td>16</td> <td>GY</td> <td>2033819C1</td> <td>1652325C1</td> </tr> <tr> <td>E</td> <td>A82L</td> <td>16</td> <td>GY</td> <td>2033819C1</td> <td>1652325C1</td> </tr> </tbody> </table>			CAV	CIR	GAUGE	COLOR	TERMINAL	SEAL/SLEEVE	A	A82D	16	GY	2033819C1	1652325C1	B	A82J	16	GY	2033819C1	1652325C1	C	A82-G	16	WH	2033819C1	1652325C1	D	A82K	16	GY	2033819C1	1652325C1	E	A82L	16	GY	2033819C1	1652325C1																																		
CAV	CIRCUIT	GAUGE	COLOR	TERMINAL																																																																																											
A	K98YL6	18	YL	3572626C1																																																																																											
B	K98GN6	18	GN	3572626C1																																																																																											
C	K91A	18	VT	3572626C1																																																																																											
CAV	CIR	GAUGE	COLOR	TERMINAL	SEAL/SLEEVE																																																																																										
A	A82D	16	GY	2033819C1	1652325C1																																																																																										
B	A82J	16	GY	2033819C1	1652325C1																																																																																										
C	A82-G	16	WH	2033819C1	1652325C1																																																																																										
D	A82K	16	GY	2033819C1	1652325C1																																																																																										
E	A82L	16	GY	2033819C1	1652325C1																																																																																										
<p>BODY BUILDER CONNECTOR (4705) (W/ PROSTAR)</p>  <p>CONNECTOR 3539139C1 BODY LOCK 3539144C1</p> <table border="1" style="width:100%; border-collapse: collapse; font-size: x-small;"> <thead> <tr> <th>CAV</th> <th>CIRCUIT</th> <th>GAUGE</th> <th>COLOR</th> <th>TERMINAL</th> </tr> </thead> <tbody> <tr> <td>1</td> <td>K92A15</td> <td>18</td> <td>TN</td> <td>3518963C1</td> </tr> <tr> <td>2</td> <td>K92A11</td> <td>18</td> <td>TN</td> <td>3518963C1</td> </tr> <tr> <td>3</td> <td>K92A12</td> <td>18</td> <td>TN</td> <td>3518963C1</td> </tr> <tr> <td>4</td> <td>K92A13</td> <td>18</td> <td>TN</td> <td>3518963C1</td> </tr> <tr> <td>5</td> <td>K92A9</td> <td>18</td> <td>TN</td> <td>3518963C1</td> </tr> <tr> <td>6</td> <td>K92A10</td> <td>18</td> <td>TN</td> <td>3518963C1</td> </tr> <tr> <td>7</td> <td>K92A8</td> <td>18</td> <td>TN</td> <td>3518963C1</td> </tr> <tr> <td>8</td> <td>PLUG</td> <td>-</td> <td>-</td> <td>3527276C1</td> </tr> </tbody> </table>			CAV	CIRCUIT	GAUGE	COLOR	TERMINAL	1	K92A15	18	TN	3518963C1	2	K92A11	18	TN	3518963C1	3	K92A12	18	TN	3518963C1	4	K92A13	18	TN	3518963C1	5	K92A9	18	TN	3518963C1	6	K92A10	18	TN	3518963C1	7	K92A8	18	TN	3518963C1	8	PLUG	-	-	3527276C1	<p>BODY BUILDER CONNECTOR 2 (4706) (W/ PROSTAR)</p>  <p>CONNECTOR 3539140C1 BODY LOCK 3539145C1</p> <table border="1" style="width:100%; border-collapse: collapse; font-size: x-small;"> <thead> <tr> <th>CAV</th> <th>CIRCUIT</th> <th>GAUGE</th> <th>COLOR</th> <th>TERMINAL</th> </tr> </thead> <tbody> <tr> <td>1</td> <td>K92A5</td> <td>18</td> <td>TN</td> <td>3518961C1</td> </tr> <tr> <td>2</td> <td>K92A4</td> <td>18</td> <td>TN</td> <td>3518961C1</td> </tr> <tr> <td>3</td> <td>K92A3</td> <td>18</td> <td>TN</td> <td>3518961C1</td> </tr> <tr> <td>4</td> <td>K92A14</td> <td>18</td> <td>TN</td> <td>3518961C1</td> </tr> <tr> <td>5</td> <td>K92A2</td> <td>18</td> <td>TN</td> <td>3518961C1</td> </tr> <tr> <td>6</td> <td>K92A6</td> <td>18</td> <td>TN</td> <td>3518961C1</td> </tr> <tr> <td>7</td> <td>K92A7</td> <td>18</td> <td>TN</td> <td>3518961C1</td> </tr> <tr> <td>8</td> <td>K92A1</td> <td>18</td> <td>TN</td> <td>3518961C1</td> </tr> </tbody> </table>			CAV	CIRCUIT	GAUGE	COLOR	TERMINAL	1	K92A5	18	TN	3518961C1	2	K92A4	18	TN	3518961C1	3	K92A3	18	TN	3518961C1	4	K92A14	18	TN	3518961C1	5	K92A2	18	TN	3518961C1	6	K92A6	18	TN	3518961C1	7	K92A7	18	TN	3518961C1	8	K92A1	18	TN	3518961C1
CAV	CIRCUIT	GAUGE	COLOR	TERMINAL																																																																																											
1	K92A15	18	TN	3518963C1																																																																																											
2	K92A11	18	TN	3518963C1																																																																																											
3	K92A12	18	TN	3518963C1																																																																																											
4	K92A13	18	TN	3518963C1																																																																																											
5	K92A9	18	TN	3518963C1																																																																																											
6	K92A10	18	TN	3518963C1																																																																																											
7	K92A8	18	TN	3518963C1																																																																																											
8	PLUG	-	-	3527276C1																																																																																											
CAV	CIRCUIT	GAUGE	COLOR	TERMINAL																																																																																											
1	K92A5	18	TN	3518961C1																																																																																											
2	K92A4	18	TN	3518961C1																																																																																											
3	K92A3	18	TN	3518961C1																																																																																											
4	K92A14	18	TN	3518961C1																																																																																											
5	K92A2	18	TN	3518961C1																																																																																											
6	K92A6	18	TN	3518961C1																																																																																											
7	K92A7	18	TN	3518961C1																																																																																											
8	K92A1	18	TN	3518961C1																																																																																											
CHK	DATE	CHANGE	REV	REFERENCE	DRAWN	NAME																																																																																									
CNA1	14JAN09	TITLE WAS CIRCUIT	B	61254R	380061	CIRCUIT DIAGRAM, PROSTAR, LONESTAR																																																																																									
		DIAGRAM, PROSTAR			61296K	08APR08																																																																																									
						PART NO. AE08055906																																																																																									
						SHEET 65A																																																																																									

Figure 308 Connector Composites (4328), (4500), (4705), (4706)

14.80. CONNECTOR COMPOSITES (5000/5000A), P. 66

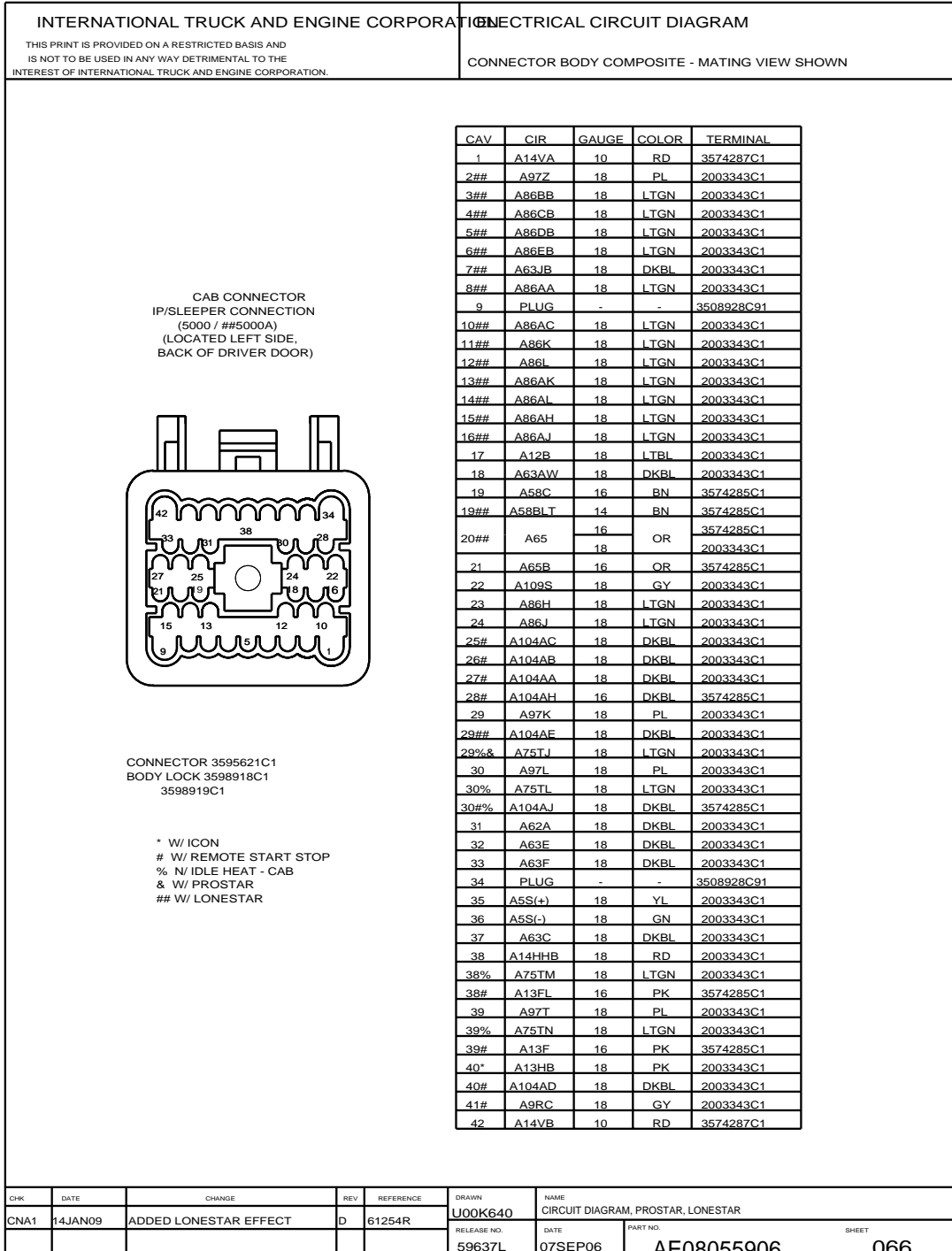


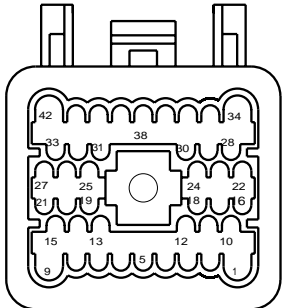
Figure 309 Connector Composites (5000/5000A)

14.81. CONNECTOR COMPOSITES (5000), P. 67

<p>INTERNATIONAL TRUCK AND ENGINE CORPORATION</p> <p>THIS PRINT IS PROVIDED ON A RESTRICTED BASIS AND IS NOT TO BE USED IN ANY WAY DETRIMENTAL TO THE INTEREST OF INTERNATIONAL TRUCK AND ENGINE CORPORATION.</p>	<p>ELECTRICAL CIRCUIT DIAGRAM CHAPTER 14</p> <p>CONNECTOR BODY COMPOSITE - MATING VIEW SHOWN</p>
---	--

CAB / SLEEPER  
SLEEPER CONNECTOR  
(5000)  
(LOCATED LEFT SIDE, BACK OF DRIVER DOOR)



CONNECTOR 3595620C1  
BODY LOCK 3598916C1  
3598917C1

\* W/ IDLE MANAGEMENT  
# N/ ICON  
% N/ IDLE HEAT - CAB  
\*\* W/ REMOTE START / STOP  
& W/ PROSTAR  
## W/ LONESTAR

CAV	CIR	GAUGE	COLOR	TERMINAL
1	H14VA	10	RD	3549415C1
2	H97Z	18	VT	3549418C1
3	H86BB	18	LTGN	3549418C1
4	H86CB	18	LTGN	3549418C1
5	H86DB	18	LTGN	3549418C1
6	H86ED	18	LTGN	3549418C1
7	H63JB	18	DKBL	3549418C1
8	H86AB	18	LTGN	3549418C1
9	PLUG	-	-	3508928C1
10	H86AC	18	LTGN	3549418C1
11	H86K	18	LTGN	3549418C1
12	H86L	18	LTGN	3549418C1
13	H86AK	18	LTGN	3549418C1
14	H86AL	18	LTGN	3549418C1
15	H86AH	18	LTGN	3549418C1
16	H86AJ	18	LTGN	3549418C1
17*	H12B	18	LTBL	3549418C1
17#	H12B	18	VT	3549418C1
18	H63AW	18	DKBL	3549418C1
19	H58C	16	BK	3549418C1
20	H65	16	OR	3549417C1
21	H65B	16	OR	3549418C1
22	H109S	18	GY	3549418C1
23##	H86H	18	LTGN	3549418C1
24##	H86J	18	LTGN	3549418C1
25**	H104AC	18	DKBL	3549418C1
26**	H104AB	18	DKBL	3549418C1
27**	H104AA	18	DKBL	3549418C1
28**	H104AH	18	DKBL	3549418C1
29	H97K	18	VT	3549418C1
29%&	HH75TJ	18	LTGN	3549418C1
29**	H104AE	18	DKBL	3549418C1
30	H97L	18	VT	3549418C1
30%	HH75TL	18	LTGN	3549418C1
30**	H104AJ	18	DKBL	3549418C1
31	H62A	18	DKBL	3549418C1
32	H63E	18	DKBL	3549418C1
33	H63F	18	DKBL	3549418C1
34	PLUG	-	-	3508928C1
35	H5S(+)	18	YL	3549418C1
36	H5S(-)	18	GN	3549418C1
37	H63C	18	DKBL	3549418C1
38	H14HHB	18	RD	3549418C1
38%	H75TM	18	LTGN	3549418C1
38**	H13FL	16	PK	3549418C1
39	H97T	18	VT	3549418C1
39%	H75TN	18	LTGN	3549418C1
39**	H13F	18	DKBL	3549418C1
40	H13HB	18	PK	3549418C1
40**	H104AD	18	DKBL	3549418C1
41**	H9RC	18	GY	3549418C1
42	H14VB	10	RD	3549415C1

CHK	DATE	CHANGE	REV	REFERENCE	DRAWN	NAME
CNA1	14JAN09	ADDED LONESTAR EFFECT	C	61254R	U00K640	CIRCUIT DIAGRAM, PROSTAR, LONESTAR
					RELEASE NO.	DATE
					59637L	07SEP06
						PART NO.
						AE08055906
						SHEET
						067

Figure 310 Connector Composites (5000)

14.82. CONNECTOR COMPOSITES (5001), P. 68

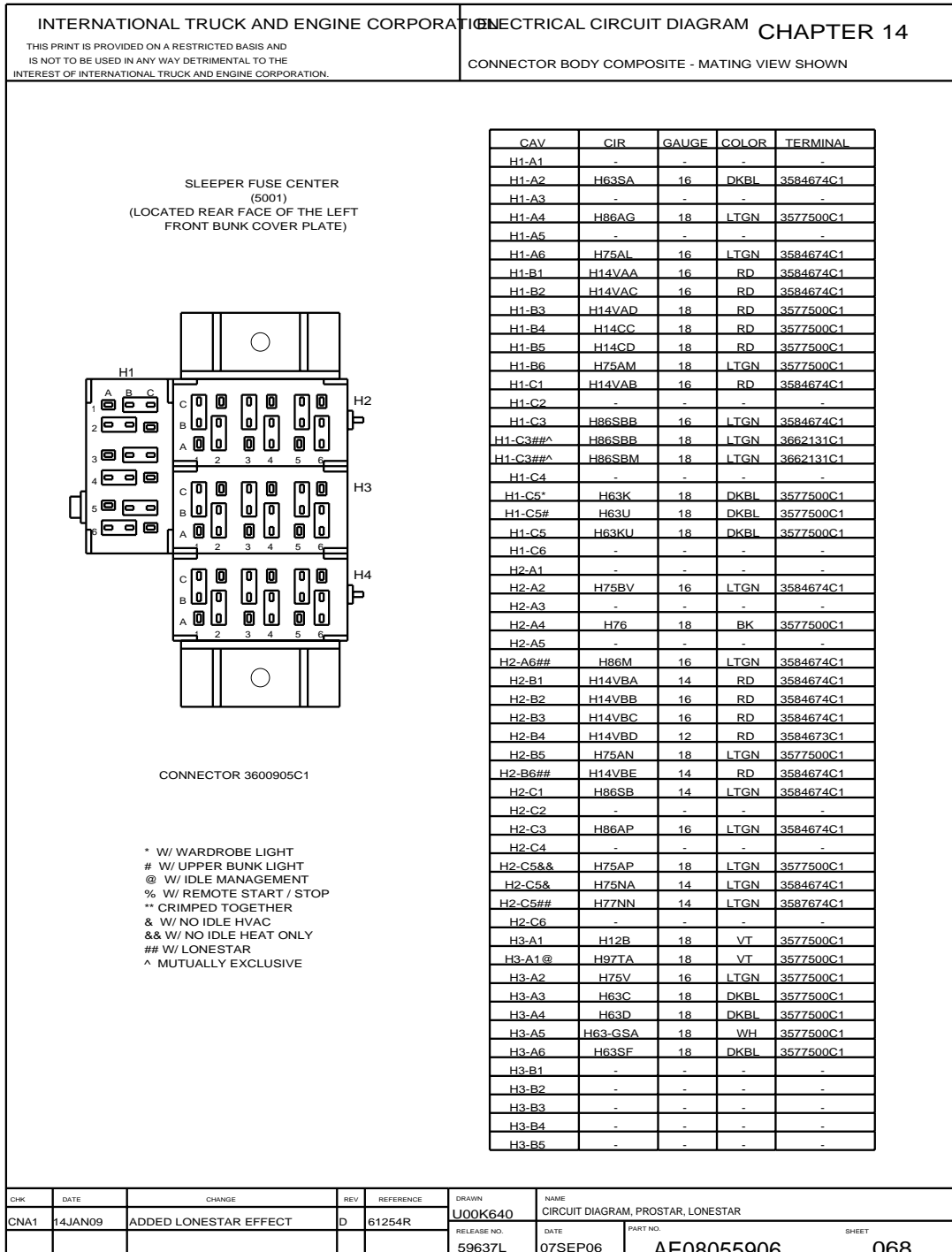


Figure 311 Connector Composites (5001)

14.83. CONNECTOR COMPOSITES (5001), P. 68A

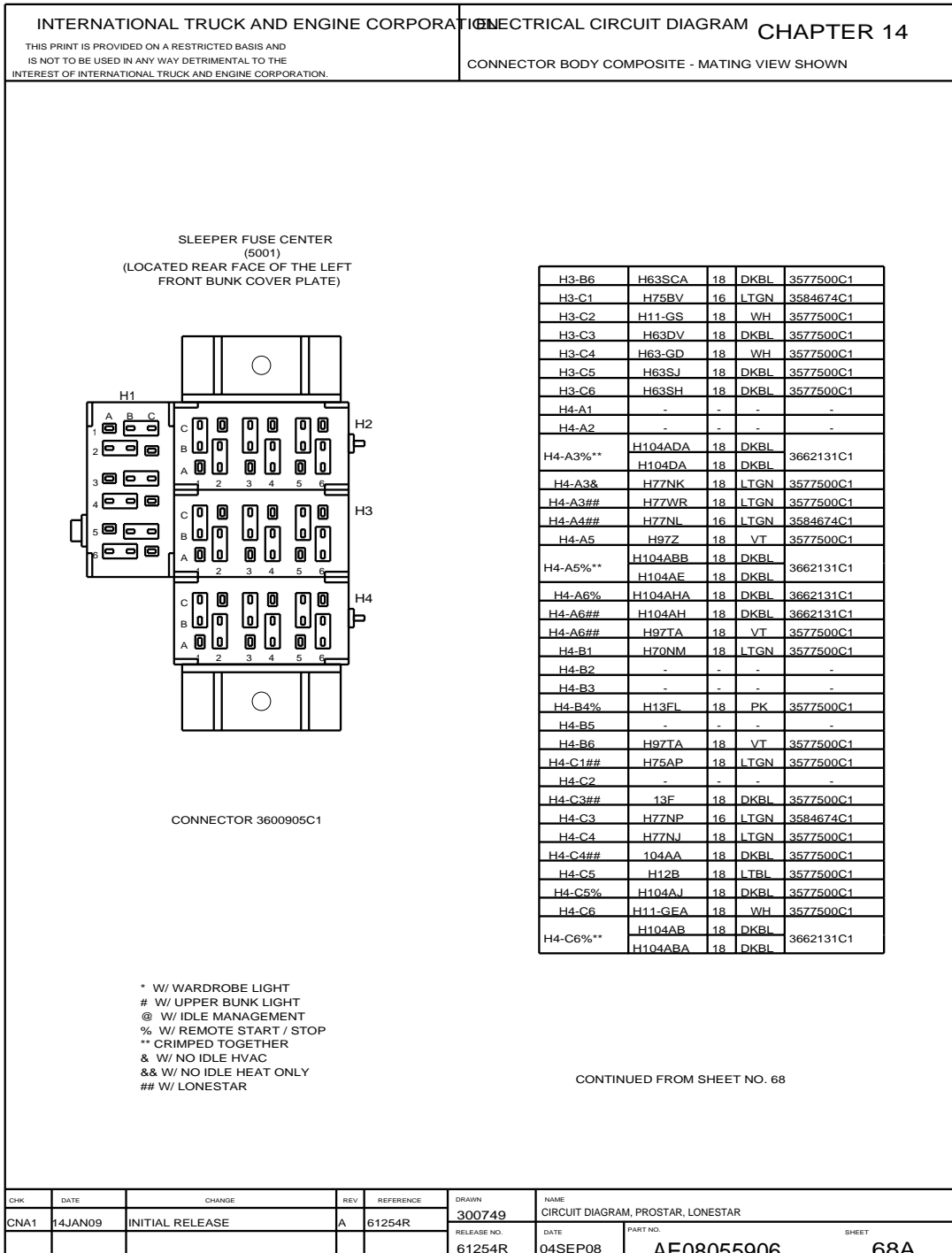


Figure 312 Connector Composites (5001)

14.84. CONNECTOR COMPOSITES (5003), (5005), (5006), (5007), P. 69




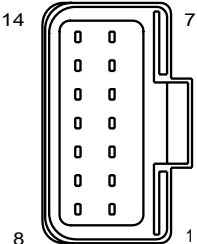
INTERNATIONAL TRUCK AND ENGINE CORPORATION		ELECTRICAL CIRCUIT DIAGRAM		CHAPTER 14																																																																																																																																																																	
THIS PRINT IS PROVIDED ON A RESTRICTED BASIS AND IS NOT TO BE USED IN ANY WAY DETRIMENTAL TO THE INTEREST OF INTERNATIONAL TRUCK AND ENGINE CORPORATION.		CONNECTOR BODY COMPOSITE - MATING VIEW SHOWN																																																																																																																																																																			
12V POWER SOURCE (5003) (LOCATED IN SLEEPER CONTROL PANEL)		CONNECTOR 3613000C1 BODY LOCK 3557682C1																																																																																																																																																																			
		<table border="1" style="width:100%; border-collapse: collapse;"> <thead> <tr> <th>CAV</th> <th>CIR</th> <th>GAUGE</th> <th>COLOR</th> <th>TERMINAL</th> </tr> </thead> <tbody> <tr> <td>A</td> <td>H86SBA</td> <td>16</td> <td>LTBL</td> <td>3534165C1</td> </tr> <tr> <td>B</td> <td>-</td> <td>-</td> <td>-</td> <td>-</td> </tr> <tr> <td>C</td> <td>H86-GSA</td> <td>16</td> <td>WH</td> <td>3534165C1</td> </tr> </tbody> </table>				CAV	CIR	GAUGE	COLOR	TERMINAL	A	H86SBA	16	LTBL	3534165C1	B	-	-	-	-	C	H86-GSA	16	WH	3534165C1																																																																																																																																												
CAV	CIR	GAUGE	COLOR	TERMINAL																																																																																																																																																																	
A	H86SBA	16	LTBL	3534165C1																																																																																																																																																																	
B	-	-	-	-																																																																																																																																																																	
C	H86-GSA	16	WH	3534165C1																																																																																																																																																																	
12V POWER SOURCE (5005) (LOCATED UNDER BUNK - RIGHT SIDE)		CONNECTOR 0872291R1																																																																																																																																																																			
		<table border="1" style="width:100%; border-collapse: collapse;"> <thead> <tr> <th>CAV</th> <th>CIR</th> <th>GAUGE</th> <th>COLOR</th> <th>TERMINAL</th> </tr> </thead> <tbody> <tr> <td>A</td> <td>H86-GSC</td> <td>16</td> <td>WH</td> <td>0188396R1</td> </tr> <tr> <td>B</td> <td>H86SA</td> <td>16</td> <td>LTGN</td> <td>0188396R1</td> </tr> </tbody> </table>				CAV	CIR	GAUGE	COLOR	TERMINAL	A	H86-GSC	16	WH	0188396R1	B	H86SA	16	LTGN	0188396R1																																																																																																																																																	
CAV	CIR	GAUGE	COLOR	TERMINAL																																																																																																																																																																	
A	H86-GSC	16	WH	0188396R1																																																																																																																																																																	
B	H86SA	16	LTGN	0188396R1																																																																																																																																																																	
POWER PANEL GROUND (5006) (LOCATED UNDER BUNK)		CONNECTOR 1661197C1																																																																																																																																																																			
		<table border="1" style="width:100%; border-collapse: collapse;"> <thead> <tr> <th>CAV</th> <th>CIR</th> <th>GAUGE</th> <th>COLOR</th> <th>TERMINAL</th> </tr> </thead> <tbody> <tr> <td>A</td> <td>-</td> <td>-</td> <td>-</td> <td>-</td> </tr> <tr> <td>B</td> <td>HA11-GSP</td> <td>14</td> <td>WH</td> <td>3534167C1</td> </tr> </tbody> </table>				CAV	CIR	GAUGE	COLOR	TERMINAL	A	-	-	-	-	B	HA11-GSP	14	WH	3534167C1																																																																																																																																																	
CAV	CIR	GAUGE	COLOR	TERMINAL																																																																																																																																																																	
A	-	-	-	-																																																																																																																																																																	
B	HA11-GSP	14	WH	3534167C1																																																																																																																																																																	
GROUND ADAPTER (5007) (LOCATED REAR FACE OF FRONT LEFT BUNK PANEL)		CONNECTOR 3613769C1																																																																																																																																																																			
		<table border="1" style="width:100%; border-collapse: collapse;"> <thead> <tr> <th>CAV</th> <th>CIR</th> <th>GAUGE</th> <th>COLOR</th> <th>TERMINAL</th> </tr> </thead> <tbody> <tr><td>1</td><td>H11-GM</td><td>10</td><td>WH</td><td>3613770C1</td></tr> <tr><td>1^</td><td>H11-GM</td><td>10</td><td>WH</td><td>3612307C1</td></tr> <tr><td>2</td><td>H58-G</td><td>16</td><td>WH</td><td>3613771C1</td></tr> <tr><td>2^</td><td>H58-G</td><td>16</td><td>WH</td><td>3613770C1</td></tr> <tr><td>3</td><td>H86-GH</td><td>16</td><td>LTGN</td><td>3613770C1</td></tr> <tr><td>3^</td><td>H86-GH</td><td>16</td><td>LTGN</td><td>3613770C1</td></tr> <tr><td>4</td><td>H65-GE</td><td>16</td><td>WH</td><td>3613771C1</td></tr> <tr><td>4^</td><td>H65-GE</td><td>16</td><td>WH</td><td>3613770C1</td></tr> <tr><td>5</td><td>H86-GHW</td><td>18</td><td>LTGN</td><td>3613771C1</td></tr> <tr><td>6</td><td>H86-GK</td><td>18</td><td>WH</td><td>3613771C1</td></tr> <tr><td>7</td><td>H11-GSP</td><td>14</td><td>WH</td><td>3613770C1</td></tr> <tr><td>8</td><td>H63-GK</td><td>18</td><td>WH</td><td>3613771C1</td></tr> <tr><td>8&amp;</td><td>H63-GU</td><td>18</td><td>WH</td><td>3613771C1</td></tr> <tr><td>8&amp;</td><td>H63-GX</td><td>18</td><td>WH</td><td>3613771C1</td></tr> <tr><td>9</td><td>H75-GB</td><td>18</td><td>WH</td><td>3613771C1</td></tr> <tr><td>9#</td><td>H75-GB</td><td>18</td><td>LTGN</td><td>3613771C1</td></tr> <tr><td>9%</td><td>H77NT</td><td>14</td><td>LTGN</td><td>3613770C1</td></tr> <tr><td>10</td><td>H11-GT</td><td>14</td><td>WH</td><td>3613770C1</td></tr> <tr><td>10^</td><td>H63-GU</td><td>18</td><td>WH</td><td>3613771C1</td></tr> <tr><td>11*</td><td>H11-GSD</td><td>18</td><td>WH</td><td>3613771C1</td></tr> <tr><td>11+</td><td>H11-GMB</td><td>18</td><td>WH</td><td>3613771C1</td></tr> <tr><td>11++</td><td>H11-GMC</td><td>18</td><td>WH</td><td>3613771C1</td></tr> <tr><td>11@</td><td>H11-GMB</td><td>18</td><td>WH</td><td>3613771C1</td></tr> <tr><td>11**</td><td>H11-GMD</td><td>18</td><td>WH</td><td>3613771C1</td></tr> <tr><td>12</td><td>H76-G</td><td>18</td><td>WH</td><td>3613771C1</td></tr> <tr><td>12^</td><td>H86-GSB</td><td>16</td><td>WH</td><td>3613770C1</td></tr> <tr><td>13</td><td>H75-GSX</td><td>14</td><td>WH</td><td>3613770C1</td></tr> <tr><td>13##</td><td>H104-GB</td><td>18</td><td>DKBL</td><td>3613771C1</td></tr> <tr><td>13@@</td><td>H11-GEC</td><td>18</td><td>WH</td><td>3613771C1</td></tr> <tr><td>14</td><td>H86-GSB</td><td>16</td><td>WH</td><td>3613770C1</td></tr> <tr><td>14^</td><td>H86-GSM</td><td>16</td><td>WH</td><td>3613770C1</td></tr> </tbody> </table>				CAV	CIR	GAUGE	COLOR	TERMINAL	1	H11-GM	10	WH	3613770C1	1^	H11-GM	10	WH	3612307C1	2	H58-G	16	WH	3613771C1	2^	H58-G	16	WH	3613770C1	3	H86-GH	16	LTGN	3613770C1	3^	H86-GH	16	LTGN	3613770C1	4	H65-GE	16	WH	3613771C1	4^	H65-GE	16	WH	3613770C1	5	H86-GHW	18	LTGN	3613771C1	6	H86-GK	18	WH	3613771C1	7	H11-GSP	14	WH	3613770C1	8	H63-GK	18	WH	3613771C1	8&	H63-GU	18	WH	3613771C1	8&	H63-GX	18	WH	3613771C1	9	H75-GB	18	WH	3613771C1	9#	H75-GB	18	LTGN	3613771C1	9%	H77NT	14	LTGN	3613770C1	10	H11-GT	14	WH	3613770C1	10^	H63-GU	18	WH	3613771C1	11*	H11-GSD	18	WH	3613771C1	11+	H11-GMB	18	WH	3613771C1	11++	H11-GMC	18	WH	3613771C1	11@	H11-GMB	18	WH	3613771C1	11**	H11-GMD	18	WH	3613771C1	12	H76-G	18	WH	3613771C1	12^	H86-GSB	16	WH	3613770C1	13	H75-GSX	14	WH	3613770C1	13##	H104-GB	18	DKBL	3613771C1	13@@	H11-GEC	18	WH	3613771C1	14	H86-GSB	16	WH	3613770C1	14^	H86-GSM	16	WH	3613770C1
CAV	CIR	GAUGE	COLOR	TERMINAL																																																																																																																																																																	
1	H11-GM	10	WH	3613770C1																																																																																																																																																																	
1^	H11-GM	10	WH	3612307C1																																																																																																																																																																	
2	H58-G	16	WH	3613771C1																																																																																																																																																																	
2^	H58-G	16	WH	3613770C1																																																																																																																																																																	
3	H86-GH	16	LTGN	3613770C1																																																																																																																																																																	
3^	H86-GH	16	LTGN	3613770C1																																																																																																																																																																	
4	H65-GE	16	WH	3613771C1																																																																																																																																																																	
4^	H65-GE	16	WH	3613770C1																																																																																																																																																																	
5	H86-GHW	18	LTGN	3613771C1																																																																																																																																																																	
6	H86-GK	18	WH	3613771C1																																																																																																																																																																	
7	H11-GSP	14	WH	3613770C1																																																																																																																																																																	
8	H63-GK	18	WH	3613771C1																																																																																																																																																																	
8&	H63-GU	18	WH	3613771C1																																																																																																																																																																	
8&	H63-GX	18	WH	3613771C1																																																																																																																																																																	
9	H75-GB	18	WH	3613771C1																																																																																																																																																																	
9#	H75-GB	18	LTGN	3613771C1																																																																																																																																																																	
9%	H77NT	14	LTGN	3613770C1																																																																																																																																																																	
10	H11-GT	14	WH	3613770C1																																																																																																																																																																	
10^	H63-GU	18	WH	3613771C1																																																																																																																																																																	
11*	H11-GSD	18	WH	3613771C1																																																																																																																																																																	
11+	H11-GMB	18	WH	3613771C1																																																																																																																																																																	
11++	H11-GMC	18	WH	3613771C1																																																																																																																																																																	
11@	H11-GMB	18	WH	3613771C1																																																																																																																																																																	
11**	H11-GMD	18	WH	3613771C1																																																																																																																																																																	
12	H76-G	18	WH	3613771C1																																																																																																																																																																	
12^	H86-GSB	16	WH	3613770C1																																																																																																																																																																	
13	H75-GSX	14	WH	3613770C1																																																																																																																																																																	
13##	H104-GB	18	DKBL	3613771C1																																																																																																																																																																	
13@@	H11-GEC	18	WH	3613771C1																																																																																																																																																																	
14	H86-GSB	16	WH	3613770C1																																																																																																																																																																	
14^	H86-GSM	16	WH	3613770C1																																																																																																																																																																	
* W/ TRIP MASTER + W/ QUALCOMM W/ TMCT ++ W/ QUALCOMM W/ IMCT @ W/ SATELLITE COMMUNICATION ** W/ XATA # W/ COOLANT HEATER ## W/ REMOTE START / STOP & W/ WARDROBE & UPPER BUNK LIGHTS-W/72" CAB && W/ UPPER BUNK LIGHT-W/72" CAB @@ W/ IDLE MANAGEMENT-W/51" CAB % W/ NO IDLE HVAC ^ W/ LONESTAR																																																																																																																																																																					
CHK	DATE	CHANGE	REV	REFERENCE	DRAWN																																																																																																																																																																
CNA1	14JAN09	ADDED LONESTAR EFFECT	D	61254R	U00K640																																																																																																																																																																
					CIRCUIT DIAGRAM, PROSTAR, LONESTAR																																																																																																																																																																
				RELEASE NO.	DATE																																																																																																																																																																
				59637L	07SEP06																																																																																																																																																																
				PART NO.	SHEET																																																																																																																																																																
				AE08055906	069																																																																																																																																																																

Figure 313 Connector Composites (5003), (5005), (5006), (5007)

14.85. CONNECTOR COMPOSITES (5007), P. 69A

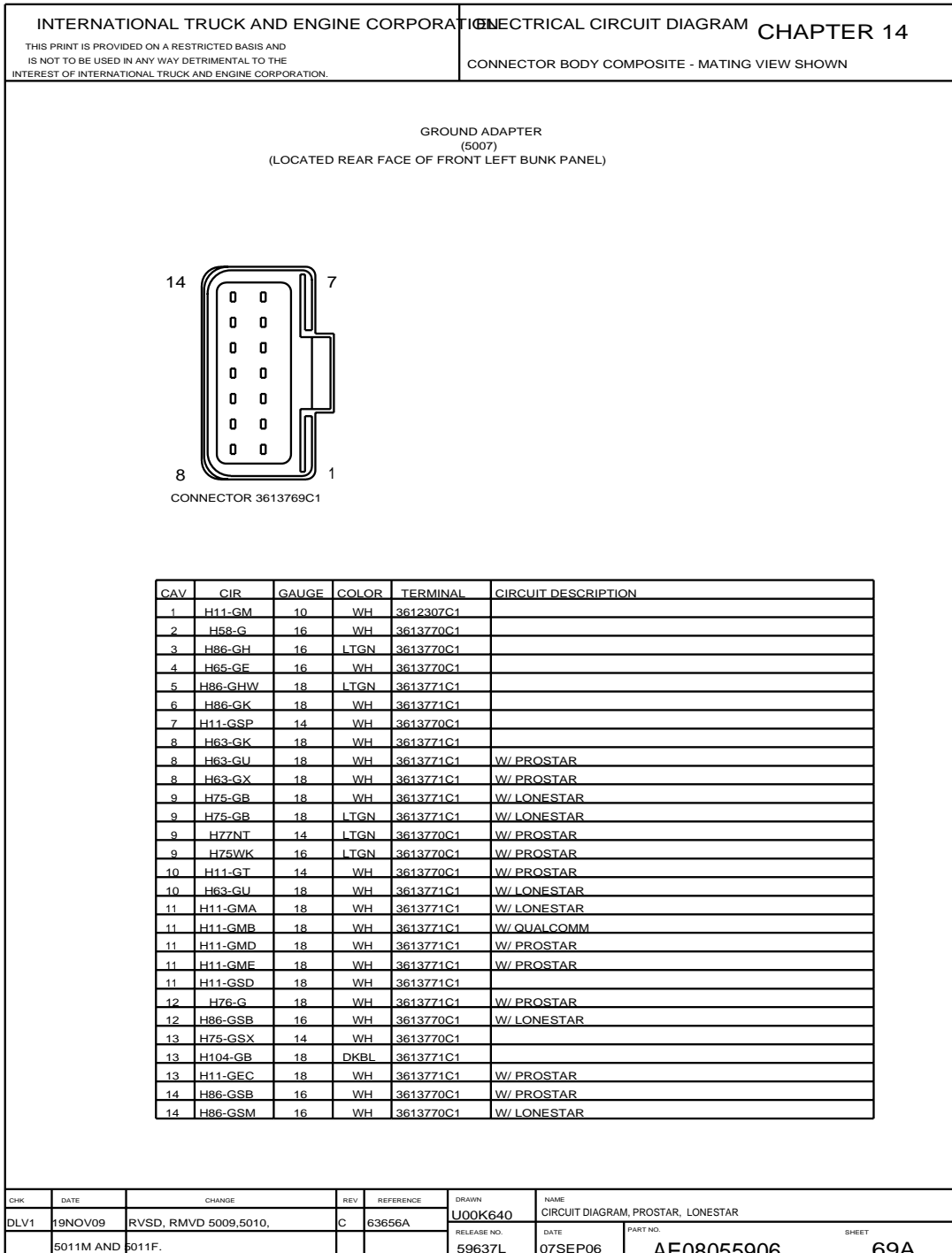


Figure 314 Connector Composites (5007)

14.86. CONNECTOR COMPOSITES (5009), (5010), (5011M/5011F), P. 69B

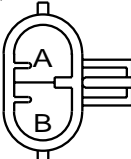
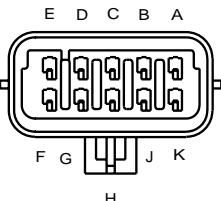
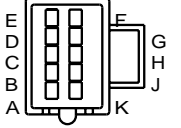
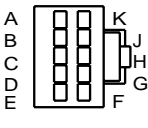
<p>INTERNATIONAL TRUCK AND ENGINE CORPORATION THIS PRINT IS PROVIDED ON A RESTRICTED BASIS AND IS NOT TO BE USED IN ANY WAY DETRIMENTAL TO THE INTEREST OF INTERNATIONAL TRUCK AND ENGINE CORPORATION.</p>	<p>ELECTRICAL CIRCUIT DIAGRAM CHAPTER 14 CONNECTOR BODY COMPOSITE - MATING VIEW SHOWN</p>																																																																																																																								
<p>AUX HEATER (5009) (LOCATED ON RIGHT SIDE, BACK OF PASSENGER DOOR)</p>  <p>CONNECTOR 2031520C1 BODY LOCK 2033927C1</p>	<table border="1" style="width:100%; border-collapse: collapse;"> <thead> <tr> <th>CAV</th> <th>CIR</th> <th>GAUGE</th> <th>COLOR</th> <th>TERMINAL</th> <th>SEAL/SLEEVE</th> </tr> </thead> <tbody> <tr> <td>A</td> <td>H75C</td> <td>12</td> <td>LT GN</td> <td>2025422C1</td> <td>2025428C1</td> </tr> <tr> <td>B</td> <td>H11-GSM</td> <td>12</td> <td>WH</td> <td>2025422C1</td> <td>2025428C1</td> </tr> </tbody> </table>	CAV	CIR	GAUGE	COLOR	TERMINAL	SEAL/SLEEVE	A	H75C	12	LT GN	2025422C1	2025428C1	B	H11-GSM	12	WH	2025422C1	2025428C1																																																																																																						
CAV	CIR	GAUGE	COLOR	TERMINAL	SEAL/SLEEVE																																																																																																																				
A	H75C	12	LT GN	2025422C1	2025428C1																																																																																																																				
B	H11-GSM	12	WH	2025422C1	2025428C1																																																																																																																				
<p>SAT COMMUNICATION (5010) (LOCATED ON RIGHT SIDE, BACK OF PASSENGER DOOR)</p>  <p>CONNECTOR 3538634C1 BODY LOCK 3538636C1</p> <p>* W/ TRIP MASTER ** W/ XATA @ W/ QUALCOMM</p>	<table border="1" style="width:100%; border-collapse: collapse;"> <thead> <tr> <th>CAV</th> <th>CIR</th> <th>GAUGE</th> <th>COLOR</th> <th>TERMINAL</th> <th>SEAL/SLEEVE</th> </tr> </thead> <tbody> <tr><td>A*</td><td>H14SD</td><td>18</td><td>RD</td><td>1667742C1</td><td>1661872C1</td></tr> <tr><td>A**</td><td>H14ED</td><td>18</td><td>RD</td><td>1667742C1</td><td>1661872C1</td></tr> <tr><td>A@</td><td>H14EA</td><td>18</td><td>RD</td><td>1667742C1</td><td>1661872C1</td></tr> <tr><td>B@</td><td>H13EE</td><td>18</td><td>PK</td><td>1667742C1</td><td>1661872C1</td></tr> <tr><td>B*</td><td>H13SD</td><td>18</td><td>PK</td><td>1667742C1</td><td>1661872C1</td></tr> <tr><td>B</td><td>H13EF</td><td>18</td><td>PK</td><td>1667742C1</td><td>1661872C1</td></tr> <tr><td>C@</td><td>H3BD(-)</td><td>18</td><td>GY</td><td>1667742C1</td><td>1661872C1</td></tr> <tr><td>C**</td><td>H3BE(-)</td><td>18</td><td>GY</td><td>1667742C1</td><td>1661872C1</td></tr> <tr><td>C*</td><td>H98B</td><td>18</td><td>BK</td><td>1667742C1</td><td>1661872C1</td></tr> <tr><td>D@</td><td>H3BD(+)</td><td>18</td><td>DKBL</td><td>1667742C1</td><td>1661872C1</td></tr> <tr><td>D**</td><td>H3BE(+)</td><td>18</td><td>DKBL</td><td>1667742C1</td><td>1661872C1</td></tr> <tr><td>D*</td><td>H98A</td><td>18</td><td>BK</td><td>1667742C1</td><td>1661872C1</td></tr> <tr><td>E@</td><td>H98F</td><td>18</td><td>BK</td><td>1667742C1</td><td>1661872C1</td></tr> <tr><td>E**</td><td>H14EBA</td><td>18</td><td>RD</td><td>1667742C1</td><td>1661872C1</td></tr> <tr><td>F</td><td>H11-GSC</td><td>18</td><td>WH</td><td>1667742C1</td><td>1661872C1</td></tr> <tr><td>G</td><td>PLUG</td><td>-</td><td>-</td><td>-</td><td>2025431C1</td></tr> <tr><td>H</td><td>PLUG</td><td>-</td><td>-</td><td>-</td><td>2025431C1</td></tr> <tr><td>J</td><td>H70E</td><td>18</td><td>OR</td><td>1667742C1</td><td>1661872C1</td></tr> <tr><td>K</td><td>H50S</td><td>18</td><td>YL</td><td>1667742C1</td><td>1661872C1</td></tr> </tbody> </table>	CAV	CIR	GAUGE	COLOR	TERMINAL	SEAL/SLEEVE	A*	H14SD	18	RD	1667742C1	1661872C1	A**	H14ED	18	RD	1667742C1	1661872C1	A@	H14EA	18	RD	1667742C1	1661872C1	B@	H13EE	18	PK	1667742C1	1661872C1	B*	H13SD	18	PK	1667742C1	1661872C1	B	H13EF	18	PK	1667742C1	1661872C1	C@	H3BD(-)	18	GY	1667742C1	1661872C1	C**	H3BE(-)	18	GY	1667742C1	1661872C1	C*	H98B	18	BK	1667742C1	1661872C1	D@	H3BD(+)	18	DKBL	1667742C1	1661872C1	D**	H3BE(+)	18	DKBL	1667742C1	1661872C1	D*	H98A	18	BK	1667742C1	1661872C1	E@	H98F	18	BK	1667742C1	1661872C1	E**	H14EBA	18	RD	1667742C1	1661872C1	F	H11-GSC	18	WH	1667742C1	1661872C1	G	PLUG	-	-	-	2025431C1	H	PLUG	-	-	-	2025431C1	J	H70E	18	OR	1667742C1	1661872C1	K	H50S	18	YL	1667742C1	1661872C1
CAV	CIR	GAUGE	COLOR	TERMINAL	SEAL/SLEEVE																																																																																																																				
A*	H14SD	18	RD	1667742C1	1661872C1																																																																																																																				
A**	H14ED	18	RD	1667742C1	1661872C1																																																																																																																				
A@	H14EA	18	RD	1667742C1	1661872C1																																																																																																																				
B@	H13EE	18	PK	1667742C1	1661872C1																																																																																																																				
B*	H13SD	18	PK	1667742C1	1661872C1																																																																																																																				
B	H13EF	18	PK	1667742C1	1661872C1																																																																																																																				
C@	H3BD(-)	18	GY	1667742C1	1661872C1																																																																																																																				
C**	H3BE(-)	18	GY	1667742C1	1661872C1																																																																																																																				
C*	H98B	18	BK	1667742C1	1661872C1																																																																																																																				
D@	H3BD(+)	18	DKBL	1667742C1	1661872C1																																																																																																																				
D**	H3BE(+)	18	DKBL	1667742C1	1661872C1																																																																																																																				
D*	H98A	18	BK	1667742C1	1661872C1																																																																																																																				
E@	H98F	18	BK	1667742C1	1661872C1																																																																																																																				
E**	H14EBA	18	RD	1667742C1	1661872C1																																																																																																																				
F	H11-GSC	18	WH	1667742C1	1661872C1																																																																																																																				
G	PLUG	-	-	-	2025431C1																																																																																																																				
H	PLUG	-	-	-	2025431C1																																																																																																																				
J	H70E	18	OR	1667742C1	1661872C1																																																																																																																				
K	H50S	18	YL	1667742C1	1661872C1																																																																																																																				
<p>REMOTE RADIO &amp; TWEETER (5011M / 5011F) (LOCATED ON LEFT SIDE - BACK OF DOOR)</p>  <p>CONNECTOR 3540612C1 BODY LOCK 3540614C1</p>	 <p>CONNECTOR 3540613C1 BODY LOCK 3540615C1</p> <table border="1" style="width:100%; border-collapse: collapse;"> <thead> <tr> <th>CAV</th> <th>CIR</th> <th>GAUGE</th> <th>COLOR</th> <th>TERMINAL</th> </tr> </thead> <tbody> <tr><td>A</td><td>A86R</td><td>18</td><td>LTGN</td><td>1661262C1</td></tr> <tr><td>B</td><td>A86AE</td><td>18</td><td>LTGN</td><td>1661262C1</td></tr> <tr><td>C</td><td>A86(+)</td><td>18</td><td>YL</td><td>1661262C1</td></tr> <tr><td>C*</td><td>A86D(+)</td><td>18</td><td>YL</td><td>1661262C1</td></tr> <tr><td>D</td><td>A86(-)</td><td>18</td><td>GN</td><td>1661262C1</td></tr> <tr><td>D*</td><td>A86D(-)</td><td>18</td><td>GN</td><td>1661262C1</td></tr> <tr><td>E</td><td>A86F</td><td>18</td><td>LTGN</td><td>1661262C1</td></tr> <tr><td>F</td><td>A86AR</td><td>18</td><td>LTGN</td><td>1661262C1</td></tr> <tr><td>G</td><td>A86AS</td><td>18</td><td>LTGN</td><td>1661262C1</td></tr> <tr><td>H</td><td>A86AT</td><td>18</td><td>LTGN</td><td>1661262C1</td></tr> <tr><td>J</td><td>A86AU</td><td>18</td><td>LTGN</td><td>1661262C1</td></tr> <tr><td>K</td><td>-</td><td>-</td><td>-</td><td>-</td></tr> </tbody> </table> <p>* W/DRIVER DISPLAY</p>	CAV	CIR	GAUGE	COLOR	TERMINAL	A	A86R	18	LTGN	1661262C1	B	A86AE	18	LTGN	1661262C1	C	A86(+)	18	YL	1661262C1	C*	A86D(+)	18	YL	1661262C1	D	A86(-)	18	GN	1661262C1	D*	A86D(-)	18	GN	1661262C1	E	A86F	18	LTGN	1661262C1	F	A86AR	18	LTGN	1661262C1	G	A86AS	18	LTGN	1661262C1	H	A86AT	18	LTGN	1661262C1	J	A86AU	18	LTGN	1661262C1	K	-	-	-	-																																																							
CAV	CIR	GAUGE	COLOR	TERMINAL																																																																																																																					
A	A86R	18	LTGN	1661262C1																																																																																																																					
B	A86AE	18	LTGN	1661262C1																																																																																																																					
C	A86(+)	18	YL	1661262C1																																																																																																																					
C*	A86D(+)	18	YL	1661262C1																																																																																																																					
D	A86(-)	18	GN	1661262C1																																																																																																																					
D*	A86D(-)	18	GN	1661262C1																																																																																																																					
E	A86F	18	LTGN	1661262C1																																																																																																																					
F	A86AR	18	LTGN	1661262C1																																																																																																																					
G	A86AS	18	LTGN	1661262C1																																																																																																																					
H	A86AT	18	LTGN	1661262C1																																																																																																																					
J	A86AU	18	LTGN	1661262C1																																																																																																																					
K	-	-	-	-																																																																																																																					
<table border="1" style="width:100%; border-collapse: collapse;"> <thead> <tr> <th>CHK</th> <th>DATE</th> <th>CHANGE</th> <th>REV</th> <th>REFERENCE</th> <th>DRAWN</th> <th>NAME</th> </tr> </thead> <tbody> <tr> <td>DLV1</td> <td>19NOV09</td> <td>RVSD CONN 5011M, ADDED</td> <td>A</td> <td>63656A</td> <td>U00SLK3</td> <td>CIRCUIT DIAGRAM, PROSTAR, LONESTAR</td> </tr> <tr> <td></td> <td></td> <td>DRIVER DISPLAY EFFECTS.</td> <td></td> <td></td> <td>51089U</td> <td></td> </tr> </tbody> </table>	CHK	DATE	CHANGE	REV	REFERENCE	DRAWN	NAME	DLV1	19NOV09	RVSD CONN 5011M, ADDED	A	63656A	U00SLK3	CIRCUIT DIAGRAM, PROSTAR, LONESTAR			DRIVER DISPLAY EFFECTS.			51089U		<table border="1" style="width:100%; border-collapse: collapse;"> <thead> <tr> <th>DATE</th> <th>FURT. NO.</th> <th>SHEET</th> </tr> </thead> <tbody> <tr> <td>07NOV08</td> <td>AE08055906</td> <td>69B</td> </tr> </tbody> </table>	DATE	FURT. NO.	SHEET	07NOV08	AE08055906	69B																																																																																													
CHK	DATE	CHANGE	REV	REFERENCE	DRAWN	NAME																																																																																																																			
DLV1	19NOV09	RVSD CONN 5011M, ADDED	A	63656A	U00SLK3	CIRCUIT DIAGRAM, PROSTAR, LONESTAR																																																																																																																			
		DRIVER DISPLAY EFFECTS.			51089U																																																																																																																				
DATE	FURT. NO.	SHEET																																																																																																																							
07NOV08	AE08055906	69B																																																																																																																							

Figure 315 Connector Composites (5009), (5010), (5011M/5011F)

14.87. CONNECTOR COMPOSITES (5012), (5013), (5014), (5015), (5020), (5031), P. 70

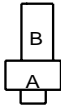
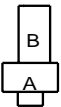

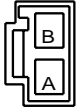


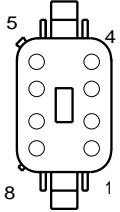
INTERNATIONAL TRUCK AND ENGINE CORPORATION <small>THIS PRINT IS PROVIDED ON A RESTRICTED BASIS AND IS NOT TO BE USED IN ANY WAY DETRIMENTAL TO THE INTEREST OF INTERNATIONAL TRUCK AND ENGINE CORPORATION.</small>		ELECTRICAL CIRCUIT DIAGRAM CHAPTER 14 CONNECTOR BODY COMPOSITE - MATING VIEW SHOWN																																												
<p>LONG SLEEPER SKY / RISE 12V POWER SOURCE (5012) (LOCATED IN RIGHT SIDE OF SLEEPER)</p>  <p>CONNECTOR 0872291R1 BODY LOCK 3557682C1</p> <table border="1" style="width:100%; border-collapse: collapse;"> <thead> <tr> <th>CAV</th> <th>CIR</th> <th>GAUGE</th> <th>COLOR</th> <th>TERMINAL</th> </tr> </thead> <tbody> <tr> <td>A</td> <td>H86-GSB</td> <td>16</td> <td>WH</td> <td>0188396R1</td> </tr> <tr> <td>A*</td> <td>H63-SCA</td> <td>18</td> <td>DKBL</td> <td>0573092C1</td> </tr> <tr> <td>B</td> <td>H86SBB</td> <td>16</td> <td>LTGN</td> <td>0188396R1</td> </tr> </tbody> </table> <p style="text-align: center;"><small>* W/ LONESTAR</small></p>	CAV	CIR	GAUGE	COLOR	TERMINAL	A	H86-GSB	16	WH	0188396R1	A*	H63-SCA	18	DKBL	0573092C1	B	H86SBB	16	LTGN	0188396R1	<p>LONG SLEEPER SKY / RISE 12V POWER SOURCE (5013) (LOCATED IN RIGHT SIDE OF SLEEPER)</p>  <p>CONNECTOR 0872291R1 BODY LOCK 3557682C1</p> <table border="1" style="width:100%; border-collapse: collapse;"> <thead> <tr> <th>CAV</th> <th>CIR</th> <th>GAUGE</th> <th>COLOR</th> <th>TERMINAL</th> </tr> </thead> <tbody> <tr> <td>A</td> <td>H86-GSB</td> <td>16</td> <td>WH</td> <td>0188396R1</td> </tr> <tr> <td>A*</td> <td>H86-GSM</td> <td>16</td> <td>WH</td> <td>0188396R1</td> </tr> <tr> <td>B</td> <td>H86SBB</td> <td>16</td> <td>LTGN</td> <td>0188396R1</td> </tr> <tr> <td>B*</td> <td>H86-SBM</td> <td>18</td> <td>LTGN</td> <td>0879630R1</td> </tr> </tbody> </table> <p style="text-align: center;"><small>* W/ LONESTAR</small></p>	CAV	CIR	GAUGE	COLOR	TERMINAL	A	H86-GSB	16	WH	0188396R1	A*	H86-GSM	16	WH	0188396R1	B	H86SBB	16	LTGN	0188396R1	B*	H86-SBM	18	LTGN	0879630R1
CAV	CIR	GAUGE	COLOR	TERMINAL																																										
A	H86-GSB	16	WH	0188396R1																																										
A*	H63-SCA	18	DKBL	0573092C1																																										
B	H86SBB	16	LTGN	0188396R1																																										
CAV	CIR	GAUGE	COLOR	TERMINAL																																										
A	H86-GSB	16	WH	0188396R1																																										
A*	H86-GSM	16	WH	0188396R1																																										
B	H86SBB	16	LTGN	0188396R1																																										
B*	H86-SBM	18	LTGN	0879630R1																																										
<p>PASS UPPER CABINET (5014) (LOCATED IN RIGHT SIDE OF SLEEPER) (W/ LONESTAR)</p>  <p>CONNECTOR 3825188C1</p> <table border="1" style="width:100%; border-collapse: collapse;"> <thead> <tr> <th>CAV</th> <th>CIR</th> <th>GAUGE</th> <th>COLOR</th> <th>TERMINAL</th> </tr> </thead> <tbody> <tr> <td>1</td> <td>H63UB</td> <td>18</td> <td>DKBL</td> <td>3825382C1</td> </tr> <tr> <td>2</td> <td>H63-GUB</td> <td>18</td> <td>WH</td> <td>3825382C1</td> </tr> <tr> <td>3</td> <td>H86-BBA</td> <td>18</td> <td>LTGN</td> <td>3825382C1</td> </tr> <tr> <td>4</td> <td>H86-BBB</td> <td>18</td> <td>LTGN</td> <td>3825382C1</td> </tr> </tbody> </table>	CAV	CIR	GAUGE	COLOR	TERMINAL	1	H63UB	18	DKBL	3825382C1	2	H63-GUB	18	WH	3825382C1	3	H86-BBA	18	LTGN	3825382C1	4	H86-BBB	18	LTGN	3825382C1	<p>UNDER BUNK LIGHT LEFT (5015) (LOCATED IN LEFT SIDE OF SLEEPER) (W/ LONESTAR)</p>  <p>CONNECTOR 1669973C1</p> <table border="1" style="width:100%; border-collapse: collapse;"> <thead> <tr> <th>CAV</th> <th>CIR</th> <th>GAUGE</th> <th>COLOR</th> <th>TERMINAL</th> </tr> </thead> <tbody> <tr> <td>A</td> <td>H63-SJA</td> <td>18</td> <td>DKBL</td> <td>1661212C1</td> </tr> <tr> <td>B</td> <td>H63-GSB</td> <td>18</td> <td>WH</td> <td>1661212C1</td> </tr> </tbody> </table>	CAV	CIR	GAUGE	COLOR	TERMINAL	A	H63-SJA	18	DKBL	1661212C1	B	H63-GSB	18	WH	1661212C1					
CAV	CIR	GAUGE	COLOR	TERMINAL																																										
1	H63UB	18	DKBL	3825382C1																																										
2	H63-GUB	18	WH	3825382C1																																										
3	H86-BBA	18	LTGN	3825382C1																																										
4	H86-BBB	18	LTGN	3825382C1																																										
CAV	CIR	GAUGE	COLOR	TERMINAL																																										
A	H63-SJA	18	DKBL	1661212C1																																										
B	H63-GSB	18	WH	1661212C1																																										
<p>SKY RISE UPPER BUNK POWER SOURCE (5015) (W/ PROSTAR)</p>  <p>CONNECTOR 3613000C1</p> <table border="1" style="width:100%; border-collapse: collapse;"> <thead> <tr> <th>CAV</th> <th>CIR</th> <th>GAUGE</th> <th>COLOR</th> <th>TERMINAL</th> </tr> </thead> <tbody> <tr> <td>A</td> <td>H86M</td> <td>16</td> <td>LT GN</td> <td>3534165C1</td> </tr> <tr> <td>B</td> <td>-</td> <td>-</td> <td>-</td> <td>-</td> </tr> <tr> <td>C</td> <td>H86-GJJ</td> <td>16</td> <td>WH</td> <td>3534165C1</td> </tr> </tbody> </table>	CAV	CIR	GAUGE	COLOR	TERMINAL	A	H86M	16	LT GN	3534165C1	B	-	-	-	-	C	H86-GJJ	16	WH	3534165C1	<p>UNDER BUNK LIGHT RIGHT (5020) (LOCATED IN RIGHT SIDE OF SLEEPER) (W/ LONESTAR)</p>  <p>CONNECTOR 1669973C1</p> <table border="1" style="width:100%; border-collapse: collapse;"> <thead> <tr> <th>CAV</th> <th>CIR</th> <th>GAUGE</th> <th>COLOR</th> <th>TERMINAL</th> </tr> </thead> <tbody> <tr> <td>A</td> <td>H63-SJB</td> <td>18</td> <td>DKBL</td> <td>1661212C1</td> </tr> <tr> <td>B</td> <td>H63-GSB</td> <td>18</td> <td>WH</td> <td>1661212C1</td> </tr> </tbody> </table>	CAV	CIR	GAUGE	COLOR	TERMINAL	A	H63-SJB	18	DKBL	1661212C1	B	H63-GSB	18	WH	1661212C1										
CAV	CIR	GAUGE	COLOR	TERMINAL																																										
A	H86M	16	LT GN	3534165C1																																										
B	-	-	-	-																																										
C	H86-GJJ	16	WH	3534165C1																																										
CAV	CIR	GAUGE	COLOR	TERMINAL																																										
A	H63-SJB	18	DKBL	1661212C1																																										
B	H63-GSB	18	WH	1661212C1																																										
<p>APU/PDC (5031) (LOCATED UNDER BUNK)</p>  <p>CONNECTOR 3674957C1 BODY LOCK 3534766C1</p> <table border="1" style="width:100%; border-collapse: collapse;"> <thead> <tr> <th>CAV</th> <th>CIR</th> <th>GAUGE</th> <th>COLOR</th> <th>TERMINAL</th> </tr> </thead> <tbody> <tr> <td>1</td> <td>H77NA</td> <td>18</td> <td>LTGN</td> <td>1680205C1</td> </tr> <tr> <td>2</td> <td>H77NB</td> <td>18</td> <td>LTGN</td> <td>1680205C1</td> </tr> <tr> <td>3</td> <td>PLUG</td> <td>-</td> <td>-</td> <td>0453133C1</td> </tr> <tr> <td>4</td> <td>H5MB(-)</td> <td>18</td> <td>GN</td> <td>1680205C1</td> </tr> <tr> <td>5</td> <td>H5MB(+)</td> <td>18</td> <td>YL</td> <td>1680205C1</td> </tr> <tr> <td>6</td> <td>PLUG</td> <td>-</td> <td>-</td> <td>0453133C1</td> </tr> <tr> <td>7</td> <td>PLUG</td> <td>-</td> <td>-</td> <td>0453133C1</td> </tr> <tr> <td>8</td> <td>PLUG</td> <td>-</td> <td>-</td> <td>0453133C1</td> </tr> </tbody> </table>		CAV	CIR	GAUGE	COLOR	TERMINAL	1	H77NA	18	LTGN	1680205C1	2	H77NB	18	LTGN	1680205C1	3	PLUG	-	-	0453133C1	4	H5MB(-)	18	GN	1680205C1	5	H5MB(+)	18	YL	1680205C1	6	PLUG	-	-	0453133C1	7	PLUG	-	-	0453133C1	8	PLUG	-	-	0453133C1
CAV	CIR	GAUGE	COLOR	TERMINAL																																										
1	H77NA	18	LTGN	1680205C1																																										
2	H77NB	18	LTGN	1680205C1																																										
3	PLUG	-	-	0453133C1																																										
4	H5MB(-)	18	GN	1680205C1																																										
5	H5MB(+)	18	YL	1680205C1																																										
6	PLUG	-	-	0453133C1																																										
7	PLUG	-	-	0453133C1																																										
8	PLUG	-	-	0453133C1																																										
<table border="1" style="width:100%; border-collapse: collapse;"> <tr> <th>CHK</th> <th>DATE</th> <th>CHANGE</th> <th>REV</th> <th>REFERENCE</th> </tr> <tr> <td>CNA1</td> <td>14JAN09</td> <td>ADDED LONESTAR EFFECT</td> <td>D</td> <td>61254R</td> </tr> </table>	CHK	DATE	CHANGE	REV	REFERENCE	CNA1	14JAN09	ADDED LONESTAR EFFECT	D	61254R	<table border="1" style="width:100%; border-collapse: collapse;"> <tr> <th>RELEASE NO.</th> <th>DATE</th> <th>PART NO.</th> <th>SHEET</th> </tr> <tr> <td>59637L</td> <td>07SEP06</td> <td>AE08055906</td> <td>070</td> </tr> </table>	RELEASE NO.	DATE	PART NO.	SHEET	59637L	07SEP06	AE08055906	070	<table border="1" style="width:100%; border-collapse: collapse;"> <tr> <th>DRAWN</th> <th>NAME</th> </tr> <tr> <td>U00K640</td> <td>CIRCUIT DIAGRAM, PROSTAR, LONESTAR</td> </tr> </table>	DRAWN	NAME	U00K640	CIRCUIT DIAGRAM, PROSTAR, LONESTAR																						
CHK	DATE	CHANGE	REV	REFERENCE																																										
CNA1	14JAN09	ADDED LONESTAR EFFECT	D	61254R																																										
RELEASE NO.	DATE	PART NO.	SHEET																																											
59637L	07SEP06	AE08055906	070																																											
DRAWN	NAME																																													
U00K640	CIRCUIT DIAGRAM, PROSTAR, LONESTAR																																													

Figure 316 Connector Composites (5012), (5013), (5014), (5015), (5020), (5031)

14.88. CONNECTOR COMPOSITES (5033), (5034), (5035/5035A), (5100), (5101), P. 70A

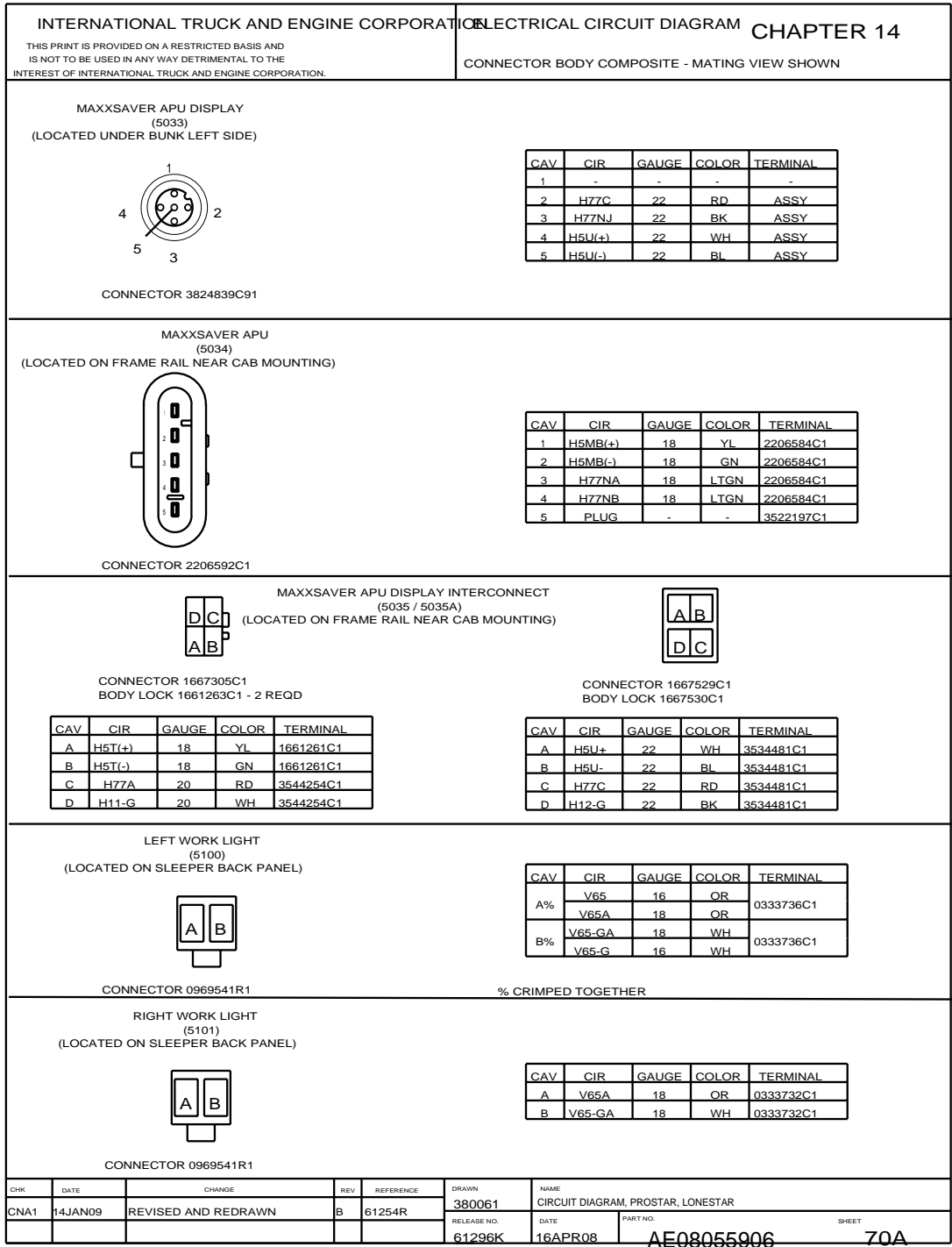


Figure 317 Connector Composites (5033), (5034), (5035/5035A), (5100), (5101)

14.89. CONNECTOR COMPOSITES (5102), (5103), (5104), (5105), P. 71

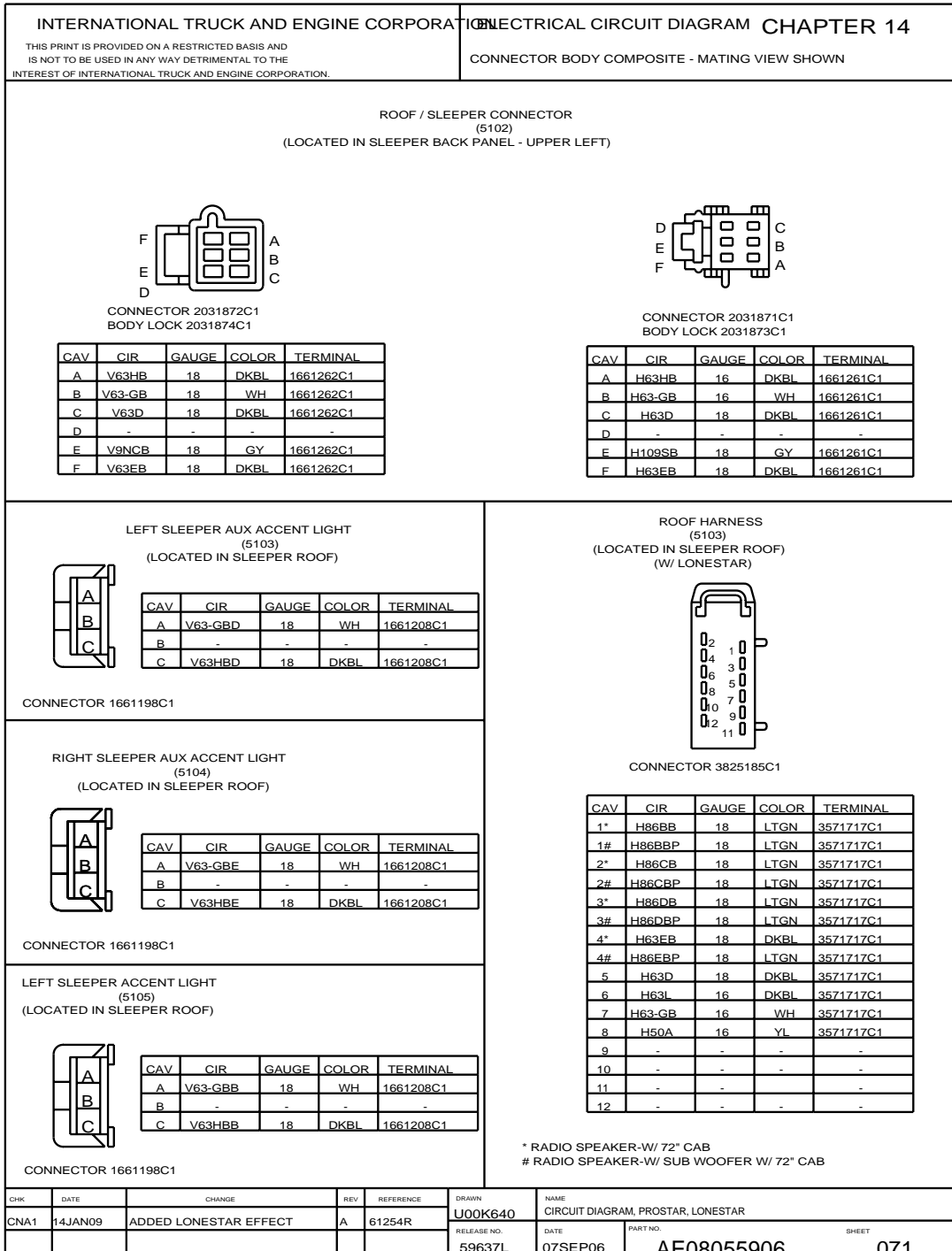


Figure 318 Connector Composites (5102), (5103), (5104), (5105)

14.90. CONNECTOR COMPOSITES (5106), (5107), (5109), (5110), (5111), P. 72






INTERNATIONAL TRUCK AND ENGINE CORPORATION				ELECTRICAL CIRCUIT DIAGRAM CHAPTER 14																												
THIS PRINT IS PROVIDED ON A RESTRICTED BASIS AND IS NOT TO BE USED IN ANY WAY DETRIMENTAL TO THE INTEREST OF INTERNATIONAL TRUCK AND ENGINE CORPORATION.				CONNECTOR BODY COMPOSITE - MATING VIEW SHOWN																												
<p>RIGHT SLEEPER ACCENT LIGHT (5106) (LOCATED IN SLEEPER ROOF) (W/ PROSTAR)</p>  <p>CONNECTOR 1661198C1</p>				<table border="1"> <thead> <tr> <th>CAV</th> <th>CIR</th> <th>GAUGE</th> <th>COLOR</th> <th>TERMINAL</th> </tr> </thead> <tbody> <tr> <td>A</td> <td>V63-GBC</td> <td>18</td> <td>WH</td> <td>1661208C1</td> </tr> <tr> <td>B</td> <td>-</td> <td>-</td> <td>-</td> <td>-</td> </tr> <tr> <td>C</td> <td>V63HBC</td> <td>18</td> <td>DKBL</td> <td>1661208C1</td> </tr> </tbody> </table>				CAV	CIR	GAUGE	COLOR	TERMINAL	A	V63-GBC	18	WH	1661208C1	B	-	-	-	-	C	V63HBC	18	DKBL	1661208C1					
CAV	CIR	GAUGE	COLOR	TERMINAL																												
A	V63-GBC	18	WH	1661208C1																												
B	-	-	-	-																												
C	V63HBC	18	DKBL	1661208C1																												
<p>SLEEPER DOME LIGHT (5107) (LOCATED IN SLEEPER ROOF) (W/ PROSTAR)</p>  <p>CONNECTOR 1667305C1 BODY LOCK 1661263C1</p>				<table border="1"> <thead> <tr> <th>CAV</th> <th>CIR</th> <th>GAUGE</th> <th>COLOR</th> <th>TERMINAL</th> </tr> </thead> <tbody> <tr> <td>A</td> <td>V63D</td> <td>18</td> <td>DKBL</td> <td>1661261C1</td> </tr> <tr> <td>B</td> <td>V63-GA</td> <td>18</td> <td>WH</td> <td>1661261C1</td> </tr> <tr> <td>C</td> <td>V63EB</td> <td>18</td> <td>DKBL</td> <td>1661261C1</td> </tr> <tr> <td>D</td> <td>V9NCB</td> <td>18</td> <td>GY</td> <td>1661261C1</td> </tr> </tbody> </table>				CAV	CIR	GAUGE	COLOR	TERMINAL	A	V63D	18	DKBL	1661261C1	B	V63-GA	18	WH	1661261C1	C	V63EB	18	DKBL	1661261C1	D	V9NCB	18	GY	1661261C1
CAV	CIR	GAUGE	COLOR	TERMINAL																												
A	V63D	18	DKBL	1661261C1																												
B	V63-GA	18	WH	1661261C1																												
C	V63EB	18	DKBL	1661261C1																												
D	V9NCB	18	GY	1661261C1																												
<p>WARDROBE CABINATE (5109) (LOCATED ON LEFT SIDE BY WARDROBE CABINET)</p>  <p>CONNECTOR 1661259C1 BODY LOCK 1661263C1</p>				<table border="1"> <thead> <tr> <th>CAV</th> <th>CIR</th> <th>GAUGE</th> <th>COLOR</th> <th>TERMINAL</th> </tr> </thead> <tbody> <tr> <td>A</td> <td>H63K</td> <td>18</td> <td>DKBL</td> <td>1661261C1</td> </tr> <tr> <td>B</td> <td>H63-GK</td> <td>18</td> <td>WH</td> <td>1661261C1</td> </tr> </tbody> </table>				CAV	CIR	GAUGE	COLOR	TERMINAL	A	H63K	18	DKBL	1661261C1	B	H63-GK	18	WH	1661261C1										
CAV	CIR	GAUGE	COLOR	TERMINAL																												
A	H63K	18	DKBL	1661261C1																												
B	H63-GK	18	WH	1661261C1																												
<p>LEFT LUGGAGE LIGHT (5110) (LOCATED UNDER BUNK - LEFT SIDE)</p>  <p>CONNECTOR 1669973C1</p>				<table border="1"> <thead> <tr> <th>CAV</th> <th>CIR</th> <th>GAUGE</th> <th>COLOR</th> <th>TERMINAL</th> </tr> </thead> <tbody> <tr> <td>A</td> <td>H63SJA</td> <td>18</td> <td>DKBL</td> <td>1661212C1</td> </tr> <tr> <td>B</td> <td>H63-GSB</td> <td>18</td> <td>WH</td> <td>1661212C1</td> </tr> </tbody> </table>				CAV	CIR	GAUGE	COLOR	TERMINAL	A	H63SJA	18	DKBL	1661212C1	B	H63-GSB	18	WH	1661212C1										
CAV	CIR	GAUGE	COLOR	TERMINAL																												
A	H63SJA	18	DKBL	1661212C1																												
B	H63-GSB	18	WH	1661212C1																												
<p>RIGHT LUGGAGE LIGHT (5111) (LOCATED UNDER BUNK - RIGHT SIDE)</p>  <p>CONNECTOR 1669973C1</p>				<table border="1"> <thead> <tr> <th>CAV</th> <th>CIR</th> <th>GAUGE</th> <th>COLOR</th> <th>TERMINAL</th> </tr> </thead> <tbody> <tr> <td>A</td> <td>H63SJB</td> <td>18</td> <td>DKBL</td> <td>1661212C1</td> </tr> <tr> <td>B</td> <td>H63-GSC</td> <td>18</td> <td>WH</td> <td>1661212C1</td> </tr> </tbody> </table>				CAV	CIR	GAUGE	COLOR	TERMINAL	A	H63SJB	18	DKBL	1661212C1	B	H63-GSC	18	WH	1661212C1										
CAV	CIR	GAUGE	COLOR	TERMINAL																												
A	H63SJB	18	DKBL	1661212C1																												
B	H63-GSC	18	WH	1661212C1																												
CHK	DATE	CHANGE	REV	REFERENCE	DRAWN	NAME																										
CNA1	14JAN09	ADDED LONESTAR EFFECT	A	61254R	U00K640	CIRCUIT DIAGRAM, PROSTAR, LONESTAR																										
					RELEASE NO.	DATE																										
					59637L	07SEP06																										
						PART NO.																										
						AE08055906																										
						SHEET																										
						072																										

Figure 319 Connector Composites (5106), (5107), (5109), (5110), (5111)

14.91. CONNECTOR COMPOSITES (5117), (5118), (5119), P. 73

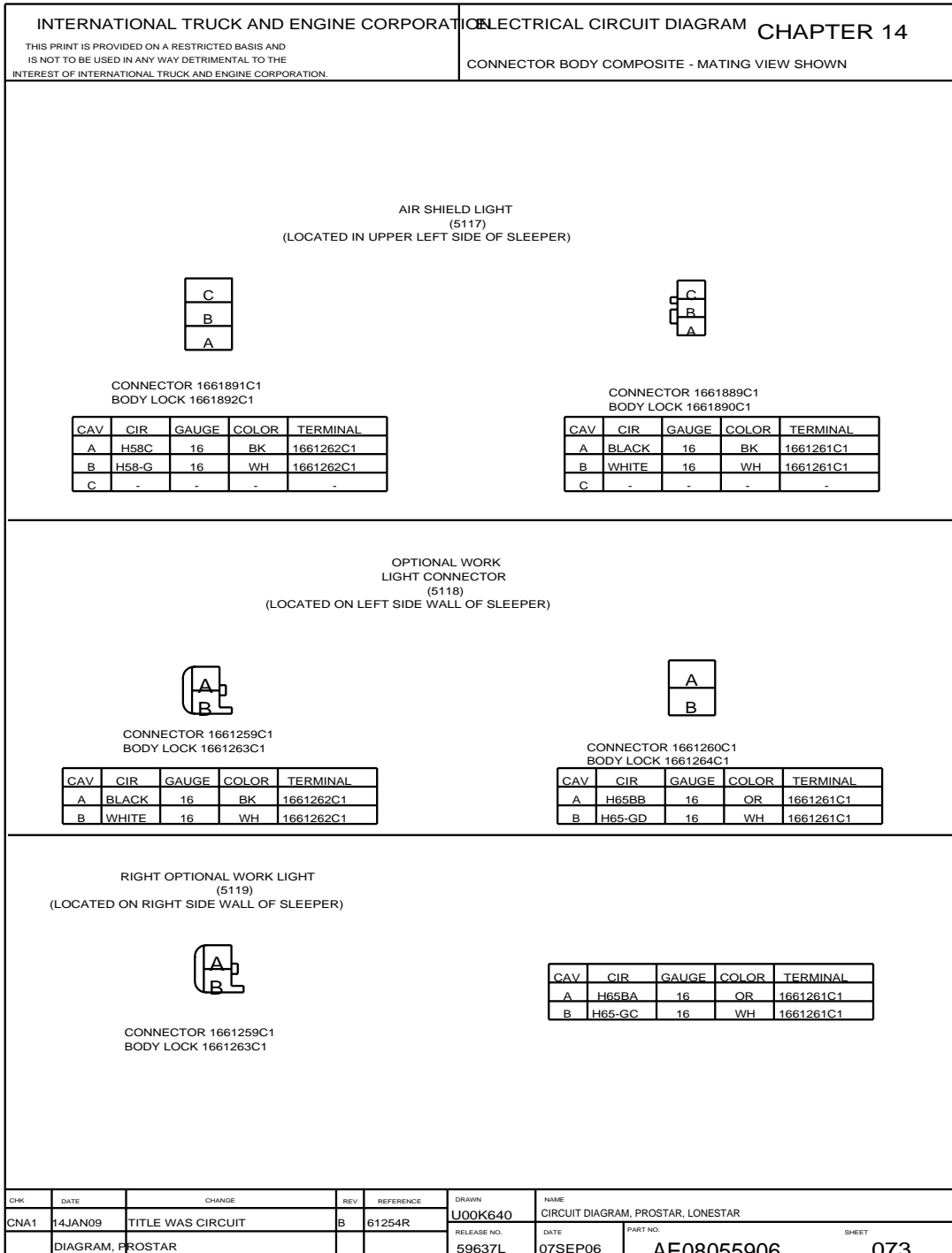


Figure 320 Connector Composites (5117), (5118), (5119)

14.92. CONNECTOR COMPOSITES (5123), (5124), (5125), P. 74

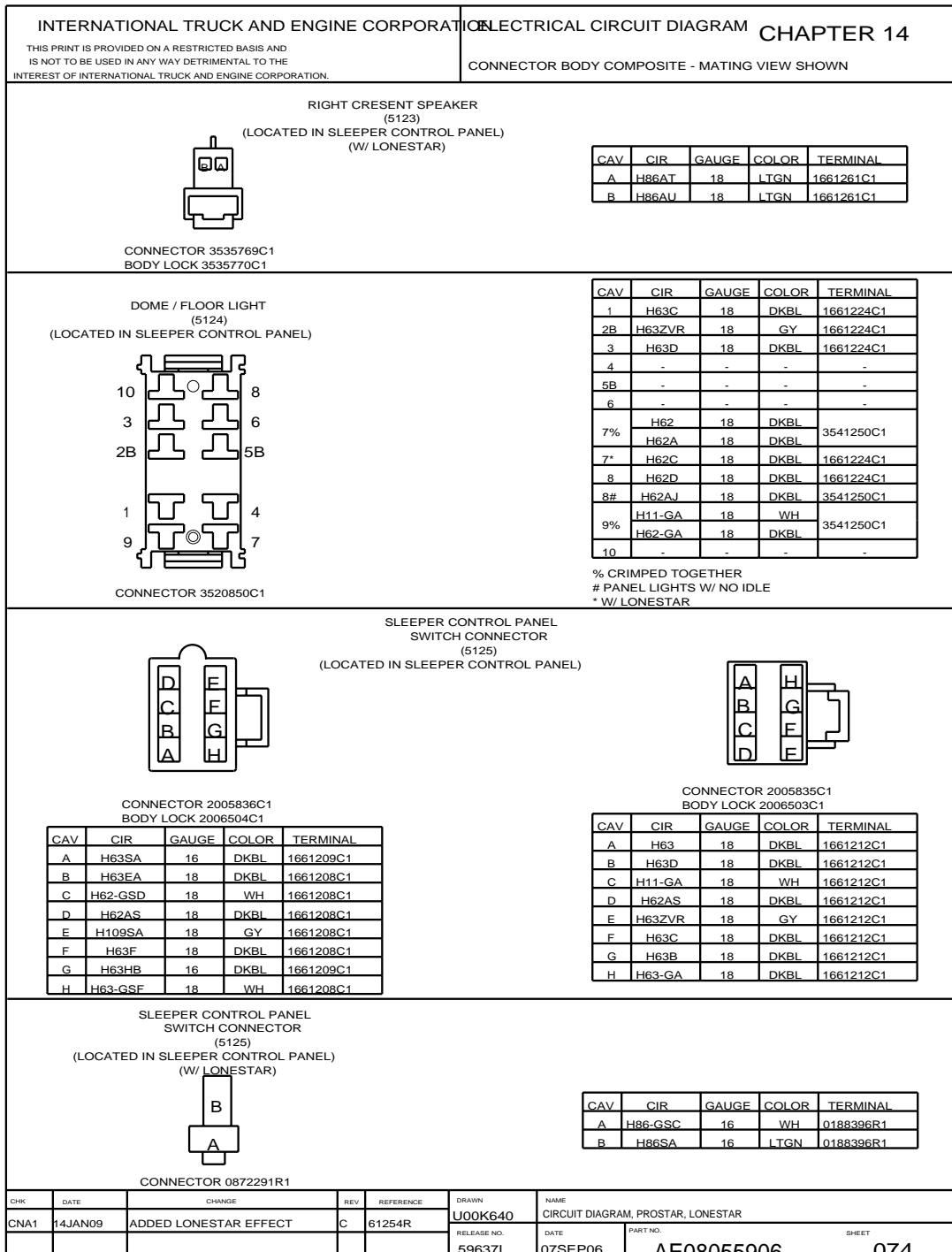


Figure 321 Connector Composites (5123), (5124), (5125)

14.93. CONNECTOR COMPOSITES (5126), (5127), (5128), (5129), (5130), P. 75

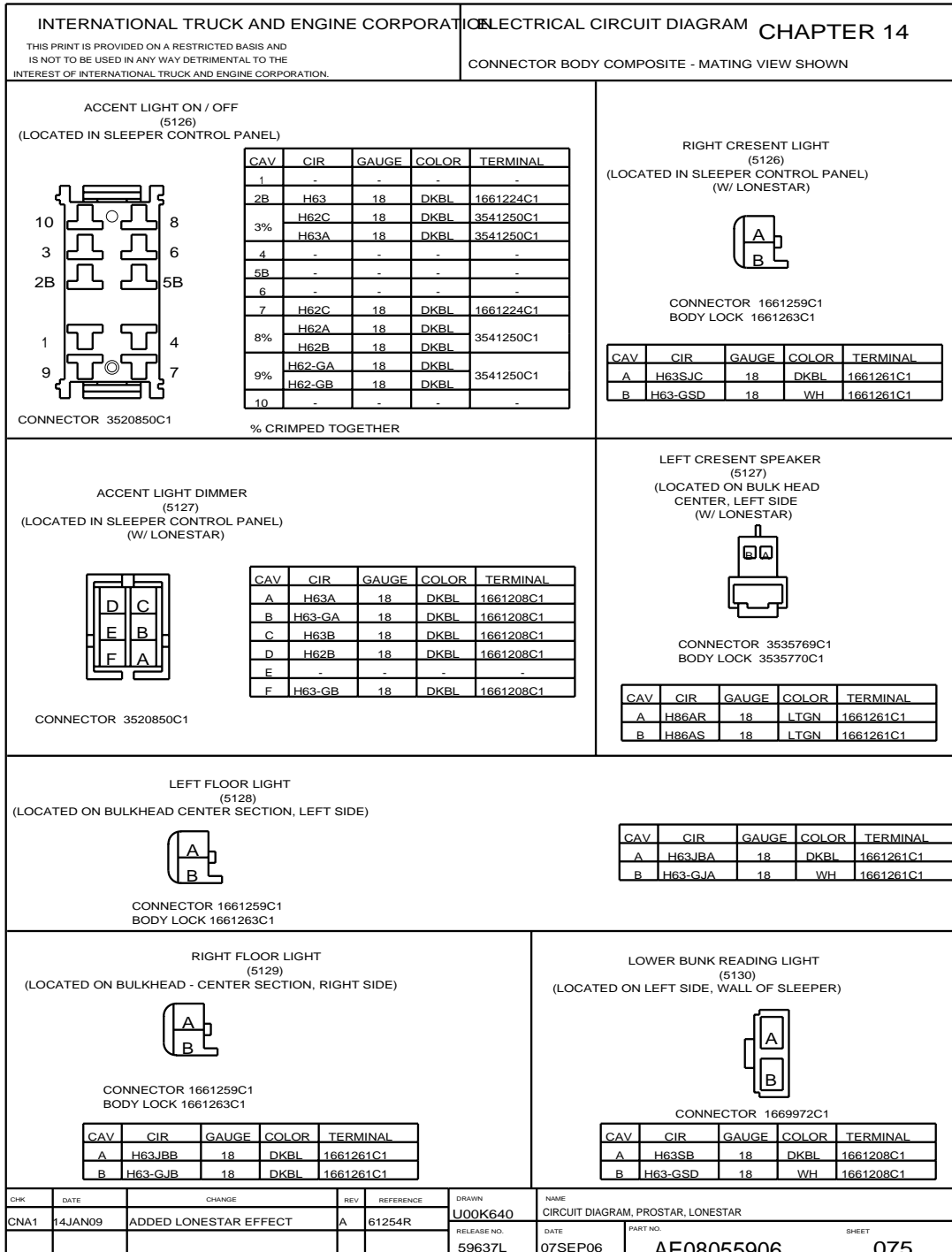


Figure 322 Connector Composites (5126), (5127), (5128), (5129), (5130)

14.94. CONNECTOR COMPOSITES (5130), (5134), P. 75A

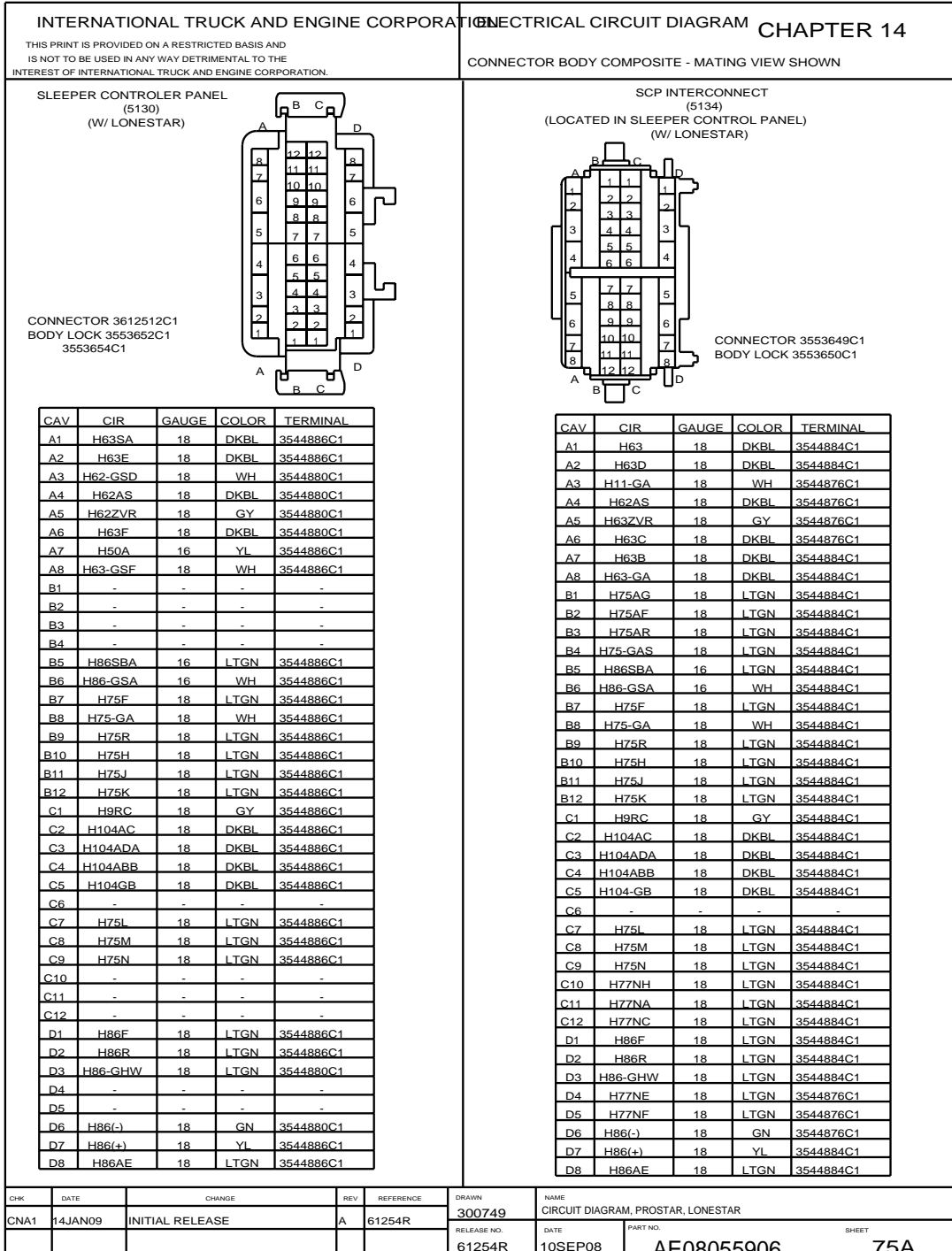


Figure 323 Connector Composites (5130), (5134)

14.95. CONNECTOR COMPOSITES (5131), (5134), (5135), (5135M), (5136), (5200), (5201), P. 76

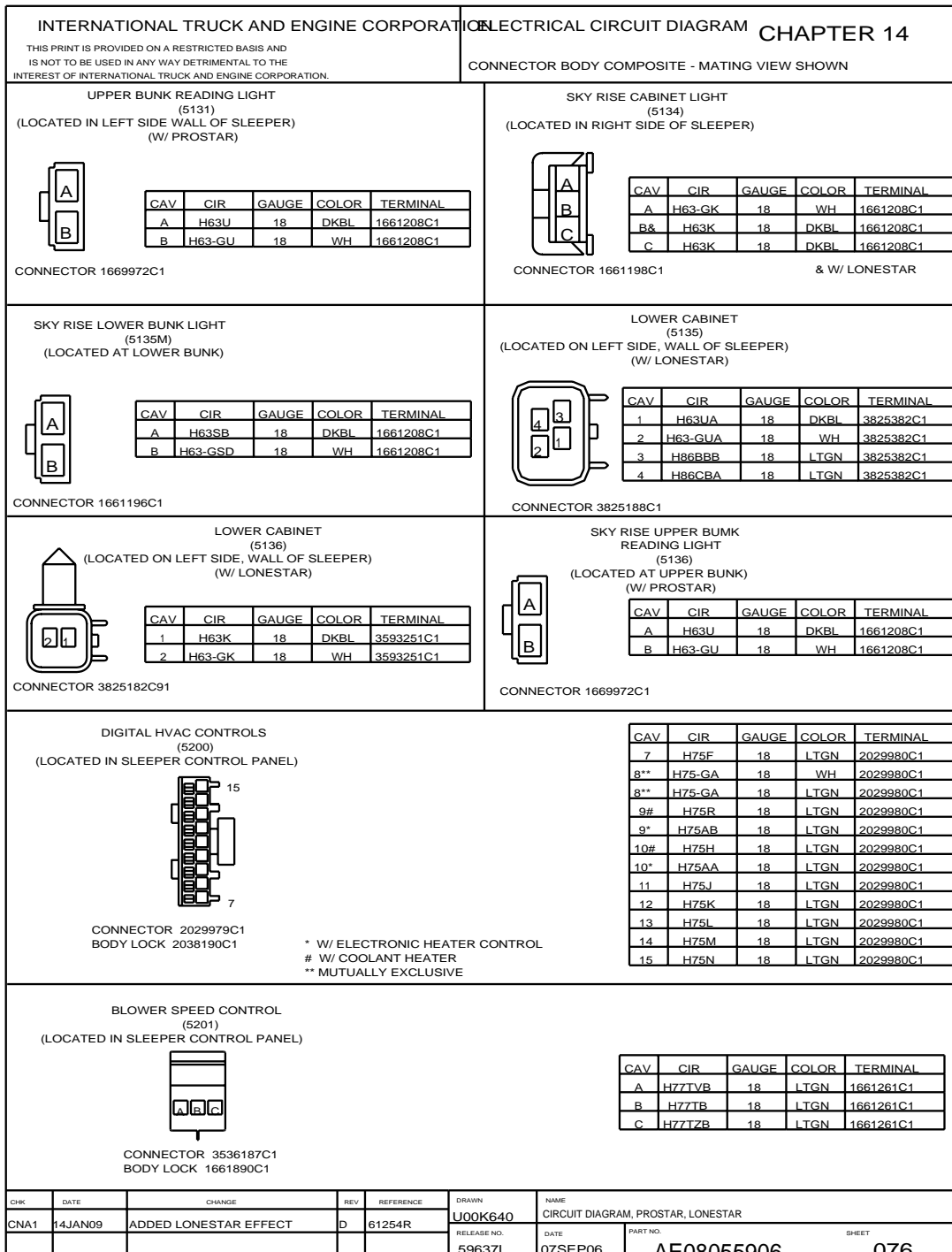


Figure 324 Connector Composites (5131), (5134), (5135), (5135M), (5136), (5200), (5201)

14.96. CONNECTOR COMPOSITES (5202), (5210), (5212), (5213), P. 77

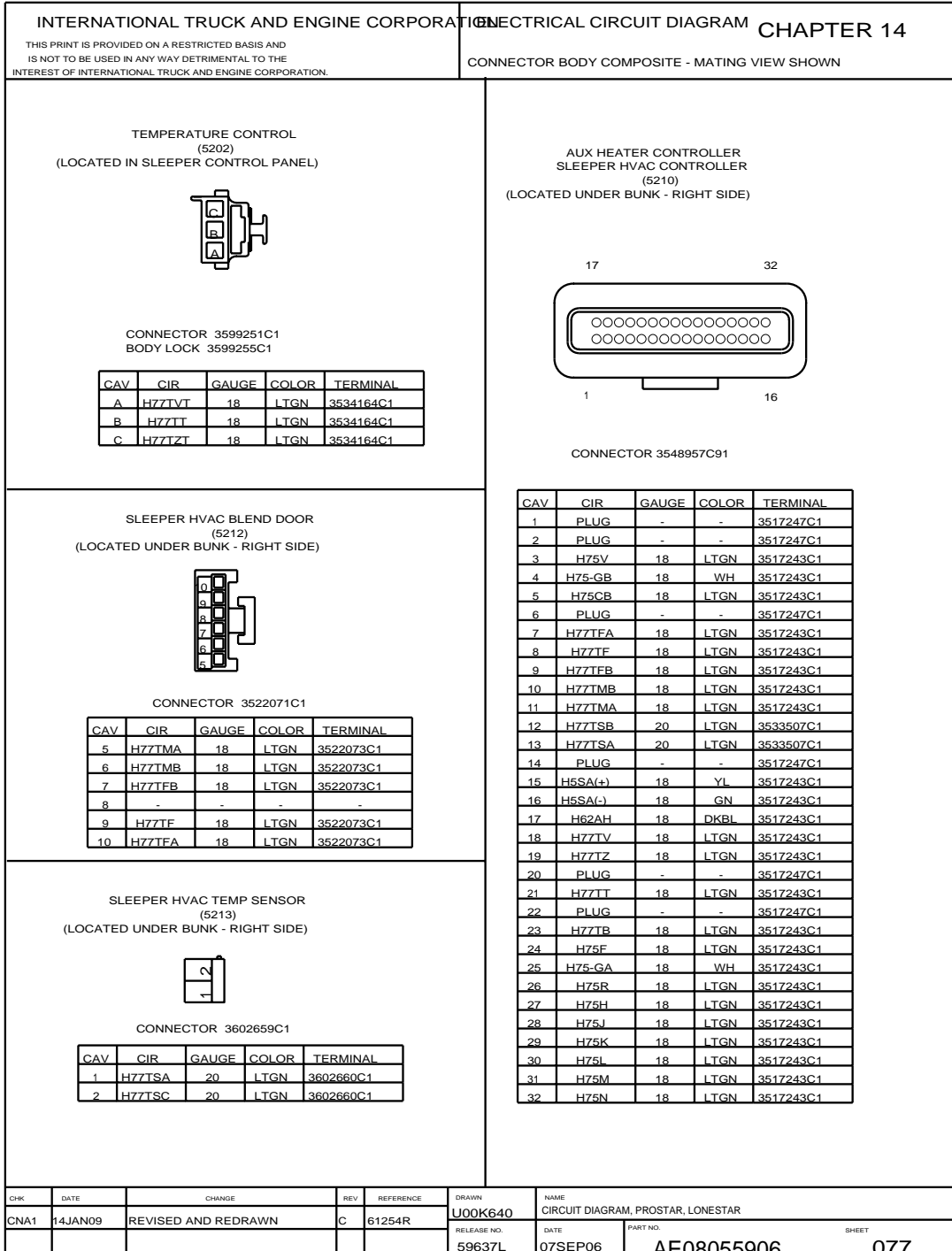


Figure 325 Connector Composites (5202), (5210), (5212), (5213)

14.97. CONNECTOR COMPOSITES (5214), (5215), (5216), (5217), (5218), (5219), P. 78

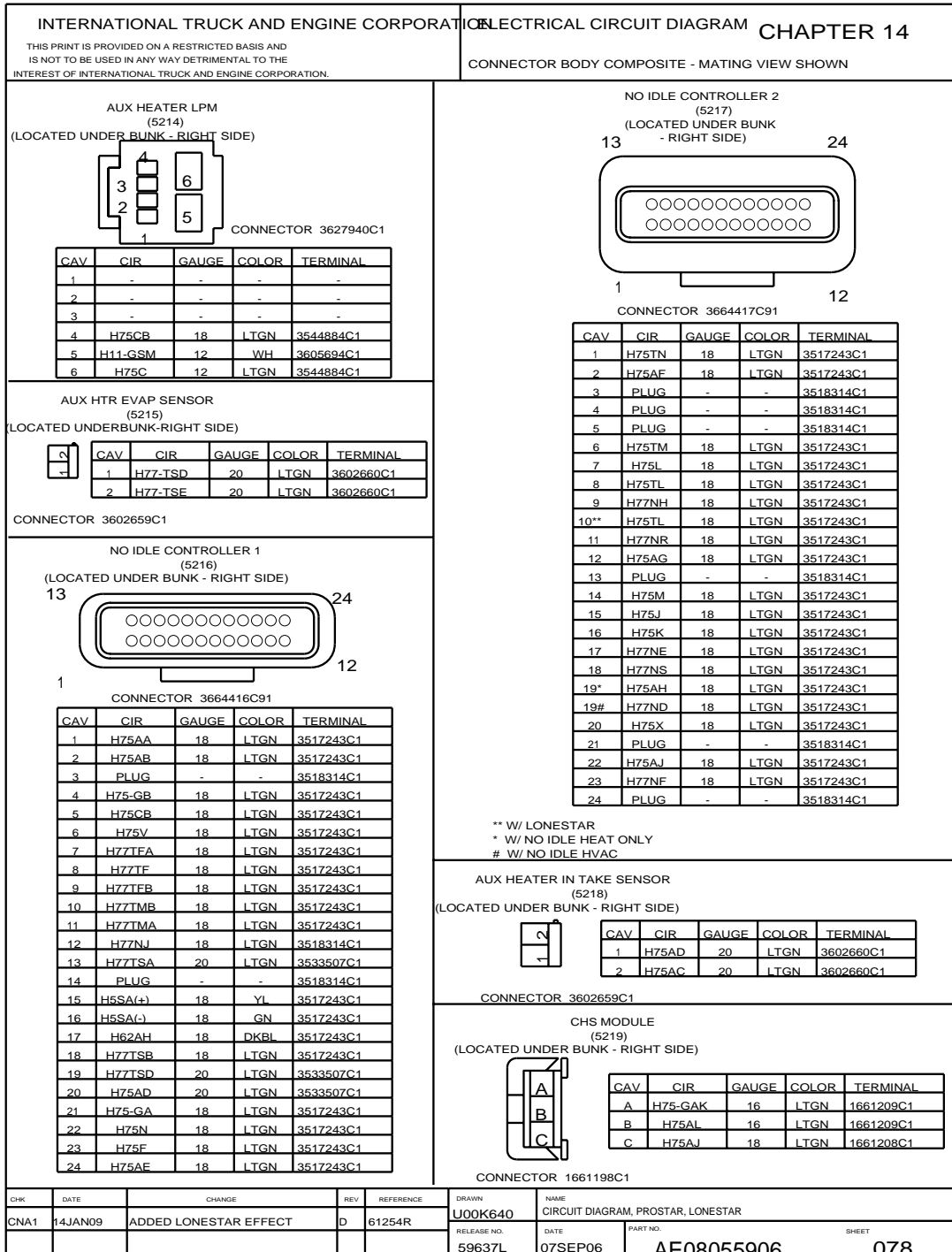


Figure 326 Connector Composites (5214), (5215), (5216), (5217), (5218), (5219)

14.98. CONNECTOR COMPOSITES (5220), (5222), (5230), P. 78A

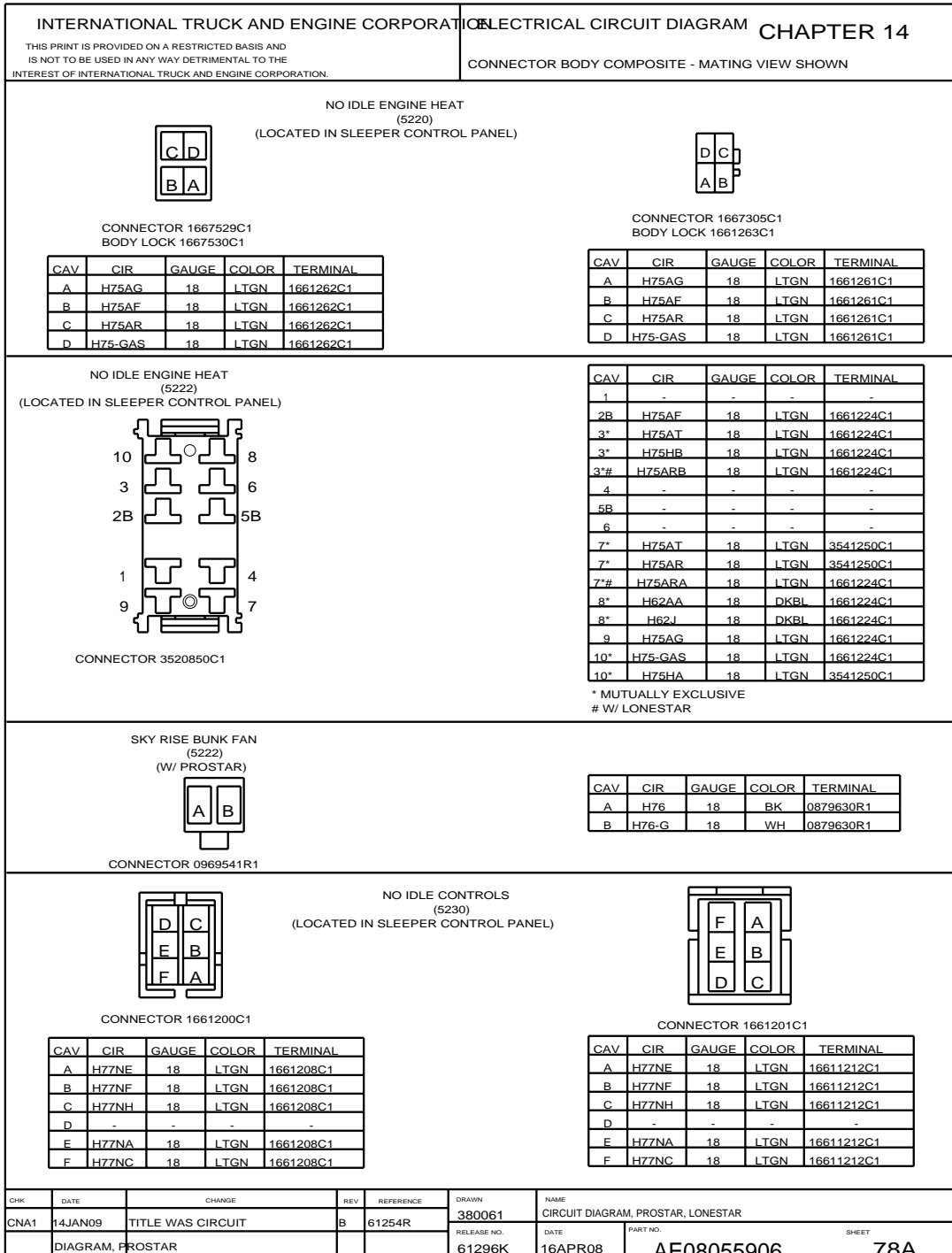


Figure 327 Connector Composites (5220), (5222), (5230)

14.99. CONNECTOR COMPOSITES (5232), (5233), (5234), P. 79

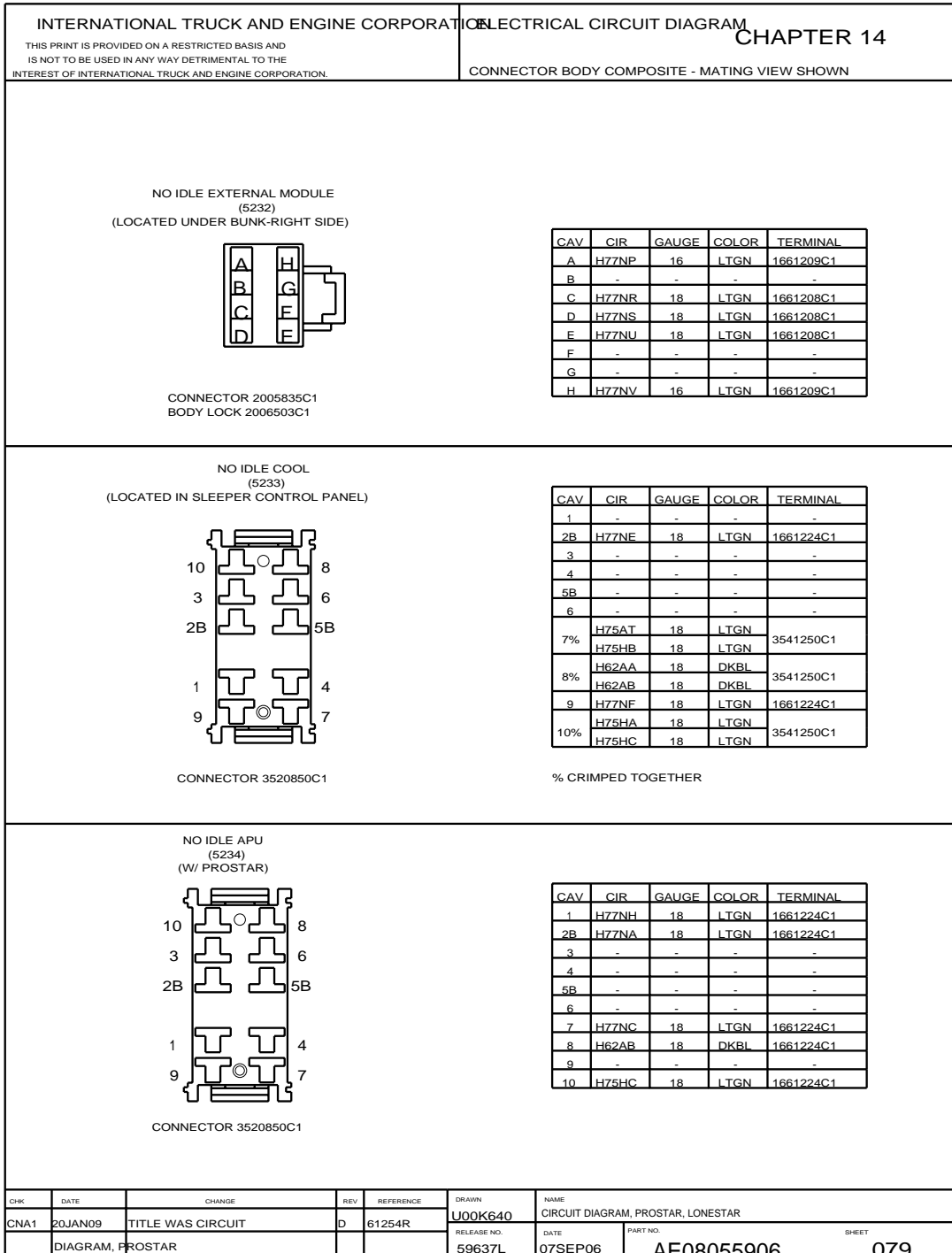


Figure 328 Connector Composites (5232), (5233), (5234)

14.100. CONNECTOR COMPOSITES (5300), (5301), (5302), (5303), P. 79A

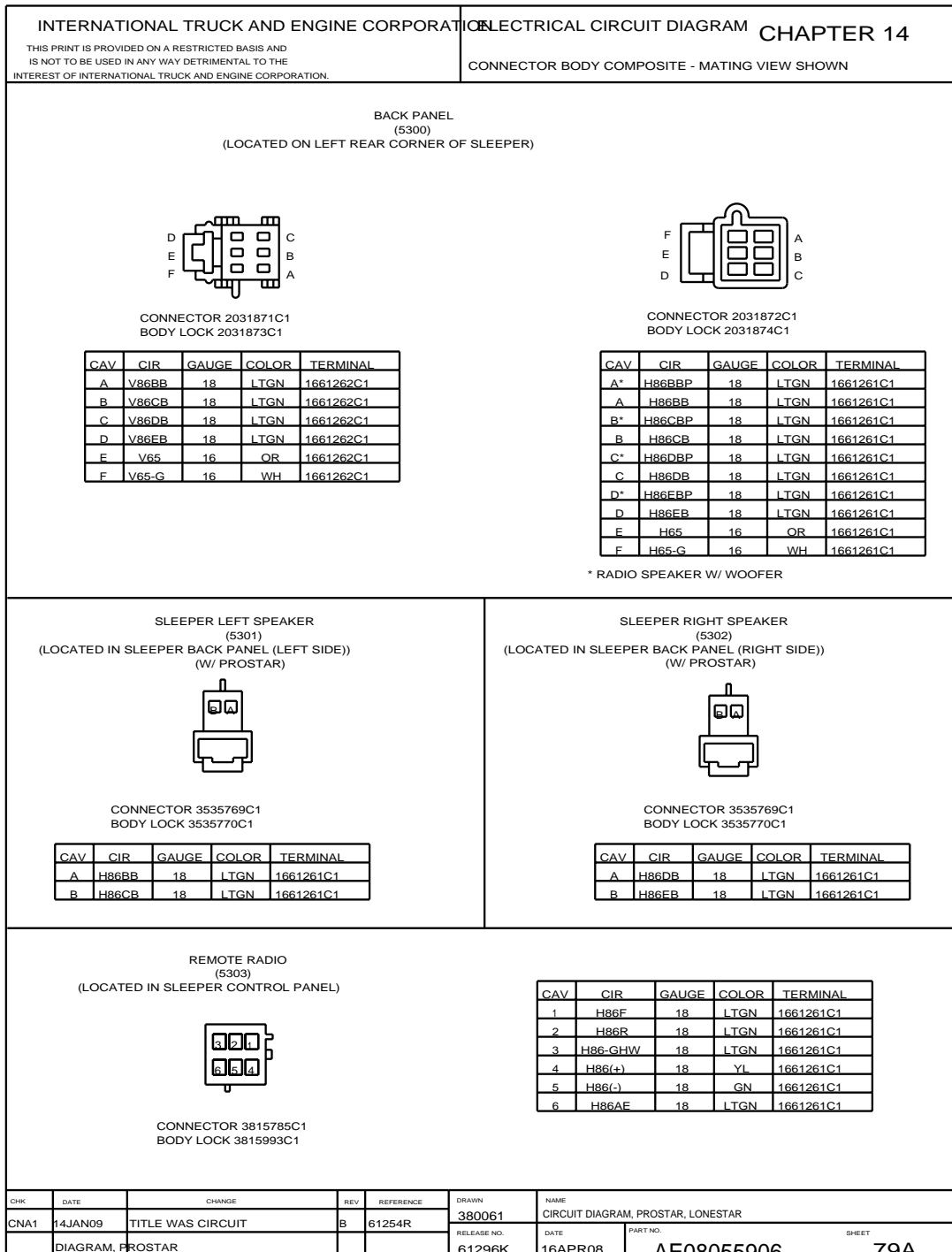


Figure 329 Connector Composites (5300), (5301), (5302), (5303)

14.101. CONNECTOR COMPOSITES (5312), (5313), (5314), (5500), (5502), (5600), P. 80

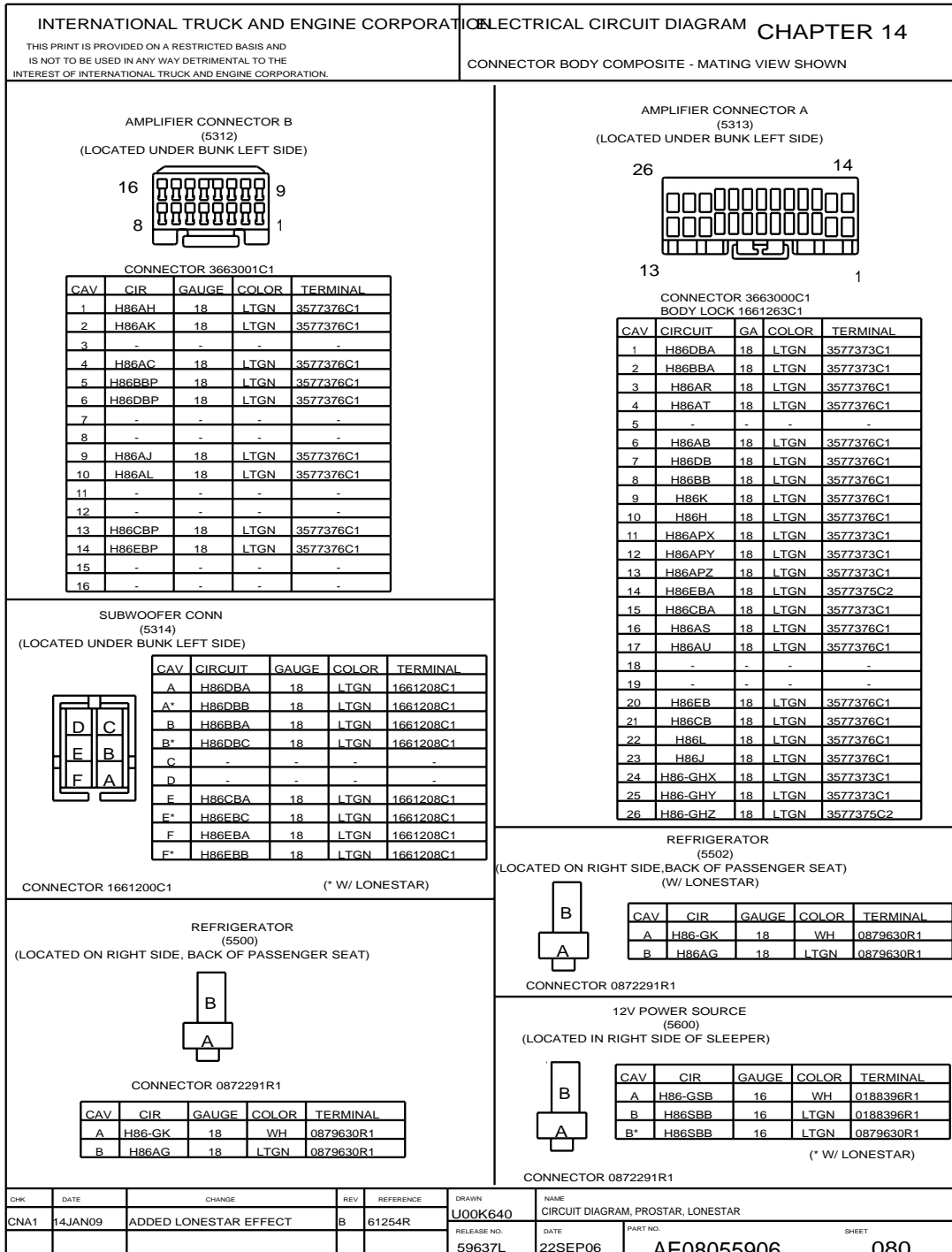


Figure 330 Connector Composites (5312), (5313), (5314), (5500), (5502), (5600)

14.102. CONNECTOR COMPOSITES (5601M), (5602F), (5602M), (5603M), (5700), P. 80A

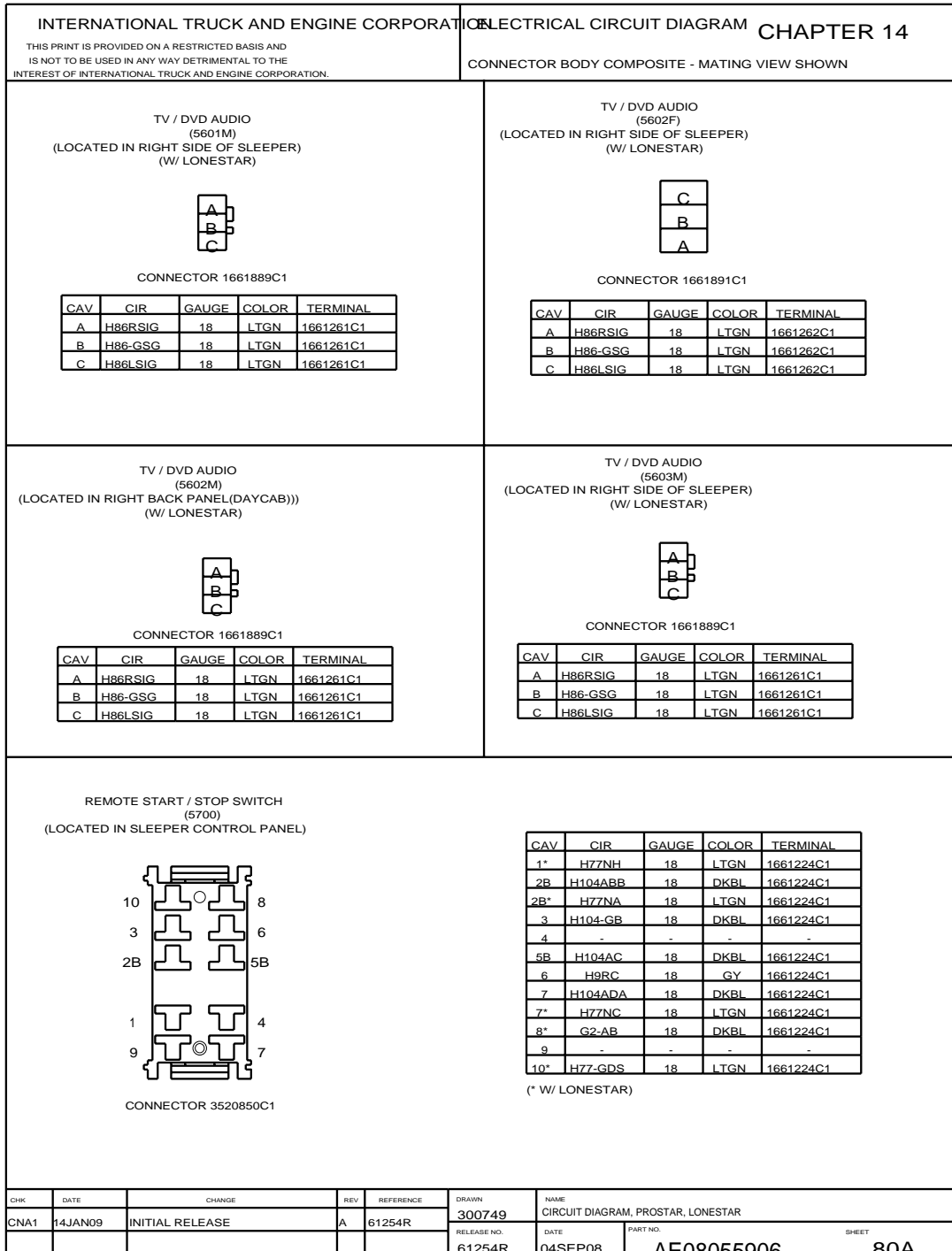


Figure 331 Connector Composites (5601M), (5602F), (5602M), (5603M), (5700)

14.103. CONNECTOR COMPOSITES (5701), (5702), (5752), (5753), (5754), P. 81

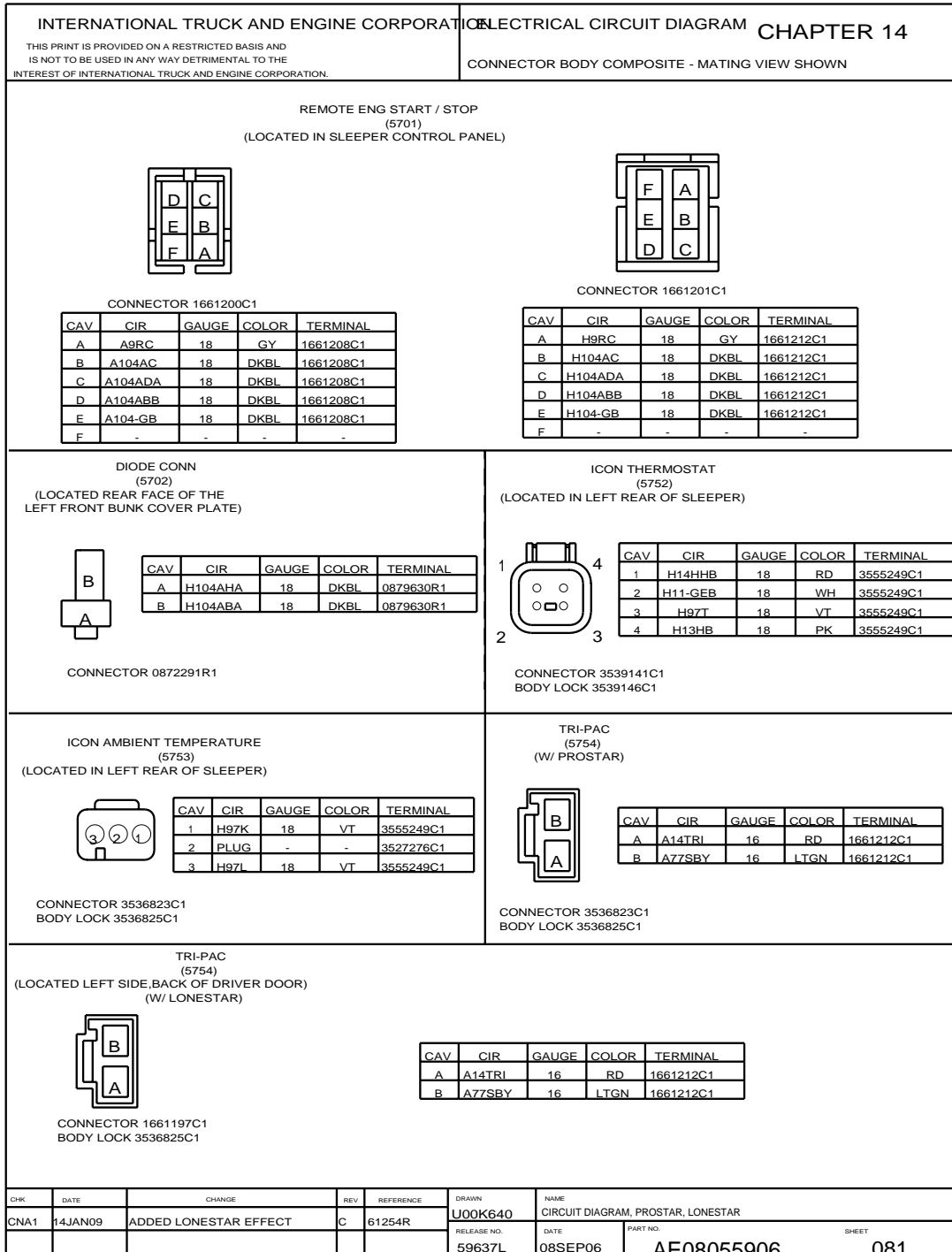


Figure 332 Connector Composites (5701), (5702), (5752), (5753), (5754)

14.104. CONNECTOR COMPOSITES (5757), (5758), (5803), (5900), (5902), (5903), P. 82

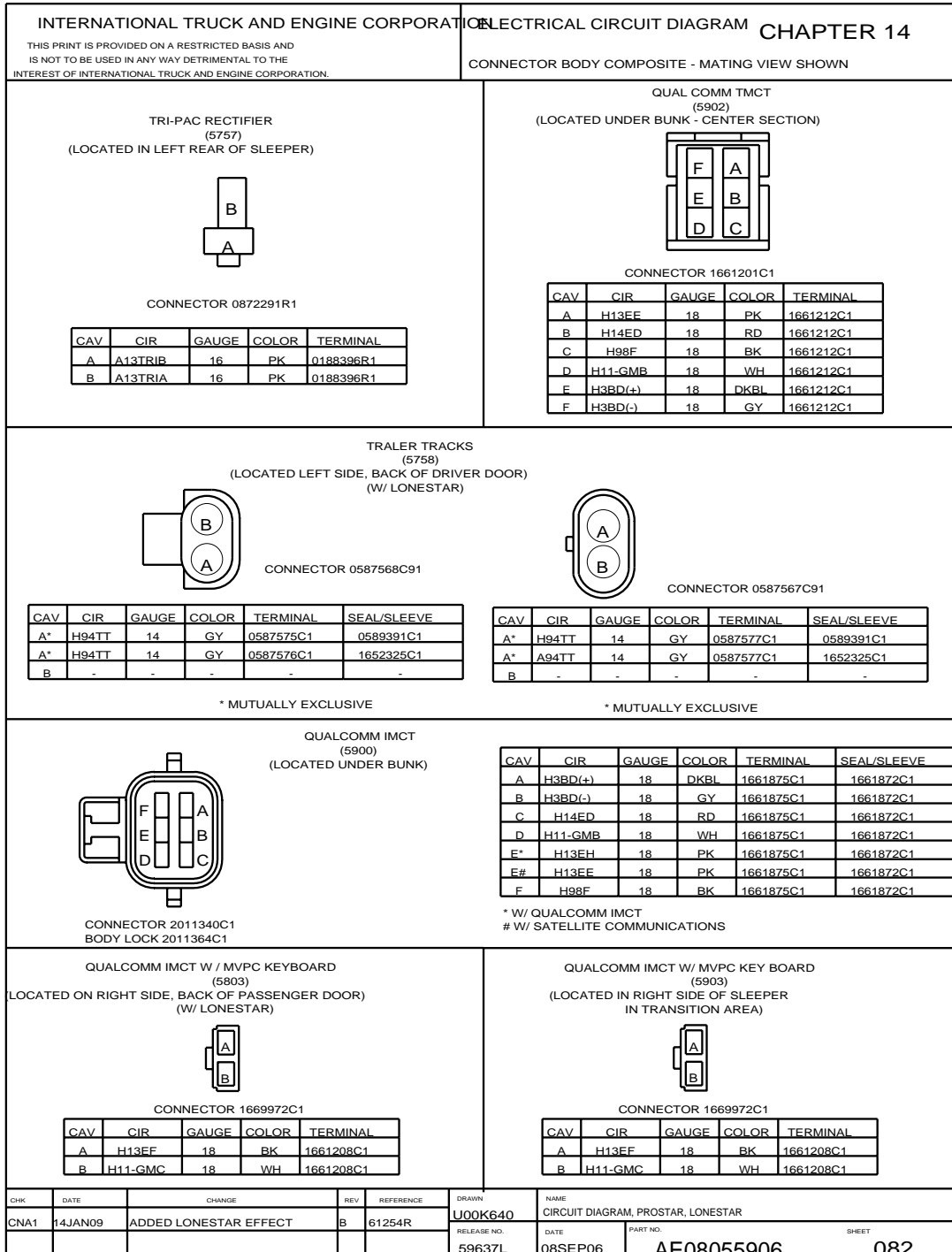


Figure 333 Connector Composites (5757), (5758), (5803), (5900), (5902), (5903)

14.105. CONNECTOR COMPOSITES (5904/5904M), (5905/5905F), P. 83

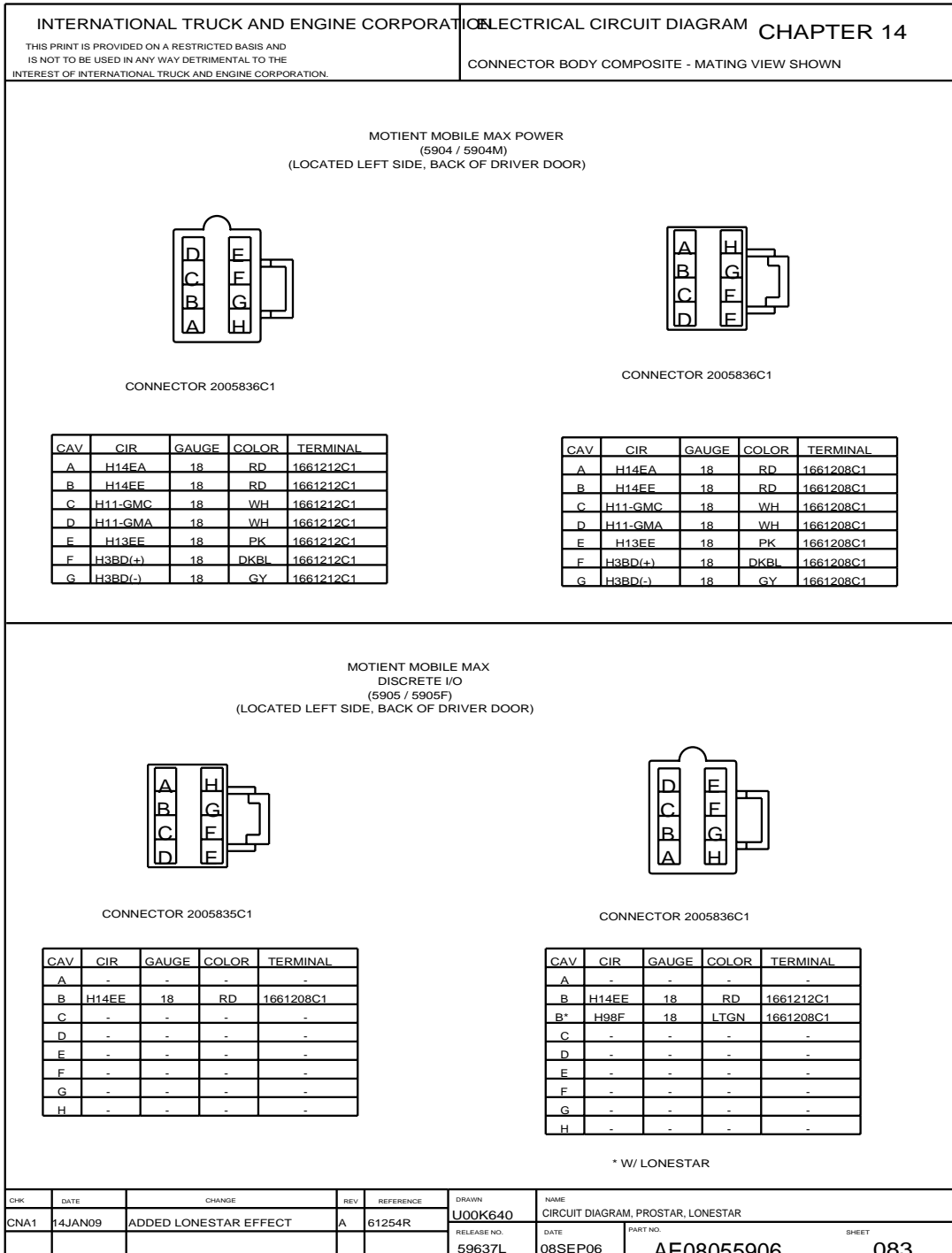


Figure 334 Connector Composites (5904/5904M), (5905/5905F)

14.106. CONNECTOR COMPOSITES (5906), (5907), P. 83A

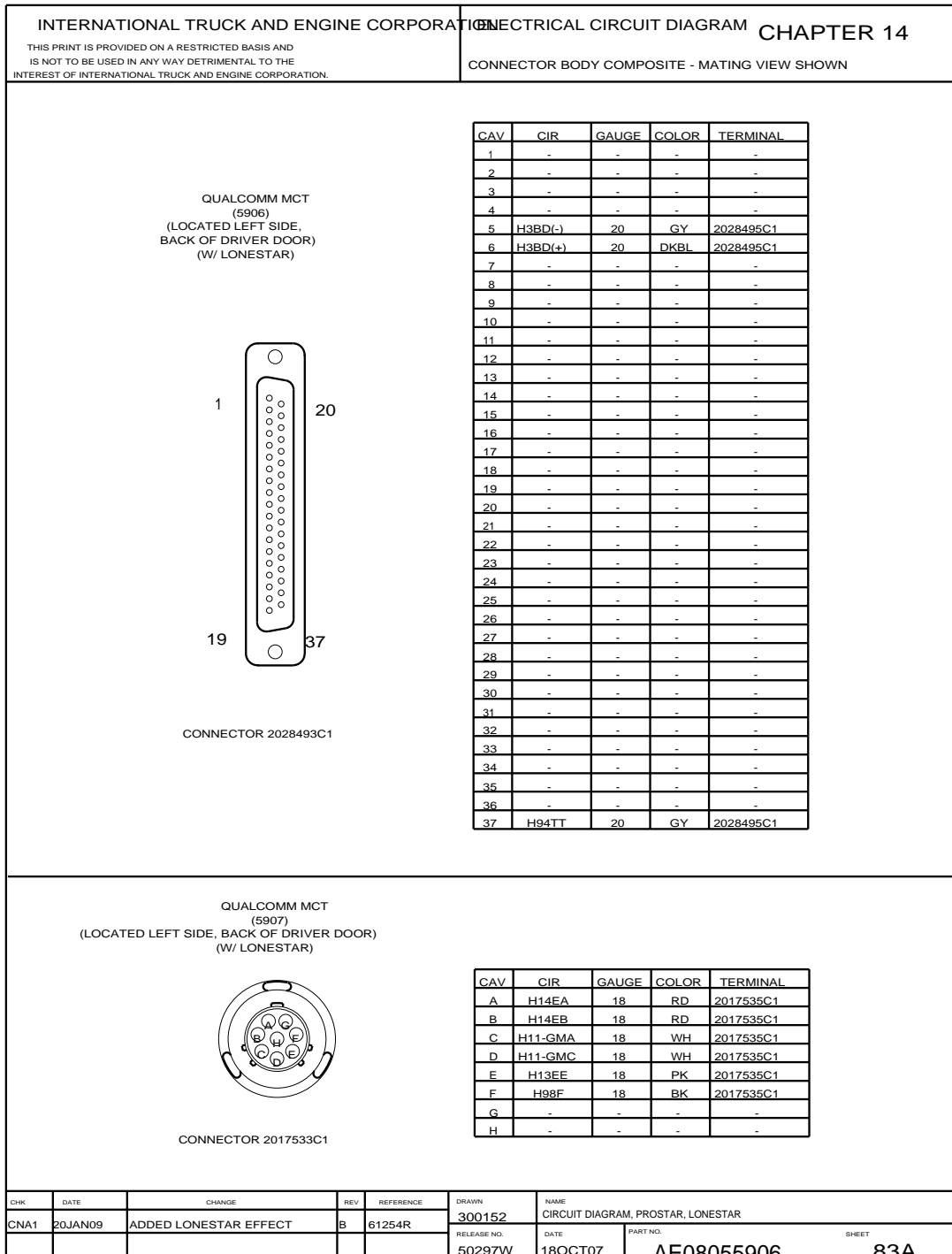


Figure 335 Connector Composites (5906), (5907)

14.107. CONNECTOR COMPOSITES (5909), (5925/5926), (5927), (5930M), (5940), P. 83B

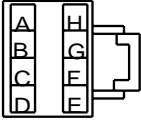

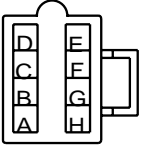
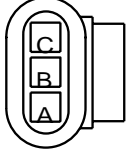

INTERNATIONAL TRUCK AND ENGINE CORPORATION <small>THIS PRINT IS PROVIDED ON A RESTRICTED BASIS AND IS NOT TO BE USED IN ANY WAY DETRIMENTAL TO THE INTEREST OF INTERNATIONAL TRUCK AND ENGINE CORPORATION.</small>		ELECTRICAL CIRCUIT DIAGRAM CHAPTER 14 CONNECTOR BODY COMPOSITE - MATING VIEW SHOWN																																																																																																
DRIVER TECH (5909) (LOCATED UNDER BUNK) (W/ LONESTAR)																																																																																																		
		<table border="1" style="width:100%; border-collapse: collapse;"> <thead> <tr> <th>CAV</th> <th>CIR</th> <th>GAUGE</th> <th>COLOR</th> <th>TERMINAL</th> </tr> </thead> <tbody> <tr><td>A</td><td>H14ED</td><td>18</td><td>RD</td><td>1661208C1</td></tr> <tr><td>C</td><td>H11-GMB</td><td>18</td><td>WH</td><td>1661208C1</td></tr> <tr><td>E</td><td>H13EE</td><td>18</td><td>PK</td><td>1661208C1</td></tr> <tr><td>F</td><td>H3BD(+)</td><td>18</td><td>DKBL</td><td>1661208C1</td></tr> <tr><td>G</td><td>H3BD(-)</td><td>18</td><td>GY</td><td>1661208C1</td></tr> </tbody> </table>		CAV	CIR	GAUGE	COLOR	TERMINAL	A	H14ED	18	RD	1661208C1	C	H11-GMB	18	WH	1661208C1	E	H13EE	18	PK	1661208C1	F	H3BD(+)	18	DKBL	1661208C1	G	H3BD(-)	18	GY	1661208C1																																																																	
CAV	CIR	GAUGE	COLOR	TERMINAL																																																																																														
A	H14ED	18	RD	1661208C1																																																																																														
C	H11-GMB	18	WH	1661208C1																																																																																														
E	H13EE	18	PK	1661208C1																																																																																														
F	H3BD(+)	18	DKBL	1661208C1																																																																																														
G	H3BD(-)	18	GY	1661208C1																																																																																														
CONNECTOR 2005835C1																																																																																																		
INVERTER CONTROLLER (5925 / 5926) (LOCATED ON LEFT SIDE, WALL OF SLEEPER) (W/ LONESTAR)		TRIP MASTER (5927) (LOCATED UNDER BUNK - CENTER SECTION)																																																																																																
																																																																																																		
CONNECTOR 3822477C91		CONNECTOR 2005836C1 BODY LOCK 2006504C1																																																																																																
<table border="1" style="width:100%; border-collapse: collapse;"> <thead> <tr> <th>CAV</th> <th>CIR</th> <th>GAUGE</th> <th>COLOR</th> <th>TERMINAL</th> </tr> </thead> <tbody> <tr><td>1</td><td>HX0</td><td>8</td><td>BK</td><td>ASSY</td></tr> <tr><td>1</td><td>HX1</td><td>24</td><td>-</td><td>ASSY</td></tr> <tr><td>2</td><td>HX2</td><td>24</td><td>-</td><td>ASSY</td></tr> <tr><td>3</td><td>HX3</td><td>24</td><td>-</td><td>ASSY</td></tr> <tr><td>4</td><td>HX4</td><td>24</td><td>-</td><td>ASSY</td></tr> <tr><td>5</td><td>HX5</td><td>24</td><td>-</td><td>ASSY</td></tr> <tr><td>6</td><td>HX6</td><td>24</td><td>-</td><td>ASSY</td></tr> <tr><td>7</td><td>HX7</td><td>24</td><td>-</td><td>ASSY</td></tr> <tr><td>8</td><td>HX8</td><td>24</td><td>-</td><td>ASSY</td></tr> </tbody> </table>		CAV	CIR	GAUGE	COLOR	TERMINAL	1	HX0	8	BK	ASSY	1	HX1	24	-	ASSY	2	HX2	24	-	ASSY	3	HX3	24	-	ASSY	4	HX4	24	-	ASSY	5	HX5	24	-	ASSY	6	HX6	24	-	ASSY	7	HX7	24	-	ASSY	8	HX8	24	-	ASSY	<table border="1" style="width:100%; border-collapse: collapse;"> <thead> <tr> <th>CAV</th> <th>CIR</th> <th>GAUGE</th> <th>COLOR</th> <th>TERMINAL</th> </tr> </thead> <tbody> <tr><td>A</td><td>H98A</td><td>18</td><td>BK</td><td>1661212C1</td></tr> <tr><td>B</td><td>H88B</td><td>18</td><td>BK</td><td>1661212C1</td></tr> <tr><td>C</td><td>H13SD</td><td>18</td><td>PK</td><td>1661212C1</td></tr> <tr><td>D</td><td>H11-GSD</td><td>18</td><td>WH</td><td>1661212C1</td></tr> <tr><td>E</td><td>H14SD</td><td>18</td><td>RD</td><td>1661212C1</td></tr> <tr><td>F</td><td>H50S</td><td>18</td><td>YL</td><td>1661212C1</td></tr> <tr><td>G</td><td>H70E</td><td>18</td><td>OR</td><td>1661212C1</td></tr> <tr><td>H</td><td>-</td><td>-</td><td>-</td><td>-</td></tr> </tbody> </table>		CAV	CIR	GAUGE	COLOR	TERMINAL	A	H98A	18	BK	1661212C1	B	H88B	18	BK	1661212C1	C	H13SD	18	PK	1661212C1	D	H11-GSD	18	WH	1661212C1	E	H14SD	18	RD	1661212C1	F	H50S	18	YL	1661212C1	G	H70E	18	OR	1661212C1	H	-	-	-	-
CAV	CIR	GAUGE	COLOR	TERMINAL																																																																																														
1	HX0	8	BK	ASSY																																																																																														
1	HX1	24	-	ASSY																																																																																														
2	HX2	24	-	ASSY																																																																																														
3	HX3	24	-	ASSY																																																																																														
4	HX4	24	-	ASSY																																																																																														
5	HX5	24	-	ASSY																																																																																														
6	HX6	24	-	ASSY																																																																																														
7	HX7	24	-	ASSY																																																																																														
8	HX8	24	-	ASSY																																																																																														
CAV	CIR	GAUGE	COLOR	TERMINAL																																																																																														
A	H98A	18	BK	1661212C1																																																																																														
B	H88B	18	BK	1661212C1																																																																																														
C	H13SD	18	PK	1661212C1																																																																																														
D	H11-GSD	18	WH	1661212C1																																																																																														
E	H14SD	18	RD	1661212C1																																																																																														
F	H50S	18	YL	1661212C1																																																																																														
G	H70E	18	OR	1661212C1																																																																																														
H	-	-	-	-																																																																																														
J1939 (5930M) (LOCATED UNDER BUNK - RIGHT SIDE)		XATA MODULE (5940) (LOCATED UNDER BUNK - CENTER SECTION)																																																																																																
																																																																																																		
CONNECTOR 1667741C1		CONNECTOR 1667305C1 BODY LOCK 1661263C1																																																																																																
<table border="1" style="width:100%; border-collapse: collapse;"> <thead> <tr> <th>CAV</th> <th>CIR</th> <th>GAUGE</th> <th>COLOR</th> <th>TERMINAL</th> <th>SEAL/SLEEVE</th> </tr> </thead> <tbody> <tr><td>A</td><td>H5T(+)</td><td>18</td><td>YL</td><td>1661875C1</td><td>3568570C1</td></tr> <tr><td>B</td><td>PLUG</td><td>-</td><td>-</td><td>2025431C1</td><td>-</td></tr> <tr><td>C</td><td>H5T(-)</td><td>18</td><td>GN</td><td>1661875C1</td><td>3568570C1</td></tr> </tbody> </table>		CAV	CIR	GAUGE	COLOR	TERMINAL	SEAL/SLEEVE	A	H5T(+)	18	YL	1661875C1	3568570C1	B	PLUG	-	-	2025431C1	-	C	H5T(-)	18	GN	1661875C1	3568570C1	<table border="1" style="width:100%; border-collapse: collapse;"> <thead> <tr> <th>CAV</th> <th>CIR</th> <th>GAUGE</th> <th>COLOR</th> <th>TERMINAL</th> </tr> </thead> <tbody> <tr><td>A</td><td>JE14EA</td><td>18</td><td>RD</td><td>1661261C1</td></tr> <tr><td>B</td><td>JE11-GMD</td><td>18</td><td>WH</td><td>1661261C1</td></tr> <tr><td>C</td><td>JE3BE(+)</td><td>18</td><td>DKBL</td><td>1661261C1</td></tr> <tr><td>D</td><td>JE3BE(-)</td><td>18</td><td>GY</td><td>1661261C1</td></tr> </tbody> </table>		CAV	CIR	GAUGE	COLOR	TERMINAL	A	JE14EA	18	RD	1661261C1	B	JE11-GMD	18	WH	1661261C1	C	JE3BE(+)	18	DKBL	1661261C1	D	JE3BE(-)	18	GY	1661261C1																																														
CAV	CIR	GAUGE	COLOR	TERMINAL	SEAL/SLEEVE																																																																																													
A	H5T(+)	18	YL	1661875C1	3568570C1																																																																																													
B	PLUG	-	-	2025431C1	-																																																																																													
C	H5T(-)	18	GN	1661875C1	3568570C1																																																																																													
CAV	CIR	GAUGE	COLOR	TERMINAL																																																																																														
A	JE14EA	18	RD	1661261C1																																																																																														
B	JE11-GMD	18	WH	1661261C1																																																																																														
C	JE3BE(+)	18	DKBL	1661261C1																																																																																														
D	JE3BE(-)	18	GY	1661261C1																																																																																														
CHK	DATE	CHANGE	REV	REFERENCE	DRAWN	NAME																																																																																												
CNA1	14JAN09	INITIAL RELEASE	A	61254R	300638	CIRCUIT DIAGRAM, PROSTAR, LONESTAR																																																																																												
					RELEASE NO.	DATE																																																																																												
					61254R	15SEP08																																																																																												
						PART NO.																																																																																												
						AE08055906																																																																																												
						SHEET																																																																																												
						83B																																																																																												

Figure 336 Connector Composites (5909), (5925/5926), (5927), (5930M), (5940)

14.108. CONNECTOR COMPOSITE (6000), P. 84

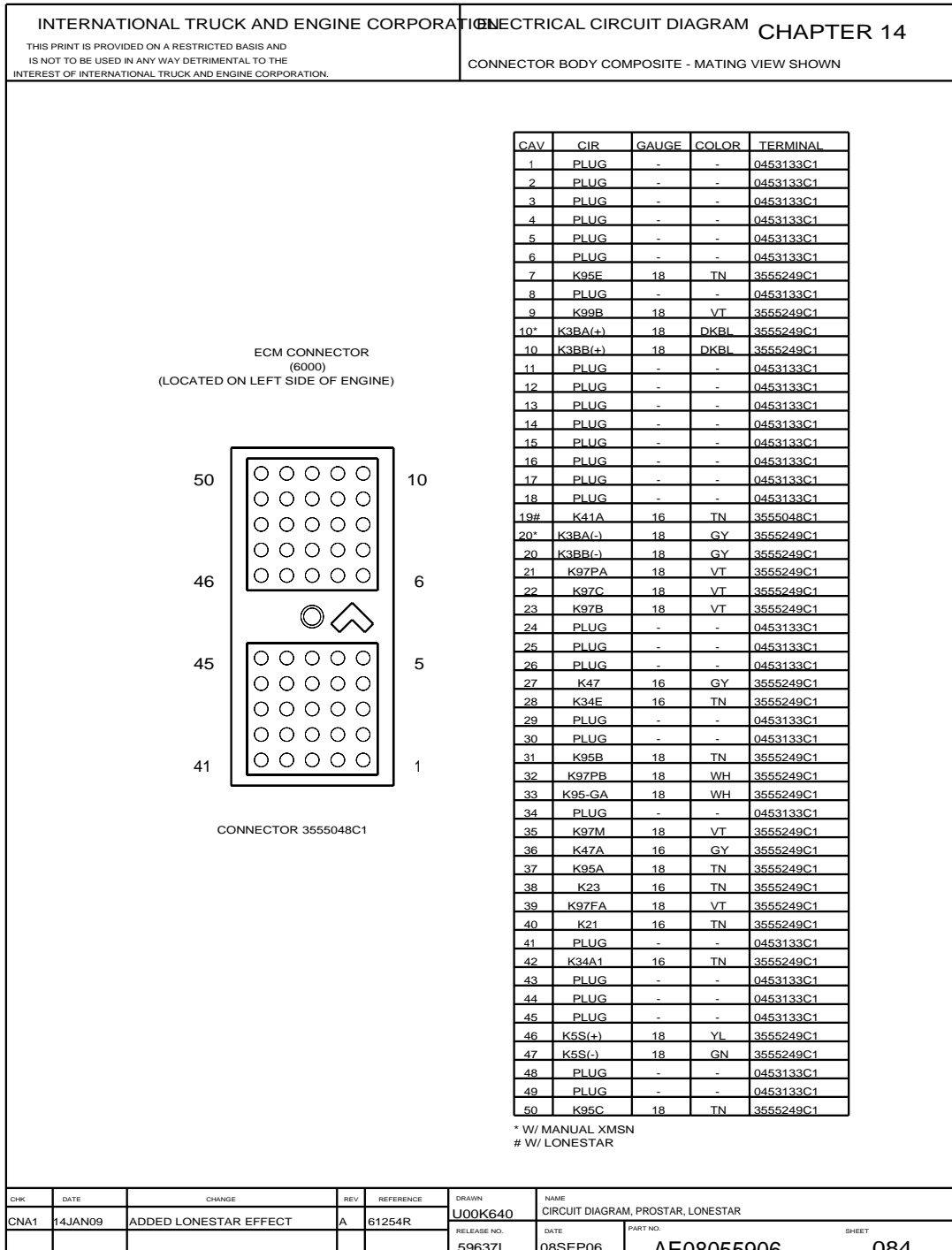


Figure 337 Connector Composite (6000)

14.109. CONNECTOR COMPOSITE (6010), P. 84A

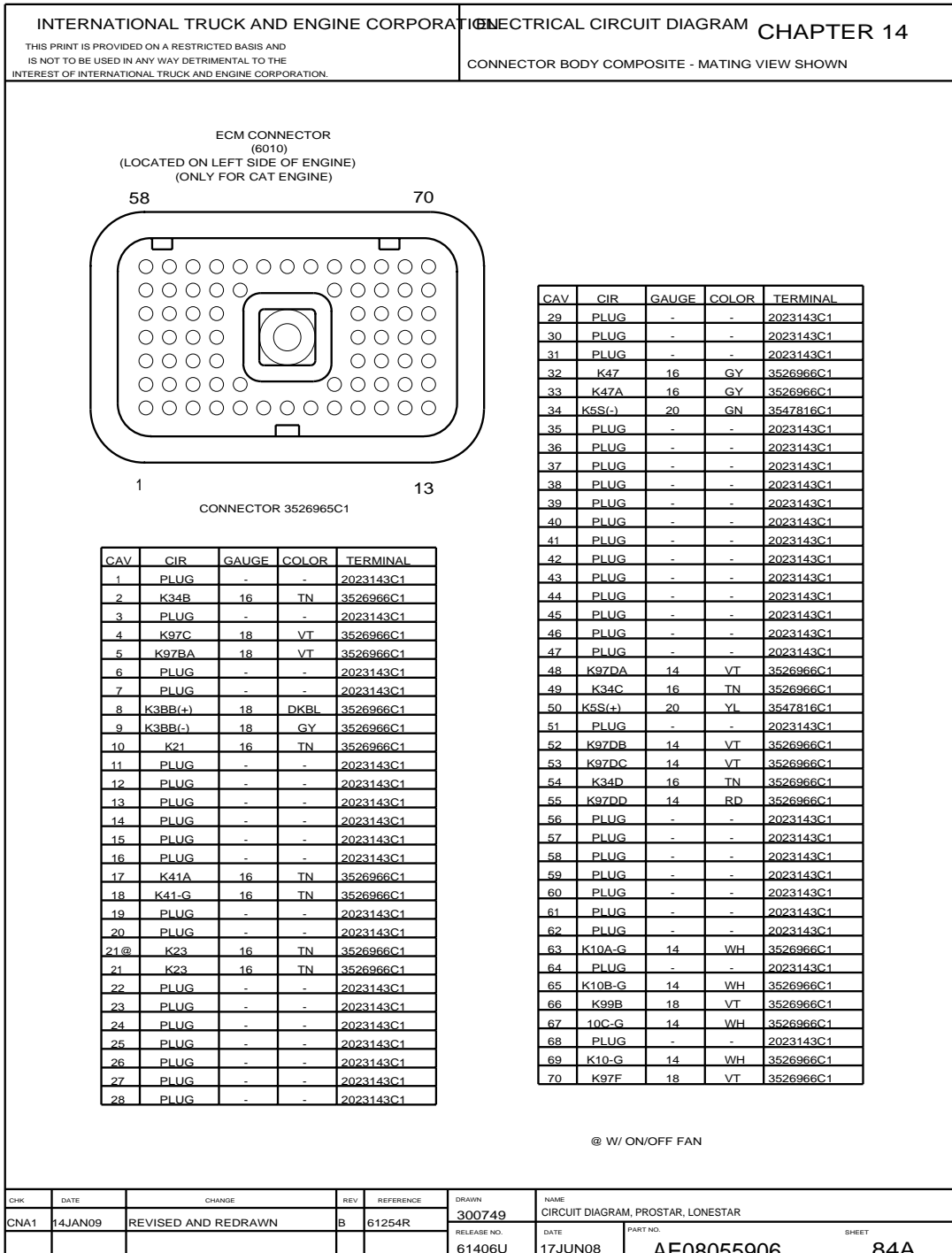


Figure 338 Connector Composite (6010)

14.110. CONNECTOR COMPOSITES (6001), (6018), (6019), P. 85

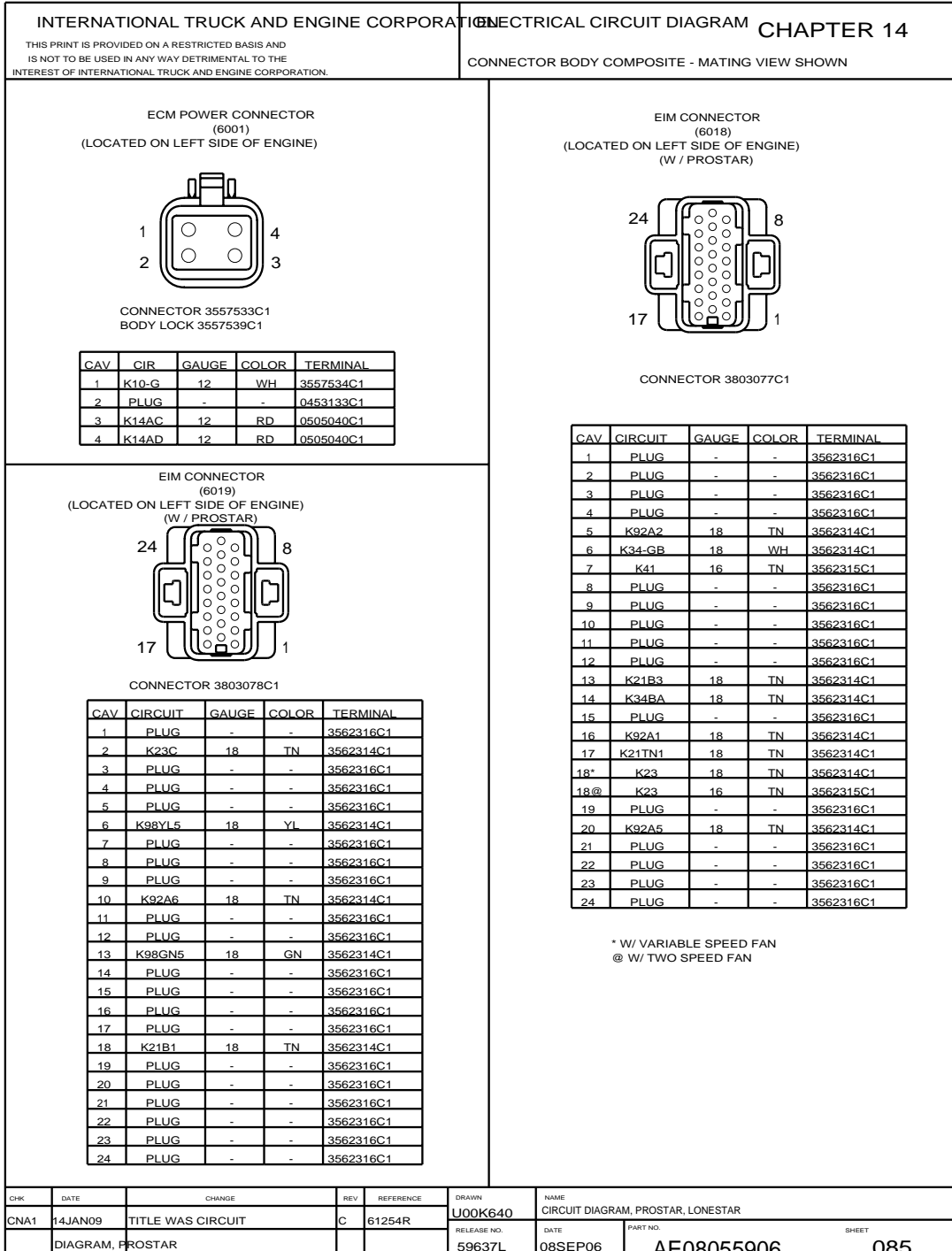


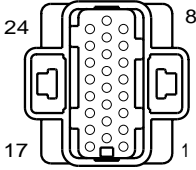
Figure 339 Connector Composites (6001), (6018), (6019)

14.111. CONNECTOR COMPOSITES (6020), (6021), (6033), P. 85A

INTERNATIONAL TRUCK AND ENGINE CORPORATION		ELECTRICAL CIRCUIT DIAGRAM		CHAPTER 14	
THIS PRINT IS PROVIDED ON A RESTRICTED BASIS AND IS NOT TO BE USED IN ANY WAY DETRIMENTAL TO THE INTEREST OF INTERNATIONAL TRUCK AND ENGINE CORPORATION.		CONNECTOR BODY COMPOSITE - MATING VIEW SHOWN			

EIM CONNECTOR (6020)  
(LOCATED ON LEFT SIDE OF ENGINE)  
(W/ PROSTAR)



CONNECTOR 3562311C1

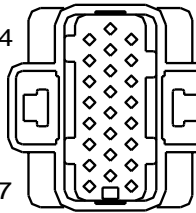
& MUTUALLY EXCLUSIVE

CAV	CIRCUIT	GAUGE	COLOR	TERMINAL
1	PLUG	-	-	3562316C1
2	K34C	18	TN	3562314C1
3	K97F	18	VT	3562314C1
4	K34D	18	TN	3562314C1
5	K97A1	18	VT	3562314C1
6	K92A16	16	WH	3562315C1
7	K92B16	16	WH	3562315C1
8	K97A2	18	VT	3562314C1
9	PLUG	-	-	3562316C1
10	PLUG	-	-	3562316C1
11	K92A8	18	TN	3562314C1
12	K6S(+)	18	YL	3562314C1

CAV	CIRCUIT	GAUGE	COLOR	TERMINAL
13	K5S(-)	18	GN	3562314C1
14	K92A9	18	TN	3562314C1
15	PLUG	-	-	3562316C1
16	PLUG	-	-	3562316C1
17&	K92A10	18	TN	3562314C1
17&	K47T	18	GY	3562314C1
18	PLUG	-	-	3562316C1
19	K92A11	18	TN	3562314C1
20	K92A12	18	TN	3562314C1
21	K92A13	18	TN	3562314C1
22	PLUG	-	-	3562316C1
23	PLUG	-	-	3562316C1
24	PLUG	-	-	3562316C1

EIM CONNECTOR 4 (6021)  
(LOCATED ON LEFT SIDE OF ENGINE)  
(W/ PROSTAR)



CONNECTOR 3562312C1

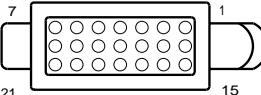
\* W/ MANUAL XMSN  
# W/ MERITOR G XMSN  
% W/ AUTOSHIFT & ULTRASHIFT XMSN

CAV	CIRCUIT	GAUGE	COLOR	TERMINAL
1	K14G	16	RD	3562315C1
2	K14H	16	RD	3562315C1
3	PLUG	-	-	3562316C1
4	K97CB	18	VT	3562314C1
5	PLUG	-	-	3562316C1
6	K92A7	18	TN	3562314C1
7	PLUG	-	-	3562316C1
8	PLUG	-	-	3562316C1
9#	K47A	16	GY	3562315C1
9*	K47A	18	GY	3562314C1
9*	K47E	18	GY	3562314C1
10#	K47	16	GY	3562315C1
10*	K47D	18	GY	3562314C1
10*	K47	18	GY	3562314C1
11	PLUG	-	-	3562316C1

CAV	CIRCUIT	GAUGE	COLOR	TERMINAL
12	PLUG	-	-	3562316C1
13	PLUG	-	-	3562316C1
14	K21B2	18	TN	3562314C1
15	PLUG	-	-	3562316C1
16	PLUG	-	-	3562316C1
17	K92A14	18	TN	3562314C1
18	K99B	18	VT	3562314C1
19	PLUG	-	-	3562316C1
20%	K3BB(+)	18	DKBL	3562314C1
20*#	K3BA(+)	18	DKBL	3562314C1
21%	K3BB(-)	18	GY	3562314C1
21*#	K3BA(-)	18	GY	3562314C1
22	PLUG	-	-	3562316C1
23	K97NA	18	VT	3562314C1
24	K97B	18	VT	3562314C1

ENGINE SENSOR INTERFACE (6033)  
(LOCATED ON LEFT SIDE OF ENGINE)  
(W/ PROSTAR)



CONNECTOR 3803137C1  
BODY LOCK 3803139C1  
3803117C1

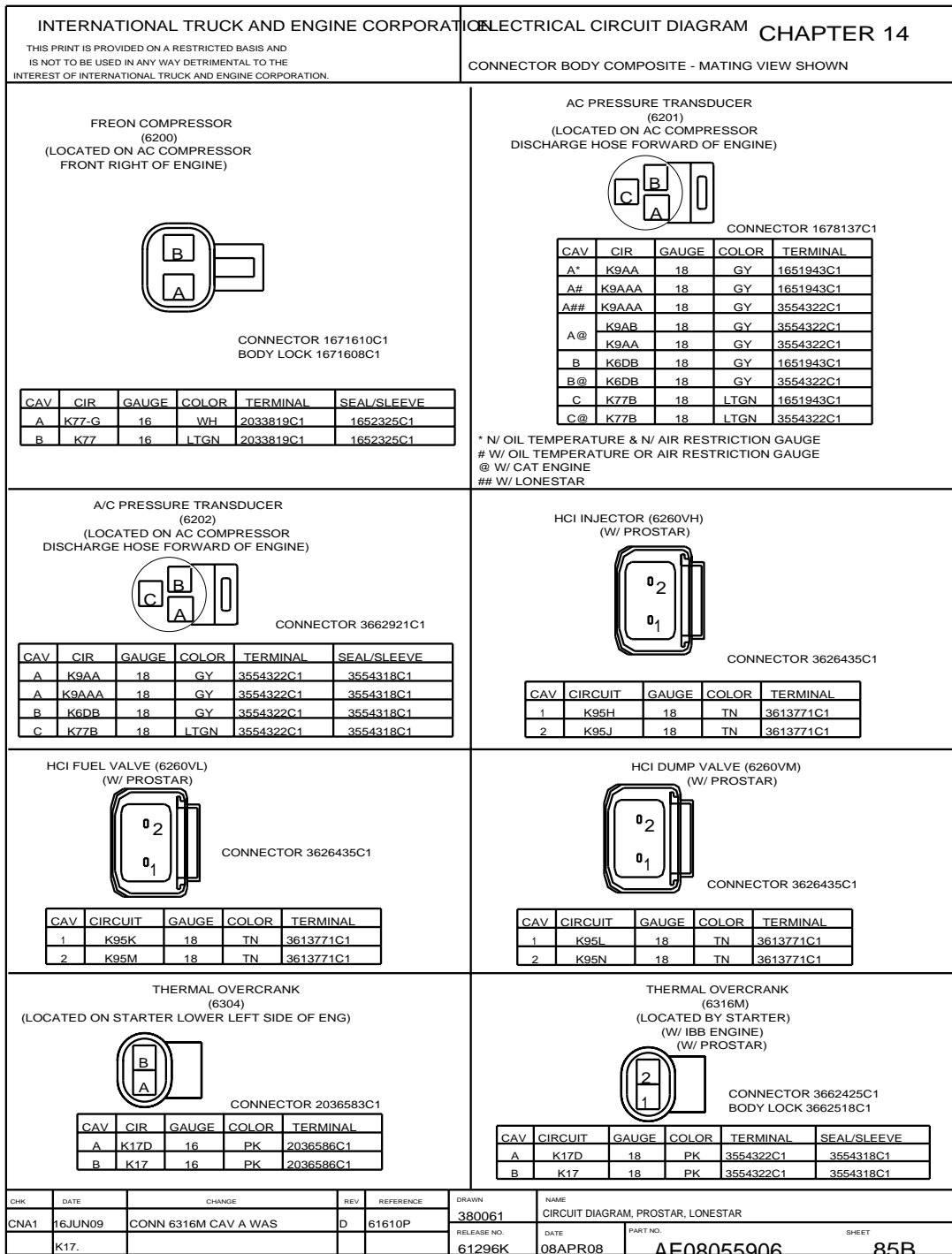
CAV	CIRCUIT	GAUGE	COLOR	TERMINAL	SEAL/SLEEVE
10	K98Y1	18	YL	3803140C1	3803134C1
11	PLUG	-	-	3803138C1	-
12	PLUG	-	-	3803138C1	-
13	K91A	18	VT	3803140C1	3803134C1
14	PLUG	-	-	3803138C1	-
15	K14A	16	RD	3803140C1	3803134C1
16	K14B	16	RD	3803140C1	3803134C1
17	K14C	16	RD	3803140C1	3803134C1
18	K14D	16	RD	3803140C1	3803134C1
19	PLUG	-	-	3803138C1	-
20	PLUG	-	-	3803138C1	-
21	K14F	18	RD	3803140C1	3803134C1

CHK	DATE	CHANGE	REV	REFERENCE	DRAWN	NAME
CNA1	16JUN09	REVISED AND REDRAWN.	D	61610P	300152	CIRCUIT DIAGRAM, PROSTAR, LONESTAR
					RELEASE NO. 50297W	DATE 18OCT07
						PART NO. AE08055906
						SHEET 85A

Figure 340 Connector Composites (6020), (6021), (6033)

**14.112. CONNECTOR COMPOSITES (6200), (6201), (6202), (6260VH), (6260VL), (6260VM), (6304), (6316M), P. 85B**



**Figure 341 Connector Composites (6200), (6201), (6202), (6260VH), (6260VL), (6260VM), (6304), (6316M)**

14.113. CONNECTOR COMPOSITES (6400), (6401), (6402), (6403), (6406/6402), P. 86

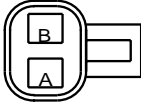
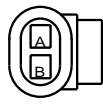
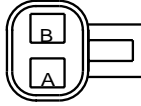
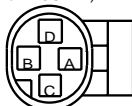
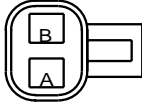
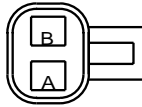
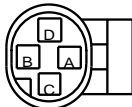
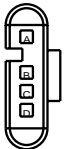
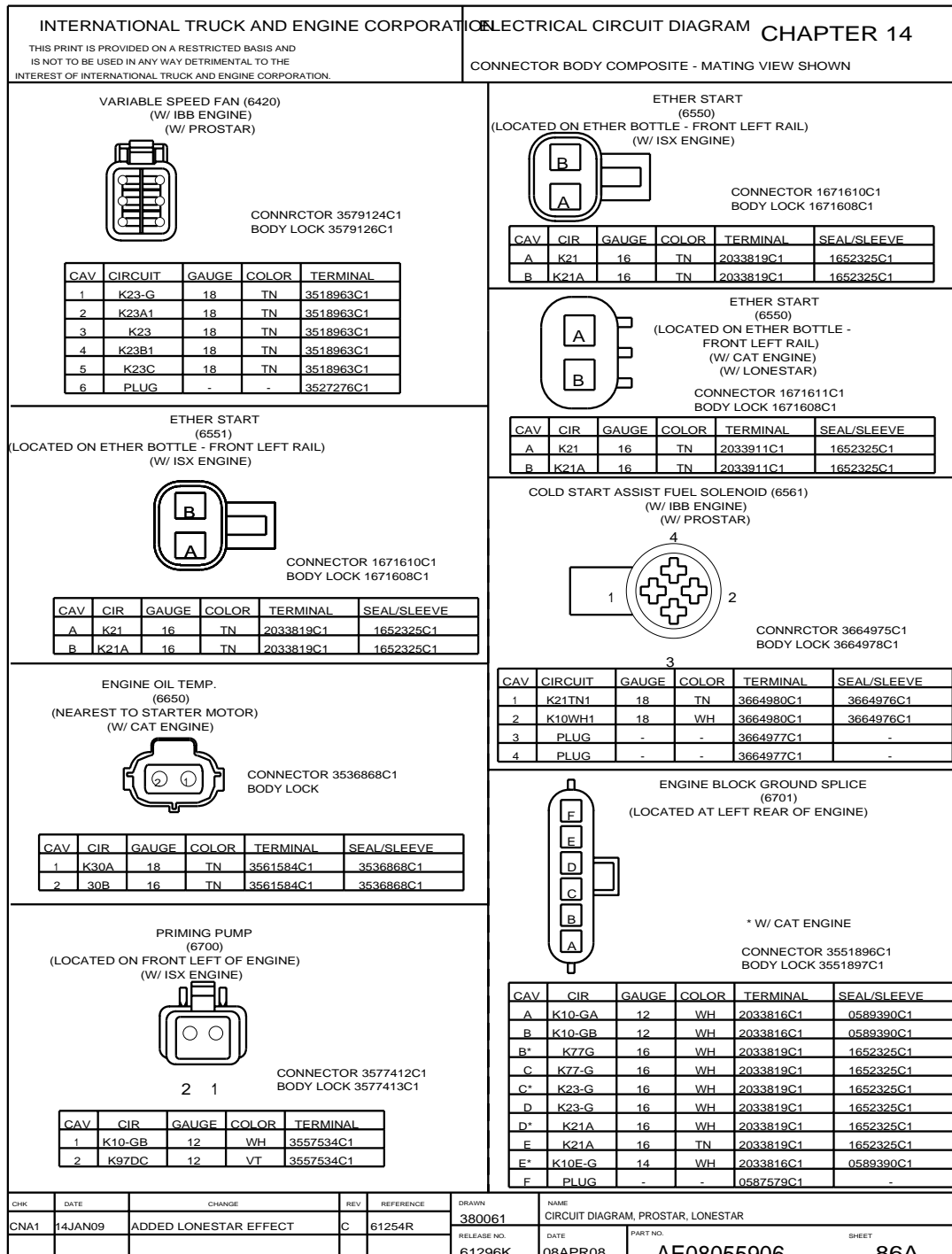
INTERNATIONAL TRUCK AND ENGINE CORPORATION		ELECTRICAL CIRCUIT DIAGRAM CHAPTER 14																																																															
THIS PRINT IS PROVIDED ON A RESTRICTED BASIS AND IS NOT TO BE USED IN ANY WAY DETRIMENTAL TO THE INTEREST OF INTERNATIONAL TRUCK AND ENGINE CORPORATION.		CONNECTOR BODY COMPOSITE - MATING VIEW SHOWN																																																															
<p>FAN SOLENOID (6400) (LOCATED ON LEFT REAR OF ENGINE)</p>  <p>CONNECTOR 1671610C1 BODY LOCK 1671608C1</p> <table border="1" style="width:100%; border-collapse: collapse; font-size: x-small;"> <thead> <tr> <th>CAV</th> <th>CIR</th> <th>GAUGE</th> <th>COLOR</th> <th>TERMINAL</th> <th>SEAL/SLEEVE</th> </tr> </thead> <tbody> <tr> <td>A</td> <td>K23</td> <td>16</td> <td>TN</td> <td>2033819C1</td> <td>1652325C1</td> </tr> <tr> <td>B</td> <td>K23-G</td> <td>16</td> <td>WH</td> <td>2033819C1</td> <td>1652325C1</td> </tr> </tbody> </table>		CAV	CIR	GAUGE	COLOR	TERMINAL	SEAL/SLEEVE	A	K23	16	TN	2033819C1	1652325C1	B	K23-G	16	WH	2033819C1	1652325C1	<p>FAN SOLENOID (6400) (W/ IBB ENGINE) (W/ PROSTAR)</p>  <p>CONNECTOR 3522068C1 BODY LOCK 1661874C1</p> <table border="1" style="width:100%; border-collapse: collapse; font-size: x-small;"> <thead> <tr> <th>CAV</th> <th>CIRCUIT</th> <th>GAUGE</th> <th>COLOR</th> <th>TERMINAL</th> <th>SEAL/SLEEVE</th> </tr> </thead> <tbody> <tr> <td>A</td> <td>K23</td> <td>16</td> <td>TN</td> <td>1661875C1</td> <td>1661872C1</td> </tr> <tr> <td>B</td> <td>K23-G</td> <td>16</td> <td>WH</td> <td>1661875C1</td> <td>1661872C1</td> </tr> </tbody> </table>				CAV	CIRCUIT	GAUGE	COLOR	TERMINAL	SEAL/SLEEVE	A	K23	16	TN	1661875C1	1661872C1	B	K23-G	16	WH	1661875C1	1661872C1																								
CAV	CIR	GAUGE	COLOR	TERMINAL	SEAL/SLEEVE																																																												
A	K23	16	TN	2033819C1	1652325C1																																																												
B	K23-G	16	WH	2033819C1	1652325C1																																																												
CAV	CIRCUIT	GAUGE	COLOR	TERMINAL	SEAL/SLEEVE																																																												
A	K23	16	TN	1661875C1	1661872C1																																																												
B	K23-G	16	WH	1661875C1	1661872C1																																																												
<p>LOW COOLANT SENDER (6401) (LOCATED ON COOLANT RESERVOIR)</p>  <p>CONNECTOR 1671610C1 BODY LOCK 1671608C1</p> <table border="1" style="width:100%; border-collapse: collapse; font-size: x-small;"> <thead> <tr> <th>CAV</th> <th>CIR</th> <th>GAUGE</th> <th>COLOR</th> <th>TERMINAL</th> <th>SEAL/SLEEVE</th> </tr> </thead> <tbody> <tr> <td>A</td> <td>K34</td> <td>16</td> <td>TN</td> <td>2033819C1</td> <td>1652325C1</td> </tr> <tr> <td>B</td> <td>K34A</td> <td>16</td> <td>TN</td> <td>2033819C1</td> <td>1652325C1</td> </tr> </tbody> </table>		CAV	CIR	GAUGE	COLOR	TERMINAL	SEAL/SLEEVE	A	K34	16	TN	2033819C1	1652325C1	B	K34A	16	TN	2033819C1	1652325C1	<p>LOW COOLANT SENDER 8600 (6401) (W/ IBB ENGINE) (W/ PROSTAR)</p>  <p>CONNECTOR 1673746C1 BODY LOCK 1667873C1</p> <table border="1" style="width:100%; border-collapse: collapse; font-size: x-small;"> <thead> <tr> <th>CAV</th> <th>CIRCUIT</th> <th>GAUGE</th> <th>COLOR</th> <th>TERMINAL</th> <th>SEAL/SLEEVE</th> </tr> </thead> <tbody> <tr> <td>A</td> <td>K34D</td> <td>18</td> <td>TN</td> <td>1661875C1</td> <td>1661872C1</td> </tr> <tr> <td>B</td> <td>K34-GA</td> <td>18</td> <td>WH</td> <td>1661875C1</td> <td>1661872C1</td> </tr> <tr> <td>C</td> <td>K34B</td> <td>18</td> <td>TN</td> <td>1661875C1</td> <td>1661872C1</td> </tr> <tr> <td>D</td> <td>K34C</td> <td>18</td> <td>TN</td> <td>1661875C1</td> <td>1661872C1</td> </tr> </tbody> </table>				CAV	CIRCUIT	GAUGE	COLOR	TERMINAL	SEAL/SLEEVE	A	K34D	18	TN	1661875C1	1661872C1	B	K34-GA	18	WH	1661875C1	1661872C1	C	K34B	18	TN	1661875C1	1661872C1	D	K34C	18	TN	1661875C1	1661872C1												
CAV	CIR	GAUGE	COLOR	TERMINAL	SEAL/SLEEVE																																																												
A	K34	16	TN	2033819C1	1652325C1																																																												
B	K34A	16	TN	2033819C1	1652325C1																																																												
CAV	CIRCUIT	GAUGE	COLOR	TERMINAL	SEAL/SLEEVE																																																												
A	K34D	18	TN	1661875C1	1661872C1																																																												
B	K34-GA	18	WH	1661875C1	1661872C1																																																												
C	K34B	18	TN	1661875C1	1661872C1																																																												
D	K34C	18	TN	1661875C1	1661872C1																																																												
<p>LOW COOLANT SENSOR (6402) (LOCATED ON LEFT FRONT SIDE OF THE ENGINE)</p>  <p>CONNECTOR 1671610C1 BODY LOCK 1671608C1</p> <table border="1" style="width:100%; border-collapse: collapse; font-size: x-small;"> <thead> <tr> <th>CAV</th> <th>CIR</th> <th>GAUGE</th> <th>COLOR</th> <th>TERMINAL</th> <th>SEAL/SLEEVE</th> </tr> </thead> <tbody> <tr> <td>A</td> <td>K34</td> <td>16</td> <td>TN</td> <td>2033819C1</td> <td>1652325C1</td> </tr> <tr> <td>B</td> <td>K34A</td> <td>16</td> <td>TN</td> <td>2033819C1</td> <td>1652325C1</td> </tr> </tbody> </table>		CAV	CIR	GAUGE	COLOR	TERMINAL	SEAL/SLEEVE	A	K34	16	TN	2033819C1	1652325C1	B	K34A	16	TN	2033819C1	1652325C1	<p>TRAILER SOCKET 2 (6403) (LOCATED ON LEFT FRONT SIDE OF THE ENGINE)</p>  <p>CONNECTOR 1671610C1 BODY LOCK 1671608C1</p> <table border="1" style="width:100%; border-collapse: collapse; font-size: x-small;"> <thead> <tr> <th>CAV</th> <th>CIR</th> <th>GAUGE</th> <th>COLOR</th> <th>TERMINAL</th> <th>SEAL/SLEEVE</th> </tr> </thead> <tbody> <tr> <td>A</td> <td>K23</td> <td>16</td> <td>TN</td> <td>2033819C1</td> <td>1652325C1</td> </tr> <tr> <td>B</td> <td>K23-G</td> <td>16</td> <td>WH</td> <td>2033819C1</td> <td>1652325C1</td> </tr> </tbody> </table>				CAV	CIR	GAUGE	COLOR	TERMINAL	SEAL/SLEEVE	A	K23	16	TN	2033819C1	1652325C1	B	K23-G	16	WH	2033819C1	1652325C1																								
CAV	CIR	GAUGE	COLOR	TERMINAL	SEAL/SLEEVE																																																												
A	K34	16	TN	2033819C1	1652325C1																																																												
B	K34A	16	TN	2033819C1	1652325C1																																																												
CAV	CIR	GAUGE	COLOR	TERMINAL	SEAL/SLEEVE																																																												
A	K23	16	TN	2033819C1	1652325C1																																																												
B	K23-G	16	WH	2033819C1	1652325C1																																																												
<p>LOW COOLANT SENSOR (6403) (W/ CAT ENGINE)</p>  <p>CONNECTOR 1673746C1 BODY LOCK 1667873C1</p> <table border="1" style="width:100%; border-collapse: collapse; font-size: x-small;"> <thead> <tr> <th>CAV</th> <th>CIRCUIT</th> <th>GAUGE</th> <th>COLOR</th> <th>TERMINAL</th> <th>SEAL/SLEEVE</th> </tr> </thead> <tbody> <tr> <td>A</td> <td>K34D</td> <td>16</td> <td>TN</td> <td>1661875C1</td> <td>1661872C1</td> </tr> <tr> <td>B</td> <td>K34-GA</td> <td>16</td> <td>WH</td> <td>1661875C1</td> <td>1661872C1</td> </tr> <tr> <td>C</td> <td>K34B</td> <td>16</td> <td>TN</td> <td>1661875C1</td> <td>1661872C1</td> </tr> <tr> <td>D</td> <td>K34C</td> <td>16</td> <td>TN</td> <td>1661875C1</td> <td>1661872C1</td> </tr> </tbody> </table>		CAV	CIRCUIT	GAUGE	COLOR	TERMINAL	SEAL/SLEEVE	A	K34D	16	TN	1661875C1	1661872C1	B	K34-GA	16	WH	1661875C1	1661872C1	C	K34B	16	TN	1661875C1	1661872C1	D	K34C	16	TN	1661875C1	1661872C1	<p>VARIABLE SPEED FAN DRIVE (6406 / *6402) (LOCATED ON LEFT FRONT SIDE OF THE ENGINE)</p>  <p>CONNECTOR 3540756C1 BODY LOCK 3540758C1</p> <p>* W/ CAT ENGINE</p> <table border="1" style="width:100%; border-collapse: collapse; font-size: x-small;"> <thead> <tr> <th>CAV</th> <th>CIR</th> <th>GAUGE</th> <th>COLOR</th> <th>TERMINAL</th> <th>SEAL/SLEEVE</th> </tr> </thead> <tbody> <tr> <td>A</td> <td>K23</td> <td>16</td> <td>TN</td> <td>1661875C1</td> <td>1661872C1</td> </tr> <tr> <td>B</td> <td>K9AD</td> <td>18</td> <td>GY</td> <td>1661875C1</td> <td>1661872C1</td> </tr> <tr> <td>C</td> <td>K23A</td> <td>16</td> <td>TN</td> <td>1661875C1</td> <td>1661872C1</td> </tr> <tr> <td>D</td> <td>K23-G</td> <td>16</td> <td>WH</td> <td>1661875C1</td> <td>1661872C1</td> </tr> </tbody> </table>				CAV	CIR	GAUGE	COLOR	TERMINAL	SEAL/SLEEVE	A	K23	16	TN	1661875C1	1661872C1	B	K9AD	18	GY	1661875C1	1661872C1	C	K23A	16	TN	1661875C1	1661872C1	D	K23-G	16	WH	1661875C1	1661872C1
CAV	CIRCUIT	GAUGE	COLOR	TERMINAL	SEAL/SLEEVE																																																												
A	K34D	16	TN	1661875C1	1661872C1																																																												
B	K34-GA	16	WH	1661875C1	1661872C1																																																												
C	K34B	16	TN	1661875C1	1661872C1																																																												
D	K34C	16	TN	1661875C1	1661872C1																																																												
CAV	CIR	GAUGE	COLOR	TERMINAL	SEAL/SLEEVE																																																												
A	K23	16	TN	1661875C1	1661872C1																																																												
B	K9AD	18	GY	1661875C1	1661872C1																																																												
C	K23A	16	TN	1661875C1	1661872C1																																																												
D	K23-G	16	WH	1661875C1	1661872C1																																																												
CHK	DATE	CHANGE	REV	REFERENCE	DRAWN	NAME																																																											
CNA1	14JAN09	TITLE WAS CIRCUIT	D	61254R	U00K640	CIRCUIT DIAGRAM, PROSTAR, LONESTAR																																																											
DIAGRAM, PROSTAR					59637L	DATE PART NO. SHEET																																																											
						08SEP06 AE08055906 086																																																											

Figure 342 Connector Composites (6400), (6401), (6402), (6403), (6406/6402)

**14.114. CONNECTOR COMPOSITES (6420), (6550), (6551), (6561), (6650), (6700), (6701), P. 86A**



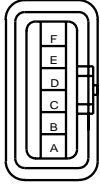
**Figure 343 Connector Composites (6420), (6550), (6551), (6561), (6650), (6700), (6701)**

14.115. CONNECTOR COMPOSITES (6702), (6703), (6703/6703A), (6704), (6704A), P. 87

INTERNATIONAL TRUCK AND ENGINE CORPORATION		ELECTRICAL CIRCUIT DIAGRAM		CHAPTER 14	
THIS PRINT IS PROVIDED ON A RESTRICTED BASIS AND IS NOT TO BE USED IN ANY WAY DETRIMENTAL TO THE INTEREST OF INTERNATIONAL TRUCK AND ENGINE CORPORATION.		CONNECTOR BODY COMPOSITE - MATING VIEW SHOWN			

0V REFERENCE SPLICE  
(6702)  
(LOCATED UPPER REAR OF ENGINE)



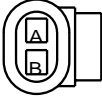
CONNECTOR 3543729C1  
BODY LOCK 3543731C1

CAV	CIR	GAUGE	COLOR	TERMINAL	SEAL/SLEEVE
A	K9AA	16	GY	3535303C1	3535424C1
B	K9AAA	18	GY	3535303C1	3535424C1
B*	K9AB	18	GY	3535303C1	3535424C1
C	K9AAD	18	GY	3535303C1	3535424C1
C*	K9AC	18	GY	3535303C1	3535424C1
D	K9AAB	18	GY	3535303C1	3535424C1
D*	K30B	18	TN	3535303C1	3535424C1
E	PLUG	-	-	3535425C1	-
E*	K9AD	18	GY	3535303C1	3535424C1
F	PLUG	-	-	3535425C1	-
F*	K9AAB	18	GY	3535303C1	3535424C1

\* W/ CAT ENGINE

AIR RESTRICTION GAUGE  
(6703 / #6703A)  
(LOCATED ON AIR CLEANER - LEFT REAR OF ENG)

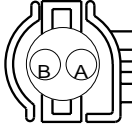


CONNECTOR 3522068C1  
BODY LOCK 1661874C1

# W/ IBB & CAT ENGINE

CAV	CIR	GAUGE	COLOR	TERMINAL	SEAL/SLEEVE
A	K9AAB	18	GY	1661875C1	1661872C1
B	K28	18	TN	1661875C1	1661872C1

INTAKE AIR TEMPERATURE  
(6703)  
(LOCATED ON AIR FILTER HOUSING)  
(W/ IBB ENGINE)  
(W/ PROSTAR)

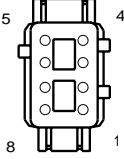


CONNECTOR 1689462C1  
BODY LOCK 1689463C1

CAV	CIRCUIT	GAUGE	COLOR	TERMINAL
A	K41	16	TN	1689464C1
B	K41-G	16	WH	1689464C1

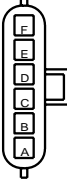
FLEETGUARD AFTER TREATMENT HARNESS  
(6704)  
(LOCATED ON RIGHT SIDE OF BELL HOUSING)



CONNECTOR 3539139C1  
BODY LOCK 3539144C1

CAV	CIR	GAUGE	COLOR	TERMINAL
1	K95A	18	TN	3555249C1
2	K95B	18	TN	3555249C1
3	K95C	18	TN	3555249C1
4	K95-GA	18	WH	3555249C1
5	K95D	18	TN	3555249C1
6	K95E	18	TN	3555249C1
7	K95-GB	18	WH	3555249C1
8	PLUG	-	-	3527276C1

GROUND ADAPTER (6704A)  
(W/ IBB ENGINE)  
(W/ PROSTAR)



CONNECTOR 3551896C1  
BODY LOCK 3551897C1

\* MUTUALLY EXCLUSIVE

CAV	CIRCUIT	GAUGE	COLOR	TERMINAL	SEAL/SLEEVE
A	K10-GB	10	WH	1687847C1	0589390C1
B	K10WH1	18	WH	2033819C1	3517771C1
C	K77-G	16	WH	2033819C1	1652325C1
D	K10-G	16	WH	2033819C1	1652325C1
E*	K23-G	16	WH	2033819C1	1652325C1
E*	K23-G	18	TN	2033819C1	1652325C1
F	PLUG	-	-	0587579C1	-

CHK	DATE	CHANGE	REV	REFERENCE	DRAWN	NAME
CNA1	14JAN09	TITLE WAS CIRCUIT	C	61254R	U00K640	CIRCUIT DIAGRAM, PROSTAR, LONESTAR
		DIAGRAM, PROSTAR			59637L	08SEP06 AE08055906 087

Figure 344 Connector Composites (6702), (6703), (6703/6703A), (6704), (6704A)

14.116. CONNECTOR COMPOSITES (6705), (6706), (6707), P. 88

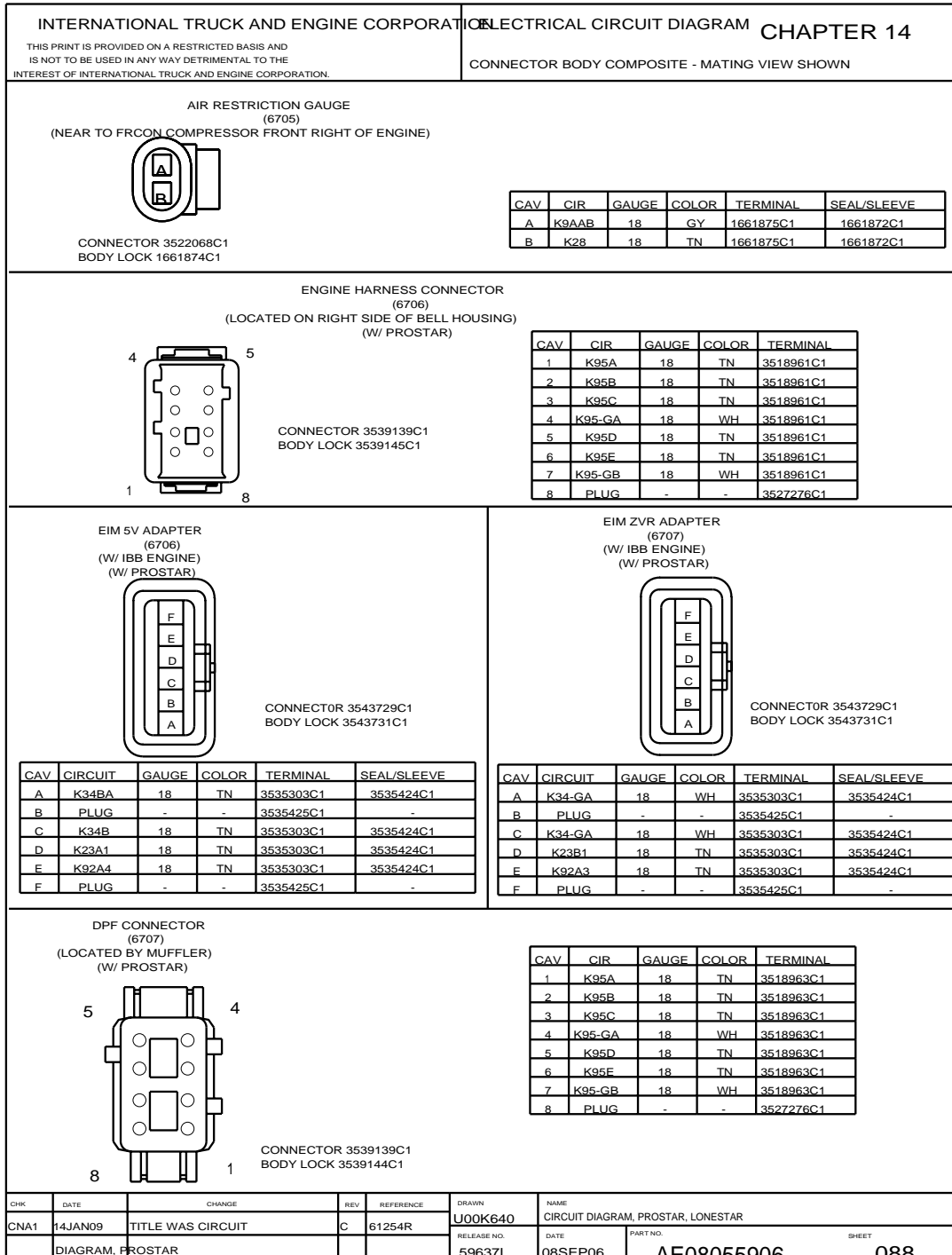


Figure 345 Connector Composites (6705), (6706), (6707)

14.117. CONNECTOR COMPOSITES (6708), (6709), (6712), (6713), (6714), P. 88A

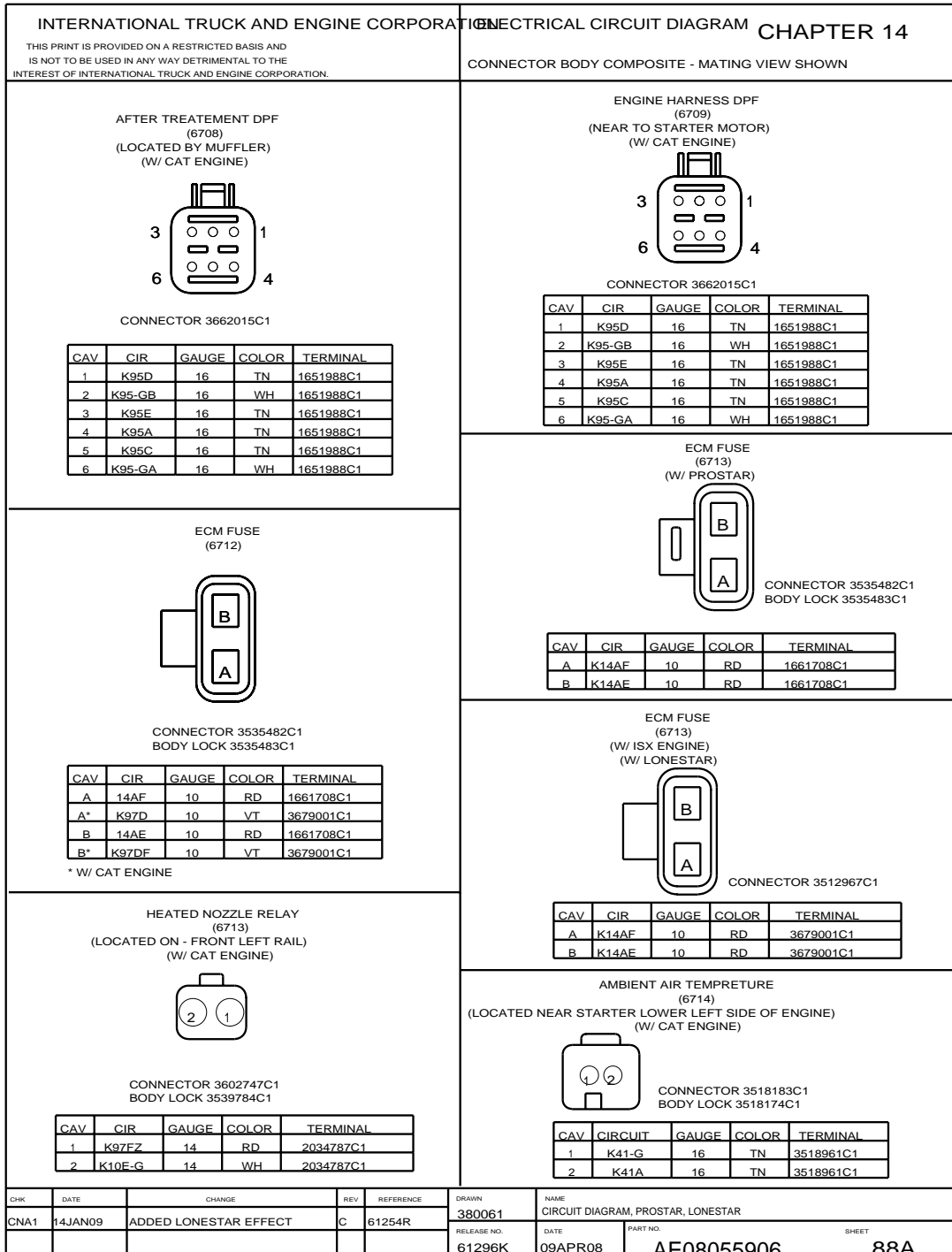


Figure 346 Connector Composites (6708), (6709), (6712), (6713), (6714)

14.118. CONNECTOR COMPOSITES (6715), (6716), (6716A), (6720/6721), (6730), P. 88B

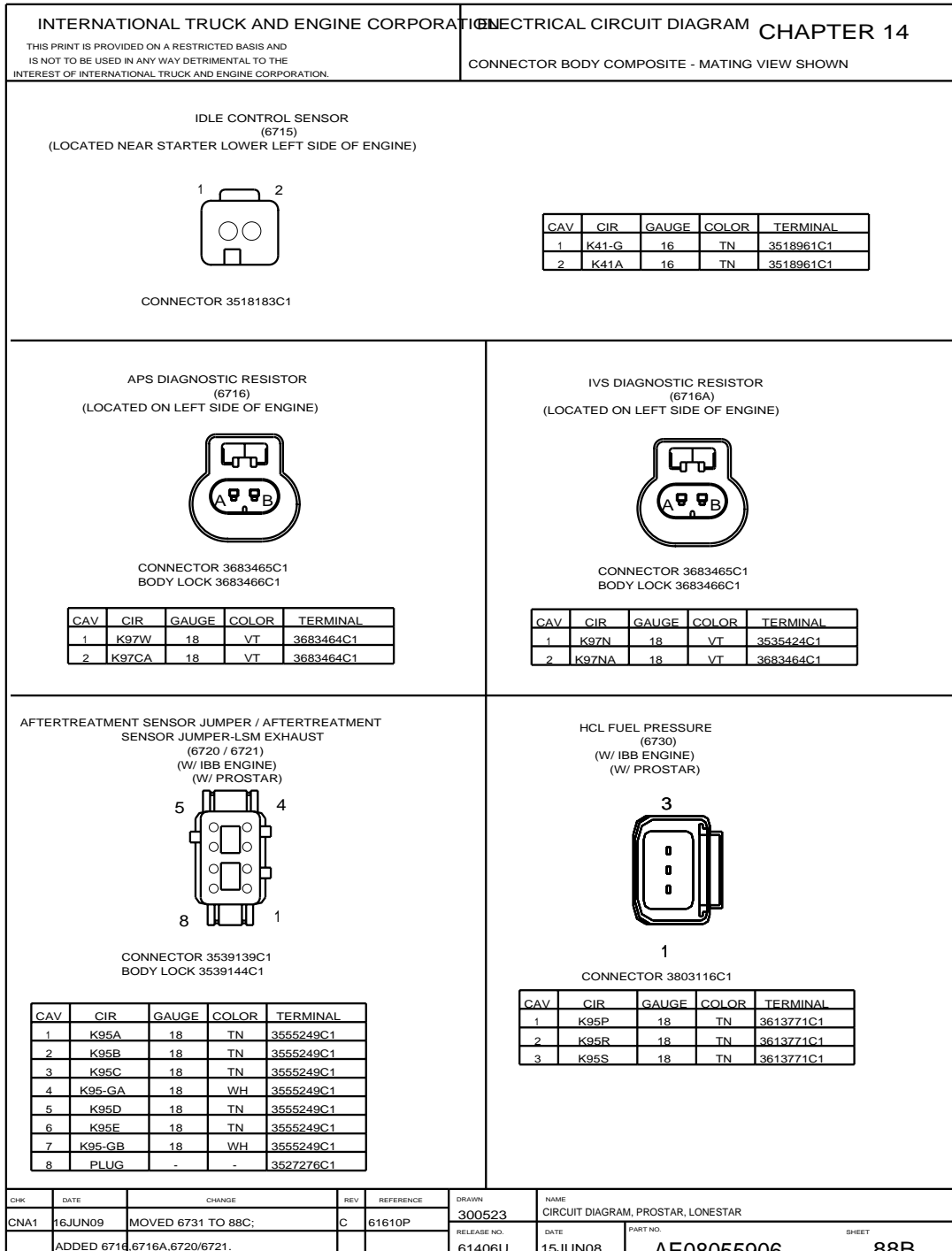


Figure 347 Connector Composites (6715), (6716), (6716A), (6720/6721), (6730)

14.119. CONNECTOR COMPOSITES (6725), (6731/6731A), P. 88C

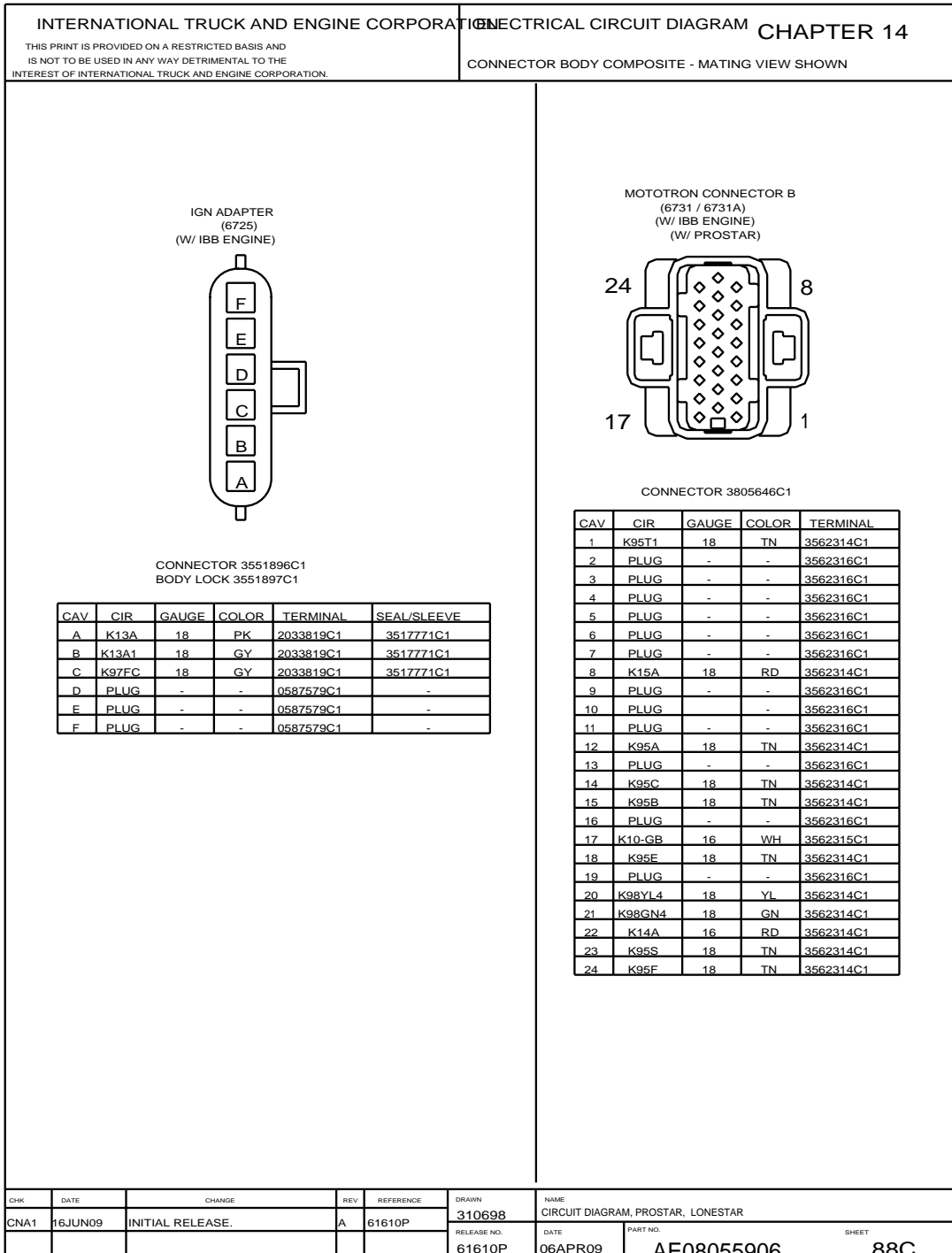


Figure 348 Connector Composites (6725), (6731/6731A)

14.120. CONNECTOR COMPOSITES (6732), (7103), (7104), P. 89

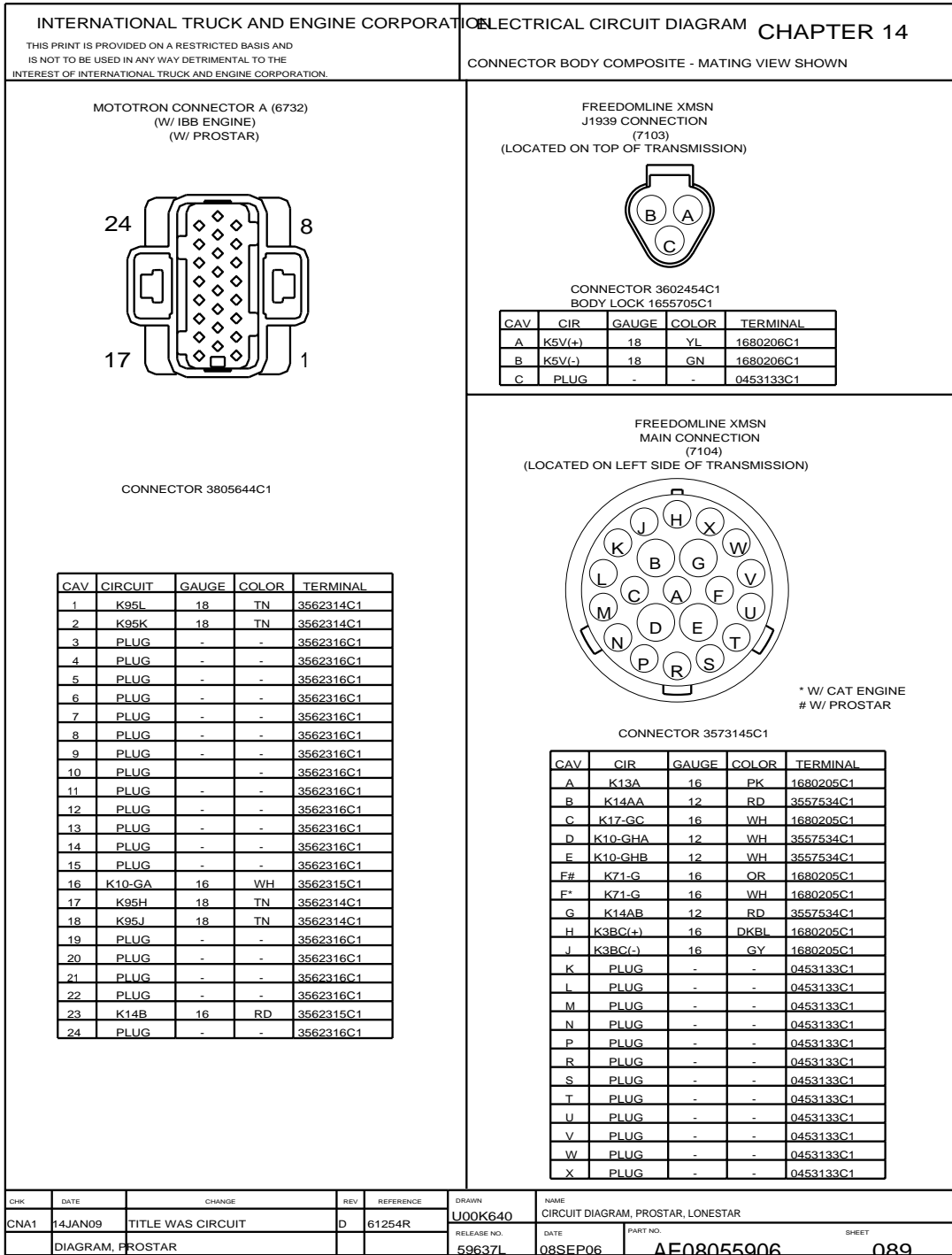
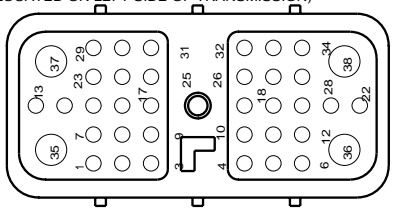



Figure 349 Connector Composites (6732), (7103), (7104)

14.121. CONNECTOR COMPOSITES (7105), (7107/7110), (7111), (7500/7500A), P. 90

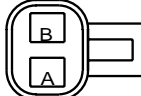
INTERNATIONAL TRUCK AND ENGINE CORPORATION <small>THIS PRINT IS PROVIDED ON A RESTRICTED BASIS AND IS NOT TO BE USED IN ANY WAY DETRIMENTAL TO THE INTEREST OF INTERNATIONAL TRUCK AND ENGINE CORPORATION.</small>		ELECTRICAL CIRCUIT DIAGRAM CHAPTER 14 CONNECTOR BODY COMPOSITE - MATING VIEW SHOWN			
EATON GEN3 TCM CONNECTOR (7105) (LOCATED ON LEFT SIDE OF TRANSMISSION)		J1939 (7107 / &7110) (LOCATED ON TRANSMISSION HARNESS)			
					
CONNECTOR 3599542C1 @ W/ PROSTAR		CONNECTOR 1667741C1 BODY LOCK 1667771C1			
* MUTUALLY EXCLUSIVE # W/ CAT ENGINE % W/ IBB ENGINE					
CAV	CIR	GAUGE	COLOR	TERMINAL	SEAL/SLEEVE
1	PLUG	-	-	3527276C1	
2	K5V(-)	18	GN	3555249C1	
3	K5V(+)	18	YL	3555249C1	
4*	K17-GC	18	WH	3555249C1	
4* @%	K17-GC	18	PK	3555249C1	
5	PLUG	-	-	3527276C1	
6	PLUG	-	-	3527276C1	
7	PLUG	-	-	3527276C1	
8	PLUG	-	-	3527276C1	
9	PLUG	-	-	3527276C1	
10	K3BC(+)	18	DKBL	3555249C1	
11	K3BC(-)	18	GY	3555249C1	
12	PLUG	-	-	3527276C1	
13	PLUG	-	-	3527276C1	
14	PLUG	-	-	3527276C1	
15	PLUG	-	-	3527276C1	
16	K92A	18	TN	3555249C1	
17	K92B	18	TN	3555249C1	
18	PLUG	-	-	3527276C1	
19	PLUG	-	-	3527276C1	
20*	K92E	18	TN	3555249C1	
20* @%	K92E	16	TN	3555249C1	
21	K92F	18	TN	3555249C1	
22	K92H	18	TN	3555249C1	
23	PLUG	-	-	3527276C1	
24	PLUG	-	-	3527276C1	
25%	K92J	18	TN	3555249C1	
26*	K17C	18	PK	3555249C1	
26* @%	K17C	16	PK	3555249C1	
27%	K98GN	18	GN	3555249C1	
28%	K98YL	18	YL	3555249C1	
29	PLUG	-	-	3527276C1	
30	PLUG	-	-	3527276C1	
31%	K92ER	18	TN	3555249C1	
32	K17B	18	PK	3555249C1	
33	PLUG	-	-	3527276C1	
34	PLUG	-	-	3527276C1	
35*	K13AA	12	PK	3557534C1	
35* %	K13A	14	PK	3557534C1	
36* %	K10-GE	12	WH	3557534C1	
36* #	K11-GE	12	WH	3557534C1	
37	PLUG	-	-	3527276C1	
38	K14A	12	RD	3557534C1	


CAV	CIR	GAUGE	COLOR	TERMINAL	SEAL/SLEEVE
A	K5TB(+)	18	YL	1661875C1	3568570C1
B	PLUG	-	-	2025431C1	-
C	K5TB(-)	18	GN	1661875C1	3568570C1

& W/ IBB AND CAT ENGINE  
# W/ MANUAL XMSN  
% W/ MERITOR-G XMSN  
@ W/ AUTOSHIFT AND ULTRASHIFT XMSN

MERITOR G POWER (7111) (LOCATED ON LEFT SIDE OF TRANSMISSION) (W/ PROSTAR)					
					
CONNECTOR 1671610C1 BODY LOCK 1671608C1					
CAV	CIR	GAUGE	COLOR	TERMINAL	SEAL/SLEEVE
A	K13A	16	PK	2033819C1	1652325C1
B	K10-GX	16	WH	2033819C1	1652325C1

BACK-UP LIGHT (7500 / &7500A) (LOCATED ON TOP REAR OF TRANSMISSION)					
					
CONNECTOR 1661778C1 BODY LOCK 1661874C1					
CAV	CIR	GAUGE	COLOR	TERMINAL	SEAL/SLEEVE
A	K71A	16	OR	1661875C1	1661872C1
B	K71B	16	OR	1661875C1	1661872C1

& W/ IBB AND CAT ENGINE

Figure 350 Connector Composites (7105), (7107/7110), (7111), (7500/7500A)

14.122. CONNECTOR COMPOSITES (7500W), (7600), (7600A), (7616), P. 91

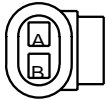
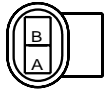
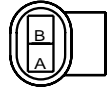
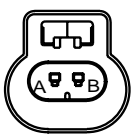
INTERNATIONAL TRUCK AND ENGINE CORPORATION				ELECTRICAL CIRCUIT DIAGRAM CHAPTER 14							
THIS PRINT IS PROVIDED ON A RESTRICTED BASIS AND IS NOT TO BE USED IN ANY WAY DETRIMENTAL TO THE INTEREST OF INTERNATIONAL TRUCK AND ENGINE CORPORATION.				CONNECTOR BODY COMPOSITE - MATING VIEW SHOWN							
REVERSE LIGHT (7500W) (LOCATED ON TOP OF TRANSMISSION) (W/ PROSTAR)				VEHICLE SPEED SENSOR (7600) (LOCATED ON TOP OF TRANSMISSION) (W/ PROSTAR)							
											
CONNECTOR 1661778C1 BODY LOCK 1661874C1				CONNECTOR 3662425C1 BODY LOCK 3662518C1							
CAV	CIR	GAUGE	COLOR	TERMINAL	SEAL/SLEEVE	CAV	CIR	GAUGE	COLOR	TERMINAL	SEAL/SLEEVE
A	K71A	16	OR	1661875C1	1661872C1	A	K47	18	GY	3554322C1	3554318C1
B	K71B	16	OR	1661875C1	1661872C1	A*	K47D1	18	GY	3554322C1	3554318C1
						B*	K47E1	18	GY	3554322C1	3554318C1
						B	K47A	18	GY	3554322C1	3554318C1
* W/MANUAL XMSN & W/ODOMETER SHUT-OFF											
SPEED SENSOR (7600A) (LOCATED ON REAR OF TRANSMISSION) (W/ IBB & CAT ENGINE)				ODOMETER SHUT-OFF RESISTOR (7616) (LOCATED ON TRANSMISSION HARNESS) (W/ IBB ENGINE)							
											
CONNECTOR 2036583C1				CONNECTOR 3683465C1 BODY LOCK 3683466C1							
CAV	CIR	GAUGE	COLOR	TERMINAL	SEAL/SLEEVE	CAV	CIR	GAUGE	COLOR	TERMINAL	SEAL/SLEEVE
A	K47	16	GY	2036586C1		A	K47D2	18	GY	3683464C1	3535424C1
B	K47A	16	GY	2036586C1		B	K47E2	18	GY	3683464C1	3535424C1
CHK	DATE	CHANGE	REV	REFERENCE	DRAWN	NAME					
CNA1	16JUN09	REVISED AND REDRAWN.	D	61610P	U00K640	CIRCUIT DIAGRAM, PROSTAR, LONESTAR					
					RELEASE NO.	DATE	PART NO.	SHEET			
					59637L	08SEP06	AE08055906	091			

Figure 351 Connector Composites (7500W), (7600), (7600A), (7616)

14.123. CONNECTOR COMPOSITES (7617), (7700/7700L/7700K), (7802), (7905), P. 91A

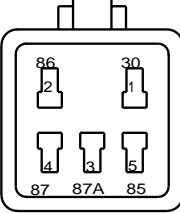
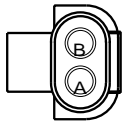

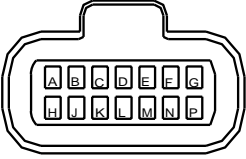
INTERNATIONAL TRUCK AND ENGINE CORPORATION		ELECTRICAL CIRCUIT DIAGRAM		CHAPTER 14																																																																																																																																											
THIS PRINT IS PROVIDED ON A RESTRICTED BASIS AND IS NOT TO BE USED IN ANY WAY DETRIMENTAL TO THE INTEREST OF INTERNATIONAL TRUCK AND ENGINE CORPORATION.		CONNECTOR BODY COMPOSITE - MATING VIEW SHOWN																																																																																																																																													
<p>ODOMETER SHUT OFF RELAY (7617) (LOCATED ON LEFT SIDE OF TRANSMISSION) (W/IBB ENGINE)</p>  <p>CONNECTOR 3512331C91</p> <table border="1" style="width:100%; border-collapse: collapse; font-size: x-small;"> <thead> <tr> <th>CAV</th> <th>CIR</th> <th>GAUGE</th> <th>COLOR</th> <th>TERMINAL</th> <th>SEAL/SLEEVE</th> </tr> </thead> <tbody> <tr><td>1</td><td>K47D</td><td>18</td><td>GY</td><td>2039343C1</td><td>3517771C1</td></tr> <tr><td>2</td><td>K47TC</td><td>18</td><td>GY</td><td>2039343C1</td><td>3517771C1</td></tr> <tr><td>3</td><td>K47D1</td><td>18</td><td>GY</td><td>2039343C1</td><td>3517771C1</td></tr> <tr><td>4</td><td>K47D2</td><td>18</td><td>GY</td><td>2039343C1</td><td>3517771C1</td></tr> <tr><td>5</td><td>K97FC</td><td>18</td><td>GY</td><td>2039343C1</td><td>3517771C1</td></tr> </tbody> </table>			CAV	CIR	GAUGE	COLOR	TERMINAL	SEAL/SLEEVE	1	K47D	18	GY	2039343C1	3517771C1	2	K47TC	18	GY	2039343C1	3517771C1	3	K47D1	18	GY	2039343C1	3517771C1	4	K47D2	18	GY	2039343C1	3517771C1	5	K97FC	18	GY	2039343C1	3517771C1	<p>NEUTRAL SWITCH (7802) (LOCATED ON TOP OF TRANSMISSION)</p>  <p>CONNECTOR 3593684C91 #3540054C91</p> <table border="1" style="width:100%; border-collapse: collapse; font-size: x-small;"> <thead> <tr> <th>CAV</th> <th>CIR</th> <th>GAUGE</th> <th>COLOR</th> <th>TERMINAL</th> <th>SEAL/SLEEVE</th> </tr> </thead> <tbody> <tr><td>A</td><td>K97J</td><td>18</td><td>VT</td><td>0587578C1</td><td>1652325C1</td></tr> <tr><td>B</td><td>K97S</td><td>18</td><td>VT</td><td>0587578C1</td><td>1652325C1</td></tr> </tbody> </table> <p># W/ LONESTAR</p>			CAV	CIR	GAUGE	COLOR	TERMINAL	SEAL/SLEEVE	A	K97J	18	VT	0587578C1	1652325C1	B	K97S	18	VT	0587578C1	1652325C1																																																																																				
CAV	CIR	GAUGE	COLOR	TERMINAL	SEAL/SLEEVE																																																																																																																																										
1	K47D	18	GY	2039343C1	3517771C1																																																																																																																																										
2	K47TC	18	GY	2039343C1	3517771C1																																																																																																																																										
3	K47D1	18	GY	2039343C1	3517771C1																																																																																																																																										
4	K47D2	18	GY	2039343C1	3517771C1																																																																																																																																										
5	K97FC	18	GY	2039343C1	3517771C1																																																																																																																																										
CAV	CIR	GAUGE	COLOR	TERMINAL	SEAL/SLEEVE																																																																																																																																										
A	K97J	18	VT	0587578C1	1652325C1																																																																																																																																										
B	K97S	18	VT	0587578C1	1652325C1																																																																																																																																										
<p>TRANSMISSION OIL TEMP SENSOR (7700 / **7700L / 7700K) (LOCATED ON UNDERSIDE OF TRANSMISSION)</p>  <p>CONNECTOR 3536864C1</p> <table border="1" style="width:100%; border-collapse: collapse; font-size: x-small;"> <thead> <tr> <th>CAV</th> <th>CIR</th> <th>GAUGE</th> <th>COLOR</th> <th>TERMINAL</th> <th>SEAL/SLEEVE</th> </tr> </thead> <tbody> <tr><td>1</td><td>K31</td><td>18</td><td>TN</td><td>3536865C1</td><td>3536868C1</td></tr> <tr><td>1**</td><td>K31H</td><td>18</td><td>TN</td><td>3561584C1</td><td>3536868C1</td></tr> <tr><td>2&amp;</td><td>K9AAD</td><td>18</td><td>GY</td><td>3536865C1</td><td>3536868C1</td></tr> <tr><td>2*</td><td>K9AA</td><td>16</td><td>GY</td><td>3561584C1</td><td>3536868C1</td></tr> <tr><td>2#</td><td>K9AC</td><td>18</td><td>GY</td><td>3561584C1</td><td>3536868C1</td></tr> <tr><td>2@</td><td>K9AAD</td><td>18</td><td>GY</td><td>3561584C1</td><td>3536868C1</td></tr> <tr><td>2**</td><td>K9AAD</td><td>18</td><td>GY</td><td>3561584C1</td><td>3536868C1</td></tr> </tbody> </table> <p>&amp; W/ ISX ENGINE * W/ IBB / CAT ENGINE N/ AC @ W/ IBB ENGINE W/ AC # W/ CAT ENGINE W/ AC ** W/ CAT ENGINE W/ FREEDOMLINE XMSN</p>			CAV	CIR	GAUGE	COLOR	TERMINAL	SEAL/SLEEVE	1	K31	18	TN	3536865C1	3536868C1	1**	K31H	18	TN	3561584C1	3536868C1	2&	K9AAD	18	GY	3536865C1	3536868C1	2*	K9AA	16	GY	3561584C1	3536868C1	2#	K9AC	18	GY	3561584C1	3536868C1	2@	K9AAD	18	GY	3561584C1	3536868C1	2**	K9AAD	18	GY	3561584C1	3536868C1	<p>SHIFTER CONNECTION (7905) (LOCATED ON SHIFTER MODULE)</p>  <p>CONNECTOR 3601746C1</p> <table border="1" style="width:100%; border-collapse: collapse; font-size: x-small;"> <thead> <tr> <th>CAV</th> <th>CIR</th> <th>GAUGE</th> <th>COLOR</th> <th>TERMINAL</th> <th>SEAL/SLEEVE</th> </tr> </thead> <tbody> <tr><td>A</td><td>PLUG</td><td>-</td><td>-</td><td>3535425C1</td><td>-</td></tr> <tr><td>B</td><td>A92-G</td><td>16</td><td>WH</td><td>3535303C1</td><td>3535424C1</td></tr> <tr><td>C</td><td>A92VA</td><td>16</td><td>TN</td><td>3535303C1</td><td>3535424C1</td></tr> <tr><td>D</td><td>A92UA</td><td>18</td><td>TN</td><td>3535303C1</td><td>3535424C1</td></tr> <tr><td>E</td><td>PLUG</td><td>-</td><td>-</td><td>3535425C1</td><td>-</td></tr> <tr><td>F</td><td>A5FA(+)</td><td>18</td><td>YL</td><td>3535303C1</td><td>3535424C1</td></tr> <tr><td>G</td><td>A5FA(-)</td><td>18</td><td>GN</td><td>3535303C1</td><td>3535424C1</td></tr> <tr><td>H</td><td>PLUG</td><td>-</td><td>-</td><td>3535425C1</td><td>-</td></tr> <tr><td>J</td><td>A62BE</td><td>18</td><td>DKBL</td><td>3535303C1</td><td>3535424C1</td></tr> <tr><td>K</td><td>A92A</td><td>18</td><td>GY</td><td>3535303C1</td><td>3535424C1</td></tr> <tr><td>L</td><td>A92</td><td>18</td><td>TN</td><td>3535303C1</td><td>3535424C1</td></tr> <tr><td>M</td><td>PLUG</td><td>-</td><td>-</td><td>3535425C1</td><td>-</td></tr> <tr><td>N</td><td>A92A</td><td>18</td><td>TN</td><td>3535303C1</td><td>3535424C1</td></tr> <tr><td>P</td><td>A92B</td><td>18</td><td>TN</td><td>3535303C1</td><td>3535424C1</td></tr> </tbody> </table>			CAV	CIR	GAUGE	COLOR	TERMINAL	SEAL/SLEEVE	A	PLUG	-	-	3535425C1	-	B	A92-G	16	WH	3535303C1	3535424C1	C	A92VA	16	TN	3535303C1	3535424C1	D	A92UA	18	TN	3535303C1	3535424C1	E	PLUG	-	-	3535425C1	-	F	A5FA(+)	18	YL	3535303C1	3535424C1	G	A5FA(-)	18	GN	3535303C1	3535424C1	H	PLUG	-	-	3535425C1	-	J	A62BE	18	DKBL	3535303C1	3535424C1	K	A92A	18	GY	3535303C1	3535424C1	L	A92	18	TN	3535303C1	3535424C1	M	PLUG	-	-	3535425C1	-	N	A92A	18	TN	3535303C1	3535424C1	P	A92B	18	TN	3535303C1	3535424C1
CAV	CIR	GAUGE	COLOR	TERMINAL	SEAL/SLEEVE																																																																																																																																										
1	K31	18	TN	3536865C1	3536868C1																																																																																																																																										
1**	K31H	18	TN	3561584C1	3536868C1																																																																																																																																										
2&	K9AAD	18	GY	3536865C1	3536868C1																																																																																																																																										
2*	K9AA	16	GY	3561584C1	3536868C1																																																																																																																																										
2#	K9AC	18	GY	3561584C1	3536868C1																																																																																																																																										
2@	K9AAD	18	GY	3561584C1	3536868C1																																																																																																																																										
2**	K9AAD	18	GY	3561584C1	3536868C1																																																																																																																																										
CAV	CIR	GAUGE	COLOR	TERMINAL	SEAL/SLEEVE																																																																																																																																										
A	PLUG	-	-	3535425C1	-																																																																																																																																										
B	A92-G	16	WH	3535303C1	3535424C1																																																																																																																																										
C	A92VA	16	TN	3535303C1	3535424C1																																																																																																																																										
D	A92UA	18	TN	3535303C1	3535424C1																																																																																																																																										
E	PLUG	-	-	3535425C1	-																																																																																																																																										
F	A5FA(+)	18	YL	3535303C1	3535424C1																																																																																																																																										
G	A5FA(-)	18	GN	3535303C1	3535424C1																																																																																																																																										
H	PLUG	-	-	3535425C1	-																																																																																																																																										
J	A62BE	18	DKBL	3535303C1	3535424C1																																																																																																																																										
K	A92A	18	GY	3535303C1	3535424C1																																																																																																																																										
L	A92	18	TN	3535303C1	3535424C1																																																																																																																																										
M	PLUG	-	-	3535425C1	-																																																																																																																																										
N	A92A	18	TN	3535303C1	3535424C1																																																																																																																																										
P	A92B	18	TN	3535303C1	3535424C1																																																																																																																																										
CHK	DATE	CHANGE	REV	REFERENCE	DRAWN	NAME																																																																																																																																									
CNA1	16JUN09	INITIAL RELEASE.	A	61610P	310698	CIRCUIT DIAGRAM, PROSTAR, LONESTAR																																																																																																																																									
					RELEASE NO.	DATE																																																																																																																																									
					61610P	06APR09																																																																																																																																									
						PART NO.																																																																																																																																									
						AE08055906																																																																																																																																									
						SHEET																																																																																																																																									
						91A																																																																																																																																									

Figure 352 Connector Composites (7617), (7700/7700L/7700K), (7802), (7905)

14.124. CONNECTOR COMPOSITES (8000), (8001), (8001/8001F), P. 92

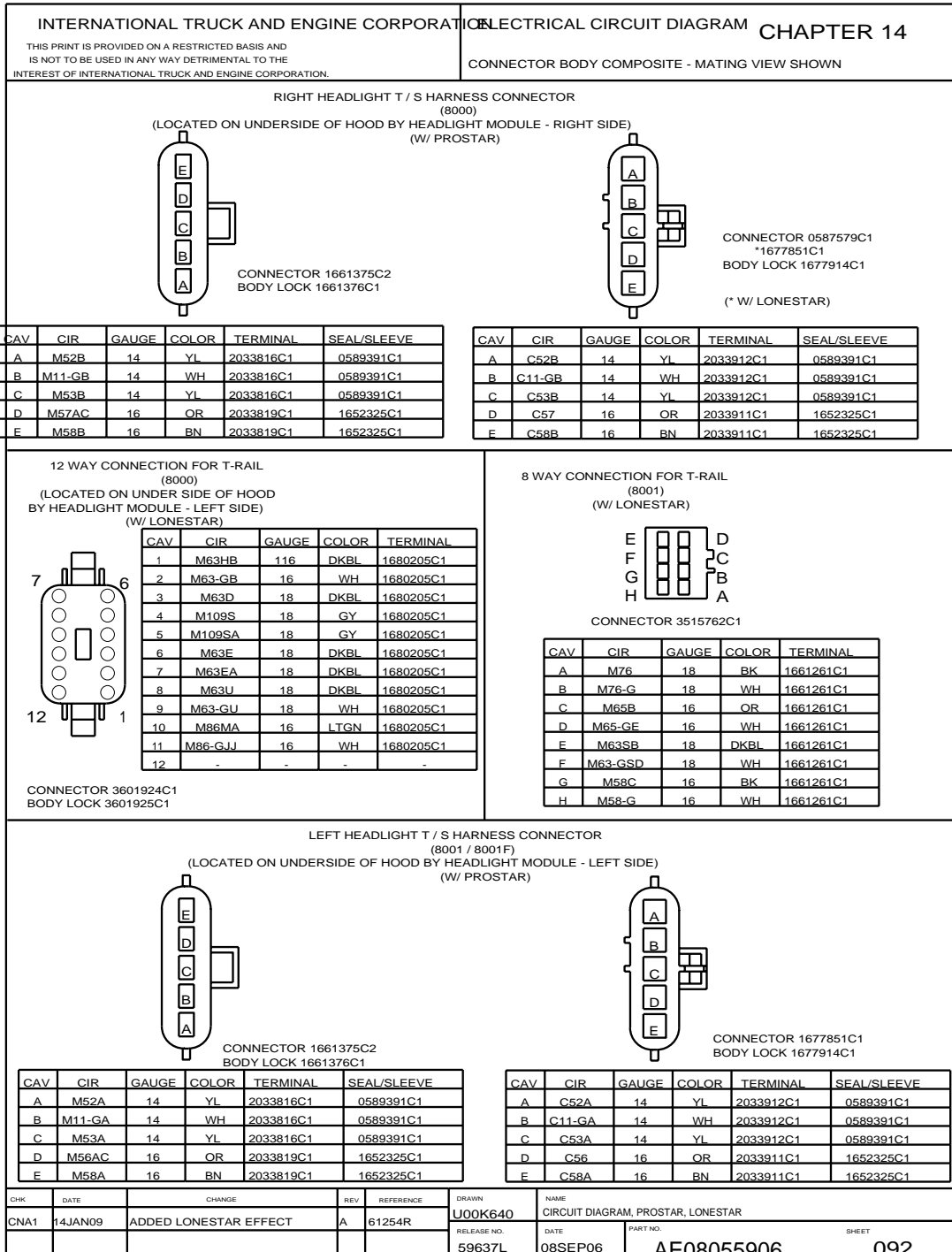


Figure 353 Connector Composites (8000), (8001), (8001/8001F)

14.125. CONNECTOR COMPOSITES (8002), (8003), (8006R), (8006T), (8050), (8051), P. 93

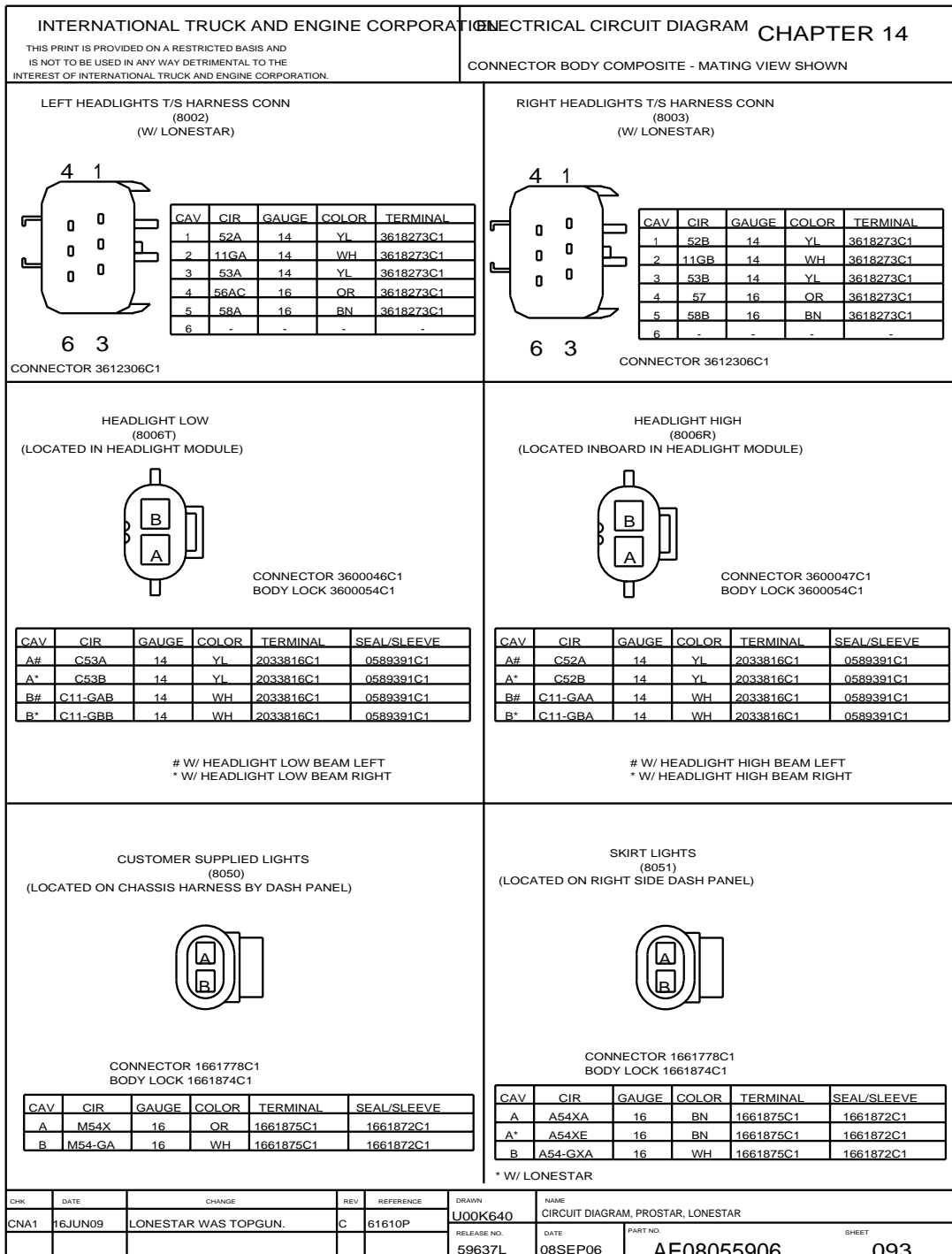


Figure 354 Connector Composites (8002), (8003), (8006R), (8006T), (8050), (8051)

14.126. CONNECTOR COMPOSITES (8052), (8053), (8100), (8100A), (8100B), P. 93A

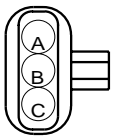
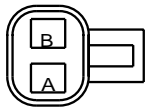
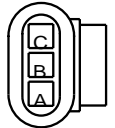

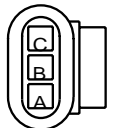

INTERNATIONAL TRUCK AND ENGINE CORPORATION				ELECTRICAL CIRCUIT DIAGRAM CHAPTER 14																																																																					
THIS PRINT IS PROVIDED ON A RESTRICTED BASIS AND IS NOT TO BE USED IN ANY WAY DETRIMENTAL TO THE INTEREST OF INTERNATIONAL TRUCK AND ENGINE CORPORATION.				CONNECTOR BODY COMPOSITE - MATING VIEW SHOWN																																																																					
SKIRT LIGHTING (8052) (LOCATED ON RIGHT SIDE DASH PANEL)  CONNECTOR 1667740C1 BODY LOCK 1667771C1				CUSTOMER SUPPLIES LIGHTS (8052) (W/ LONESTAR)  CONNECTOR 1671610C1 BODY LOCK 1671608C1																																																																					
<table border="1" style="width:100%; border-collapse: collapse; font-size: x-small;"> <thead> <tr> <th>CAV</th> <th>CIR</th> <th>GAUGE</th> <th>COLOR</th> <th>TERMINAL</th> <th>SEAL/SLEEVE</th> </tr> </thead> <tbody> <tr> <td>A</td> <td>A54-GXD</td> <td>16</td> <td>WH</td> <td>1667742C1</td> <td>1661872C1</td> </tr> <tr> <td>B</td> <td>A57B</td> <td>16</td> <td>OR</td> <td>1667742C1</td> <td>1661872C1</td> </tr> <tr> <td>C</td> <td>A54XC</td> <td>16</td> <td>BN</td> <td>1667742C1</td> <td>1661872C1</td> </tr> </tbody> </table>				CAV	CIR	GAUGE	COLOR	TERMINAL	SEAL/SLEEVE	A	A54-GXD	16	WH	1667742C1	1661872C1	B	A57B	16	OR	1667742C1	1661872C1	C	A54XC	16	BN	1667742C1	1661872C1	<table border="1" style="width:100%; border-collapse: collapse; font-size: x-small;"> <thead> <tr> <th>CAV</th> <th>CIR</th> <th>GAUGE</th> <th>COLOR</th> <th>TERMINAL</th> <th>SEAL/SLEEVE</th> </tr> </thead> <tbody> <tr> <td>A</td> <td>M54XC</td> <td>16</td> <td>OR</td> <td>2033819C1</td> <td>1652325C1</td> </tr> <tr> <td>B</td> <td>M54-GE</td> <td>16</td> <td>VT</td> <td>2033819C1</td> <td>1652325C1</td> </tr> </tbody> </table>				CAV	CIR	GAUGE	COLOR	TERMINAL	SEAL/SLEEVE	A	M54XC	16	OR	2033819C1	1652325C1	B	M54-GE	16	VT	2033819C1	1652325C1																								
CAV	CIR	GAUGE	COLOR	TERMINAL	SEAL/SLEEVE																																																																				
A	A54-GXD	16	WH	1667742C1	1661872C1																																																																				
B	A57B	16	OR	1667742C1	1661872C1																																																																				
C	A54XC	16	BN	1667742C1	1661872C1																																																																				
CAV	CIR	GAUGE	COLOR	TERMINAL	SEAL/SLEEVE																																																																				
A	M54XC	16	OR	2033819C1	1652325C1																																																																				
B	M54-GE	16	VT	2033819C1	1652325C1																																																																				
RIGHT TURN SIGNAL (8053) (LOCATED AT FORWARD END OF RIGHT FRAME RAIL)  CONNECTOR 1667741C1 BODY LOCK 1667771C1				LEFT MODESTY TURN LAMP (8100) (LOCATED AT FRONT OF LEFT SIDE MODESTY PANEL)  CONNECTOR 1667741C1 BODY LOCK 1667771C1																																																																					
<table border="1" style="width:100%; border-collapse: collapse; font-size: x-small;"> <thead> <tr> <th>CAV</th> <th>CIR</th> <th>GAUGE</th> <th>COLOR</th> <th>TERMINAL</th> <th>SEAL/SLEEVE</th> </tr> </thead> <tbody> <tr> <td>A</td> <td>A54-GXE</td> <td>16</td> <td>WH</td> <td>1661875C1</td> <td>1661872C1</td> </tr> <tr> <td>B</td> <td>A57A</td> <td>16</td> <td>OR</td> <td>1661875C1</td> <td>1661872C1</td> </tr> <tr> <td>C</td> <td>A54XB</td> <td>16</td> <td>BN</td> <td>1661875C1</td> <td>1661872C1</td> </tr> </tbody> </table>				CAV	CIR	GAUGE	COLOR	TERMINAL	SEAL/SLEEVE	A	A54-GXE	16	WH	1661875C1	1661872C1	B	A57A	16	OR	1661875C1	1661872C1	C	A54XB	16	BN	1661875C1	1661872C1	<table border="1" style="width:100%; border-collapse: collapse; font-size: x-small;"> <thead> <tr> <th>CAV</th> <th>CIR</th> <th>GAUGE</th> <th>COLOR</th> <th>TERMINAL</th> <th>SEAL/SLEEVE</th> </tr> </thead> <tbody> <tr> <td>A</td> <td>M11-GBB</td> <td>16</td> <td>WH</td> <td>1661875C1</td> <td>1661872C1</td> </tr> <tr> <td>A*</td> <td>M54-GDD</td> <td>16</td> <td>WH</td> <td>1661875C1</td> <td>1661872C1</td> </tr> <tr> <td>B</td> <td>M56AB</td> <td>16</td> <td>OR</td> <td>1661875C1</td> <td>1661872C1</td> </tr> <tr> <td>B*</td> <td>M56AF</td> <td>16</td> <td>OR</td> <td>1661875C1</td> <td>1661872C1</td> </tr> <tr> <td>C</td> <td>M58AB</td> <td>16</td> <td>BN</td> <td>1661875C1</td> <td>1661872C1</td> </tr> <tr> <td>C*</td> <td>M54A</td> <td>16</td> <td>BN</td> <td>1661875C1</td> <td>1661872C1</td> </tr> </tbody> </table> <p style="text-align: right; font-size: x-small;">* W/ LONESTAR</p>				CAV	CIR	GAUGE	COLOR	TERMINAL	SEAL/SLEEVE	A	M11-GBB	16	WH	1661875C1	1661872C1	A*	M54-GDD	16	WH	1661875C1	1661872C1	B	M56AB	16	OR	1661875C1	1661872C1	B*	M56AF	16	OR	1661875C1	1661872C1	C	M58AB	16	BN	1661875C1	1661872C1	C*	M54A	16	BN	1661875C1	1661872C1
CAV	CIR	GAUGE	COLOR	TERMINAL	SEAL/SLEEVE																																																																				
A	A54-GXE	16	WH	1661875C1	1661872C1																																																																				
B	A57A	16	OR	1661875C1	1661872C1																																																																				
C	A54XB	16	BN	1661875C1	1661872C1																																																																				
CAV	CIR	GAUGE	COLOR	TERMINAL	SEAL/SLEEVE																																																																				
A	M11-GBB	16	WH	1661875C1	1661872C1																																																																				
A*	M54-GDD	16	WH	1661875C1	1661872C1																																																																				
B	M56AB	16	OR	1661875C1	1661872C1																																																																				
B*	M56AF	16	OR	1661875C1	1661872C1																																																																				
C	M58AB	16	BN	1661875C1	1661872C1																																																																				
C*	M54A	16	BN	1661875C1	1661872C1																																																																				
LEFT FORWARD MODESTY PANEL TURN LIGHT (8100A) (LOCATED AT FRONT OF LEFT SIDE MODESTY PANEL) (W/ PROSTAR)  CONNECTOR 1667741C1 BODY LOCK 1667771C1				LEFT REAR MODESTY PANEL TURN LIGHT W/ SLEEPER (8100B)(OPTIONAL) (LOCATED AT LEFT SIDE MODESTY PANEL) (W/ PROSTAR)  CONNECTOR 1667741C1 BODY LOCK 1667771C1																																																																					
<table border="1" style="width:100%; border-collapse: collapse; font-size: x-small;"> <thead> <tr> <th>CAV</th> <th>CIR</th> <th>GAUGE</th> <th>COLOR</th> <th>TERMINAL</th> <th>SEAL/SLEEVE</th> </tr> </thead> <tbody> <tr> <td>A</td> <td>J11GBA</td> <td>16</td> <td>WH</td> <td>1661875C1</td> <td>1661872C1</td> </tr> <tr> <td>B</td> <td>J56AA</td> <td>16</td> <td>OR</td> <td>1661875C1</td> <td>1661872C1</td> </tr> <tr> <td>C</td> <td>J58AA</td> <td>16</td> <td>BN</td> <td>1661875C1</td> <td>1661872C1</td> </tr> </tbody> </table>				CAV	CIR	GAUGE	COLOR	TERMINAL	SEAL/SLEEVE	A	J11GBA	16	WH	1661875C1	1661872C1	B	J56AA	16	OR	1661875C1	1661872C1	C	J58AA	16	BN	1661875C1	1661872C1	<table border="1" style="width:100%; border-collapse: collapse; font-size: x-small;"> <thead> <tr> <th>CAV</th> <th>CIR</th> <th>GAUGE</th> <th>COLOR</th> <th>TERMINAL</th> <th>SEAL/SLEEVE</th> </tr> </thead> <tbody> <tr> <td>A</td> <td>J11GBB</td> <td>16</td> <td>WH</td> <td>1661875C1</td> <td>1661872C1</td> </tr> <tr> <td>B</td> <td>J56AB</td> <td>16</td> <td>OR</td> <td>1661875C1</td> <td>1661872C1</td> </tr> <tr> <td>C</td> <td>J58AB</td> <td>16</td> <td>BN</td> <td>1661875C1</td> <td>1661872C1</td> </tr> </tbody> </table>				CAV	CIR	GAUGE	COLOR	TERMINAL	SEAL/SLEEVE	A	J11GBB	16	WH	1661875C1	1661872C1	B	J56AB	16	OR	1661875C1	1661872C1	C	J58AB	16	BN	1661875C1	1661872C1																		
CAV	CIR	GAUGE	COLOR	TERMINAL	SEAL/SLEEVE																																																																				
A	J11GBA	16	WH	1661875C1	1661872C1																																																																				
B	J56AA	16	OR	1661875C1	1661872C1																																																																				
C	J58AA	16	BN	1661875C1	1661872C1																																																																				
CAV	CIR	GAUGE	COLOR	TERMINAL	SEAL/SLEEVE																																																																				
A	J11GBB	16	WH	1661875C1	1661872C1																																																																				
B	J56AB	16	OR	1661875C1	1661872C1																																																																				
C	J58AB	16	BN	1661875C1	1661872C1																																																																				
CHK	DATE	CHANGE	REV	REFERENCE	DRAWN	NAME																																																																			
CNA1	14JAN09	INITIAL RELEASE	A	61254R	300749	CIRCUIT DIAGRAM, PROSTAR, LONESTAR																																																																			
					RELEASE NO.	DATE																																																																			
					61254R	29AUG08																																																																			
					PART NO.	SHEET																																																																			
					AE08055906	93A																																																																			

Figure 355 Connector Composites (8052), (8053), (8100), (8100A), (8100B)

14.127. CONNECTOR COMPOSITES (8101), (8101A), (8101B), (8102), (8103), (8104), P. 94

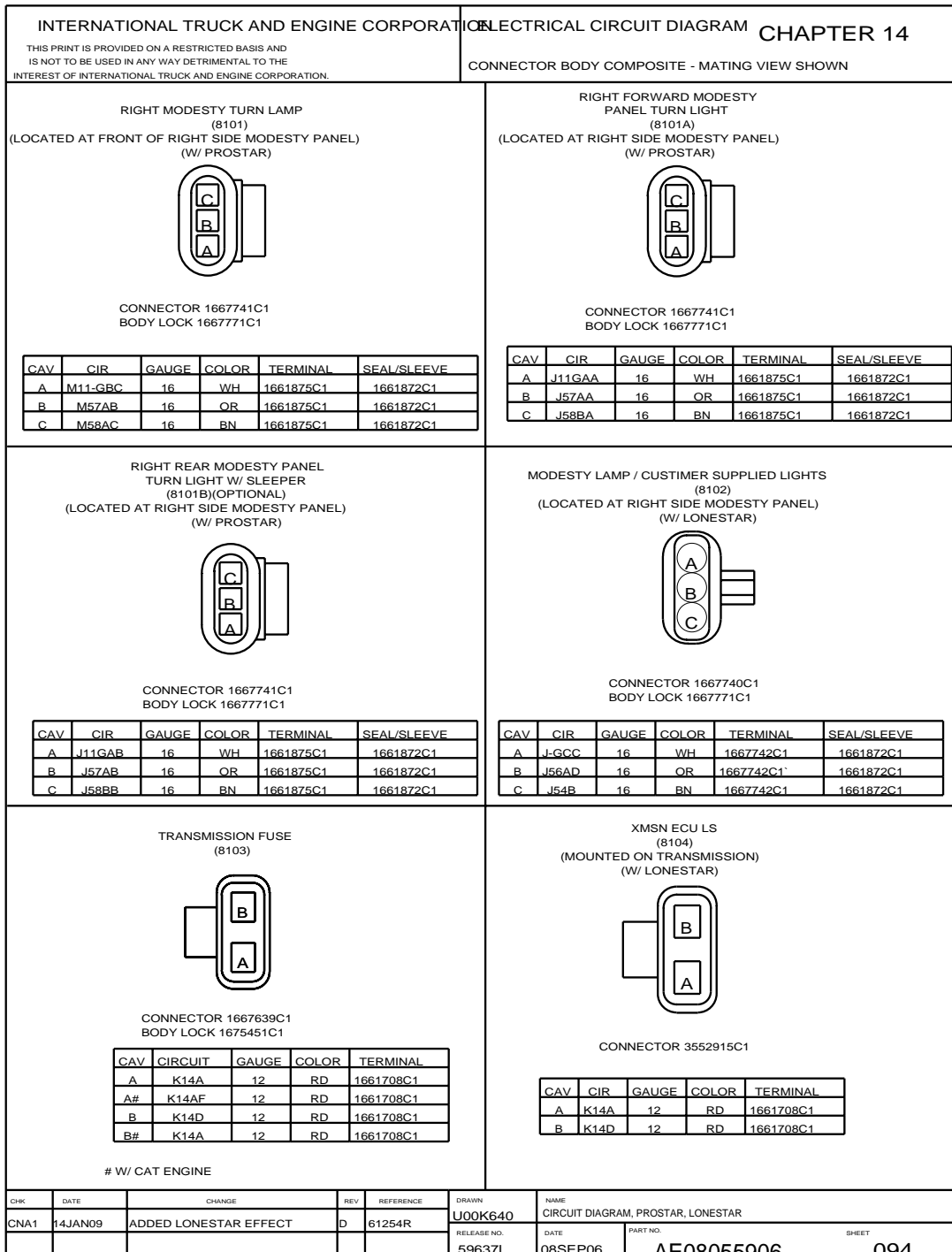


Figure 356 Connector Composites (8101), (8101A), (8101B), (8102), (8103), (8104)

14.128. CONNECTOR COMPOSITES (8165), (8166), (8166T), (8200), (8201), (8203), P. 95

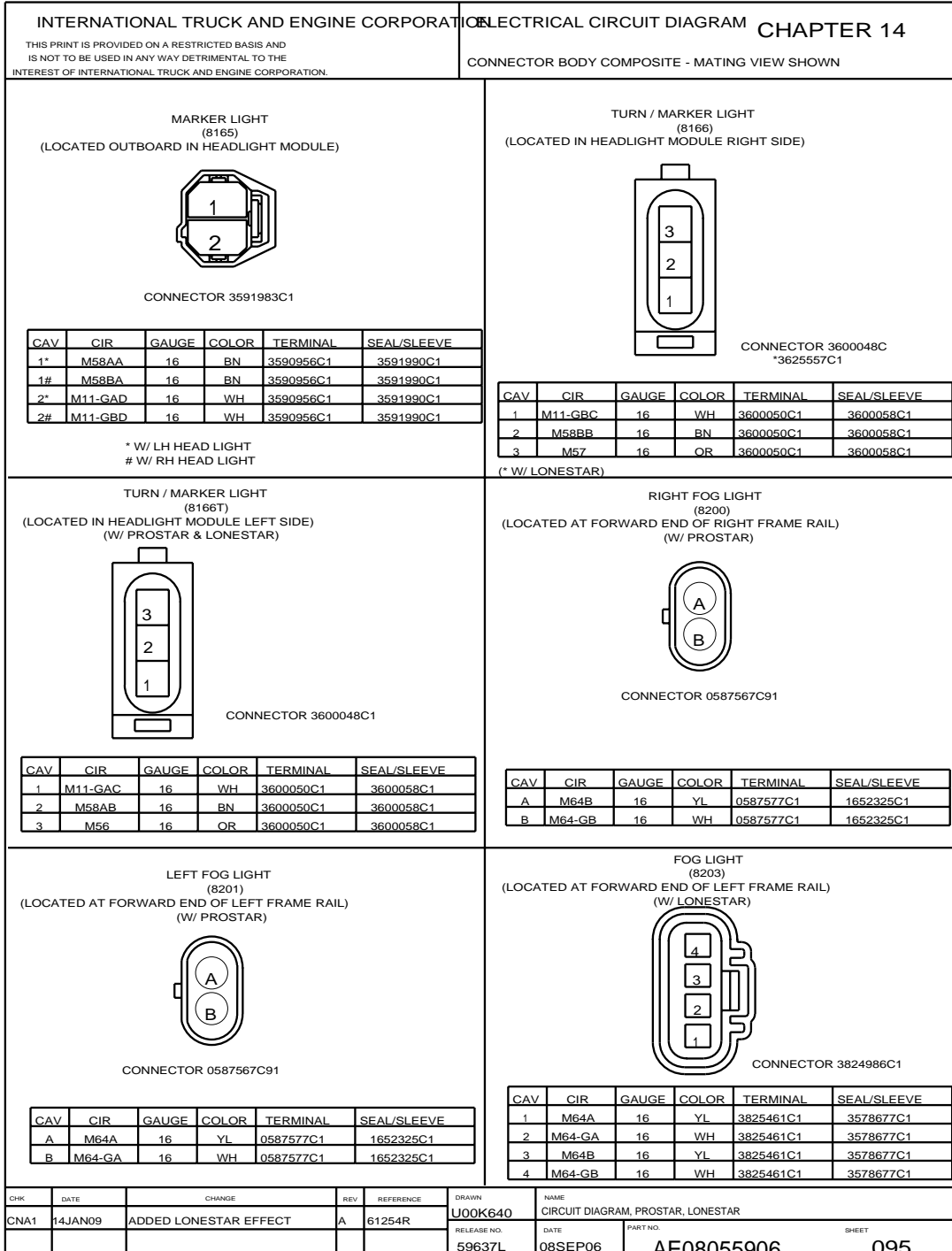


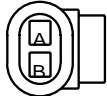
Figure 357 Connector Composites (8165), (8166), (8166T), (8200), (8201), (8203)

14.129. CONNECTOR COMPOSITES (8303), (8310), (8311), (8312), P. 96

INTERNATIONAL TRUCK AND ENGINE CORPORATION		ELECTRICAL CIRCUIT DIAGRAM CHAPTER 14			
THIS PRINT IS PROVIDED ON A RESTRICTED BASIS AND IS NOT TO BE USED IN ANY WAY DETRIMENTAL TO THE INTEREST OF INTERNATIONAL TRUCK AND ENGINE CORPORATION.		CONNECTOR BODY COMPOSITE - MATING VIEW SHOWN			

ELECTRIC HORN  
(8303)  
(LOCATED ON LEFT FRAME RAIL UNDER ENGINE CROSSMEMBER)  
(W/ PROSTAR & LONESTAR)

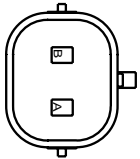


CAV	CIR	GAUGE	COLOR	TERMINAL	SEAL/SLEEVE
A	M85	16	GY	1661875C1	1661872C1
B	M85-GA	16	WH	1661875C1	1661872C1

CONNECTOR 1661778C1  
BODY LOCK 1661874C1

DUAL ELECTRIC HORNS  
(8310)  
(LOCATED ON LEFT FRAME RAIL UNDER ENGINE CROSSMEMBER)  
(W/ PROSTAR)

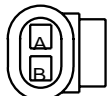


CAV	CIR	GAUGE	COLOR	TERMINAL	SEAL/SLEEVE
A	M85J	16	GY	1667742C1	1661872C1
B	M85-GC	16	WH	1667742C1	1661872C1

CONNECTOR 3543888C1  
BODY LOCK 1661874C1

ELECTRIC HORN # 1  
(8311)  
(LOCATED UNDER ENGINE CROSSMEMBER)  
(W/ PROSTAR)



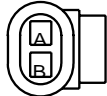
CAV	CIR	GAUGE	COLOR	TERMINAL	SEAL/SLEEVE
A*	M85J	16	GY	1661875C1	1661872C1
A**	M85K	16	GY	1661875C1	1661872C1
B*	M85-GC	16	WH	1661875C1	1661872C1
B**	M85-GD	16	WH	1661875C1	1661872C1

CONNECTOR 1661778C1  
BODY LOCK 1661874C1

\* W/ SINGLE HORN  
\*\* W/ DUAL HORN

ELECTRIC HORN # 2  
(8312)  
(LOCATED UNDER ENGINE CROSSMEMBER)  
(W/ PROSTAR)



CAV	CIR	GAUGE	COLOR	TERMINAL	SEAL/SLEEVE
A	M85L	16	GY	1661875C1	1661872C1
B	M85-GF	16	WH	1661875C1	1661872C1

CONNECTOR 1661778C1  
BODY LOCK 1661874C1

CHK	DATE	CHANGE	REV	REFERENCE	DRAWN	NAME
CNA1	20JAN09	TITLE WAS CIRCUIT	B	61254R	U00K640	CIRCUIT DIAGRAM, PROSTAR, LONESTAR
		DIAGRAM, PROSTAR			59637L	08SEP06
						AE08055906
						096

Figure 358 Connector Composites (8303), (8310), (8311), (8312)

14.130. CONNECTOR COMPOSITES (8350), (8351), (8352), (8410), (8450), P. 97

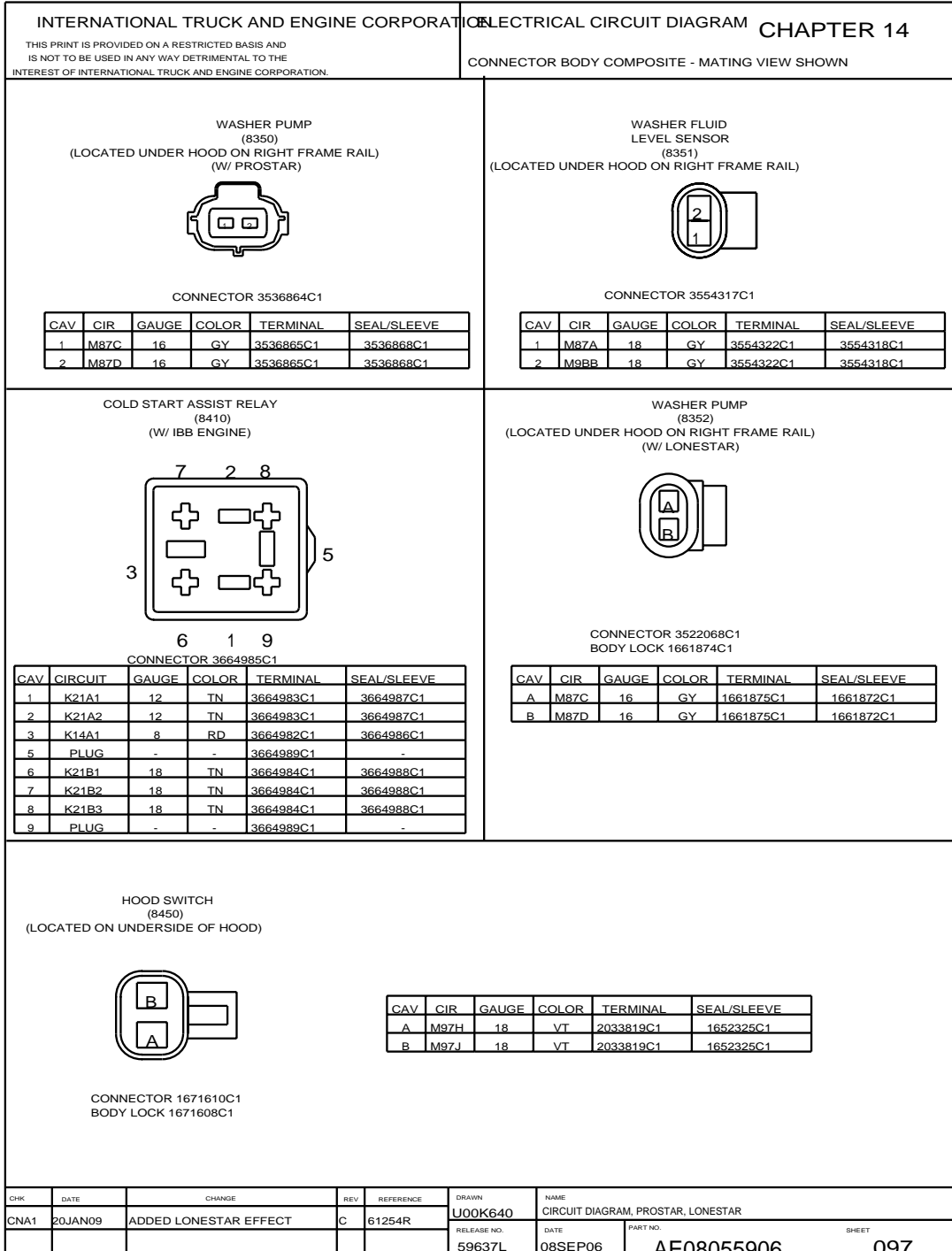


Figure 359 Connector Composites (8350), (8351), (8352), (8410), (8450)

14.131. CONNECTOR COMPOSITES (8450A), (8450B), (8451), (8453), (8454), (8455), (8456), (8500), P. 98

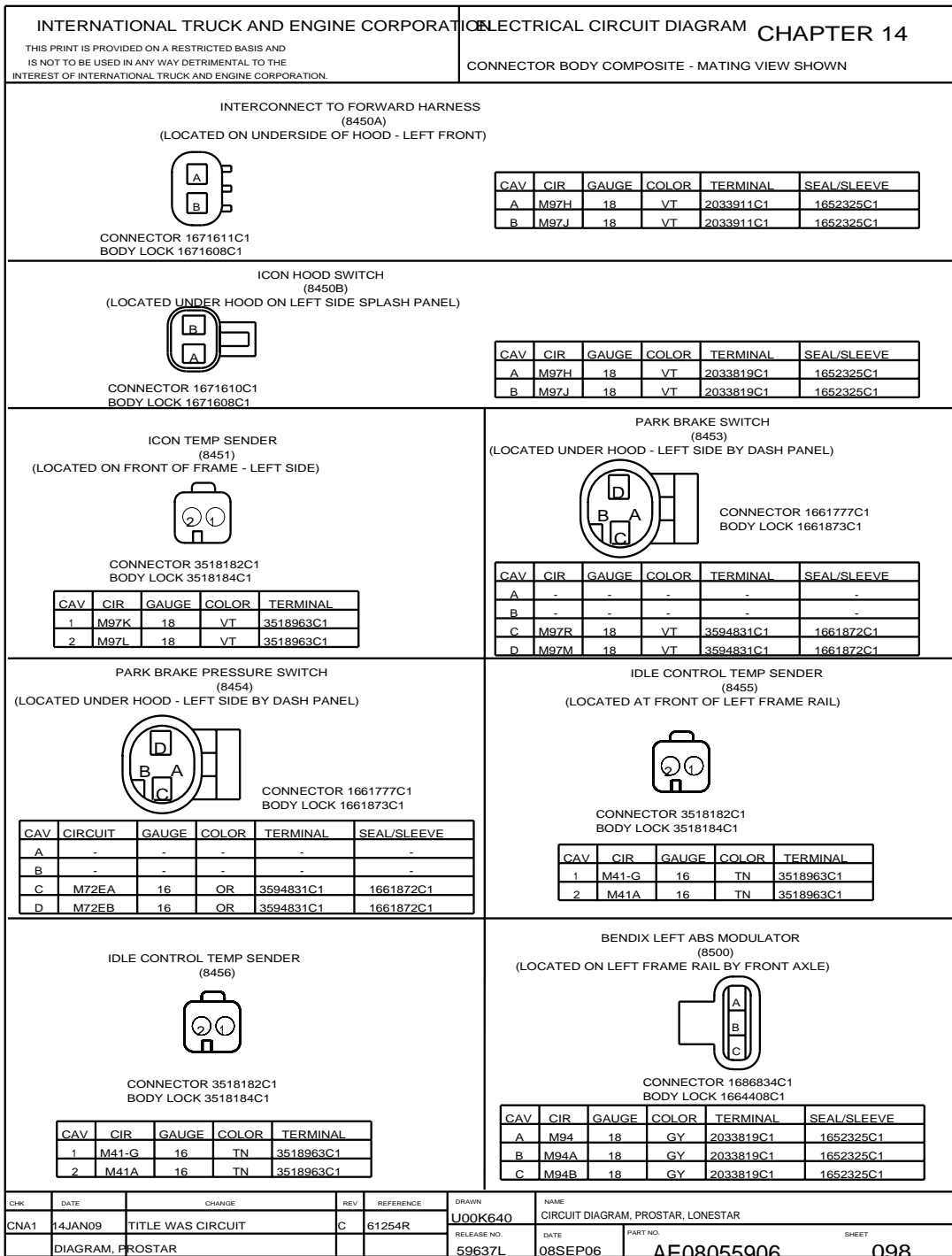


Figure 360 Connector Composites (8450A), (8450B), (8451), (8453), (8454), (8455), (8456), (8500)

14.132. CONNECTOR COMPOSITES (8501), (8502), (8503), (8504), P. 99

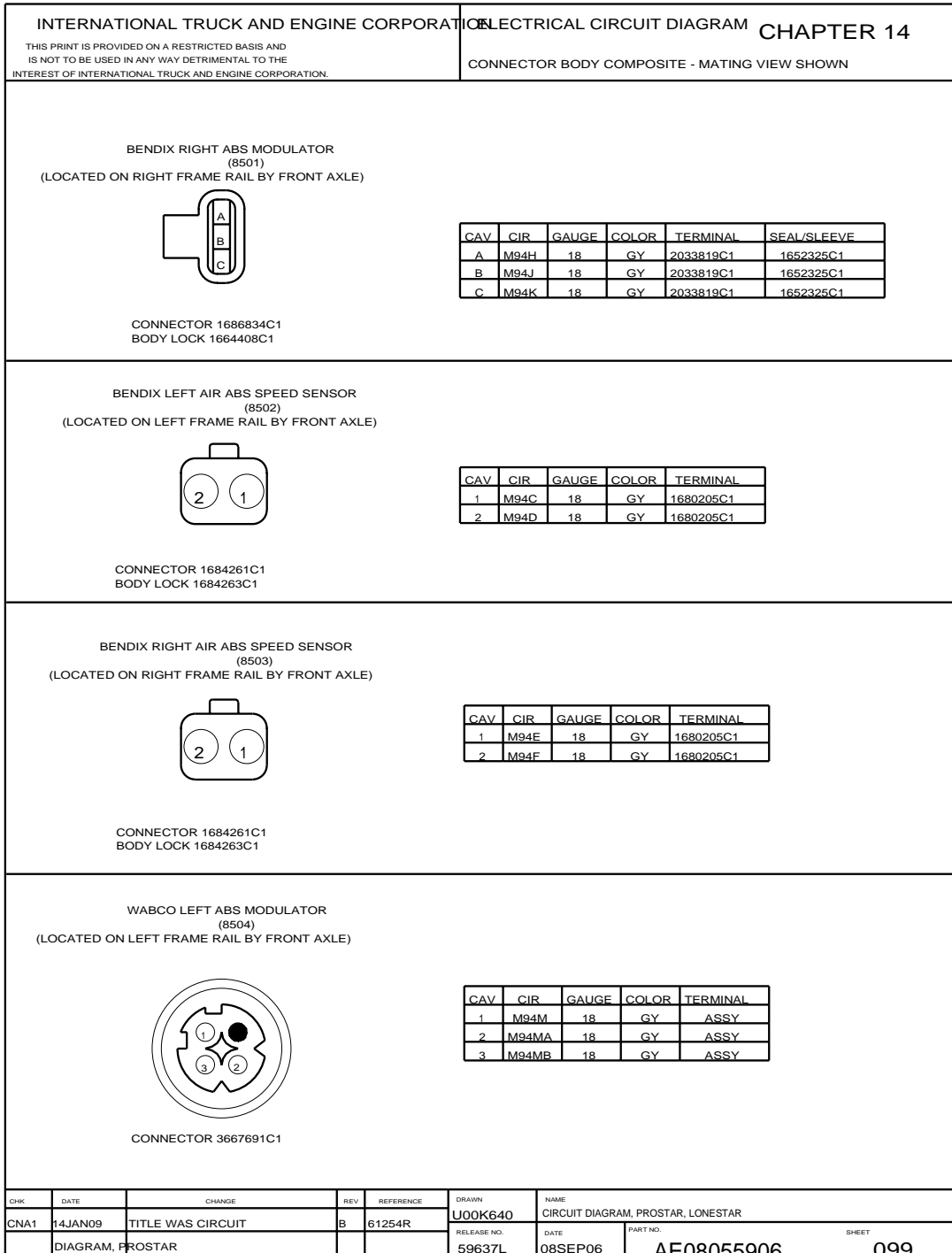


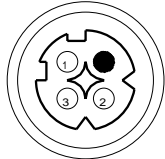
Figure 361 Connector Composites (8501), (8502), (8503), (8504)

14.133. CONNECTOR COMPOSITES (8505), (8506), (8507), (8550), P. 100

INTERNATIONAL TRUCK AND ENGINE CORPORATION		ELECTRICAL CIRCUIT DIAGRAM		CHAPTER 14	
THIS PRINT IS PROVIDED ON A RESTRICTED BASIS AND IS NOT TO BE USED IN ANY WAY DETRIMENTAL TO THE INTEREST OF INTERNATIONAL TRUCK AND ENGINE CORPORATION.		CONNECTOR BODY COMPOSITE - MATING VIEW SHOWN			

WABCO RIGHT ABS MODULATOR  
(8505)  
(LOCATED ON RIGHT FRAME RAIL BY FRONT AXLE)




CAV	CIR	GAUGE	COLOR	TERMINAL
1	M94MH	18	GY	ASSY
2	M94MJ	18	GY	ASSY
3	M94MK	18	GY	ASSY

CONNECTOR 366769C1

WABCO LEFT ABS SPEED SENSOR  
(8506)  
(LOCATED ON LEFT FRAME RAIL BY FRONT AXLE)

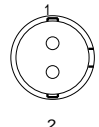


CAV	CIR	GAUGE	COLOR	TERMINAL
1	M94MC	18	GY	ASSY
2	M94MD	18	GY	ASSY

CONNECTOR 3519878C1

WABCO RIGHT ABS SPEED SENSOR  
(8507)  
(LOCATED ON ROGHT FRAME RAIL BY FRONT AXLE)

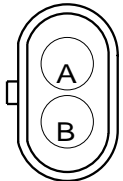


CAV	CIR	GAUGE	COLOR	TERMINAL
1	M94ME	18	GY	ASSY
2	M94MF	18	GY	ASSY

CONNECTOR 3526351C1

FUEL HEATER  
(8550)  
(LOCATED ON LEFT FRAME RAIL ON FUEL FILTER)



CAV	CIR	GAUGE	COLOR	TERMINAL	SEAL/SLEEVE
A	M19	14	GY	0587577C1	0589391C1
B	M19-GA	14	WH	0587577C1	0589391C1

CONNECTOR 0587567C91  
#CONNECTOR 3824963C91

# W/ LONESTAR

CHK	DATE	CHANGE	REV	REFERENCE	DRAWN	NAME
CNA1	14JAN09	ADDED LONESTAR EFFECT	B	61254R	U00K640	CIRCUIT DIAGRAM, PROSTAR, LONESTAR
					RELEASE NO. 59637L	DATE 08SEP06
						PART NO. AE08055906
						SHEET 100

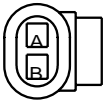
Figure 362 Connector Composites (8505), (8506), (8507), (8550)

14.134. CONNECTOR COMPOSITES (8601), (8750), (8800), (8802), P. 101

INTERNATIONAL TRUCK AND ENGINE CORPORATION				ELECTRICAL CIRCUIT DIAGRAM		CHAPTER 14	
THIS PRINT IS PROVIDED ON A RESTRICTED BASIS AND IS NOT TO BE USED IN ANY WAY DETRIMENTAL TO THE INTEREST OF INTERNATIONAL TRUCK AND ENGINE CORPORATION.				CONNECTOR BODY COMPOSITE - MATING VIEW SHOWN			

HVAC TEMP SENDER  
(8601)  
(LOCATED AT FRONT OF LEFT FRAME RAIL)



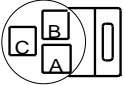
CAV	CIR	GAUGE	COLOR	TERMINAL	SEAL/SLEEVE
A	M41	18	GY	1661875C1	1661872C1
B	M109A	18	GY	1661875C1	1661872C1
B*	M109AA	18	GY	1661875C1	1661872C1

CONNECTOR 3522068C1  
BODY LOCK 1661874C1

\* W/ FRONT LOAD INDICATOR

FRONT LOAD INDICATOR  
(8750)  
(LOCATED AT FRONT LEFT SUSPENSION AIR BAG)

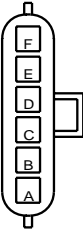


CAV	CIR	GAUGE	COLOR	TERMINAL
A	M109AB	18	GY	1651943C1
B	M106A	18	GY	1651943C1
C	M61	18	GY	1651943C1

CONNECTOR 1678137C1

GROUND SPLICE PACK # 1  
(8800)  
(LOCATED ON LEFT FRAME RAIL BY ENGINE CROSSMEMBER)

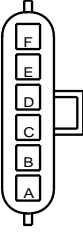


CAV	CIR	GAUGE	COLOR	TERMINAL	SEAL/SLEEVE
A	M11-GD	12	WH	2033816C1	0589390C1
B	M64-GA	16	WH	2033819C1	1652325C1
C	M64-GB	16	WH	2033819C1	1652325C1
D	M19-GA	14	WH	2033816C1	0589391C1
E	M54-GA	16	WH	2033819C1	1652325C1
F	M85-GA	16	WH	2033819C1	1652325C1

CONNECTOR 3551896C1  
BODY LOCK 3551897C1

ELECTRONIC GND SPLICE PACK  
(8802)  
(LOCATED ON LEFT FRAME RAIL UNDER CAB)



CAV	CIR	GAUGE	COLOR	TERMINAL	SEAL/SLEEVE
A	N9BC	18	GY	2033819C1	1652325C1
B	N9BD	18	GY	2033819C1	1652325C1
C	N9BE	18	GY	2033819C1	1652325C1
D	N9BF	18	GY	2033819C1	1652325C1
E	PLUG	-	-	0587579C1	-
F	PLUG	-	-	0587579C1	-

CONNECTOR 3551896C1  
BODY LOCK 3551897C1

CHK	DATE	CHANGE	REV	REFERENCE	DRAWN	NAME
CNA1	14JAN09	TITLE WAS CIRCUIT	A	61254R	U00K640	CIRCUIT DIAGRAM, PROSTAR, LONESTAR
		DIAGRAM, PROSTAR			59637L	
					11SEP06	AE08055906
						101

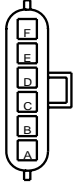
Figure 363 Connector Composites (8601), (8750), (8800), (8802)

14.135. CONNECTOR COMPOSITES (8803), (8804), (8805), (8806), P. 102

INTERNATIONAL TRUCK AND ENGINE CORPORATION		ELECTRICAL CIRCUIT DIAGRAM		CHAPTER 14	
THIS PRINT IS PROVIDED ON A RESTRICTED BASIS AND IS NOT TO BE USED IN ANY WAY DETRIMENTAL TO THE INTEREST OF INTERNATIONAL TRUCK AND ENGINE CORPORATION.		CONNECTOR BODY COMPOSITE - MATING VIEW SHOWN			

CHASSIS GND ADAPTER  
(8803)  
(LOCATED ON LEFT FRAME RAIL UNDER CAB)

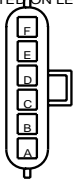


CAV	CIR	GAUGE	COLOR	TERMINAL	SEAL/SLEEVE
A	N11-GA	10	WH	1687847C1	0589390C1
B	N10-G	12	WH	2033816C1	0589391C1
C	N59-GB	16	WH	2033819C1	1652325C1
D	N37-G	18	WH	2033819C1	1652325C1
E	N39-G	16	WH	2033819C1	1652325C1
F	N11-GJ	16	WH	2033819C1	1652325C1

CONNECTOR 3551896C1  
BODY LOCK 3551897C1

CHASSIS GND ADAPTER  
(8804)  
(LOCATED ON LEFT FRAME RAIL UNDER CAB)

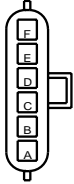


CAV	CIR	GAUGE	COLOR	TERMINAL	SEAL/SLEEVE
A	N11-GB	10	WH	1687847C1	0589390C1
B	N59-G	14	WH	2033816C1	0589391C1
C	N59-GA	14	WH	2033816C1	0589391C1
D	N49-G	18	WH	2033819C1	1652325C1
E	N65-G	16	WH	2033819C1	1652325C1
F	N65-GA	14	WH	2033816C1	0589391C1

CONNECTOR 3551896C1  
BODY LOCK 3551897C1

ELECTRONIC GROUND ADAPTER  
(8805)  
(LOCATED ON CENTRE CHASSIS HARNESS, BOTTOM OF DASH PANEL)

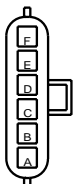


CAV	CIR	GAUGE	COLOR	TERMINAL	SEAL/SLEEVE
A	N110Z	16	TN	2033819C1	1652325C1
B	N108ZA	16	TN	2033819C1	1652325C1
C	N108ZB	16	TN	2033819C1	1652325C1
D	N108Z	16	TN	2033819C1	1652325C1
E	PLUG	-	-	0587579C1	-
F	PLUG	-	-	0587579C1	-

CONNECTOR 3551896C1  
BODY LOCK 3551897C1

CHASSIS GROUND ADAPTER  
(8806)  
(LOCATED ON LEFT FRAME RAIL BY AIR DRYER)



CAV	CIR	GAUGE	COLOR	TERMINAL	SEAL/SLEEVE
A	N107-GB	18	TN	2033819C1	3517771C1
B	N107-GA	18	TN	2033819C1	1652325C1
C	N107-GC	18	TN	2033819C1	1652325C1
D	N11-GU	16	WH	2033819C1	1652325C1
E	N11-GJ	16	WH	2033819C1	1652325C1
F	PLUG	-	-	0587579C1	-

CONNECTOR 3551896C1  
BODY LOCK 3551897C1

CHK	DATE	CHANGE	REV	REFERENCE	DRAWN	NAME
CNA1	14JAN09	TITLE WAS CIRCUIT	B	61254R	U00K640	CIRCUIT DIAGRAM, PROSTAR, LONESTAR
		DIAGRAM, PROSTAR			59637L	11SEP06
						AE08055906
						102

Figure 364 Connector Composites (8803), (8804), (8805), (8806)

14.136. CONNECTOR COMPOSITES (8900), (8901), (8902), (8950), (8951), P. 103

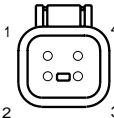

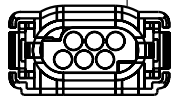
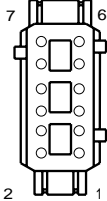
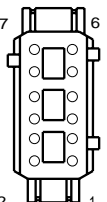
INTERNATIONAL TRUCK AND ENGINE CORPORATION				ELECTRICAL CIRCUIT DIAGRAM CHAPTER 14																																																																																																																																													
THIS PRINT IS PROVIDED ON A RESTRICTED BASIS AND IS NOT TO BE USED IN ANY WAY DETRIMENTAL TO THE INTEREST OF INTERNATIONAL TRUCK AND ENGINE CORPORATION.				CONNECTOR BODY COMPOSITE - MATING VIEW SHOWN																																																																																																																																													
 <p>EATON VORAD ANTENNA ASSEMBLY (8900) (LOCATED CENTER OF BUMPER SUPPORT BRACKET) (W/ PROSTAR)</p> <p>CONNECTOR 3545577C1 BODY LOCK 3545579C1</p> <table border="1" style="width:100%; border-collapse: collapse; font-size: x-small;"> <thead> <tr> <th>CAV</th> <th>CIR</th> <th>GAUGE</th> <th>COLOR</th> <th>TERMINAL</th> </tr> </thead> <tbody> <tr><td>1</td><td>M67B</td><td>16</td><td>GY</td><td>1651969C1</td></tr> <tr><td>2</td><td>M67C</td><td>16</td><td>GY</td><td>1651969C1</td></tr> <tr><td>3</td><td>M67D</td><td>16</td><td>GY</td><td>1651969C1</td></tr> <tr><td>4</td><td>M67E</td><td>16</td><td>GY</td><td>1651969C1</td></tr> </tbody> </table>				CAV	CIR	GAUGE	COLOR	TERMINAL	1	M67B	16	GY	1651969C1	2	M67C	16	GY	1651969C1	3	M67D	16	GY	1651969C1	4	M67E	16	GY	1651969C1	 <p>EATON VORAD VS - 400 (8901) (LOCATED CENTER OF BUMPER SUPPORT BRACKET)</p> <p>CONNECTOR 3673402C1</p> <table border="1" style="width:100%; border-collapse: collapse; font-size: x-small;"> <thead> <tr> <th>CAV</th> <th>CIR</th> <th>GAUGE</th> <th>COLOR</th> <th>TERMINAL</th> <th>SEAL/SLEEVE</th> </tr> </thead> <tbody> <tr><td>1</td><td>PLUG</td><td>-</td><td>-</td><td>3577744C1</td><td>-</td></tr> <tr><td>2</td><td>PLUG</td><td>-</td><td>-</td><td>3577744C1</td><td>-</td></tr> <tr><td>3</td><td>PLUG</td><td>-</td><td>-</td><td>3577744C1</td><td>-</td></tr> <tr><td>4</td><td>M5UE(+)</td><td>18</td><td>YL</td><td>3673404C1</td><td>3573653C1</td></tr> <tr><td>5</td><td>M5UE(-)</td><td>18</td><td>GN</td><td>3673404C1</td><td>3573653C1</td></tr> <tr><td>6</td><td>PLUG</td><td>-</td><td>-</td><td>3577744C1</td><td>-</td></tr> <tr><td>7</td><td>PLUG</td><td>-</td><td>-</td><td>3577744C1</td><td>-</td></tr> <tr><td>8</td><td>PLUG</td><td>-</td><td>-</td><td>3577744C1</td><td>-</td></tr> <tr><td>9</td><td>M67-GY</td><td>18</td><td>WH</td><td>3673404C1</td><td>3573653C1</td></tr> <tr><td>10</td><td>M67Y</td><td>18</td><td>PK</td><td>3673404C1</td><td>3573653C1</td></tr> </tbody> </table>				CAV	CIR	GAUGE	COLOR	TERMINAL	SEAL/SLEEVE	1	PLUG	-	-	3577744C1	-	2	PLUG	-	-	3577744C1	-	3	PLUG	-	-	3577744C1	-	4	M5UE(+)	18	YL	3673404C1	3573653C1	5	M5UE(-)	18	GN	3673404C1	3573653C1	6	PLUG	-	-	3577744C1	-	7	PLUG	-	-	3577744C1	-	8	PLUG	-	-	3577744C1	-	9	M67-GY	18	WH	3673404C1	3573653C1	10	M67Y	18	PK	3673404C1	3573653C1																																															
CAV	CIR	GAUGE	COLOR	TERMINAL																																																																																																																																													
1	M67B	16	GY	1651969C1																																																																																																																																													
2	M67C	16	GY	1651969C1																																																																																																																																													
3	M67D	16	GY	1651969C1																																																																																																																																													
4	M67E	16	GY	1651969C1																																																																																																																																													
CAV	CIR	GAUGE	COLOR	TERMINAL	SEAL/SLEEVE																																																																																																																																												
1	PLUG	-	-	3577744C1	-																																																																																																																																												
2	PLUG	-	-	3577744C1	-																																																																																																																																												
3	PLUG	-	-	3577744C1	-																																																																																																																																												
4	M5UE(+)	18	YL	3673404C1	3573653C1																																																																																																																																												
5	M5UE(-)	18	GN	3673404C1	3573653C1																																																																																																																																												
6	PLUG	-	-	3577744C1	-																																																																																																																																												
7	PLUG	-	-	3577744C1	-																																																																																																																																												
8	PLUG	-	-	3577744C1	-																																																																																																																																												
9	M67-GY	18	WH	3673404C1	3573653C1																																																																																																																																												
10	M67Y	18	PK	3673404C1	3573653C1																																																																																																																																												
 <p>WABCO ONGUARD (8902) (LOCATED CENTER OF BUMPER SUPPORT BRACKET)</p> <p>CONNECTOR 3702847C1</p> <table border="1" style="width:100%; border-collapse: collapse; font-size: x-small;"> <thead> <tr> <th>CAV</th> <th>CIR</th> <th>GAUGE</th> <th>COLOR</th> <th>TERMINAL</th> <th>SEAL/SLEEVE</th> </tr> </thead> <tbody> <tr><td>1</td><td>M67CA</td><td>20</td><td>PK</td><td>3702881C1</td><td>3600327C1</td></tr> <tr><td>2</td><td>PLUG</td><td>-</td><td>-</td><td>3600328C1</td><td>-</td></tr> <tr><td>3</td><td>PLUG</td><td>-</td><td>-</td><td>3600328C1</td><td>-</td></tr> <tr><td>4</td><td>M5UF(+)</td><td>20</td><td>YL</td><td>3702881C1</td><td>3600327C1</td></tr> <tr><td>5</td><td>M5UF(-)</td><td>20</td><td>GN</td><td>3702881C1</td><td>3600327C1</td></tr> <tr><td>6</td><td>M67Y-GA</td><td>20</td><td>WH</td><td>3702881C1</td><td>3600327C1</td></tr> </tbody> </table>				CAV	CIR	GAUGE	COLOR	TERMINAL	SEAL/SLEEVE	1	M67CA	20	PK	3702881C1	3600327C1	2	PLUG	-	-	3600328C1	-	3	PLUG	-	-	3600328C1	-	4	M5UF(+)	20	YL	3702881C1	3600327C1	5	M5UF(-)	20	GN	3702881C1	3600327C1	6	M67Y-GA	20	WH	3702881C1	3600327C1	<table border="1" style="width:100%; border-collapse: collapse; font-size: x-small;"> <thead> <tr> <th>CAV</th> <th>CIR</th> <th>GAUGE</th> <th>COLOR</th> <th>TERMINAL</th> <th>SEAL/SLEEVE</th> </tr> </thead> <tbody> <tr><td>1</td><td>PLUG</td><td>-</td><td>-</td><td>3527276C1</td><td>-</td></tr> <tr><td>2</td><td>PLUG</td><td>-</td><td>-</td><td>3527276C1</td><td>-</td></tr> <tr><td>3</td><td>PLUG</td><td>-</td><td>-</td><td>3527276C1</td><td>-</td></tr> <tr><td>4</td><td>PLUG</td><td>-</td><td>-</td><td>3527276C1</td><td>-</td></tr> <tr><td>5</td><td>N5UA(+)</td><td>18</td><td>YL</td><td>3518963C1</td><td>-</td></tr> <tr><td>5*</td><td>N5UD(+)</td><td>18</td><td>YL</td><td>3518963C1</td><td>-</td></tr> <tr><td>6</td><td>N5UA(-)</td><td>18</td><td>GN</td><td>3518963C1</td><td>-</td></tr> <tr><td>6*</td><td>N5UD(-)</td><td>18</td><td>GN</td><td>3518963C1</td><td>-</td></tr> <tr><td>7</td><td>N11-GU</td><td>16</td><td>WH</td><td>3518963C1</td><td>-</td></tr> <tr><td>8</td><td>N14U</td><td>16</td><td>RD</td><td>3518963C1</td><td>-</td></tr> <tr><td>9**</td><td>N12UB</td><td>16</td><td>PK</td><td>3518963C1</td><td>-</td></tr> <tr><td>9</td><td>N12U</td><td>16</td><td>PK</td><td>3518963C1</td><td>-</td></tr> <tr><td>10</td><td>N108Z</td><td>16</td><td>TN</td><td>3518963C1</td><td>-</td></tr> <tr><td>11</td><td>N108V</td><td>16</td><td>TN</td><td>3518963C1</td><td>-</td></tr> <tr><td>12</td><td>N110B</td><td>18</td><td>TN</td><td>3518963C1</td><td>-</td></tr> </tbody> </table>				CAV	CIR	GAUGE	COLOR	TERMINAL	SEAL/SLEEVE	1	PLUG	-	-	3527276C1	-	2	PLUG	-	-	3527276C1	-	3	PLUG	-	-	3527276C1	-	4	PLUG	-	-	3527276C1	-	5	N5UA(+)	18	YL	3518963C1	-	5*	N5UD(+)	18	YL	3518963C1	-	6	N5UA(-)	18	GN	3518963C1	-	6*	N5UD(-)	18	GN	3518963C1	-	7	N11-GU	16	WH	3518963C1	-	8	N14U	16	RD	3518963C1	-	9**	N12UB	16	PK	3518963C1	-	9	N12U	16	PK	3518963C1	-	10	N108Z	16	TN	3518963C1	-	11	N108V	16	TN	3518963C1	-	12	N110B	18	TN	3518963C1	-
CAV	CIR	GAUGE	COLOR	TERMINAL	SEAL/SLEEVE																																																																																																																																												
1	M67CA	20	PK	3702881C1	3600327C1																																																																																																																																												
2	PLUG	-	-	3600328C1	-																																																																																																																																												
3	PLUG	-	-	3600328C1	-																																																																																																																																												
4	M5UF(+)	20	YL	3702881C1	3600327C1																																																																																																																																												
5	M5UF(-)	20	GN	3702881C1	3600327C1																																																																																																																																												
6	M67Y-GA	20	WH	3702881C1	3600327C1																																																																																																																																												
CAV	CIR	GAUGE	COLOR	TERMINAL	SEAL/SLEEVE																																																																																																																																												
1	PLUG	-	-	3527276C1	-																																																																																																																																												
2	PLUG	-	-	3527276C1	-																																																																																																																																												
3	PLUG	-	-	3527276C1	-																																																																																																																																												
4	PLUG	-	-	3527276C1	-																																																																																																																																												
5	N5UA(+)	18	YL	3518963C1	-																																																																																																																																												
5*	N5UD(+)	18	YL	3518963C1	-																																																																																																																																												
6	N5UA(-)	18	GN	3518963C1	-																																																																																																																																												
6*	N5UD(-)	18	GN	3518963C1	-																																																																																																																																												
7	N11-GU	16	WH	3518963C1	-																																																																																																																																												
8	N14U	16	RD	3518963C1	-																																																																																																																																												
9**	N12UB	16	PK	3518963C1	-																																																																																																																																												
9	N12U	16	PK	3518963C1	-																																																																																																																																												
10	N108Z	16	TN	3518963C1	-																																																																																																																																												
11	N108V	16	TN	3518963C1	-																																																																																																																																												
12	N110B	18	TN	3518963C1	-																																																																																																																																												
 <p>VEHICLE SENSOR MOD CONNECTOR 1 (8950) (LOCATED ON CAB SUPPORT CROSSMEMBER (DAY CAB) OR UNDER CAB CROSSMEMBER (SLEEPER))</p> <p>CONNECTOR 3553404C1 BODY LOCK 3553460C1</p> <p style="font-size: x-small;">* w/ VORAD VS-400 (TG) ** w/ FUEL FILTER SENSOR (TG)</p>				<table border="1" style="width:100%; border-collapse: collapse; font-size: x-small;"> <thead> <tr> <th>CAV</th> <th>CIR</th> <th>GAUGE</th> <th>COLOR</th> <th>TERMINAL</th> </tr> </thead> <tbody> <tr><td>1</td><td>N107C</td><td>18</td><td>TN</td><td>3518963C1</td></tr> <tr><td>2</td><td>N107B</td><td>18</td><td>TN</td><td>3518963C1</td></tr> <tr><td>3</td><td>N107A</td><td>18</td><td>TN</td><td>3518963C1</td></tr> <tr><td>4</td><td>PLUG</td><td>-</td><td>-</td><td>3527276C1</td></tr> <tr><td>5</td><td>N108A</td><td>18</td><td>TN</td><td>3518963C1</td></tr> <tr><td>6</td><td>N108B</td><td>18</td><td>TN</td><td>3518963C1</td></tr> <tr><td>7</td><td>N108C</td><td>18</td><td>TN</td><td>3518963C1</td></tr> <tr><td>8</td><td>N108D</td><td>18</td><td>TN</td><td>3518963C1</td></tr> <tr><td>9</td><td>N108E</td><td>18</td><td>TN</td><td>3518963C1</td></tr> <tr><td>10</td><td>N108F</td><td>18</td><td>TN</td><td>3518963C1</td></tr> <tr><td>11</td><td>PLUG</td><td>-</td><td>-</td><td>3527276C1</td></tr> <tr><td>12</td><td>PLUG</td><td>-</td><td>-</td><td>3527276C1</td></tr> </tbody> </table>				CAV	CIR	GAUGE	COLOR	TERMINAL	1	N107C	18	TN	3518963C1	2	N107B	18	TN	3518963C1	3	N107A	18	TN	3518963C1	4	PLUG	-	-	3527276C1	5	N108A	18	TN	3518963C1	6	N108B	18	TN	3518963C1	7	N108C	18	TN	3518963C1	8	N108D	18	TN	3518963C1	9	N108E	18	TN	3518963C1	10	N108F	18	TN	3518963C1	11	PLUG	-	-	3527276C1	12	PLUG	-	-	3527276C1																																																																									
CAV	CIR	GAUGE	COLOR	TERMINAL																																																																																																																																													
1	N107C	18	TN	3518963C1																																																																																																																																													
2	N107B	18	TN	3518963C1																																																																																																																																													
3	N107A	18	TN	3518963C1																																																																																																																																													
4	PLUG	-	-	3527276C1																																																																																																																																													
5	N108A	18	TN	3518963C1																																																																																																																																													
6	N108B	18	TN	3518963C1																																																																																																																																													
7	N108C	18	TN	3518963C1																																																																																																																																													
8	N108D	18	TN	3518963C1																																																																																																																																													
9	N108E	18	TN	3518963C1																																																																																																																																													
10	N108F	18	TN	3518963C1																																																																																																																																													
11	PLUG	-	-	3527276C1																																																																																																																																													
12	PLUG	-	-	3527276C1																																																																																																																																													
 <p>VEHICLE SENSOR MOD CONNECTOR 1 (8951) (LOCATED ON CAB SUPPORT CROSSMEMBER (DAY CAB) OR UNDER CAB CROSSMEMBER (SLEEPER))</p> <p>CONNECTOR 3586750C1 BODY LOCK 3553460C1</p>				<table border="1" style="width:100%; border-collapse: collapse; font-size: x-small;"> <thead> <tr> <th>CAV</th> <th>CIR</th> <th>GAUGE</th> <th>COLOR</th> <th>TERMINAL</th> </tr> </thead> <tbody> <tr><td>1</td><td>N107C</td><td>18</td><td>TN</td><td>3518963C1</td></tr> <tr><td>2</td><td>N107B</td><td>18</td><td>TN</td><td>3518963C1</td></tr> <tr><td>3</td><td>N107A</td><td>18</td><td>TN</td><td>3518963C1</td></tr> <tr><td>4</td><td>PLUG</td><td>-</td><td>-</td><td>3527276C1</td></tr> <tr><td>5</td><td>N108A</td><td>18</td><td>TN</td><td>3518963C1</td></tr> <tr><td>6</td><td>N108B</td><td>18</td><td>TN</td><td>3518963C1</td></tr> <tr><td>7</td><td>N108C</td><td>18</td><td>TN</td><td>3518963C1</td></tr> <tr><td>8</td><td>N108D</td><td>18</td><td>TN</td><td>3518963C1</td></tr> <tr><td>9</td><td>N108E</td><td>18</td><td>TN</td><td>3518963C1</td></tr> <tr><td>10</td><td>N108F</td><td>18</td><td>TN</td><td>3518963C1</td></tr> <tr><td>11</td><td>PLUG</td><td>-</td><td>-</td><td>3527276C1</td></tr> <tr><td>12</td><td>PLUG</td><td>-</td><td>-</td><td>3527276C1</td></tr> </tbody> </table>				CAV	CIR	GAUGE	COLOR	TERMINAL	1	N107C	18	TN	3518963C1	2	N107B	18	TN	3518963C1	3	N107A	18	TN	3518963C1	4	PLUG	-	-	3527276C1	5	N108A	18	TN	3518963C1	6	N108B	18	TN	3518963C1	7	N108C	18	TN	3518963C1	8	N108D	18	TN	3518963C1	9	N108E	18	TN	3518963C1	10	N108F	18	TN	3518963C1	11	PLUG	-	-	3527276C1	12	PLUG	-	-	3527276C1																																																																									
CAV	CIR	GAUGE	COLOR	TERMINAL																																																																																																																																													
1	N107C	18	TN	3518963C1																																																																																																																																													
2	N107B	18	TN	3518963C1																																																																																																																																													
3	N107A	18	TN	3518963C1																																																																																																																																													
4	PLUG	-	-	3527276C1																																																																																																																																													
5	N108A	18	TN	3518963C1																																																																																																																																													
6	N108B	18	TN	3518963C1																																																																																																																																													
7	N108C	18	TN	3518963C1																																																																																																																																													
8	N108D	18	TN	3518963C1																																																																																																																																													
9	N108E	18	TN	3518963C1																																																																																																																																													
10	N108F	18	TN	3518963C1																																																																																																																																													
11	PLUG	-	-	3527276C1																																																																																																																																													
12	PLUG	-	-	3527276C1																																																																																																																																													
CHK	DATE	CHANGE	REV	REFERENCE	DRAWN	NAME																																																																																																																																											
CNA1	07OCT09	W484//ADDED CONN 8902.	C	62556A	U00K640	CIRCUIT DIAGRAM, PROSTAR, LONESTAR																																																																																																																																											
RELEASE NO.	DATE	PART NO.	SHEET																																																																																																																																														
59637L	11SEP06	AE08055906	103																																																																																																																																														

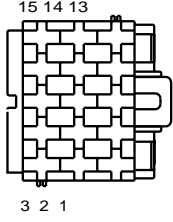
Figure 365 Connector Composites (8900), (8901), (8902), (8950), (8951)

14.137. CONNECTOR COMPOSITES (8952), (8953/8954M/8953F), P. 104

<p>INTERNATIONAL TRUCK AND ENGINE CORPORATION</p> <p>THIS PRINT IS PROVIDED ON A RESTRICTED BASIS AND IS NOT TO BE USED IN ANY WAY DETRIMENTAL TO THE INTEREST OF INTERNATIONAL TRUCK AND ENGINE CORPORATION.</p>	<p>ELECTRICAL CIRCUIT DIAGRAM CHAPTER 14</p> <p>CONNECTOR BODY COMPOSITE - MATING VIEW SHOWN</p>
---	--

TIRE PRESSURE MONITORING SYSTEM (TPMS) CONTROLLER (8952)  
(LOCATED ON MODULE BRACKET (IN CAM) (W/ PROSTAR)



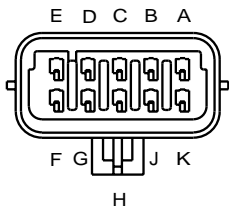
15 14 13  
3 2 1

BODY LOCK 3596928C1

CAV	CIR	GAUGE	COLOR	TERMINAL
1	D22-G	18	WH	3598072C1
2	D22E	18	TN	3598072C1
3	D22D	18	TN	3598072C1
4	D22C	18	TN	3598072C1
5	D22B	18	TN	3598072C1
6	D22A	18	TN	3598072C1
7	D22VC	18	TN	3598072C1
8	D22VB	18	TN	3598072C1
9	D22VA	18	TN	3598072C1
10	D22ZA	18	TN	3598072C1
11	D22ZB	18	TN	3598072C1
12	D22ZC	18	TN	3598072C1
13	D5 (+)	18	GN	3598072C1
14	-	-	-	-
15	D5 (-)	18	YL	3598072C1

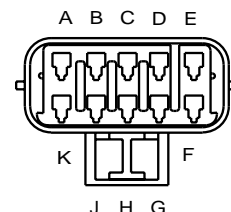
  

FORWARD / CENTER PROGNOSTICS & DIAGNOSTICS (8953 / #8954M / #8953F)  
(LOCATED ON LEFT SIDE DASH PANEL)



E D C B A  
F G J K  
H

CONNECTOR 3538635C1  
BODY LOCK 3538636C1



A B C D E  
K J H G

CONNECTOR 3538635C1  
BODY LOCK 3538636C1

CAV	CIR	GAUGE	COLOR	TERMINAL	SEAL/SLEEVE
A	M108A	18	TN	1667742C1	1661872C1
B	M108VA	16	TN	1667742C1	1661872C1
C	M108B	18	TN	1667742C1	1661872C1
D	M110V	16	TN	1667742C1	1661872C1
E	-	-	-	-	-
F	M110A	18	TN	1667742C1	1661872C1
G	M107A	18	TN	1667742C1	1661872C1
H	M107-GA	18	TN	1667742C1	1661872C1
J	M108ZA	16	TN	1667742C1	1661872C1
K	M110ZA	18	TN	1667742C1	1661872C1

CAV	CIR	GAUGE	COLOR	TERMINAL	SEAL/SLEEVE
A	N108A	18	TN	1661875C1	1661872C1
B	N108VA	16	TN	1661875C1	1661872C1
C	N108B	18	TN	1661875C1	1661872C1
D	N110V	16	TN	1661875C1	1661872C1
E	-	-	-	-	-
F	N110B	18	TN	1661875C1	1661872C1
G	N107A	18	TN	1661875C1	1661872C1
H	N107-GA	18	TN	1661875C1	1661872C1
J	N108ZA	16	TN	1661875C1	1661872C1
K	N110Z	16	TN	1661875C1	1661872C1

# W/ LONESTAR

CHK	DATE	CHANGE	REV	REFERENCE	DRAWN	NAME
CNA1	14JAN09	ADDED LONESTAR EFFECT	B	61254R	U00K640	CIRCUIT DIAGRAM, PROSTAR, LONESTAR
					RELEASE NO. 59637L	DATE 11SEP06
						PART NO. AE08055906
						SHEET 104

Figure 366 Connector Composites (8952), (8953/8954M/8953F)

14.138. CONNECTOR COMPOSITES (8954), (8954M), (8960), (8961), (8962), P. 105

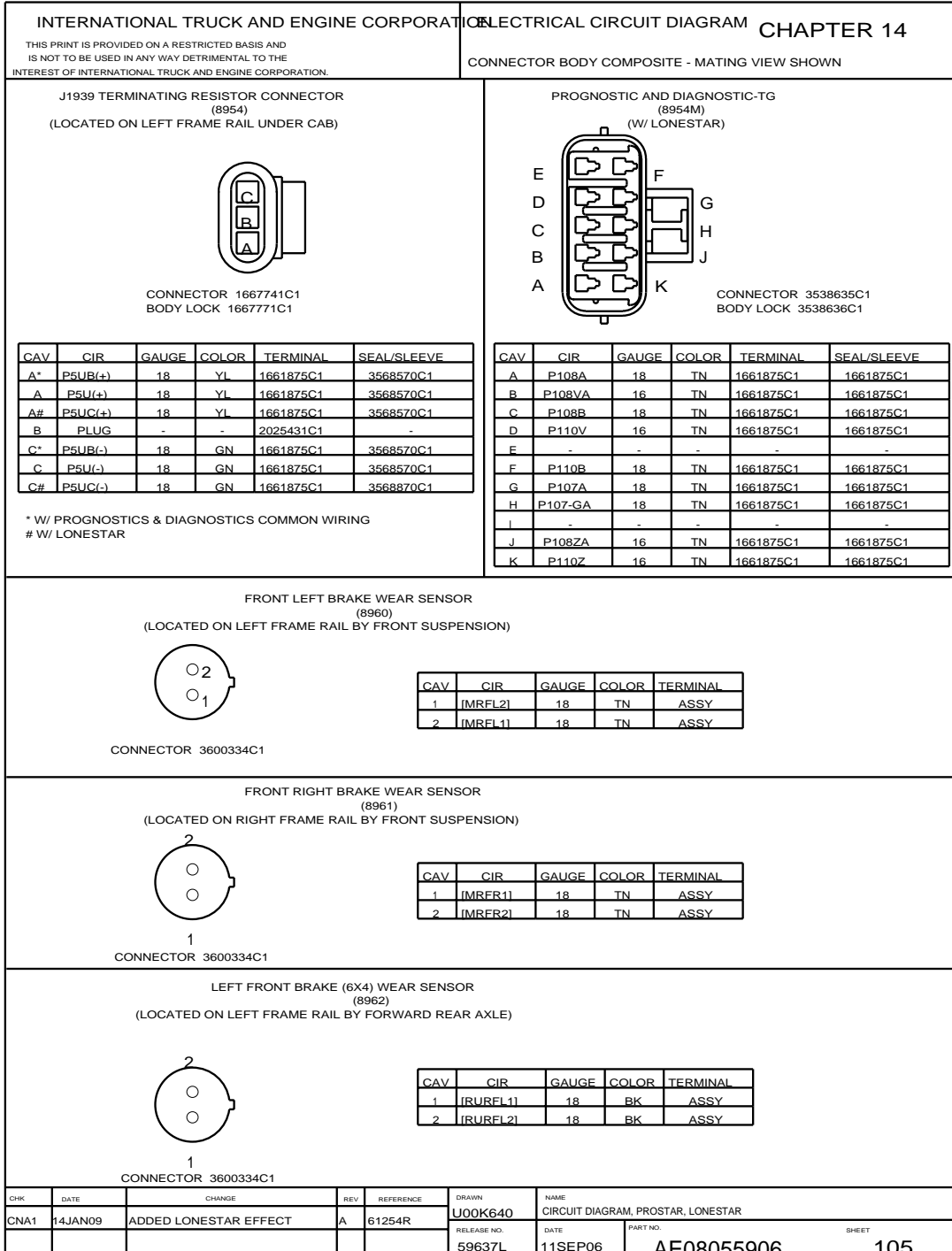
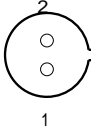
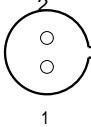
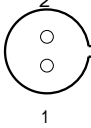
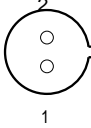
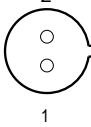


Figure 367 Connector Composites (8954), (8954M), (8960), (8961), (8962)

14.139. CONNECTOR COMPOSITES (8963), (8964), (8965), (8966), (8967), P. 106

INTERNATIONAL TRUCK AND ENGINE CORPORATION		ELECTRICAL CIRCUIT DIAGRAM CHAPTER 14		
THIS PRINT IS PROVIDED ON A RESTRICTED BASIS AND IS NOT TO BE USED IN ANY WAY DETRIMENTAL TO THE INTEREST OF INTERNATIONAL TRUCK AND ENGINE CORPORATION.		CONNECTOR BODY COMPOSITE - MATING VIEW SHOWN		

<p>RIGHT FRONT BRAKE (6X4) WEAR SENSOR (8963) (LOCATED ON RIGHT FRAME RAIL BY FORWARD REAR AXLE)</p>  <p>CONNECTOR 3600334C1</p>	<table border="1" style="width:100%; border-collapse: collapse; font-size: x-small;"> <thead> <tr> <th>CAV</th> <th>CIR</th> <th>GAUGE</th> <th>COLOR</th> <th>TERMINAL</th> </tr> </thead> <tbody> <tr> <td>1</td> <td>IRURFR1</td> <td>18</td> <td>BK</td> <td>ASSY</td> </tr> <tr> <td>2</td> <td>IRURFR2</td> <td>18</td> <td>BK</td> <td>ASSY</td> </tr> </tbody> </table>	CAV	CIR	GAUGE	COLOR	TERMINAL	1	IRURFR1	18	BK	ASSY	2	IRURFR2	18	BK	ASSY
CAV	CIR	GAUGE	COLOR	TERMINAL												
1	IRURFR1	18	BK	ASSY												
2	IRURFR2	18	BK	ASSY												
<p>LEFT REAR BRAKE (6X4) WEAR SENSOR (8964) (LOCATED ON LEFT FRAME RAIL BY REAR AXLE)</p>  <p>CONNECTOR 3600334C1</p>	<table border="1" style="width:100%; border-collapse: collapse; font-size: x-small;"> <thead> <tr> <th>CAV</th> <th>CIR</th> <th>GAUGE</th> <th>COLOR</th> <th>TERMINAL</th> </tr> </thead> <tbody> <tr> <td>1</td> <td>IRURRL1</td> <td>18</td> <td>BK</td> <td>ASSY</td> </tr> <tr> <td>2</td> <td>IRURRL2</td> <td>18</td> <td>BK</td> <td>ASSY</td> </tr> </tbody> </table>	CAV	CIR	GAUGE	COLOR	TERMINAL	1	IRURRL1	18	BK	ASSY	2	IRURRL2	18	BK	ASSY
CAV	CIR	GAUGE	COLOR	TERMINAL												
1	IRURRL1	18	BK	ASSY												
2	IRURRL2	18	BK	ASSY												
<p>RIGHT REAR BRAKE (6X4) WEAR SENSOR (8965) (LOCATED ON RIGHT FRAME RAIL BY REAR AXLE)</p>  <p>CONNECTOR 3600334C1</p>	<table border="1" style="width:100%; border-collapse: collapse; font-size: x-small;"> <thead> <tr> <th>CAV</th> <th>CIR</th> <th>GAUGE</th> <th>COLOR</th> <th>TERMINAL</th> </tr> </thead> <tbody> <tr> <td>1</td> <td>IRURRR1</td> <td>18</td> <td>BK</td> <td>ASSY</td> </tr> <tr> <td>2</td> <td>IRURRR2</td> <td>18</td> <td>BK</td> <td>ASSY</td> </tr> </tbody> </table>	CAV	CIR	GAUGE	COLOR	TERMINAL	1	IRURRR1	18	BK	ASSY	2	IRURRR2	18	BK	ASSY
CAV	CIR	GAUGE	COLOR	TERMINAL												
1	IRURRR1	18	BK	ASSY												
2	IRURRR2	18	BK	ASSY												
<p>LEFT REAR (4X2) WEAR SENSOR (8966) (LOCATED ON LEFT FRAME BY REAR AXLE)</p>  <p>CONNECTOR 3600334C1</p>	<table border="1" style="width:100%; border-collapse: collapse; font-size: x-small;"> <thead> <tr> <th>CAV</th> <th>CIR</th> <th>GAUGE</th> <th>COLOR</th> <th>TERMINAL</th> </tr> </thead> <tbody> <tr> <td>1</td> <td>IRTRRL1</td> <td>18</td> <td>BK</td> <td>ASSY</td> </tr> <tr> <td>2</td> <td>IRTRRL2</td> <td>18</td> <td>BK</td> <td>ASSY</td> </tr> </tbody> </table>	CAV	CIR	GAUGE	COLOR	TERMINAL	1	IRTRRL1	18	BK	ASSY	2	IRTRRL2	18	BK	ASSY
CAV	CIR	GAUGE	COLOR	TERMINAL												
1	IRTRRL1	18	BK	ASSY												
2	IRTRRL2	18	BK	ASSY												
<p>REAR BRAKE (4X2) WEAR SENSOR (8967) (LOCATED ON RIGHT FRAME RAIL BY REAR AXLE)</p>  <p>CONNECTOR 3600334C1</p>	<table border="1" style="width:100%; border-collapse: collapse; font-size: x-small;"> <thead> <tr> <th>CAV</th> <th>CIR</th> <th>GAUGE</th> <th>COLOR</th> <th>TERMINAL</th> </tr> </thead> <tbody> <tr> <td>1</td> <td>IRTRRR1</td> <td>18</td> <td>BK</td> <td>ASSY</td> </tr> <tr> <td>2</td> <td>IRTRRR2</td> <td>18</td> <td>BK</td> <td>ASSY</td> </tr> </tbody> </table>	CAV	CIR	GAUGE	COLOR	TERMINAL	1	IRTRRR1	18	BK	ASSY	2	IRTRRR2	18	BK	ASSY
CAV	CIR	GAUGE	COLOR	TERMINAL												
1	IRTRRR1	18	BK	ASSY												
2	IRTRRR2	18	BK	ASSY												

CHK	DATE	CHANGE	REV	REFERENCE	DRAWN	NAME
CNA1	14JAN09	TITLE WAS CIRCUIT	A	61254R	U00K640	CIRCUIT DIAGRAM, PROSTAR, LONESTAR
		DIAGRAM, PROSTAR			59637L	AE08055906
						11SEP06
						PART NO.
						DATE
						SHEET
						106


Figure 368 Connector Composites (8963), (8964), (8965), (8966), (8967)

14.140. CONNECTOR COMPOSITES (8970), (8971), (8972), (8973), P. 107

INTERNATIONAL TRUCK AND ENGINE CORPORATION				ELECTRICAL CIRCUIT DIAGRAM CHAPTER 14	
THIS PRINT IS PROVIDED ON A RESTRICTED BASIS AND IS NOT TO BE USED IN ANY WAY DETRIMENTAL TO THE INTEREST OF INTERNATIONAL TRUCK AND ENGINE CORPORATION.				CONNECTOR BODY COMPOSITE - MATING VIEW SHOWN	

FRONT LEFT BRAKE STROKE  
(8970)  
(LOCATED ON LEFT FRAME RAIL BY FRONT AXLE)

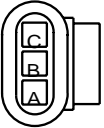


CAV	CIR	GAUGE	COLOR	TERMINAL	SEAL/SLEEVE
A	M108VD	18	TN	1661875C1	1661872C1
B	M108ZD	18	TN	1661875C1	1661872C1
C	M108A	18	TN	1661875C1	1661872C1

CONNECTOR 1667741C1  
BODY LOCK 1667771C1

FRONT RIGHT BRAKE STROKE  
(8971)  
(LOCATED ON RIGHT FRAME RAIL BY FRONT AXLE)




CAV	CIR	GAUGE	COLOR	TERMINAL	SEAL/SLEEVE
A	M108VC	18	TN	1661875C1	1661872C1
B	M108ZC	18	TN	1661875C1	1661872C1
C	M108B	18	TN	1661875C1	1661872C1

CONNECTOR 1667741C1  
BODY LOCK 1667771C1

LEFT FR BRAKE STROKE (6X4)  
(8972)  
(LOCATED ON LEFT FRAME RAIL BY FORWARD REAR AXLE)




CAV	CIR	GAUGE	COLOR	TERMINAL	SEAL/SLEEVE
A	R108VE	18	TN	1661875C1	1661872C1
B	R108ZE	18	TN	1661875C1	1661872C1
C	R108E	18	TN	1661875C1	1661872C1

CONNECTOR 1667741C1  
BODY LOCK 1667771C1

RIGHT FR BRAKE STROKE (6X4)  
(8973)  
(LOCATED ON RIGHT FRAME RAIL BY FORWARD REAR AXLE)



CAV	CIR	GAUGE	COLOR	TERMINAL	SEAL/SLEEVE
A	R108VL	18	TN	1661875C1	1661872C1
B	R108ZL	18	TN	1661875C1	1661872C1
C	R108F	18	TN	1661875C1	1661872C1

CONNECTOR 1667741C1  
BODY LOCK 1667771C1

CHK	DATE	CHANGE	REV	REFERENCE	DRAWN	NAME
CNA1	14JAN09	TITLE WAS CIRCUIT	A	61254R	U00K640	CIRCUIT DIAGRAM, PROSTAR, LONESTAR
		DIAGRAM, PROSTAR			59637L	
					11SEP06	AE08055906
						107

Figure 369 Connector Composites (8970), (8971), (8972), (8973)

14.141. CONNECTOR COMPOSITES (8974), (8975), (8976), (8977), P. 108

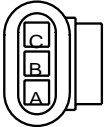
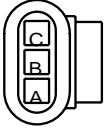

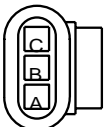
INTERNATIONAL TRUCK AND ENGINE CORPORATION		ELECTRICAL CIRCUIT DIAGRAM		CHAPTER 14																									
THIS PRINT IS PROVIDED ON A RESTRICTED BASIS AND IS NOT TO BE USED IN ANY WAY DETRIMENTAL TO THE INTEREST OF INTERNATIONAL TRUCK AND ENGINE CORPORATION.		CONNECTOR BODY COMPOSITE - MATING VIEW SHOWN																											
<p>LEFT REAR BRAKE STROKE (6X4) (8974) (LOCATED ON LEFT FRAME RAIL BY REAR AXLE)</p>  <table border="1" style="margin-left: auto; margin-right: auto;"> <thead> <tr> <th>CAV</th> <th>CIR</th> <th>GAUGE</th> <th>COLOR</th> <th>TERMINAL</th> <th>SEAL/SLEEVE</th> </tr> </thead> <tbody> <tr> <td>A</td> <td>R108VH</td> <td>18</td> <td>TN</td> <td>1661875C1</td> <td>1661872C1</td> </tr> <tr> <td>B</td> <td>R108ZH</td> <td>18</td> <td>TN</td> <td>1661875C1</td> <td>1661872C1</td> </tr> <tr> <td>C</td> <td>R108CA</td> <td>18</td> <td>TN</td> <td>1661875C1</td> <td>1661872C1</td> </tr> </tbody> </table> <p>CONNECTOR 1667741C1 BODY LOCK 166771C1</p>						CAV	CIR	GAUGE	COLOR	TERMINAL	SEAL/SLEEVE	A	R108VH	18	TN	1661875C1	1661872C1	B	R108ZH	18	TN	1661875C1	1661872C1	C	R108CA	18	TN	1661875C1	1661872C1
CAV	CIR	GAUGE	COLOR	TERMINAL	SEAL/SLEEVE																								
A	R108VH	18	TN	1661875C1	1661872C1																								
B	R108ZH	18	TN	1661875C1	1661872C1																								
C	R108CA	18	TN	1661875C1	1661872C1																								
<p>RIGHT REAR BRAKE STROKE (6X4) (8975) (LOCATED ON RIGHT RAIL FRAME BY RAER AXLE)</p>  <table border="1" style="margin-left: auto; margin-right: auto;"> <thead> <tr> <th>CAV</th> <th>CIR</th> <th>GAUGE</th> <th>COLOR</th> <th>TERMINAL</th> <th>SEAL/SLEEVE</th> </tr> </thead> <tbody> <tr> <td>A</td> <td>R108VJ</td> <td>18</td> <td>TN</td> <td>1661875C1</td> <td>1661872C1</td> </tr> <tr> <td>B</td> <td>R108ZJ</td> <td>18</td> <td>TN</td> <td>1661875C1</td> <td>1661872C1</td> </tr> <tr> <td>C</td> <td>R108DA</td> <td>18</td> <td>TN</td> <td>1661875C1</td> <td>1661872C1</td> </tr> </tbody> </table> <p>CONNECTOR 1667741C1 BODY LOCK 166771C1</p>						CAV	CIR	GAUGE	COLOR	TERMINAL	SEAL/SLEEVE	A	R108VJ	18	TN	1661875C1	1661872C1	B	R108ZJ	18	TN	1661875C1	1661872C1	C	R108DA	18	TN	1661875C1	1661872C1
CAV	CIR	GAUGE	COLOR	TERMINAL	SEAL/SLEEVE																								
A	R108VJ	18	TN	1661875C1	1661872C1																								
B	R108ZJ	18	TN	1661875C1	1661872C1																								
C	R108DA	18	TN	1661875C1	1661872C1																								
<p>LEFT REAR BRAKE STROKE (4X2) (8976) (LOCATED ON LEFT FRAME RAIL BY REAR AXLE)</p>  <table border="1" style="margin-left: auto; margin-right: auto;"> <thead> <tr> <th>CAV</th> <th>CIR</th> <th>GAUGE</th> <th>COLOR</th> <th>TERMINAL</th> <th>SEAL/SLEEVE</th> </tr> </thead> <tbody> <tr> <td>A</td> <td>R108VF</td> <td>18</td> <td>TN</td> <td>1661875C1</td> <td>1661872C1</td> </tr> <tr> <td>B</td> <td>R108ZF</td> <td>18</td> <td>TN</td> <td>1661875C1</td> <td>1661872C1</td> </tr> <tr> <td>C</td> <td>R108C</td> <td>18</td> <td>TN</td> <td>1661875C1</td> <td>1661872C1</td> </tr> </tbody> </table> <p>CONNECTOR 1667741C1 BODY LOCK 166771C1</p>						CAV	CIR	GAUGE	COLOR	TERMINAL	SEAL/SLEEVE	A	R108VF	18	TN	1661875C1	1661872C1	B	R108ZF	18	TN	1661875C1	1661872C1	C	R108C	18	TN	1661875C1	1661872C1
CAV	CIR	GAUGE	COLOR	TERMINAL	SEAL/SLEEVE																								
A	R108VF	18	TN	1661875C1	1661872C1																								
B	R108ZF	18	TN	1661875C1	1661872C1																								
C	R108C	18	TN	1661875C1	1661872C1																								
<p>RIGHT REAR BRAKE STROKE (4X2) (8977) (LOCATED ON RIGHT FRAME RAIL BY REAR AXLE)</p>  <table border="1" style="margin-left: auto; margin-right: auto;"> <thead> <tr> <th>CAV</th> <th>CIR</th> <th>GAUGE</th> <th>COLOR</th> <th>TERMINAL</th> <th>SEAL/SLEEVE</th> </tr> </thead> <tbody> <tr> <td>A</td> <td>R108VK</td> <td>18</td> <td>TN</td> <td>1661875C1</td> <td>1661872C1</td> </tr> <tr> <td>B</td> <td>R108ZK</td> <td>18</td> <td>TN</td> <td>1661875C1</td> <td>1661872C1</td> </tr> <tr> <td>C</td> <td>R108D</td> <td>18</td> <td>TN</td> <td>1661875C1</td> <td>1661872C1</td> </tr> </tbody> </table> <p>CONNECTOR 1667741C1 BODY LOCK 166771C1</p>						CAV	CIR	GAUGE	COLOR	TERMINAL	SEAL/SLEEVE	A	R108VK	18	TN	1661875C1	1661872C1	B	R108ZK	18	TN	1661875C1	1661872C1	C	R108D	18	TN	1661875C1	1661872C1
CAV	CIR	GAUGE	COLOR	TERMINAL	SEAL/SLEEVE																								
A	R108VK	18	TN	1661875C1	1661872C1																								
B	R108ZK	18	TN	1661875C1	1661872C1																								
C	R108D	18	TN	1661875C1	1661872C1																								
CHK	DATE	CHANGE	REV	REFERENCE	DRAWN	NAME																							
CNA1	14JAN09	TITLE WAS CIRCUIT	A	61254R	U00K640	CIRCUIT DIAGRAM, PROSTAR, LONESTAR																							
		DIAGRAM, PROSTAR			RELEASE NO. 59637L	DATE 11SEP06																							
						PART NO. AE08055906																							
						SHEET 108																							

Figure 370 Connector Composites (8974), (8975), (8976), (8977)

14.142. CONNECTOR COMPOSITES (8980), (8981), (8982), (8983), (8984), P. 109

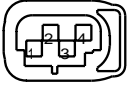
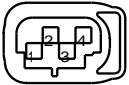
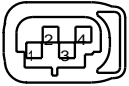
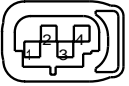
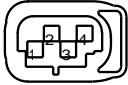
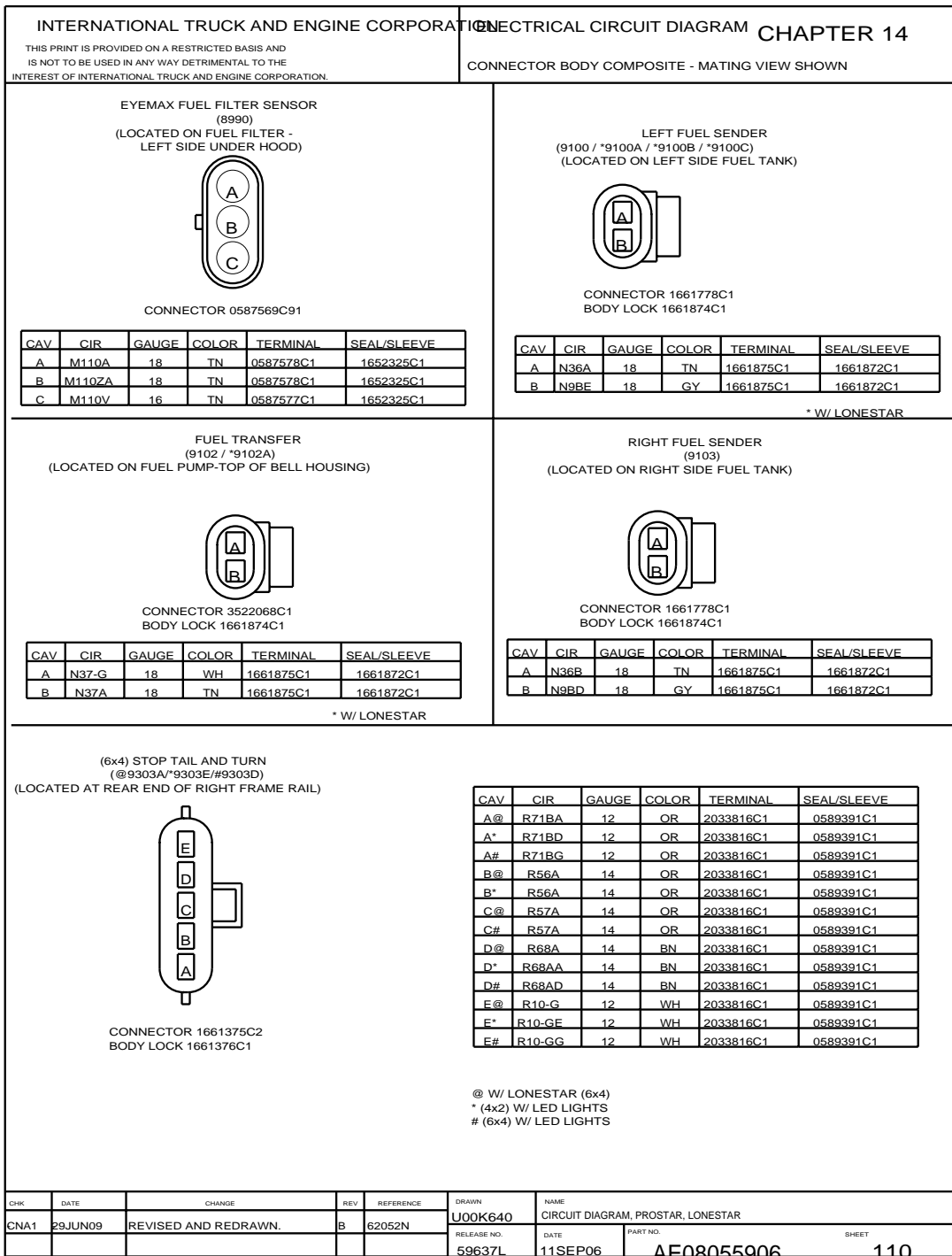
INTERNATIONAL TRUCK AND ENGINE CORPORATION				ELECTRICAL CIRCUIT DIAGRAM CHAPTER 14																															
THIS PRINT IS PROVIDED ON A RESTRICTED BASIS AND IS NOT TO BE USED IN ANY WAY DETRIMENTAL TO THE INTEREST OF INTERNATIONAL TRUCK AND ENGINE CORPORATION.				CONNECTOR BODY COMPOSITE - MATING VIEW SHOWN																															
<p>FRONT TIRE PRESSURE MONITOR (8980) (LOCATED ON ENGINE CROSS MEMBER)</p>																																			
		<table border="1" style="width:100%; border-collapse: collapse; font-size: x-small;"> <thead> <tr> <th>CAV</th> <th>CIR</th> <th>GAUGE</th> <th>COLOR</th> <th>TERMINAL</th> <th>SEAL/SLEEVE</th> </tr> </thead> <tbody> <tr> <td>1</td> <td>M22ZA</td> <td>20</td> <td>TN</td> <td>3600325C1</td> <td>3600327C1</td> </tr> <tr> <td>2</td> <td>M22VA</td> <td>20</td> <td>TN</td> <td>3600325C1</td> <td>3600327C1</td> </tr> <tr> <td>3</td> <td>M22A</td> <td>20</td> <td>TN</td> <td>3600325C1</td> <td>3600327C1</td> </tr> <tr> <td>4</td> <td>PLUG</td> <td>-</td> <td>-</td> <td>3600328C1</td> <td>-</td> </tr> </tbody> </table>				CAV	CIR	GAUGE	COLOR	TERMINAL	SEAL/SLEEVE	1	M22ZA	20	TN	3600325C1	3600327C1	2	M22VA	20	TN	3600325C1	3600327C1	3	M22A	20	TN	3600325C1	3600327C1	4	PLUG	-	-	3600328C1	-
CAV	CIR	GAUGE	COLOR	TERMINAL	SEAL/SLEEVE																														
1	M22ZA	20	TN	3600325C1	3600327C1																														
2	M22VA	20	TN	3600325C1	3600327C1																														
3	M22A	20	TN	3600325C1	3600327C1																														
4	PLUG	-	-	3600328C1	-																														
CONNECTOR 3600324C1																																			
<p>LEFT REAR TIRE PRESSURE MONITOR (8981) (LOCATED ON LEFT FRAME RAIL BY REAR AXLE(S))</p>																																			
		<table border="1" style="width:100%; border-collapse: collapse; font-size: x-small;"> <thead> <tr> <th>CAV</th> <th>CIR</th> <th>GAUGE</th> <th>COLOR</th> <th>TERMINAL</th> <th>SEAL/SLEEVE</th> </tr> </thead> <tbody> <tr> <td>1</td> <td>R22ZB</td> <td>20</td> <td>TN</td> <td>3600325C1</td> <td>3600327C1</td> </tr> <tr> <td>2</td> <td>R22VB</td> <td>20</td> <td>TN</td> <td>3600325C1</td> <td>3600327C1</td> </tr> <tr> <td>3</td> <td>R22B</td> <td>20</td> <td>TN</td> <td>3600325C1</td> <td>3600327C1</td> </tr> <tr> <td>4</td> <td>PLUG</td> <td>-</td> <td>-</td> <td>3600328C1</td> <td>-</td> </tr> </tbody> </table>				CAV	CIR	GAUGE	COLOR	TERMINAL	SEAL/SLEEVE	1	R22ZB	20	TN	3600325C1	3600327C1	2	R22VB	20	TN	3600325C1	3600327C1	3	R22B	20	TN	3600325C1	3600327C1	4	PLUG	-	-	3600328C1	-
CAV	CIR	GAUGE	COLOR	TERMINAL	SEAL/SLEEVE																														
1	R22ZB	20	TN	3600325C1	3600327C1																														
2	R22VB	20	TN	3600325C1	3600327C1																														
3	R22B	20	TN	3600325C1	3600327C1																														
4	PLUG	-	-	3600328C1	-																														
CONNECTOR 3600324C1																																			
<p>RIGHT REAR TIRE PRESSURE MONITOR (8982) (LOCATED ON RIGHT FRAME RAIL BY REAR AXLE(S))</p>																																			
		<table border="1" style="width:100%; border-collapse: collapse; font-size: x-small;"> <thead> <tr> <th>CAV</th> <th>CIR</th> <th>GAUGE</th> <th>COLOR</th> <th>TERMINAL</th> <th>SEAL/SLEEVE</th> </tr> </thead> <tbody> <tr> <td>1</td> <td>R22ZC</td> <td>20</td> <td>TN</td> <td>3600325C1</td> <td>3600327C1</td> </tr> <tr> <td>2</td> <td>R22VC</td> <td>20</td> <td>TN</td> <td>3600325C1</td> <td>3600327C1</td> </tr> <tr> <td>3</td> <td>R22C</td> <td>20</td> <td>TN</td> <td>3600325C1</td> <td>3600327C1</td> </tr> <tr> <td>4</td> <td>PLUG</td> <td>-</td> <td>-</td> <td>3600328C1</td> <td>-</td> </tr> </tbody> </table>				CAV	CIR	GAUGE	COLOR	TERMINAL	SEAL/SLEEVE	1	R22ZC	20	TN	3600325C1	3600327C1	2	R22VC	20	TN	3600325C1	3600327C1	3	R22C	20	TN	3600325C1	3600327C1	4	PLUG	-	-	3600328C1	-
CAV	CIR	GAUGE	COLOR	TERMINAL	SEAL/SLEEVE																														
1	R22ZC	20	TN	3600325C1	3600327C1																														
2	R22VC	20	TN	3600325C1	3600327C1																														
3	R22C	20	TN	3600325C1	3600327C1																														
4	PLUG	-	-	3600328C1	-																														
CONNECTOR 3600324C1																																			
<p>LEFT REAR TIRE PRESSURE MONITOR(6X4) (8983) (LOCATED ON RIGHT FRAME RAIL BY REAR AXLE(S)) (W/ LONESTAR)</p>																																			
		<table border="1" style="width:100%; border-collapse: collapse; font-size: x-small;"> <thead> <tr> <th>CAV</th> <th>CIR</th> <th>GAUGE</th> <th>COLOR</th> <th>TERMINAL</th> <th>SEAL/SLEEVE</th> </tr> </thead> <tbody> <tr> <td>1</td> <td>R22ZB</td> <td>20</td> <td>TN</td> <td>3600325C1</td> <td>3600327C1</td> </tr> <tr> <td>2</td> <td>R22VB</td> <td>20</td> <td>TN</td> <td>3600325C1</td> <td>3600327C1</td> </tr> <tr> <td>3</td> <td>R22B</td> <td>20</td> <td>TN</td> <td>3600325C1</td> <td>3600327C1</td> </tr> <tr> <td>4</td> <td>PLUG</td> <td>-</td> <td>-</td> <td>3600328C1</td> <td>-</td> </tr> </tbody> </table>				CAV	CIR	GAUGE	COLOR	TERMINAL	SEAL/SLEEVE	1	R22ZB	20	TN	3600325C1	3600327C1	2	R22VB	20	TN	3600325C1	3600327C1	3	R22B	20	TN	3600325C1	3600327C1	4	PLUG	-	-	3600328C1	-
CAV	CIR	GAUGE	COLOR	TERMINAL	SEAL/SLEEVE																														
1	R22ZB	20	TN	3600325C1	3600327C1																														
2	R22VB	20	TN	3600325C1	3600327C1																														
3	R22B	20	TN	3600325C1	3600327C1																														
4	PLUG	-	-	3600328C1	-																														
CONNECTOR 3600324C1																																			
<p>RIGHT REAR TIRE PRESSURE MONITOR(6X4) (8984) (LOCATED ON RIGHT FRAME RAIL BY REAR AXLE(S)) (W/ LONESTAR)</p>																																			
		<table border="1" style="width:100%; border-collapse: collapse; font-size: x-small;"> <thead> <tr> <th>CAV</th> <th>CIR</th> <th>GAUGE</th> <th>COLOR</th> <th>TERMINAL</th> <th>SEAL/SLEEVE</th> </tr> </thead> <tbody> <tr> <td>1</td> <td>R22ZB</td> <td>20</td> <td>TN</td> <td>3600325C1</td> <td>3600327C1</td> </tr> <tr> <td>2</td> <td>R22VC</td> <td>20</td> <td>TN</td> <td>3600325C1</td> <td>3600327C1</td> </tr> <tr> <td>3</td> <td>R22C</td> <td>20</td> <td>TN</td> <td>3600325C1</td> <td>3600327C1</td> </tr> <tr> <td>4</td> <td>PLUG</td> <td>-</td> <td>-</td> <td>3600328C1</td> <td>-</td> </tr> </tbody> </table>				CAV	CIR	GAUGE	COLOR	TERMINAL	SEAL/SLEEVE	1	R22ZB	20	TN	3600325C1	3600327C1	2	R22VC	20	TN	3600325C1	3600327C1	3	R22C	20	TN	3600325C1	3600327C1	4	PLUG	-	-	3600328C1	-
CAV	CIR	GAUGE	COLOR	TERMINAL	SEAL/SLEEVE																														
1	R22ZB	20	TN	3600325C1	3600327C1																														
2	R22VC	20	TN	3600325C1	3600327C1																														
3	R22C	20	TN	3600325C1	3600327C1																														
4	PLUG	-	-	3600328C1	-																														
CONNECTOR 3600324C1																																			
CHK	DATE	CHANGE	REV	REFERENCE	DRAWN	NAME																													
CNA1	14JAN09	ADDED LONESTAR EFFECT	A	61254R	U00K640	CIRCUIT DIAGRAM, PROSTAR, LONESTAR																													
					RELEASE NO.	DATE																													
					59637L	11SEP06																													
					PART NO.	SHEET																													
					AE08055906	109																													

Figure 371 Connector Composites (8980), (8981), (8982), (8983), (8984)

**14.143. CONNECTOR COMPOSITES (8990), (9100/9100A/9100B/9100C), (9102/9102A) (9103), (9303A/9303E/9303D), P. 110**



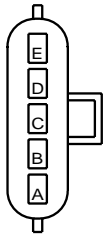
**Figure 372 Connector Composites (8990), (9100/9100A/9100B/9100C), (9102/9102A) (9103), (9303A/9303E/9303D)**

14.144. CONNECTOR COMPOSITES (9303/9303C/9303B), (9304A), (9305/9305A), P. 111

INTERNATIONAL TRUCK AND ENGINE CORPORATION				ELECTRICAL CIRCUIT DIAGRAM CHAPTER 14	
THIS PRINT IS PROVIDED ON A RESTRICTED BASIS AND IS NOT TO BE USED IN ANY WAY DETRIMENTAL TO THE INTEREST OF INTERNATIONAL TRUCK AND ENGINE CORPORATION.				CONNECTOR BODY COMPOSITE - MATING VIEW SHOWN	

STOP TAIL AND TURN  
(@9303/\*9303C/#9303B) - COMMON BASE (4X2)  
(9304 - COMMON BASE - LONESTAR (6x4)  
(LOCATED AT REAR END OF LEFT FRAME RAIL)



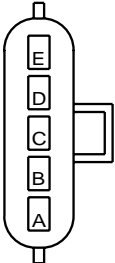
CONNECTOR 1661375C2  
BODY LOCK 1661376C1

CAV	CIR	GAUGE	COLOR	TERMINAL	SEAL/SLEEVE
A@	R71BA	12	OR	2033816C1	0589391C1
A*	R71BC	12	OR	2033816C1	0589391C1
A#	R71BE	12	OR	2033816C1	0589391C1
B@	R56A	14	OR	2033816C1	0589391C1
B#	R56A	14	OR	2033816C1	0589391C1
C@	R57A	14	OR	2033816C1	0589391C1
C*	R57A	14	OR	2033816C1	0589391C1
D@	R68A	14	BN	2033816C1	0589391C1
D*	R68AB	14	BN	2033816C1	0589391C1
D#	R68AC	14	BN	2033816C1	0589391C1
E@	R10-G	12	WH	2033816C1	0589391C1
E*	R10-GC	12	WH	2033816C1	0589391C1
E#	R10-GE	12	WH	2033816C1	0589391C1

@ W/ LONESTAR (6x4)  
\* (4x2) W/ LED LIGHTS  
# (6x4) W/ LED LIGHTS

(6x4) STOP TAIL AND TURN LONESTAR  
(9304A)  
(LOCATED AT REAR END OF LEFT FRAME RAIL)  
(W/ LONESTAR)

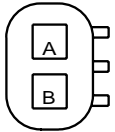


CONNECTOR 1661375C2  
BODY LOCK 1661376C1

CAV	CIR	GAUGE	COLOR	TERMINAL	SEAL/SLEEVE
A	R71BA	12	OR	2033816C1	0589391C1
B	R56A	14	OR	2033816C1	0589391C1
C	R57A	14	OR	2033816C1	0589391C1
D	R68A	14	BN	2033816C1	0589391C1
E	R10-GA	16	WH	2033816C1	0589391C1

BACK-UPALARM  
(\*9305/#9305A)  
(LOCATED AT REAR END OF LEFT FRAME RAIL)



CONNECTOR 1671611C1  
BODY LOCK 1671608C1

CAV	CIR	GAUGE	COLOR	TERMINAL	SEAL/SLEEVE
A*	R71BF	12	OR	2033912C1	0589390C1
A#	R71BB	12	WH	2033912C1	0589391C1
B*	R10-GF	12	WH	2033912C1	0589391C1
B#	R10-GD	12	OR	2033912C1	0589390C1

\* (6x4) W/ LED LIGHTS  
# (4x2) W/ LED LIGHTS

CHK	DATE	CHANGE	REV	REFERENCE	DRAWN	NAME
CNA1	29JUN09	REVISED AND REDRAWN.	D	62052N	U00K640	CIRCUIT DIAGRAM, PROSTAR, LONESTAR
					RELEASE NO. 59637L	DATE 11SEP06 PART NO. AE08055906 SHEET 111

Figure 373 Connector Composites (9103), (9303), (9303A), (9304), (9304A)

14.145. CONNECTOR COMPOSITES (9501), (9501D), (9502/9502A), (9502B), (9503/9503D), (9504/9504A/9504B), P. 112



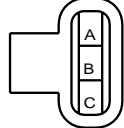
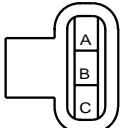

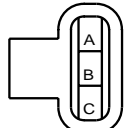
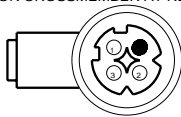
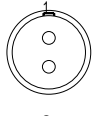



INTERNATIONAL TRUCK AND ENGINE CORPORATION <small>THIS PRINT IS PROVIDED ON A RESTRICTED BASIS AND IS NOT TO BE USED IN ANY WAY DETRIMENTAL TO THE INTEREST OF INTERNATIONAL TRUCK AND ENGINE CORPORATION.</small>		ELECTRICAL CIRCUIT DIAGRAM CHAPTER 14 CONNECTOR BODY COMPOSITE - MATING VIEW SHOWN																																																																				
<p style="text-align: center;">BENDIX LEFT WHEEL SPEED SENSOR (4X2) (9501) (LOCATED ON LEFT FRAME RAIL BY REAR AXLE)</p>  <p style="text-align: center;">CONNECTOR 1684261C1 BODY LOCK 1684263C1</p> <table border="1" style="width:100%; border-collapse: collapse;"> <thead> <tr> <th>CAV</th> <th>CIR</th> <th>GAUGE</th> <th>COLOR</th> <th>TERMINAL</th> <th>SEAL/SLEEVE</th> </tr> </thead> <tbody> <tr> <td>1</td> <td>R94BD</td> <td>16</td> <td>GY</td> <td>1680205C1</td> <td>1652325C1</td> </tr> <tr> <td>2</td> <td>R94BE</td> <td>16</td> <td>GY</td> <td>1680205C1</td> <td>1652325C1</td> </tr> </tbody> </table>	CAV	CIR	GAUGE	COLOR	TERMINAL	SEAL/SLEEVE	1	R94BD	16	GY	1680205C1	1652325C1	2	R94BE	16	GY	1680205C1	1652325C1	<p style="text-align: center;">BENDIX RR LEFT WHEEL SPEED SENSOR (6X4) (9501D) (LOCATED ON LEFT FRAME RAIL BY REAR AXLE) (W/ LONESTAR)</p>  <p style="text-align: center;">CONNECTOR 1684261C1 BODY LOCK 1684263C1</p> <table border="1" style="width:100%; border-collapse: collapse;"> <thead> <tr> <th>CAV</th> <th>CIR</th> <th>GAUGE</th> <th>COLOR</th> <th>TERMINAL</th> </tr> </thead> <tbody> <tr> <td>1*</td> <td>R94BD</td> <td>16</td> <td>GY</td> <td>1680205C1</td> </tr> <tr> <td>1*</td> <td>R94BO</td> <td>16</td> <td>GY</td> <td>1680205C1</td> </tr> <tr> <td>2*</td> <td>R94BE</td> <td>16</td> <td>GY</td> <td>1680205C1</td> </tr> <tr> <td>2*</td> <td>R94BR</td> <td>16</td> <td>GY</td> <td>1680205C1</td> </tr> </tbody> </table> <p style="text-align: center;">* MUTUALLY EXCLUSIVE</p>	CAV	CIR	GAUGE	COLOR	TERMINAL	1*	R94BD	16	GY	1680205C1	1*	R94BO	16	GY	1680205C1	2*	R94BE	16	GY	1680205C1	2*	R94BR	16	GY	1680205C1																										
CAV	CIR	GAUGE	COLOR	TERMINAL	SEAL/SLEEVE																																																																	
1	R94BD	16	GY	1680205C1	1652325C1																																																																	
2	R94BE	16	GY	1680205C1	1652325C1																																																																	
CAV	CIR	GAUGE	COLOR	TERMINAL																																																																		
1*	R94BD	16	GY	1680205C1																																																																		
1*	R94BO	16	GY	1680205C1																																																																		
2*	R94BE	16	GY	1680205C1																																																																		
2*	R94BR	16	GY	1680205C1																																																																		
<p style="text-align: center;">BENDIX LEFT MODULATOR (9502 / #9502A) (LOCATED ON LEFT FRAME RAIL BY REAR AXLE)</p>  <p style="text-align: center;">CONNECTOR 1686834C1 BODY LOCK 1664408C1</p> <table border="1" style="width:100%; border-collapse: collapse;"> <thead> <tr> <th>CAV</th> <th>CIR</th> <th>GAUGE</th> <th>COLOR</th> <th>TERMINAL</th> <th>SEAL/SLEEVE</th> </tr> </thead> <tbody> <tr> <td>A</td> <td>R94BA</td> <td>16</td> <td>GY</td> <td>2033819C1</td> <td>1652325C1</td> </tr> <tr> <td>B</td> <td>R94BB</td> <td>16</td> <td>GY</td> <td>2033819C1</td> <td>1652325C1</td> </tr> <tr> <td>C</td> <td>R94BC</td> <td>16</td> <td>GY</td> <td>2033819C1</td> <td>1652325C1</td> </tr> </tbody> </table> <p style="text-align: center;">(# W/ LONESTAR)</p>	CAV	CIR	GAUGE	COLOR	TERMINAL	SEAL/SLEEVE	A	R94BA	16	GY	2033819C1	1652325C1	B	R94BB	16	GY	2033819C1	1652325C1	C	R94BC	16	GY	2033819C1	1652325C1	<p style="text-align: center;">BENDIX LEFT REAR MODULATOR (9502B) (LOCATED ON LEFT FRAME RAIL BY REAR AXLE) (W/ LONESTAR)</p>  <p style="text-align: center;">* MUTUALLY EXCLUSIVE</p> <p style="text-align: center;">CONNECTOR 1686834C1 BODY LOCK 1664408C1</p> <table border="1" style="width:100%; border-collapse: collapse;"> <thead> <tr> <th>CAV</th> <th>CIR</th> <th>GAUGE</th> <th>COLOR</th> <th>TERMINAL</th> <th>SEAL/SLEEVE</th> </tr> </thead> <tbody> <tr> <td>A*</td> <td>R94BA</td> <td>16</td> <td>GY</td> <td>2033819C1</td> <td>1652325C1</td> </tr> <tr> <td>A*</td> <td>R94BM</td> <td>16</td> <td>GY</td> <td>2033819C1</td> <td>1652325C1</td> </tr> <tr> <td>B*</td> <td>R94BB</td> <td>16</td> <td>GY</td> <td>2033819C1</td> <td>1652325C1</td> </tr> <tr> <td>B*</td> <td>R94BN</td> <td>16</td> <td>GY</td> <td>2033819C1</td> <td>1652325C1</td> </tr> <tr> <td>C*</td> <td>R94BC</td> <td>16</td> <td>GY</td> <td>2033819C1</td> <td>1652325C1</td> </tr> <tr> <td>C*</td> <td>R94BP</td> <td>16</td> <td>GY</td> <td>2033819C1</td> <td>1652325C1</td> </tr> </tbody> </table>	CAV	CIR	GAUGE	COLOR	TERMINAL	SEAL/SLEEVE	A*	R94BA	16	GY	2033819C1	1652325C1	A*	R94BM	16	GY	2033819C1	1652325C1	B*	R94BB	16	GY	2033819C1	1652325C1	B*	R94BN	16	GY	2033819C1	1652325C1	C*	R94BC	16	GY	2033819C1	1652325C1	C*	R94BP	16	GY	2033819C1	1652325C1			
CAV	CIR	GAUGE	COLOR	TERMINAL	SEAL/SLEEVE																																																																	
A	R94BA	16	GY	2033819C1	1652325C1																																																																	
B	R94BB	16	GY	2033819C1	1652325C1																																																																	
C	R94BC	16	GY	2033819C1	1652325C1																																																																	
CAV	CIR	GAUGE	COLOR	TERMINAL	SEAL/SLEEVE																																																																	
A*	R94BA	16	GY	2033819C1	1652325C1																																																																	
A*	R94BM	16	GY	2033819C1	1652325C1																																																																	
B*	R94BB	16	GY	2033819C1	1652325C1																																																																	
B*	R94BN	16	GY	2033819C1	1652325C1																																																																	
C*	R94BC	16	GY	2033819C1	1652325C1																																																																	
C*	R94BP	16	GY	2033819C1	1652325C1																																																																	
<p style="text-align: center;">BENDIX RIGHT WHEEL SPEED SENSOR (9503 / #9503D) (LOCATED ON RIGHT FRAME RAIL BY REAR AXLE)</p>  <p style="text-align: center;">CONNECTOR 1684261C1 BODY LOCK 1684263C1</p> <table border="1" style="width:100%; border-collapse: collapse;"> <thead> <tr> <th>CAV</th> <th>CIR</th> <th>GAUGE</th> <th>COLOR</th> <th>TERMINAL</th> </tr> </thead> <tbody> <tr> <td>1</td> <td>R94BF</td> <td>16</td> <td>GY</td> <td>1680205C1</td> </tr> <tr> <td>1#</td> <td>R94BV</td> <td>16</td> <td>GY</td> <td>1680205C1</td> </tr> <tr> <td>2</td> <td>R94BH</td> <td>16</td> <td>GY</td> <td>1680205C1</td> </tr> <tr> <td>2#</td> <td>R94BW</td> <td>16</td> <td>GY</td> <td>1680205C1</td> </tr> </tbody> </table> <p style="text-align: center;">(# W/ LONESTAR)</p>		CAV	CIR	GAUGE	COLOR	TERMINAL	1	R94BF	16	GY	1680205C1	1#	R94BV	16	GY	1680205C1	2	R94BH	16	GY	1680205C1	2#	R94BW	16	GY	1680205C1	<p style="text-align: center;">BENDIX RR RIGHT MODULATOR (9504 / #9504A / #9504B) (LOCATED ON RIGHT FRAME RAIL BY REAR AXLE)</p>  <p style="text-align: center;">CONNECTOR 1686834C1 BODY LOCK 1664408C1</p> <table border="1" style="width:100%; border-collapse: collapse;"> <thead> <tr> <th>CAV</th> <th>CIR</th> <th>GAUGE</th> <th>COLOR</th> <th>TERMINAL</th> <th>SEAL/SLEEVE</th> </tr> </thead> <tbody> <tr> <td>A</td> <td>R94BJ</td> <td>16</td> <td>GY</td> <td>2033819C1</td> <td>1652325C1</td> </tr> <tr> <td>A#</td> <td>R94BS</td> <td>16</td> <td>GY</td> <td>2033819C1</td> <td>1652325C1</td> </tr> <tr> <td>B</td> <td>R94BK</td> <td>16</td> <td>GY</td> <td>2033819C1</td> <td>1652325C1</td> </tr> <tr> <td>B#</td> <td>R94BT</td> <td>16</td> <td>GY</td> <td>2033819C1</td> <td>1652325C1</td> </tr> <tr> <td>C</td> <td>R94BL</td> <td>16</td> <td>GY</td> <td>2033819C1</td> <td>1652325C1</td> </tr> <tr> <td>C#</td> <td>R94BU</td> <td>16</td> <td>GY</td> <td>2033819C1</td> <td>1652325C1</td> </tr> </tbody> </table> <p style="text-align: center;">(# W/ LONESTAR)</p>		CAV	CIR	GAUGE	COLOR	TERMINAL	SEAL/SLEEVE	A	R94BJ	16	GY	2033819C1	1652325C1	A#	R94BS	16	GY	2033819C1	1652325C1	B	R94BK	16	GY	2033819C1	1652325C1	B#	R94BT	16	GY	2033819C1	1652325C1	C	R94BL	16	GY	2033819C1	1652325C1	C#	R94BU	16	GY	2033819C1	1652325C1
CAV	CIR	GAUGE	COLOR	TERMINAL																																																																		
1	R94BF	16	GY	1680205C1																																																																		
1#	R94BV	16	GY	1680205C1																																																																		
2	R94BH	16	GY	1680205C1																																																																		
2#	R94BW	16	GY	1680205C1																																																																		
CAV	CIR	GAUGE	COLOR	TERMINAL	SEAL/SLEEVE																																																																	
A	R94BJ	16	GY	2033819C1	1652325C1																																																																	
A#	R94BS	16	GY	2033819C1	1652325C1																																																																	
B	R94BK	16	GY	2033819C1	1652325C1																																																																	
B#	R94BT	16	GY	2033819C1	1652325C1																																																																	
C	R94BL	16	GY	2033819C1	1652325C1																																																																	
C#	R94BU	16	GY	2033819C1	1652325C1																																																																	
<table border="1" style="width:100%; border-collapse: collapse;"> <thead> <tr> <th>CHK</th> <th>DATE</th> <th>CHANGE</th> <th>REV</th> <th>REFERENCE</th> <th>DRAWN</th> <th>NAME</th> </tr> </thead> <tbody> <tr> <td>CNA1</td> <td>14JAN09</td> <td>ADDED LONESTAR EFFECT</td> <td>A</td> <td>61254R</td> <td>U00K640</td> <td>CIRCUIT DIAGRAM, PROSTAR, LONESTAR</td> </tr> </tbody> </table>		CHK	DATE	CHANGE	REV	REFERENCE	DRAWN	NAME	CNA1	14JAN09	ADDED LONESTAR EFFECT	A	61254R	U00K640	CIRCUIT DIAGRAM, PROSTAR, LONESTAR	<table border="1" style="width:100%; border-collapse: collapse;"> <thead> <tr> <th>RELEASE NO.</th> <th>DATE</th> <th>PART NO.</th> <th>SHEET</th> </tr> </thead> <tbody> <tr> <td>59637L</td> <td>11SEP06</td> <td>AE08055906</td> <td>112</td> </tr> </tbody> </table>		RELEASE NO.	DATE	PART NO.	SHEET	59637L	11SEP06	AE08055906	112																																													
CHK	DATE	CHANGE	REV	REFERENCE	DRAWN	NAME																																																																
CNA1	14JAN09	ADDED LONESTAR EFFECT	A	61254R	U00K640	CIRCUIT DIAGRAM, PROSTAR, LONESTAR																																																																
RELEASE NO.	DATE	PART NO.	SHEET																																																																			
59637L	11SEP06	AE08055906	112																																																																			

Figure 374 Connector Composites (9501), (9501D), (9502/9502A), (9502B), (9503/9503D), (9504/9504A/9504B)

**14.146. CONNECTOR COMPOSITES (9505/9505A), (9506/9506D/9506E), (9507/9507A/9507B), (9508/9508B/9508D/9508E), (9509/9509A/9509B), P. 113**

<p>INTERNATIONAL TRUCK AND ENGINE CORPORATION</p> <p style="font-size: small;">THIS PRINT IS PROVIDED ON A RESTRICTED BASIS AND IS NOT TO BE USED IN ANY WAY DETRIMENTAL TO THE INTEREST OF INTERNATIONAL TRUCK AND ENGINE CORPORATION.</p>	<p>ELECTRICAL CIRCUIT DIAGRAM CHAPTER 14</p> <p>CONNECTOR BODY COMPOSITE - MATING VIEW SHOWN</p>																												
<p>BENDIX AUTO TRACTION CONTROL (9505 / *9505A) (LOCATED ON CROSSMEMBER AT REAR AXLE(S))</p>  <p>CONNECTOR 3518183C1 BODY LOCK 3518174C1</p>	<table border="1" style="width:100%; border-collapse: collapse;"> <thead> <tr> <th>CAV</th> <th>CIR</th> <th>GAUGE</th> <th>COLOR</th> <th>TERMINAL</th> </tr> </thead> <tbody> <tr> <td>1</td> <td>R94BM</td> <td>16</td> <td>GY</td> <td>3518961C1</td> </tr> <tr> <td>2</td> <td>R94BN</td> <td>16</td> <td>GY</td> <td>3518961C1</td> </tr> <tr> <td>3</td> <td>-</td> <td>-</td> <td>-</td> <td>-</td> </tr> </tbody> </table> <p>(* W/ LONESTAR)</p>	CAV	CIR	GAUGE	COLOR	TERMINAL	1	R94BM	16	GY	3518961C1	2	R94BN	16	GY	3518961C1	3	-	-	-	-								
CAV	CIR	GAUGE	COLOR	TERMINAL																									
1	R94BM	16	GY	3518961C1																									
2	R94BN	16	GY	3518961C1																									
3	-	-	-	-																									
<p>WABCO LEFT WHEEL SPEED SENSOR (9506 / *9506D / *9506E) (LOCATED ON LEFT FRAME RAIL BY REAR AXLE)</p>  <p>CONNECTOR 3519878C1</p>	<table border="1" style="width:100%; border-collapse: collapse;"> <thead> <tr> <th>CAV</th> <th>CIR</th> <th>GAUGE</th> <th>COLOR</th> <th>TERMINAL</th> </tr> </thead> <tbody> <tr> <td>1</td> <td>R94MBD</td> <td>18</td> <td>GY</td> <td>ASSY</td> </tr> <tr> <td>2</td> <td>R94MBE</td> <td>18</td> <td>GY</td> <td>ASSY</td> </tr> </tbody> </table> <p>(* W/ LONESTAR)</p>	CAV	CIR	GAUGE	COLOR	TERMINAL	1	R94MBD	18	GY	ASSY	2	R94MBE	18	GY	ASSY													
CAV	CIR	GAUGE	COLOR	TERMINAL																									
1	R94MBD	18	GY	ASSY																									
2	R94MBE	18	GY	ASSY																									
<p>WABCO LEFT MODULATOR (9507 / *9507A / * 9507B) (LOCATED ON LEFT FRAME RAIL BY REAR AXLE)</p>  <p>CONNECTOR 3667691C1</p>	<table border="1" style="width:100%; border-collapse: collapse;"> <thead> <tr> <th>CAV</th> <th>CIR</th> <th>GAUGE</th> <th>COLOR</th> <th>TERMINAL</th> </tr> </thead> <tbody> <tr> <td>1</td> <td>R94MBA</td> <td>18</td> <td>GY</td> <td>ASSY</td> </tr> <tr> <td>2</td> <td>R94MBB</td> <td>18</td> <td>GY</td> <td>ASSY</td> </tr> <tr> <td>3</td> <td>R94MBC</td> <td>18</td> <td>GY</td> <td>ASSY</td> </tr> </tbody> </table> <p>(* W/ LONESTAR)</p>	CAV	CIR	GAUGE	COLOR	TERMINAL	1	R94MBA	18	GY	ASSY	2	R94MBB	18	GY	ASSY	3	R94MBC	18	GY	ASSY								
CAV	CIR	GAUGE	COLOR	TERMINAL																									
1	R94MBA	18	GY	ASSY																									
2	R94MBB	18	GY	ASSY																									
3	R94MBC	18	GY	ASSY																									
<p>WABCO RIGHT WHEEL SPEED SENSOR (9508 / *9508B / *9508D / *9508E) (LOCATED ON RIGHT FRAME RAIL BY REAR AXLE)</p>  <p>CONNECTOR 3519878C1</p>	<table border="1" style="width:100%; border-collapse: collapse;"> <thead> <tr> <th>CAV</th> <th>CIR</th> <th>GAUGE</th> <th>COLOR</th> <th>TERMINAL</th> </tr> </thead> <tbody> <tr> <td>1</td> <td>R94MBF</td> <td>18</td> <td>GY</td> <td>ASSY</td> </tr> <tr> <td>2</td> <td>R94MBH</td> <td>18</td> <td>GY</td> <td>ASSY</td> </tr> </tbody> </table> <p>(* W/ LONESTAR)</p>	CAV	CIR	GAUGE	COLOR	TERMINAL	1	R94MBF	18	GY	ASSY	2	R94MBH	18	GY	ASSY													
CAV	CIR	GAUGE	COLOR	TERMINAL																									
1	R94MBF	18	GY	ASSY																									
2	R94MBH	18	GY	ASSY																									
<p>WABCO RIGHT WHEEL MODULATOR (9509 / *9509A / *9509B) (LOCATED ON RIGHT FRAME RAIL BY REAR AXLE)</p>  <p>CONNECTOR 3667691C1</p>	<table border="1" style="width:100%; border-collapse: collapse;"> <thead> <tr> <th>CAV</th> <th>CIR</th> <th>GAUGE</th> <th>COLOR</th> <th>TERMINAL</th> </tr> </thead> <tbody> <tr> <td>1</td> <td>R94MBJ</td> <td>18</td> <td>GY</td> <td>ASSY</td> </tr> <tr> <td>2</td> <td>R94MBK</td> <td>18</td> <td>GY</td> <td>ASSY</td> </tr> <tr> <td>3</td> <td>R94MBL</td> <td>18</td> <td>GY</td> <td>ASSY</td> </tr> </tbody> </table> <p>(* W/ LONESTAR)</p>	CAV	CIR	GAUGE	COLOR	TERMINAL	1	R94MBJ	18	GY	ASSY	2	R94MBK	18	GY	ASSY	3	R94MBL	18	GY	ASSY								
CAV	CIR	GAUGE	COLOR	TERMINAL																									
1	R94MBJ	18	GY	ASSY																									
2	R94MBK	18	GY	ASSY																									
3	R94MBL	18	GY	ASSY																									
<table border="1" style="width:100%; border-collapse: collapse;"> <thead> <tr> <th>CHK</th> <th>DATE</th> <th>CHANGE</th> <th>REV</th> <th>REFERENCE</th> <th>DRAWN</th> <th>NAME</th> </tr> </thead> <tbody> <tr> <td>CNA1</td> <td>14JAN09</td> <td>ADDED LONESTAR EFFECT</td> <td>B</td> <td>61254R</td> <td>U00K640</td> <td>CIRCUIT DIAGRAM, PROSTAR, LONESTAR</td> </tr> <tr> <td></td> <td></td> <td></td> <td></td> <td></td> <td>RELEASE NO.</td> <td>DATE</td> </tr> <tr> <td></td> <td></td> <td></td> <td></td> <td></td> <td>59637L</td> <td>11SEP06</td> </tr> </tbody> </table>		CHK	DATE	CHANGE	REV	REFERENCE	DRAWN	NAME	CNA1	14JAN09	ADDED LONESTAR EFFECT	B	61254R	U00K640	CIRCUIT DIAGRAM, PROSTAR, LONESTAR						RELEASE NO.	DATE						59637L	11SEP06
CHK	DATE	CHANGE	REV	REFERENCE	DRAWN	NAME																							
CNA1	14JAN09	ADDED LONESTAR EFFECT	B	61254R	U00K640	CIRCUIT DIAGRAM, PROSTAR, LONESTAR																							
					RELEASE NO.	DATE																							
					59637L	11SEP06																							
<p>PART NO. <b>AE08055906</b> SHEET <b>113</b></p>																													

**Figure 375 Connector Composites (9505/9505A), (9506/9506D/9506E), (9507/9507A/9507B), (9508/9508B/9508D/9508E), (9509/9509A/9509B)**

14.147. CONNECTOR COMPOSITES (9510/9510A/9510F), (9510F/9510M), (9511), (9511/9511A), (9512), P. 114

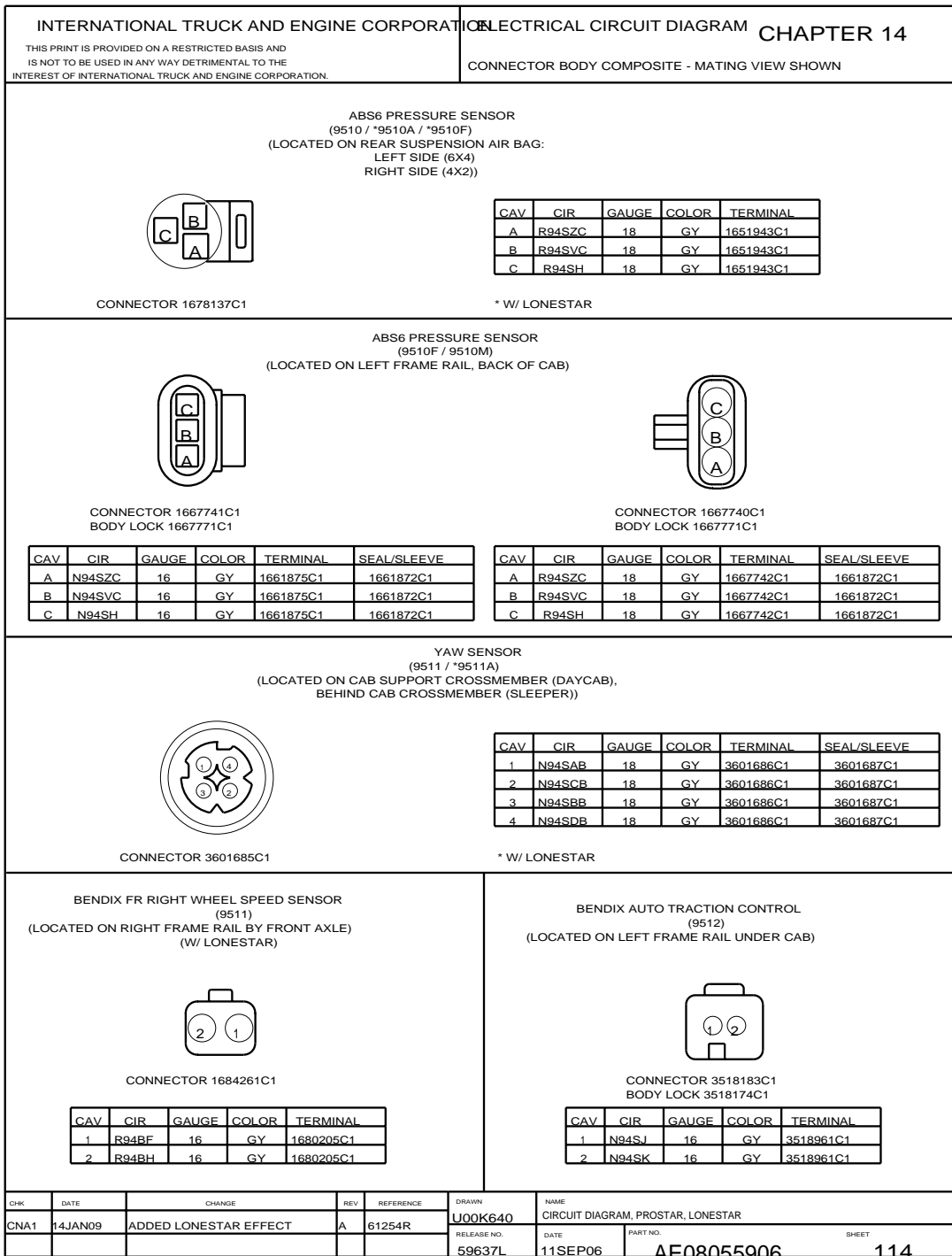


Figure 376 Connector Composites (9510/9510A/9510F), (9510F/9510M), (9511), (9511/9511A), (9512)

14.148. CONNECTOR COMPOSITES (9512), (9513), (9514), (9515/9515A/9515B), P. 115

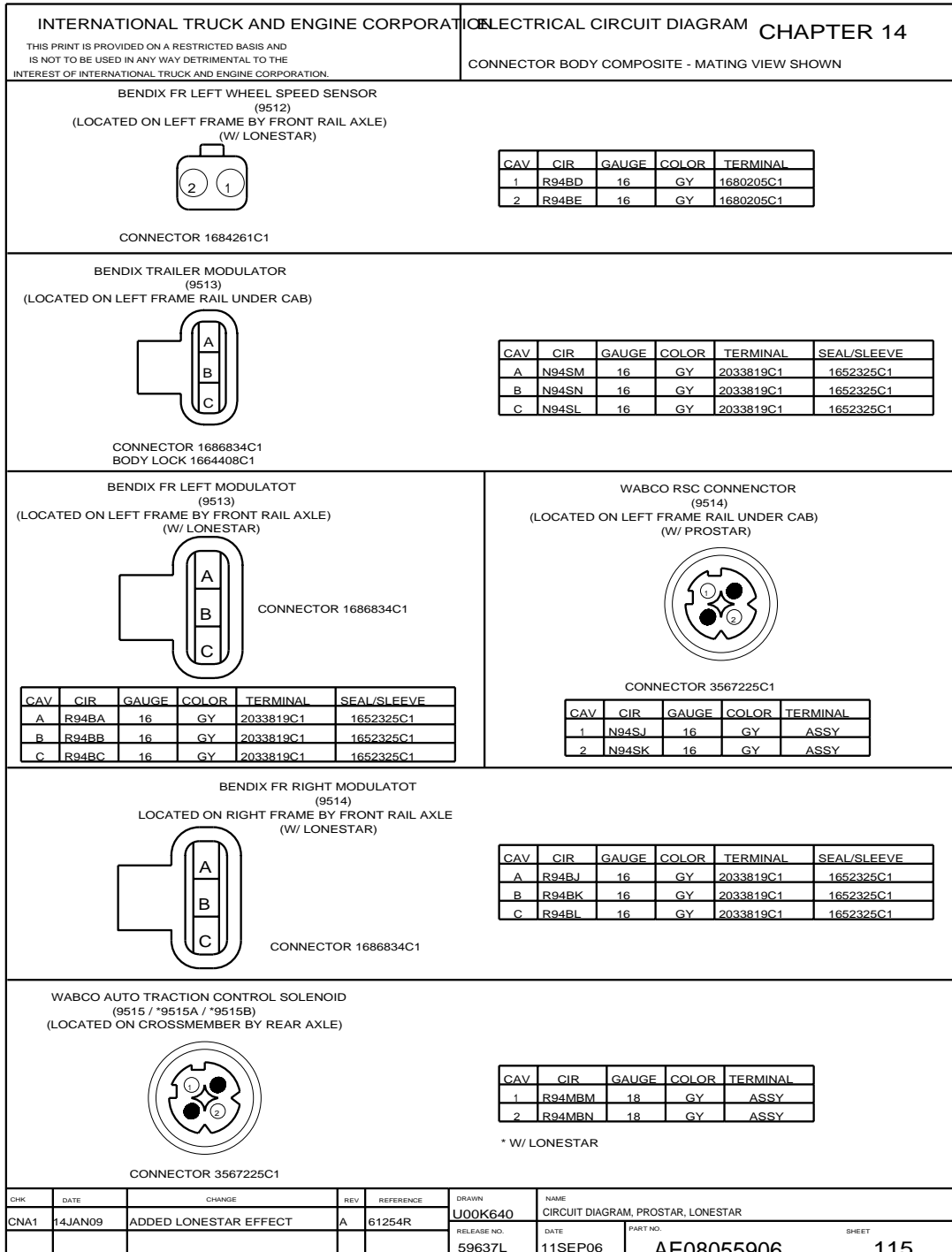
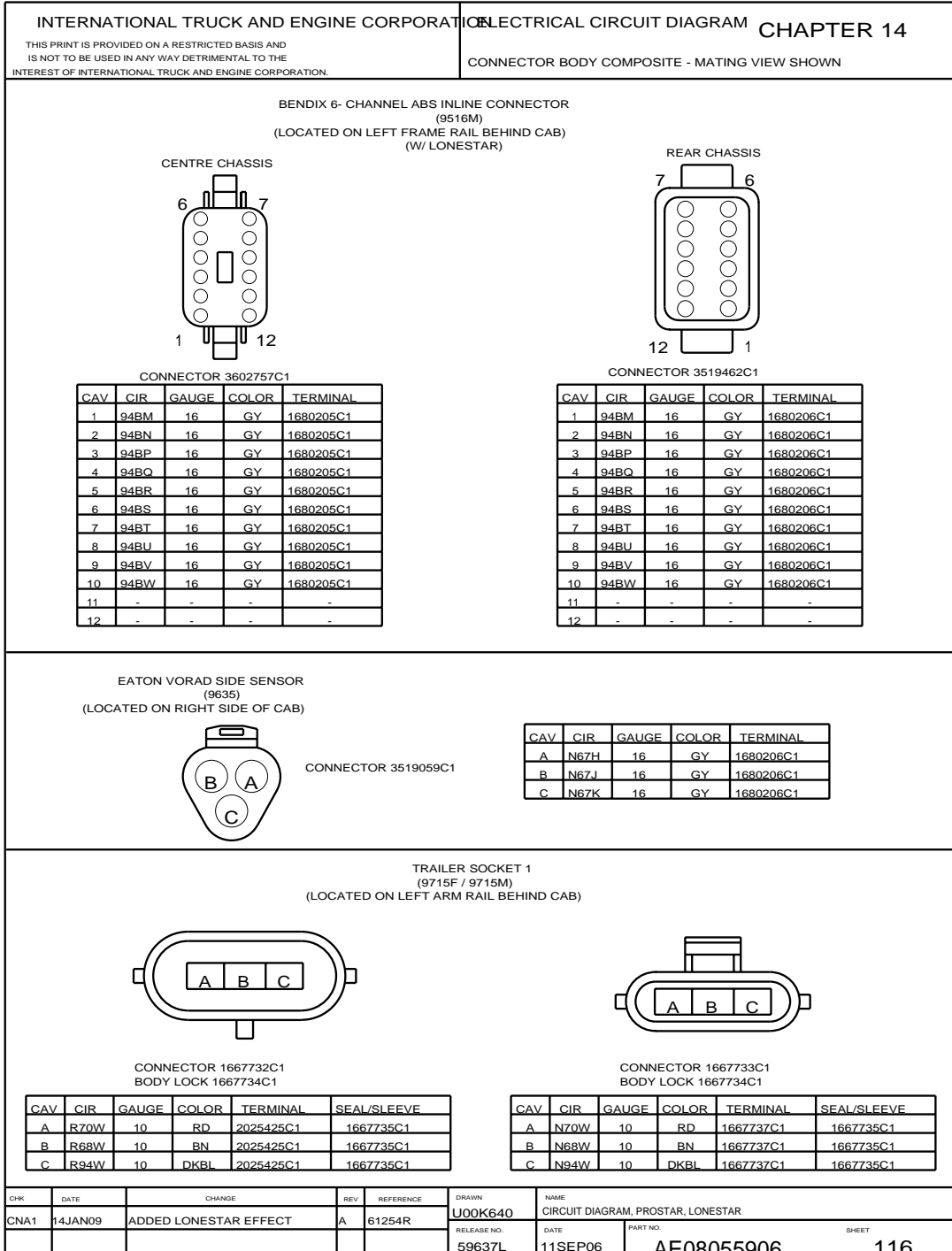


Figure 377 Connector Composites (9512), (9513), (9514), (9515/9515A/9515B)

14.149. CONNECTOR COMPOSITES (9516M), (9635), (9715F/9715M), P. 116



TRAILER SOCKET 1  
(9715F / 9715M)  
(LOCATED ON LEFT ARM RAIL BEHIND CAB)

CAV	CIR	GAUGE	COLOR	TERMINAL	SEAL/SLEEVE
A	R70W	10	RD	2025425C1	1667735C1
B	R68W	10	BN	2025425C1	1667735C1
C	R94W	10	DKBL	2025425C1	1667735C1

CAV	CIR	GAUGE	COLOR	TERMINAL	SEAL/SLEEVE
A	N70W	10	RD	1667737C1	1667735C1
B	N68W	10	BN	1667737C1	1667735C1
C	N94W	10	DKBL	1667737C1	1667735C1

Figure 378 Connector Composites (9516M), (9635), (9715F/9715M)

14.150. CONNECTOR COMPOSITES (9716M/9716F), (9718), (9736), (9737), P. 117

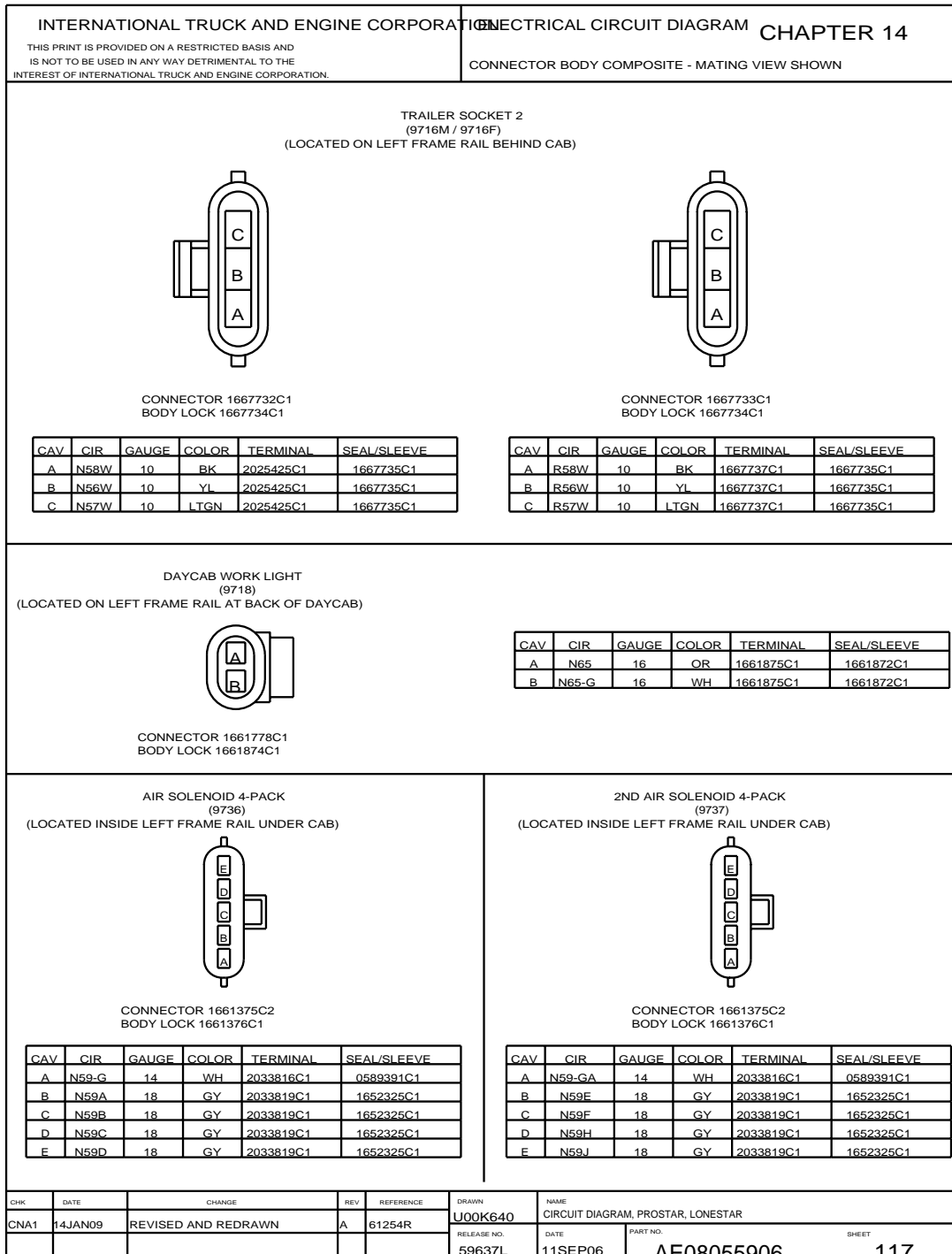


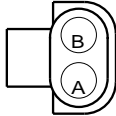
Figure 379 Connector Composites (9716M/9716F), (9718), (9736), (9737)

14.151. CONNECTOR COMPOSITES (9738), (9768), (9769), P. 118

<p>INTERNATIONAL TRUCK AND ENGINE CORPORATION</p> <p>THIS PRINT IS PROVIDED ON A RESTRICTED BASIS AND IS NOT TO BE USED IN ANY WAY DETRIMENTAL TO THE INTEREST OF INTERNATIONAL TRUCK AND ENGINE CORPORATION.</p>	<p>ELECTRICAL CIRCUIT DIAGRAM CHAPTER 14</p> <p>CONNECTOR BODY COMPOSITE - MATING VIEW SHOWN</p>
---	--

5TH WHEEL JAW LOCK SOLENOID (9738)  
(LOCATED AT END OF FRAME - LEFT SIDE)



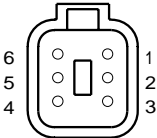
CONNECTOR 0587568C91

\* W/ ONE SOLENOID 4 PACK W/ CNT = 3  
# W/ ONE SOLENOID 4 PACK W/ CNT = 4  
\*\* W/ TWO SOLENOID 4 PACK W/ CNT = 6  
## W/ TWO SOLENOID 4 PACK W/ CNT = 5  
& W/ TWO SOLENOID 4 PACK W/ CNT = 7

CAV	CIR	GAUGE	COLOR	TERMINAL	SEAL/SLEEVE
A*	N59K	16	GY	0587575C1	1652325C1
A#	N59K	18	GY	0587576C1	1652325C1
A**	N59K	18	GY	0587576C1	1652325C1
A##	N59K	16	GY	0587575C1	1652325C1
A&	N59K	16	GY	0587575C1	1652325C1
B	N59-GB	16	WH	0587575C1	1652325C1

EATON VORAD VS-400 (9768)  
(LOCATED ON RIGHT SIDE CAB)




CONNECTOR 3673640C1  
BODY LOCK 2005243C1

CAV	CIR	GAUGE	COLOR	TERMINAL
1	N67TA	16	PK	3572626C1
2	N67GU	16	WH	3572626C1
3	N67U	16	GY	3572626C1
4	N67V	16	GY	3572626C1
5	N67W	16	GY	3572626C1
6	PLUG	-	-	0453133C1

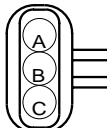
J1939 CENTER CHASSIS TO FWD CHASSIS (9769)  
(LOCATED ON LEFT SIDE DASH PANEL)



CONNECTOR 1667741C1  
BODY LOCK 1667771C1

CAV	CIR	GAUGE	COLOR	TERMINAL	SEAL/SLEEVE
A	M5U(+)	18	YL	1661875C1	3568570C1
A%%	M5UK(+)	18	YL	1661875C1	3568570C1
B	-	-	-	-	-
C	M5U(-)	18	GN	1661875C1	3568570C1
C%%	M5UK(-)	18	GN	1661875C1	3568570C1

%% W/ WABCO ONGUARD



CONNECTOR 1667740C1  
BODY LOCK 1667771C1

CAV	CIR	GAUGE	COLOR	TERMINAL	SEAL/SLEEVE
A	N5U(+)	18	YL	1667742C1	3568570C1
B	-	-	-	-	-
C	N5U(-)	18	GN	1667742C1	3568570C1

CHK	DATE	CHANGE	REV	REFERENCE	DRAWN	NAME
CNA1	07OCT09	W484//ADDED WABCO	C	62556A	U00K640	CIRCUIT DIAGRAM, PROSTAR, LONESTAR
	ONGUARD				59637L	11SEP06

	PART NO.	AE08055906	SHEET	118
--	----------	------------	-------	-----

Figure 380 Connector Composites (9738), (9768), (9769)

**14.152. CONNECTOR COMPOSITES (9770), (9779/9779F/9779FA), (9779F1), (9780/9780M), (9780M1), P. 119**

<p>INTERNATIONAL TRUCK AND ENGINE CORPORATION</p> <p>THIS PRINT IS PROVIDED ON A RESTRICTED BASIS AND IS NOT TO BE USED IN ANY WAY DETRIMENTAL TO THE INTEREST OF INTERNATIONAL TRUCK AND ENGINE CORPORATION.</p>	<p>ELECTRICAL CIRCUIT DIAGRAM CHAPTER 14</p> <p>CONNECTOR BODY COMPOSITE - MATING VIEW SHOWN</p>																																																																								
<p>J1939 CENTER CHASSIS TO FWD CHASSIS (9770) (LOCATED INSIDE LEFT FRAME RAIL UNDER CAB)</p>																																																																									
<p>CONNECTOR 1667741C1 BODY LOCK 1667771C1</p>	<p>CONNECTOR 1667733C1 *CONNECTOR 1667740C1 BODY LOCK 1667771C1</p>																																																																								
<table border="1" style="width:100%; border-collapse: collapse;"> <thead> <tr> <th>CAV</th> <th>CIRC</th> <th>GA</th> <th>COLOR</th> <th>TERMINAL</th> <th>SEAL/SLEEVE</th> </tr> </thead> <tbody> <tr> <td>A</td> <td>M5UB(+)</td> <td>18</td> <td>YL</td> <td>1661875C1</td> <td>3568570C1</td> </tr> <tr> <td>A%#</td> <td>M5UH(+)</td> <td>18</td> <td>YL</td> <td>1661875C1</td> <td>3568570C1</td> </tr> <tr> <td>B</td> <td>PLUG</td> <td>-</td> <td>-</td> <td>-</td> <td>2025431C1</td> </tr> <tr> <td>C</td> <td>M5UB(-)</td> <td>18</td> <td>GN</td> <td>1661875C1</td> <td>3568570C1</td> </tr> <tr> <td>C%#</td> <td>M5UH(-)</td> <td>18</td> <td>GN</td> <td>1661875C1</td> <td>3568570C1</td> </tr> </tbody> </table>	CAV	CIRC	GA	COLOR	TERMINAL	SEAL/SLEEVE	A	M5UB(+)	18	YL	1661875C1	3568570C1	A%#	M5UH(+)	18	YL	1661875C1	3568570C1	B	PLUG	-	-	-	2025431C1	C	M5UB(-)	18	GN	1661875C1	3568570C1	C%#	M5UH(-)	18	GN	1661875C1	3568570C1	<table border="1" style="width:100%; border-collapse: collapse;"> <thead> <tr> <th>CAV</th> <th>CIRC</th> <th>GA</th> <th>COLOR</th> <th>TERMINAL</th> <th>SEAL/SLEEVE</th> </tr> </thead> <tbody> <tr> <td>A</td> <td>N5UB(+)</td> <td>18</td> <td>YL</td> <td>1667742C1</td> <td>3568570C1</td> </tr> <tr> <td>B</td> <td>PLUG</td> <td>-</td> <td>-</td> <td>-</td> <td>2025431C1</td> </tr> <tr> <td>C</td> <td>N5UB(-)</td> <td>18</td> <td>GN</td> <td>1667742C1</td> <td>3568570C1</td> </tr> </tbody> </table>	CAV	CIRC	GA	COLOR	TERMINAL	SEAL/SLEEVE	A	N5UB(+)	18	YL	1667742C1	3568570C1	B	PLUG	-	-	-	2025431C1	C	N5UB(-)	18	GN	1667742C1	3568570C1												
CAV	CIRC	GA	COLOR	TERMINAL	SEAL/SLEEVE																																																																				
A	M5UB(+)	18	YL	1661875C1	3568570C1																																																																				
A%#	M5UH(+)	18	YL	1661875C1	3568570C1																																																																				
B	PLUG	-	-	-	2025431C1																																																																				
C	M5UB(-)	18	GN	1661875C1	3568570C1																																																																				
C%#	M5UH(-)	18	GN	1661875C1	3568570C1																																																																				
CAV	CIRC	GA	COLOR	TERMINAL	SEAL/SLEEVE																																																																				
A	N5UB(+)	18	YL	1667742C1	3568570C1																																																																				
B	PLUG	-	-	-	2025431C1																																																																				
C	N5UB(-)	18	GN	1667742C1	3568570C1																																																																				
<p>%% W/ WABCO ONGUARD (* W/ LONESTAR)</p>																																																																									
<p>DAYCAB TRAILER SOCKET # 2 (9779 / @9779F / @9779FA) (LOCATED AT BOTTOM OF DASH PANEL - LEFT SIDE)</p> <p>CONNECTOR 1667732C1 BODY LOCK 1667734C1</p> <table border="1" style="width:100%; border-collapse: collapse;"> <thead> <tr> <th>CAV</th> <th>CIR</th> <th>GAUGE</th> <th>COLOR</th> <th>TERMINAL</th> <th>SEAL/SLEEVE</th> </tr> </thead> <tbody> <tr> <td>A*</td> <td>N58U</td> <td>10</td> <td>BK</td> <td>2025425C1</td> <td>1667735C1</td> </tr> <tr> <td>A#</td> <td>N58T</td> <td>10</td> <td>BK</td> <td>2025425C1</td> <td>1667735C1</td> </tr> <tr> <td>B*</td> <td>N56U</td> <td>10</td> <td>YL</td> <td>2025425C1</td> <td>1667735C1</td> </tr> <tr> <td>B#</td> <td>N56T</td> <td>10</td> <td>YL</td> <td>2025425C1</td> <td>1667735C1</td> </tr> <tr> <td>C*</td> <td>N57U</td> <td>10</td> <td>LTGN</td> <td>2025425C1</td> <td>1667735C1</td> </tr> <tr> <td>C#</td> <td>N57T</td> <td>10</td> <td>LTGN</td> <td>2025425C1</td> <td>1667735C1</td> </tr> </tbody> </table> <p>* TRAILER SOCKET W/ BOC &amp; EOF # TRAILER SOCKET W/ BOC @ W/ LONESTAR</p>	CAV	CIR	GAUGE	COLOR	TERMINAL	SEAL/SLEEVE	A*	N58U	10	BK	2025425C1	1667735C1	A#	N58T	10	BK	2025425C1	1667735C1	B*	N56U	10	YL	2025425C1	1667735C1	B#	N56T	10	YL	2025425C1	1667735C1	C*	N57U	10	LTGN	2025425C1	1667735C1	C#	N57T	10	LTGN	2025425C1	1667735C1	<p>TRAMEC TRAILER SOCKET #12 (9779F1) (LOCATED AT BOTTOM OF DASH PANEL - LEFT SIDE) (W/ LONESTAR)</p> <p>CONNECTOR 1667732C1 BODY LOCK 1667734C1</p> <table border="1" style="width:100%; border-collapse: collapse;"> <thead> <tr> <th>CAV</th> <th>CIRC</th> <th>GA</th> <th>COLOR</th> <th>TERMINAL</th> <th>SEAL/SLEEVE</th> </tr> </thead> <tbody> <tr> <td>A</td> <td>N58T</td> <td>10</td> <td>BR</td> <td>2025425C1</td> <td>1667735C1</td> </tr> <tr> <td>B</td> <td>N56T</td> <td>10</td> <td>YL</td> <td>2025425C1</td> <td>1667735C1</td> </tr> <tr> <td>C</td> <td>N57T</td> <td>10</td> <td>LTGN</td> <td>2025425C1</td> <td>1667735C1</td> </tr> </tbody> </table>	CAV	CIRC	GA	COLOR	TERMINAL	SEAL/SLEEVE	A	N58T	10	BR	2025425C1	1667735C1	B	N56T	10	YL	2025425C1	1667735C1	C	N57T	10	LTGN	2025425C1	1667735C1						
CAV	CIR	GAUGE	COLOR	TERMINAL	SEAL/SLEEVE																																																																				
A*	N58U	10	BK	2025425C1	1667735C1																																																																				
A#	N58T	10	BK	2025425C1	1667735C1																																																																				
B*	N56U	10	YL	2025425C1	1667735C1																																																																				
B#	N56T	10	YL	2025425C1	1667735C1																																																																				
C*	N57U	10	LTGN	2025425C1	1667735C1																																																																				
C#	N57T	10	LTGN	2025425C1	1667735C1																																																																				
CAV	CIRC	GA	COLOR	TERMINAL	SEAL/SLEEVE																																																																				
A	N58T	10	BR	2025425C1	1667735C1																																																																				
B	N56T	10	YL	2025425C1	1667735C1																																																																				
C	N57T	10	LTGN	2025425C1	1667735C1																																																																				
<p>DAYCAB TRAILER SOCKET # 1 (9780 / 9780M) (LOCATED AT BOTTOM OF DASH PANEL - LEFT SIDE)</p> <p>CONNECTOR 3535482C1 BODY LOCK 3535483C1</p> <table border="1" style="width:100%; border-collapse: collapse;"> <thead> <tr> <th>CAV</th> <th>CIR</th> <th>GAUGE</th> <th>COLOR</th> <th>TERMINAL</th> <th>SEAL/SLEEVE</th> </tr> </thead> <tbody> <tr> <td>A#</td> <td>N94U</td> <td>10</td> <td>DKBL</td> <td>1687847C1</td> <td>0589390C1</td> </tr> <tr> <td>A*</td> <td>N94T</td> <td>10</td> <td>DKBL</td> <td>1687847C1</td> <td>0589390C1</td> </tr> <tr> <td>B#</td> <td>N68U</td> <td>10</td> <td>BN</td> <td>1687847C1</td> <td>0589390C1</td> </tr> <tr> <td>B*</td> <td>N68T</td> <td>10</td> <td>BN</td> <td>1687847C1</td> <td>0589390C1</td> </tr> <tr> <td>C#</td> <td>N70U</td> <td>10</td> <td>RD</td> <td>1687847C1</td> <td>0589390C1</td> </tr> <tr> <td>C*</td> <td>N70T</td> <td>10</td> <td>RD</td> <td>1687847C1</td> <td>0589390C1</td> </tr> <tr> <td>D</td> <td>N72V</td> <td>12</td> <td>DKBL</td> <td>2033816C1</td> <td>0589390C1</td> </tr> </tbody> </table> <p>* TRAILER SOCKET W/ BOC # TRAILER SOCKET W/ BOC &amp; EOF</p>	CAV	CIR	GAUGE	COLOR	TERMINAL	SEAL/SLEEVE	A#	N94U	10	DKBL	1687847C1	0589390C1	A*	N94T	10	DKBL	1687847C1	0589390C1	B#	N68U	10	BN	1687847C1	0589390C1	B*	N68T	10	BN	1687847C1	0589390C1	C#	N70U	10	RD	1687847C1	0589390C1	C*	N70T	10	RD	1687847C1	0589390C1	D	N72V	12	DKBL	2033816C1	0589390C1	<p>TRAMEC TRAILER SOCKET #1 (9780M1) (LOCATED AT BOTTOM OF DASH PANEL - LEFT SIDE) (W/ LONESTAR)</p> <p>CONNECTOR 1667740C1 BODY LOCK 1667771C1</p> <table border="1" style="width:100%; border-collapse: collapse;"> <thead> <tr> <th>CAV</th> <th>CIR</th> <th>GAUGE</th> <th>COLOR</th> <th>TERMINAL</th> <th>SEAL/SLEEVE</th> </tr> </thead> <tbody> <tr> <td>A</td> <td>N94T</td> <td>10</td> <td>DKBL</td> <td>1667737C1</td> <td>1667735C1</td> </tr> <tr> <td>B</td> <td>N68T</td> <td>10</td> <td>BN</td> <td>1667737C1</td> <td>1667735C1</td> </tr> <tr> <td>C</td> <td>N70T</td> <td>10</td> <td>RD</td> <td>1667737C1</td> <td>1667735C1</td> </tr> </tbody> </table>	CAV	CIR	GAUGE	COLOR	TERMINAL	SEAL/SLEEVE	A	N94T	10	DKBL	1667737C1	1667735C1	B	N68T	10	BN	1667737C1	1667735C1	C	N70T	10	RD	1667737C1	1667735C1
CAV	CIR	GAUGE	COLOR	TERMINAL	SEAL/SLEEVE																																																																				
A#	N94U	10	DKBL	1687847C1	0589390C1																																																																				
A*	N94T	10	DKBL	1687847C1	0589390C1																																																																				
B#	N68U	10	BN	1687847C1	0589390C1																																																																				
B*	N68T	10	BN	1687847C1	0589390C1																																																																				
C#	N70U	10	RD	1687847C1	0589390C1																																																																				
C*	N70T	10	RD	1687847C1	0589390C1																																																																				
D	N72V	12	DKBL	2033816C1	0589390C1																																																																				
CAV	CIR	GAUGE	COLOR	TERMINAL	SEAL/SLEEVE																																																																				
A	N94T	10	DKBL	1667737C1	1667735C1																																																																				
B	N68T	10	BN	1667737C1	1667735C1																																																																				
C	N70T	10	RD	1667737C1	1667735C1																																																																				
<table border="1" style="width:100%; border-collapse: collapse;"> <tr> <th>CHK</th> <th>DATE</th> <th>CHANGE</th> <th>REV</th> <th>REFERENCE</th> <th>DRAWN</th> <th>NAME</th> </tr> <tr> <td>CNA1</td> <td>07OCT09</td> <td>W484//ADDED WABCO</td> <td>D</td> <td>62556A</td> <td>U00K640</td> <td>CIRCUIT DIAGRAM, PROSTAR, LONESTAR</td> </tr> <tr> <td></td> <td>ONGUARD.</td> <td></td> <td></td> <td></td> <td>RELEASE NO. 59637L</td> <td>DATE 11SEP06</td> </tr> </table>		CHK	DATE	CHANGE	REV	REFERENCE	DRAWN	NAME	CNA1	07OCT09	W484//ADDED WABCO	D	62556A	U00K640	CIRCUIT DIAGRAM, PROSTAR, LONESTAR		ONGUARD.				RELEASE NO. 59637L	DATE 11SEP06																																																			
CHK	DATE	CHANGE	REV	REFERENCE	DRAWN	NAME																																																																			
CNA1	07OCT09	W484//ADDED WABCO	D	62556A	U00K640	CIRCUIT DIAGRAM, PROSTAR, LONESTAR																																																																			
	ONGUARD.				RELEASE NO. 59637L	DATE 11SEP06																																																																			
<p>PART NO. <b>AE08055906</b> SHEET <b>119</b></p>																																																																									

Figure 381 Connector Composites (9770), (9779/9779F/9779FA), (9779F1), (9780/9780M), (9780M1)

14.153. CONNECTOR COMPOSITES (9781F), (9782M), (9783F), (9783M), (9784M), P. 120

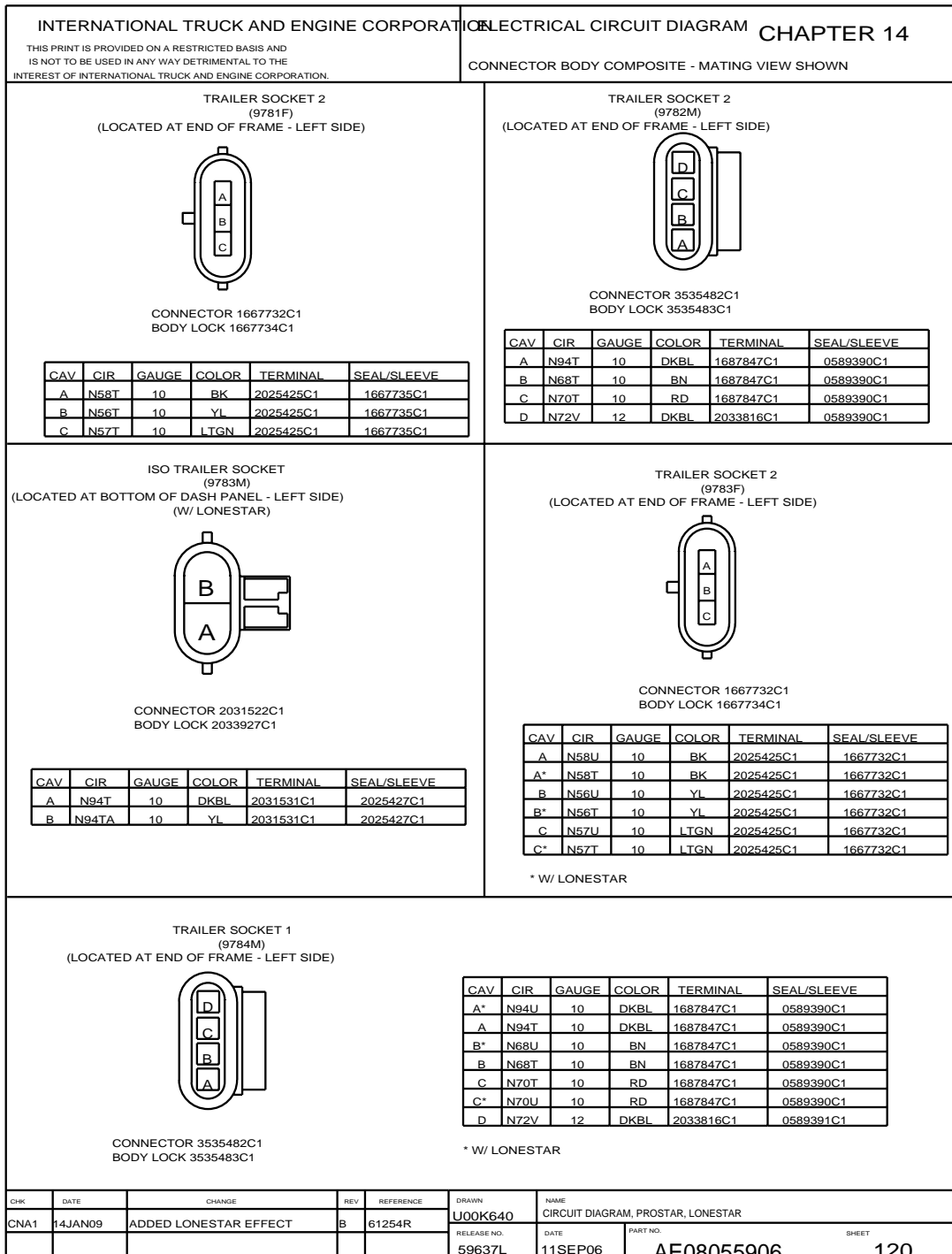
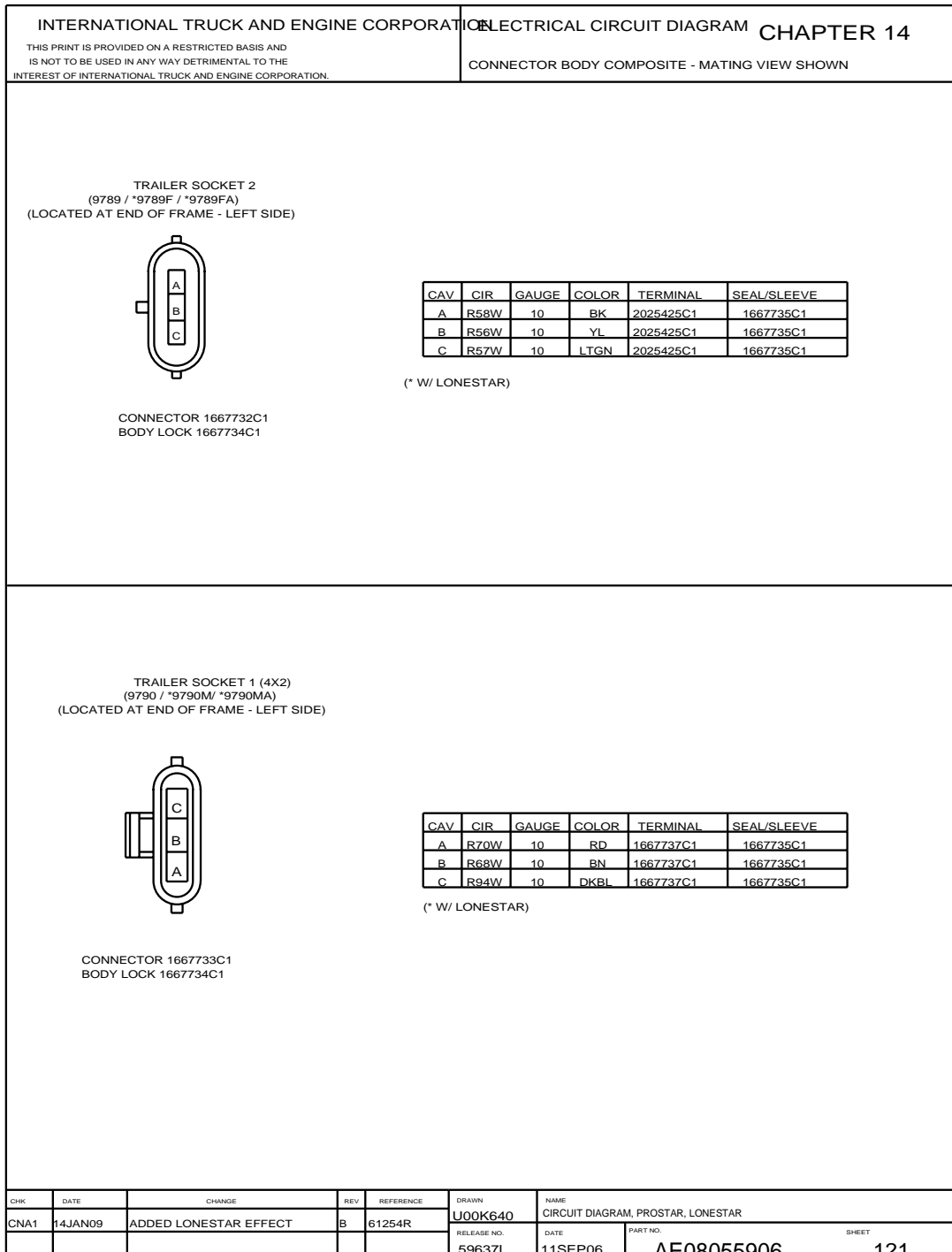


Figure 382 Connector Composites (9780), (9781F), (9782M), (9783F), (9783M), (9784M)

**14.154. CONNECTOR COMPOSITES (9789/9789F/9789FA), (9790/9790M/9790MA),  
P. 121**



**Figure 383 Connector Composites (9789/9789F/9789FA), (9790/9790M/9790MA)**

14.155. CONNECTOR COMPOSITES (9800/9800F/9800M), P. 122

INTERNATIONAL TRUCK AND ENGINE CORPORATION		ELECTRICAL CIRCUIT DIAGRAM		CHAPTER 14																																																																																																																																																																																																																																																													
THIS PRINT IS PROVIDED ON A RESTRICTED BASIS AND IS NOT TO BE USED IN ANY WAY DETRIMENTAL TO THE INTEREST OF INTERNATIONAL TRUCK AND ENGINE CORPORATION.		CONNECTOR BODY COMPOSITE - MATING VIEW SHOWN																																																																																																																																																																																																																																																															
CONNECTION TO REAR / CENTER CHASSIS HARNESS (9800 / 9800F / 9800M) (LOCATED ON LEFT FRAME RAIL BEHIND CAB)																																																																																																																																																																																																																																																																	
CONNECTOR 3558022C1 BODY LOCK 3558056C1			CONNECTOR 3558026C1 BODY LOCK 3558056C1																																																																																																																																																																																																																																																														
<table border="1" style="width:100%; border-collapse: collapse;"> <thead> <tr> <th>CAV</th><th>CJR</th><th>GAUGE</th><th>COLOR</th><th>TERMINAL</th><th>SEAL/SLEEVE</th></tr> </thead> <tbody> <tr><td>1</td><td>R71BA</td><td>14</td><td>OR</td><td>3559037C1</td><td>3575783C1</td></tr> <tr><td>2</td><td>R56A</td><td>14</td><td>OR</td><td>3559037C1</td><td>3575783C1</td></tr> <tr><td>3</td><td>R57A</td><td>14</td><td>OR</td><td>3559037C1</td><td>3575783C1</td></tr> <tr><td>4</td><td>R68A</td><td>14</td><td>BN</td><td>3559037C1</td><td>3575783C1</td></tr> <tr><td>5</td><td>R10-G</td><td>12</td><td>WH</td><td>3559037C1</td><td>3575783C1</td></tr> <tr><td>5##</td><td>R10-G</td><td>16</td><td>WH</td><td>3559037C1</td><td>3509903C1</td></tr> <tr><td>6</td><td>R32A</td><td>18</td><td>TN</td><td>3559036C1</td><td>3509903C1</td></tr> <tr><td>6##</td><td>R32</td><td>18</td><td>TN</td><td>3559036C1</td><td>3509903C1</td></tr> <tr><td>7*</td><td>R9A</td><td>18</td><td>GY</td><td>3559036C1</td><td>3509903C1</td></tr> <tr><td>7*</td><td>R9</td><td>18</td><td>GY</td><td>3559036C1</td><td>3509903C1</td></tr> <tr><td>7##</td><td>R9C</td><td>18</td><td>GY</td><td>3559036C1</td><td>3509903C1</td></tr> <tr><td>8</td><td>R32</td><td>18</td><td>TN</td><td>3559036C1</td><td>3509903C1</td></tr> <tr><td>9</td><td>R49</td><td>18</td><td>GY</td><td>3559036C1</td><td>3509903C1</td></tr> <tr><td>10*</td><td>R49-GC</td><td>18</td><td>WH</td><td>3559036C1</td><td>3509903C1</td></tr> <tr><td>10*</td><td>R49-G</td><td>18</td><td>WH</td><td>3559036C1</td><td>3509903C1</td></tr> <tr><td>11</td><td>R49A</td><td>18</td><td>GY</td><td>3559036C1</td><td>3509903C1</td></tr> <tr><td>12</td><td>R58AC</td><td>16</td><td>BN</td><td>3559037C1</td><td>3509903C1</td></tr> <tr><td>13@</td><td>R94BA</td><td>16</td><td>GY</td><td>3559037C1</td><td>3509903C1</td></tr> <tr><td>13#</td><td>R94MBA</td><td>18</td><td>GY</td><td>3559036C1</td><td>3509903C1</td></tr> <tr><td>14@</td><td>R94BB</td><td>16</td><td>GY</td><td>3559037C1</td><td>3509903C1</td></tr> <tr><td>14#</td><td>R94MBB</td><td>18</td><td>GY</td><td>3559036C1</td><td>3509903C1</td></tr> <tr><td>15@</td><td>R94BC</td><td>16</td><td>GY</td><td>3559037C1</td><td>3509903C1</td></tr> <tr><td>15#</td><td>R94MBC</td><td>18</td><td>GY</td><td>3559036C1</td><td>3509903C1</td></tr> <tr><td>16@</td><td>R94BD</td><td>16</td><td>GY</td><td>3559037C1</td><td>3509903C1</td></tr> <tr><td>16#</td><td>R94MBD</td><td>18</td><td>GY</td><td>3559036C1</td><td>3509903C1</td></tr> <tr><td>17@</td><td>R94BE</td><td>16</td><td>GY</td><td>3559037C1</td><td>3509903C1</td></tr> <tr><td>17#</td><td>R94MBE</td><td>18</td><td>GY</td><td>3559036C1</td><td>3509903C1</td></tr> <tr><td>18@</td><td>R94BF</td><td>16</td><td>GY</td><td>3559037C1</td><td>3509903C1</td></tr> <tr><td>18#</td><td>R94MBF</td><td>18</td><td>GY</td><td>3559036C1</td><td>3509903C1</td></tr> <tr><td>19@</td><td>R94BH</td><td>16</td><td>GY</td><td>3559037C1</td><td>3509903C1</td></tr> <tr><td>19#</td><td>R94MBH</td><td>18</td><td>GY</td><td>3559036C1</td><td>3509903C1</td></tr> <tr><td>20@</td><td>R94BJ</td><td>16</td><td>GY</td><td>3559037C1</td><td>3509903C1</td></tr> <tr><td>20#</td><td>R94MBJ</td><td>18</td><td>GY</td><td>3559036C1</td><td>3509903C1</td></tr> <tr><td>21@</td><td>R94BK</td><td>16</td><td>GY</td><td>3559037C1</td><td>3509903C1</td></tr> <tr><td>21#</td><td>R94MBK</td><td>18</td><td>GY</td><td>3559036C1</td><td>3509903C1</td></tr> <tr><td>22@</td><td>R94BL</td><td>16</td><td>GY</td><td>3559037C1</td><td>3509903C1</td></tr> <tr><td>22#</td><td>R94MBL</td><td>18</td><td>GY</td><td>3559036C1</td><td>3509903C1</td></tr> <tr><td>23@</td><td>R94BM</td><td>16</td><td>GY</td><td>3559037C1</td><td>3509903C1</td></tr> <tr><td>23#</td><td>R94MBM</td><td>18</td><td>GY</td><td>3559036C1</td><td>3509903C1</td></tr> <tr><td>24@</td><td>R94BN</td><td>16</td><td>GY</td><td>3559037C1</td><td>3509903C1</td></tr> <tr><td>24#</td><td>R94MBN</td><td>18</td><td>GY</td><td>3559036C1</td><td>3509903C1</td></tr> </tbody> </table>						CAV	CJR	GAUGE	COLOR	TERMINAL	SEAL/SLEEVE	1	R71BA	14	OR	3559037C1	3575783C1	2	R56A	14	OR	3559037C1	3575783C1	3	R57A	14	OR	3559037C1	3575783C1	4	R68A	14	BN	3559037C1	3575783C1	5	R10-G	12	WH	3559037C1	3575783C1	5##	R10-G	16	WH	3559037C1	3509903C1	6	R32A	18	TN	3559036C1	3509903C1	6##	R32	18	TN	3559036C1	3509903C1	7*	R9A	18	GY	3559036C1	3509903C1	7*	R9	18	GY	3559036C1	3509903C1	7##	R9C	18	GY	3559036C1	3509903C1	8	R32	18	TN	3559036C1	3509903C1	9	R49	18	GY	3559036C1	3509903C1	10*	R49-GC	18	WH	3559036C1	3509903C1	10*	R49-G	18	WH	3559036C1	3509903C1	11	R49A	18	GY	3559036C1	3509903C1	12	R58AC	16	BN	3559037C1	3509903C1	13@	R94BA	16	GY	3559037C1	3509903C1	13#	R94MBA	18	GY	3559036C1	3509903C1	14@	R94BB	16	GY	3559037C1	3509903C1	14#	R94MBB	18	GY	3559036C1	3509903C1	15@	R94BC	16	GY	3559037C1	3509903C1	15#	R94MBC	18	GY	3559036C1	3509903C1	16@	R94BD	16	GY	3559037C1	3509903C1	16#	R94MBD	18	GY	3559036C1	3509903C1	17@	R94BE	16	GY	3559037C1	3509903C1	17#	R94MBE	18	GY	3559036C1	3509903C1	18@	R94BF	16	GY	3559037C1	3509903C1	18#	R94MBF	18	GY	3559036C1	3509903C1	19@	R94BH	16	GY	3559037C1	3509903C1	19#	R94MBH	18	GY	3559036C1	3509903C1	20@	R94BJ	16	GY	3559037C1	3509903C1	20#	R94MBJ	18	GY	3559036C1	3509903C1	21@	R94BK	16	GY	3559037C1	3509903C1	21#	R94MBK	18	GY	3559036C1	3509903C1	22@	R94BL	16	GY	3559037C1	3509903C1	22#	R94MBL	18	GY	3559036C1	3509903C1	23@	R94BM	16	GY	3559037C1	3509903C1	23#	R94MBM	18	GY	3559036C1	3509903C1	24@	R94BN	16	GY	3559037C1	3509903C1	24#	R94MBN	18	GY	3559036C1	3509903C1
CAV	CJR	GAUGE	COLOR	TERMINAL	SEAL/SLEEVE																																																																																																																																																																																																																																																												
1	R71BA	14	OR	3559037C1	3575783C1																																																																																																																																																																																																																																																												
2	R56A	14	OR	3559037C1	3575783C1																																																																																																																																																																																																																																																												
3	R57A	14	OR	3559037C1	3575783C1																																																																																																																																																																																																																																																												
4	R68A	14	BN	3559037C1	3575783C1																																																																																																																																																																																																																																																												
5	R10-G	12	WH	3559037C1	3575783C1																																																																																																																																																																																																																																																												
5##	R10-G	16	WH	3559037C1	3509903C1																																																																																																																																																																																																																																																												
6	R32A	18	TN	3559036C1	3509903C1																																																																																																																																																																																																																																																												
6##	R32	18	TN	3559036C1	3509903C1																																																																																																																																																																																																																																																												
7*	R9A	18	GY	3559036C1	3509903C1																																																																																																																																																																																																																																																												
7*	R9	18	GY	3559036C1	3509903C1																																																																																																																																																																																																																																																												
7##	R9C	18	GY	3559036C1	3509903C1																																																																																																																																																																																																																																																												
8	R32	18	TN	3559036C1	3509903C1																																																																																																																																																																																																																																																												
9	R49	18	GY	3559036C1	3509903C1																																																																																																																																																																																																																																																												
10*	R49-GC	18	WH	3559036C1	3509903C1																																																																																																																																																																																																																																																												
10*	R49-G	18	WH	3559036C1	3509903C1																																																																																																																																																																																																																																																												
11	R49A	18	GY	3559036C1	3509903C1																																																																																																																																																																																																																																																												
12	R58AC	16	BN	3559037C1	3509903C1																																																																																																																																																																																																																																																												
13@	R94BA	16	GY	3559037C1	3509903C1																																																																																																																																																																																																																																																												
13#	R94MBA	18	GY	3559036C1	3509903C1																																																																																																																																																																																																																																																												
14@	R94BB	16	GY	3559037C1	3509903C1																																																																																																																																																																																																																																																												
14#	R94MBB	18	GY	3559036C1	3509903C1																																																																																																																																																																																																																																																												
15@	R94BC	16	GY	3559037C1	3509903C1																																																																																																																																																																																																																																																												
15#	R94MBC	18	GY	3559036C1	3509903C1																																																																																																																																																																																																																																																												
16@	R94BD	16	GY	3559037C1	3509903C1																																																																																																																																																																																																																																																												
16#	R94MBD	18	GY	3559036C1	3509903C1																																																																																																																																																																																																																																																												
17@	R94BE	16	GY	3559037C1	3509903C1																																																																																																																																																																																																																																																												
17#	R94MBE	18	GY	3559036C1	3509903C1																																																																																																																																																																																																																																																												
18@	R94BF	16	GY	3559037C1	3509903C1																																																																																																																																																																																																																																																												
18#	R94MBF	18	GY	3559036C1	3509903C1																																																																																																																																																																																																																																																												
19@	R94BH	16	GY	3559037C1	3509903C1																																																																																																																																																																																																																																																												
19#	R94MBH	18	GY	3559036C1	3509903C1																																																																																																																																																																																																																																																												
20@	R94BJ	16	GY	3559037C1	3509903C1																																																																																																																																																																																																																																																												
20#	R94MBJ	18	GY	3559036C1	3509903C1																																																																																																																																																																																																																																																												
21@	R94BK	16	GY	3559037C1	3509903C1																																																																																																																																																																																																																																																												
21#	R94MBK	18	GY	3559036C1	3509903C1																																																																																																																																																																																																																																																												
22@	R94BL	16	GY	3559037C1	3509903C1																																																																																																																																																																																																																																																												
22#	R94MBL	18	GY	3559036C1	3509903C1																																																																																																																																																																																																																																																												
23@	R94BM	16	GY	3559037C1	3509903C1																																																																																																																																																																																																																																																												
23#	R94MBM	18	GY	3559036C1	3509903C1																																																																																																																																																																																																																																																												
24@	R94BN	16	GY	3559037C1	3509903C1																																																																																																																																																																																																																																																												
24#	R94MBN	18	GY	3559036C1	3509903C1																																																																																																																																																																																																																																																												
<table border="1" style="width:100%; border-collapse: collapse;"> <thead> <tr> <th>CAV</th><th>CJR</th><th>GAUGE</th><th>COLOR</th><th>TERMINAL</th><th>SEAL/SLEEVE</th></tr> </thead> <tbody> <tr><td>1</td><td>N71BA</td><td>14</td><td>OR</td><td>3559035C1</td><td>3575783C1</td></tr> <tr><td>2</td><td>N56A</td><td>14</td><td>OR</td><td>3559035C1</td><td>3575783C1</td></tr> <tr><td>3</td><td>N57A</td><td>14</td><td>OR</td><td>3559035C1</td><td>3575783C1</td></tr> <tr><td>4</td><td>N68A</td><td>14</td><td>BN</td><td>3559035C1</td><td>3575783C1</td></tr> <tr><td>5</td><td>N10-G</td><td>12</td><td>WH</td><td>3559035C1</td><td>3575783C1</td></tr> <tr><td>6</td><td>N32A</td><td>18</td><td>TN</td><td>3509874C1</td><td>3509903C1</td></tr> <tr><td>7</td><td>N9BF</td><td>18</td><td>GY</td><td>3509874C1</td><td>3509903C1</td></tr> <tr><td>8</td><td>N32</td><td>18</td><td>TN</td><td>3509874C1</td><td>3509903C1</td></tr> <tr><td>9</td><td>N49</td><td>18</td><td>GY</td><td>3509874C1</td><td>3509903C1</td></tr> <tr><td>10</td><td>N49-G</td><td>18</td><td>WH</td><td>3509874C1</td><td>3509903C1</td></tr> <tr><td>11</td><td>N49A</td><td>18</td><td>GY</td><td>3509874C1</td><td>3509903C1</td></tr> <tr><td>12</td><td>PLUG</td><td>-</td><td>-</td><td>3532129C1</td><td>-</td></tr> <tr><td>13</td><td>N94BA</td><td>16</td><td>GY</td><td>3559035C1</td><td>3509903C1</td></tr> <tr><td>14</td><td>N94BB</td><td>16</td><td>GY</td><td>3559035C1</td><td>3509903C1</td></tr> <tr><td>15</td><td>N94BC</td><td>16</td><td>GY</td><td>3559035C1</td><td>3509903C1</td></tr> <tr><td>16</td><td>N94BD</td><td>16</td><td>GY</td><td>3559035C1</td><td>3509903C1</td></tr> <tr><td>17</td><td>N94BE</td><td>16</td><td>GY</td><td>3559035C1</td><td>3509903C1</td></tr> <tr><td>18</td><td>N94BF</td><td>16</td><td>GY</td><td>3559035C1</td><td>3509903C1</td></tr> <tr><td>19</td><td>N94BH</td><td>16</td><td>GY</td><td>3559035C1</td><td>3509903C1</td></tr> <tr><td>20</td><td>N94BJ</td><td>16</td><td>GY</td><td>3559035C1</td><td>3509903C1</td></tr> <tr><td>21</td><td>N94BK</td><td>16</td><td>GY</td><td>3559035C1</td><td>3509903C1</td></tr> <tr><td>22</td><td>N94BL</td><td>16</td><td>GY</td><td>3559035C1</td><td>3509903C1</td></tr> <tr><td>23</td><td>N94BM</td><td>16</td><td>GY</td><td>3559035C1</td><td>3509903C1</td></tr> <tr><td>24</td><td>N94BN</td><td>16</td><td>GY</td><td>3559035C1</td><td>3509903C1</td></tr> </tbody> </table>						CAV	CJR	GAUGE	COLOR	TERMINAL	SEAL/SLEEVE	1	N71BA	14	OR	3559035C1	3575783C1	2	N56A	14	OR	3559035C1	3575783C1	3	N57A	14	OR	3559035C1	3575783C1	4	N68A	14	BN	3559035C1	3575783C1	5	N10-G	12	WH	3559035C1	3575783C1	6	N32A	18	TN	3509874C1	3509903C1	7	N9BF	18	GY	3509874C1	3509903C1	8	N32	18	TN	3509874C1	3509903C1	9	N49	18	GY	3509874C1	3509903C1	10	N49-G	18	WH	3509874C1	3509903C1	11	N49A	18	GY	3509874C1	3509903C1	12	PLUG	-	-	3532129C1	-	13	N94BA	16	GY	3559035C1	3509903C1	14	N94BB	16	GY	3559035C1	3509903C1	15	N94BC	16	GY	3559035C1	3509903C1	16	N94BD	16	GY	3559035C1	3509903C1	17	N94BE	16	GY	3559035C1	3509903C1	18	N94BF	16	GY	3559035C1	3509903C1	19	N94BH	16	GY	3559035C1	3509903C1	20	N94BJ	16	GY	3559035C1	3509903C1	21	N94BK	16	GY	3559035C1	3509903C1	22	N94BL	16	GY	3559035C1	3509903C1	23	N94BM	16	GY	3559035C1	3509903C1	24	N94BN	16	GY	3559035C1	3509903C1																																																																																																						
CAV	CJR	GAUGE	COLOR	TERMINAL	SEAL/SLEEVE																																																																																																																																																																																																																																																												
1	N71BA	14	OR	3559035C1	3575783C1																																																																																																																																																																																																																																																												
2	N56A	14	OR	3559035C1	3575783C1																																																																																																																																																																																																																																																												
3	N57A	14	OR	3559035C1	3575783C1																																																																																																																																																																																																																																																												
4	N68A	14	BN	3559035C1	3575783C1																																																																																																																																																																																																																																																												
5	N10-G	12	WH	3559035C1	3575783C1																																																																																																																																																																																																																																																												
6	N32A	18	TN	3509874C1	3509903C1																																																																																																																																																																																																																																																												
7	N9BF	18	GY	3509874C1	3509903C1																																																																																																																																																																																																																																																												
8	N32	18	TN	3509874C1	3509903C1																																																																																																																																																																																																																																																												
9	N49	18	GY	3509874C1	3509903C1																																																																																																																																																																																																																																																												
10	N49-G	18	WH	3509874C1	3509903C1																																																																																																																																																																																																																																																												
11	N49A	18	GY	3509874C1	3509903C1																																																																																																																																																																																																																																																												
12	PLUG	-	-	3532129C1	-																																																																																																																																																																																																																																																												
13	N94BA	16	GY	3559035C1	3509903C1																																																																																																																																																																																																																																																												
14	N94BB	16	GY	3559035C1	3509903C1																																																																																																																																																																																																																																																												
15	N94BC	16	GY	3559035C1	3509903C1																																																																																																																																																																																																																																																												
16	N94BD	16	GY	3559035C1	3509903C1																																																																																																																																																																																																																																																												
17	N94BE	16	GY	3559035C1	3509903C1																																																																																																																																																																																																																																																												
18	N94BF	16	GY	3559035C1	3509903C1																																																																																																																																																																																																																																																												
19	N94BH	16	GY	3559035C1	3509903C1																																																																																																																																																																																																																																																												
20	N94BJ	16	GY	3559035C1	3509903C1																																																																																																																																																																																																																																																												
21	N94BK	16	GY	3559035C1	3509903C1																																																																																																																																																																																																																																																												
22	N94BL	16	GY	3559035C1	3509903C1																																																																																																																																																																																																																																																												
23	N94BM	16	GY	3559035C1	3509903C1																																																																																																																																																																																																																																																												
24	N94BN	16	GY	3559035C1	3509903C1																																																																																																																																																																																																																																																												
* MUTUALLY EXCLUSIVE @ W/ BENDIX ABS # W/ WABCO ABS ## W/ LONESTAR																																																																																																																																																																																																																																																																	
CHK	DATE	CHANGE	REV	REFERENCE	DRAWN	NAME																																																																																																																																																																																																																																																											
CNA1	16JUN09	LONESTAR WAS TOPGUN.	C	61610P	U00K640	CIRCUIT DIAGRAM, PROSTAR, LONESTAR																																																																																																																																																																																																																																																											
					RELEASE NO.	DATE																																																																																																																																																																																																																																																											
					59637L	11SEP06																																																																																																																																																																																																																																																											
						PART NO.																																																																																																																																																																																																																																																											
						AE08055906																																																																																																																																																																																																																																																											
						SHEET																																																																																																																																																																																																																																																											
						122																																																																																																																																																																																																																																																											

Figure 384 Connector Composites (9800/9800F/9800M)

14.156. CONNECTOR COMPOSITES (9801/9801F/9801M), P. 123

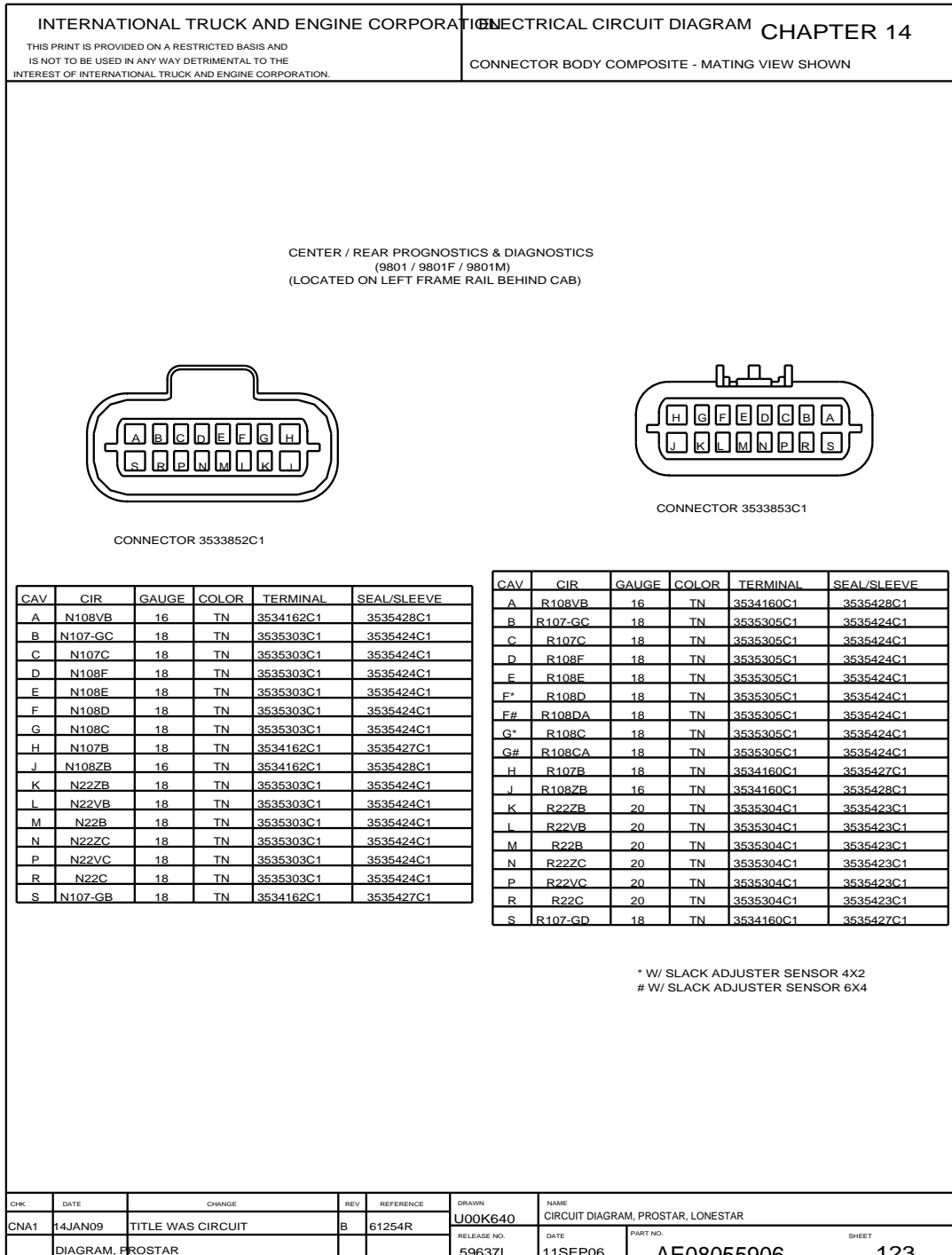


Figure 385 Connector Composites (9801/9801F/9801M)

14.157. CONNECTOR COMPOSITES (9811), (9812), (9813), P. 124

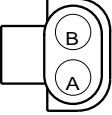
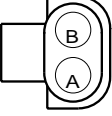
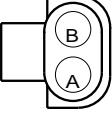
<p>INTERNATIONAL TRUCK AND ENGINE CORPORATION</p> <p><small>THIS PRINT IS PROVIDED ON A RESTRICTED BASIS AND IS NOT TO BE USED IN ANY WAY DETRIMENTAL TO THE INTEREST OF INTERNATIONAL TRUCK AND ENGINE CORPORATION.</small></p>	<p>ELECTRICAL CIRCUIT DIAGRAM CHAPTER 14</p> <p>CONNECTOR BODY COMPOSITE - MATING VIEW SHOWN</p>																												
<p>FRONT AXLE TEMP SENDER (9811) (LOCATED ON LEFT FRAME RAIL BY FORWARD REAR AXLE)</p>																													
	<table border="1" style="border-collapse: collapse; font-size: 8px;"> <thead> <tr> <th>CAV</th> <th>CIR</th> <th>GAUGE</th> <th>COLOR</th> <th>TERMINAL</th> <th>SEAL/SLEEVE</th> </tr> </thead> <tbody> <tr> <td>A</td> <td>R32</td> <td>18</td> <td>TN</td> <td>0587576C1</td> <td>1652325C1</td> </tr> <tr> <td>B</td> <td>R9C</td> <td>18</td> <td>GY</td> <td>0587576C1</td> <td>1652325C1</td> </tr> </tbody> </table>	CAV	CIR	GAUGE	COLOR	TERMINAL	SEAL/SLEEVE	A	R32	18	TN	0587576C1	1652325C1	B	R9C	18	GY	0587576C1	1652325C1										
CAV	CIR	GAUGE	COLOR	TERMINAL	SEAL/SLEEVE																								
A	R32	18	TN	0587576C1	1652325C1																								
B	R9C	18	GY	0587576C1	1652325C1																								
<p>CONNECTOR 0587568C91</p>																													
<p>REAR AXLE TEMP (6X4) SENDER (9812) (LOCATED ON LEFT FRAME RAIL BY REAR REAR AXLE)</p>																													
	<table border="1" style="border-collapse: collapse; font-size: 8px;"> <thead> <tr> <th>CAV</th> <th>CIR</th> <th>GAUGE</th> <th>COLOR</th> <th>TERMINAL</th> <th>SEAL/SLEEVE</th> </tr> </thead> <tbody> <tr> <td>A</td> <td>R32A</td> <td>18</td> <td>TN</td> <td>0587576C1</td> <td>1652325C1</td> </tr> <tr> <td>B</td> <td>R9B</td> <td>18</td> <td>GY</td> <td>0587576C1</td> <td>1652325C1</td> </tr> </tbody> </table>	CAV	CIR	GAUGE	COLOR	TERMINAL	SEAL/SLEEVE	A	R32A	18	TN	0587576C1	1652325C1	B	R9B	18	GY	0587576C1	1652325C1										
CAV	CIR	GAUGE	COLOR	TERMINAL	SEAL/SLEEVE																								
A	R32A	18	TN	0587576C1	1652325C1																								
B	R9B	18	GY	0587576C1	1652325C1																								
<p>CONNECTOR 0587568C91</p>																													
<p>REAR AXLE TEMP SENDER (4X2) (9813) (LOCATED ON LEFT FRAME RAIL BY REAR AXLE)</p>																													
	<table border="1" style="border-collapse: collapse; font-size: 8px;"> <thead> <tr> <th>CAV</th> <th>CIR</th> <th>GAUGE</th> <th>COLOR</th> <th>TERMINAL</th> <th>SEAL/SLEEVE</th> </tr> </thead> <tbody> <tr> <td>A</td> <td>R32A</td> <td>18</td> <td>TN</td> <td>0587576C1</td> <td>1652325C1</td> </tr> <tr> <td>B</td> <td>R9</td> <td>18</td> <td>GY</td> <td>0587576C1</td> <td>1652325C1</td> </tr> </tbody> </table>	CAV	CIR	GAUGE	COLOR	TERMINAL	SEAL/SLEEVE	A	R32A	18	TN	0587576C1	1652325C1	B	R9	18	GY	0587576C1	1652325C1										
CAV	CIR	GAUGE	COLOR	TERMINAL	SEAL/SLEEVE																								
A	R32A	18	TN	0587576C1	1652325C1																								
B	R9	18	GY	0587576C1	1652325C1																								
<p>CONNECTOR 0587568C91</p>																													
<table border="1" style="width:100%; border-collapse: collapse;"> <tr> <th>CHK</th> <th>DATE</th> <th>CHANGE</th> <th>REV</th> <th>REFERENCE</th> <th>DRAWN</th> <th>NAME</th> </tr> <tr> <td>CNA1</td> <td>14JAN09</td> <td>TITLE WAS CIRCUIT</td> <td>B</td> <td>61254R</td> <td>U00K640</td> <td>CIRCUIT DIAGRAM, PROSTAR, LONESTAR</td> </tr> <tr> <td></td> <td></td> <td>DIAGRAM, PROSTAR</td> <td></td> <td></td> <td>59637L</td> <td>11SEP06</td> </tr> <tr> <td colspan="5"></td> <td>AE08055906</td> <td style="text-align: right;">124</td> </tr> </table>		CHK	DATE	CHANGE	REV	REFERENCE	DRAWN	NAME	CNA1	14JAN09	TITLE WAS CIRCUIT	B	61254R	U00K640	CIRCUIT DIAGRAM, PROSTAR, LONESTAR			DIAGRAM, PROSTAR			59637L	11SEP06						AE08055906	124
CHK	DATE	CHANGE	REV	REFERENCE	DRAWN	NAME																							
CNA1	14JAN09	TITLE WAS CIRCUIT	B	61254R	U00K640	CIRCUIT DIAGRAM, PROSTAR, LONESTAR																							
		DIAGRAM, PROSTAR			59637L	11SEP06																							
					AE08055906	124																							

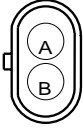
Figure 386 Connector Composites (9811), (9812), (9813)

14.158. CONNECTOR COMPOSITES (9814), (9815), (9816), P. 125

<p>INTERNATIONAL TRUCK AND ENGINE CORPORATION</p> <p><small>THIS PRINT IS PROVIDED ON A RESTRICTED BASIS AND IS NOT TO BE USED IN ANY WAY DETRIMENTAL TO THE INTEREST OF INTERNATIONAL TRUCK AND ENGINE CORPORATION.</small></p>	<p>ELECTRICAL CIRCUIT DIAGRAM CHAPTER 14</p> <p>CONNECTOR BODY COMPOSITE - MATING VIEW SHOWN</p>
--	--

6X4 FORWARD REAR AXLE DIFF  
LOCKED INDICATOR SWITCH  
(9814)  
(LOCATED ON FRONT OF FORWARD REAR AXLE)

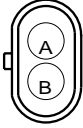


CAV	CIR	GAUGE	COLOR	TERMINAL	SEAL/SLEEVE
A*	R49A	18	GY	0587578C1	1652325C1
A#	R49	18	GY	0587578C1	1652325C1
B*	R49-GB	18	WH	0587578C1	1652325C1
B#	R49-G	18	WH	0587578C1	1652325C1

CONNECTOR 0587567C91

\* W/ TWO DIFF LOCK WARN LIGHT (6X4)  
# W/ ONE DIFF LOCK WARN LT(6X4) W/ TAG

6X4 REAR REAR AXLE DIFF  
LOCKED INDICATOR SWITCH  
(9815)  
(LOCATED ON FRONT OF REAR REAR AXLE)

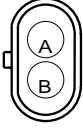


CAV	CIR	GAUGE	COLOR	TERMINAL	SEAL/SLEEVE
A	R49	18	GY	0587578C1	1652325C1
B*	R49-G	18	WH	0587578C1	1652325C1
B#	R49-GA	18	WH	0587578C1	1652325C1

CONNECTOR 0587567C91

\* W/ ONE DIFF LOCK WARN LIGHT  
# W/ TWO DIFF LOCK WARN LIGHT

4X2 REAR AXLE DIFF  
LOCKED INDICATOR SWITCH  
(9816)  
(LOCATED ON FRONT OF REAR AXLE)



CAV	CIR	GAUGE	COLOR	TERMINAL	SEAL/SLEEVE
A	R49	18	GY	0587578C1	1652325C1
B	R49-G	18	WH	0587578C1	1652325C1

CONNECTOR 0587567C91

CHK	DATE	CHANGE	REV	REFERENCE	DRAWN	NAME
CNA1	14JAN09	TITLE WAS CIRCUIT	C	61254R	U00K640	CIRCUIT DIAGRAM, PROSTAR, LONESTAR
		DIAGRAM, PROSTAR			59637L	
					11SEP06	
					AE08055906	125

Figure 387 Connector Composites (9814), (9815), (9816)

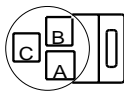
14.159. CONNECTOR COMPOSITES (9830/9832), (9865/9865F/9865M), P. 126

<p>INTERNATIONAL TRUCK AND ENGINE CORPORATION</p> <p><small>THIS PRINT IS PROVIDED ON A RESTRICTED BASIS AND IS NOT TO BE USED IN ANY WAY DETRIMENTAL TO THE INTEREST OF INTERNATIONAL TRUCK AND ENGINE CORPORATION.</small></p>	<p>ELECTRICAL CIRCUIT DIAGRAM CHAPTER 14</p> <p>CONNECTOR BODY COMPOSITE - MATING VIEW SHOWN</p>
--	--

REAR LOAD INDICATOR  
(9830 - 4X2)  
(9832 - 6X4)

(LOCATED ON REAR SUSPENSION AIR BAG:  
LEFT SIDE - 6X4  
RIGHT SIDE 4X2)

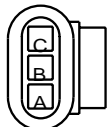


CONNECTOR 1678137C1

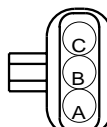
CAV	CIR	GAUGE	COLOR	TERMINAL
A	R109B	18	GY	1651943C1
B	R106B	18	GY	1651943C1
C	R61B	18	GY	1651943C1

LOAD INDICATOR CENTER CHASSIS / REAR CHASSIS  
(9865 / 9865M / 9865F)  
(LOCATED ON LEFT FRAME RAIL BEHIND CAB)



CONNECTOR 1667741C1  
BODY LOCK 166771C1



CONNECTOR 1667740C1  
BODY LOCK 166771C1

CAV	CIR	GAUGE	COLOR	TERMINAL	SEAL/SLEEVE
A	N109B	18	GY	1667742C1	1661872C1
A*	N109B	18	GY	1661875C1	1661872C1
B	N106B	18	GY	1667742C1	1661872C1
B*	N106B	18	GY	1661875C1	1661872C1
C	N61B	18	GY	1667742C1	1661872C1
C*	N61B	18	GY	1661875C1	1661872C1

CAV	CIR	GAUGE	COLOR	TERMINAL	SEAL/SLEEVE
A	R109B	18	GY	1661875C1	1661872C1
A*	R109B	18	GY	1667742C1	1661872C1
B	R106B	18	GY	1661875C1	1661872C1
B*	R106B	18	GY	1667742C1	1661872C1
C	R61B	18	GY	1661875C1	1661872C1
C*	R61B	18	GY	1667742C1	1661872C1

\* W/ LONESTAR

CHK	DATE	CHANGE	REV	REFERENCE	DRAWN	NAME
CNA1	20JAN09	ADDED LONESTAR EFFECT	B	61254R	300371	CIRCUIT DIAGRAM, PROSTAR, LONESTAR
					RELEASE NO. 50297W	DATE 18OCT07
						PART NO. AE08055906
						SHEET 126

Figure 388 Connector Composites (9830/9832), (9865/9865F/9865M)

14.160. CONNECTOR COMPOSITES (9900), (9901), (9902), P. 127

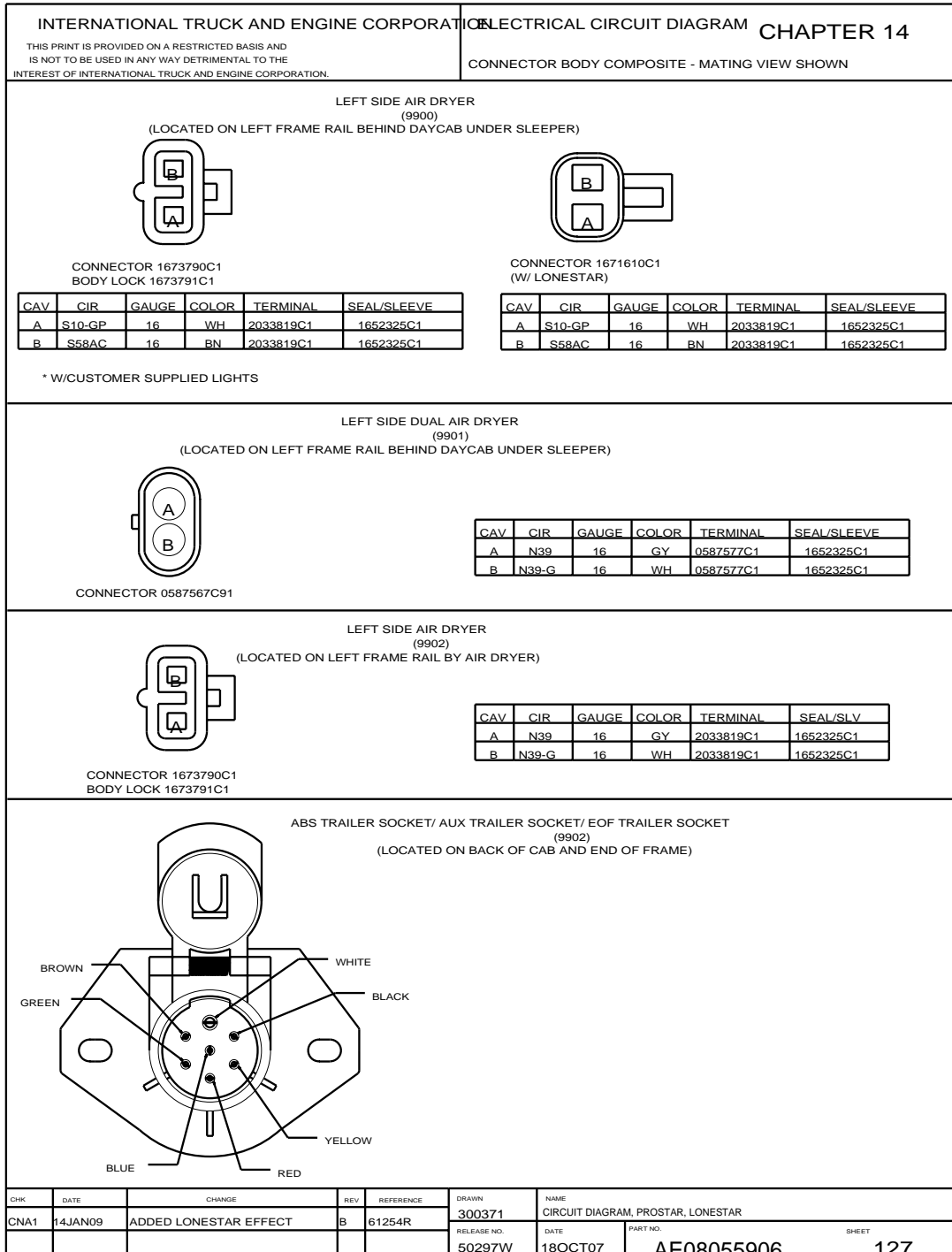


Figure 389 Connector Composites (9900), (9901), (9902)

### 15. SUPPLEMENT FOR CUMMINS EPA98 ISX ENGINE (PROSTAR ONLY)

### 15.1. ELECTRONIC ENGINE CONTROLS — CUMMINS EPA98 ISX (PROSTAR ONLY), P. 2

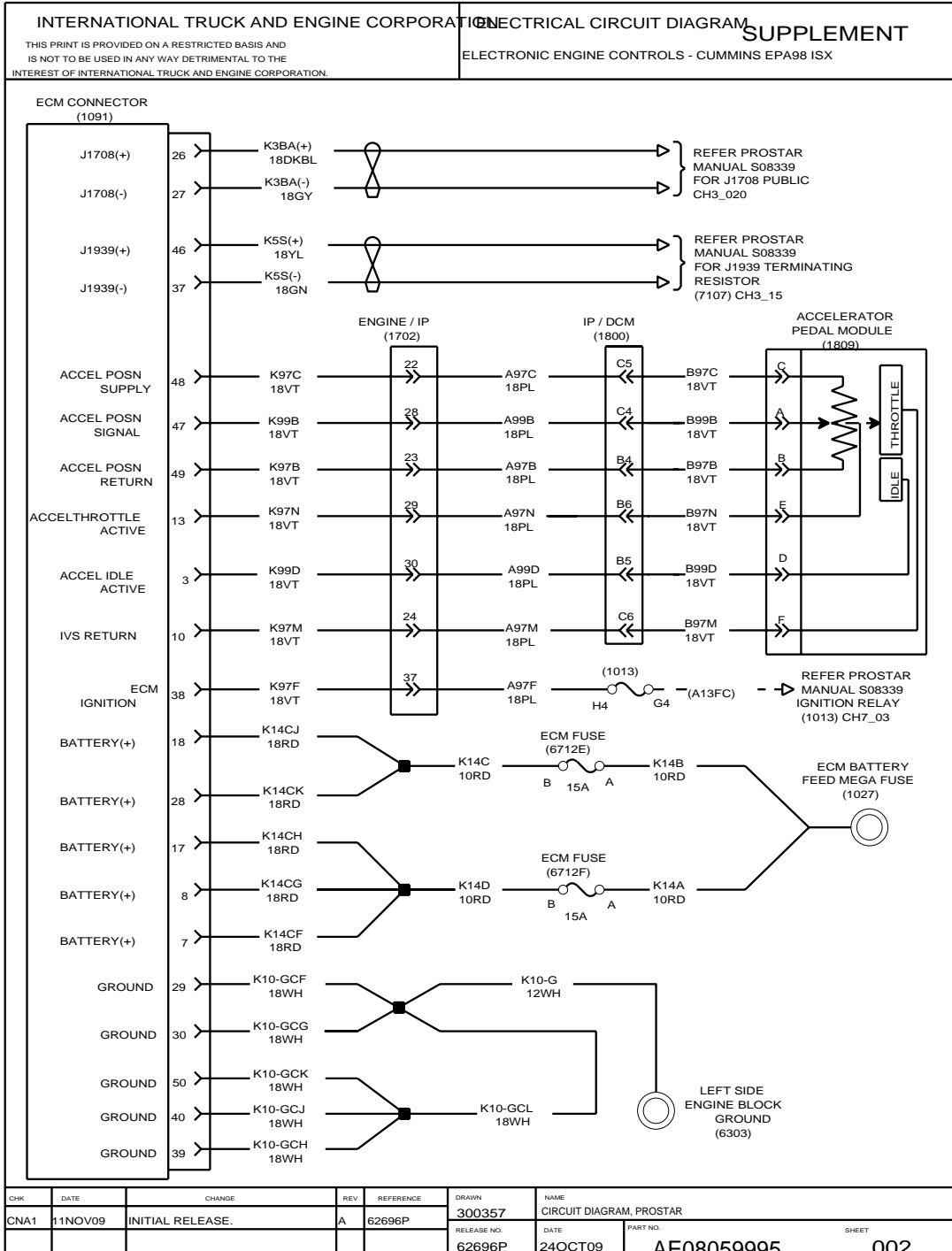


Figure 390 Electronic Engine Controls — Cummins EPA98 ISX

15.2. ELECTRONIC ENGINE CONTROLS — CUMMINS EPA98 ISX (PROSTAR ONLY), P. 3

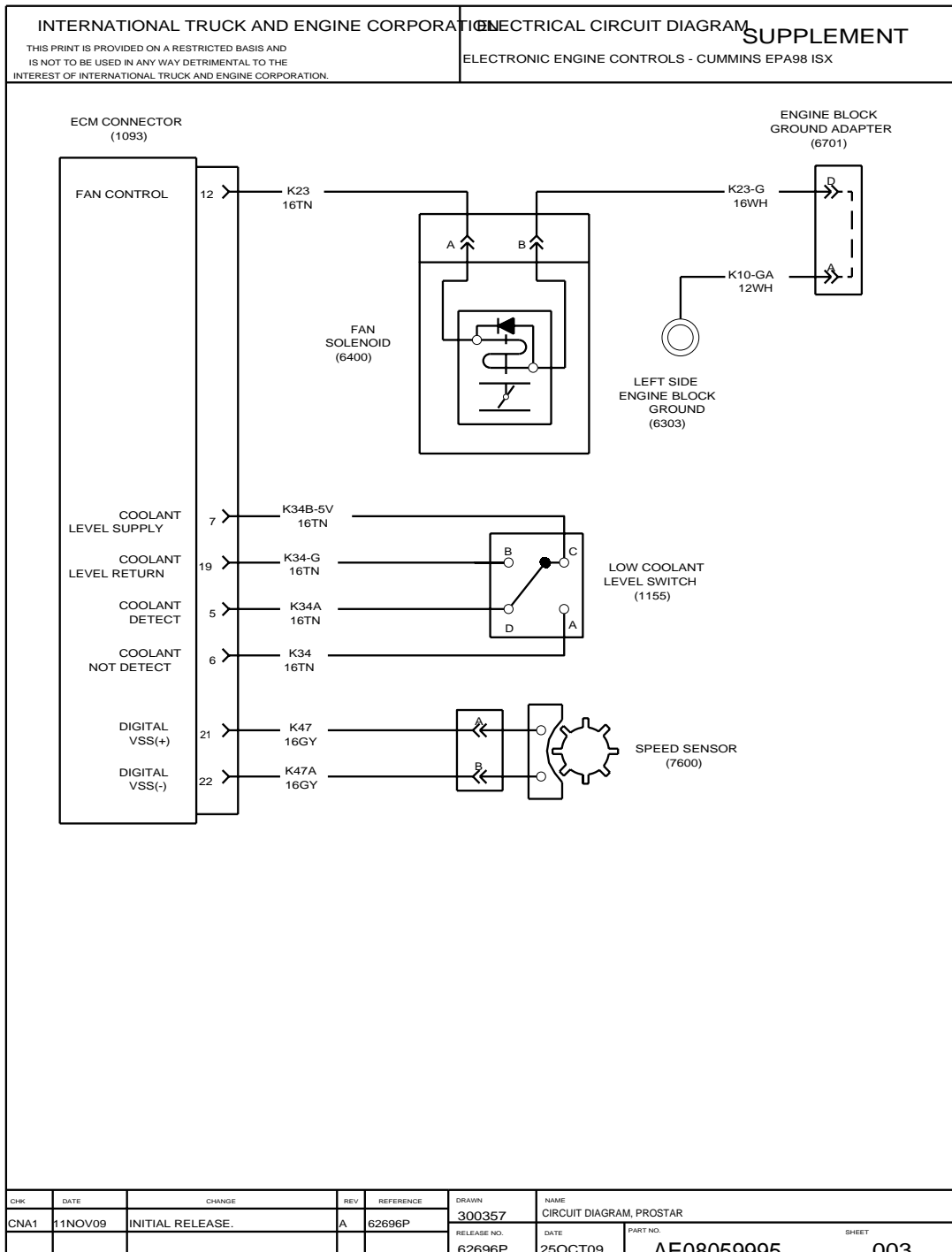


Figure 391 Electronic Engine Controls — Cummins EPA98 ISX

15.3. CONNECTOR COMPOSITES (1091), (PROSTAR ONLY), P. 4

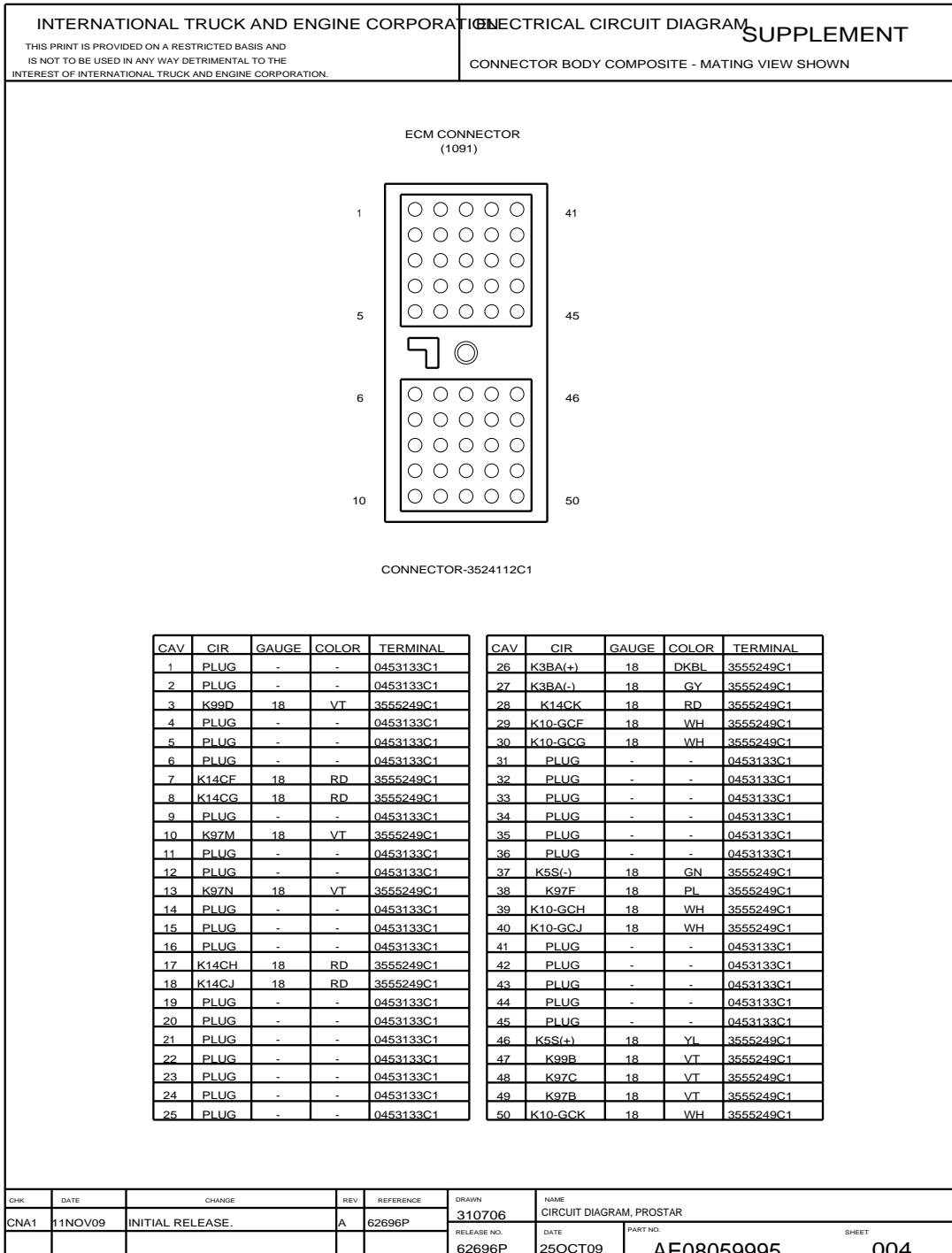


Figure 392 Connector Composites (1091)

15.4. CONNECTOR COMPOSITES (1093), (1155), (PROSTAR ONLY), P. 5

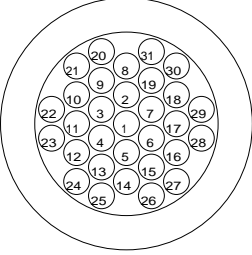
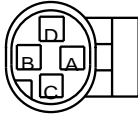
INTERNATIONAL TRUCK AND ENGINE CORPORATION				ELECTRICAL CIRCUIT DIAGRAM SUPPLEMENT																																																																																																																																																																																																	
THIS PRINT IS PROVIDED ON A RESTRICTED BASIS AND IS NOT TO BE USED IN ANY WAY DETRIMENTAL TO THE INTEREST OF INTERNATIONAL TRUCK AND ENGINE CORPORATION.				CONNECTOR BODY COMPOSITE - MATING VIEW SHOWN																																																																																																																																																																																																	
<p>ECM CONNECTOR (1093)</p>  <p>CONNECTOR 3688256C1</p>				<p>LOW COOLANT SENSOR (1155)</p>  <p>CONNECTOR 1673746C1</p>																																																																																																																																																																																																	
<table border="1" style="width:100%; border-collapse: collapse; font-size: x-small;"> <thead> <tr> <th>CAV</th> <th>CIR</th> <th>GAUGE</th> <th>COLOR</th> <th>TERMINAL</th> </tr> </thead> <tbody> <tr><td>1</td><td>PLUG</td><td>-</td><td>-</td><td>0453133C1</td></tr> <tr><td>2</td><td>PLUG</td><td>-</td><td>-</td><td>0453133C1</td></tr> <tr><td>3</td><td>PLUG</td><td>-</td><td>-</td><td>0453133C1</td></tr> <tr><td>4</td><td>PLUG</td><td>-</td><td>-</td><td>0453133C1</td></tr> <tr><td>5</td><td>K34A</td><td>16</td><td>TN</td><td>1680205C1</td></tr> <tr><td>6</td><td>K34</td><td>16</td><td>TN</td><td>1680205C1</td></tr> <tr><td>7</td><td>K34B-5V</td><td>16</td><td>TN</td><td>1680205C1</td></tr> <tr><td>8</td><td>PLUG</td><td>-</td><td>-</td><td>0453133C1</td></tr> <tr><td>9</td><td>PLUG</td><td>-</td><td>-</td><td>0453133C1</td></tr> <tr><td>10</td><td>PLUG</td><td>-</td><td>-</td><td>0453133C1</td></tr> <tr><td>11</td><td>PLUG</td><td>-</td><td>-</td><td>0453133C1</td></tr> <tr><td>12</td><td>K23</td><td>16</td><td>TN</td><td>1680205C1</td></tr> <tr><td>13</td><td>PLUG</td><td>-</td><td>-</td><td>0453133C1</td></tr> <tr><td>14</td><td>PLUG</td><td>-</td><td>-</td><td>0453133C1</td></tr> <tr><td>15</td><td>PLUG</td><td>-</td><td>-</td><td>0453133C1</td></tr> <tr><td>16</td><td>PLUG</td><td>-</td><td>-</td><td>0453133C1</td></tr> <tr><td>17</td><td>PLUG</td><td>-</td><td>-</td><td>0453133C1</td></tr> <tr><td>18</td><td>PLUG</td><td>-</td><td>-</td><td>0453133C1</td></tr> <tr><td>19</td><td>K34-G</td><td>16</td><td>TN</td><td>1680205C1</td></tr> <tr><td>20</td><td>PLUG</td><td>-</td><td>-</td><td>0453133C1</td></tr> <tr><td>21</td><td>K47</td><td>16</td><td>GY</td><td>1680205C1</td></tr> <tr><td>22</td><td>K47A</td><td>16</td><td>GY</td><td>1680205C1</td></tr> <tr><td>23</td><td>PLUG</td><td>-</td><td>-</td><td>0453133C1</td></tr> <tr><td>24</td><td>PLUG</td><td>-</td><td>-</td><td>0453133C1</td></tr> <tr><td>25</td><td>PLUG</td><td>-</td><td>-</td><td>0453133C1</td></tr> <tr><td>26</td><td>PLUG</td><td>-</td><td>-</td><td>0453133C1</td></tr> <tr><td>27</td><td>PLUG</td><td>-</td><td>-</td><td>0453133C1</td></tr> <tr><td>28</td><td>PLUG</td><td>-</td><td>-</td><td>0453133C1</td></tr> <tr><td>29</td><td>PLUG</td><td>-</td><td>-</td><td>0453133C1</td></tr> <tr><td>30</td><td>PLUG</td><td>-</td><td>-</td><td>0453133C1</td></tr> <tr><td>31</td><td>PLUG</td><td>-</td><td>-</td><td>0453133C1</td></tr> </tbody> </table>				CAV	CIR	GAUGE	COLOR	TERMINAL	1	PLUG	-	-	0453133C1	2	PLUG	-	-	0453133C1	3	PLUG	-	-	0453133C1	4	PLUG	-	-	0453133C1	5	K34A	16	TN	1680205C1	6	K34	16	TN	1680205C1	7	K34B-5V	16	TN	1680205C1	8	PLUG	-	-	0453133C1	9	PLUG	-	-	0453133C1	10	PLUG	-	-	0453133C1	11	PLUG	-	-	0453133C1	12	K23	16	TN	1680205C1	13	PLUG	-	-	0453133C1	14	PLUG	-	-	0453133C1	15	PLUG	-	-	0453133C1	16	PLUG	-	-	0453133C1	17	PLUG	-	-	0453133C1	18	PLUG	-	-	0453133C1	19	K34-G	16	TN	1680205C1	20	PLUG	-	-	0453133C1	21	K47	16	GY	1680205C1	22	K47A	16	GY	1680205C1	23	PLUG	-	-	0453133C1	24	PLUG	-	-	0453133C1	25	PLUG	-	-	0453133C1	26	PLUG	-	-	0453133C1	27	PLUG	-	-	0453133C1	28	PLUG	-	-	0453133C1	29	PLUG	-	-	0453133C1	30	PLUG	-	-	0453133C1	31	PLUG	-	-	0453133C1	<table border="1" style="width:100%; border-collapse: collapse; font-size: x-small;"> <thead> <tr> <th>CAV</th> <th>CIR</th> <th>GAUGE</th> <th>COLOR</th> <th>TERMINAL</th> <th>SEAL/SLEEVE</th> </tr> </thead> <tbody> <tr><td>A</td><td>K34</td><td>16</td><td>TN</td><td>1661875C1</td><td>1661872C1</td></tr> <tr><td>B</td><td>K34-G</td><td>16</td><td>TN</td><td>1661875C1</td><td>1661872C1</td></tr> <tr><td>C</td><td>K34B-5V</td><td>16</td><td>TN</td><td>1661875C1</td><td>1661872C1</td></tr> <tr><td>D</td><td>K34A</td><td>16</td><td>TN</td><td>1661875C1</td><td>1661872C1</td></tr> </tbody> </table>				CAV	CIR	GAUGE	COLOR	TERMINAL	SEAL/SLEEVE	A	K34	16	TN	1661875C1	1661872C1	B	K34-G	16	TN	1661875C1	1661872C1	C	K34B-5V	16	TN	1661875C1	1661872C1	D	K34A	16	TN	1661875C1	1661872C1
CAV	CIR	GAUGE	COLOR	TERMINAL																																																																																																																																																																																																	
1	PLUG	-	-	0453133C1																																																																																																																																																																																																	
2	PLUG	-	-	0453133C1																																																																																																																																																																																																	
3	PLUG	-	-	0453133C1																																																																																																																																																																																																	
4	PLUG	-	-	0453133C1																																																																																																																																																																																																	
5	K34A	16	TN	1680205C1																																																																																																																																																																																																	
6	K34	16	TN	1680205C1																																																																																																																																																																																																	
7	K34B-5V	16	TN	1680205C1																																																																																																																																																																																																	
8	PLUG	-	-	0453133C1																																																																																																																																																																																																	
9	PLUG	-	-	0453133C1																																																																																																																																																																																																	
10	PLUG	-	-	0453133C1																																																																																																																																																																																																	
11	PLUG	-	-	0453133C1																																																																																																																																																																																																	
12	K23	16	TN	1680205C1																																																																																																																																																																																																	
13	PLUG	-	-	0453133C1																																																																																																																																																																																																	
14	PLUG	-	-	0453133C1																																																																																																																																																																																																	
15	PLUG	-	-	0453133C1																																																																																																																																																																																																	
16	PLUG	-	-	0453133C1																																																																																																																																																																																																	
17	PLUG	-	-	0453133C1																																																																																																																																																																																																	
18	PLUG	-	-	0453133C1																																																																																																																																																																																																	
19	K34-G	16	TN	1680205C1																																																																																																																																																																																																	
20	PLUG	-	-	0453133C1																																																																																																																																																																																																	
21	K47	16	GY	1680205C1																																																																																																																																																																																																	
22	K47A	16	GY	1680205C1																																																																																																																																																																																																	
23	PLUG	-	-	0453133C1																																																																																																																																																																																																	
24	PLUG	-	-	0453133C1																																																																																																																																																																																																	
25	PLUG	-	-	0453133C1																																																																																																																																																																																																	
26	PLUG	-	-	0453133C1																																																																																																																																																																																																	
27	PLUG	-	-	0453133C1																																																																																																																																																																																																	
28	PLUG	-	-	0453133C1																																																																																																																																																																																																	
29	PLUG	-	-	0453133C1																																																																																																																																																																																																	
30	PLUG	-	-	0453133C1																																																																																																																																																																																																	
31	PLUG	-	-	0453133C1																																																																																																																																																																																																	
CAV	CIR	GAUGE	COLOR	TERMINAL	SEAL/SLEEVE																																																																																																																																																																																																
A	K34	16	TN	1661875C1	1661872C1																																																																																																																																																																																																
B	K34-G	16	TN	1661875C1	1661872C1																																																																																																																																																																																																
C	K34B-5V	16	TN	1661875C1	1661872C1																																																																																																																																																																																																
D	K34A	16	TN	1661875C1	1661872C1																																																																																																																																																																																																
CHK	DATE	CHANGE	REV	REFERENCE	DRAWN	NAME																																																																																																																																																																																															
CNA1	11NOV09	INITIAL RELEASE.	A	62696P	310706	CIRCUIT DIAGRAM, PROSTAR																																																																																																																																																																																															
					RELEASE NO.	DATE	PART NO.																																																																																																																																																																																														
					62696P	25OCT09	AE08059995																																																																																																																																																																																														
						SHEET	005																																																																																																																																																																																														

Figure 393 Connector Composites (1093), (1155)