



Operator & Service Manual

Produce Plus Juicer





Operator & Service Manual Produce Plus Juicer

Copyright © John Bean Technologies Corporation 2015

JBT Corporation
400 Fairway Avenue
Lakeland, FL 33801
(863) 683-5411

Manual No. FNS-0004-060-EN



Safety Information	4
Safety Instructions	6
Technical Specifications.....	7
Important General Produce Information	9
Operating Instructions	13
Equipment Check	13
Juicing	14
Cleaning Instructions	16
Exploded View of Juicing Components	19
Maintenance	20
Troubleshooting	23
Juicer Final Assembly Listing	26
Cover Parts Listing.....	28
Feed Screw Assembly Listing	31
Drive Assembly Listing	32
Electrical Diagram & Assembly, 110 Volt Listing.....	34
Enclosure, Start Switch Assembly Listing	37
Electrical & Gearbox Sub-Assembly Listing	38
Electrical Panel Assembly Listing.....	39
Electrical Diagram & Assembly, 220 Volt Listing.....	40



IMPORTANT SAFETY INFORMATION

You can help prevent personal injury and/or property damage.

Please read this manual carefully before operating the JBT Corporation Juicer.
Do **NOT** attempt any operation until you understand exactly how the machine functions.

If uncertainty remains after studying this manual, please contact:

We're here to help. With proper handling, the JBT Corporation Juice Extractor will provide safe, efficient and convenient service for years to come.

	North America JBT Corporation 400 Fairway Ave Lakeland, FL 33801 USA Phone: +1 863 683 5411 Fax: +1 863 680 3672	Europe JBT Corporation, S.L. Julián Camarillo 26, 4º 28037 Madrid Spain Phone: +34 91 304 00 45 Fax: +34 91 327 50 03	South Africa JBT (Pty) Ltd. Koper Street Brackenfell Cape Town, South Africa 7560 Phone: +27 21 982 1130 Fax: +27 21 982 1136
	Brazil JBT Máquinas e Equipamentos Industriais Ltda. Av. Eng. Camilo Dinucci 4605 14808-900 Araraquara São Paulo Brazil Phone: +55 16 3301 2000 Fax: +55 16 3332 0565	Latin America JBT Corporation Carr. Mty-Salttillo Km 7—Bodega 4 Colonia Las Mitras Santa Catarina, NL Mexico 66350 Phone: +52 81 81 23 70 55 Fax: +52 81 81 23 70 54	Asia / Pacific JBT (Shanghai) Co. Ltd. Room 3002-3003 Haitong Security Building No. 689 Guangdong Road Shanghai 200001, China Phone: +86 21 6341 1616 Fax: +86 21 6341 0708

www.jbtcorporation.com

Revision History

Manual Code	Rev. No.	Date	Pages	Change History
FNS-0002-060-EN	A	11/01/14	Entire manual	Updates, modifications and alignment to JBT global version control and inventory standards
FNS-0002-060-EN	B	12/15/15	Entire manual	Addition of new Fresh'n Squeeze logo

Safety Labels

The safety labels shown below appear on the Juicer. They provide essential instructions on how to avoid possible hazards.

Please, for your safety: FOLLOW THOSE INSTRUCTIONS AT ALL TIMES.

Should the Juicer safety labels become damaged or unreadable, contact JBT Corporation for replacement labels.

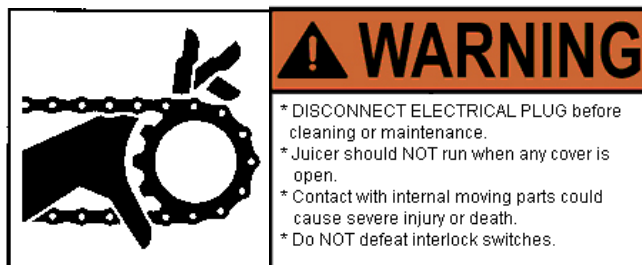



Safety Instructions

**Carefully review the following safety instructions.
Make them a habit when using the JBT Corporation Juicer.**

1. If Juicer continues to run when any access cover is open, interlock switch is defective.
Turn Juicer off immediately. Call for service.
2. Prevent unauthorized access to Juicer by locking all covers with supplied key.
3. Prevent unauthorized operation of Juicer by placing electrical plug inside cart door.
4. **NEVER** attempt to make any safety device inoperative.
5. **NEVER** operate or perform maintenance or repair work on Juicer when taking any kind of drug or sedative, when under the influence of alcohol, or when fatigued.
6. **ALWAYS** check adjustment of all nuts, bolts, and screws after installation, repair, or periodic maintenance.



TECHNICAL SPECIFICATIONS

Produce size:	No restrictions, up to pineapple
Hopper capacity:	12 - 15 lb. depending on produce
Reservoir capacity:.....	5 qts.
Waste container capacity:	40 lbs.
Speed:.....	4 minutes for full hopper (12 – 20 gallons/hour)

ELECTRICAL SPECIFICATIONS

115V 60Hz Single Phase 20 AMP Service

Dedicated line needed for Juicer.

Use 12 GA. wire minimum up to 100 ft. from main breaker panel, 10 GA. up to 200 ft.

SHIPPING SPECIFICATIONS

Height: 63-1/2"

Width: 24"

Depth: 29"

Weight: 350 lbs.



GENERAL INFORMATION

The Fresh'n Squeeze® Produce Plus Juicer is designed to provide years of dependable service with significantly less downtime and maintenance. It uses a unique patented design to extract every available amount of juice from the produce. This Juicer was designed to run high quality fruits and vegetables mentioned on Page 10 only. To process citrus use our Fresh'n Squeeze® Multi-Fruit Juicer.

CERTIFICATIONS

UL - Approved

CUL - Approved (Canada)

NSF (National Sanitation Foundation) - Approved



IMPORTANT GENERAL PRODUCE INFORMATION

Juicing fruits and vegetables requires that the highest quality standards be maintained. This is also important for handling all produce and salad bar items. Failure to maintain these high standards can lead to the growth of bacteria which can be harmful to your customers. By following the procedures in this manual you can operate a safe and profitable juicing business.

CONDITION OF PRODUCE

Use only fresh, high quality produce from reliable vendors;

DO NOT use rotten, spotted, molded, or old fruit for juicing.

DO NOT use juicer as a cull disposal program for your produce.

DO NOT juice skin type produce (tomatoes) with splits in them. All of this will increase harmful bacteria growth; such as, Salmonella, E. Coli, etc.

DO wash all produce with clean, fresh, drinking water only.

DO keep all produce cold (40°F). This will inhibit the growth of harmful bacteria.

DO keep in cooler until ready to juice.

JUICE HANDLING

Make sure that the containers and lids for filling are sanitized. Also, it is best to use the smallest containers possible to prevent spoilage before consumption. Filled containers should be refrigerated (34°- 40°F) immediately after filling; if put on ice, make sure entire container is submerged. Limit shelf life for produce juice to one day in the store. Juice every day; do not produce excessive juice inventory.

Juice must be consumed within three days.



GENERAL PRODUCE INFORMATION

NOTE: All fresh produce must be washed thoroughly and kept refrigerated before juicing to maintain high juice quality standards. Culls must never be used.

Types of produce

Apples

All types; we recommend Washington Apples. Best if three different types are blended equally, e.g. Red Delicious, Golden Delicious & Granny Smith.

Carrots

All types; but, California varieties are the best. Remove green portion. Some extra large diameter (horse) carrots may have to be cut up.

Pineapple

Remove stem and peel.

Grapes

All types and blends. Remove stems to get a less bitter taste. Seedless grapes are preferred.

Celery

Remove top leafs and bottom core.

Tomatoes

Don't use low acid varieties and make sure there are no splits in skin. Both conditions may allow fast, harmful, bacteria growth.

Pears, Nectarines, & Peaches

Remove all pits; may not give satisfactory juice due to thick consistency, but can be used for blending with other fruits like apples and oranges.

Strawberries, Cranberries, Blueberries

All types.

Kiwi

Peeled only.

Rhubarb, Spinach

For blending with other juices only; do not drink unblended because of their high oxalic acid content. Never use Rhubarb leaves due to high oxalic acid.

Melons

Caution: Never juice melons because of their high pH which encourages harmful bacteria growth such as Salmonella.

Citrus

Not recommended due to the high peel oil content of the skin. Use the Fresh'n Squeeze™ Multi-Fruit Juicer for citrus.

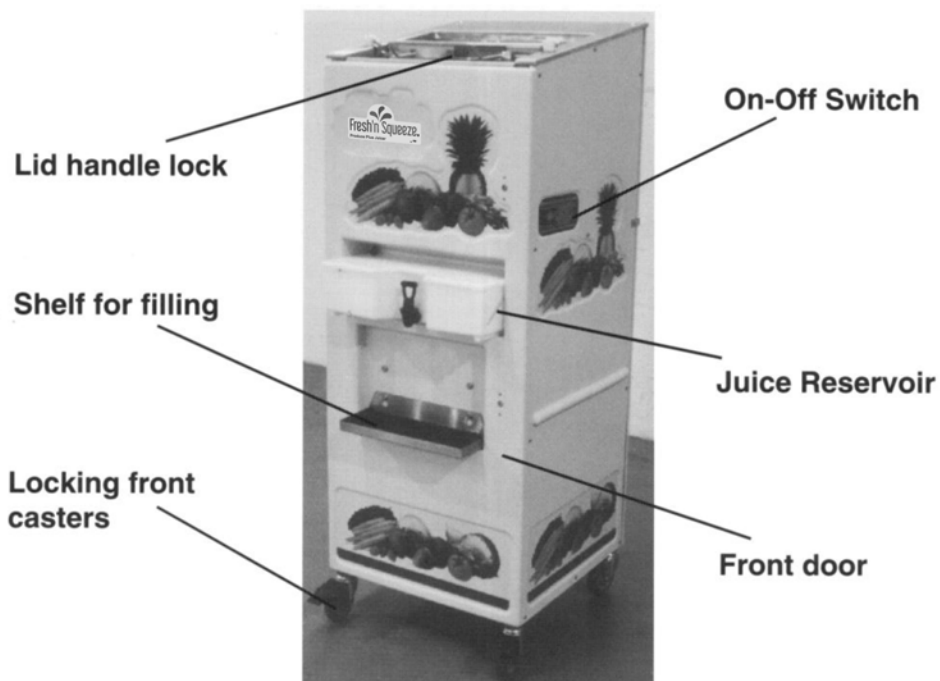

Figure 1a. Produce Plus Juicer

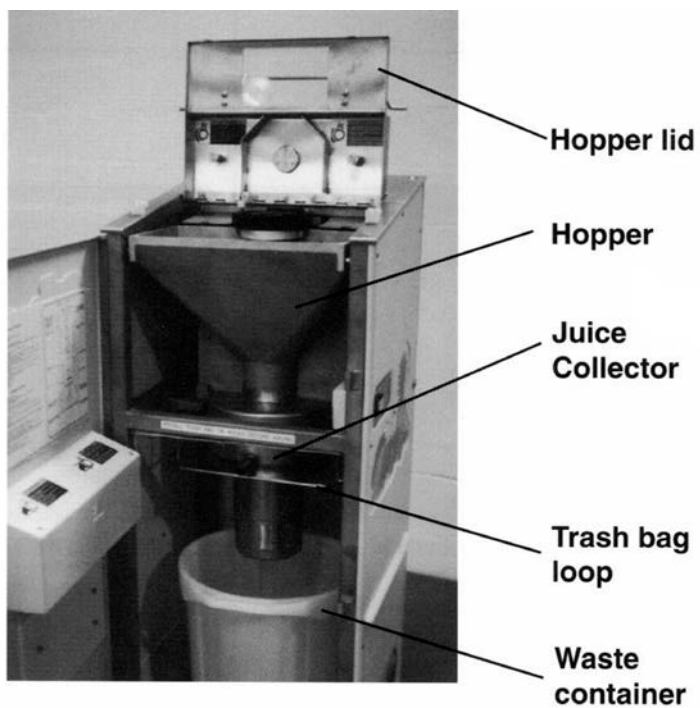

Figure 1b. Juicing Components Assembly



Figure 1c. Lifting out hopper



Figure 1d. Lifting screw out of hopper

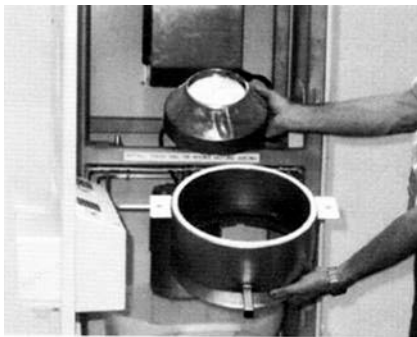

Figure 1e. Juice collector



Figure 1f. Trash bag installed

OPERATING INSTRUCTIONS

EQUIPMENT CHECK

Before plugging the JBT Corporation Juicer into an electrical outlet, the following steps must be performed:

1. **Make sure the juicer is clean per cleaning instructions.**
2. **Juice only in a clean, cool, dry location. The produce department sales floor is typically the best location.**
3. **Locate the Juicer on a level surface.**
This will prevent fruit feed problems.
4. **Lock both front casters.**
To lock, push down on caster with foot. To unlock, push again with foot.
5. **Check waste container.**
Open cart door to verify that waste container is in place. Make sure a plastic bag is attached to the hooks above the waste container (recommend the "Hefty Cinch Sak[®]", 30 gallon capacity or equivalent, drawstring type).
6. **Check juicing components.**
Use key to unlock juicing components cover. Open cover and check that juicing components are installed and securely fastened. See Figure 1b.
7. **Close and lock all access covers.**
There are two separate access covers: Hopper cover and juicing components door cover.

Never operate Juicer unless all covers are in place.
8. **Make sure juice reservoir is firmly in place.**
9. **Make sure juice reservoir faucet is in the closed position.**
10. **Check the hopper for foreign objects.**
Remove any foreign objects found in the hopper.
11. **Make sure floor area around juicer is clean and free of obstructions and water.**

When water is necessary, wear appropriate non-slip footwear.



OPERATING INSTRUCTIONS

Juicing

Wash hands thoroughly before Juicing.

1. **Bulk Feed**

Unlock and open the hopper cover. Dump up to 15 lbs. of produce into the hopper. Do not force lid closed; remove some produce, if hopper is too full.

2. **Turn on Juicer**

Push the "ON-OFF" button to "ON" position.

3. **Automatic Shut-Off**

Juicer may shut off with produce in hopper due to high juice level in reservoir. There is a high level shut-off to prevent the overflow of juice.

4. **Turn-off Juicer**

Push the "ON-OFF" switch to the "OFF" position.

5. **Stir Juice**

Use stirrer handle to stir juice in reservoir before filling containers. Fill containers immediately. DO NOT let juice stand in the reservoir.

6. **Discard the first 1 - 2 ounces of juice produced.**

This will ensure that any prior contamination or residue is eliminated.

7. **Taste each batch of juice for quality before filling containers.**

Discard poor tasting product.

8. **Fill Containers**

Place sterile container under juice reservoir faucet. Open faucet by depressing handle until container is full. Fill shelf has two adjustments for short and tall containers. Cap juice immediately and refrigerate at 34°-40°F. All bottles must be coded with three days shelf life maximum. **(See Juice Handling Section)**

OPERATING INSTRUCTIONS

9. Juicing Different Produce

It is not necessary to fully clean Juicer if immediately switching to another type of juice. Fill a one gallon container with drinking water. Open hopper and use 1/2 gallon water to rinse left-over product residue. Close hopper and turn on juicer. Pour the remaining 1/2 gallon water into funnel type hole on top of hopper lid. Remove water from reservoir and rinse thoroughly. Proceed to juice the next type of produce.

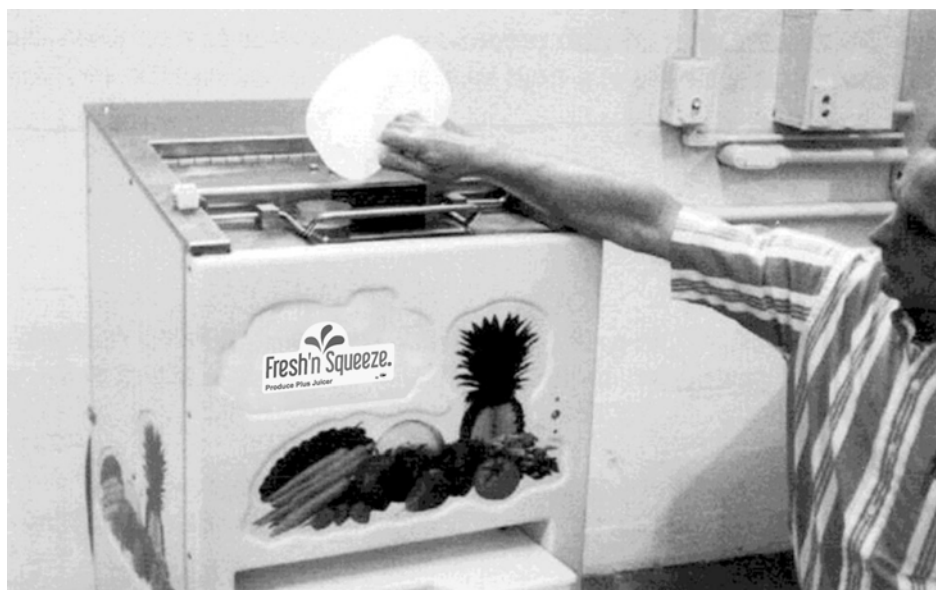

Water being poured into hole in hopper

10. Clean Juicer

If finished juicing, clean Juicer immediately.
(See next page for cleaning instructions.)



CLEANING INSTRUCTIONS

**Thorough cleaning of all Juicer components is a necessity.
Do not take any short-cuts in cleaning or sanitizing.**

ALWAYS follow cleaning and maintenance schedules in this manual to prevent equipment damage.

Clean Juicer immediately after juicing. Use a clean soft towel or sponge to wipe equipment parts. **Never use abrasive pads such as steel wool, etc.**

The recommended cleaner is JBT Corporation brand CorKlean. CorKlean is a low-foaming alkaline equipment cleaner. It is safe on aluminum, 100% water soluble and free rinsing. CorKlean has been especially formulated for cleaning food processing equipment and is USDA accepted. Follow instructions on cleaner label for dilution.

1. **Turn-off Juicer.**
2. **DISCONNECT ELECTRICAL PLUG.**

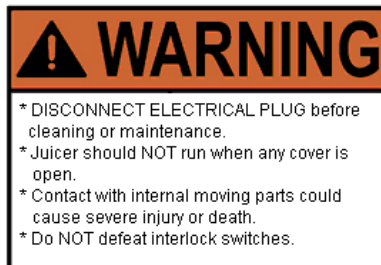

3. **Pull Juicer to clean-up area, if one is available.**



CLEANING INSTRUCTIONS

4. a. With both hands lift hopper up and out, with plastic feed screw in it.
- b. Remove juice collector pan.

CAUTION: TEETH ON GRATER ARE SHARP.

- c. Remove screen assembly; remove large pieces of product from inside of screen and place into waste container.
- d. Remove trash bag from hooks; then, remove waste container.
- e. Remove juice reservoir and fill shelf.
5. If possible, hose down inside and outside of Juicer with hot drinking water; if not, with waste container in place, sponge or spray juicing area with cleaning solution. Rinse with hot drinking water. Be sure to clean stainless steel drive gear. Wipe dry.
6. With a hose or spray nozzle, rinse off all juicing components with clean hot water. **A hard spray on screen assembly** will remove all stuck product. Make sure to remove plastic feed screw from hopper.
7. Prepare a cleaning solution of clean hot water and CorKlean in a sink or large container. . Follow instructions on cleaner label for dilution..
8. Use brush provided to scrub all juicing components in the solution; (never use a wire brush). Pay particular attention to cleaning the screen and grater plate. Be careful, the grater teeth are sharp. If stains are not easily removed, allow juicing components to soak for ten minutes or longer.
9. Rinse all juicing components with clean hot water; then, thoroughly rinse with sanitizer solution per manufacturer's mixing directions and safety precautions. Allow to air dry.
10. Re-assemble Juicer per assembly instructions.



CLEANING INSTRUCTIONS

11. Install trash bag onto loop and hooks.
12. Make sure waste container is in place.
13. Re-install reservoir and fill shelf with grate.
14. Air dry by turning Juicer on for a minute or two.
15. If reservoir or covers become stained, or mold appears on inside of covers, clean with appropriate disinfectant cleaner. Follow manufacturer's directions and safety precautions. Rinse thoroughly with water.
16. Clean grease marks from covers. Follow manufacturer's directions and safety precautions.

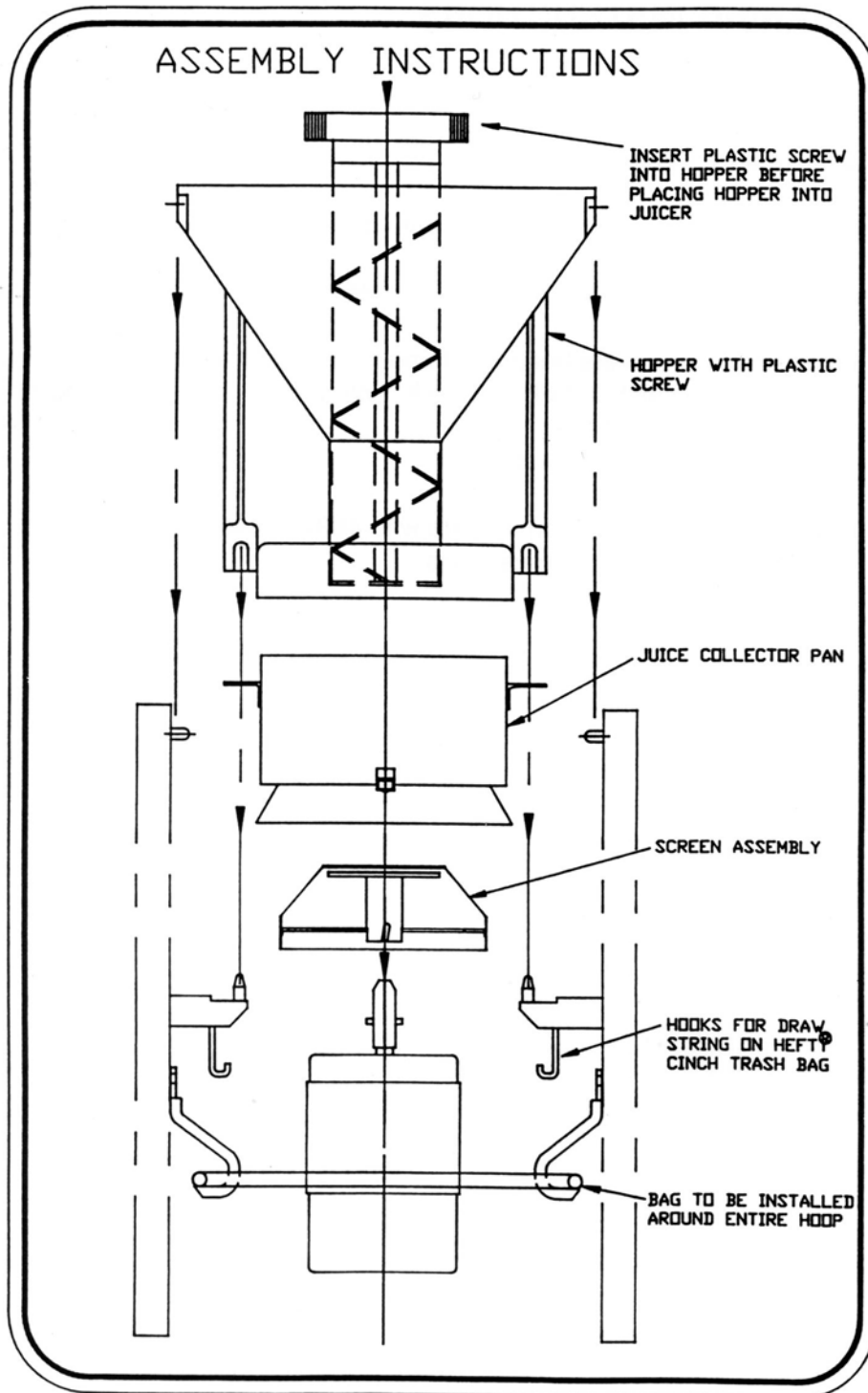



MAINTENANCE

**Before performing any maintenance,
DISCONNECT ELECTRICAL PLUG.**

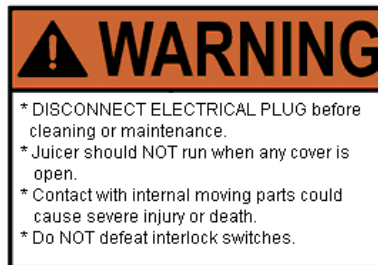

Juicer requires no lubrication.

DO NOT LUBRICATE ANY BEARING, ROD END, OR SHAFT.

After every juice run:

1. **Check screen assembly for damage, or missing mounting screws. Replace if necessary.**
 - a. **Screen removal:**

With a flat type screwdriver, remove (4) mounting screws as shown in photo.

CAUTION: Teeth on grater are sharp



Removing mounting screws

MAINTENANCE

b. Screen Installation:

Reassemble, making sure screws are securely tightened. Reinstall in Juicer. Jog Juicer to make sure there is no interference.

2. **Check grater on screen assembly for missing teeth.** If any are missing, replace immediately. **DO NOT** use.
3. **Check grater on screen assembly for worn teeth.**
If outer rows of teeth are almost completely worn down, replace grater.
4. **Check large plastic gear on top of feed screw for damage.**
 - a. If burred, use knife or file to dress-up corners and edges.
 - b. If teeth are missing, replace gear.
 - c. Replace by removing four socket head screws.
DO NOT over-tighten when reassembling.
5. **Check large plastic feed screw for damage.**
 - a. If burred, use knife or file to dress-up.
6. **Check for damaged or missing feed screw tip.** Replace if less than 1/32" thick. Remove by turning tip to the left.

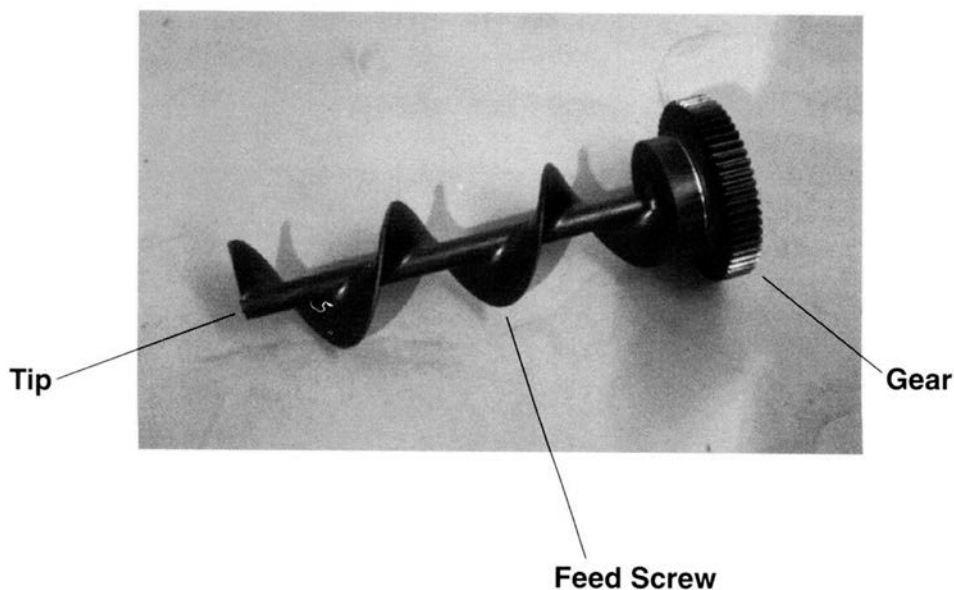



MAINTENANCE

7. **Check motor drive pin.** Make sure it is in place and centered in shaft.

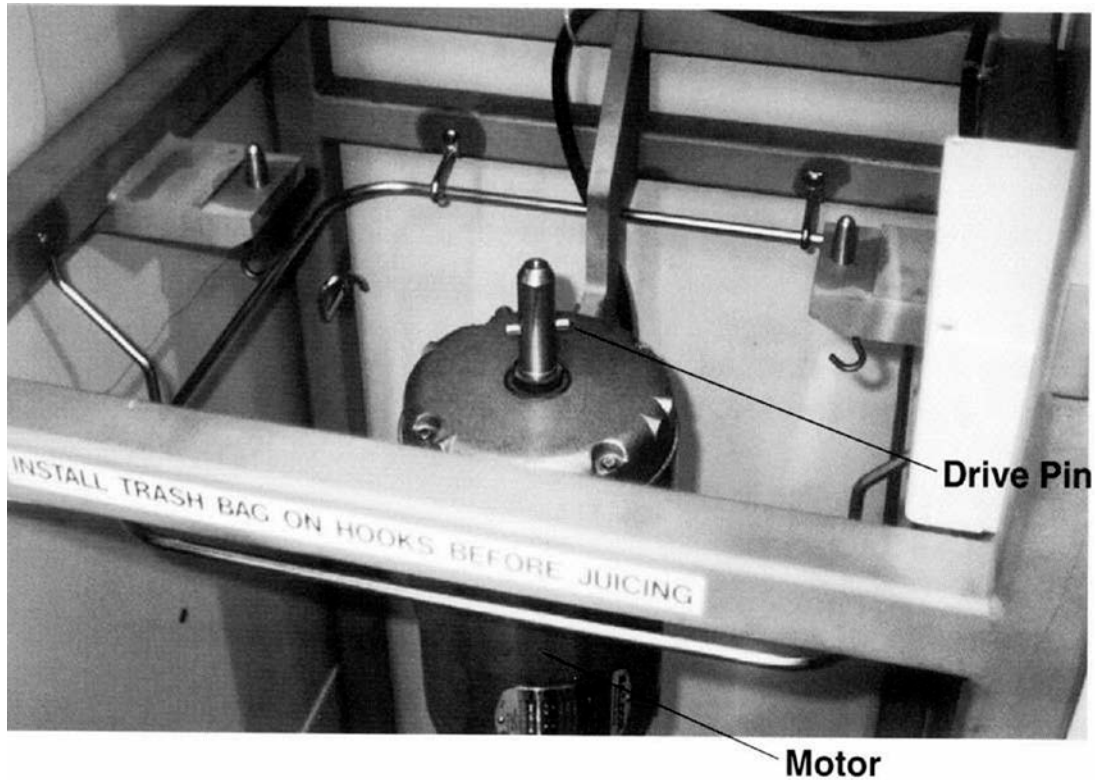

8. **Check for loose or missing nuts and bolts.**
 - a. Tighten or replace nuts and bolts as necessary.
ALWAYS use JBT Corporation recommended spare parts.

TROUBLE SHOOTING

CAUTION: NEVER reach into moving parts to clear a jam, no matter how simple it seems.

Juicer will not start.

1. Extractor is not plugged into electrical outlet.
2. Building circuit breaker has tripped.
3. All covers are not completely closed including cart and back (cover).
4. High level in reservoir has shut juicer off. Shut off level is approx. 3/4 full.
5. Equipment is jammed.
Call for service.
6. "ON-OFF" switch is defective.
Call for service.

Juicer will not start; but, buzzing sound comes from "ON-OFF" switch.

1. Overloaded circuit.
Machine needs to be on separate (its own) electrical circuit.
2. One or more covers partially closed causing intermittent contact of interlock switch.
3. Low voltage to machine.
Use 110 volts minimum.

Juicer starts, but shuts off.

1. Building circuit breaker is not rated for 20 Amps.
2. Extension cord or wiring is too long.
Eliminate extension cord or use heavier gauge wire. (See "Specifications")
3. All covers are not completely closed.
Close any open covers.
4. One or more covers has a defective interlock switch.
Turn off Extractor. Call for service.
5. Juice in reservoir has reached max. level - approx. 3/4 full.

**Juicer runs with covers open or off.
Turn off Juicer. Call for service.**



Produce Bridging in Hopper

1. Hopper has dirt or wax built-up.
Clean Hopper.
2. Extremely large carrots.
Break into two pieces before loading into hopper.

Vibration Noise

1. Screen assembly is off balance due to large amount of matted/dry product (especially if running celery or pineapple) on side of screen.
Remove screen assembly and remove dry product. Reassemble.

Scraping Noise

1. Juicing components not assembled properly and/or product on mounting surfaces.
Check, clean, and re-assemble.
2. Foreign object on grater (seed, rock, etc.)
Remove Hopper and remove object.

Large Pieces of Product in Juice

1. Juicing components not assembled properly
Clean and re-assemble.
2. Damaged screen assembly
Check for holes and replace if necessary.



TROUBLESHOOTING

Waste Product on Floor

1. Trash bag not installed or not installed properly. **See photo on page 12.**

Juice on Floor

1. High level shut off in reservoir not adjusted properly.
Adjust so juicer shuts off before juice level gets to hole in back of reservoir - approx. 3/4 full.

Hopper Cover Will Not Stay in up Position

1. **Call For Service.**



Juicer Final Assembly 060-05000-R

Item	Qty	Part Number	Description
1	1	060-05004-F	Cover Parts Details See Pages 28 through 30
2	1	060-05067-01	Feed Screw Assembly Details See Page 31
3	1	060-05051-B	Hold Down
4	2	004-352-280	Screw, Cap Hex, 1/4-28 x 3/4" Lg, S.S.
5	2	060-05081-B	Hopper Lid Retainer
6	1	060-05105-C	Hopper Lid
7	4	004-501-060	Screw, Cap Hex Head, S/L, 1/4-20 x 1" Lg, S.S.
8	1	007-055-526	Clevis
9	1	009-715-098	Gas Spring
10	2	060-05029-B	Hold Down, Hopper Handle
11	1	060-05130	Hopper, S.S. (replaces 060-05013)
12	1	060-05042-C	Juice Collector
13	4	004-385-009	Screw, Mach, Flat Head, #6-32 X 1/2" Lg, S.S.
14	1	060-05088-C	Grater Disc & Hub Assembly – Includes Item 14a
14a	1	060-05087-C	Grater Disc only
15	1	060-05037-C	Screen
16	1	060-05058-B	Key Ring & Key
17	1	060-05028-C	Handle, Hopper Lid
18	6	004-401-022	Screw, Mach., Truss Head, #10-24 x 3/8" Lg, S.S.
19	1	060-05055-B	View Window, Hopper
20	4	004-816-060	Washer, Plain, 1/4"
21	1	060-00120-B	Sign, Warning, Covers
22	1	060-00176-B	Sign, Warning, Spanish
23	1	060-00082-B	Label, Hopper English (Not Shown)
25	2	004-111-035	Nut Hex, 1/4-28, S.S.
26	1	009-080-327	Brush, Veg. (Not Shown)
27	1	009-080-328	Brush, Valve (Not Shown)
28	1	009-425-020	Spare Key (Not Shown)
29	1	060-05080-B	Label, Cord
30	1	004-111-040	Nut Hex, 5/16-18, S.S.
31	1	060-05083-C	Waste Chute
32	3	004-352-312	Screw, Cap Hex, 5/16-18 x 5/8" Lg, S.S.
33	4	004-806-050	Lock Washer, 1/4"
34	1	060-02087-B	Safety Key
35	2	004-392-174	Screw, Mach., Pan Head, #8-32 x 1/2" Lg
36	2	060-02059-B	Button Nut, #8-32
37	1	006-200-481	Safety Key, Angled
38	2	004-401-022	Screw, Mach., Truss Head, #10-24 x 3/8" Lg, S.S.
39	1	060-00082-B	Label, Hopper Spanish (Not Shown)

After 2013:

4	2	060-05137	Threaded Rod, Hopper Lid
10	1	060-05136	Handle, Hopper Lid
25	2	004-116015	Nut Hex, 1/4-20, S.S.

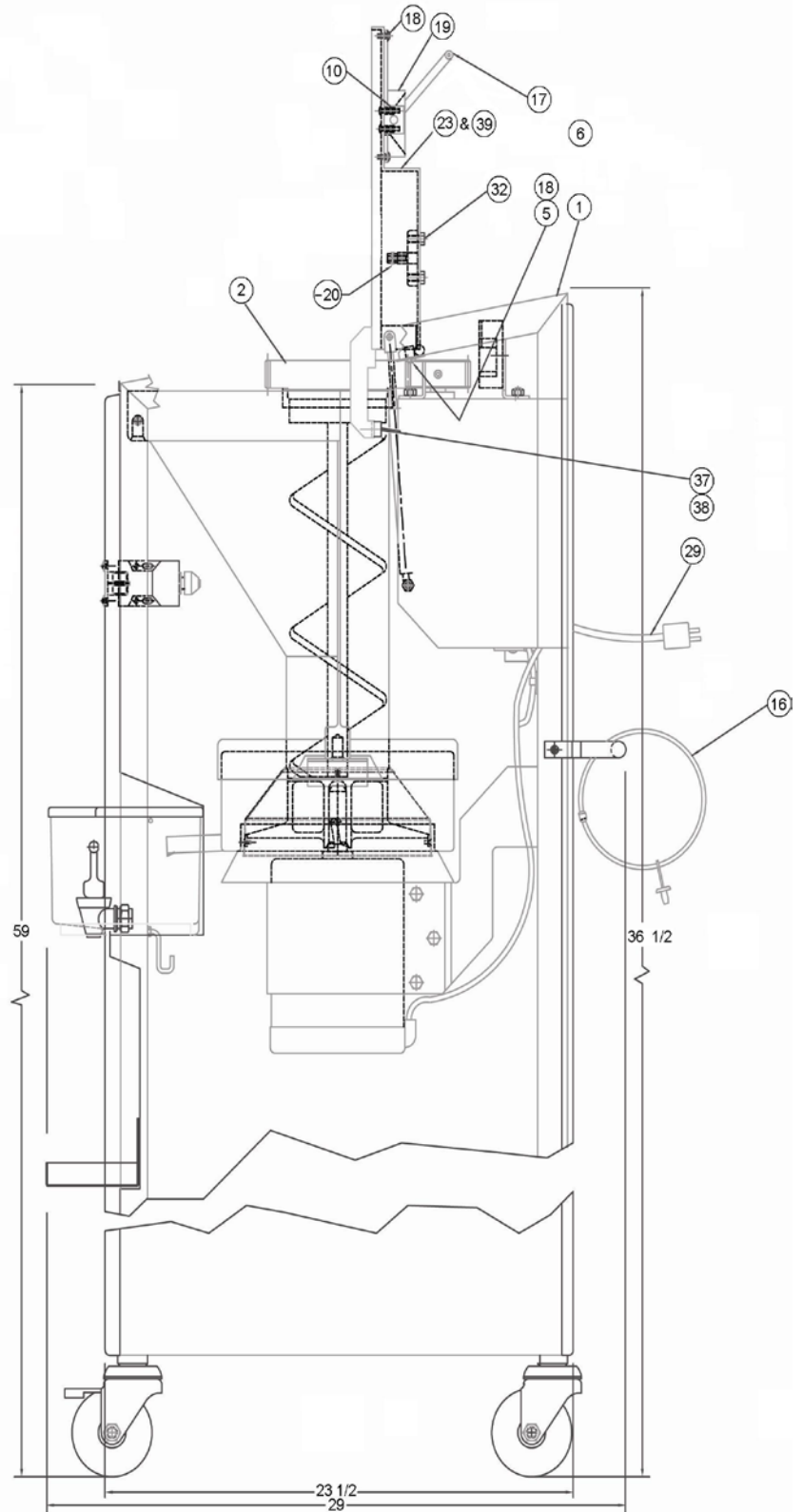
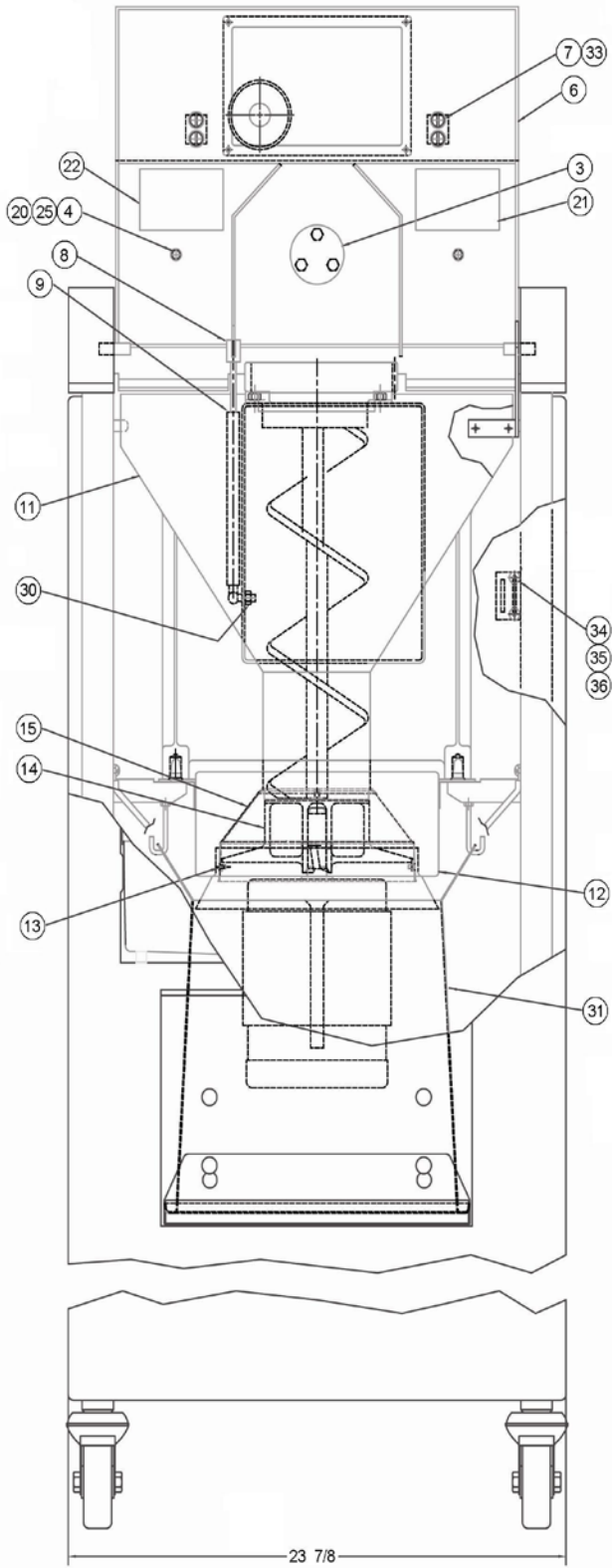



Cover Parts 060-05004-F

Item	Qty	Part Number	Description
1	1	060-05002-F	Drive Assembly Details See Pages 32 through 33
2	1	060-05027-C	Float Frame
3	1	009-210-013	Float
4	1	060-00140-B	Magnet Holder
5	1	006-210-291	Magnet
6	1	060-05026-C	Reservoir Stirrer
7	4	060-05021-B	Pin, Shelf Hanger
8	1	060-05019-C	Shelf, Fill Container
9	1	060-05020-C	Grate, Fill Container
10	1	060-05063-B	Faucet
11	1	060-05073-B	Jam Nut
12	1	009-210-018	Washer
13	1	060-05006-C	Lid, Juice Reservoir
14	1	060-05005-D	Reservoir, Juice
15	1	060-05011-F	Door
16	32	004-401-032	Screw, Mach., Truss Head, #10-24 x 1" Lg, S.S.
17	1	060-05043-B	Access Plate, Back Cover
18	1	004-156-041	Nut, Hex, Self-Locking, #10-24, S.S.
19	1	060-05008-C	Cover, Back
20	1	060-05056-D	Cover, Top
21	1	060-05010-C	Cover, Right Side
22	1	060-05009-C	Cover, Left Side
23	1	060-00148-B	Label, Trash Bag
24	4	004-156-049	Nut, Hex, Self-Locking, 1/4-20, S.S.
25	1	009-092-020	Waste Container
26	1	060-05057-C	Handle
27	2	060-05030-B	Lid Handle Lock
28	4	004-401-033	Screw, Mach., Truss Head, #10-24 x 1-1/4" Lg, S.S.
29	6	004-816-052	Washer, Plain #10, S.S.
30	13	004-401-022	Screw, Mach., Truss Head, #10-24 x 3/8" Lg, S.S.
31	1	060-00122-B	Label, Moving Juicer
32	1	015-03935-B	Name Plate, Domestic
32	1	015-03938-B	Name Plate, Export
33	8	004-265-016	Pop Rivet, 1/8 x 1/4
34	1	015-03934-B	Patent Plate
35	1	060-05068-C	Assembly Decal
36	1	060-05069-C	Cleaning Decal
37	1	060-05076-B	Mounting Plate for Decals
38	1	060-05072-B	Label, Wash Produce
39	2	009-395-017	Plastic Knob
40	2	004-397-142	Screw, Mach., Round Head, #10-32 x 1/2" Lg, S.S.
41	2	004-816-052	Washer, Plain, #10
42	1	060-00175-B	Label, Moving Juicer, Spanish

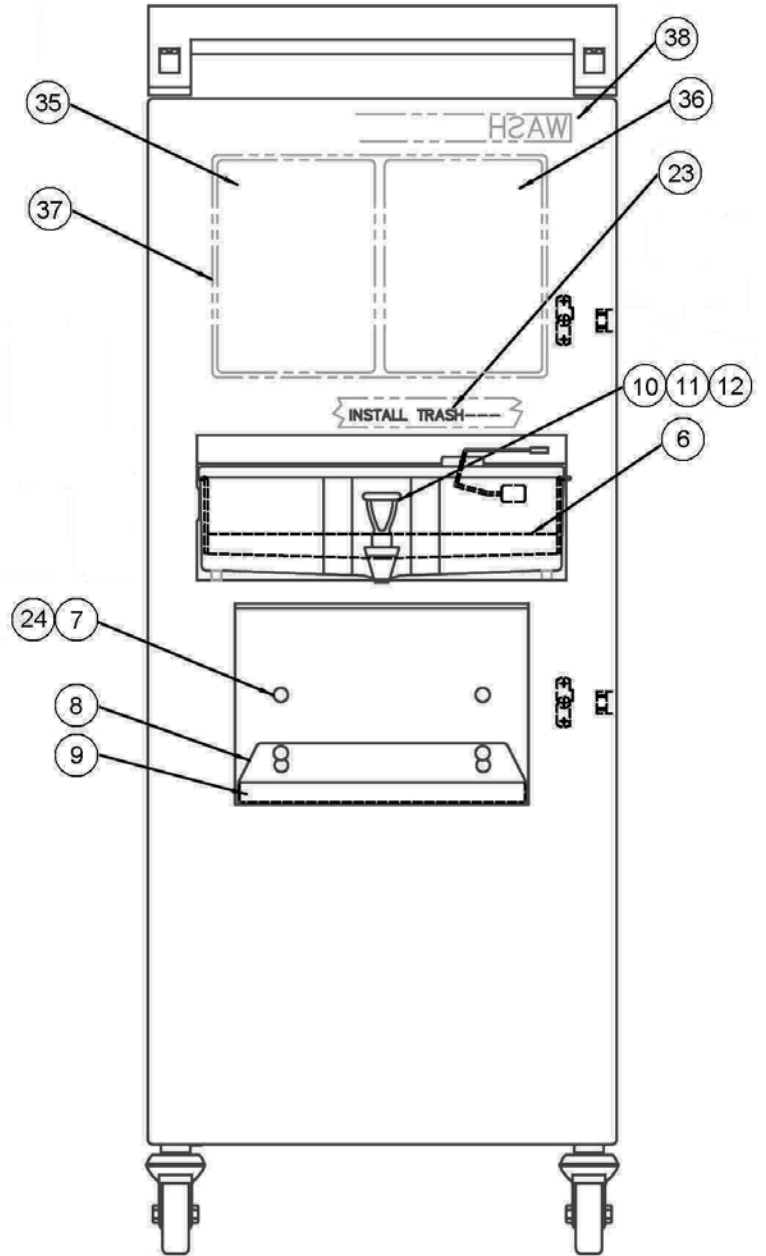
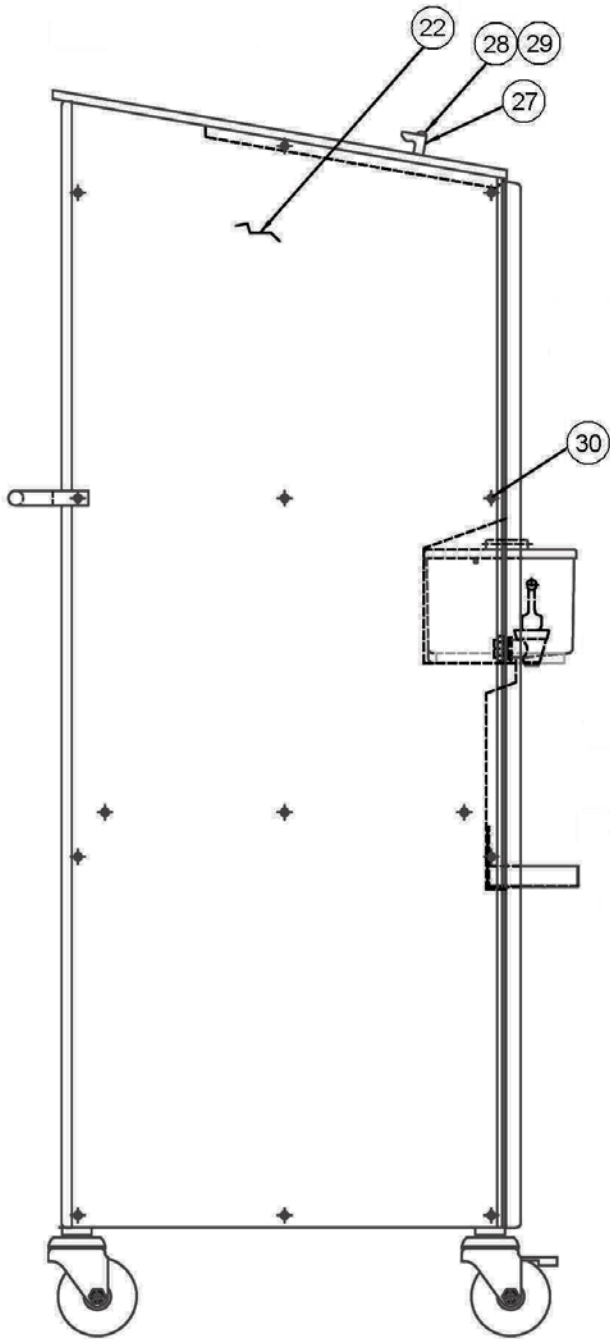

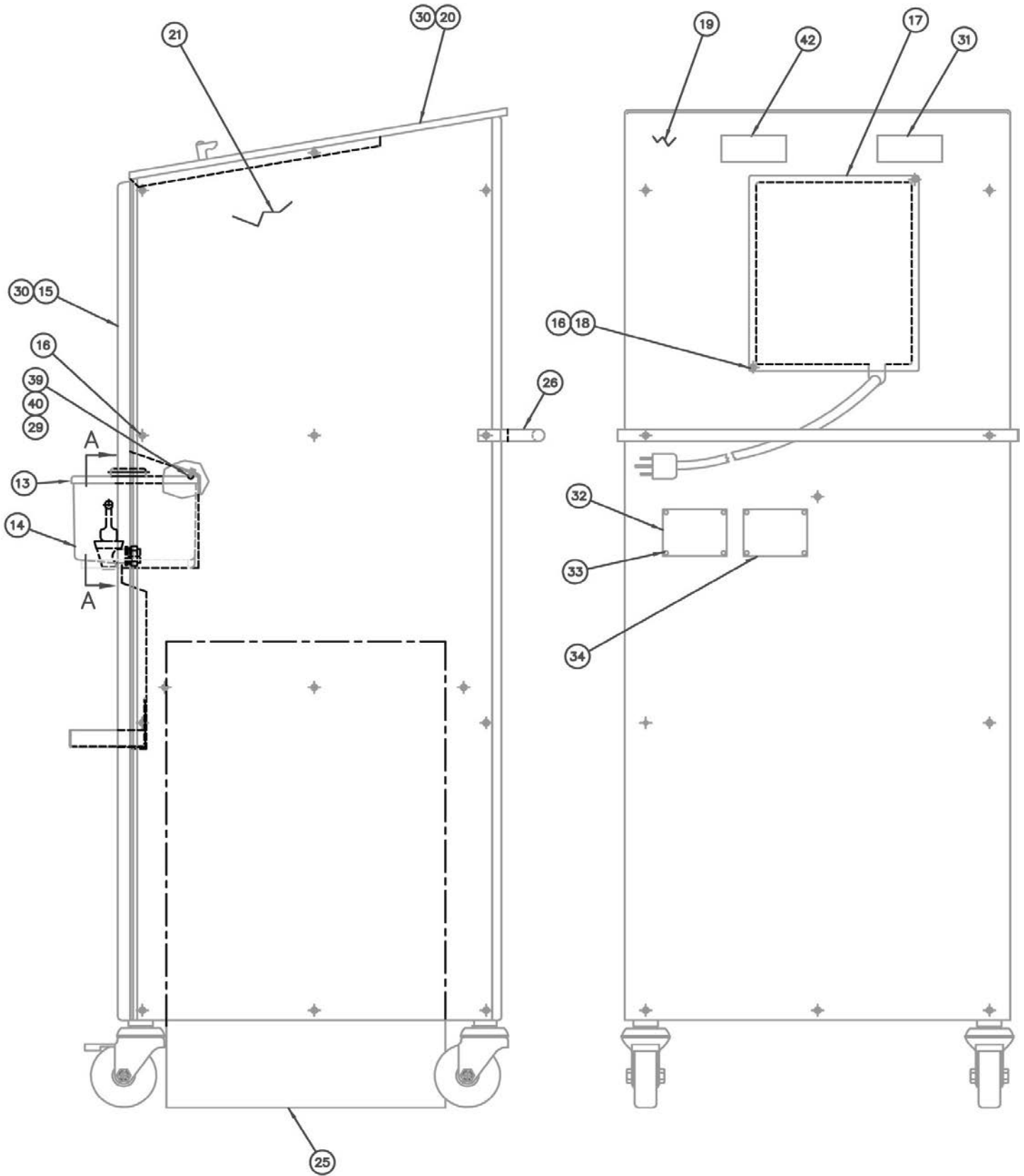

Feed Screw Assembly 060-05067-01

Item	Qty	Part Number	Description
1	1	060-05045-D	Feed Screw
2	1	060-05050-B	Tip, Feed Screw
3	1	060-05031-B	Gear, Feed Screw
4	4	004-356-117	Screw, Cap, Socket, 3/8-16 x 2" Lg, S.S.

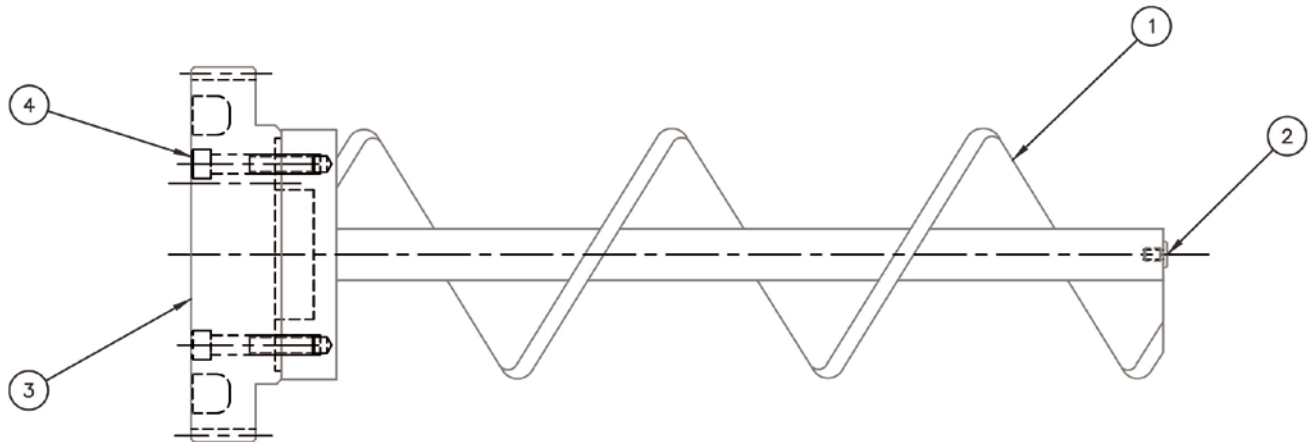



Drive Assembly 060-05002-F

Item	Qty	Part Number	Description
1	1	060-05003-F	Frame Weldment
2	2	009-080-530	Caster
3	2	009-080-531	Caster w/ Brake
4	1	060-05099	110V/60Hz Field Replacement Motor
5	1	060-05007-C	Motor Clamp
6	3	004-352-398	Screw, Cap Hex, 3/8-16 x 1-1/4" Lg, S.S.
7	3	004-111-048	Nut Hex, 3/8-16, S.S.
8	1	060-05079-B	Pin, Motor Drive
9	2	060-05077-B	Bag Hook
10	4	004-111-022	Nut Hex, #10-24, S.S.
11	2	060-05048-B	Pin- Hopper Lower
12	1	060-05066-D	Electrical Assembly, 110 Volt, 60 Hz Details See Pages 34 through 36
13	6	004-401-022	Screw, Mach, Truss Head, #10-24 x 3/8 Phillips, S.S.
14	1	060-05047-D	Bag Loop
15	2	060-05049-B	Pin, Hopper Upper
16	2	004-506-089	Screw Cap Socket, 1/4-20 x 5/8" Lg, Nylok, S.S.
17	1	060-05052-B	Waste Container Hanger
18	2	060-05078-B	Cleaning Tool Hook
21	1	060-05108-B	Slinger, Motor Shaft
22	3	004-806-070	Washer, Lock, 3/8" (Motor-3 Required)

220V/50Hz Motors:

12	1	060-05066-D	Electrical Assembly, 220 Volt, 50 Hz Details See Pages 40 through 42
20	1	060-05102	220V/50Hz Field Replacement Motor

Tools for Motor Replacement:

1	060-05090	Motor Mounting Fixture
1	060-05142	Grater, Gap Tool, Gage
1	060-05143	Hub Grater Drive Tool
1	060-05144	Hub/Disk Assembly
1	060-05145	Hopper Spacer, Gage

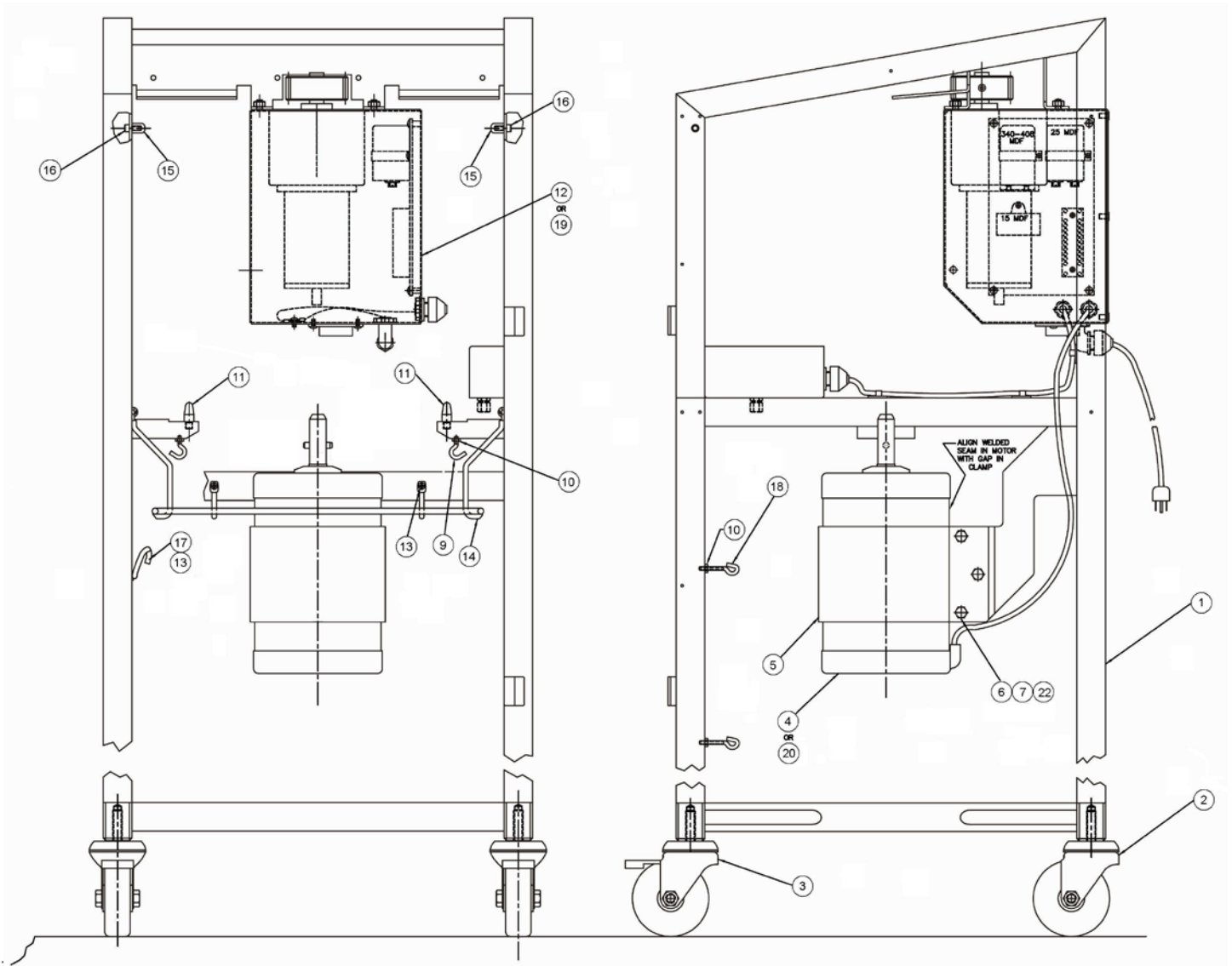



Electrical Diagram & Assembly, 110 Volt 060-05066-D

Item	Qty	Part Number	Description
2	5	009-097-003	Cable Tie
4	1	060-05060-C	Enclosure, Start Switch Assembly
5	2	004-401-022	Screw Mach., Truss, #10-24 x 3/8" Lg, Phillips, S.S.
6	1	060-05074-B	Cord Type SJO 4 Cond 16 GA
7	1	006-270-141	Cable Mount Small
8	1	060-05065-C	Electrical & Gearbox Sub-Assembly
9	3	006-220-014	Terminal, # 10 Ring End 10-12 GA.
10	4	004-156-063	Nut Hex, 5/16-18 Self-Locking, S.S.
11	1	006-210-290	Proximity Switch (NC)
12	1	006-080-071	Power Cord #12/3 x 10'-0" Lg
13	4	004-111-022	Nut, Hex, #10-24, S.S.
14	4	004-816-070	Washer Plain, 5/16, S.S.
15	2	006-221-082	1/4 Spade Term 16 GA
16	1	006-221-084	1/8 Spade-Fem-20 GA
17	1	004-397-129	Screw Mach., Round Head, # 10-24 x 1/4" Lg
18	4	009-654-002	Cable Retainer
19	2	006-200-482	Switch, Interlock, Schmersal #AZ15
20	1	007-143-370	Fitting, Strain Relief, 90°
21	1	007-143-395	Fitting, Strain Relief, Straight
22	1	006-080-073	Cord, 14/2 x 42"
23	1	006-080-073	Cord, 14/2 x 27"
24	2	004-401-026	Screw, Mach., Truss Head, #10-24 x 5/8" Lg, S.S.
25	4	004-816-052	Washer, Plain, #10
26	1	004-401-032	Screw, Mach., Truss Head, #10-24 x 1" Lg, S.S.
27	2	004-440-011	Screw Type "F", #6-32 x 1/2" Lg, S.S.
28	1	007-143-474	Fitting, Strain Relief, 90°
29	1	007-143-396	Fitting, Straight Strain Relief

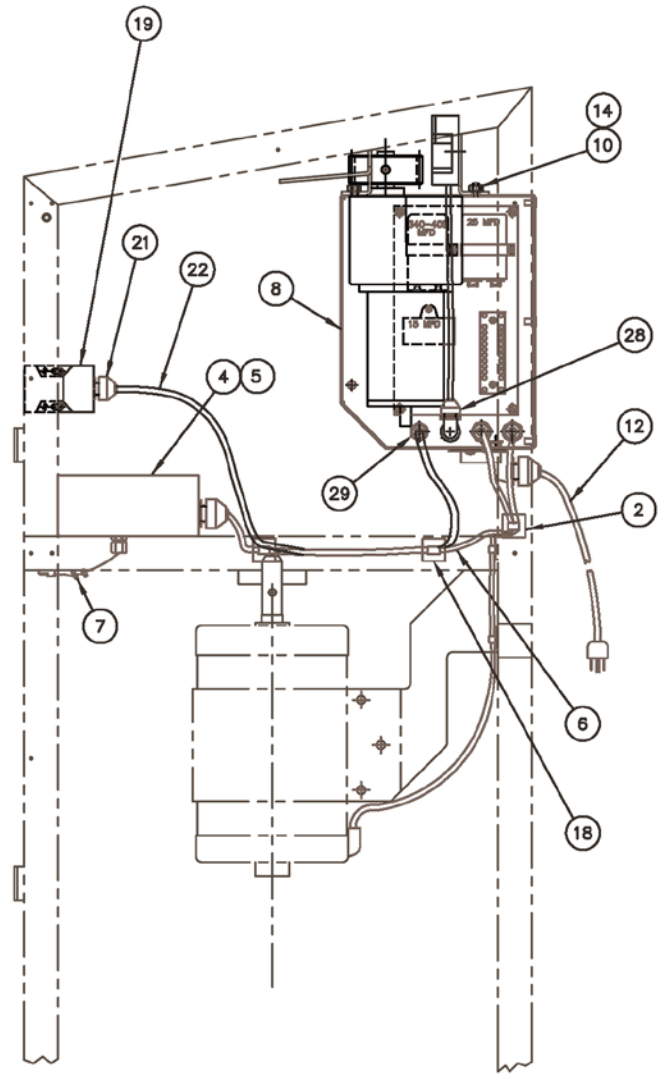
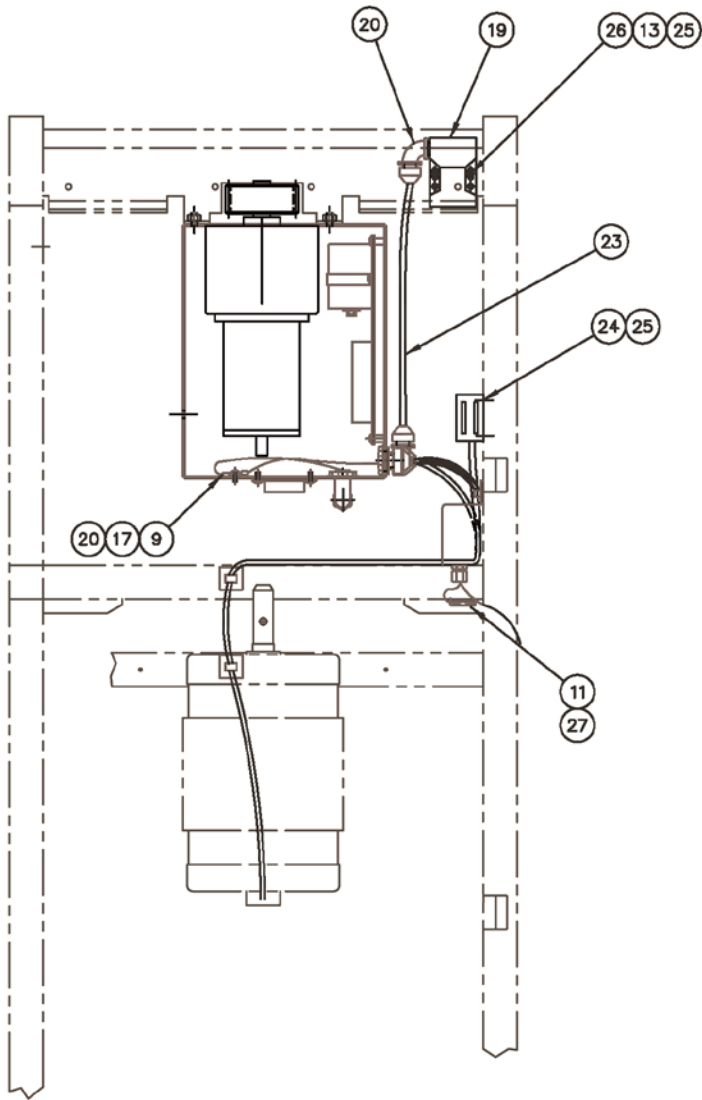

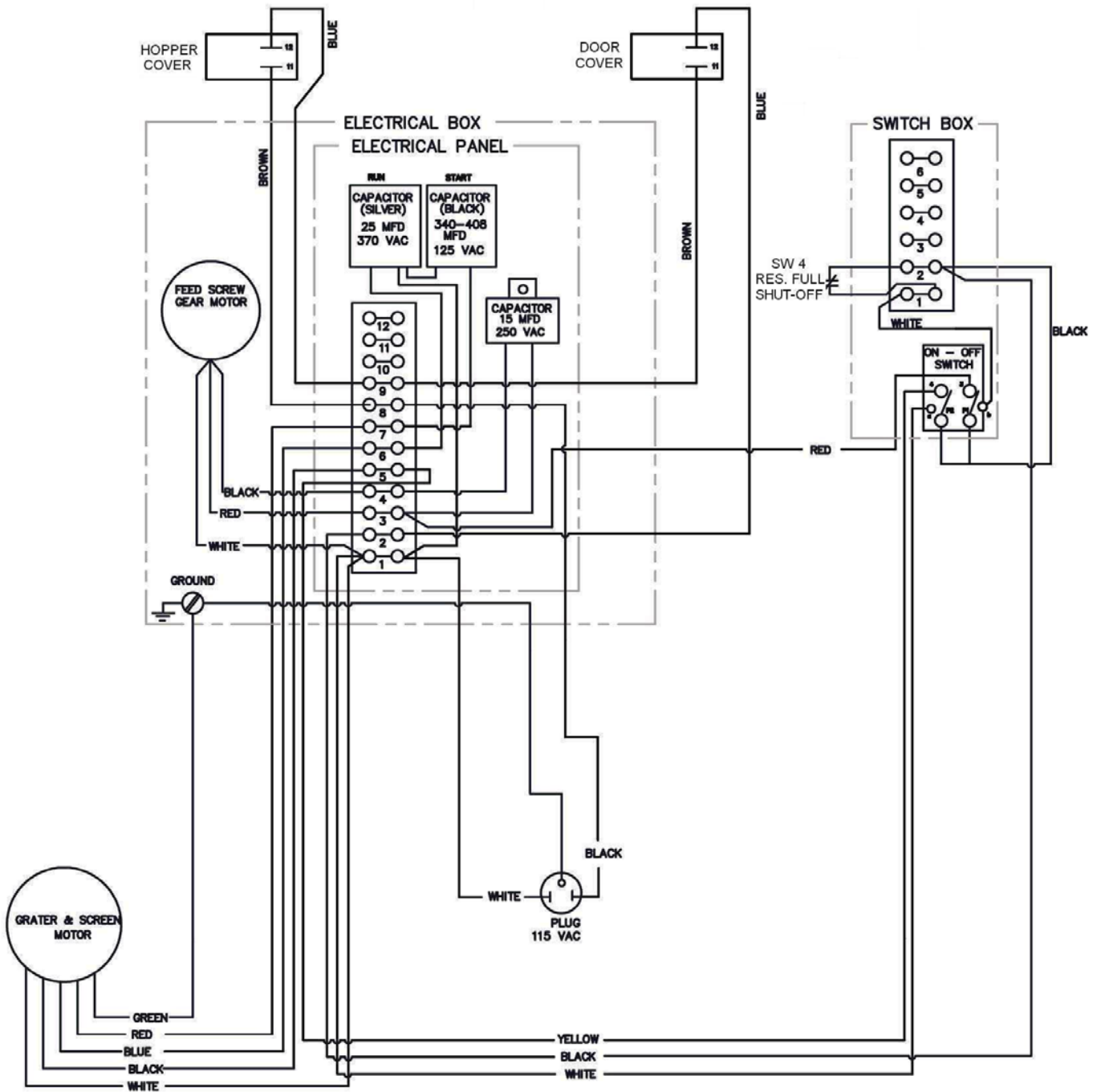

110 VOLT MACHINES

Enclosure, Start Switch Assembly 060-05060C

Item	Qty	Part Number	Description
1	1	060-05059-C	Enclosure, Electrical
2	1	006-060-078	Strain Relief Fitting
3	1	006-060-077	Strain Relief Fitting
4	1	006-221-079	Terminal Block, Phoenix #G 5/6
5	1	006-200-474	Switch, On/Off, Weber #AHWTHD15Z4
6	1	009-235-073	Switch Gasket
7	2	004-440-001	Screw, Type "F", #4-40 x 3/4" Lg, S.S.
8	2	004-440-011	Screw, Type "F", #6-32 x 1/2" Lg, S.S.
9	2	060-05064-B	Spacer, Terminal Block
10	1	007-486-118	Sealing Ring, Hubbell #205-09-001
11	1	007-146-010	Nut, Tru-Seal, 1/2 NPT
12	1	060-00096-03	Wire, White, 20 GA x 5"
13	1	006-221-084	1/8 Spade Female 20 GA
14	A/R	009-455-002	Marker Pins, Phoenix #BNB:1-6
15	2	004-440-010	Screw, Type "F", #4-40 x 3/8" Lg, S.S.
16	1	006-221-082	1/4 Spade Term 16 GA
17	1	006-221-083	1/4 Spade Term 12 GA
18	1	006-260-068	Wire, Black, 16 GA x 10" Lg

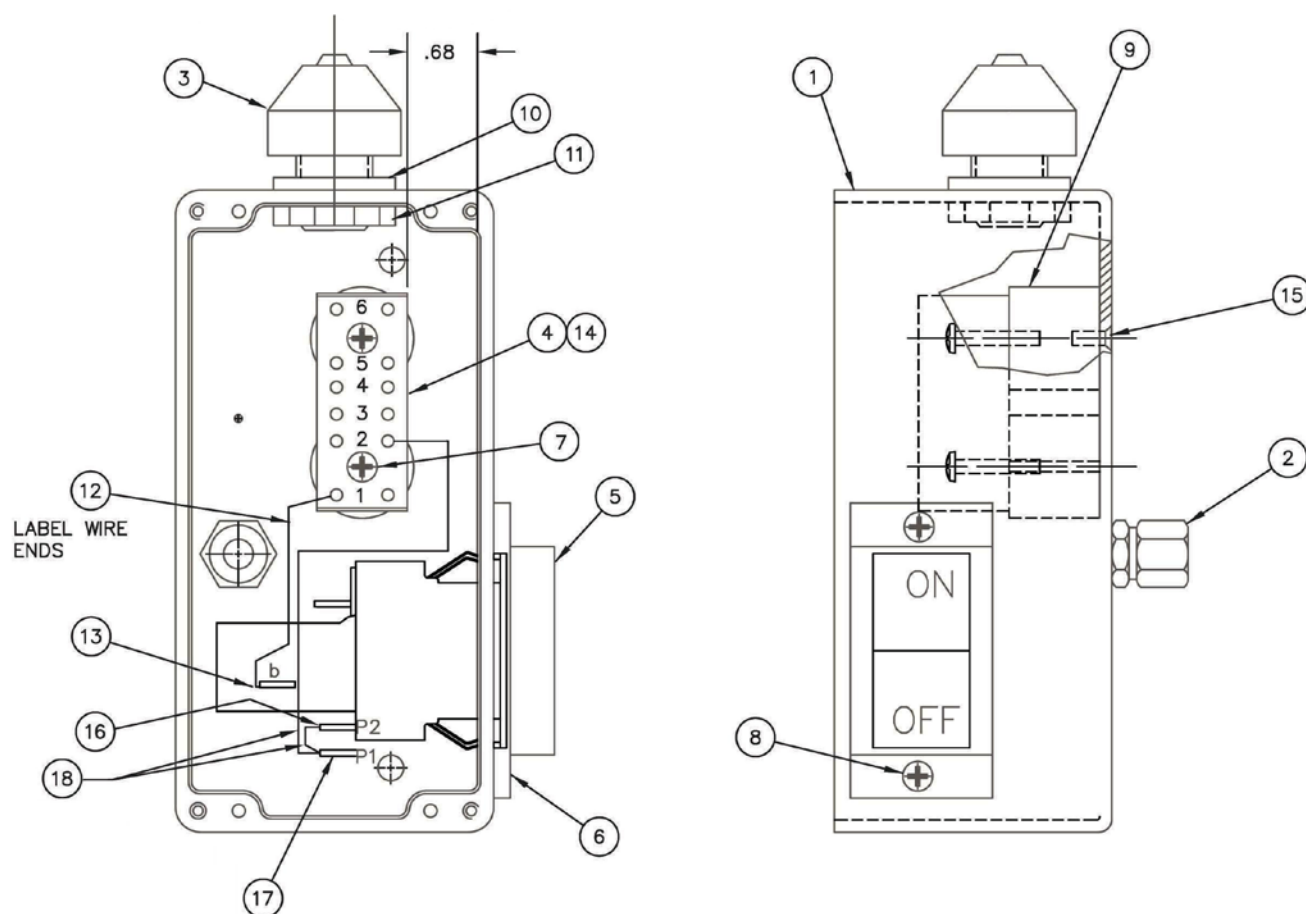



Electrical & Gearbox Sub-Assembly 060-05065-C

Item	Qty	Part Number	Description
1	1	060-05033-F	Electrical Box
2	1	060-05062-C	Panel Assembly, Electrical
3	1	005-617-149	Gearmotor
4	1	060-05032-B	Gear, Stainless Steel
5	1	005-576-223	Key, Sq. 3/16 x 1" Lg, S.S.
6	2	004-541-111	Screw, Set, Self-Locking, 5/16-18 x 3/4" Lg, S.S.
7	1	060-05070-B	Drain Vent
8	1	006-270-194	Connector, Cord, Hubbell #NHC-1023-CRN
9	2	006-060-077	Connector, Cord, 1/2 NPT x 1/2 Cord, T&B #2673
10	6	004-401-022	Screw, Mach., Truss Head, #10-24 x 3/8" Lg, S.S.
11	3	007-486-118	Sealing Ring
12	3	007-146-010	Nut, Tru-Seal, 1/2 NPT
13	4	004-352-280	Screw, Cap Hex, 1/4-28 x 3/4" Lg, S.S.

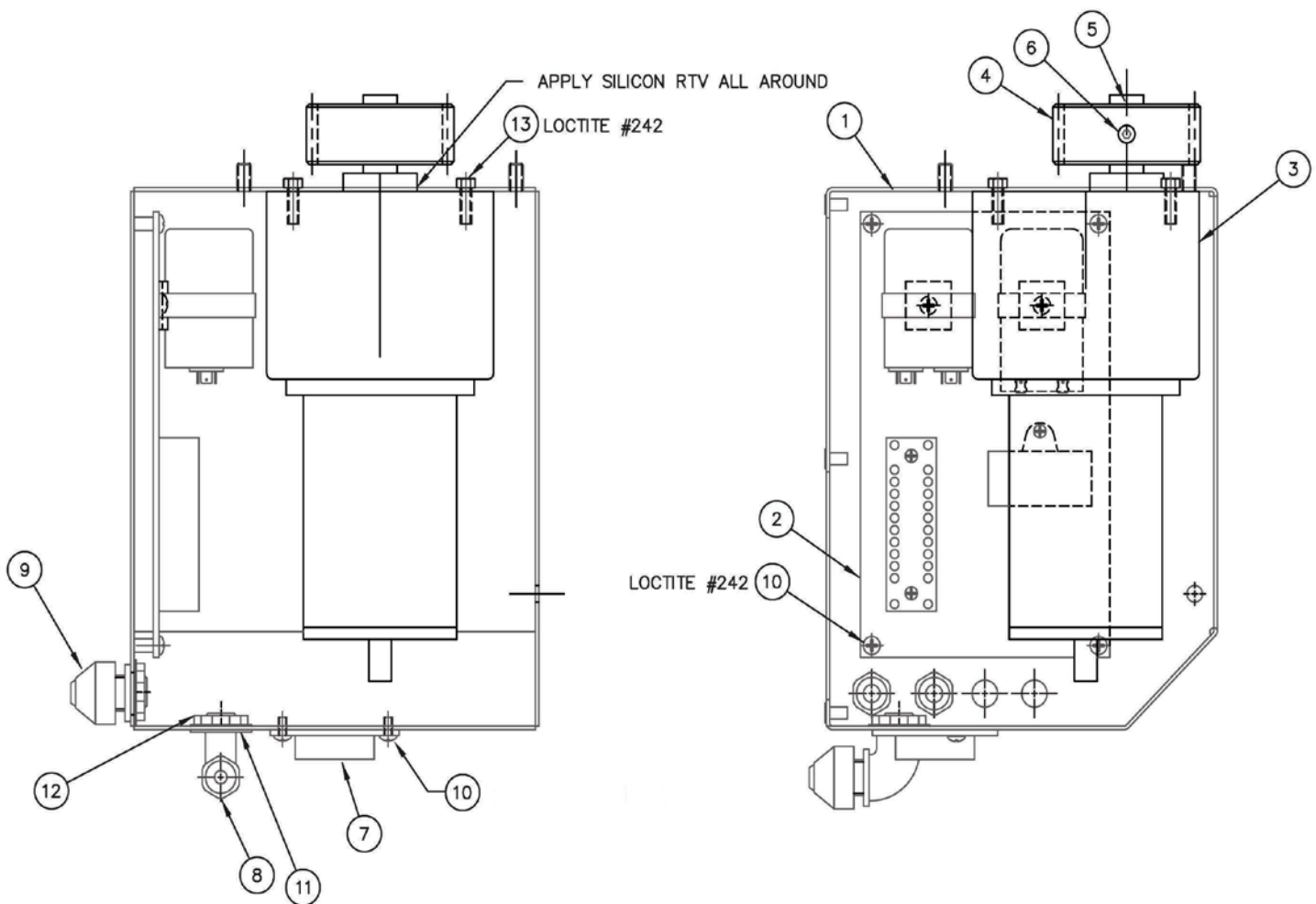

Electrical Panel Assembly

060-05062C

Item	Qty	Part Number	Description
1	1	060-05061-C	Panel, Electrical
2 or 11	1	006-035-023	Capacitor, 340-408 MFD, 110V (Supplied with Motor)
3 or 12	1	006-035-024	Capacitor, 25 MFD, 110V (Supplied with Motor)
4	1	006-035-025	Capacitor, 15 MFD, 60 or 50 Hz (Supplied with Gearmotor)
5	1	006-221-080	Terminal Block, Phoenix #G 5/12
6	2	004-440-001	Screw, Type "F", #4-40 x 3/4" Lg, S.S.
7	2	009-723-039	Clamp, Capicator, Richco #UMS-32-45
8	3	004-397-077	Screw Mach., Round Head, # 8-32 x 1/2" Lg
9	A/R	009-455-003	Marker Pins, Phoenix #BNB:1-12
10	2	006-221-082	1/4 Spade Term 16 GA
11	1	006-035-026	Capacitor, 460-552 MFD, 220V (Supplied with Motor)
12	1	006-035-029	Capacitor, 30 MFD, 220V

Items 2 & 3 are for 110 Volt Motors, Items 11 & 12 are for 220 Volt Motors

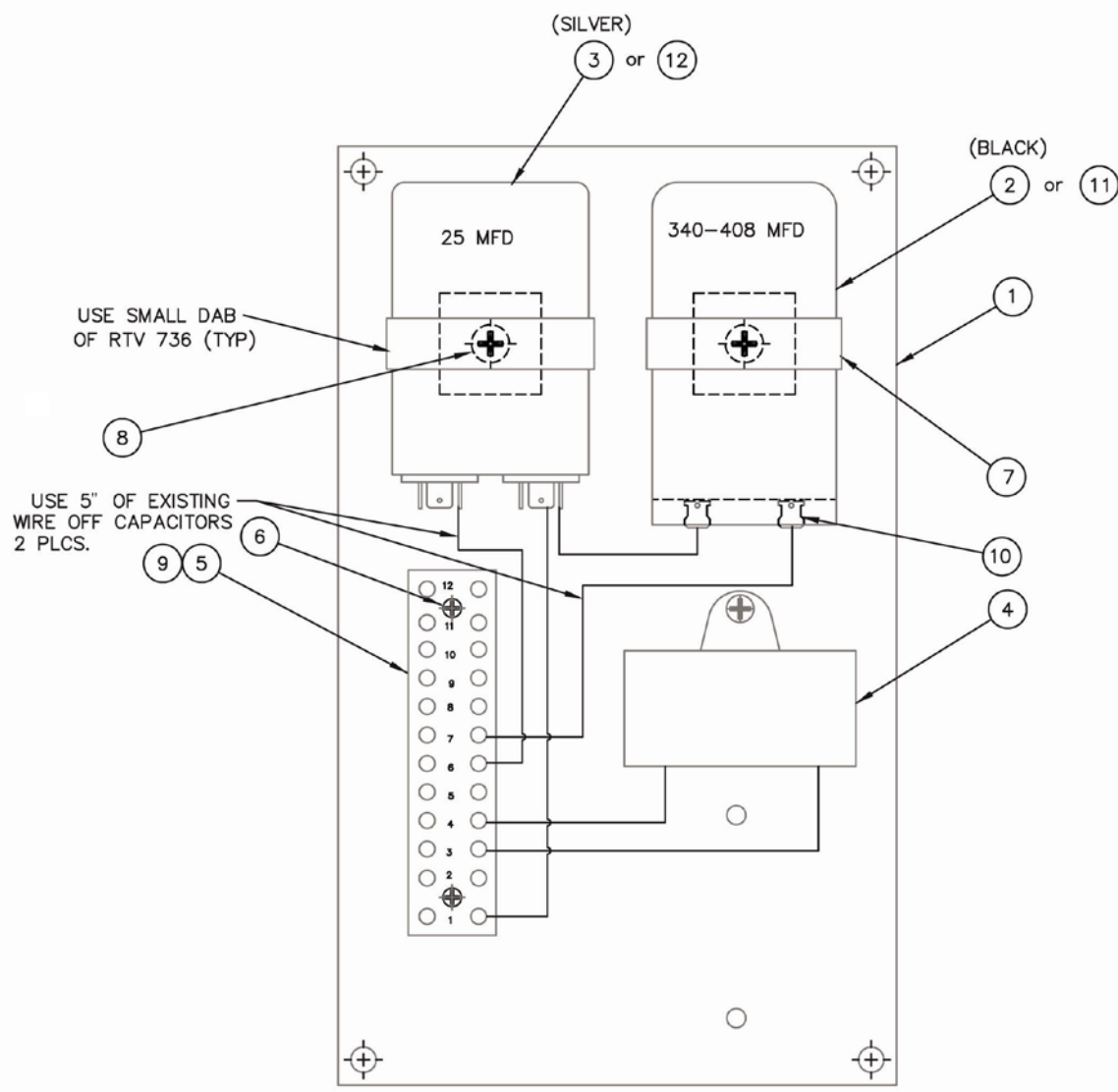



Electrical Diagram & Assembly, 220 Volt 060-05093-D

Item	Qty	Part Number	Description
2	5	009-097-003	Cable Tie
3	2	004-440-011	Screw Type "F", #6-32 x 1/2" Lg, S.S.
4	1	060-05060-C	Enclosure, Start Switch Assembly
5	2	004-401-022	Screw Mach., Truss, #10-24 x 3/8" Lg, Phillips, S.S.
6	1	060-05104-B	Cord, 4 Cond 16 GA
7	1	006-270-141	Cable Mount Small
8	1	060-05065-C	Electrical & Gearbox Sub-Assembly
9	3	006-220-014	Terminal, # 10 Ring End 10-12 GA.
10	4	004-156-063	Nut Hex, 5/16-18 Self-Locking, S.S.
11	1	006-210-290	Proximity Switch (NC)
12	1	006-080-072	Power Cord #14/3 x 10'-0" Lg
13	4	004-111-022	Nut Hex, #10-24, S.S.
14	4	004-816-070	Washer Plain, 5/16, S.S.
15	2	006-221-082	1/4 Spade Term 16 GA
16	1	006-221-084	1/8 Spade-Fem-20 GA
17	1	004-397-129	Screw Mach., Round Head, # 10-24 x 1/4" Lg
18	4	009-654-002	Cable Retainer
19	1	060-05092-C	Enclosure, Transformer
20	1	060-05091-C	Plate, Mounting, Transformer
21	1	006-240-030	Transformer, Signal #M4L-2-10
22	2	006-270-194	Connector, Cord, Hubbell #NHC-1023-CRN
23	2	007-486-118	Sealing Ring
24	2	007-146-010	Nut, Tru-Seal, 1/2 NPT
25	2	060-05070-B	Drain Vent
26	4	004-401-022	Screw, Mach., Truss Head, #10-24 x 3/8" Lg, S.S.
27	4	004-605-007	Stand-Off, Male/Female #10-32 Thread, S.S.
28	4	004-156-043	Nut Hex, #10-32, Self-Locking, S.S.
29	2	004-392-172	Screw, Hex, Socket Head, 1/4-28 x 3/4" Lg, S.S.
30	2	004-816-063	Washer, Plain, 1/4", S.S.
31	3	006-220-004	Terminal, # 10 Ring End 16-14 GA
32	1	004-397-129	Screw, Mach., Round Head, #10-24 x 1/4" Lg, S.S.
33	1	006-080-079	Cord #12/3 x 28" Lg
34	1	Plug	Determined by Machines Destintation
35	1	060-05094-B	Grommet
36	2	006-200-482	Switch, Interlock, Schmersal #AZ15
37	1	007-143-370	Fitting, Strain Relief, 90°
38	1	007-143-395	Fitting, Strain Relief, Straight
39	1	006-080-073	Cord, 14/2 x 42"
40	1	006-080-073	Cord, 14/2 x 27"
41	2	004-401-026	Screw, Mach., Truss Head, #10-24 x 5/8" Lg, S.S.
42	4	004-816-052	Washer, Plain, #10
43	1	004-401-032	Screw, Mach., Truss Head, #10-24 x 1" Lg, S.S.
44	1	007-143-474	Fitting, Strain Relief, 90°
45	1	007-143-396	Fitting, Straight Strain Relief

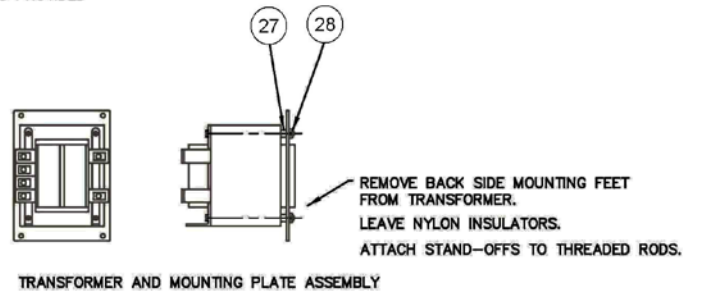
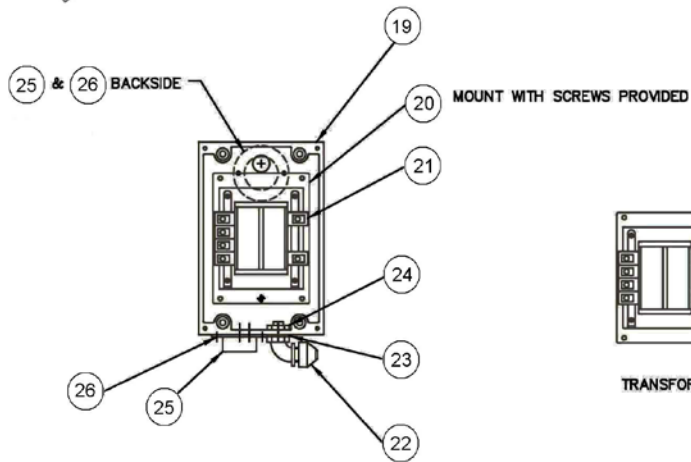
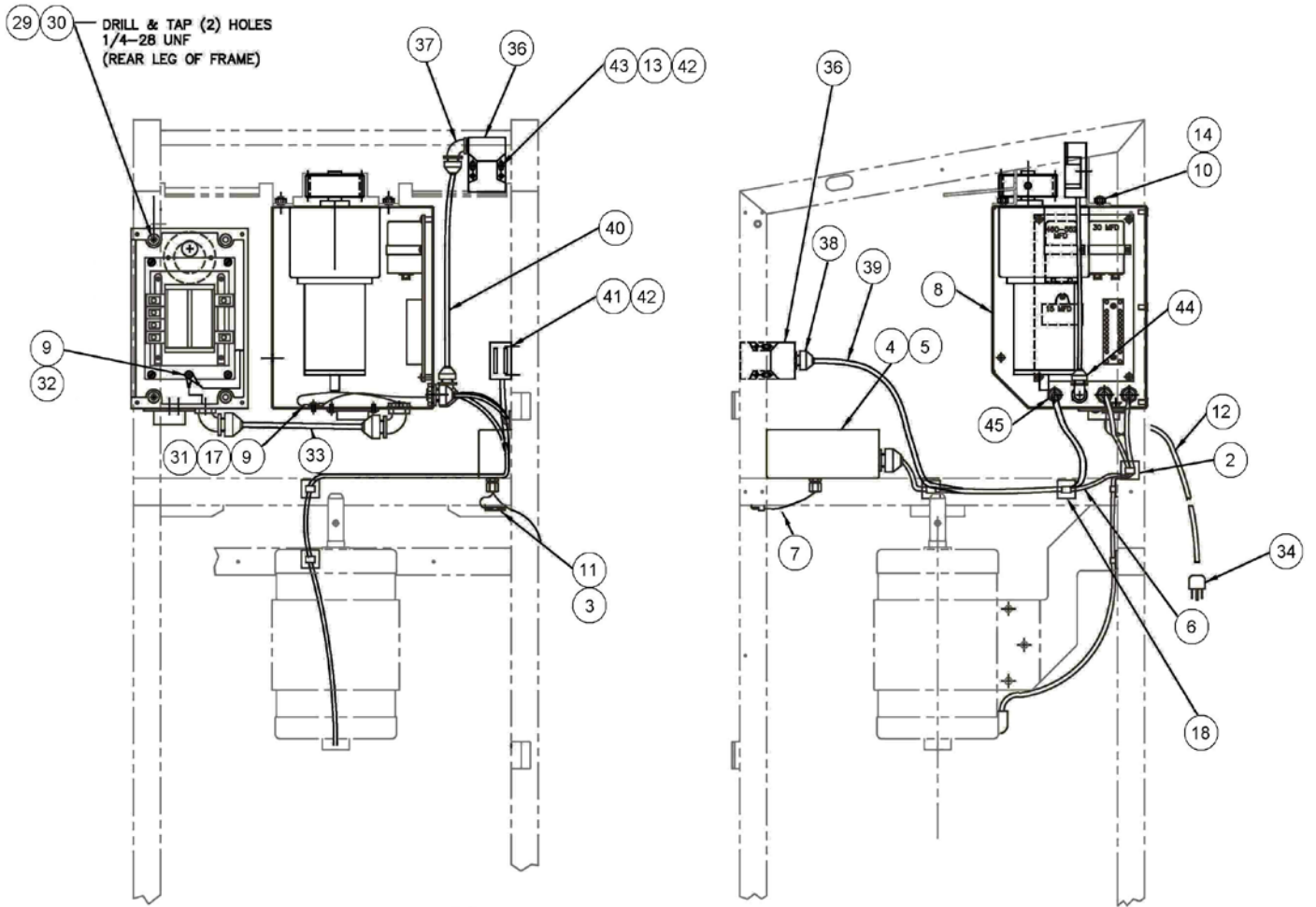

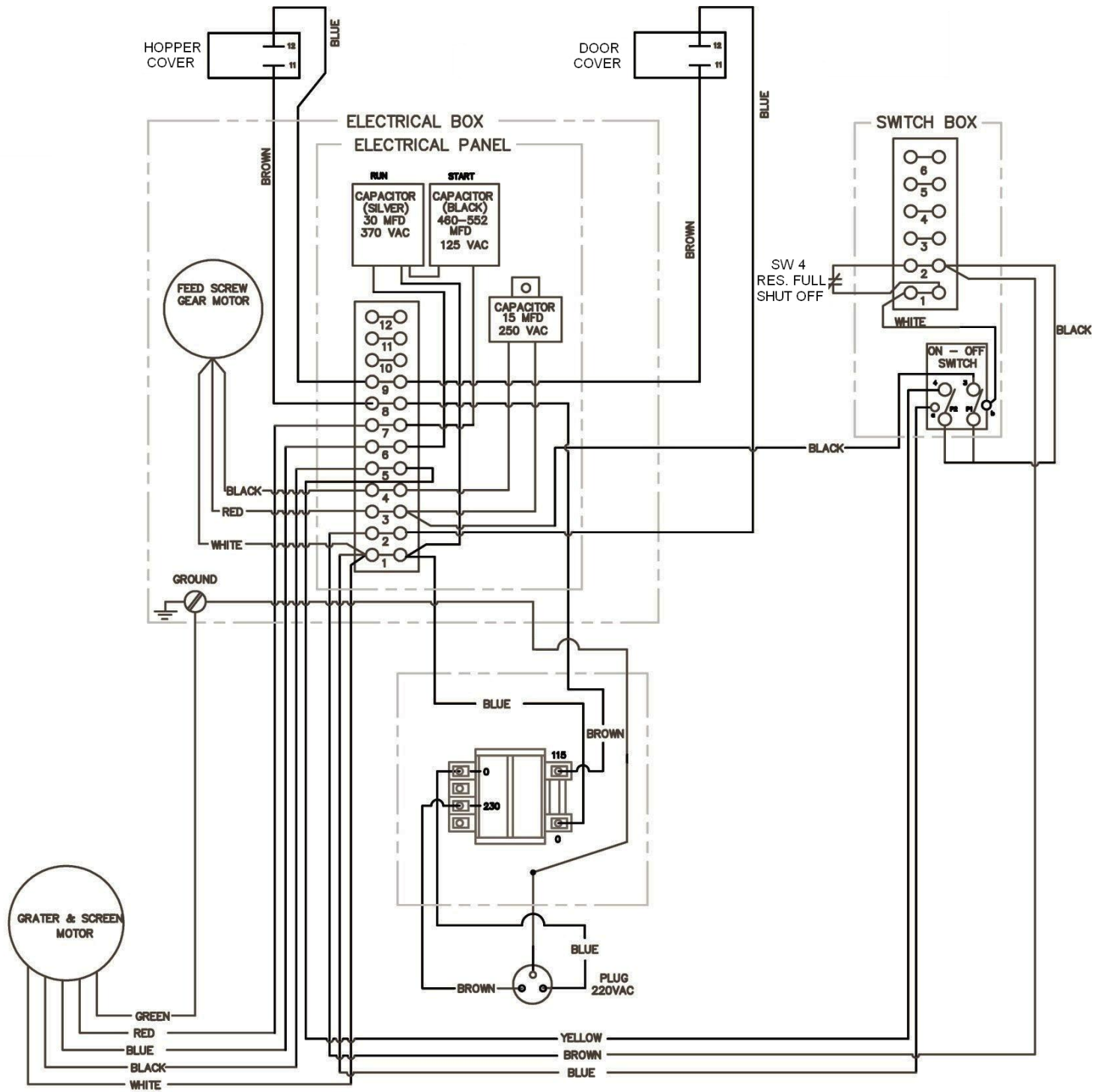

220 VOLT MACHINE