



Leveraging Enterprise Data to Optimize Business Results – From Intelligent Reporting to Predictive Analysis

Steve Mink

IM Mainframe Software

mink@us.ibm.com



Information Management Portfolio

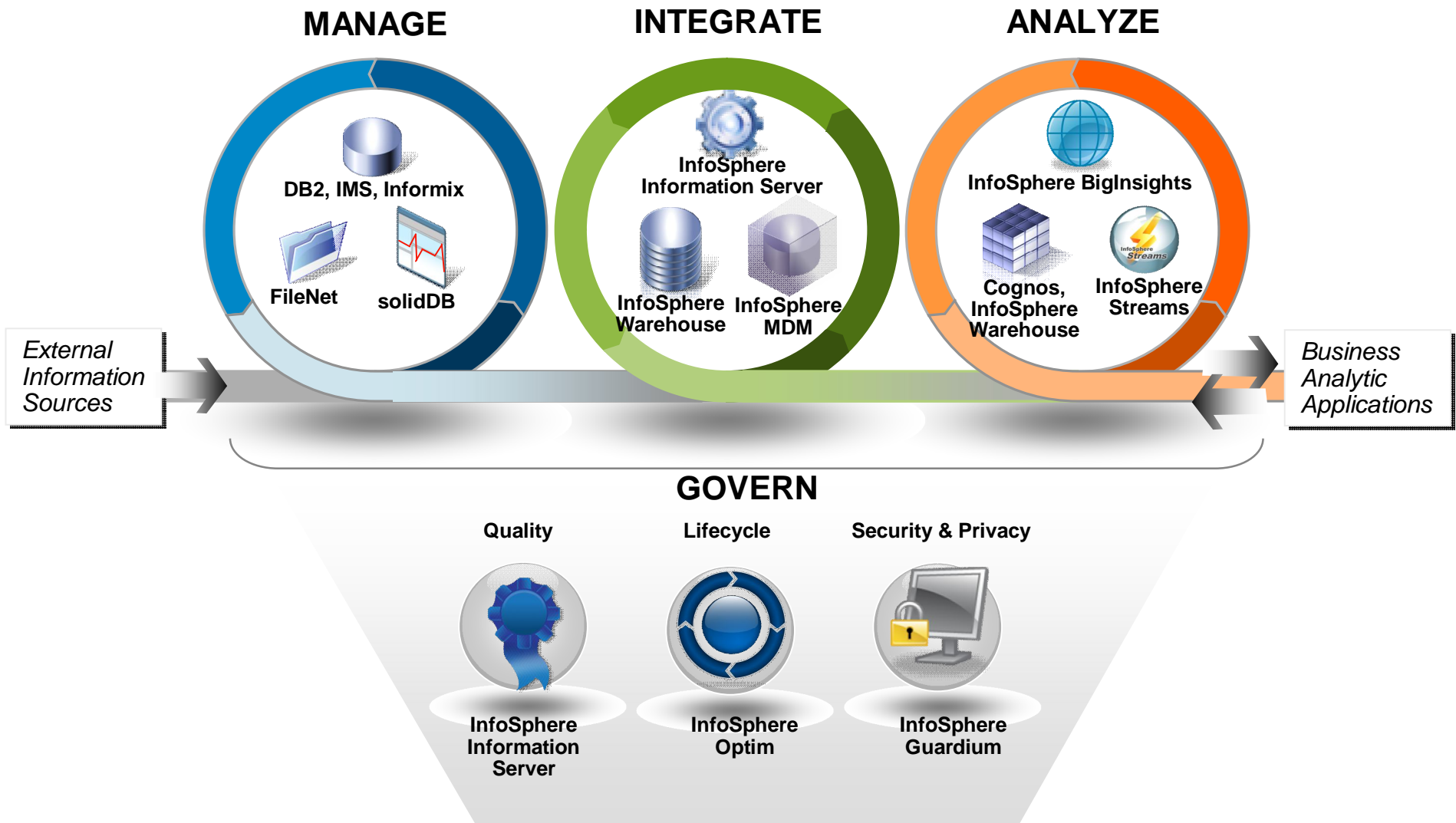

Information Management for System z

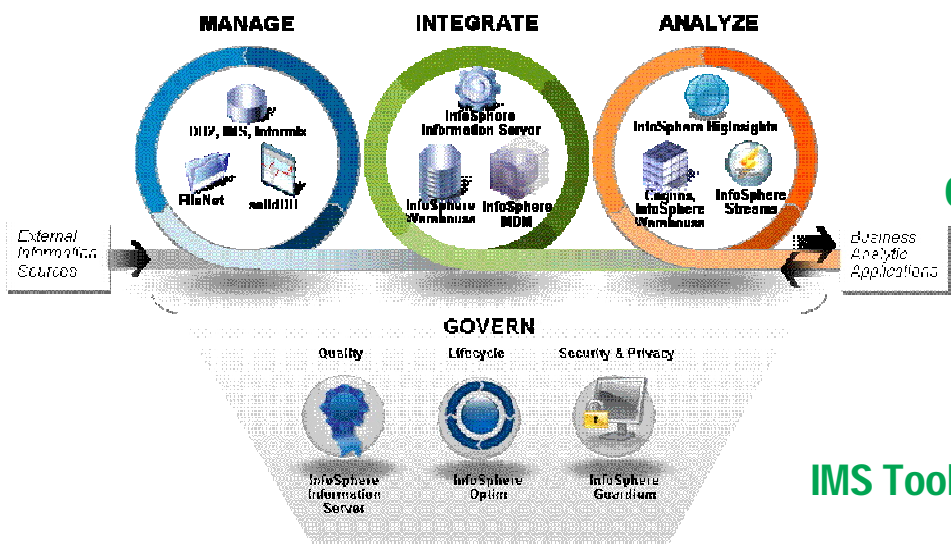

InfoSphere Discovery for z/OS
 InfoSphere Warehouse for System z
 Cognos 8 BI for System z
 InfoSphere MDM Server for System z
 Optim Data Governance for System z
 Information Server for System z

IMS 12
 Netezza for System z
 Active Active for z/OS
 Industry Models for System z
 Cognos 8 BI for z/OS
 Smart Analytics Optimizer for z/OS
 OMEGAMON DB2 end-to-end monitoring
 DB2 10 for z/OS
 DB2 Sort for z/OS
 Guardium for System z
 SPSS for System z
 ISAS 9600 for System z
 IMS Tools Solution Packs for z/OS
 IMS 11 for z/OS

2011

2010

2009

2008

Analytics

Information-Led Transformation

Business Intelligence

Information Agenda

Information On Demand

Data Warehousing

Investing in Innovation

*Over 50 Billion Transactions
Per Day run through IMS*

IMS 11



Direct distributed access to IMS Data

- Reduces processing costs up to 67%

Easier Application Programming

- IMS DL/I knowledge not needed
- Java SQL support

*Generally Available
October 30, 2009*

Easier than Ever



On-line DB Reorganization

- 25% CPU Time Reduction

New Enterprise Suite

- Repackaging of IMS middleware
- Easier to order and install

IMS 11 Quality Partnership Program Results

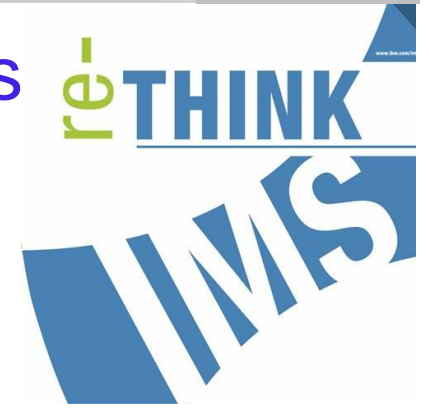

- **12 Customers, 2 IBM internal sites, 30 vendors**
 - 6 customers running mission critical production prior to GA each running up to 80M transactions per day
 - 4 customers have entire enterprise in production on V11 prior to GA
 - 2 customers migrated with 100% availability using SHQ
 - Customer satisfaction scores higher than V10

IMS 11...GA October 30, 2009 and already running over

200 Million Transactions per Day



Announcing IMS 12!

- We are excited to announce the start of the IMS 12 Quality Partnership Program
- IMS 12 will offer:

Reduced Costs!

- Up to **10%** out of the box MIPS savings
- Up to **30%** savings on network support

Improved Productivity!

- Up to **50%** faster deployment of IMS resource definitions and changes using the **IMS Explorer**
- Ability to create PLI code from WDSL for rapid application development

Improved Performance!

Database logging up to **2x** faster

Growth Enablement!

Additional storage constraint relief and dynamic change capabilities





Business Challenge

❖ Scotiabank had several objectives focused on enterprise modernization: eliminate costs associated with IBM Communication Servers and SNA LUs; significantly reduce proprietary transaction chaining; improve business function response times and transaction performance; and position IMS applications as first-class players in enterprise SOA solutions.

Solutions

- ❖ IMS Connect and IMS commit processing (CM1)
- ❖ WebSphere Java applications access IMS using the IMS TM Resource Adapter
- ❖ IMS TM Resource Adapter implements sophisticated connection pooling for support of persistent socket connections
- ❖ IMS Connect and TM Resource Adapter support SSL, allowing for Client and Server-side certificate-based SSL connections.
- ❖ Execute various operational scenarios including planned and unplanned “downs” for the network, IMS, IMS Connect, and IMS dependent regions

"We are extremely pleased with the results regarding installation, configuration, tuning, new processes, operations management, and security management." Craig Oddy, Operations, Scotiabank

Benefits

- ❖ MIPS utilization, response times, switchover/failover and recovery, and mid-tier metrics all tested to expectations.

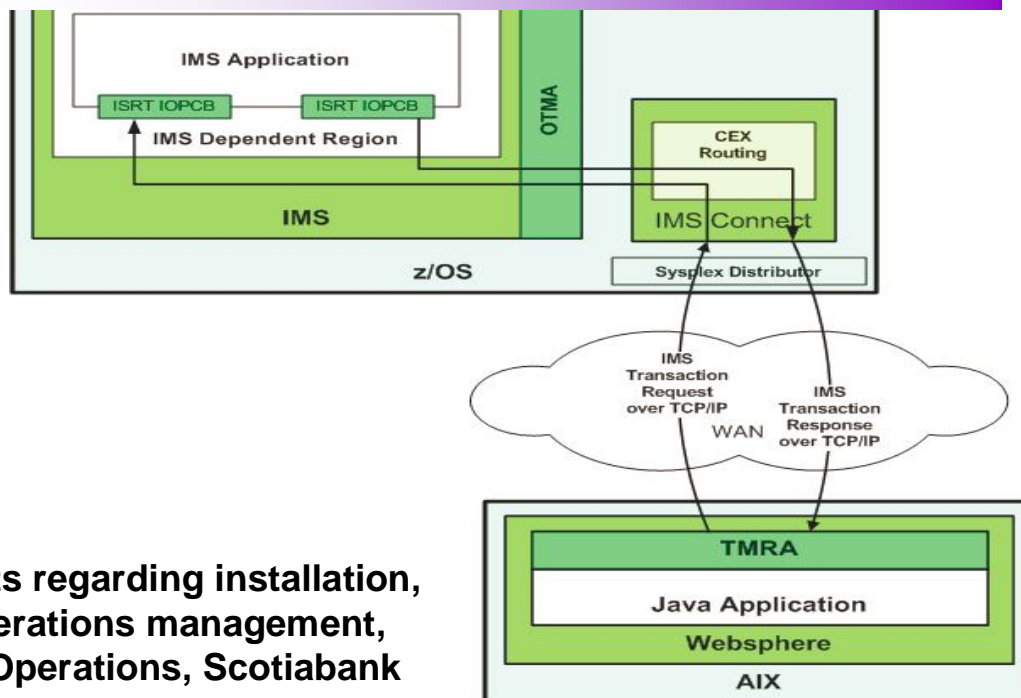



Business Challenge

- ❖ *Transition Green Screen conversational applications to Web based GUI Screen applications*
- ❖ *SOA Enable a Ford IMS MFS Conversational Transaction*
- ❖ *Manage and Monitor the performance and capacity needs*

Solution

- ❖ *Ford's IMS Applications are Conversational and are dependent upon the statefull data resident in the IMS Scratch Pad Area (SPA). IBM is working on a method to maintain the SPA data when executing long running business processes from within WebSphere Process Server*

Benefits

- ❖ *Reuse existing business processes and data*
- ❖ *Modernize the User Interface of CORE Applications without re-writing code*
- ❖ *Reduce Cost for Application Development and Delivery efforts*



Nationwide®

Business Challenges

- ❖ *Provide high availability of existing insurance data across a wide customer base*
- ❖ *Manage high volume of internal and external customer transactions*
- ❖ *Ensure standing in competitive marketplace*

Solutions

- ❖ *Use IMS TM to achieve high performance transaction throughput at lowest cost*
- ❖ *Use IMS Block Level Data Sharing to meet high availability requirements and growth demands*
- ❖ *Investigate use of IMS Shared Queues for effective workload balancing*

Benefits

- ❖ *Efficient, high performance processing of business transactions*
- ❖ *High availability of insurance data*
- ❖ *Scalable environment to handle business growth*



Business Challenge

❖ *Connect IMS applications with distributed applications tracking manufacturing materials across the enterprise, to maintain the currency of data in both systems.*

Solutions

- ❖ *Implement the IMS SOAP Gateway on z/OS.*
- ❖ *Implement both asynchronous and synchronous Callout from IMS programs.*
- ❖ *Implement IMS V11 With ODBM*

- *"IMS "Callout", ODBM, and the SOAP Gateway allow us to keep data in distributed systems in "sync" with that in the legacy IMS systems, helping maintain inventory control."*

*Steve Clanton
IT Transactional Services, Caterpillar Inc.*

Benefits

❖ *Data for tracking materials is updated between systems allowing better control of inventory and eliminating waste.*



Handelsbanken

Business Challenge

❖ *For Handelsbanken customer satisfaction is a priority . Handelsbanken needed a reliable and secure back-end systems to support their global 24x7 online banking business. In addition, the bank was determined to achieve milliseconds execution time for their ATM and POS transactions.*

Solutions

- ❖ *Run ATM and POS as Fast Path transaction thru IMS Connect*
- ❖ *Leverage Geographically Dispersed Parallel Sysplex (GDPS) for data integrity*
- ❖ *Achieve high availability by using IMS and DB2 datasharing in a Parallel Sysplex environment.*
- ❖ *Install WAS, MQ and DB2 within the same partition as IMS for scalability and security*

Benefits

- ❖ *Global, 24x7 customer satisfaction for Handelsbanken e-banking services and instant response time for all ATM and POS transactions*

“By reusing our IMS applications, we are able to sustain a high return on our IMS investment”
 Curt Bergkvist, IMS Technical Specialist,
 Handelsbanken

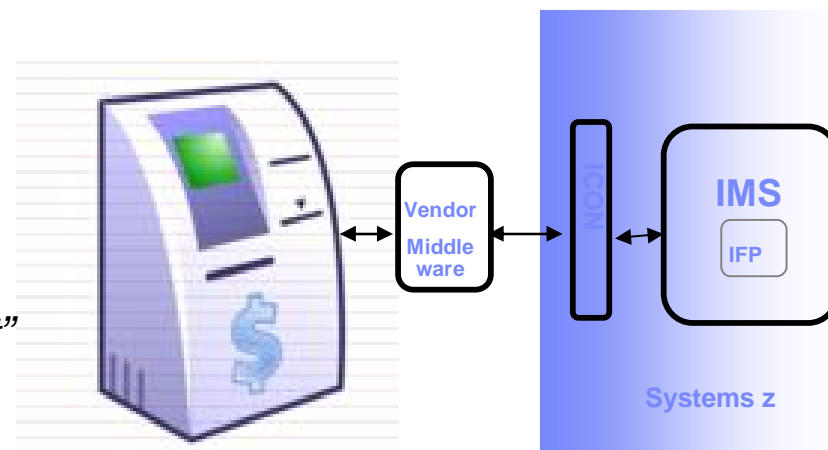



Business Challenge

- *Redundant transaction manager infrastructure for core banking applications as result of BBK and CajaSur bank merger*
- *Potential system bottleneck due to a single gateway to backend core IMS system for multichannel applications*

Solutions

- *Consolidate different Transaction Manager Systems into IMS systems*
- *Enhance IMS connectivity to handle additional workload by installing another IMS Connect instance and exploiting IMS Connect super member support*

Benefits

- *Expected cost reduction due to single and consistent IMS infrastructure for core banking applications across the enterprise*
- *Improved availability for multichannel applications via enhanced connectivity*
- *Workload isolation for ATMs, POS, online banking and branch offices applications*

IMS Regional User Groups World-wide

Free technical education; network with other IMS customers

Americas

Boston, MA
 Chicago, IL
 Cincinnati, OH
 Columbus, OH
 Costa Mesa, CA
 Dallas, TX
 Detroit, MI
 Glendale, CA
 Hartford, CT
 Jacksonville, FL
 Minneapolis, MN
 NY, NY
 Omaha, NE
 Philadelphia, PA
 Phoenix, AZ
 San Ramon, CA
 Sao Paulo, Brazil
 Seattle, WA
 Springfield, IL
 Tampa, FL
 Toronto, Canada
 Washington, DC
 Vancouver, Canada
 Victoria, BC



EMEA& AP

Amsterdam
 Brussels
 Copenhagen
 Chennai
 Dusseldorf
 Helsinki
 Johannesburg
 Madrid
 Melbourne
 Munich
 Oslo
 Stockholm
 Stuttgart
 Sydney
 Taipei

DB2 for z/OS Technical Strategy

- Extend the lead in availability, scalability and performance.
 - Parallel Sysplex: the best scale-out solution in the industry
 - Tight integration between DB2 and the System z hardware and z/OS operating system
 - Advanced solutions for compliance with data security and privacy regulations
 - Workload consolidation: System z is the ultimate consolidation platform
 - Eliminate all causes of outages
- Reduce cost of ownership
 - Database technology that can handle large workloads with fewer people
 - Storage and CPU optimization, including specialty engines
 - Advanced autonomies to make the system more self-managing and self-tuning
- Application enablement
 - Apps can easily connect to DB2 from anywhere
 - Advanced SQL, XML capability, application portability
- Improved data warehousing capabilities

DB2 10 for z/OS At a Glance

Application Enablement	<ul style="list-style-type: none"> • pureXML enhancements • Temporal queries • Last Committed reads • Timestamp with timezone • SQL improvements that simplify porting
RAS, Performance, Scalability, Security	<ul style="list-style-type: none"> • Wide range of performance improvements • More online schema changes • Catalog restructure for improved concurrency • Fine grained access control • Hash access to data • New DBA privileges with finer granularity
Simplification, Reduced TCO	<ul style="list-style-type: none"> • Full 64-bit SQL runtime • Auto stats • Data compression on the fly • Query stability and management enhancements • Reduced need for REORG • Utilities enhancements
Data Warehousing	<ul style="list-style-type: none"> • Moving sum, moving average • Many query optimization improvements • Query parallelism improvements • Advanced query acceleration

DB2 10 for z/OS: Out-of-the-Box Savings

Up to 20% CPU reductions for transactions, queries, and batch

- Out-of-the-box CPU reductions of 5-10% for traditional workloads
- Out-of-the box CPU reductions of up to 20% for new workloads
- Up to additional 10% CPU savings using new functions

Scales with less complexity and cost

- 5-10x more concurrent users – up to 20,000 per subsystem
- Significant scale-up capabilities in addition to existing scale-out support
- Consolidate to fewer LPARs and subsystems

Improved operational efficiencies and lower administration cost

- Automatic diagnostics, tuning, and compression

Even better performance

- Elapsed time improvement for small LOBS and Complex Queries



Running a Large Number of Threads

Today

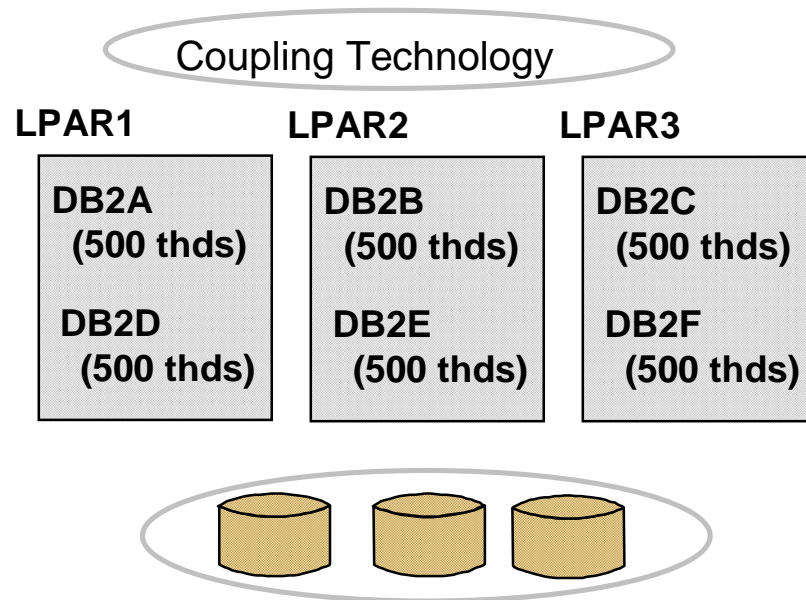

- Data sharing and sysplex allows for efficient scale-out of DB2 images
- Sometimes multiple DB2s / LPAR

DB2 10

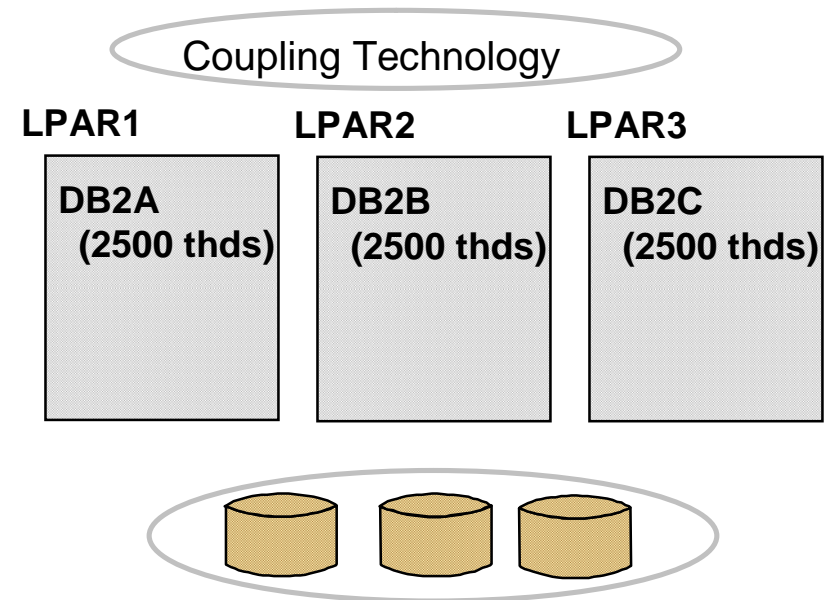

- More threads per DB2 image
- Potential for fewer members / LPARs
- More efficient use of large n-ways
- SSI constraints are relieved
- Easier growth, lower costs, easier management
- Data sharing required for continuous availability and XL scale

Temporal Data – Need to Query ‘AS OF’

Temporal Query & Business Timestamp

- **Table-level specification to control data management based upon time**
- **Two notions of time:**
 - **System time:** notes the occurrence of a data base change
 - “row xyz was deleted at 10:05 pm”
 - Query at current or any prior period of time
 - Useful for auditing and compliance
 - **Business time:** notes the occurrence of a business event
 - “customer xyz’s service contract was modified on March 23”
 - Query at current or any prior/future period of time
 - Useful for tracking of business events over time, application logic greatly simplified
- **New syntax in FROM clause to specify a time criteria for selecting historical data**



DB2 10 for z/OS: Savings and performance

- Up to 40% savings in processing costs
- Up to 6 times the number of SAP users on a single system
- Time Travel temporal capabilities built directly into the database
- Direct Row access accelerates high performance applications



"We have measured a 38% reduction in CPU for heavy insert workloads in a data sharing environment. That's a significant savings which provides immediate business benefit."

Peter Paetsch, BMW Group

We expect to reduce our data sharing requirements by 25%, which means less system, storage and resource expenses

Banco do Brasil



Major Insurance Company

The new temporal functionality in DB2 10 for z/OS will allow us to drastically simplify our data-related queries and reduce our processing cost by having DB2 handle data movement more efficiently than our custom code

"As much as 80% of our applications can use this, which will drastically save developer time and even more importantly make applications easier to understand to improve business efficiency and effectiveness"



"In addition to the cost savings, DB2 10 for z/OS offers a far superior data server environment than Oracle"



As a multi-national corporation, we must adhere to strict local audit requirements. The security and administration capabilities in DB2 10 are a key driver for us to move to this version."





Jump into DB2 10! The water's fine.



DB2 V8

DB2 9

DB2 10

Key Questions are WHEN? and HOW?

Managing Your Business Environment

IBM's Tools for DB2 and IMS

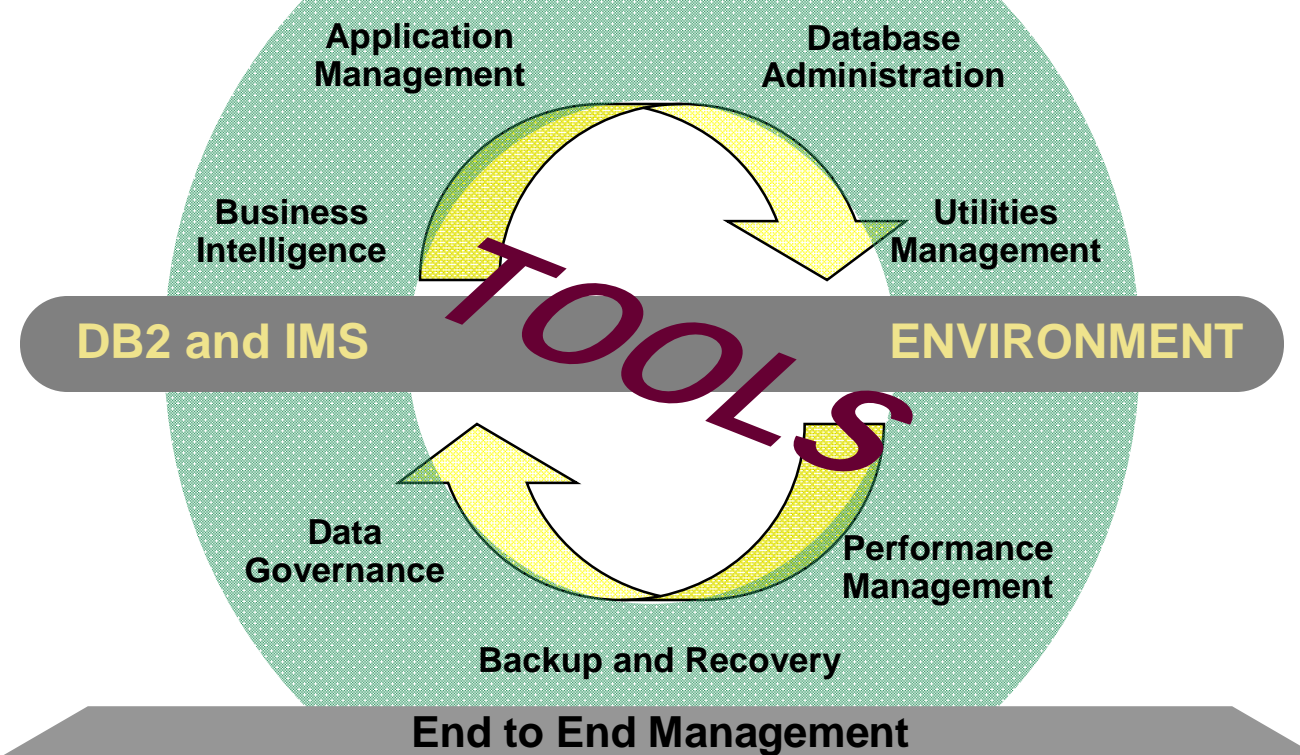
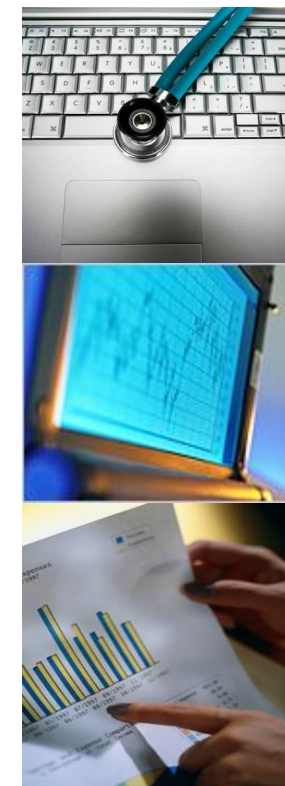

Business Challenges

- Optimizing costs associated with maintaining existing applications
- Quickly responding to new business requirements and opportunities
- Ensuring that business and regulatory needs can be properly met
- Maximizing IT staff productivity to streamline business operations

ROI

Resiliency



IMS Database Solution Pack helps daily DBA tasks

- DB Solution Pack provides a complete set of high performance tools to unload, load, reorganize, build indexes for, backup, verify, and report on full-function databases

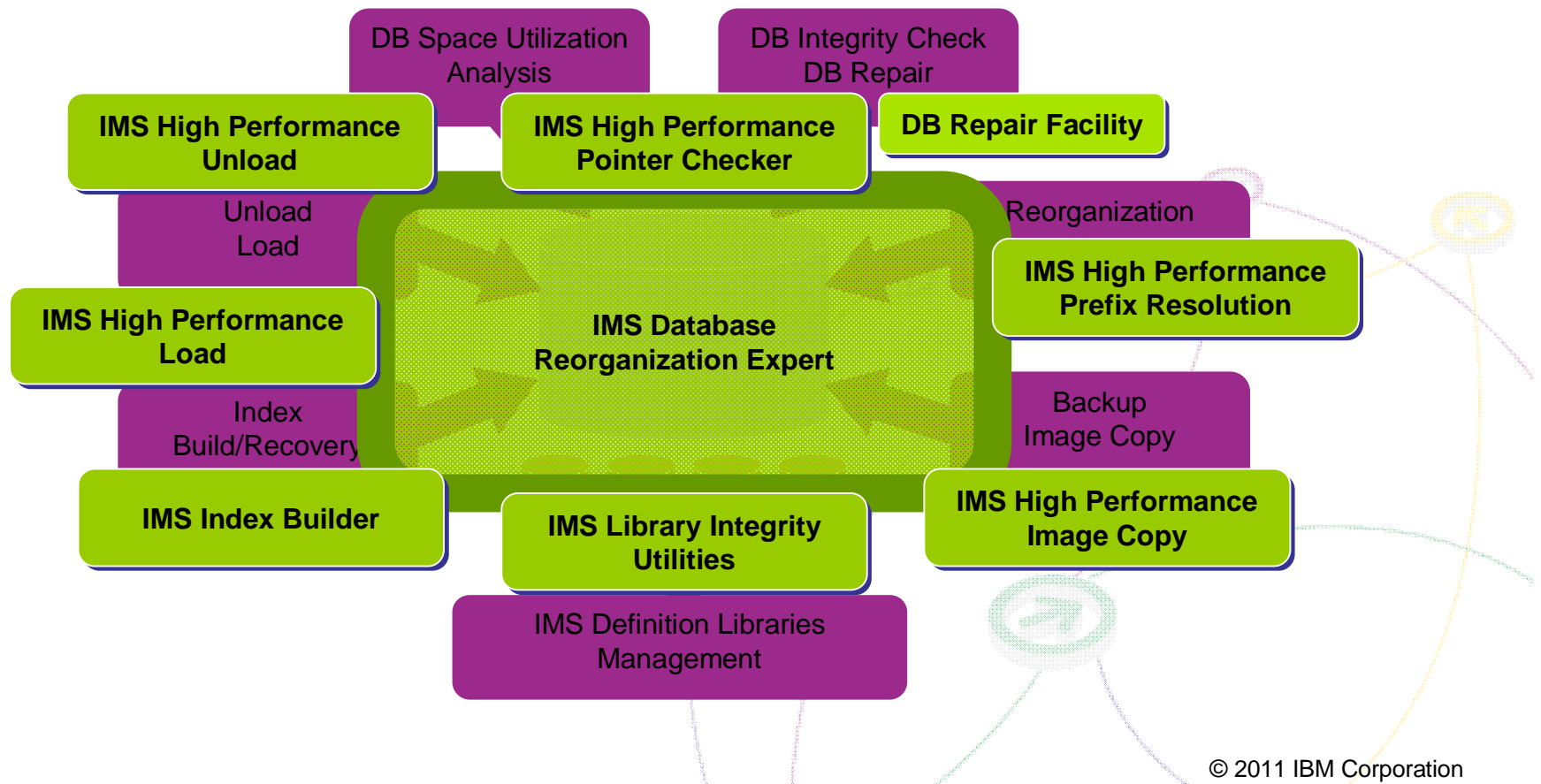



A comprehensive solution for your Backup and Recovery needs

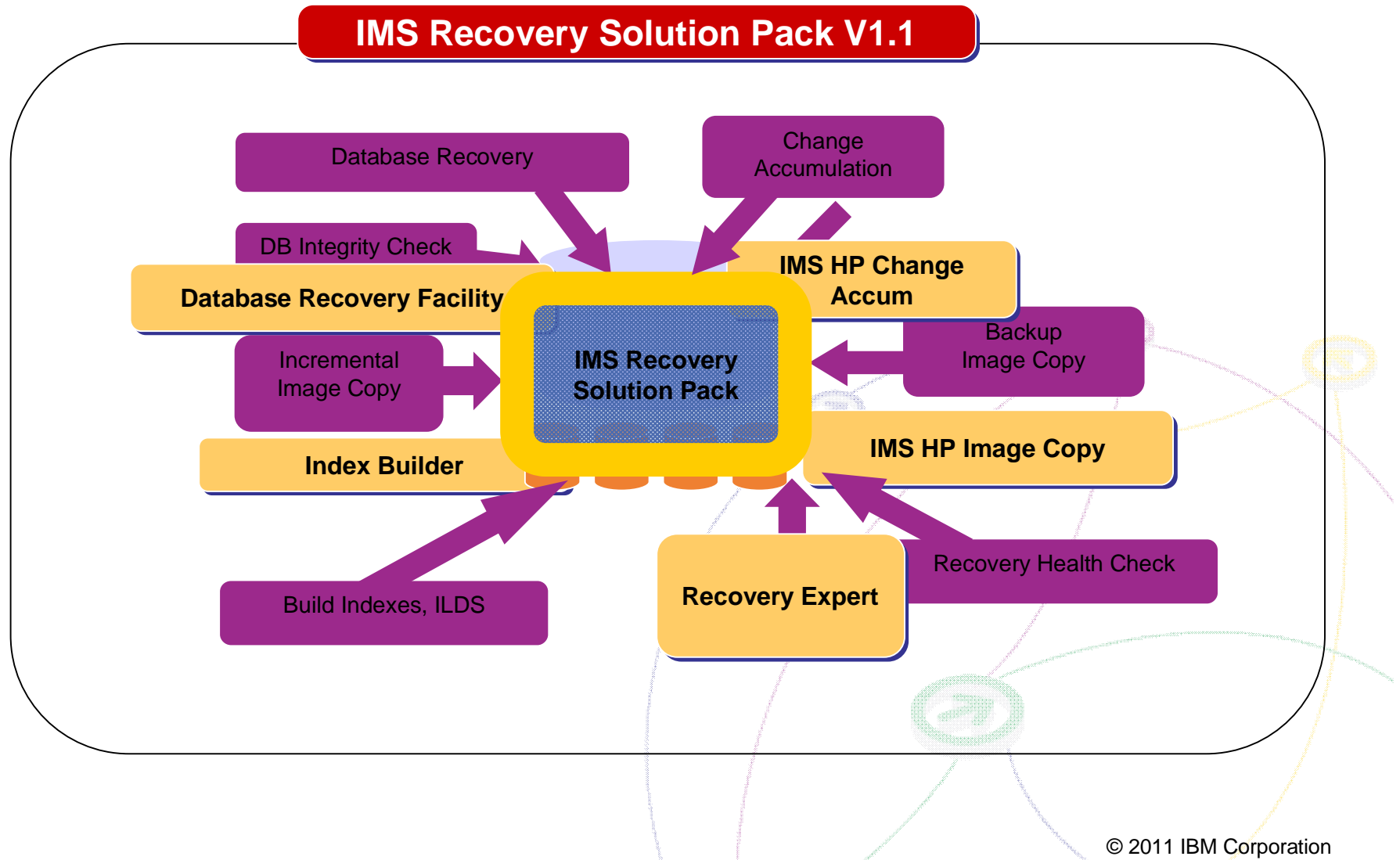



A solution for IMS Performance Management

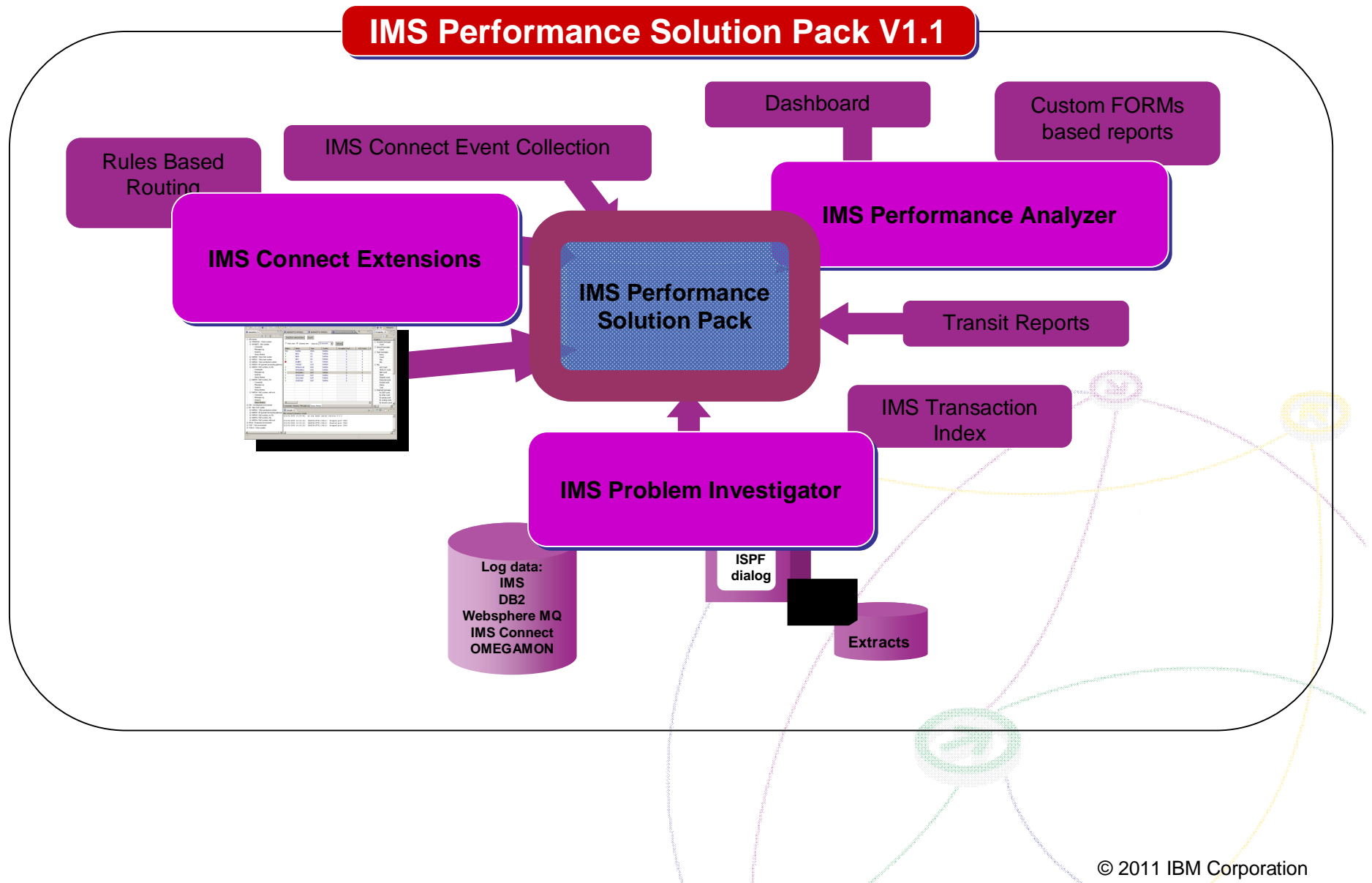

Fast Path Solution Pack helps daily DBA tasks

- **Provides a complete set of high performance utilities for Fast Path databases**
 - Unload, reload, reorganize, backup, verify and report on DEDB areas and tune-up the libraries
- **Saves time and money - reduces resources (CPU and elapsed time)**
 - Parallel processing of DEDB multiple areas in a single step
 - Eliminates I/O for intermediate data sets by enabling multiple utilities tasks to run in a single step
 - Reduces the unavailability time of taking data base image copy using advanced technology
- **Provides online features for improved system availability**
 - Reorganize, extract, extend, backup, verify and report on “online” DEDB areas
- **Completes the Fast Path solution with other valuable utilities:**
 - Image Copy
 - Library Management
 - DB Repair

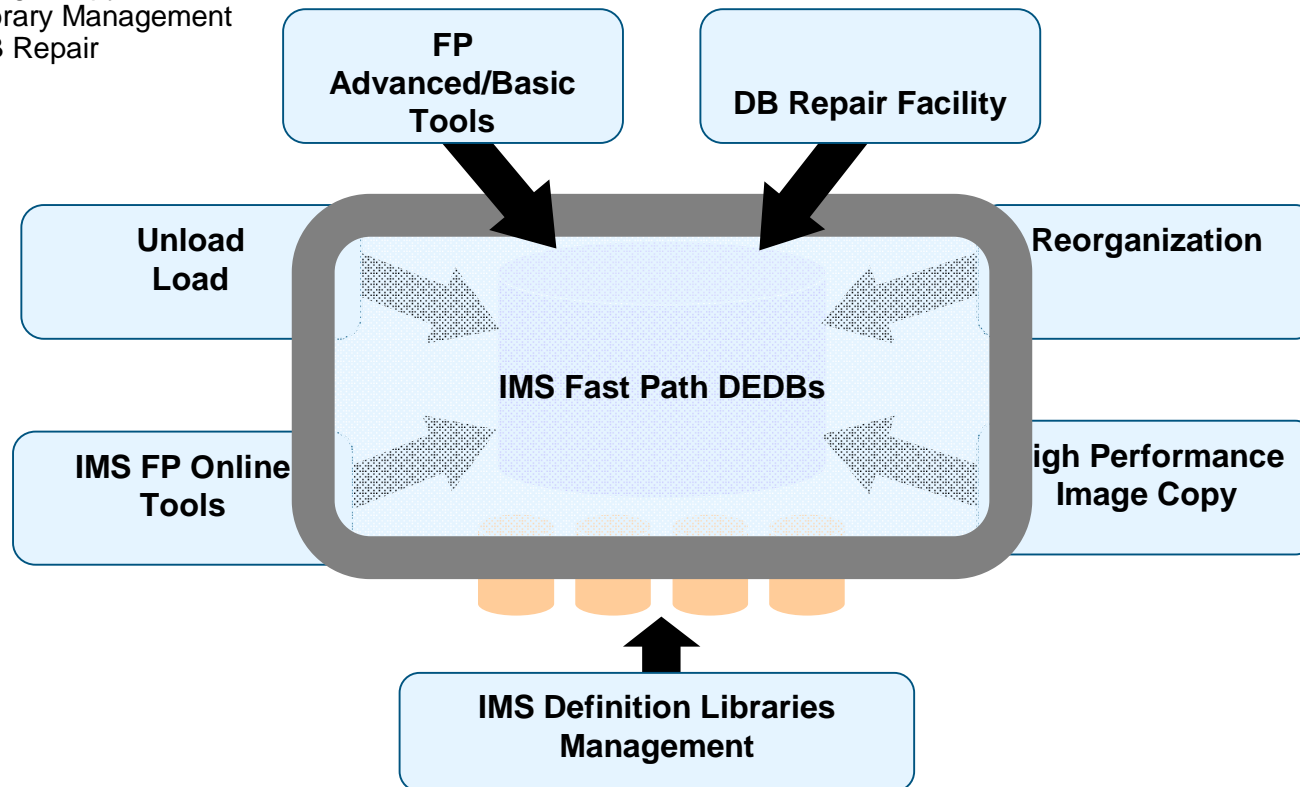



IBM DB2 Tools: *Are you ready for DB2 10?*

- Exploit DB2 10 performance savings out-of-the-box
- Optimize Performance Across Multi-Platform Applications
- Lower CPU costs while reducing batch windows
- Higher data availability through simplified recovery operations



All New with DB2 10!

DB2 Utilities Suite 10 drives down costs with *autonomics, page sampling and further offloads processing to zIIPs and FlashCopy. Developed in conjunction with DB2 10 to provide maximum data integrity and exploit all new functions out of the box.*

DB2 Administration Tool/Object Compare 10.1 extends the value of DB2 10 with new capabilities that allow DBAs to quickly exploit DB2 10 features like *schema evolution. Reduces the overhead of many routine tasks.*

DB2 Sort 1.1 lowers the cost of DB2 Utility sort processing by exploiting advanced features of *System z and z/OS while optimizing overall system efficiency. Significantly reduces batch windows.*

Tivoli OMEGAMON XE for DB2 Performance Expert 5.1 extends its insight into distributed workloads and offers a *robust infrastructure to support DB2 10 subsystem consolidation, with lower monitoring overhead. The recommended performance monitor of DB2 10!*

QMF 10 delivers built-in visualizations and reports that dramatically extend the value to end users. *A new metadata layer simplifies the process to understand and create reports.*

DB2 High Performance Unload 4.1 reduces the cost of extracting DB2 10 data with support for *TCP/IP Pipes and the new internal format as well as a new native XML data unload capability.*



Administer DB2 10 Performance Savings

DB2 Administration Tool 10.1 Exploitation

- **Drive immediate DB2 10 out-of-the-box Performance Savings**
- **Exploit DBA-managed Performance Improvements**
 - Include additional Columns in Indexes to Exploit Index Only Access
 - Convert LOBs to in-line to boost performance
- **Extend Administration Capabilities**
 - Manage new Security models
 - Reduce Schema change overhead
 - Manage Autonomic Statistics collection
- **Time Travel with Temporal Data – “as of”**
 - Record changes in history – System Time
 - Define, update and query events in past or future – Business Time
 - Browse Temporal Data “as of” a point in time with DB2 Table Editor 4.3
- **Plus New Features for DB2 V8, 9 & 10**
 - New “ALT” command to intelligently drive schema changes
 - “NOPAD” option to improve performance with VARCHAR data
 - Recover from Access Path regressions with DB2 9 & 10 Plan Management



Optimize Dynamic Infrastructure Performance

OMEGAMON XE for DB2 Performance Expert 5.1 Exploitation

- **Extended Insight**
 - Surface DB2 for z/OS end-to-end response time metrics
 - Visibility to **all** the components that make up end-user response time
 - Facilitates platform-agnostic identification of response time bottlenecks
 - Enables near-instantaneous response to and prevention of application slowdowns
 - Leverages Tivoli Enterprise Portal GUI
 - Support DB2 9 & 10
- **Summary SQL Reporting**
- **Manage thousands of Threads**
- **Support new DB2 10 Monitoring Data**
- **Lower Monitoring Overhead**

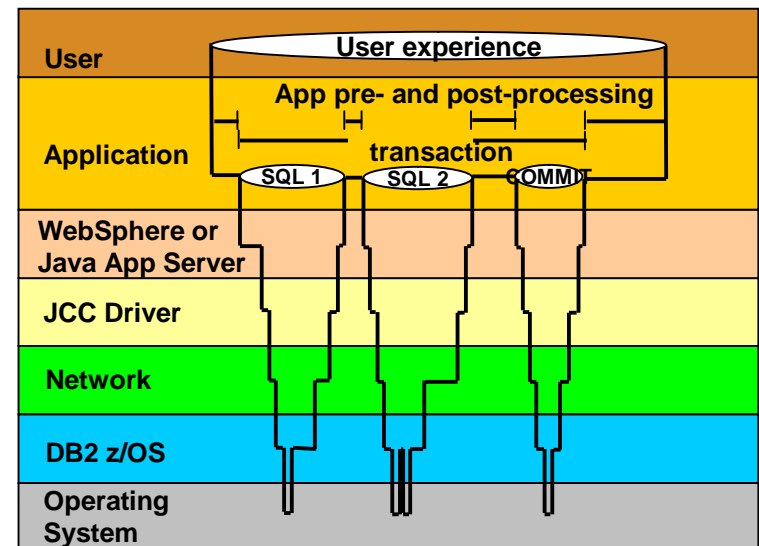



Drive DB2 10 Efficiency & Productivity

DB2 Automation Tool 3.1 Exploitation

- **Autonomic Statistics**
 - Exploit real-time, sampling driven Statistics collection
 - Invoke RUNSTATS with new Profile option
 - Interface with existing Job Schedulers
- **FlashCopy Image Copy**
 - Reduce Batch-windows
 - Reduce CPU consumption with Storage-based Backups
 - Drive improved Recovery Time Objectives
- **Avoid Unnecessary Reorgs**
 - Set REORG thresholds based on DB2 10 Best Practices
 - Detect when Indexes are insensitive to Clustering
 - Avoid REORGs for poorly structured Indexes

Exploit Online Reorgs with DB2 Utilities Enhancement Tool 2.1

- Define policy to cancel Threads immediately before Switch Phase
- Exploit REORG Force option to eliminate Drain Failures
- No changes required to REORG Jobs



Drive DB2 9 & 10 Efficiency & Productivity

DB2 Sort 1.1

- Significant CPU and Elapsed Time reduction in Sort
 - LOAD, REORG, RUNSTATS, REBUILD INDEX, CHECK INDEX, CHECK DATA
 - Presort from DB2 Utilities Enhancement Tool for LOAD REPLACE
- Unique API to allow authorized utilities to invoke the sorting software
- Valuable for customers with large amount of data and aggressive SLA's

Internal Format for up to 4x Load Performance Improvements

- DB2 UNLOAD & LOAD Utilities
- DB2 High Performance Unload 4.1
- Exploit with DB2 Utilities Enhancement Tool 2.1 Constant & Valuelf Options

Unload and Load DB2 Data via USS Pipes & TCP/IP

- DB2 UNLOAD & LOAD Utilities
- DB2 High Performance Unload 4.1

Fast XML Data Unload

- DB2 High Performance Unload 4.1



Exploit DB2 10 for z/OS with IBM DB2 Tools

Accelerate your ability to leverage compelling DB2 10 features with comprehensive Tools support

- Data Encryption Tool for IMS and DB2 Databases
- DB2 Administration Tool / DB2 Object Compare for z/OS
- DB2 Automation Tool for z/OS
- DB2 Bind Manager for z/OS
- DB2 Change Accumulation Tool for z/OS
- DB2 Cloning Tool for z/OS
- DB2 High Performance Unload for z/OS
- DB2 Log Analysis Tool for z/OS
- DB2 Object Restore for z/OS
- DB2 Path Checker for z/OS
- DB2 Query Management Facility for z/OS
- DB2 Query Monitor for z/OS
- DB2 Recovery Expert for z/OS
- DB2 SQL Performance Analyzer for z/OS
- DB2 Table Editor for z/OS
- DB2 Utilities Enhancement Tool for z/OS
- DB2 Utilities Suite for z/OS
- InfoSphere Change Data Capture
- InfoSphere Data Event Publisher
- InfoSphere Guardium S-TAP for DB2 on z/OS
- InfoSphere Replication Server
- Optim Data Growth Solution for z/OS
- Optim Development Studio
- Optim pureQuery Runtime
- Optim Query Workload Tuner
- Optim Test Data Management Solution for z/OS
- Tivoli OMEGAMON XE for DB2 Performance Expert on z/OS



Optim Product Portfolio

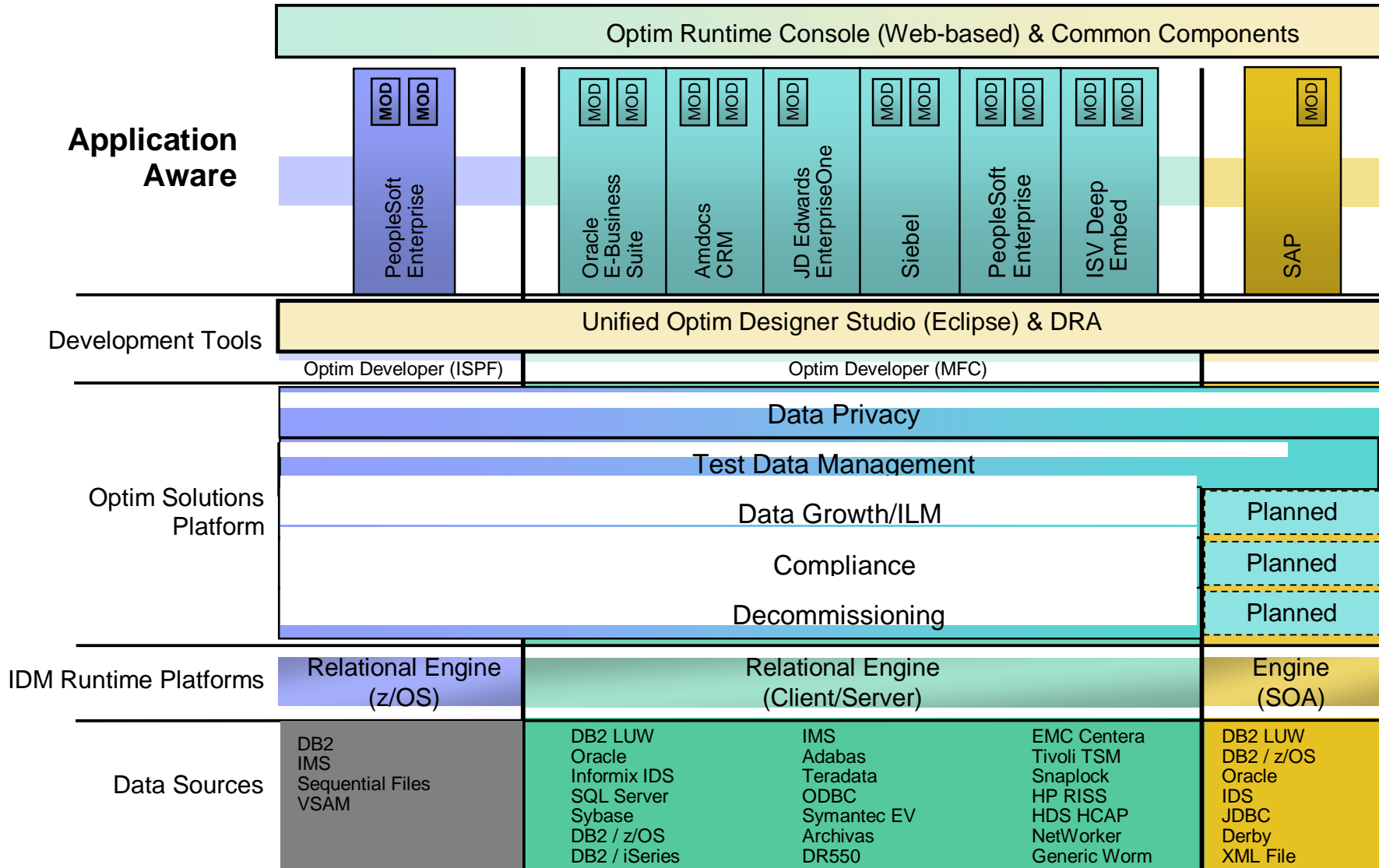

End to End Business Analytics & Data Warehousing Solution on a single platform

➤ IBM System z



➤ InfoSphere Warehouse
➤ Smart Analytics Optimizer

➤ Cognos BI
➤ SPSS Predictive Analytics

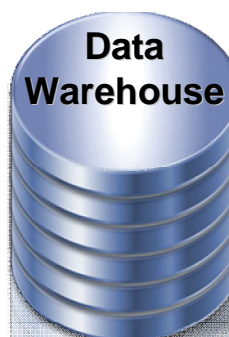

Cubing Services

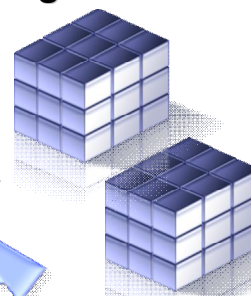

Powercube Services

➤ DB2 for z/OS VUE
➤ DB2 Utilities Suite

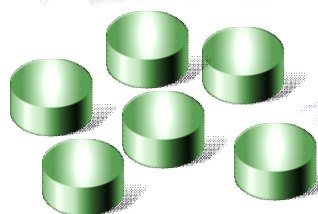

ELT

Operational Source Systems - Structured & Unstructured Data

*Flexible deployment options
Smart Analytics System 9600, Cloud Computing, IBM Services*

IBM Cognos Business Intelligence for Linux on System z



- **Full range of BI capabilities**

- Query, reporting, analysis, dashboarding, realtime monitoring

Business Analytics

- **Delivers information where, when and how it is needed**

- Self-service reporting and analysis
- Automated delivery of information in context
- Author once, consume anywhere

- **Purpose-built SOA platform**

that fits client environments and scales easily



Miami-Dade County

Selects IBM System z platform to expand their IBM Cognos 8 BI enterprise infrastructure



“

...We are now able to expand the usage of our Business Intelligence reporting. By the end of 2010, we will have users from over 42 County departments with over 1500 users creating and consuming reports with stable environments on System z.

”

—Jaci Newmark, Project Lead, Enterprise Business Intelligence Architecture,
Miami-Dade County

- ✓11 days to go from distributed to System z deployment model
- ✓Consolidated multiple BI deployments onto a single platform
- ✓Consolidate multiple, disparate data sources onto a single platform
- ✓Ensured 99.999% availability & complete disaster recovery plan

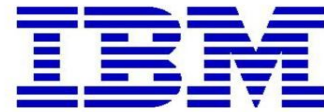

Blue Insight, The IBM internal Private Analytics Cloud



“

*Our commitment to informed decision making led us to consider private cloud delivery of Cognos via System z, which is the enabling foundation that makes possible **+\$25M savings over 5 years.***

”

-IBM CIO Office

- ✓ Consolidated 115 multi-product, departmental BI deployments to 1 Cognos 8 BI on System z
- ✓ Support for our global workforce (2009: 72K, 2010: 130K, 2011: 200K)
- ✓ Realizing value from +60 data sources across IBM
- ✓ Projected \$25M in savings (60% Consolidation, 35% Standardization, 5% Automation)



IBM Cognos BI Total Cost of Ownership Study

Explores the TCO of choosing an x86 based infrastructure vs. System z for a Cognos 8 BI deployment using proven IBM TCO measurement methodology



- ✓ Average savings over 5 years of with a System z deployment: 36%
- ✓ Reduction in high availability costs with System z: 50%
- ✓ System administration savings alone pay for System z investment.



IBM SPSS

- **Full breadth of predictive analytics**
 - Data collection, statistics, data mining, predictive modeling, deployment services...
- **Putting prediction in hands of the business**
 - Decision Management
- **Driving better business outcomes**
 - Attract and retain more profitable customers
 - Detect and prevent fraud
 - Improve resource allocation

Business Analytics

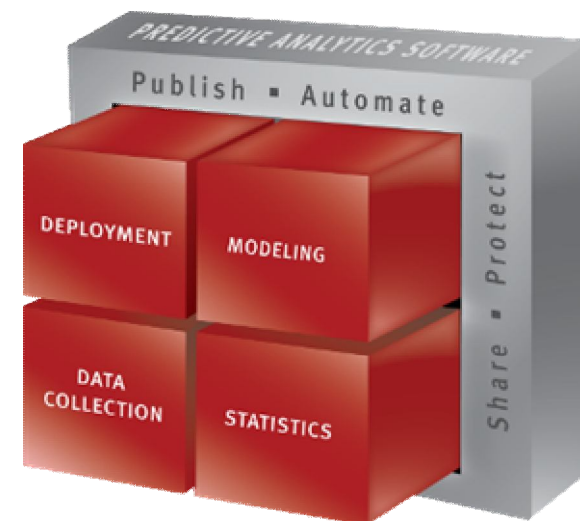

IBM Smart Analytics Optimizer

Capitalizing on the best of both worlds – System z and Netezza

What is it?

The IBM Smart Analytics Optimizer is a workload optimized, appliance add-on, that enables the integration of business insights into operational processes to drive winning strategies. It accelerates select queries, with unprecedented response times.



How is it different

- **Performance:** Unprecedented response times to enable 'train of thought' analyses frequently blocked by poor query performance.
- **Integration:** Connects to DB2 through deep integration providing transparency to all applications.
- **Self-managed workloads:** queries are executed in the most efficient way
- **Transparency:** applications connected to DB2 are entirely unaware of the Optimizer
- **Simplified administration:** appliance hands-free operations, eliminating many database tuning tasks

Breakthrough Technology Enabling New Opportunities

Optimizing to the Workload

Marrying the best of each environment

Total solution remains centrally managed by System z...

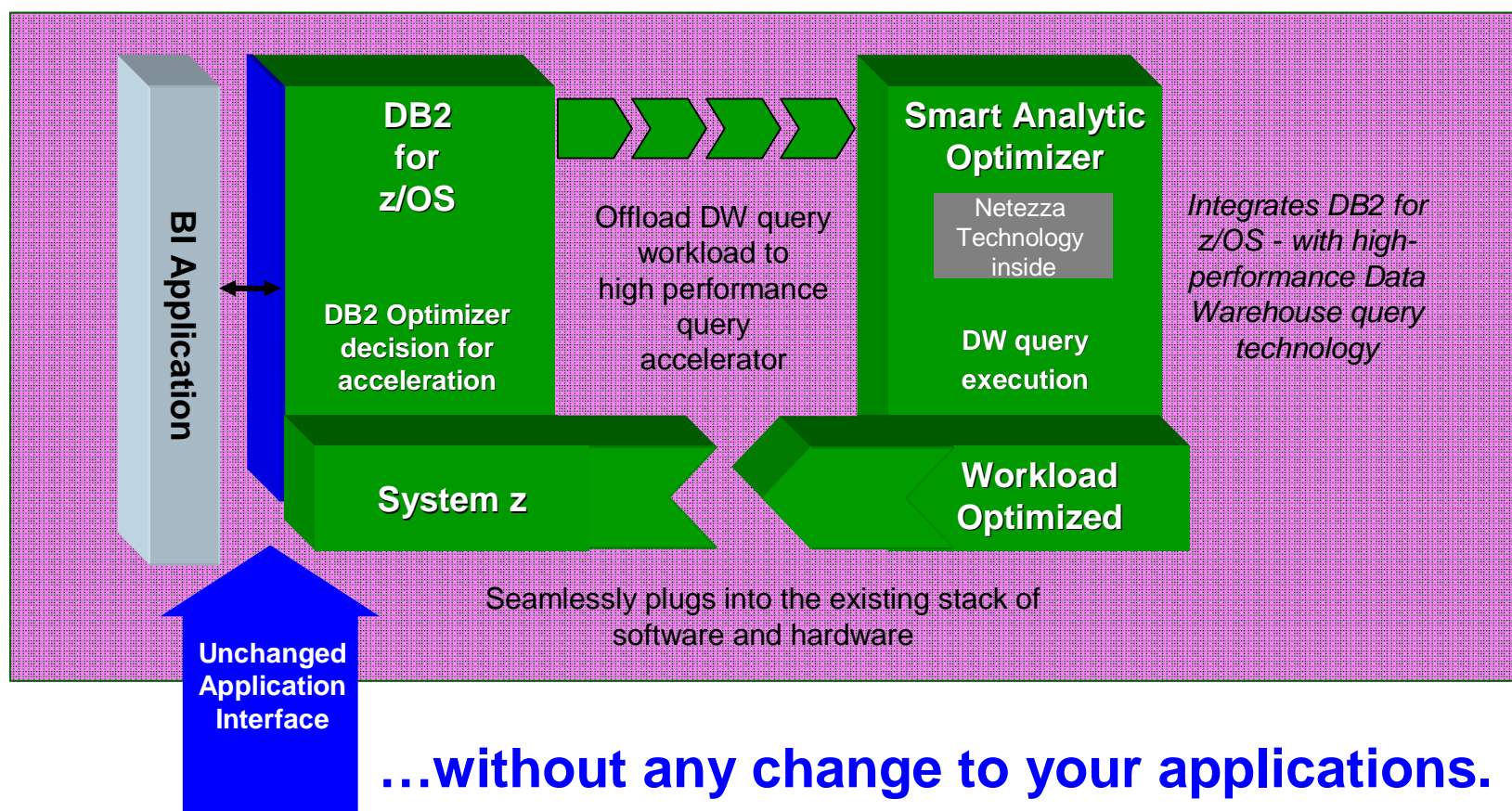

IBM Smart Analytics Optimizer

Continuing to the next version with the original focus

Basic design tenets for version 1 and beyond

- Drive down the costs of data warehousing and business analytics
- Increase the business impact of information analytics
- Provide acceleration that is transparent to the DB2 for z/OS applications
- Capitalize on the qualities of service of System z
- Provide deep integration with DB2
- Replicate data onto the Smart Analytics Optimizer to enable multiple acceleration techniques



Capitalizing on Netezza Technology

- **The Netezza TwinFin® system is the fourth generation Netezza appliance that once again sets the standard for price/performance for [data warehousing and business intelligence](#) (BI).**
- **Blade-based streaming architecture – commodity blades and storage combined with Netezza’s patented data filtering using Field Programmable Gate Arrays (FPGAs)**
- **Appliance simplicity – Easy to deploy and manage; dramatically simplifies your data warehouse and analytics infrastructure**
- **Delivers high performance out of the box, with no indexing or tuning required. With integrated hardware, software and storage leading to shorter deployment cycles and faster time to value for BI and analytic initiatives.**

Extending Smart Analytics Optimizer with Netezza technology

- **Still is a Smart Analytics Optimizer**
- **Uses Netezza technology to perform high speed query**
- **Access to data in terms of authorization and privileges (security aspects) is controlled by DB2 and z/OS (Security Server).**
- **Uses DB2 for z/OS for updates, logging, fast single record look-ups**
- **DB2 for z/OS does backup and recovery and**
- **DB2 for z/OS remains the system of record**
- **There is no external communication to the Smart Analytics Optimizer beyond DB2 for z/OS**

Key Enhancements in V2 Release

- **Extending acceleration to significantly larger number of queries**
- **Expanded size of the data to be accelerated**
- **Improved concurrent query execution**
- **Incremental update by partition**
- **DB2 9 and DB2 10 for z/OS support**
- **Supported only connected to z196/ and zEnterprise forward**

IBM Smart Analytics System 9600

High Value Dynamic Warehousing

System z



InfoSphere Warehouse

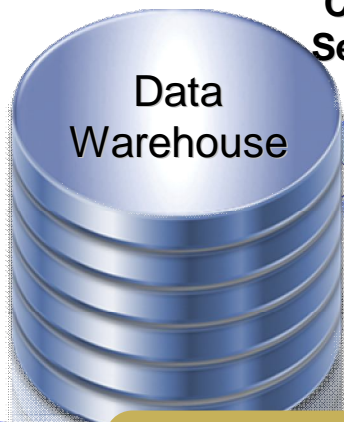

Cubing Services



Powercube Services



Cognos 8 BI

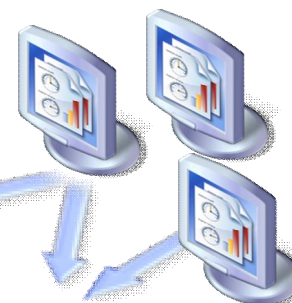

Cognos software

ELT

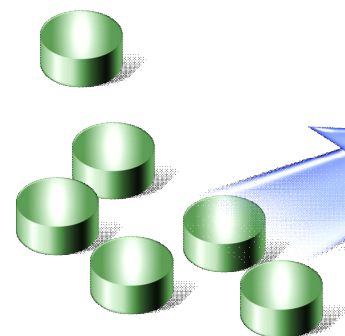

Operational Source Systems
Structured/ Unstructured Data

**DB2 for z/OS VUE
(option for MLC)**

DB2 Utilities Suite

Image Copy, LOAD, UNLOAD,
REORG, etc

Implementation Services





Typical Utilization for Servers

Windows: 5-10% Unix: 10-20% **System z: 85-100%**

System z can help **reduce** your floor space up to **75%-85%** in the data center



Thank You



System z can lower your total cost of ownership, requiring **as little as 30%** of the power of a distributed server farm running equivalent workloads

The cost of storage is typically **three times more** in distributed environments

