

DFS/CFM Synchronous Servomotors

Edition 11/2008

11354313 / EN

Operating Instructions

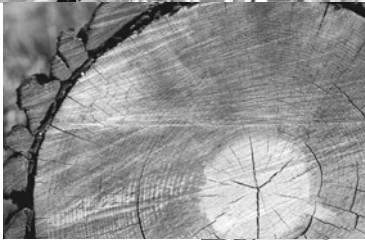



Contents

1	General Notes	5
1.1	How to use the operating instructions	5
1.2	Structure of the safety notes	5
1.3	Rights to claim under limited warranty	6
1.4	Exclusion of liability	6
2	Safety Notes	7
2.1	General information	7
2.2	Target group	8
2.3	Designated use	8
2.4	Other applicable documentation	9
2.5	Transportation/storage	9
2.6	Installation/assembly	9
2.7	Electrical installation	10
2.8	Startup/operation	10
2.9	Inspection/maintenance	10
2.10	Disposal	10
3	Motor Structure	11
3.1	DFS synchronous servomotor – general structure	11
3.2	CFM synchronous servomotor – general structure	12
3.3	Nameplate, unit designation and serial number	13
4	Mechanical Installation	17
4.1	Required tools/resources	17
4.2	Before you begin	17
4.3	Preliminary work	17
4.4	Installing the motor	19
4.5	Mounting tolerances	20
5	Electrical Installation	21
5.1	Assembling the connector	21
5.2	Wiring notes	21
5.3	Connecting the motor and encoder system using SM../SB.. plug connectors	22
5.4	Dimensioning the cable cross section	23
5.5	Power cables for DFS motors	27
5.6	Power cables for CFM motors	32
5.7	Feedback cable for resolver	41
5.8	Feedback cable for HIPERFACE® encoders	47
5.9	Forced cooling fan cable	56
5.10	Cable specification of motor cables for DFS and CFM motors	58
5.11	Cable specification of feedback cables for DFS and CFM motors	62
5.12	Connecting the motor via the terminal box	64
5.13	Connecting the BR brake (CFM motor)	69
5.14	Connecting the B brake (DFS56 motor)	80
5.15	Accessory equipment	84



6	Startup	90
6.1	Prerequisites for startup.....	90
7	Malfunctions	91
7.1	Motor malfunctions.....	91
7.2	Malfunctions when operated with a servo inverter.....	91
7.3	Brake malfunctions	92
8	Inspection/Maintenance	93
8.1	Safety notes regarding inspection/maintenance	93
8.2	Inspection intervals	94
8.3	Inspection work for the B brake (DFS).....	94
8.4	Inspection work for the B brake (CFM)	95
9	Technical Data	100
9.1	Main technical data of the servomotors	100
9.2	Plug connectors	105
9.3	Connection with terminal box.....	105
9.4	Work done, braking torques.....	106
9.5	Brake coil resistance.....	106
9.6	BR brake – operating currents	107
10	Appendix	108
10.1	Crimping tools	108
10.2	SM11/SB11 power connector assembly (for DFS56 servomotor)	111
10.3	Assembly of SM5./SM6. and SB5./SB6. power connectors.....	114
10.4	Assembly of signal plug connectors (resolver/HIPERFACE®).....	115
10.5	Wiring diagrams for DFS/CFM synchronous servomotors.....	118
10.6	Wiring diagram for CFM motors with power connector.....	119
10.7	Wiring diagram for CFM motors with signal connector	119
10.8	Wiring diagram for CFM motors with terminal box.....	121
10.9	Wiring diagram for DFS motors with power connector	123
10.10	Wiring diagram for DFS motors with signal connector.....	123
10.11	Wiring diagram for DFS motors with terminal box	125
10.12	Wiring diagram for VR forced cooling fan	127
11	Address List	128
	Index	137



1 General Notes

1.1 How to use the operating instructions

The operating instructions are an integral part of the product and contain important information for operation and service. The operating instructions are written for all employees who assemble, install, startup, and service this product.

The operating instructions must be accessible and legible. Make sure that persons responsible for the system and its operation, as well as persons who work independently on the unit, have read through the operating instructions carefully and understood them. Consult SEW-EURODRIVE if you have any questions or if you require further information.

1.2 Structure of the safety notes

The safety notes in these operating instructions are structured as follows:

Symbol	! SIGNAL WORD
	Nature and source of hazard. Possible consequence(s) if disregarded. <ul style="list-style-type: none"> • Measure(s) to prevent the hazard.

Symbol	Signal word	Meaning	Consequences if disregarded
Example: General danger	! DANGER	Imminent danger	Severe or fatal injuries
 Specific danger, e.g. electric shock	! WARNING	Possible hazardous situation	Severe or fatal injuries
	! CAUTION	Possible hazardous situation	Minor injuries
	NOTICE	Potential damage to property.	Damage to the drive system or its environment
	TIP	Useful information or tip. Simplifies handling of the drive system.	

**1.3 Rights to claim under limited warranty**

Adhering to the operating instructions is a prerequisite for fault-free operation and the fulfillment of any right to claim under warranty. Therefore, read the operating instructions before you start working with the unit.

1.4 Exclusion of liability

You must comply with the information contained in these operating instructions to ensure safe operation of the electric motors and to achieve the specified product characteristics and performance features. SEW-EURODRIVE does not assume liability for injury to persons or damage to equipment or property resulting from non-observance of these operating instructions. In such cases, any liability for defects is excluded.



2 Safety Notes

The following basic safety notes must be read carefully to prevent injury to persons and damage to property. The operator must ensure that the basic safety notes are read and observed. Make sure that persons responsible for the plant and its operation, as well as persons who work independently on the unit, have read through the operating instructions carefully and understood them. If you are unclear about any of the information in this documentation, please contact SEW-EURODRIVE.

2.1 General information

	DANGER
	<p>Servomotors, gearmotors and gear units may have live, uninsulated, and sometimes moving or rotating parts as well as hot surfaces during operation.</p> <p>Severe or fatal injuries.</p> <ul style="list-style-type: none"> • All work related to transportation, storage, setup/mounting, connection, startup, maintenance and repair may only be carried out by qualified personnel, in strict observation of: <ul style="list-style-type: none"> – The relevant detailed operating instructions – Warning and safety signs on the motor/gearmotor All other project planning documents, operating instructions and wiring diagrams belonging to the drive – The specific regulations and requirements for the system – The national/regional regulations governing safety and the prevention of accidents • Never install damaged products • Immediately report any damages to the shipping company

Removing the required protection cover or the housing without authorization, improper use as well as incorrect installation or operation may result in severe injuries to persons or damage to property.

Refer to the documentation for additional information.



2.2 Target group

Any mechanical work may only be performed by adequately qualified personnel. Qualified personnel in this context are persons who are familiar with the setup, mechanical installation, trouble shooting and maintenance for this product. Further, they are qualified as follows:

- Completed apprenticeship in the field of mechanical engineering (e.g. mechanic or mechatronic technician).
- They are familiar with these operating instructions.

Any electric work may only be performed by adequately qualified personnel. Qualified electricians in this context are persons who are familiar with the electronic installation, startup, trouble shooting and maintenance for this product. Further, they are qualified as follows:

- Completed apprenticeship in the field of electrical engineering (e.g. electric or mechatronic technician).
- They are familiar with these operating instructions.

Any activities regarding transportation, storage, operation, and disposal must be carried out by persons who have been instructed appropriately.

2.3 Designated use

The designated use refers to the procedure specified in the operating instructions.

DFS/CMP synchronous servomotors are drive motors designed for use in industrial and commercial systems. Motor utilization other than that specified (refer to nameplate) and areas of application other than industrial and commercial systems can only be used after consultation with SEW-EURODRIVE.

The DFS/CFM synchronous servomotors meet the requirements stipulated in the low voltage guideline 2006/95/EC. Do not take the unit into operation until you have established that the end product complies with the Machinery Directive 98/37/EC.

You must observe the technical data and information on the connection requirements as provided on the nameplate and in the documentation.

The following applications are prohibited unless the unit is explicitly designed for such use:

- Use in potentially explosive atmospheres
- Use in areas exposed to harmful oils, acids, gases, vapors, dust, radiation, etc.



2.4 Other applicable documentation

The following publications and documents have to be observed as well:

- "SPIROPLAN® W Gear Units, R..7, F..7, K..7, S..7 Series" operating instructions
- "Low Backlash Geared Servomotors (BSF.., PSF..)" catalog
- Operating instructions of the inverter for motors powered by inverters
- Corresponding wiring diagrams

2.5 Transportation/storage

Follow the instructions on transportation, storage and proper handling.

Immediately upon receipt, inspect the shipment for any damage that may have occurred during transportation. Inform the shipping company immediately in the event of damage. If you notice any transport damage, do not startup the motor, consult the SEW-EURODRIVE Service.

Remove securing devices used for transportation prior to startup.

Tighten installed transportation eyebolts. They are designed to only carry the weight of the motor/gearmotor; do not attach any additional loads.

The installed lifting eyebolts comply with DIN 580. The loads and regulations specified in this standard must always be observed. If the gearmotor has 2 suspension eye lugs or lifting eyebolts, then you should also use both suspension eye lugs for attaching transport ropes. In this case, the tension force vector of the slings must not exceed a 45° angle according to DIN 580.

Store the servomotor in a dry, dust-free environment if it is not to be installed straight away.

2.6 Installation/assembly

Comply with the instructions in section 4, "Mechanical Installation" and section 5, "Electrical Installation".

The units must be installed and cooled according to the regulations and specifications in the corresponding documentation.

Protect the synchronous servomotors from excessive strain. Ensure that components are not deformed, particularly during transportation and handling.

The following applications are prohibited unless the unit is explicitly designed for such use:

- Use in potentially explosive atmospheres
- Use in areas exposed to harmful oils, acids, gases, vapors, dust, radiation, etc.



2.7 Electrical installation

Perform electrical installation according to the respective applicable laws, regulations and standards (e.g. cable cross sections, fusing, protective conductor connection). For any additional information, refer to the applicable documentation.

Observe the wiring information and differing data on the nameplate.

Observe the notes in sec. 5, "Electrical Installation".

2.8 Startup/operation

Whenever changes to normal operation occur, such as increased temperatures, noise, vibrations, determine the cause and consult the manufacturer.

Observe the notes in section 6, "Startup".

2.9 Inspection/maintenance

Observe the notes in section 8, "Inspection/Maintenance".

2.10 Disposal

This product consists of:

- Iron
- Aluminum
- Copper
- Plastic
- Electronic components

Dispose the individual components in accordance with the material structure and the regulations in force.



3 Motor Structure



TIP

The following illustrations are intended to explain the general structure. They are to facilitate the assignment of components to the spare parts list. Deviations are possible depending on the motor size and version!

3.1 DFS synchronous servomotor – general structure

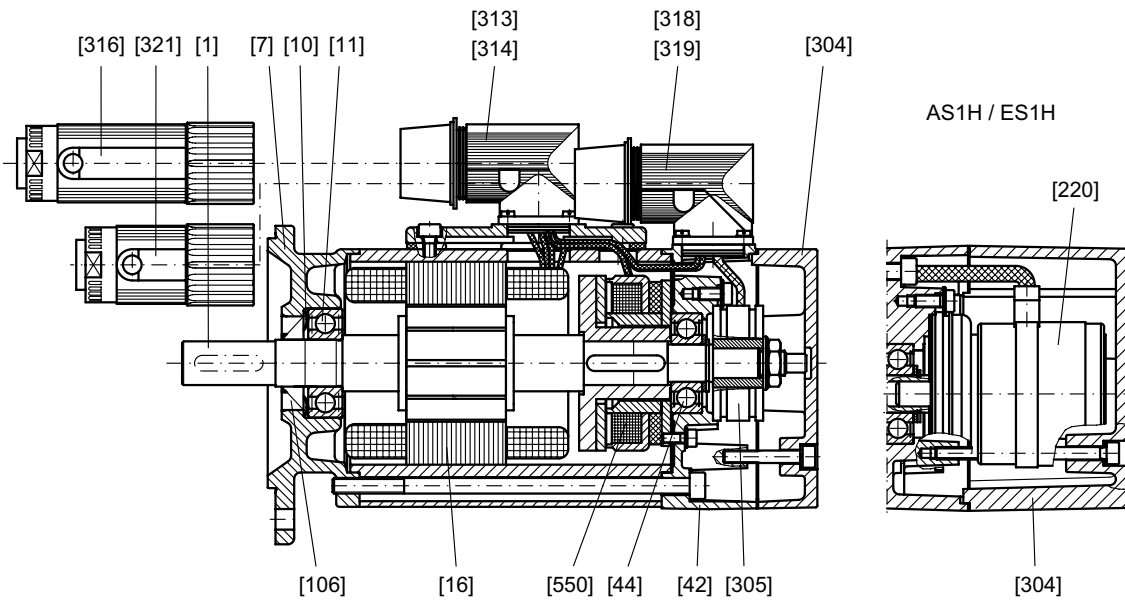

413859723

- | | |
|----------------------------|----------------------------------|
| [1] Rotor | [304] Housing cover |
| [7] Flanged endshield | [305] Resolver |
| [10] Retaining ring | [313] Locking plate |
| [11] Grooved ball bearing | [314] Pin contact power/brake |
| [16] Stator | [316] Power connector, complete |
| [42] B-side endshield | [318] Flange socket complete |
| [44] Grooved ball bearing | [319] Pin contact signal |
| [106] Oil seal without key | [321] Signal connector, complete |
| [220] Absolute encoder | [550] Complete brake |



3.2 CFM synchronous servomotor – general structure

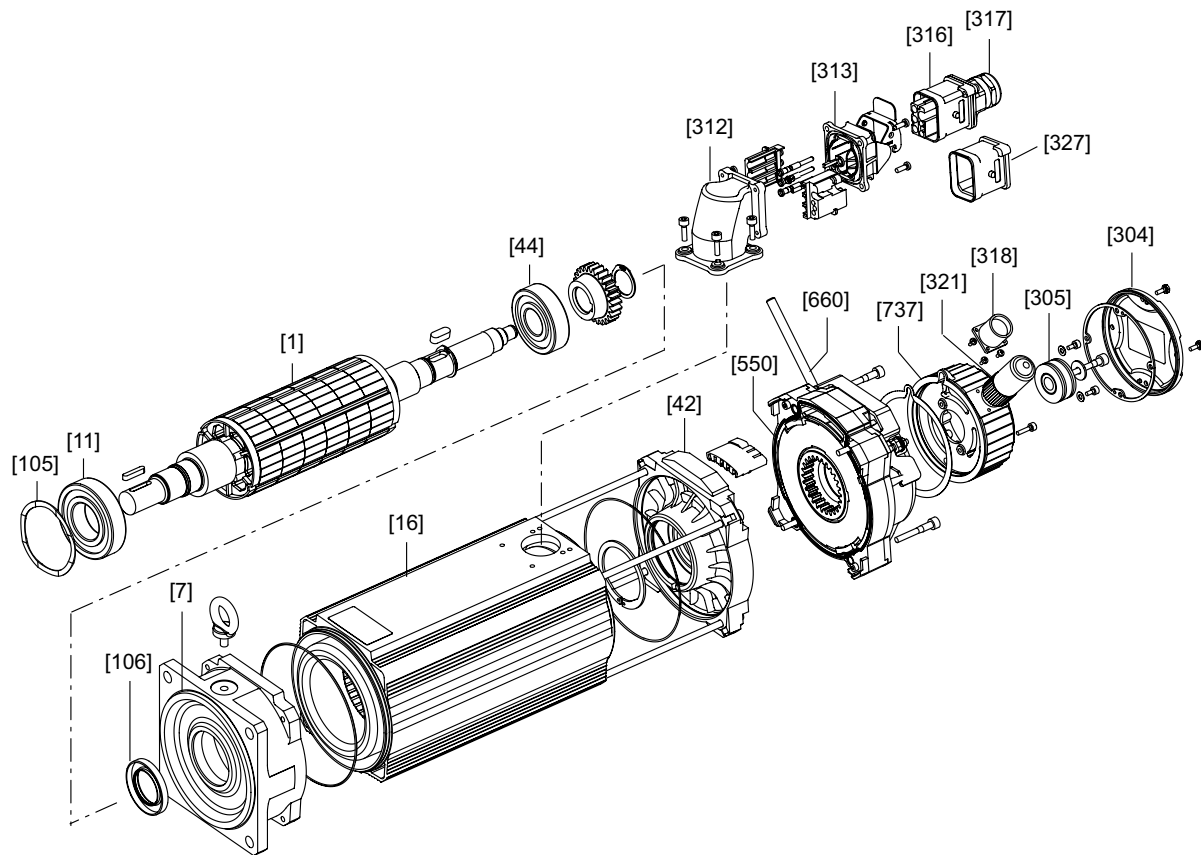

413861259

[1] Rotor	[312] Connector housing
[7] Flanged endshield	[313] Locking plate
[11] Grooved ball bearing	[316] Power connector, complete
[16] Stator	[317] Socket contact
[42] B-side endshield	[318] Flange socket complete
[44] Grooved ball bearing	[321] Signal connector, complete
[105] Shim washer	[327] Cover
[106] Oil seal	[550] Complete brake
[304] Housing cover	[660] Release lever
[305] Resolver	[737] Encoder housing



3.3 Nameplate, unit designation and serial number

3.3.1 Nameplate

Example: CFM 71M /BR /TF /RH1M synchronous brake motor

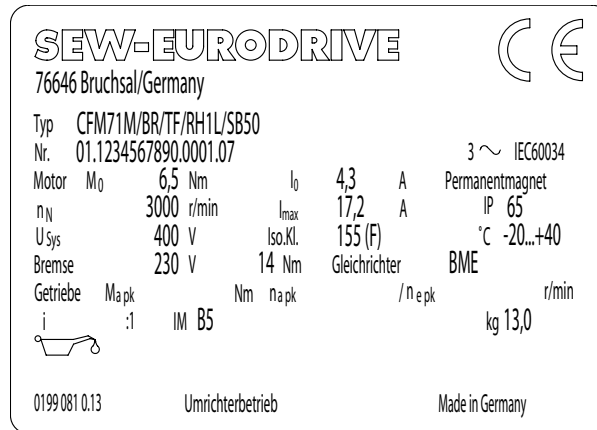

685748747

3.3.2 DFS/CFM unit designations

Synchronous servomotors

DS...	Motor for mounting to size 56 gear units
DFS...	Size 56 in flange-mounted version
CM...	Motor for mounting to gear units of sizes 71/90/112
CFM...	Sizes 71/90/112 in flange-mounted version

Standard equipment for synchronous servomotors

/SM.0	Motor plug connector (socket on motor end only)
/SB.0	Plug connector motor + brake (socket on motor end only)
/RH1M	Resolver
/RH1L	Resolver for brake motors
/TF	Thermistor (PTC resistor)
/KTY	Temperature sensor



Motor Structure

Nameplate, unit designation and serial number

Synchronous servomotor options

/B	Size 56 disk brake
/BR	Size 71/90/112 disk brake
/HR	. . manual brake release with automatic re-engaging function sizes 71/90/112
/SM..	Motor plug connector with code number for size and connection cross section
SB..	Plug connector for motor + brake with code number for size and connection cross section
/ES1H	HIPERFACE® single-turn encoder, spreadshaft, size 56/71/90/112
/AS1H	HIPERFACE® multi-turn encoder, spreadshaft, size 56/71/90/112
/AV1H	HIPERFACE® multi-turn encoder, solid shaft, size 56/71/90/112
/AV1Y	Multi-turn SSI encoder, solid shaft, size 56
/AK0H	Multi-turn SSI encoder, solid shaft, size 56
/EK0H	HIPERFACE® single-turn encoder, spread shaft, size 56
/VR	Forced cooling fan
/KK	Terminal box
/KK5	Terminal box for radial encoder
/KK6	Terminal box for axial encoder

3.3.3 Sample unit designation: DFS synchronous brake motor

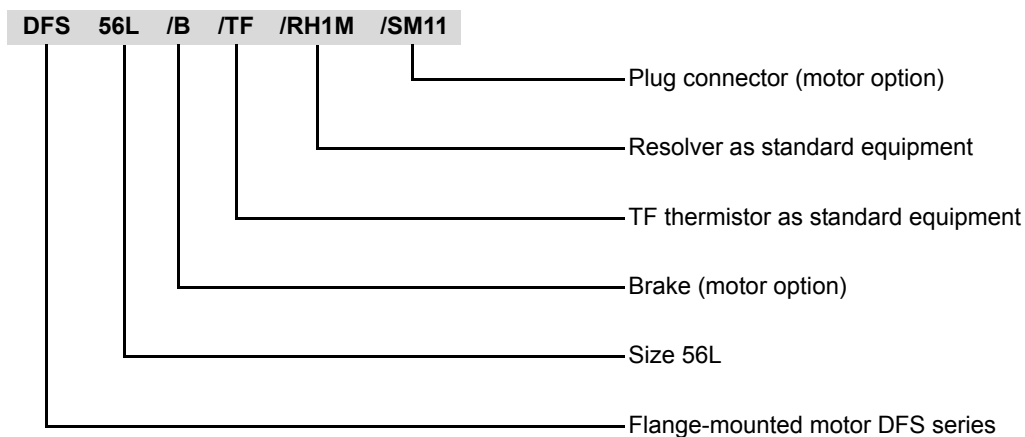



3.3.4 Sample unit designation: CFM synchronous brake motor

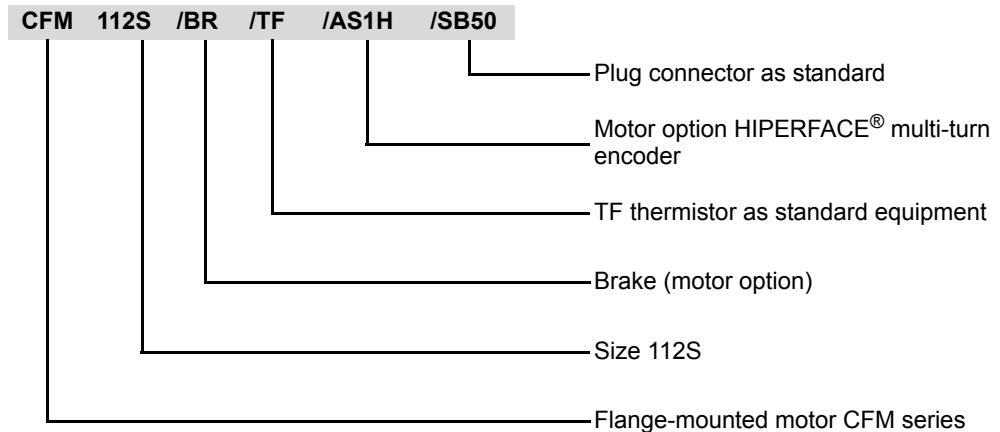

3.3.5 Scope of delivery for SEW-EURODRIVE motors

The scope of delivery for SEW-EURODRIVE servomotors includes for **standard motors**:

Delivery with order confirmation	1 x Operating instructions in the language of the corresponding country, if requested. When ordering several servo gear units, the customer can reduce the number of operating instructions. 1 x Safety notes for startup, if requested 1 x Spare parts list if requested
Delivery with drive	1 x Motor according to order confirmation
Pre-fabricated cable	1 x Bag with loose parts including conductor end sleeves and cable lugs for connection to SEW-EURODRIVE inverters.
Forced cooling fan	1 x Power connector 1 x Power socket 4 x Hex head screw 4 x Square nut
Plug connector	1 x Encoder connector (radial or axial) 10 x Crimp socket contacts for encoder connector for core cross sections of 0.25 mm ² to 0.5 mm ² . 1 x SM50 mating connector for motor power cable 4 x Crimp socket contacts for power connection for core cross sections of 1.5, 2.5, 4, 6 or 10 mm ²



Motor Structure

Nameplate, unit designation and serial number

The scope of delivery for SEW-EURODRIVE servomotors includes for **brakemotors**:

Delivery with order confirmation	1 x Operating instructions in the language of the corresponding country, if requested. When ordering several servo gear units, the customer can reduce the number of operating instructions. 1 x Safety notes for startup, if requested 1 x Spare parts list if requested
Delivery with drive	1 x Motor according to order confirmation
Pre-fabricated cable	1 x Bag with loose parts including conductor end sleeves and cable lugs for connection to SEW-EURODRIVE inverters
Brake	1 x AC-operated BME brake rectifier for DIN rail mounting, or alternatively: <ul style="list-style-type: none"> - BMP, BMH or BMK brake rectifier - BSG brake control unit at a voltage of DC 24 V 1 x Manual release lever if brake with manual release was ordered
Forced cooling fan	1 x Power connector 1 x Power socket 4 x Hex head screw 4 x Square nut 4 x Mounting bracket
Plug connector	1 x Encoder connector (radial or axial) 10 x Crimp socket contacts for encoder connector for core cross sections of 0.25 mm ² to 0.5 mm ² 1 x SB50 mating connector for motor power and brake cable 4 x Crimp socket contacts for power connection for core cross sections of 1.5, 2.5, 4, 6 or 10 mm ² 3 x Crimp socket contacts for brake connection for core cross sections of 1 mm ² or 1.5 mm ²

3.3.6 Example: Serial number

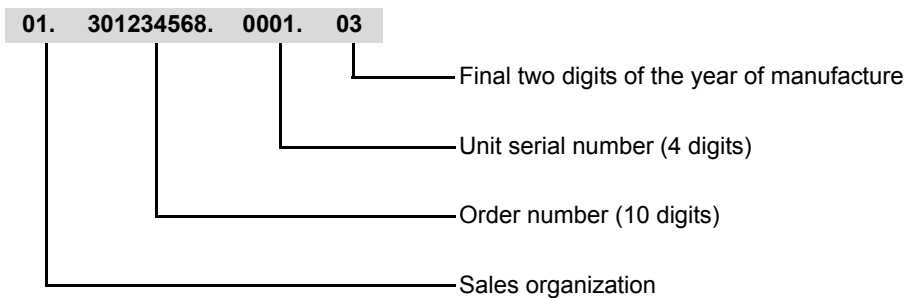



4 Mechanical Installation

4.1 Required tools/resources

- Standard tools
- Mounting device
- Operation with conductor end sleeves: Crimping tool and conductor end sleeves
- Crimping tool for plug connectors
- Removal tool

4.2 Before you begin

The drive may only be installed if

- The specifications on the drive's nameplate and/or the output voltage of the frequency inverter match the voltage supply system
- The drive is undamaged (no damage caused by transportation or storage).
- You are certain that the following requirements have been fulfilled:
 - Ambient temperature between -20 °C and $+40\text{ °C}$
 - No oil, acid, gas, vapors, radiation, etc.
 - Installation altitude max. 1000 m above sea level
 - Special designs: Drive configured in accordance with the ambient conditions

4.3 Preliminary work

Motor shaft ends must be thoroughly cleaned of anti-corrosion agents, contamination or similar (use a commercially available solvent). Make sure that the solvent does not come into contact with the bearing or sealing rings as it may damage the material.

	NOTICE
	<p>The bearing and the sealing rings can be damaged if exposed to solvents. Potential damage to property.</p> <ul style="list-style-type: none"> • Protect the bearing and sealing rings from exposure to solvents.

4.3.1 Installation after extended storage

- Note that the service life of the lubricant in the ball bearings is reduced by 10% per year after the first year of storage.
- Check whether the motor has absorbed moisture as a result of being stored for a long time. Measure the insulation resistance for this purpose (measuring voltage DC 500 V).



The insulation resistance (see following figure) varies greatly depending on the temperature. The motor must be dried if the insulation resistance is not adequate.

The following figure shows the insulation resistance depending on the temperature.

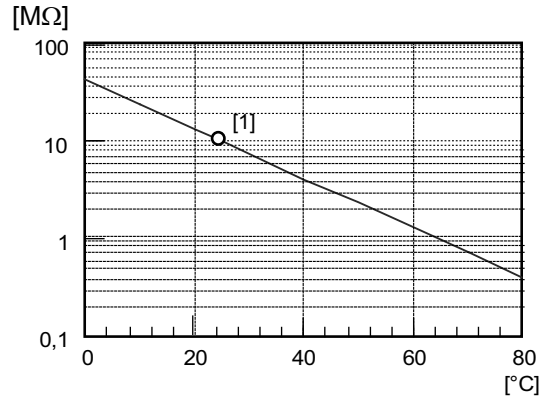

413914507

4.3.2 Drying the motor



TIP

Insulation resistance too low:

→ Servomotor has absorbed moisture

Measure:

- Use hot air to heat up the motor.
- Open the motor compartment enough for moisture to escape from the inside.

Next check whether:

- The wiring space is dry and clean.
- The connections and fastening parts are free from corrosion.
- The joint seal is functioning.
- The cable glands are tight, otherwise clean or replace them.



4.4 Installing the motor

	NOTICE
	<p>Improper mounting may result in damages to the motor.</p> <p>Potential damage to property.</p> <ul style="list-style-type: none"> • Only install the motor in the specified mounting position on a level, vibration-free, and torsionally rigid support structure. • Align the motor and the driven machine carefully to avoid placing any unacceptable strain on the output shafts. • Observe permitted overhung and axial loads → "Low Backlash Servo Gearmotors (BSF., PSF.)" catalog. • Do not butt or hammer the shaft end.

	NOTICE
	<p>Vertical designs with VR forced-cooling fan can get damaged by foreign objects or moisture.</p> <p>Potential damage to property.</p> <ul style="list-style-type: none"> • Protect vertical designs with VR forced-cooling fan with corresponding covers.

If a forced cooling fan is used, ensure there is sufficient clearance around the unit to allow for adequate cooling. Make sure that the unit does not suck in hot outgoing air from other units.

Components with a keyway to be mounted belatedly on the shaft must be balanced using a half key. Motor shafts may be balanced with a half key (vibration level "N" to EN/IEC 600 34). You must not operate the motor without a key.



4.4.1 Installation in damp locations or in the open

- Try to arrange the motor and encoder connection so that the connector cables do not point upwards.
- Coat the threads of the cable glands and filler plugs with sealing compound and tighten them properly. Then coat them again.
- Clean the sealing surfaces of the connector (motor and/or encoder connection) before reassembly.
- Replace any brittle seals.
- If necessary, restore the anticorrosive paint coat.
- Check that the degree of protection is maintained.

4.5 Mounting tolerances

Shaft end	Flanges
Diameter tolerance according to EN 50347 <ul style="list-style-type: none"> • ISO k6 • Center bore in accordance with DIN 332, shape DR.. 	Centering shoulder tolerance in accordance with EN 50347 <ul style="list-style-type: none"> • ISO j6



5 Electrical Installation

	<p>⚠ DANGER</p>
	<p>Risk of injury due to electric shock.</p> <p>Severe or fatal injuries.</p> <ul style="list-style-type: none"> • It is essential to comply with the safety notes in section 2 during installation. • Use switch contacts in utilization category AC-3 to EN 60947-4-1 for connecting the motor and the brake. • When motors are powered from inverters, you must adhere to the wiring instructions issued by the inverter manufacturer. • Observe the operating instructions for the servo inverter.

5.1 Assembling the connector

	<p>NOTICE</p>
	<p>If the connector is tightened when it is installed in the wrong position, the insulator could slip, causing irreparable damage.</p> <p>Potential damage to property.</p> <p>Note the following when plugging in the power and signal connectors:</p> <ul style="list-style-type: none"> • Check that the connector is installed in the correct position. • Check that the detent on the connector is positioned correctly. • Make sure that the connector lock can be turned without having to apply too much force.

5.2 Wiring notes

5.2.1 Protection against interference by brake controllers

Do not route unshielded brake cables alongside switched-mode power cables, since brake controllers may cause interference.

Switched-mode power cables include in particular:

- Output cables from frequency inverters and servo inverters, converters, soft start units and brake units
- Supply cables to braking resistors and similar.

5.2.2 Thermal motor protection

Install the connecting lead of the TF/KTY separately from other power cables, maintaining a distance of at least 200 mm. Collective installation is only permitted if either the TF / KTY cable or the power cable is shielded.



5.3 Connecting the motor and encoder system using SM../SB.. plug connectors

The DFS/CFM motors are supplied with the SM../SB.. plug connector system. In the basic version, SEW-EURODRIVE delivers DFS/CFM motors with a flange socket on the motor end and without mating connector. The encoder system is connected using a separate 12-pin round plug connector. The standard encoder cable entry is axial for the DFS motor and radial for the CFM motor.

5.3.1 Cable cross section

Make sure that the type of cable complies with the applicable regulations. The rated currents are specified on the nameplate. The cable cross sections that can be used are listed in the following table.

Type	Cable type	Cable cross section	
		[mm ²]	[AWG]
SM11/SM51/SM61	Motor cable	4 x 1.5 mm ²	AWG 16
SM52/SM62		4 x 2.5 mm ²	AWG 14
SM54/SM64		4 x 4 mm ²	AWG 12
SM56/SM66		4 x 6 mm ²	AWG 10
SM59/SM69		4 x 10 mm ²	AWG 8
SB11	Brakemotor cable	4 x 1.5 mm ² + 2 x 1 mm ²	AWG 16 + AWG 18
SB51/SB61		4 x 1.5 mm ² + 3 x 1 mm ²	AWG 16 + AWG 18
SB52/SB62		4 x 2.5 mm ² + 3 x 1 mm ²	AWG 14 + AWG 18
SB54/SB64		4 x 4 mm ² + 3 x 1 mm ²	AWG 12 + AWG 18
SB56/SB66		4 x 6 mm ² + 3 x 1.5 mm ²	AWG 10 + AWG 16
SB59/SB69		4 x 10 mm ² + 3 x 1.5 mm ²	AWG 8 + AWG 16

5.3.2 Prefabricated cables

Pre-fabricated cables are available from SEW-EURODRIVE to connect the SM../SB.. plug connector system. The core designation and contact assignment are listed in the following tables.

Observe the following when you assemble the cables yourself:

- Section 10 describes the assembly of the SM1./SB1., SM5./SM6., SB5./SB6 power connectors and the signal connector.
- The socket contacts for the motor connection are designed as crimp contacts. Only use suitable tools for crimping.
- Strip the insulation of the leads according to section 10.
- Use suitable removal tools to remove incorrectly installed socket contacts.
- Install the insulator in the signal connectors on the motor end at "zero" degree (center position). Observe this coding on the cable end.
- Cable relief according to EN 61984 and EN 60529 is influenced by the tightening torque of the screw. The tightening torque must be matched to the cable.



5.4 Dimensioning the cable cross section

5.4.1 Cable dimensioning according to EN 60402

The following figure shows the minimum required cable cross section depending on cable length l [m] and current I [A].

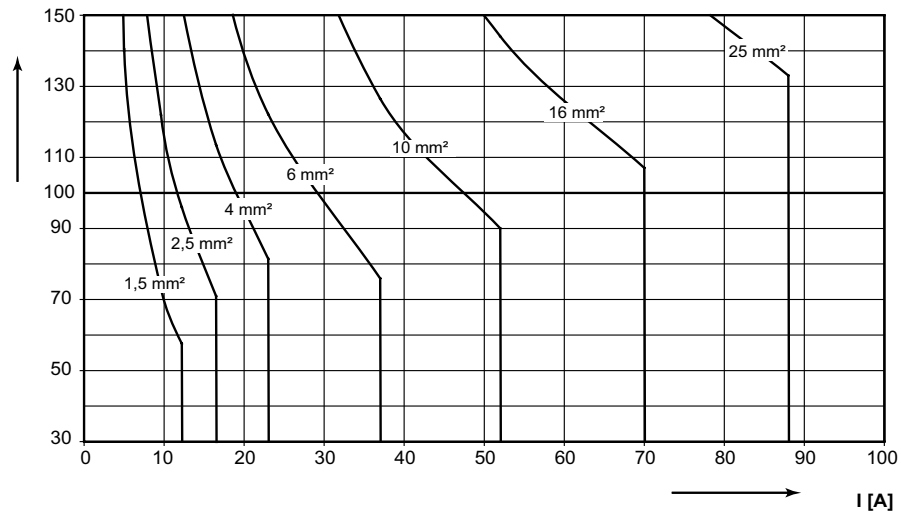

576701195

Hybrid cables with cross sections of 1.5 mm² (AWG 16) to 10 mm² (AWG 8) can be ordered from SEW-EURODRIVE.



5.4.2 Cable load table

Cable load through current I in [A] according to EN 60204-1 table 5, ambient temperature 40 °C.

Cable cross section		Triple-core, plastic-sheathed cable in Duct or cable	Triple-core, plastic-sheathed cable on top of each other on wall	Triple-core, plastic-sheathed cable next to each other, horizontal
[mm ²]	[AWG]	[A]	[A]	[A]
1,5	AWG 16	12,2	15,2	16,1
2,5	AWG 14	16,5	21,0	22
4	AWG 12	23	28,0	30
6	AWG 10	29	36,0	37
10	AWG 8	40	50,0	52
16	AWG 6	53	66,0	70
25	AWG 4	67	84,0	88
35	AWG 2	83	104,0	114

These data are merely recommended values and are **no substitute for the detailed project planning** of the cables depending on the concrete application considering the applicable regulations.

Observe the voltage drop that occurs along the cable in particular with the DC 24 V brake coil when dimensioning the cross sections for the brake cable. The accelerator current is decisive for the calculation.



5.4.3 Assignment of servomotor and cable cross section

Rated speed n_N [rpm]	Motor	M_0 [Nm]	400 V		230 V	
			I_0 [A]	SM SB	I_0 [A]	SM SB
2000	CFM71S	5	2.2	51 / 61	3.95	51 / 61
	CFM71M	6.5	3	51 / 61	5.3	51 / 61
	CFM71L	9.5	4.2	51 / 61	7.4	52 / 62
	CFM90S	11	4.9	51 / 61	8.7	52 / 62
	CFM90M	14.5	6.9	51 / 61	12.1	54 / 64
	CFM90L	21	9.9	51 / 61	17.1	56 / 66
	CFM112S	23.5	10	51 / 61	18.0	56 / 66
	CFM112M	31	13.5	52 / 62	24.5	59 / 69
	CFM112L	45	20	54 / 64	35.5	59 / 69 ¹⁾
	CFM112H	68	30.5	59 / 69	–	–
3000	DFS56M	1	1.65	11	1.65	11
	DFS56L	2	2.4	11	2.4	11
	DFS56H	4	2.8	11	–	–
	CFM71S	5	3.3	51 / 61	5.9	51 / 61
	CFM71M	6.5	4.3	51 / 61	7.6	52 / 62
	CFM71L	9.5	6.2	51 / 61	11.1	54 / 64
	CFM90S	11	7.3	51 / 61	12.7	54 / 64
	CFM90M	14.5	10.1	51 / 61	17.4	56 / 66
	CFM90L	21	14.4	52 / 62	25.5	59 / 69
	CFM112S	23.5	15	52 / 62	27	59 / 69
	CFM112M	31	20.5	54 / 64	35	59 / 69
	CFM112L	45	30	59 / 69	48	–
	CFM112H	68	43	–	–	–
	4500	DFS56M	1	1.65	11	–
DFS56L		2	2.4	11	–	–
DFS56H		4	4	11	–	–
CFM71S		5	4.9	51 / 61	8.5	52 / 62
CFM71M		6.5	6.6	51 / 61	11.3	54 / 64
CFM71L		9.5	9.6	51 / 61	17.1	56 / 66
CFM90S		11	11.1	51 / 61	18.9	56 / 66
CFM90M		14.5	14.7	52 / 62	26	59 / 69
CFM90L		21	21.6	54 / 64	39	59 / 69 ¹⁾
CFM112S		23.5	22.5	54 / 64	38.5	59 / 69 ¹⁾
CFM112M		31	30	56 / 66	54	–
CFM112L		45	46	59 / 69 ¹⁾	–	–
CFM112H		68	66	–	–	–
6000		DFS56M	1	1.65	11	–
	DFS56L	2	2.75	11	–	–
	DFS56H	4	5.3	11	–	–
	CFM71S	5	6.5	51 / 61	11.6	54 / 64
	CFM71M	6.5	8.6	51 / 61	14.1	54 / 64
	CFM71L	9.5	12.5	52 / 62	21.5	59 / 69
	CFM90S	11	14.5	52 / 62	23.5	59 / 69
	CFM90M	14.5	19.8	54 / 64	37	59 / 69 ¹⁾
	CFM90L	21	29.5	56 / 66	51	–

1) For UL application only with terminal box

The suggested cross sections for 230 V are sufficient for NFPA 79 and UL 508 (without 1). Further DFS/230 V motor variants are available on request



Electrical Installation

Dimensioning the cable cross section

**TIP**

The assignments of SM/SB plug connectors are not binding. Given the dynamic properties in the system, other cross sections can also be implemented.



5.5 Power cables for DFS motors

5.5.1 Structure of the motor cables and brakemotor cables for DFS motors

The following figure shows the structure of the motor cables and brakemotor cables:

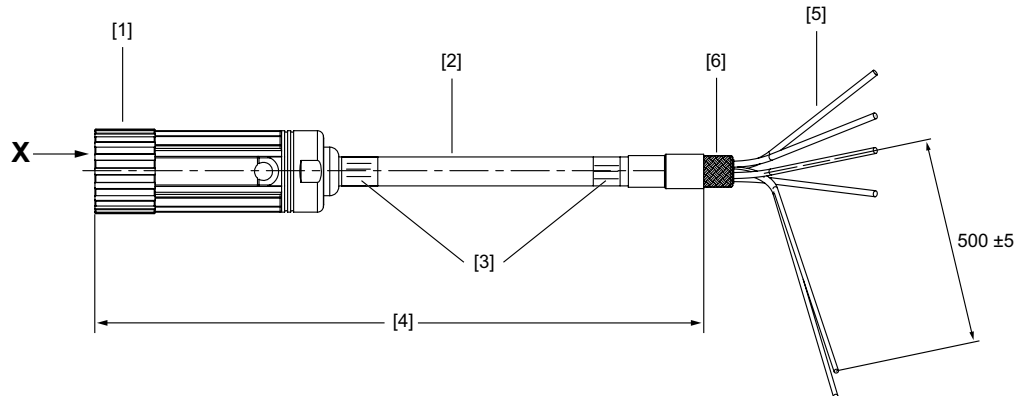

413916043

- [1] Connector: Intercontec BSTA 078
- [2] SEW-EURODRIVE logo printed on cable
- [3] Nameplate
- [4] Cable length ≤ 10 m: Tolerance +200 mm
Cable length ≥ 10 m: Tolerance +2%
Permitted line length according to the technical documents.
- [5] Prefabricated cable end for inverter
Required loose parts are supplied with the cable.
- [6] Shielding 20 mm, pulled back approximately + 5 mm

Motor side

The motor cables on the motor side consist of an 8-pin plug connector and socket contacts.

The shield is connected in the connector housing according to EMC requirements. All plug connectors seal the plug on the cable end with a lamellar seal and ensure cable relief according to EN 61884.

Inverter side

The individual cable cores of the motor and brakemotor cables are exposed and the shield is prepared for connection in the control cabinet. The cable for the inverter end has yet to be assembled. The loose parts required are supplied with the cable in a separate bag.

Loose parts

The following loose parts are supplied in accordance with the core cross sections for connection to the power terminals on the inverter:

Bag no.	Content
1	4 x conductor end sleeves 1.5 mm ² , insulated 4 x M6 U-shaped cable lugs 1.5 mm ²



5.5.2 Motor cable for DFS motors

DFS motor cable

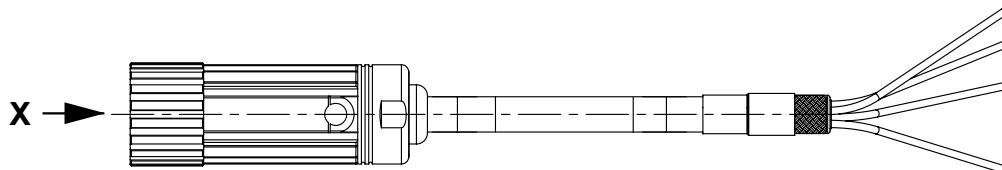

413917579

DFS motor cable types

Plug connector type	Number of cores and cable cross section	Installation	Part number
SM11	4 × 1.5 mm ² (AWG 16)	Fixed installation	0590 4544
SM11	4 × 1.5 mm ² (AWG 16)	Cable carrier installation	0590 6245

DFS motor cable – pin assignment

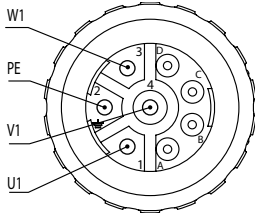
Plug connector View X	Pin	Cable core color	Assigned	Extra
BSTA 078 0198 6740 8-pole with socket contacts 	1	(BK) Black	U	Bag of loose parts
	2	(GN/YE) Green/yellow	PE	
	3	(BK) Black	W	
	4	(BK) Black	V	

DFS motor cable – alternative plug connector

Plug connectors for power supply with socket contacts (complete).

Plug connector type	Number of cores and cable cross section	Installation	Part number
SM11	4 × 1.5 mm ² (AWG 16)	Fixed installation / cable carrier installation	0198 6740



5.5.3 DFS motor cable – extension cable

Extension cable for DFS motor cable:

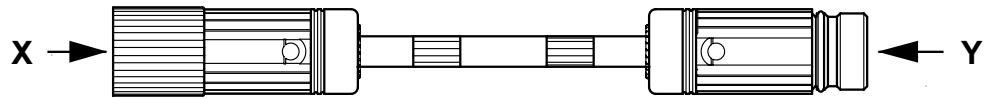

413920651

DFS motor cable – types of extension cables

Plug connector type	Number of cores and cable cross section	Installation	Part number
SM11	4 × 1.5 mm ² (AWG 16)	Cable carrier installation	1333 2457

DFS motor extension cable – pin assignment

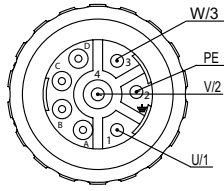
Plug connector View X	Pin	Cable core color	Assigned	Pin	Plug connector View Y
BSTA 078 0198 6740 8-pin with socket contacts	1	(BK/WH) Black with white lettering U, V, W	U	1	BKUA 199 1333 2430 8-pin with pin contacts 
	2	(GR/YE) Green/yellow	PE	2	
	3	(BK/WH) Black with white lettering U, V, W	W	3	
	4	(BK/WH) Black with white lettering U, V, W	V	4	

Extension cable for DFS motor cable – alternative plug connector

Plug connector with pins (complete) for motor extension cable.

Plug connector type	Number of cores and cable cross section	Installation	Part number
SM11	4 × 1.5 mm ² (AWG 16)	Fixed installation / cable carrier installation	1333 2430



5.5.4 Brakemotor cable for DFS motors

DFS brakemotor cable:

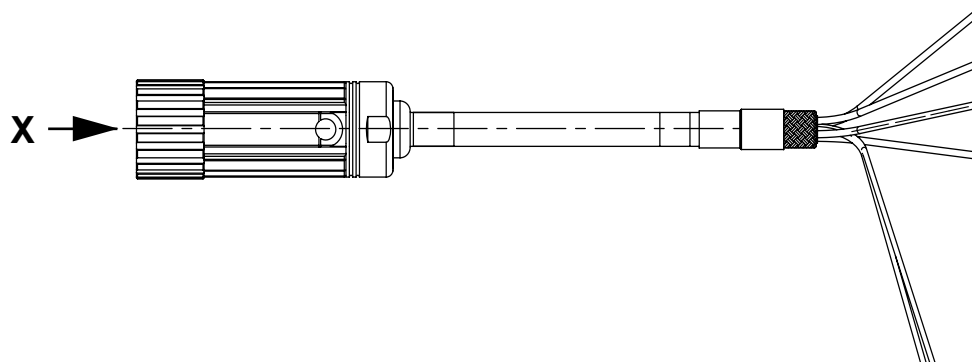

413939083

DFS brakemotor cable types

Plug connector type	Number of cores and cable cross section	Installation	Part number
SB11	4 × 1.5 mm ² (AWG 16) + 2 × 1 mm ² (AWG 18)	Fixed installation	1332 4853
SB11	4 × 1.5 mm ² (AWG 16) + 2 × 1 mm ² (AWG 18)	Cable carrier installation	1333 1221

DFS brakemotor cable – pin assignment

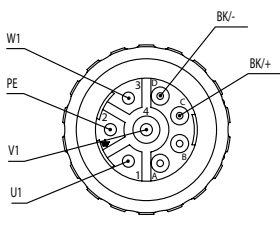
Plug connector View X	Pin	Cable core color	Assigned	Extra
BSTA 078 0198 6740 0198 9197 8-pin with socket contacts 	1	(BK/WH) Black with white lettering U, V, W	U	Bag of loose parts
	2	(GN/YE) Green/yellow	PE	
	3	(BK/WH) Black with white lettering U, V, W	W	
	4		V	
	A	–	n. c.	
	B	–	n. c.	
	C	(BK/WH)	2	
	D	Black with white lettering 1, 2	1	

DFS brakemotor cable – alternative plug connector

Plug connectors for power supply with socket contacts (complete).

Plug connector type	Number of cores and cable cross section	Installation	Part number
SM11/SB11	4 × 1.5 mm ² (AWG 16) + 3 × 1 mm ² (AWG 18)	Fixed installation	0198 6740
SM11/SB11	4 × 1.5 mm ² (AWG 16) + 3 × 1 mm ² (AWG 18)	Cable carrier installation	0198 9197



5.5.5 Brakemotor extension cable for DFS motors

Brakemotor extension cable:

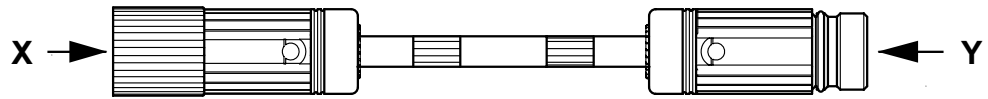

413920651

Types of brakemotor extension cables for DFS motors

Plug connector type	Number of cores and cable cross section	Installation	Part number
SB11	4 × 1.5 mm ² (AWG 16) + 2 × 1 mm ² (AWG 18)	Cable carrier installation	1333 2481

DFS brakemotor extension cable – pin assignment

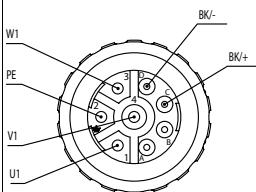
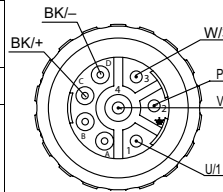
Plug connector View X	Pin	Cable core color	Assigned	Pin	Plug connector View Y
BSTA 078 0198 9197 8-pin with socket contacts 	1	Black with white lettering U, V, W (BK/WH)	U	1	BKUA 199 1333 2430 8-pin with pin contacts 
	2	Green/yellow (GN/YE)	PE	2	
	3	Black with white lettering U, V, W (BK/WH)	W	3	
	4		V	4	
	A	–	n. c.	A	
	B	–	n. c.	B	
	C	Black with white lettering 1, 2, 3 (BK/WH)	2	C	
	D		1	D	

Plug connector with pins (complete) for brakemotor extension cable.

Plug connector type	Number of cores and cable cross section	Installation	Part number
SM11/SB11	4 × 1.5 mm ² (AWG 16) + 2 × 1 mm ² (AWG 18)	Cable carrier installation	1333 2430



5.6 Power cables for CFM motors

5.6.1 Structure of the motor cables and brakemotor cables for CFM motors

The following figure shows the structure of the motor cables and brakemotor cables:

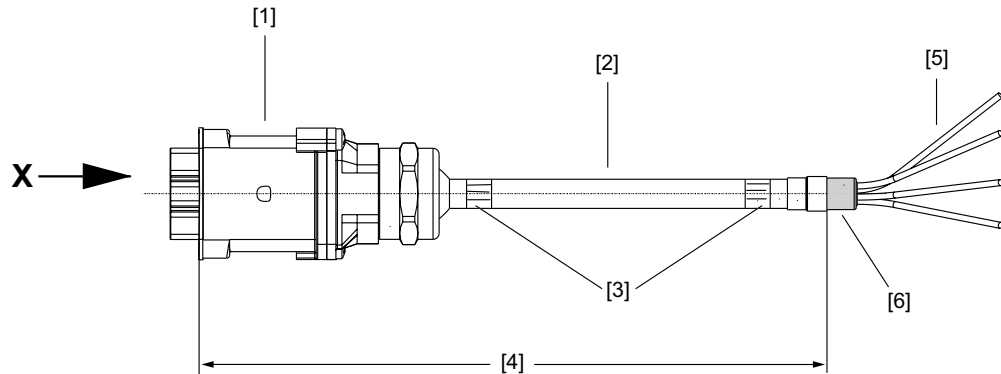

574170891

- [1] Connector: Amphenol
- [2] SEW-EURODRIVE logo printed on cable
- [3] Nameplate
- [4] Cable length ≤ 10 m: Tolerance +200 mm
Cable length ≥ 10 m: Tolerance +2%
Permitted line length according to the technical documents.
- [5] Prefabricated cable end for inverter
Required loose parts are supplied with the cable.
- [6] Shielding 20 mm, pulled back approximately + 5 mm

Motor side

The cables on the motor end have a 6-pin EMC Amphenol plug connector and socket contacts.

The shield is connected in the connector housing according to EMC requirements. All plug connectors seal the plug on the cable end with a lamellar seal and ensure cable relief according to EN 61884.

Inverter side

The individual cable cores of the motor and brakemotor cables are exposed and the shield is prepared for connection in the control cabinet. The cable for the inverter end has yet to be assembled. The loose parts required are supplied with the cable in a separate bag.

Loose parts

The following loose parts are supplied in accordance with the core cross sections for connection to the power terminals on the inverter:

Bag no.	Content
1	4 x conductor end sleeves 1.5 mm ² , insulated 4 x M6 U-shaped cable lugs 1.5 mm ²
2	4 x conductor end sleeves 2.5 mm ² , insulated 4 x M6 U-shaped cable lugs 2.5 mm ²
3	4 x conductor end sleeves 4 mm ² , insulated 4 x M6 U-shaped cable lugs 4 mm ² 4 x M10 U-shaped cable lugs 4 mm ²
4	4 x M6 U-shaped cable lugs 6 mm ² 4 x M10 U-shaped cable lugs 6 mm ²
5	4 x M6 U-shaped cable lugs 10 mm ² 4 x M10 ring-type cable lugs 10 mm ²



5.6.2 Motor cable for CFM motors

CFM motor cable:

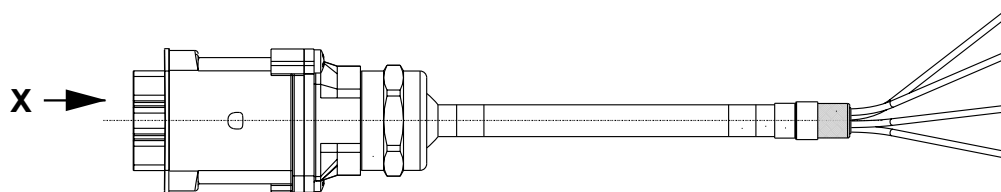

413946763

Types of CFM motor cables

The cables are equipped with a connector for motor connection and conductor end sleeves for inverter connection.

Plug connector type	Number of cores and cable cross section	Installation	Part number
SM51/SM61	4 × 1.5 mm ² (AWG 16)	Fixed installation	0199 1795
SM52/SM62	4 × 2.5 mm ² (AWG 14)		0199 1817
SM54/SM64	4 × 4 mm ² (AWG 12)		0199 1833
SM56/SM66	4 × 6 mm ² (AWG 10)		0199 185X
SM59/SM69	4 × 10 mm ² (AWG 8)		0199 1876
SM51/SM61	4 × 1.5 mm ² (AWG 16)	Cable carrier installation	1333 1140
SM52/SM62	4 × 2.5 mm ² (AWG 14)		1333 1159
SM54/SM64	4 × 4 mm ² (AWG 12)		0199 1841
SM56/SM66	4 × 6 mm ² (AWG 10)		0199 1868
SM59/SM69	4 × 10 mm ² (AWG 8)		0199 1884

CFM motor cable – pin assignment

Plug connector View X	Pin	Cable core color	Assigned	Pin	Extra
C148U connector with socket contacts	U1	(BK/WH) Black with white lettering U, V, W	U	Cut-off, length about 250 mm	
	V1		V		
	W1		W		
	PE	(GN/YE) Green/yellow	(protective earth)	With Phoenix plug connector GMVSTBW 2.5/3 ST	Bag of loose parts



Electrical Installation

Power cables for CFM motors

CFM motor cable – alternative plug connector

Plug connectors for power supply with socket contacts (complete):

Plug connector type	Cross sections	Installation	Part number
SM51/SM61	4 × 1.5 mm ² (AWG 16)	Fixed installation / cable carrier installation	0199 1353
SM52/SM62	4 × 2.5 mm ² (AWG 14)		0199 1361
SM54/SM64	4 × 4 mm ² (AWG 12)		0199 137X
SM56/SM66	4 × 6 mm ² (AWG 10)		0199 1388
SM59/SM69	4 × 10 mm ² (AWG 8)		0199 1396



5.6.3 CFM motor cable – extension cable

CFM motor extension cable:

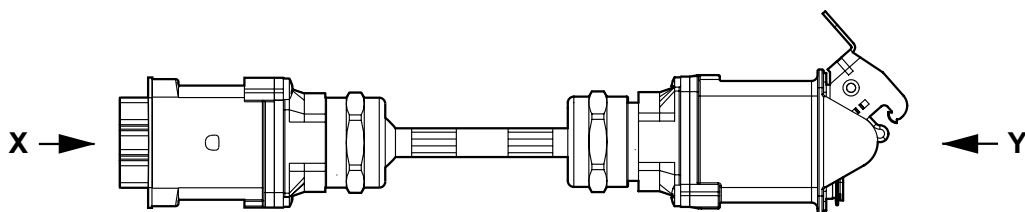

413950219

CFM motor cable – types of extension cables

The cables are equipped with a plug and adapter for extending the CFM motor cable.

Plug connector type	Number of cores and cable cross section	Installation	Part number
SM51/SM61	4 × 1.5 mm ² (AWG 16)	Fixed installation	0199 5499
SM52/SM62	4 × 2.5 mm ² (AWG 14)		0199 5510
SM54/SM64	4 × 4 mm ² (AWG 12)		0199 5537
SM56/SM66	4 × 6 mm ² (AWG 10)		0199 5553
SM59/SM69	4 × 10 mm ² (AWG 8)		0199 557X
SM51/SM61	4 × 1.5 mm ² (AWG 16)	Cable carrier installation	1333 1183
SM52/SM62	4 × 2.5 mm ² (AWG 14)		1333 1191
SM54/SM64	4 × 4 mm ² (AWG 12)		0199 5545
SM56/SM66	4 × 6 mm ² (AWG 10)		0199 5561
SM59/SM69	4 × 10 mm ² (AWG 8)		0199 5588

CFM motor extension cable – pin assignment

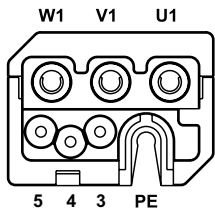
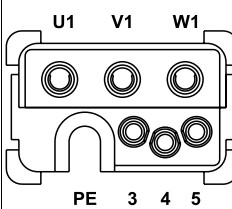
Plug connector View X	Pin	Core identification	Pin	Plug connector View Y
C148U connector with socket contacts	U1	(BK/WH) Black with white lettering U, V, W	U1	C148U adapter with pin contacts
	V1		V1	
	W1		W1	
	PE	(GN/YE) Green/yellow	PE	

The motor extension cable has the same pin assignment as all other contacts.



Electrical Installation

Power cables for CFM motors

Extension cable for CFM motor cable – alternative plug connector

Plug connector for power supply with pins (complete).

Plug connector type	Cross sections	Installation	Part number
SM51/SM61	4 × 1.5 mm ² (AWG 16)	Fixed installation / cable carrier installation	0199 5642
SM52/SM62	4 × 2.5 mm ² (AWG 14)		0199 5650
SM54/SM64	4 × 4 mm ² (AWG 12)		0199 5669
SM56/SM66	4 × 6 mm ² (AWG 10)		0199 5677
SM59/SM69	4 × 10 mm ² (AWG 8)		0199 5685



5.6.4 Brakemotor cable for CFM motors

CFM brakemotor cable:

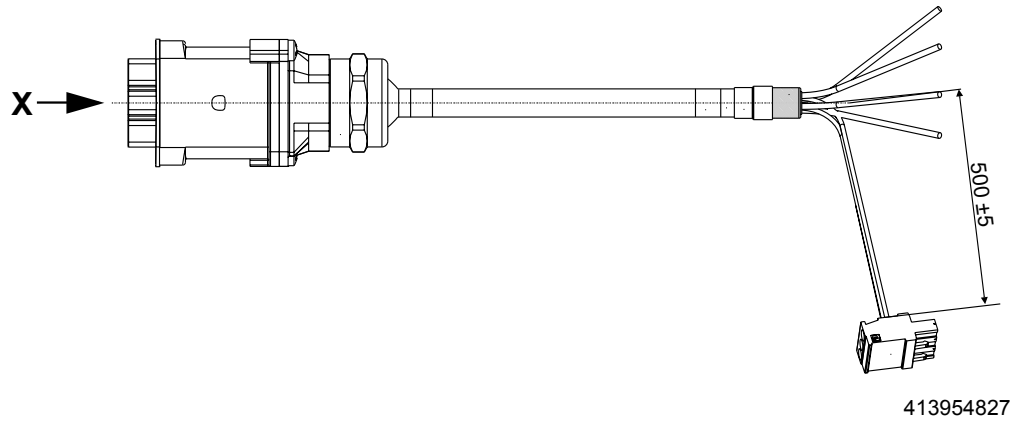

CFM brakemotor cable types

Plug connector type, complete	Number of cores and cable cross section	Installation	Part number
SB51/SB61	4 × 1.5 mm ² (AWG 16) + 3 × 1.0 mm ² (AWG 18)	Fixed installation	0199 1892
SB52/SB62	4 × 2.5 mm ² (AWG 14) + 3 × 1.0 mm ² (AWG 18)		0199 1914
SB54/SB64	4 × 4 mm ² (AWG 12) + 3 × 1.0 mm ² (AWG 18)		0199 1930
SB56/SB66	4 × 6 mm ² (AWG 10) + 3 × 1.5 mm ² (AWG 16)		0199 1957
SB59/SB69	4 × 10 mm ² (AWG 8) + 3 × 1.5 mm ² (AWG 16)		0199 1973
SB51/SB61	4 × 1.5 mm ² (AWG 16) + 3 × 1.0 mm ² (AWG 18)	Cable carrier installation	1333 1167
SB52/SB62	4 × 2.5 mm ² (AWG 14) + 3 × 1.0 mm ² (AWG 18)		1333 1175
SB54/SB64	4 × 4 mm ² (AWG 12) + 3 × 1.0 mm ² (AWG 18)		0199 1949
SB56/SB66	4 × 6 mm ² (AWG 10) + 3 × 1.5 mm ² (AWG 16)		0199 1965
SB59/SB69	4 × 10 mm ² (AWG 8) + 3 × 1.5 mm ² (AWG 16)		0199 1981



CFM brakemotor cable – pin assignment

The brakemotor cable is prefabricated for the following brake resistors:

- BME
- BMP
- BMH
- BMK
- BMV

For the BSG control unit, the customers have to assemble the cable themselves.

Plug connector View X	Pin	Core identifica- tion	Assigned	Contact type	Extra
C148U connector with socket contacts	U1	Black with white lettering U, V, W (BK/WH)	U	Cut-off, length about 250 mm	Bag of loose parts
	V1		V		
	W1		W		
	PE	Green/yellow (GN/YE)	(protec- tive earth)	With Phoenix plug connector GMVSTBW 2,5/3ST	
	3	Black with white lettering 1, 2, 3 (BK/WH)	1		
	4		2		
	5		3		

CFM brakemotor cable – alternative plug connector

Plug connectors for power supply with socket contacts (complete).

Type	Cross sections	Installation	Part number
SB51/SB61	4 × 1.5 mm ² (AWG 16) + 3 × 1.0 mm ² (AWG 18)	Fixed installation / cable carrier installation	0199 1426
SB52/SB62	4 × 2.5 mm ² (AWG 14) + 3 × 1.0 mm ² (AWG 18)		0199 1434
SB54/SB64	4 × 4 mm ² (AWG 12) + 3 × 1.0 mm ² (AWG 18)		0199 1442
SB56/SB66	4 × 6 mm ² (AWG 10) + 3 × 1.5 mm ² (AWG 16)		0199 1450
SB59/SB69	4 × 10 mm ² (AWG 8) + 3 × 1.5 mm ² (AWG 16)		0199 1469



5.6.5 Brakemotor extension cable for CFM motors

CFM brakemotor extension cable

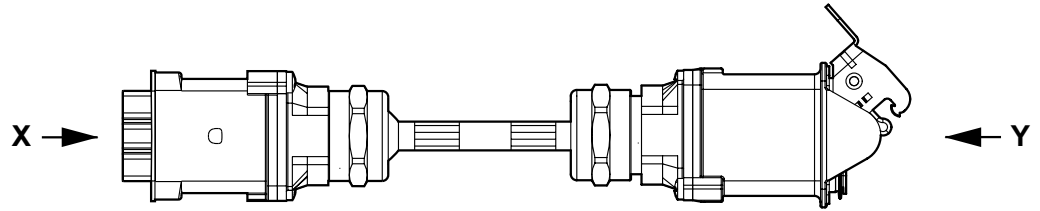

413950219

Types of brakemotor extension cables for CFM motors

Plug connector type, complete	Number of cores and cable cross section	Installation	Part number
SB51/SB61	4 × 1.5 mm ² (AWG 16) + 3 × 1.0 mm ² (AWG 18)	Fixed installation	0199 199X
SB52/SB62	4 × 2.5 mm ² (AWG 14) + 3 × 1.0 mm ² (AWG 18)		0199 2015
SB54/SB64	4 × 4 mm ² (AWG 12) + 3 × 1.0 mm ² (AWG 18)		0199 2031
SB56/SB66	4 × 6 mm ² (AWG 10) + 3 × 1.5 mm ² (AWG 16)		0199 2058
SB59/SB69	4 × 10 mm ² (AWG 8) + 3 × 1.5 mm ² (AWG 16)		0199 2074
SB51/SB61	4 × 1.5 mm ² (AWG 16) + 3 × 1.0 mm ² (AWG 18)	Cable carrier installation	1333 1205
SB52/SB62	4 × 2.5 mm ² (AWG 14) + 3 × 1.0 mm ² (AWG 18)		1333 1213
SB54/SB64	4 × 4 mm ² (AWG 12) + 3 × 1.0 mm ² (AWG 18)		0199 204X
SB56/SB66	4 × 6 mm ² (AWG 10) + 3 × 1.5 mm ² (AWG 16)		0199 2066
SB59/SB69	4 × 10 mm ² (AWG 8) + 3 × 1.5 mm ² (AWG 16)		0199 2082

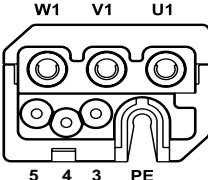
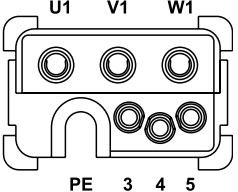

CFM brakemotor extension cable – pin assignment

Plug connector View X	Pin	Core identification	Pin	Plug connectors View Y
C148U connector with socket contacts	U1	(BK/WH) Black with white lettering U, V, W	U1	C148U adapter with pin contacts
	V1		V1	
	W1		W1	
	PE	(GN/YE) Green/yellow	PE	
	3	(BK/WH) Black with white lettering 1, 2, 3	3	
	4		4	
	5		5	

The brake motor extension cable has the same pin assignment as all other contacts.

CFM brakemotor extension cable – alternative plug connector

Plug connector for power supply with pins (complete).

Type	Cross sections	Installation	Part number
SB51/SB61	4 × 1.5 mm ² (AWG 16) + 3 × 1.0 mm ² (AWG 18)	Fixed installation / cable carrier installation	0199 1477
SB52/SB62	4 × 2.5 mm ² (AWG 14) + 3 × 1.0 mm ² (AWG 18)		0199 1485
SB54/SB64	4 × 4 mm ² (AWG 12) + 3 × 1.0 mm ² (AWG 18)		0199 1493
SB56/SB66	4 × 6 mm ² (AWG 10) + 3 × 1.5 mm ² (AWG 16)		0199 1507
SB59/SB69	4 × 10 mm ² (AWG 8) + 3 × 1.5 mm ² (AWG 16)		0199 1515



5.7 Feedback cable for resolver

5.7.1 Structure of the feed back cable for resolver

Plug connector – resolver:

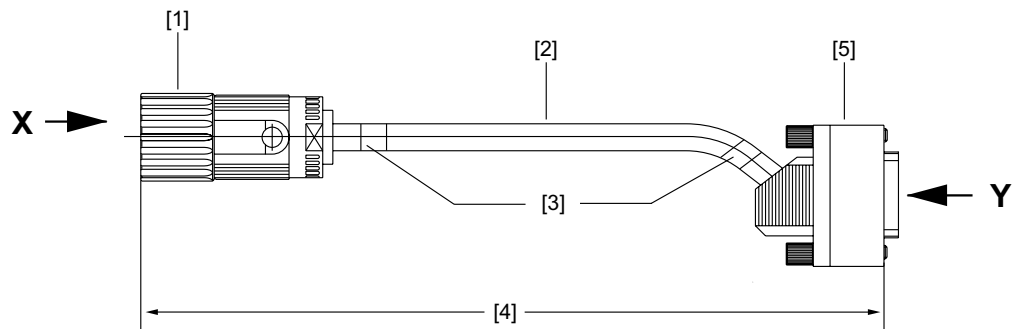

413963531

- [1] Connector: Intercontec ASTA
- [2] Printed on connector: SEW-EURODRIVE
- [3] Nameplate
- [4] Cable length ≤ 10 m: Tolerance +200 mm
Cable length ≥ 10 m: Tolerance +2%
Permitted line length according to the technical documents.
- [5] D-sub plug

Motor side

A 12-pin EMC signal plug connector from Intercontec with socket contacts is used on the motor end for RH.M / RH.L / AS1H / ES1H. The shield is connected in the connector housing according to EMC requirements. All plug connectors seal the plug on the cable end with a lamellar seal.

A feedback cable is alternatively available for the corresponding terminal box. The individual cable strands are exposed and prepared for connection to the terminal box.

Inverter side

A commercial sub-D EMC connector with pin contacts is used on the inverter end. A 9-pin or 15-pin connector is used adjusted to the inverter.

Hybrid cables

The outer cable sheath on the motor and inverter end bears a nameplate with part number and logo of the prefabricated cable manufacturer. The ordered length and permitted tolerance are interrelated as follows:

- Cable length ≤ 10 m: Tolerance +200 mm.
- Cable length ≥ 10 m: Tolerance +2 %.

Make sure you provide for an EMC-compliant environment.



TIP

When configuring the maximum cable length, refer to the data specified in the inverter system manual.



5.7.2 RH.M/RH.L resolver cable plug connector for MOVIDRIVE® MDX61B

RH.M/RH.L resolver cable plug connector for MOVIDRIVE® MDX61B:

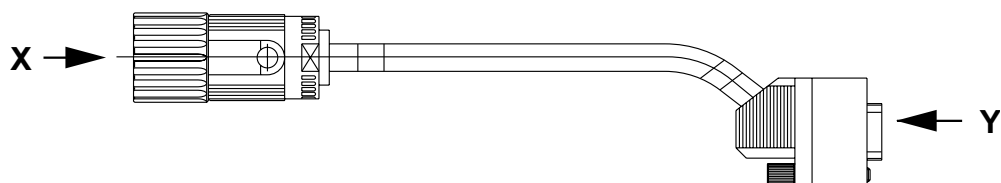

413965067

RH.M/RH.L resolver cable plug connector for MOVIDRIVE® MDX61B – types

Type	Cross section	Installation	Part number
DFS/CFM	5 × 2 × 0.25 mm ² (AWG 24)	Fixed installation	0199 4875
DFS/CFM		Cable carrier installation	0199 3194

RH.M/RH.L resolver cable plug connector for MOVIDRIVE® MDX61B – pin assignment

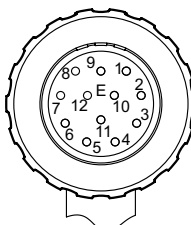
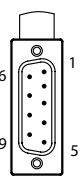
RH1M resolver cable – pin assignment						
Motor connection side		Description	Cable core color	Description	MOVIDRIVE® MDX61B connection	
Plug connector View X	Contact no.				Contact no.	Plug connector View Y
ASTA 021 FR 0198 6732 12-pole with socket contacts 	1	R1 (reference +)	Pink (PK)	R1 (reference +)	3	D-sub 9-pole 
	2	R2 (reference -)	Gray (GY)	R2 (reference -)	8	
	3	S1 (cosine +)	Red (RD)	S1 (cosine +)	2	
	4	S3 (cosine -)	Blue (BU)	S3 (cosine -)	7	
	5	S2 (sine +)	Yellow (YE)	S2 (sine +)	1	
	6	S4 (sine -)	Green (GN)	S4 (sine -)	6	
	7	n. c.	–	–	–	
	8	n. c.	–	–	–	
	9	TF/KTY +	Brown (BN) / violet (VT) ¹⁾	TF/KTY +	9	
	10	TF/KTY–	White (WH) / black (BK) ¹⁾	TF/KTY–	5	
	11	n. c.	–	–	–	
	12	n. c.	–	n. c.	4	

1) Double assignment to increase cross section



5.7.3 RH.M/RH.L resolver cable plug connector for MOVIAXIS® MX

RH.M/RH.L resolver cable for MOVIAXIS® MX:

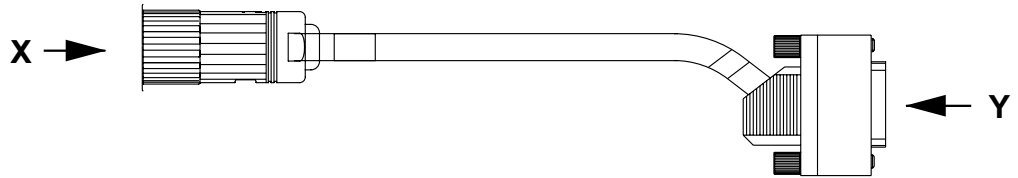

413970059

RH.M/RH.L resolver cable for MOVIAXIS® MX – types

Type	Cross section	Installation	Part number
DFS/CFM	5 × 2 × 0.25 mm ² (AWG 24)	Fixed installation	1332 7429
DFS/CFM		Cable carrier installation	1332 7437

RH.M/RH.L resolver cable for MOVIAXIS® MX – pin assignment

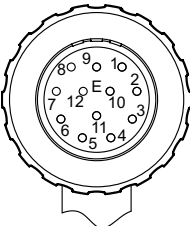
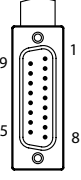
RH1M resolver cable – pin assignment						
Motor connection side					Connection MOVIAXIS® MX	
Plug connector View X	Contact no.	Description	Cable core color	Description	Contact no.	Plug connector View Y
ASTA 021 FR 0198 6732 12-pole with socket contacts 	1	R1 (reference +)	Pink (PK)	R1 (reference +)	5	D-sub 15-pole 
	2	R2 (reference -)	Gray (GY)	R2 (reference -)	13	
	3	S1 (cosine +)	Red (RD)	S1 (cosine +)	2	
	4	S3 (cosine -)	Blue (BU)	S3 (cosine -)	10	
	5	S2 (sine +)	Yellow (YE)	S2 (sine +)	1	
	6	S4 (sine -)	Green (GN)	S4 (sine -)	9	
	7	n. c.	–	n. c.	3	
	8	n. c.	–	n. c.	4	
	9	TF/KTY +	Brown (BN) / violet (VT) ¹⁾	TF/KTY +	14	
	10	TF/KTY–	White (WH) / black (BK) ¹⁾	TF/KTY–	6	
	11	n. c.	–	n. c.	7	
	12	n. c.	–	n. c.	8	
	–	–	–	n. c.	11	
	–	–	–	n. c.	12	
	–	–	–	n. c.	15	

1) Double assignment to increase cross section

All connectors are shown with view onto the pins.



5.7.4 RH.M/RH.L resolver extension cable

RH.M/RH.L resolver extension cable:

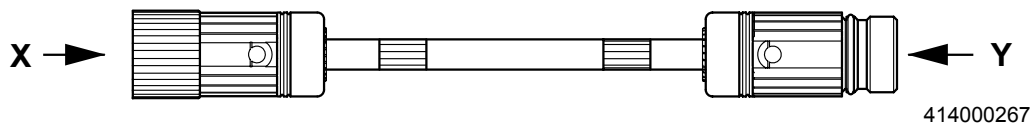

RH.M/RH.L resolver extension cable – types

Type	Cross section	Installation	Part number
DFS/CFM	5 × 2 × 0.25 mm ² (AWG 24)	Fixed installation	0199 5421
DFS/CFM		Cable carrier installation	0199 5413

RH.M/RH.L resolver extension cable – pin assignment

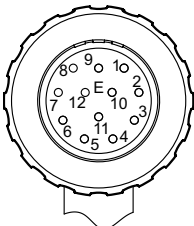
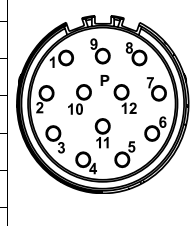
Pin assignment of extension cable for RH.M resolver						
Plug connector View X	Contact no.	Description	Cable core color	Description	Contact no.	Plug connector View Y
ASTA 021 FR 0198 6732 12-pole with socket contacts 	1	R1 (reference +)	Pink (PK)	R1 (reference +)	1	AKUA 020 MR 0199 6479 12-pin with pin contacts 
	2	R1 (reference -)	Gray (GY)	R1 (reference -)	2	
	3	S1 (cosine +)	Red (RD)	S1 (cosine +)	3	
	4	S3 (cosine -)	Blue (BU)	S3 (cosine -)	4	
	5	S2 (sine +)	Yellow (YE)	S2 (sine +)	5	
	6	S4 (sine -)	Green (GN)	S4 (sine -)	6	
	7	n. c.	–	n. c.	7	
	8	n. c.	–	n. c.	8	
	9	TF/KTY +	Brown (BN) / violet (VT) ¹⁾	TF/KTY +	9	
	10	TF/KTY–	White (WH) / black (BK) ¹⁾	TF/KTY–	10	
	11	n. c.	–	n. c.	11	
	12	n. c.	–	n. c.	12	

1) Double assignment to increase cross section

The extension cable has the same pin assignment as all other contacts.

5.7.5 RH.M/RH.L resolver cable – alternative plug connector

Signal plug connector with socket contacts (complete)

Type	Cross section	Installation	Part number
RH.M/RH.L	6 × 2 × 0.06 ... 1 mm ² (AWG 29 ... AWG 18)	Fixed installation / cable carrier installation	0198 6732

Signal plug connector with pins (complete)

Type	Cross section	Installation	Part number
RH.M/RH.L	6 × 2 × 0.06 ... 1 mm ² (AWG 29 ... AWG 18)	Fixed installation / cable carrier installation	0199 6479



5.7.6 RH.M/RH.L resolver cable – DFS/CFM terminal box for MOVIDRIVE® MDX61B with DC 5 V supply

Resolver cable for MOVIDRIVE® MDX61B:

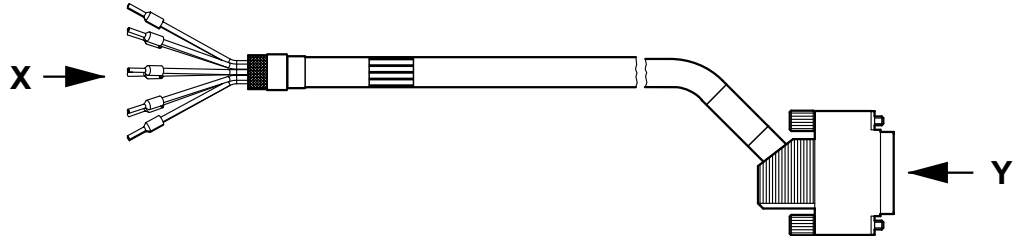

475439755

Resolver cable for MOVIDRIVE® MDX61B – types

Type	Cross section	Installation	Part number
DFS	5 × 2 × 0.25 mm ² (AWG 24)	Fixed installation	1332 8174
DFS		Cable carrier installation	1332 8441
CFM		Fixed installation	0199 5898
CFM		Cable carrier installation	0199 5901

RH.M/RH.L resolver cable – pin assignment

Terminal box/RH1M resolver connection for DFS/CFM motors						
Motor connection side					MOVIDRIVE® MDX61B connection	
Terminal strip View X	Contact no.	Description	Cable core color	Description	Contact no.	Plug connector View Y
	1	R1 (reference +)	Pink (PK)	R1 (reference +)	3	
	2	R2 (reference -)	Gray (GY)	R2 (reference -)	8	
	3	S1 (cosine +)	Red (RD)	S1 (cosine +)	2	
	4	S3 (cosine -)	Blue (BU)	S3 (cosine -)	7	
	5	S2 (sine +)	Yellow (YE)	S2 (sine +)	1	
	6	S4 (sine -)	Green (GN)	S4 (sine -)	6	
	7	n.c.	–	n.c.	4	
	8	n.c.	–	–	–	
	9	TF/KTY +	Brown (BN) / violet (VT) ¹⁾	TF/KTY +	9	
	10	TF/KTY–	White (WH) / black (BK) ¹⁾	TF/KTY–	5	

1) Double assignment to increase cross section



5.7.7 RH.M/RH.L resolver cable – DFS/CFM terminal box for MOVIAXIS® MX

Resolver cable for MOVIAXIS® MX:

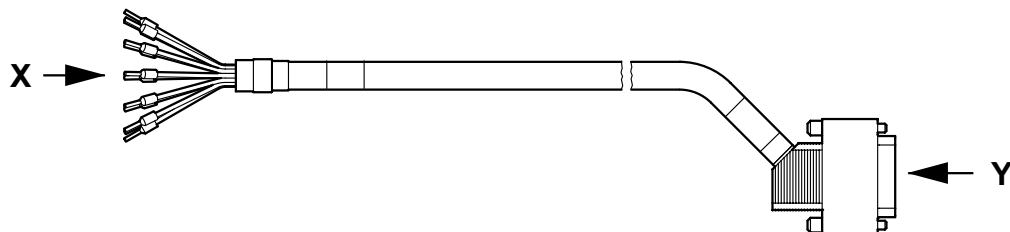

475441291

Resolver cable for MOVIAXIS MX® – types

Type	Cross section	Installation	Part number
DFS	5 × 2 × 0.25 mm ² (AWG 24)	Fixed installation	1332 7445
DFS		Cable carrier installation	1332 7453
CFM		Fixed installation	1332 7623
CFM		Cable carrier installation	1332 7631

RH.M / RH.L resolver cable – pin assignment

MOVIAXIS® MX with DFS/CFM motors – RH.M / RH.L resolver/terminal box connection						
Motor connection side				Connection MOVIAXIS® MX		
Terminal strip View X	Contact no.	Description	Cable core color	Description	Contact no.	Plug connector View Y
	1	R1 (reference +)	Pink (PK)	R1 (reference +)	5	
	2	R2 (reference -)	Gray (GY)	R2 (reference -)	13	
	3	S1 (cosine +)	Red (RD)	S1 (cosine +)	2	
	4	S3 (cosine -)	Blue (BU)	S3 (cosine -)	10	
	5	S2 (sine +)	Yellow (YE)	S2 (sine +)	1	
	6	S4 (sine -)	Green (GN)	S4 (sine -)	9	
	7	n. c	–	n. c	3	
	8	n. c	–	n. c	4	
	9	TF/KTY +	Brown (BN) / violet (VT) ¹⁾	TF/KTY +	14	
	10	TF/KTY–	White (WH) / black (BK) ¹⁾	TF/KTY–	6	
	11	–	–	n. c	7	
	12	–	–	n. c	8	
	13	–	–	n. c	11	
	14	–	–	n. c	12	
	15	–	–	n. c	15	

1) Double assignment to increase cross section



5.8 Feedback cable for HIPERFACE® encoders

5.8.1 Feedback cable for HIPERFACE® encoders – structure

Plug connector – resolver:



- [1] Connector: Intercontec ASTA
- [2] Printed on connector: SEW-EURODRIVE
- [3] Nameplate
- [4] Cable length \leq 10 m: Tolerance +200 mm
Cable length \geq 10 m: Tolerance +2%
Permitted line length according to the technical documents.
- [5] D-sub plug

Motor side

A 12-pin EMC signal plug connector from Intercontec with socket contacts is used on the motor end for RH.M / RH.L / AS1H / ES1H. The shield is connected in the connector housing according to EMC requirements. All plug connectors seal the plug on the cable end with a lamellar seal.

A feedback cable is alternatively available for the corresponding terminal box. The individual cable strands are exposed and prepared for connection to the terminal box.

Inverter side

A commercial D-sub EMC connector with pin contacts is used on the inverter end. A 9-pin or 15-pin connector is used adjusted to the inverter.

Hybrid cables

The outer cable sheath on the motor and inverter end bears a nameplate with part number and logo of the prefabricated cable manufacturer. The ordered length and permitted tolerance are interrelated as follows:

- Cable length \leq 10 m: Tolerance +200 mm.
- Cable length \geq 10 m: Tolerance +2%.

Make sure you provide for an EMC-compliant environment.

	TIP
	When configuring the maximum cable length, refer to the data specified in the inverter system manual.



Electrical Installation

Feedback cable for HIPERFACE® encoders

5.8.2 HIPERFACE® encoder cable for MOVIDRIVE® MDX61B and MOVIAXIS® MX

HIPERFACE® encoder cable for MOVIDRIVE® MDX61B and MOVIAXIS® MX:

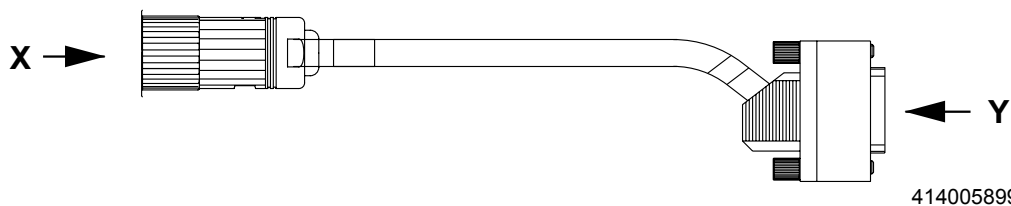

414005899

HIPERFACE® encoder cable for MOVIDRIVE® MDX61B and MOVIAXIS® MX – types

Type	Cross section	Installation	Part number
DFS/CFM	6 × 2 × 0.25 mm ² (AWG 24)	Fixed installation	1332 4535
DFS/CFM		Cable carrier installation	1332 4551

HIPERFACE® cable for AS1H / ES1H / AV1H encoders – pin assignment

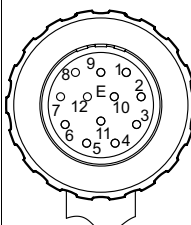
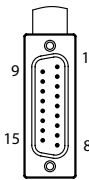
HIPERFACE® cable for AS1H / ES1H / AV1H encoders – pin assignment						
Motor connection side				Connection MOVIDRIVE® MDX61B MOVIAXIS® MX		
Plug connector View X	Pin no.	Description	Cable core color	Description	Pin no.	Plug connector View Y
ASTA 021 FR 0198 6732 12-pole with socket contacts 	1	n. c.	n. c.	n. c.	3	D-sub 15-pole 
	2	n. c.	n. c.	n. c.	5	
	3	S1 (cosine +)	Red (RD)	S1 (cosine +)	1	
	4	S3 (cosine -)	Blue (BU)	S3 (cosine -)	9	
	5	S2 (sine +)	Yellow (YE)	S2 (sine +)	2	
	6	S4 (sine -)	Green (GN)	S4 (sine -)	10	
	7	DATA -	Violet (VT)	DATA -	12	
	8	DATA +	Black (BK)	DATA +	4	
	9	TF/KTY +	Brown (BN)	TF/KTY +	14	
	10	TF/KTY-	White (WH)	TF/KTY-	6	
	11	GND	Grey/pink (GY-PK) / Pink (PK) ¹⁾	GND	8	
	12	U _s	Red/blue (RD-BU) / gray (GY) ¹⁾	U _s	15	
	-	-	-	n. c.	7	
-	-	-	n. c.	11		
-	-	-	n. c.	13		

1) Double assignment to increase cross section



5.8.3 Extension cable for AS1H / ES1H / AV1H HIPERFACE® encoders

Extension cable for AS1H / ES1H / AV1H HIPERFACE® encoders:

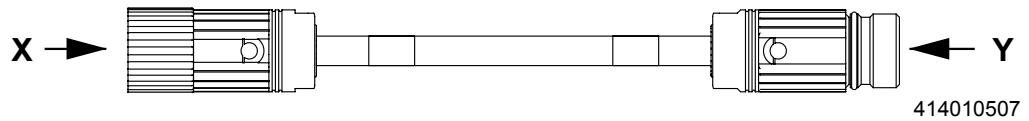

Extension cable for AS1H / ES1H / AV1H HIPERFACE® encoders – types

Type	Cross section	Installation	Part number
DFS/CFM	6 × 2 × 0.25 mm ² (AWG 24)	Fixed installation	0199 5391
DFS/CFM		Cable carrier installation	0199 5405

Extension cable for AS1H / ES1H / AV1H HIPERFACE® encoders – pin assignment

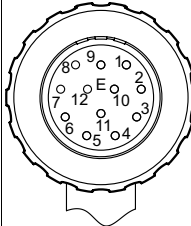
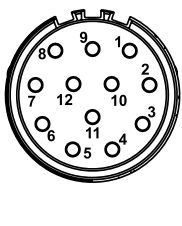
Extension cable for AS1H / ES1H / AV1H HIPERFACE® encoders – pin assignment						
Plug connector View X	Pin no.	Description	Cable core color	Description	Pin no.	Plug connector View Y
ASTA 021 FR 0198 6732 12-pole with socket contacts 	1	n. c.	–	n. c.	1	AKUA 020 MR 0199 6479 12-pin with pin contacts 
	2	n. c.	–	n. c.	2	
	3	S1 (cosine +)	Red (RD)	S1 (cosine +)	3	
	4	S3 (cosine -)	Blue (BU)	S3 (cosine -)	4	
	5	S2 (sine +)	Yellow (YE)	S2 (sine +)	5	
	6	S4 (sine -)	Green (GN)	S4 (sine -)	6	
	7	DATA –	Violet (VT)	DATA –	7	
	8	DATA +	Black (BK)	DATA +	8	
	9	TF/KTY +	Brown (BN)	TF/KTY +	9	
	10	TF/KTY–	White (WH)	TF/KTY–	10	
	11	GND	Gray/pink (GY/PK) Pink (PK) ¹⁾	GND	11	
	12	U _s	Red/blue (RD-BU) / gray (GY) ¹⁾	U _s	12	

1) Double assignment to increase cross section

The extension cable has the same pin assignment as all other contacts.



5.8.4 Alternative plug connector cable for AS1H / ES1H / AV1H HIPERFACE® encoders

Signal plug connector with socket contacts (complete)

Type	Cross sections that can be connected	Installation	Part number
AS1H	6 × 2 × 0.06 ... 1 mm ² (AWG 29 ... AWG 18)	Fixed installation / cable carrier installation	0198 6732
ES1H			
AV1H			

Signal plug connector with pins (complete)

Type	Cross sections that can be connected	Installation	Part number
AS1H	6 × 2 × 0.06 ... 1 mm ² (AWG 29 ... AWG 18)	Fixed installation / cable carrier installation	0199 6479
ES1H			
AV1H			



5.8.5 HIPERFACE® encoder cable CFM terminal box CFM for MOVIAXIS® MX, MOVIDRIVE® MDX61B

HIPERFACE® encoder cable for CFM motors:

The following figure shows the HIPERFACE® encoder cable with terminal box connection for CFM motors.

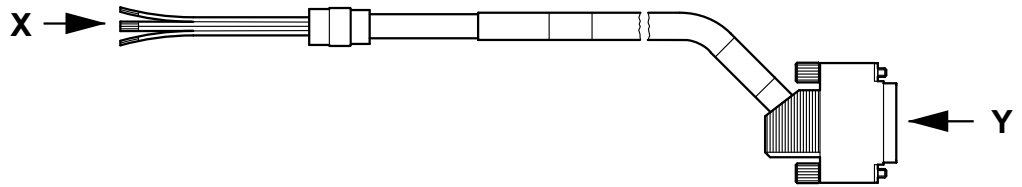

476134411

HIPERFACE® encoder cable for CFM motors – types

Type	Cross section	Installation	Part number
CFM	6 × 2 × 0.25 mm ² (AWG 24)	Fixed installation	1332 4578
CFM		Cable carrier installation	1332 4543

Pin assignment HIPERFACE® encoder cable AS1H/ES1H

HIPERFACE® cable to terminal box MOVIAXIS® MX, MOVIDRIVE® MDX61B with CFM motors						
Motor connection side				Connection MOVIAXIS® MX MOVIDRIVE® MDX61B		
Terminal strip View X	Pin no.	Description	Cable core color	Description	Pin no.	Plug connector View Y
	6	Data +	Black (BK)	Data +	4	
	5	Data –	Violet (VT)	Data –	12	
	1	S1 (cosine +)	Red (RD)	S1 (cosine +)	1	
	2	S3 (cosine -)	Blue (BU)	S3 (cosine -)	9	
	3	S2 (sine +)	Yellow (YE)	S2 (sine +)	2	
	4	S4 (sine -)	Green (GN)	S4 (sine -)	10	
	7	GND	Gray/pink (GY/PK) Pink (PK) ¹⁾	GND	8	
	8	Us	Red/blue (RD-BU) / gray (GY) ¹⁾	Us	15	
	9	TF/KTY +	Brown (BN)	TF/KTY +	14	
	10	TF/KTY–	White (WH)	TF/KTY–	6	

1) Double assignment to increase cross section



Electrical Installation

Feedback cable for HIPERFACE® encoders

5.8.6 HIPERFACE® encoder cable DFS terminal box CFM for MOVIAXIS® MX, MOVIDRIVE® MDX61B

HIPERFACE® encoder cable for DFS motors:

The following figure shows the HIPERFACE® encoder cable with terminal box connection for DFS motors.

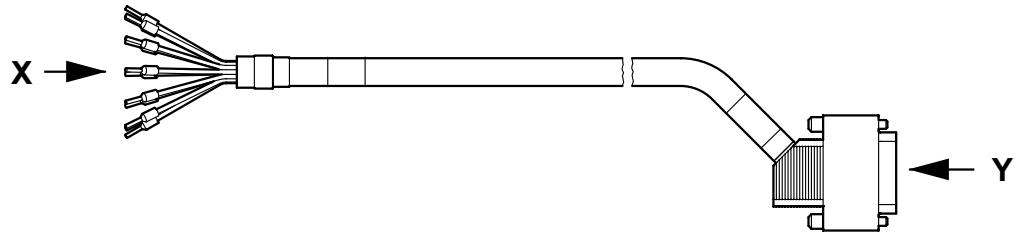

475441291

HIPERFACE® encoder cable for DFS motors – types

Type	Cross section	Installation	Part number
DFS	6 × 2 × 0.25 mm ² (AWG 24)	Fixed installation	1332 7658
DFS		Cable carrier installation	1332 7666

Cable for AS1H / ES1H / AV1H HIPERFACE® encoders – pin assignment

HIPERFACE® cable to terminal box MOVIAXIS® MX, MOVIDRIVE® MDX61B with DFS motors						
Motor connection side				Connection MOVIAXIS® MX MOVIDRIVE® MDX61B		
Terminal strip View X	Pin no.	Description	Cable core color	Description	Pin no.	Plug connector View Y
	6	Data +	Black (BK)	Data +	4	
	5	Data –	Violet (VT)	Data –	12	
	1	S1 (cosine +)	Red (RD)	S1 (cosine +)	1	
	2	S3 (cosine -)	Blue (BU)	S3 (cosine -)	9	
	3	S2 (sine +)	Yellow (YE)	S2 (sine +)	2	
	4	S4 (sine -)	Green (GN)	S4 (sine -)	10	
	7	GND	Gray/pink (GY/PK) Pink (PK) ¹⁾	GND	8	
	8	Us	Red/blue (RD/BU) Gray (GY) ¹⁾	Us	15	
	9	TF/KTY +	Brown (BN)	TF/KTY +	14	
	10	TF/KTY–	White (WH)	TF/KTY–	6	

1) Double assignment to increase cross section



5.8.7 AV1Y / DIP11A/B encoder cable for MOVIDRIVE® MDX61B

AV1Y / DIP11A/B encoder cable:

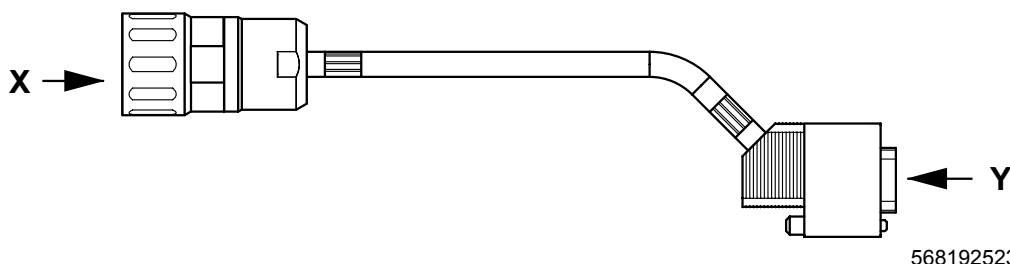



568192523

AV1Y / DIP11A/B encoder cable – types

Type	Cross section	Installation	Part number
DFS/CFM	3 × 2 × 0.25 mm ² (AWG 24)	Fixed installation	0198 9294
DFS/CFM		Cable carrier installation	0198 9308

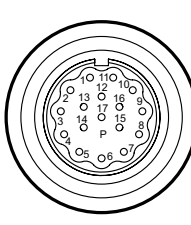
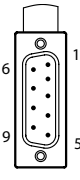
Cable for AV1Y / DIP11A/B encoder – pin assignment

Motor connection side		Pin assignment			MOVIDRIVE® MDX61B connection	
Round connector View X	Pin no.	Description	Cable core color	Description	Pin no.	Plug connector
SPUC 17H FRON 005 0198 8867 17-pole with socket contacts 	1	n. c	–	n. c	–	D-sub 9-pole 
	2	n. c	–	n. c	–	
	3	n. c	–	n. c	–	
	4	n. c	–	n. c	–	
	5	n. c	–	n. c	–	
	6	n. c	–	n. c	–	
	7	UB	White (WH)	UB	9	
	8	T+	Pink (PK)	T+	3	
	9	T–	Gray (GY)	T–	8	
	10	GND	Brown (BN)	GND	5	
	11	n. c	–	n. c	–	
	12	n. c	–	n. c	–	
	13	n. c	–	n. c	–	
	14	D+	Yellow (YE)	D+	1	
	15	n. c	–	n. c	–	
	16	n. c	–	n. c	–	
	17	D–	Green (GN)	D–	6	

	TIP
	SEW-EURODRIVE will provide specifications of the cables with part numbers 0198 9294 and 0198 9308 on request.



Electrical Installation

Feedback cable for HIPERFACE® encoders

5.8.8 AV1Y encoder cable for MOVIDRIVE® MDX61B

AV1Y encoder cable:

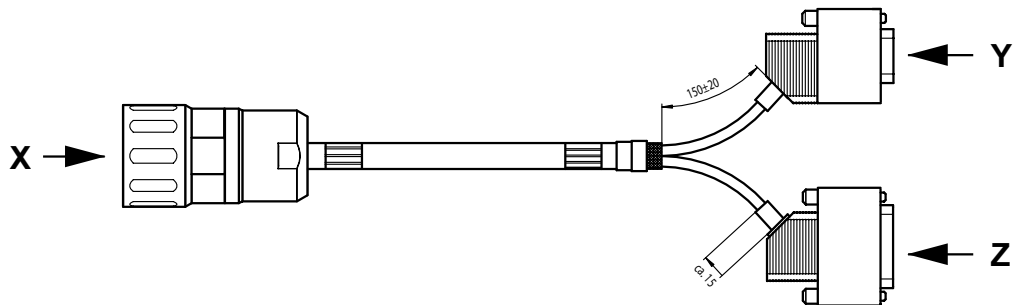

568316555

AV1Y encoder cable – types

Type	Cross section	Installation	Part number
DFS/CFM	5 × 2 × 0.25 mm ² (AWG 24)	Fixed installation	1332 8131
DFS/CFM		Cable carrier installation	1332 8123

Cable for AV1Y encoder – pin assignment

Motor connection side		Pin assignment			MOVIDRIVE® MDX61B connection	
Round connector View X	Pin no.	Description	Cable core color	Description	Pin no.	Plug connector
SPUC 17H FRON 005 0198 8867 17-pole with socket contacts View X	1	n. c	–	n. c	–	D-sub 9-pole View Y
	2	n. c	–	n. c	–	
	3	n. c	–	n. c	–	
	4	n. c	–	n. c	–	
	5	n. c	–	n. c	–	
	6	n. c	–	n. c	–	
	7	UB	White (WH)	UB	9	
	8	T+	Pink (PK)	T+	3	
	9	T–	Gray (GY)	T–	8	
	10	GND	Brown (BN)	GND	5	
	11	n. c	–	n. c	–	
	12	n. c	–	n. c	–	
	13	n. c	–	n. c	–	
	14	D+	Yellow (YE)	D+	1	
	15	n. c	–	n. c	–	
	16	n. c	–	n. c	–	
	17	D–	Green (GN)	D–	6	
12	B	Red (RD)	B	2	D-sub 15-pole View Z	
13	B	Blue (BU)	B	10		
15	A	Yellow (YE)	A	1		
16	A	Green (GN)	A	9		



5.8.9 Extension cable for AV1Y encoder

Extension cable for AV1Y encoder:

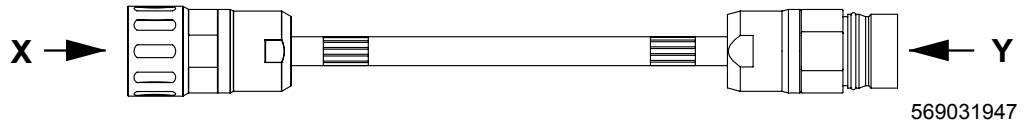

Extension cable for AV1Y encoder – types

Type	Cross section	Installation	Part number
DFS/CFM	5 × 2 × 0.25 mm ² (AWG 24)	Cable carrier installation	0593 9682

Pin assignment of extension cable for AV1Y encoder

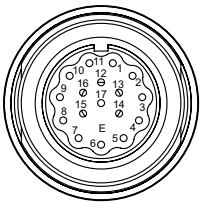
Plug connector View X	Pin no.	Description	Pin assignment			Plug connector View Y
			Cable core color	Description	Pin no.	
Round connector SPUC 17H 0198 8867 17-pole with socket contacts	1	n. c.	–	n. c.	1	Coupling SRUC 17G 0593 4036  17-pin with pin con- tacts
	2	n. c.	–	n. c.	2	
	3	n. c.	–	n. c.	3	
	4	n. c.	–	n. c.	4	
	5	n. c.	–	n. c.	5	
	6	n. c.	–	n. c.	6	
	7	UB	White (WH)	UB	7	
	8	T+	Pink (PK)	T+	8	
	9	T–	Gray (GY)	T–	9	
	10	GND	Brown (BN)	GND	10	
	11	n.c.	–	n.c.	11	
	12	B	Red (RD)	B	12	
	13	\bar{B}	Blue (BU)	\bar{B}	13	
	14	D+	Black (BK)	D+	14	
	15	A	Yellow (YE)	A	15	
	16	\bar{A}	Green (GN)	\bar{A}	16	
	17	D–	Violet (VT)	D–	17	

The extension cable has the same pin assignment as all other contacts.

AV1Y encoder cable – alternative plug connector

Signal plug connector with socket contacts (complete)

Type	Cross section	Installation	Part number
AV1Y	5 × 2 × 0.06 ... 1 mm ² (AWG 29 ... AWG 18)	Cable carrier installation	0198 8867

Signal plug connector with pins (complete)

Type	Cross section	Installation	Part number
AV1Y	5 × 2 × 0.06 ... 1 mm ² (AWG 29 ... AWG 18)	Cable carrier installation	0593 4036



5.9 Forced cooling fan cable

5.9.1 Cable for motors with VR forced cooling fan

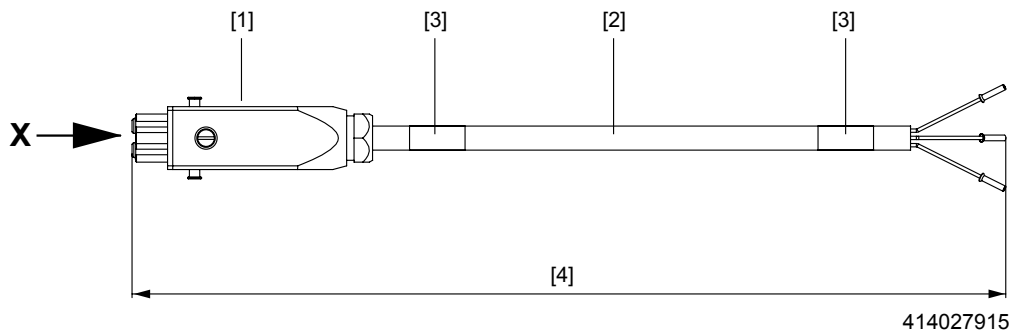

- [1] Connector: STAK 200
- [2] Printed on connector: SEW-EURODRIVE
- [3] Nameplate
- [4] Cable length ≤ 5 m: Tolerance +200 mm
Cable length ≥ 5 m: Tolerance +2%
Permitted line length according to the technical documents.

5.9.2 Cable for VR forced cooling fan – types

Type	Cross section	Installation	Part number
DFS/CFM	3 × 1 mm ² (AWG 18)	Fixed installation	0198 6341
DFS/CFM		Cable carrier installation	0199 560X

5.9.3 Pin assignment of cable for VR forced cooling fan

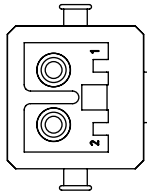
Plug connector STAK 200 200 View X	Pin	Core identification	Assigned	Pin	Connection type
Connector with 2 socket contacts 0198 4985 	1	First digit	24 V +	Cut-off, length ca. 250 mm	Conductor end sleeves
	2	Second digit	0 V		

5.9.4 Cable for VR forced cooling fan – alternative plug connector

Signal plug connector with socket contacts (complete)

Type	Cross sections that can be connected	Installation	Part number
VR	3 × 1 mm ² (AWG 18)	Fixed installation / cable carrier installation	0198 4985



5.9.5 Extension cable for VR forced cooling fan

Extension cable for the VR forced cooling fan:

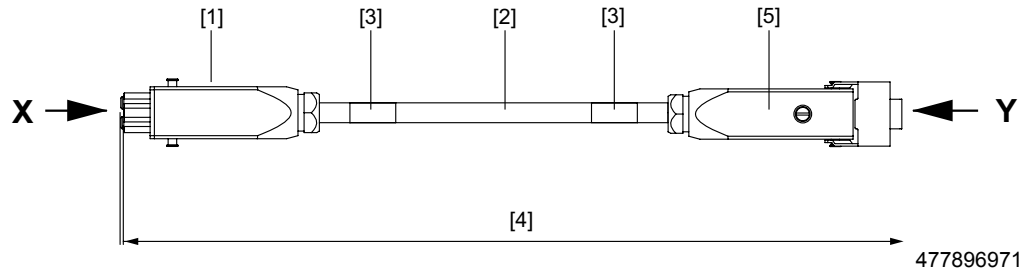

- [1] Socket: STAK 200
- [2] Printed on connector: SEW-EURODRIVE
- [3] Nameplate
- [4] Cable length ≤ 5 m: Tolerance +200 mm
Cable length ≥ 5 m: Tolerance +2%
Permitted line length according to the technical documents.
- [5] Connector: STAS 200

Extension cable for VR forced cooling fan – types

Type	Cross section	Installation	Part number
DFS/CFM	3 × 1 mm ² (AWG 18)	Fixed installation	0199 5618
DFS/CFM		Cable carrier installation	0199 5626

Pin assignment of the extension cable for the VR forced cooling fan

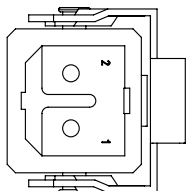
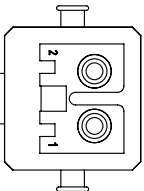
Plug connector STAS 200 View X	Pin	Core identification	Assigned	Pin	Connection type STAK 200 View Y
Connector with 2 pin contacts 0198 5693 	1	First digit	24 V +	1	Connector with 2 socket contacts 0198 4985 
	2	Second digit	0 V	2	

The extension cable has the same pin assignment as all other contacts.

Extension cable for VR forced cooling fan – alternative plug connector

Signal plug connector with pins (complete)

Type	Cross section	Installation	Part number
VR	3 × 1 mm ² (AWG 18)	Fixed installation / cable carrier installation	0198 5693



5.10 Cable specification of motor cables for DFS and CFM motors

5.10.1 Fixed installation of the motor cable

Installation type		fixed				
Cable cross sections		4 x 1.5 mm ² (AWG 16)	4 x 2.5 mm ² (AWG 14)	4 x 4 mm ² (AWG 12)	4 x 6 mm ² (AWG 10)	4 x 10 mm ² (AWG 8)
Manufacturer		HELUKABEL				
Manufacturer designation		LI9YCY				
Operating voltage U ₀ / U AC	[V]	600 / 1000				
Temperature range	[°C]	Fixed installation -40 to +80				
Max. temperature	[°C]	+80				
Min. bending radius	[mm]	45	55	65	73	85
Diameter D	[mm]	9.0 ± 0.2	11 ± 0.2	13 ± 0.2	14.3 ± 0.3	17.0 ± 0.6
Core identification		BK with lettering WH + GN/YE				
Sheath color		Orange, similar to RAL 2003				
Approval(s)		DESINA/VDE/UL				
Capacitance core/shielding	[nF/km]	110	110	118	125	125
Capacitance core/core	[nF/km]	70	70	75	80	80
Halogen-free		No				
silicon-free		yes				
CFC-free		yes				
Inner insulation (core)		PP				
Outer insulation (sheath)		PVC				
Flame-retardant/self-extinguishing		No				
Conductor material		Cu				
Shielding		Tinned Cu				
Weight (cable)	[kg/km]	134	202	262	332	601



5.10.2 Cable carrier installation for motor cables

Installation type		Cable carrier				
Cable cross sections		4 x 1.5 mm ² (AWG 16)	4 x 2.5 mm ² (AWG 14)	4 x 4 mm ² (AWG 12)	4 x 6 mm ² (AWG 10)	4 x 10 mm ² (AWG 8)
Manufacturer		Nexans				
Manufacturer designation		PSL(LC)C11Y-J 4 x ... mm ²		PSL11YC11Y-J 4 x ... mm ²		
Operating voltage U ₀ / U AC	[V]	600 / 1000				
Temperature range	[°C]	-20 to +60				
Max. temperature	[°C]	+90 (on conductor)				
Min. bending radius	[mm]	134	140	135	155	180
Diameter D	[mm]	12.8 + 0.6 / -0.7	15.7 ± 0.3	13.2 ± 0.4	15.4 ± 0.4	17.8 ± 0.5
Maximum acceleration	[m/s ²]	20				
Max. velocity	[m/min]	200 at max. travel distance of 5 m				
Core identification		BK with lettering WH + GN/YE				
Sheath color		Orange similar to RAL 2003				
Approval(s)		DESINA/VDE/UL/cRUus				
Capacitance core/shielding	[nF/km]	95	95	170	170	170
Capacitance core/core	[nF/km]	65	65	95	95	95
Halogen-free		yes				
silicon-free		yes				
CFC-free		yes				
Inner insulation (core)		Polyolefin		TPM		
Outer insulation (sheath)		TPU (PUR)				
Flame-retardant/self-extinguishing		yes				
Conductor material		E-Cu blank				
Shielding		Braided tinned Cu shield (optically covered > 85 %)				
Weight (cable)	[kg/km]	249	373	311	426	644
Min. bending cycles		≥ 5 million				



5.10.3 Fixed installation of the brakemotor cable

Installation type		fixed				
Cable cross sections		4 x 1.5 mm ² (AWG 16) + 3 x 1 mm ² (AWG 18)	4 x 2.5 mm ² (AWG 14) + 3 x 1 mm ² (AWG 18)	4 x 4 mm ² (AWG 12) + 3 x 1 mm ² (AWG 18)	4 x 6 mm ² (AWG 10) + 3 x 1.5 mm ² (AWG 16)	4 x 10 mm ² (AWG 8) + 3 x 1.5 mm ² (AWG 16)
Manufacturer		HELUKABEL				
Manufacturer designation		LI9YCY				
Operating voltage U ₀ / U AC	[V]	600 / 1000				
Temperature range	[°C]	Fixed installation: -40 to +80				
Max. temperature	[°C]	+80				
Min. bending radius	[mm]	60	68	75	85	100
Diameter D	[mm]	11.8 ± 0.4	13.4 ± 0.4	15.0 ± 0.5	17.0 ± 0.6	20.0 ± 1.0
Core identification		BK with lettering WH + GN/YE				
Sheath color		Orange similar to RAL 2003				
Approval(s)		DESINA/VDE/UL				
Capacitance core/shielding	[nF/km]	105	105	110	115	120
Capacitance core/core	[nF/km]	60	60	70	75	78
Halogen-free		No				
silicon-free		yes				
CFC-free		yes				
Inner insulation (core)		PP				
Outer insulation (sheath)		PVC				
Flame-retardant/self-extinguishing		yes				
Conductor material		Cu				
Shielding		Tinned Cu				
Weight (cable)	[kg/km]	229	292	393	542	938



5.10.4 Cable carrier installation for brake motor cables

Installation type		Cable carrier				
Cable cross sections		4 x 1.5 mm² (AWG 16) + 3 x 1 mm² (AWG 18)	4 x 2.5 mm² (AWG 14) + 3 x 1 mm² (AWG 18)	4 x 4 mm² (AWG 12) + 3 x 1 mm² (AWG 18)	4 x 6 mm² (AWG 10) + 3 x 1.5 mm² (AWG 16)	4 x 10 mm² (AWG 8) + 3 x 1.5 mm² (AWG 16)
Manufacturer		Nexans				
Manufacturer designation		PSL(LC)C11Y-J 4x... +3A.../C		PSL11YC11Y-J 4x... +3A.../C		
Operating voltage U ₀ / U AC	[V]	600 / 1000				
Temperature range	[°C]	-20 to +60				
Max. temperature	[°C]	+90 (conductor)				
Min. bending radius	[mm]	159	170	155	175	200
Diameter D	[mm]	15.0 ± 0.9	16.5 ± 0.7	15.3 ± 0.5	17.4 ± 0.5	20.5 ± 0.5
Maximum acceleration	[m/s ²]	20				
Max. velocity	[m/min]	200 at max. travel distance of 5 m				
Core identification		BK with lettering WH + GN/YE				
Sheath color		Orange similar to RAL 2003				
Approval(s)		DESINA/VDE/UL/cRUus				
Capacitance core/shielding	[nF/km]	105	105	170	170	170
Capacitance core/core	[nF/km]	65	65	95	95	95
Halogen-free		yes				
silicon-free		yes				
CFC-free		yes				
Inner insulation (cable)		TPM				
Outer insulation (sheath)		Polyolefin		TPU (PUR)		
Flame-retardant/self-extinguishing		yes				
Conductor material		E-Cu blank				
Shielding		Braided tinned Cu shield (optically covered > 85 %)				
Weight (cable)	[kg/km]	335	433	396	522	730
Min. bending cycles		≥ 5 million				



5.11 Cable specification of feedback cables for DFS and CFM motors

5.11.1 Fixed installation of feedback cables

Installation type		fixed		
Accessory designation		AS1H/ES1H	RH.M/RH.L	VR
Cable cross sections		6 x 2 x 0.25 mm ² (AWG 24)	5 x 2 x 0.25 mm ² (AWG 24)	3 x 1 mm ² (AWG 18)
Manufacturer		HELUKABEL		Lapp
Manufacturer designation		LI9YCY		Öflex 110 Classic
Operating voltage V ₀ / V AC	[V]	230 / 350		300 / 500
Temperature range	[°C]	Fixed installation -40 to +80		-30 to +70
Max. temperature	[°C]	+80		+70
Min. bending radius	[mm]	43	36.5	24
Diameter D	[mm]	8.6 ± 0.2	7.3 ± 0.2	6.0 ± 0.3
Core identification		DIN 47 100		VDE 0293
Sheath color		Green, similar to RAL 6018		Silver gray, RAL 7001
Approval(s)		DESINA/VDE/cRUus		VDE
Capacitance core/shielding	[nF/km]	110		–
Capacitance core/core	[nF/km]	70		–
Halogen-free		No		
silicon-free		yes		
CFC-free		yes		
Inner insulation (core)		PP		PVC
Outer insulation (sheath)		PVC		
Flame-retardant/self-extinguishing		No		
Conductor material		Cu blank		
Shielding		Braided tinned Cu		–
Weight (cable)	[kg/km]	107	78	65



5.11.2 Cable carrier installation of feedback cables

Installation type		Cable carrier		
Accessory designation		AS1H/ES1H	RH.M/RH.L	VR
Cable cross sections		6 x 2 x 0.25 mm ² (AWG 24)	5 x 2 x 0.25 mm ² (AWG 24)	3 x 1 mm ² (AWG 18)
Manufacturer		Nexans		
Manufacturer designation		SSL11YC11Y ... x 2 x 0.25		PSL 3 x 1.0
Operating voltage V ₀ / V AC	[V]	300		300
Temperature range	[°C]	-20 to +60		-30 to +70
Max. temperature	[°C]	+90 (on conductor)		+90 (on conductor)
Min. bending radius	[mm]	100	95	45
Diameter D	[mm]	9.8 ± 0.2	9.5 ± 0.2	5.7 ± 0.2
Maximum acceleration	[m/s ²]	20		10
Max. velocity	[m/min]	200		50
Core identification		WH/BN, GN/YE, GY/PK, BU/RD, BK/VT, GY-PK/RD-BU	WH/BN, GN/YE, GY/PK, BU/RD, BK/VT	2 x WH with digit + 1 x GN/YE
Sheath color		Green similar to RAL 6018		Black RAL 9005
Approval(s)		DESINA/VDE/cRUus		VDE / UL
Capacitance core/shielding	[nF/km]	100		–
Capacitance core/core	[nF/km]	55		–
Halogen-free		yes		yes
Silicone-free		yes		yes
CFC-free		yes		yes
Inner insulation (core)		PP		TPM
Outer insulation (sheath)		TPE-U		TPE-U
Flame-retardant/self-extinguishing		yes		yes
Conductor material		E-Cu blank		E-Cu blank
Shielding		Braided tinned Cu		–
Weight	[kg/km]	130	120	50
Min. bending cycles		≥ 5 million		



5.12 Connecting the motor via the terminal box

When operating with electronic control units, you must observe the relevant operating instructions/wiring diagrams.

- Connect the motor according to the enclosed wiring diagram.
- Check the cable cross sections.
- Screw on the connections and PE conductors.
- Check the winding connections in the terminal box and tighten them, if necessary.



TIP

The core colors listed in the following tables comply with the SEW-EURODRIVE cable color code in chapter "DFS/CFM synchronous servomotors – wiring diagrams" (see page 118).

5.12.1 Connection with terminal box

Motor type	Power connection			Encoder/resolver/thermal motor protection	
	Connection	Maximum connection cross section	Cable entry	Connection	Cable entry
DFS56..	Cage clamp	4 × 2.5 mm ² (AWG 14)	M20 × 1.5	Screw terminal in terminal box	M16 × 1.5
CFM71..	3 × M5	4 × 6 mm ² (AWG 10)	M25 × 1.5	Spring cage terminal in the encoder housing	M16 × 1.5
CFM90../112S	3 × M6	4 × 10 mm ² (AWG 8)	M32 × 1.5		M16 × 1.5
CFM112M/H	3 × M8	4 × 25 mm ² (AWG 4)	M50 × 1.5		M16 × 1.5

EMC compliant cabling

Make sure that

- the line type corresponds to the applicable regulations (rated currents are indicated on the nameplate),
- the signal lines consist of twisted pair wires and are collectively shielded (resolver lead as example: one pair each for reference, sine and cosine signals),
- the brake cables are routed separately from power cables, or that power cables and, if necessary, also brake cables are shielded to protect the brake against electromagnetic interference.



Motor power connection for DFS56

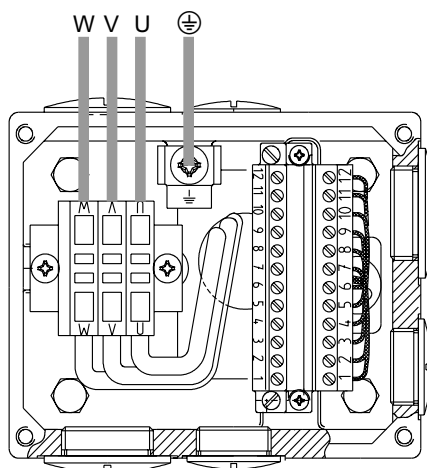

414035979

- U U phase
- V V phase
- W W phase
- y Protective earth

Connect the motor supply lines to the terminal box using the clamps.
The direction of rotation cannot be changed by changing the phases.



Electrical Installation

Connecting the motor via the terminal box

Connection of resolver/encoder and thermal motor protection for DFS56

The following figure shows the signal lines resolver/encoder and thermal motor protection:

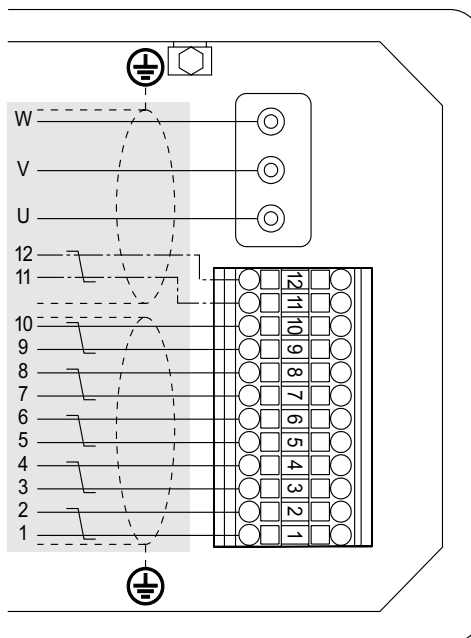

414037515

Resolver			Encoder		
1	Reference +	Reference	1	Cosine +	Cosine
2	Reference -		2	Reference cosine	Reference
3	Cosine +	Cosine	3	Sine +	Sine
4	Cosine -		4	Reference sine	Reference
5	Sine +	Sine	5	D-	Data
6	Sine -		6	D+	Data
7	-	-	7	GND	Ground
8	-	-	8	Us	Supply voltage
9	TF/KTY +	Motor protection	9	TF/KTY +	Motor protection
10	TF/KTY-		10	TF/KTY-	
11	- / 6	Brake	11	- / 6	Brake
12	+ / 5		12	+ / 5	



Power connection to CFM motor

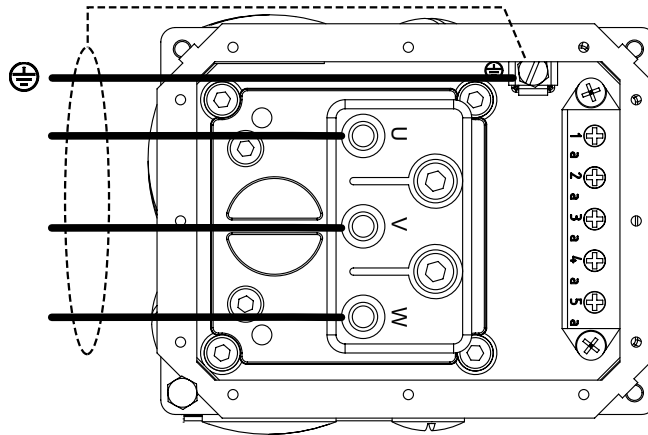

414077451

Pin	Core identification	Connection
U	Black with white lettering U, V, W (BK/WH)	U
V		V
W		W
PE	Green/yellow (GN/YE)	Protective earth

The following figure shows the power connection in the terminal box:

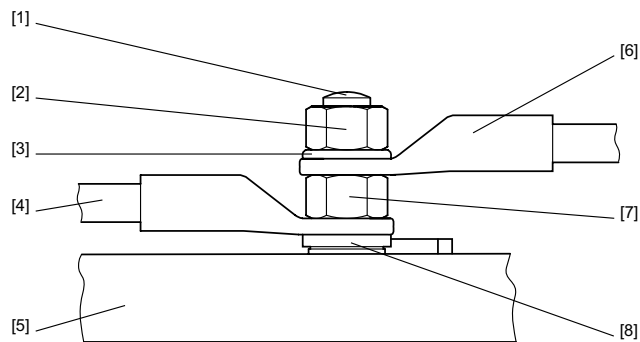

414078987

- | | |
|-------------------|----------------------|
| [1] Terminal stud | [5] Terminal board |
| [2] Upper nut | [6] Customer's cable |
| [3] Washer | [7] Lower nut |
| [4] Motor cable | [8] Lock washer |

For designing the terminal box, positions 6, 7 and 4 are regarded as current-carrying.



Electrical Installation

Connecting the motor via the terminal box

5.12.2 Connecting the motor via the terminal box

The following figure shows how to connect an RH1M resolver, for example:

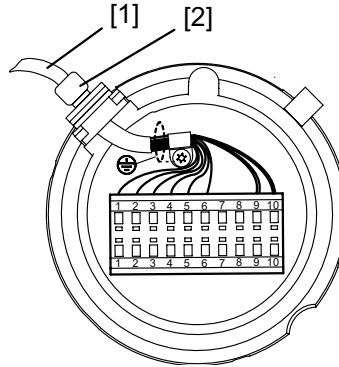

414080523

- [1] Feedback cable
[2] Cable gland

Encoder in delivery state

The housing is closed with an M16 × 1.5 screw plug. Positions 1 and 2 are not included in the scope of delivery.

Pin	RH1M/RH1L connection	AS1H/ES1H connection
1	R1 (reference +)	Cosine +
2	R2 (reference -)	Reference cosine
3	S1 (cosine +)	Sine +
4	S3 (cosine -)	Reference sine
5	S2 (sine +)	D-
6	S4 (sine -)	D+
7	-	GND ¹⁾
8	-	Us ¹⁾
9	TF (KTY+) ¹⁾	TF (KTY+)
10	TF (KTY-) ¹⁾	TF (KTY-)

1) Double assignment to increase cross section

5.12.3 Prefabricated cables for connection via terminal box

See resolver cable (see page 41) and HIPERFACE[®] encoder cable (see page 47).



5.13 Connecting the BR brake (CFM motor)

The brake is released electrically. The brake is applied mechanically when the voltage is switched off.

Comply with the applicable regulations regarding phase failure protection and the associated circuit/circuit modification.



TIP

In view of the DC voltage to be switched and the high level of current load, it is essential to use either special brake contactors or AC contactors with contacts in utilization category AC-3 according to EN 60947-4-1.

- Screw in the manual brake release lever if applicable.
- Check the winding connections in the terminal box and tighten them, if necessary.
- Connect the brake according to the enclosed wiring diagram.
- Check the cable cross sections.
- Screw on the connections and PE conductors.

The BM.. brake rectifiers or the BSG brake control unit are installed in the switch cabinet. The brake is connected with a 4-core cable.

- Check the cable cross sections – brake currents (see section "Technical Data")
- Connect the brake control according to the enclosed wiring diagram.

5.13.1 Connection with plug connector

BME brake rectifier Cut-off in the AC circuit / standard application of the brake

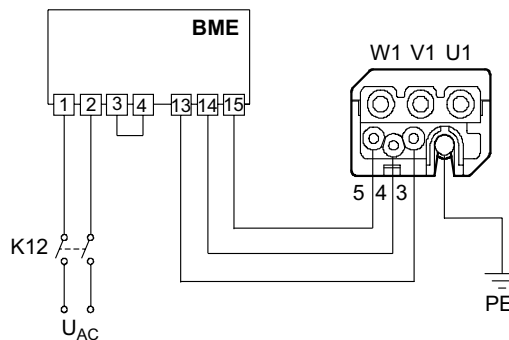

476143499



Electrical Installation

Connecting the BR brake (CFM motor)

Cut-off in the DC and AC circuit / quick application of the brake

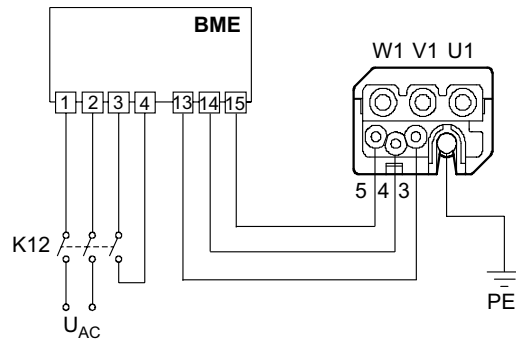

476658187

BMP brake rectifier Cut-off in the DC circuit/quick application of the brake/integrated voltage relay

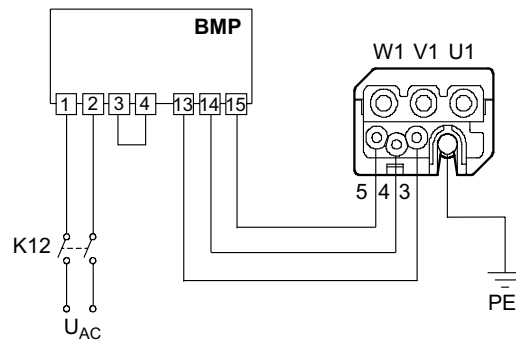

476659723

DC circuit disconnect / quick application of the brake / integrated voltage relay

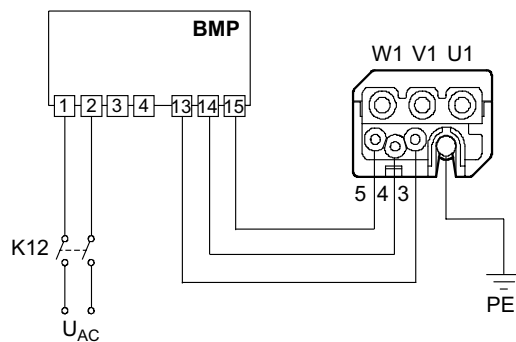

476661259



BSG brake control unit For DC 24 V supply

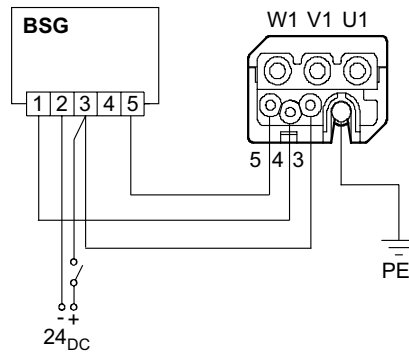

476668427

BMH brake rectifier Cut-off in the AC circuit / standard application of the brake

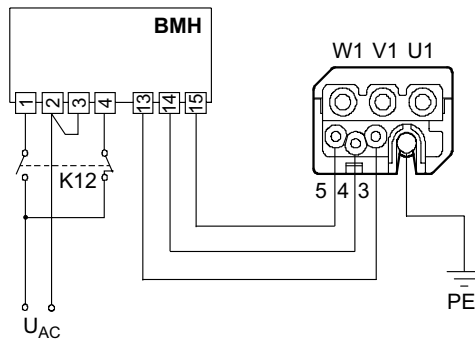

476663819

Cut-off in the DC and AC circuit / quick application of the brake

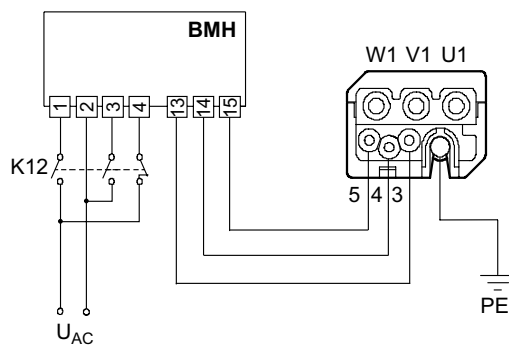

476665355



Electrical Installation

Connecting the BR brake (CFM motor)

BMK brake rectifier Cut-off in the DC and AC circuits / rapid application of the brake / integrated voltage relay / integrated DC -24 V control input

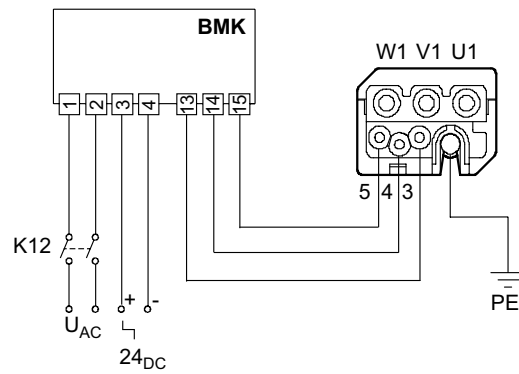

47666891



5.13.2 Connection via terminal box

The following figure shows the connection of the BR brake via terminal box.

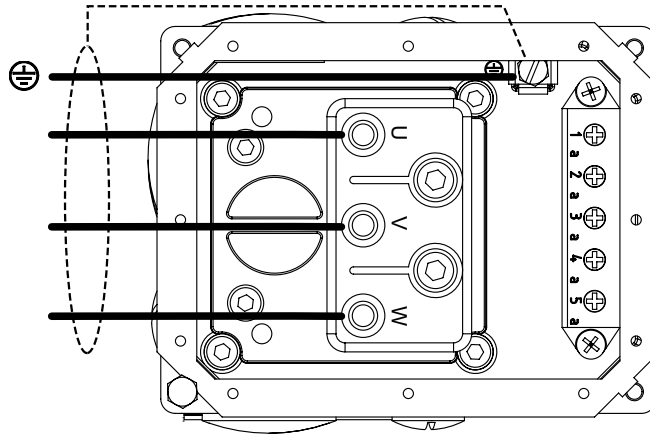

414077451

Contact of the auxiliary terminal strip	Core identification	Connection of BME, BMH, BMK, BMP brake rectifiers	Connecting the BSG brake control unit
3a	Black with white lettering 1, 2, 3 (BK/WH)	14	1
4a		13	3
5a		15	5



Electrical Installation

Connecting the BR brake (CFM motor)

Block diagrams of the brake control for terminal box

Key

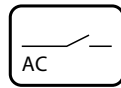

Cut-off in the AC circuit
(Standard application of the brake)

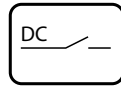

Cut-off in the DC circuit
(rapid brake application)

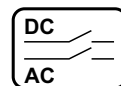

Cut-off in the DC and AC circuits
(rapid brake application)

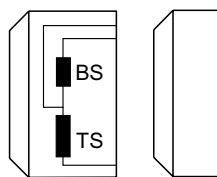

Brake
BS = Accelerator coil
TS = Coil section

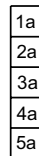

Auxiliary terminal strip in terminal box



Motor with delta connection



Motor with star connection



Control cabinet limit

WH	White
RD	Red
BU	Blue
BN	Brown
BK	Black



BME brake rectifier Cut-off in the AC circuit / standard application of the brake

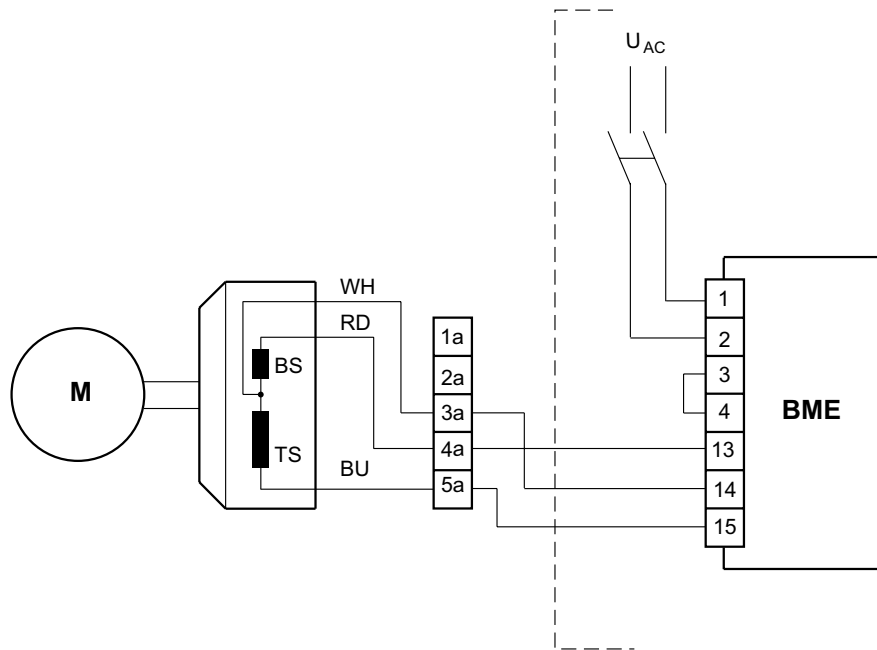
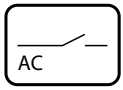

619702027

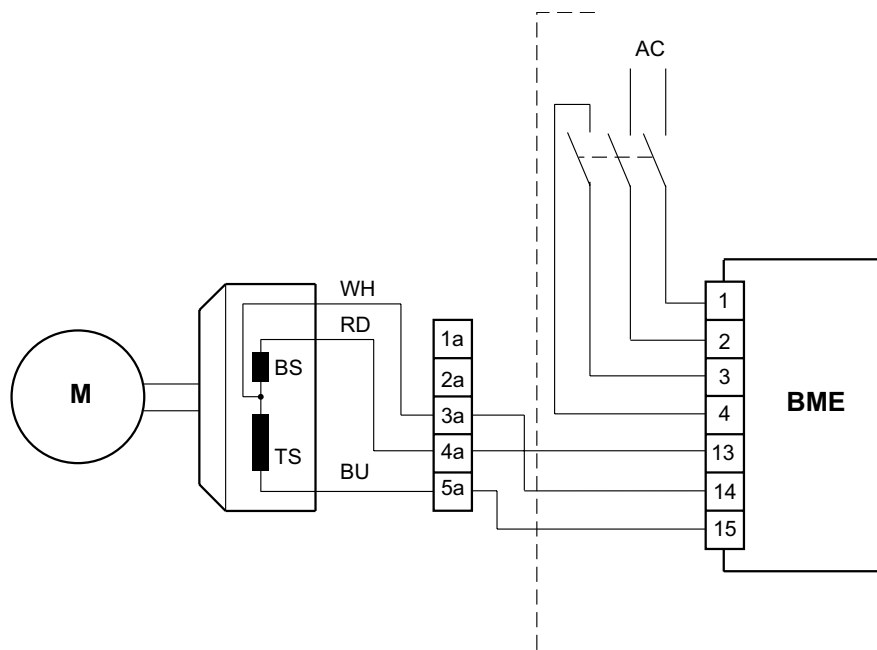
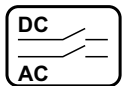

621029771



Electrical Installation
Connecting the BR brake (CFM motor)

BMP brake rectifier Cut-off in the DC and AC circuits / rapid application of the brake / integrated voltage relay

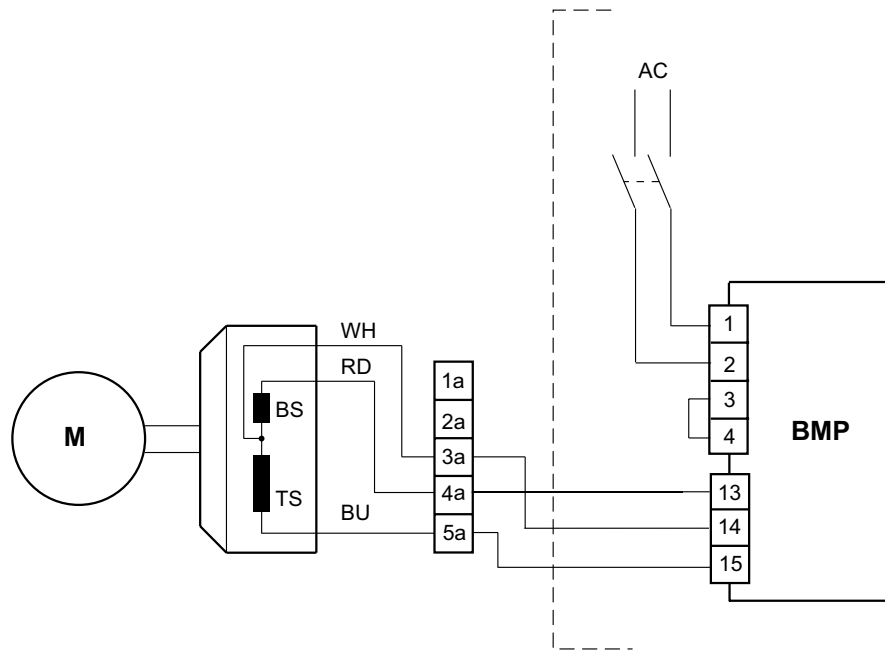

621032331

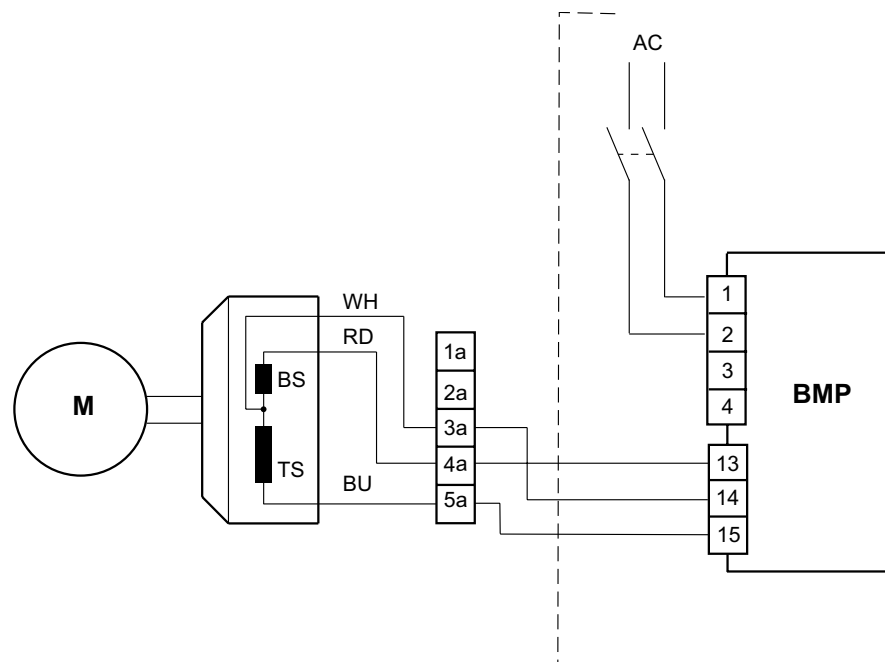

621238667



BMH brake rectifier Cut-off in the AC circuit / standard application of the brake

Apply the voltage as stated on the nameplate to release and heat the brake.

K12 not activated: Heating mode

Contact rating of the BMH terminals:

- Terminals 1 and 4: AC11
- Terminal 3: AC3 in accordance with EN 60947-4-1

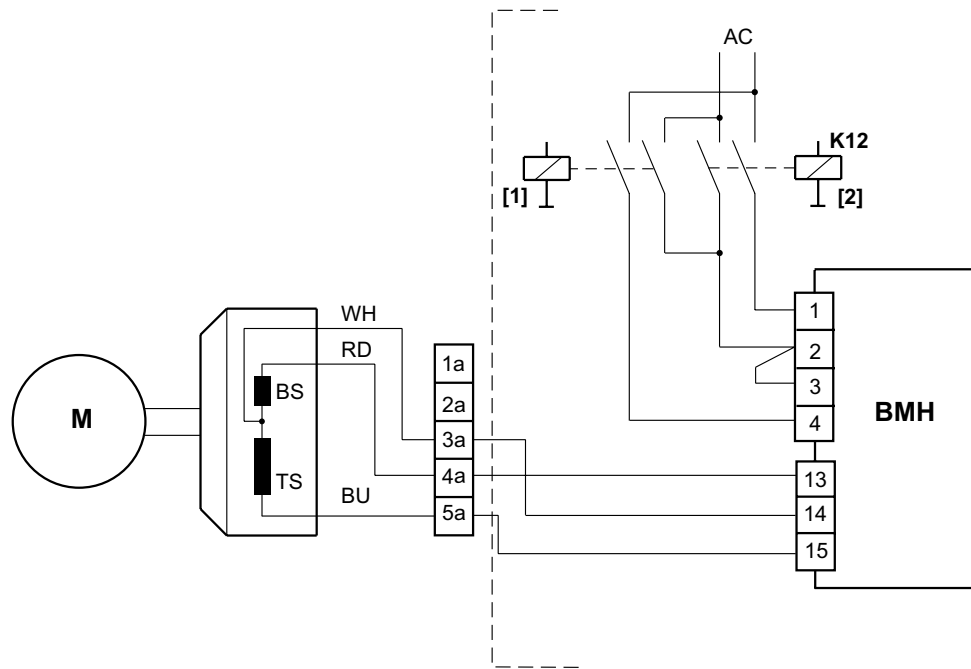

[1] Heating [2] Releasing

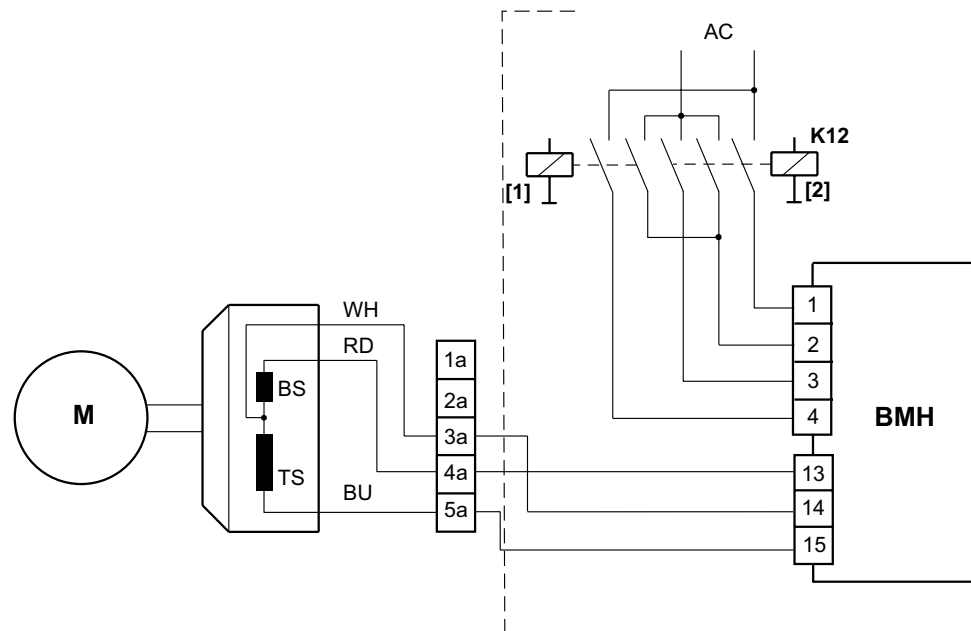

[1] Heating [2] Releasing



Electrical Installation

Connecting the BR brake (CFM motor)

BMK brake rectifier Cut-off in the DC and AC circuits / rapid application of the brake / integrated voltage relay / integrated DC -24 V control input.

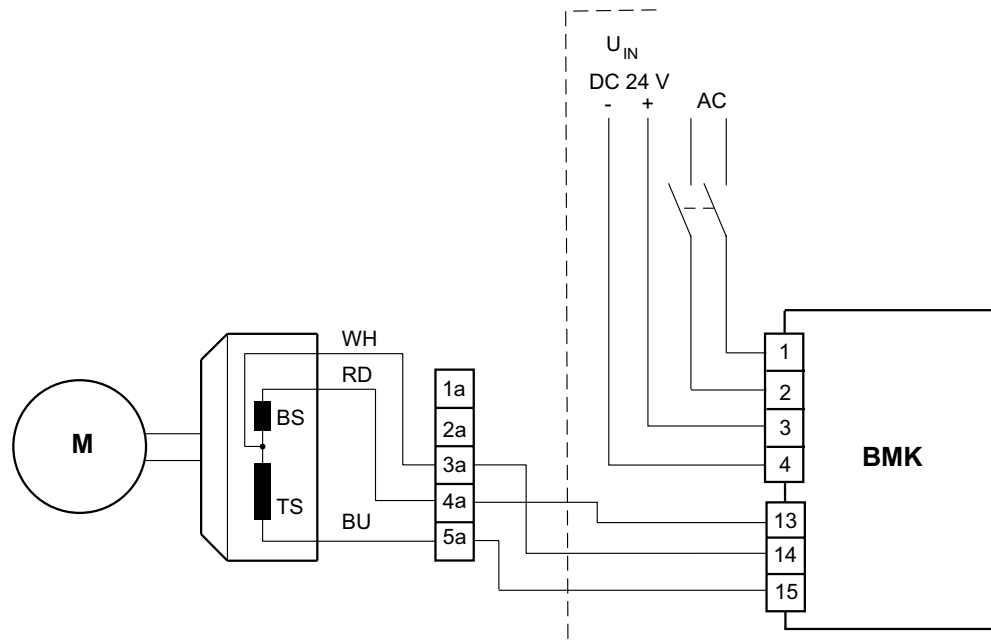

621243275

BMV brake control system Cut-off in the DC circuit / rapid application of the brake / integrated DC -24 V control input.

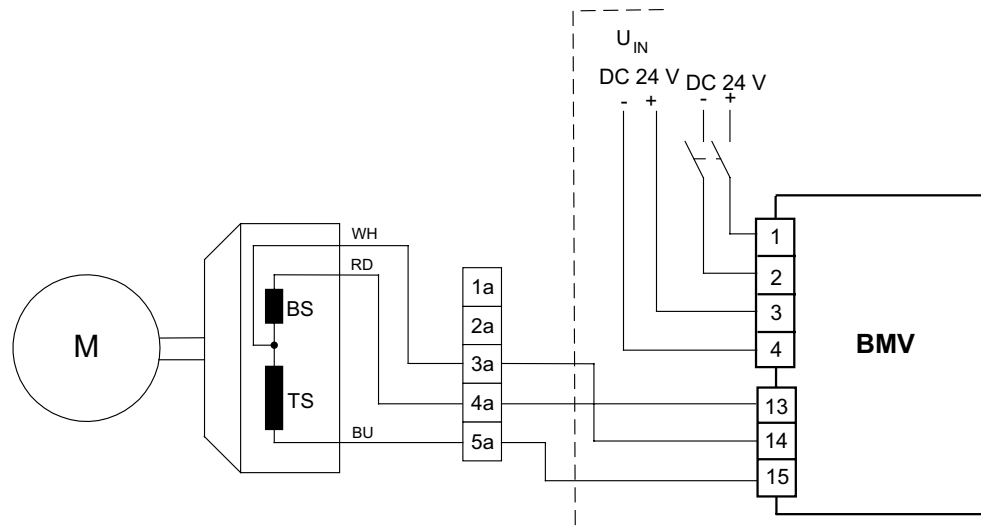
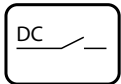

621244811



BSG control unit For DC 24 V supply.

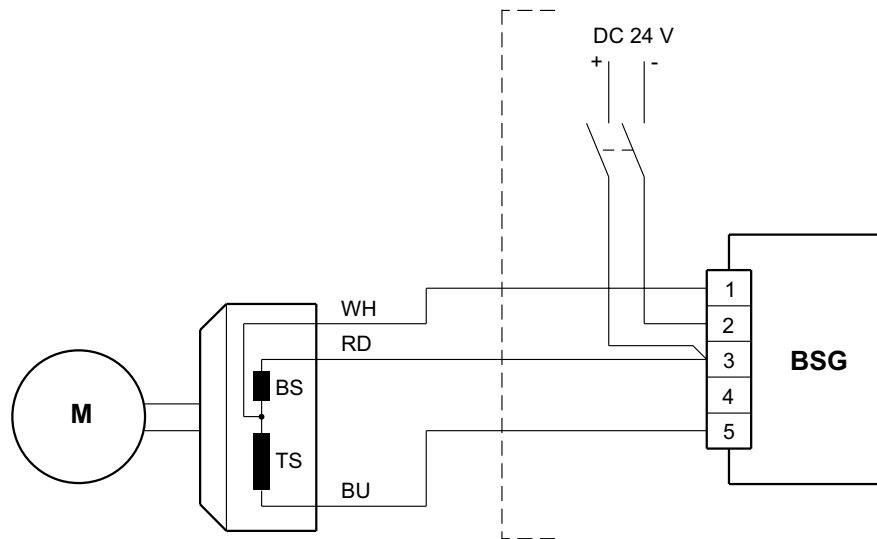
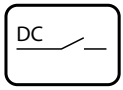

621246347

BME, BMP, BMH, BMK, BMV brake control – dimension drawing

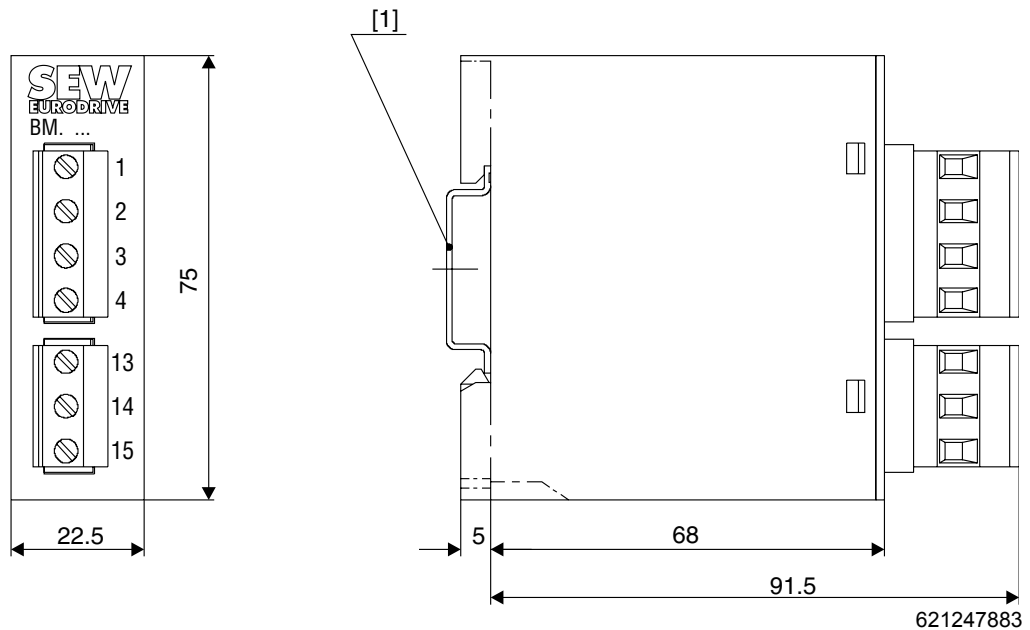

621247883

[1] Support rail mounting EN 50022-35 × 7.5



Electrical Installation

Connecting the B brake (DFS56 motor)

BSG brake control system – dimension drawing

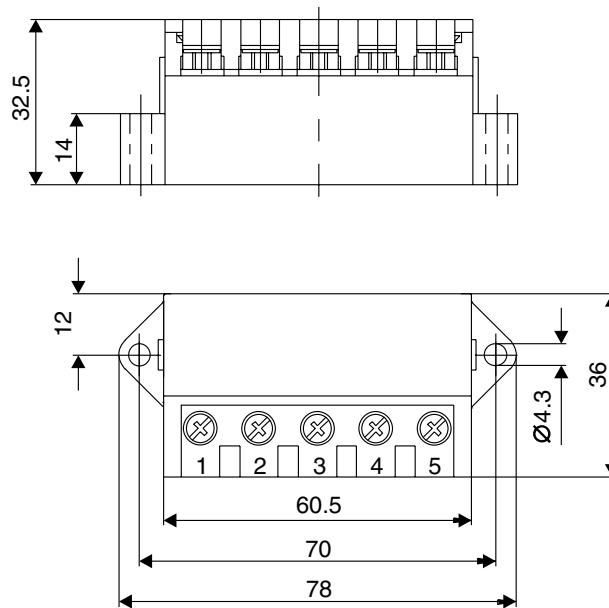

621249419

5.14 Connecting the B brake (DFS56 motor)

The brake is released electrically and has a consistent supply voltage of DC 24 V. The braking process is performed mechanically once the voltage is disconnected.

Comply with the applicable regulations regarding phase failure protection and the associated circuit/circuit modification.



TIP

In view of the DC voltage to be switched and the high level of current load, it is essential to use either special brake contactors or AC contactors with contacts in utilization category AC-3 according to EN 60947-4-1.

In order to release the brake, apply the voltage as stated on the nameplate.

Observe the following table when connecting the B brake to the servo inverter:

Inverter	Direct connection	BMV	Customer relay + BS	Customer relay + varistor
SEW-EURODRIVE MOVIDRIVE®	–	X	X	X
SEW-EURODRIVE MOVIAXIS® (up to 25 m brakemotor cable length)	X	–	–	–
SEW-EURODRIVE MOVIAXIS® (more than 25 m brakemotor cable length)	–	X	X	X
Other manufacturer	see manufacturers	X	X	X

The DS56 standard design with brake does not come with a brake control system. Provide for a suitable overvoltage protection.



The following figure shows the connection of the B brake:

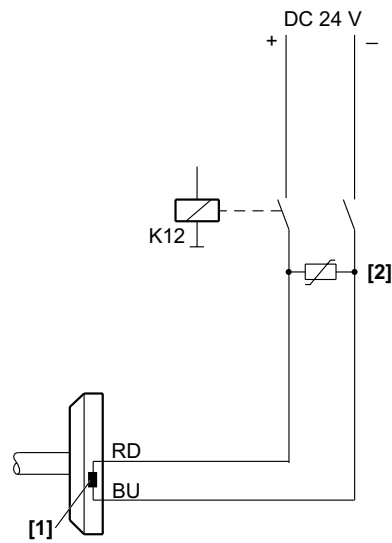

621972363

[1] Brake coil [2] Varistor

Example: Varistor for protecting the brake coil

Varistor type	Manufacturer
SIOV-S10 K300	EPCOS
10M 25 VB	Conradty



Electrical Installation

Connecting the B brake (DFS56 motor)

5.14.1 Block diagrams of the brake control system for DFS56 motors

BMV brake rectifier in the control cabinet (DIN rail mounting)

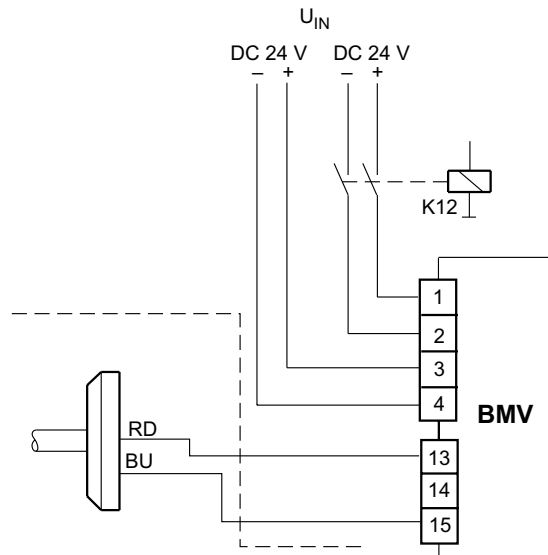

622031115

BS varistor overvoltage protection circuit (control cabinet)

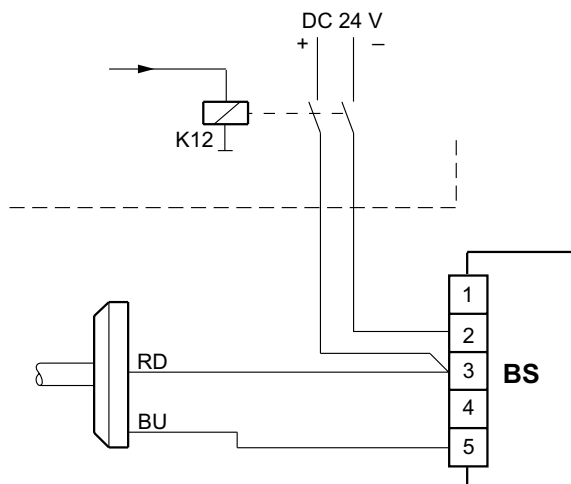

622032651



5.14.2 Connection with terminal box

- Check the winding connections in the terminal box and tighten them, if necessary.
- Connect the brake according to the enclosed wiring diagram.
- Check the cable cross sections.
- Screw on the connections and PE conductors.

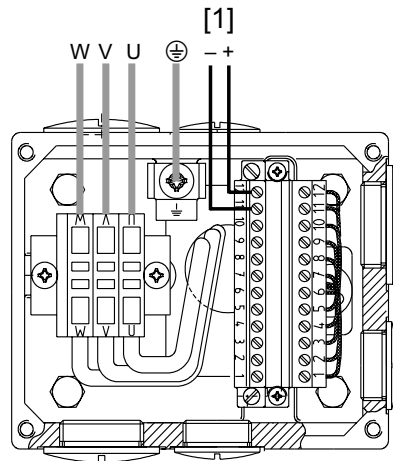

476852107

[1] Brake connection (see page 126)

5.14.3 Connection with plug connector

Power connection

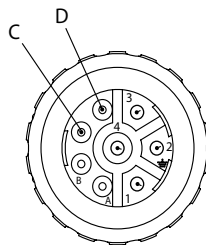

622315531

C +24 V
D 0 V

Feedback connection

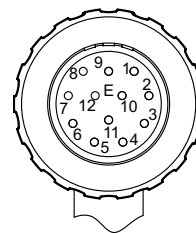

413966603



TIP

See chapter "DFS brakemotor cable" for pre-fabricated brakemotor cables (see page 30)



5.15 Accessory equipment

5.15.1 TF temperature sensor

	NOTICE
	<p>An overvoltage at the temperature sensor input can damage the motor winding and the insulation of the sensor as well as the semiconductor.</p> <p>Potential damage to property.</p> <ul style="list-style-type: none"> • Make sure that the TF evaluation unit is connected correctly. • Do not apply any voltage > 10 V.

The PTC thermistors comply with DIN 44082.

Resistance measurement (measuring instrument with $V \leq 2.5 \text{ V}$ or $I < 1 \text{ mA}$):

- Standard measured values: 20 ... 500 Ω , thermal resistance > 4000 Ω

5.15.2 KTY temperature sensor

	NOTICE
	<p>Excessive self-heating of the temperature sensor can damage the insulation of the sensor and the motor winding.</p> <p>Potential damage to property.</p> <ul style="list-style-type: none"> • Avoid currents > 4 mA in the circuit of the KTY. • Make sure that the KTY is connected properly to ensure correct evaluation of the temperature sensor.

The characteristic curve in the following figure shows the resistance curve subject to the motor temperature with a measuring current of 2 mA and correct pole connection.

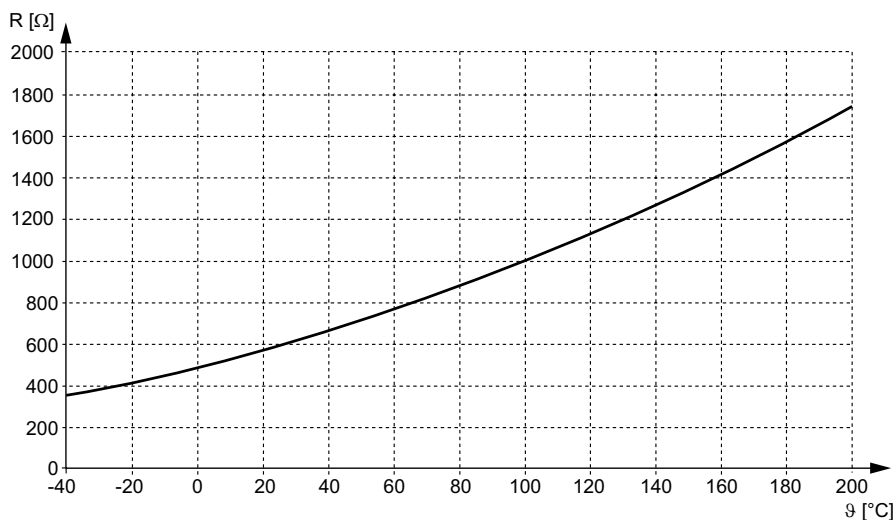

477194891

For detailed information about connecting the KTY, refer to the pin assignments of the resolver/encoder cables. Observe the correct polarity.



5.15.3 Forced cooling fan

VR forced cooling fan for CM motors

The synchronous servomotors sizes CFM71 ... CFM112 can be equipped with a VR forced cooling fan.

In addition to the fan guard you will find a bag containing the following parts for retrofitting the VR forced cooling fan:

Motor	Content of the bag
Brakemotors	<ul style="list-style-type: none"> • 1 x sleeve¹⁾ • 4 x T-slot nuts M5 • 4 x Hex head screw M5 x 8
Motor without brake	<ul style="list-style-type: none"> • 1 x sleeve¹⁾ • 4 x Holding fixture • 4 x Hex head screw M5 x 8

1) Only required for motors with SM/SB/KK5 signal plug connectors.

Mechanical installation for CFM motor without brake with plug connector (SM5./KK5.)



TIP

For CFM motors without brake with terminal box, you have to connect the signal cable before you assemble the forced cooling fan.

The following figure shows the CFM motor without brake with plug connector (SM5. / KK5.).

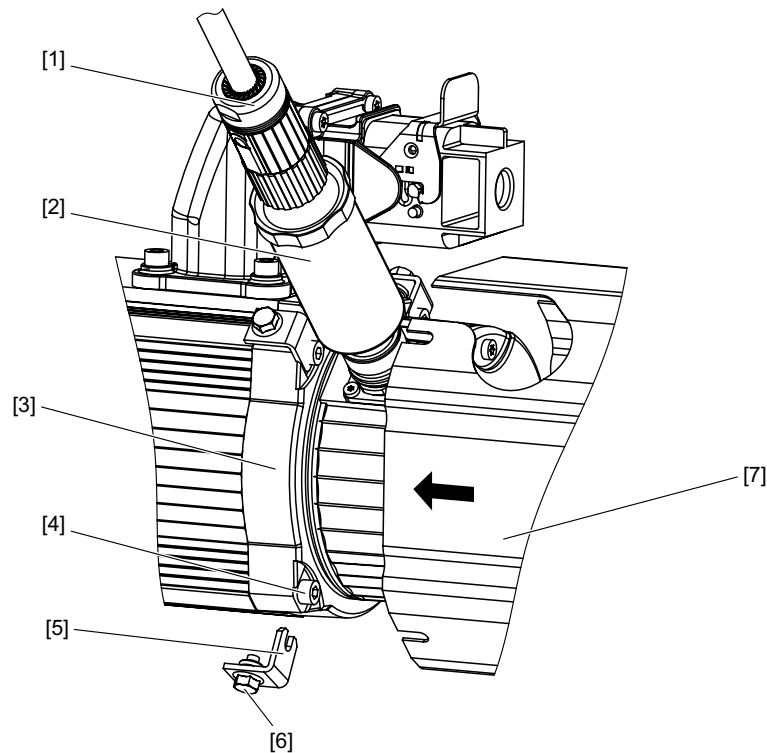

578946955

- | | |
|---------------------------------|---------------------------|
| [1] Pre-fabricated signal cable | [5] Fixture |
| [2] Sleeve | [6] Hex head screw |
| [3] B-side endshield | [7] VR forced cooling fan |
| [4] Machine screw | |



Procedure

The VR forced cooling fan is mounted to the B-side endshield using 4 holding fixtures. Proceed as follows:



TIP

Always perform the complete assembly of a holding fixture [5] at one machine screw [4] only, otherwise the encoder settings may change. See figure 578946955 (see page 85).

- Loosen the machine screw [4] by 2 to 3 revolutions.
- Position the holding fixture [5] in the recess of the B-side endshield.
- Tighten the machine screw [4]. Observe the tightening torque:

Motor size	Tightening torque [Nm]
CM71	7 (M5)
CM90	13 (M6)
CM112	28 (M8)

- Repeat the complete procedure (step 1 to 3) with the remaining 3 holding fixtures.
- Mount the forced cooling fan to the assembled holding fixtures using the hex head screws [6] (tightening torque = 6 Nm).
- Mount the round connector of the pre-fabricated cable [1] to the flange socket of the motor using the provided sleeve [2].



Mechanical installation for CFM motor with brake with terminal box

	<p>TIP</p> <p>For CFM motors with brake with plug connectors (SB5.), the signal connector is assembled according to chapter "Mechanical installation for CFM motor without brake with plug connector (SM5. / KK5.)".</p>
-----------------------------------------------------------------------------------	---------------------------------------------------------------------------------------------------------------------------------------------------------------------------------------------------------------------------------

The following figure shows the CFM motor with brake with terminal box.

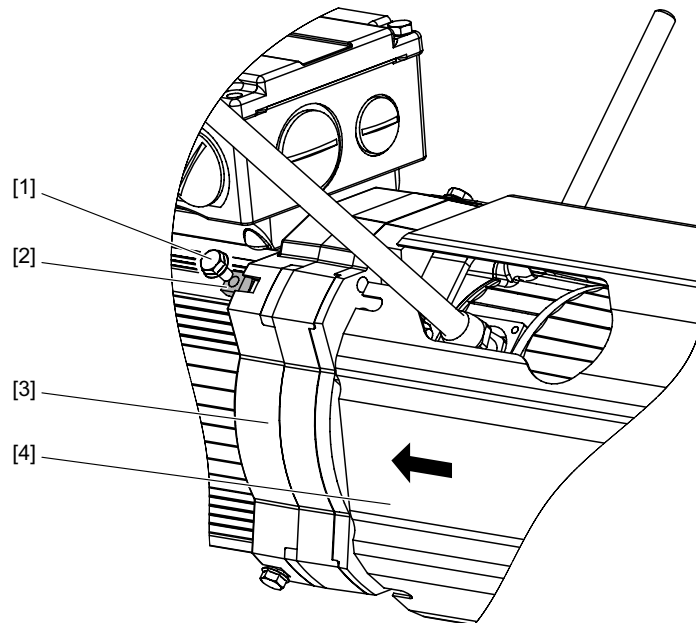

578945291

- [1] M5 × 8 screws
- [2] T-slot nut
- [3] Brake endshield
- [4] Forced cooling fan

Procedure

The VR forced cooling fan is mounted to the brake endshield using 4 T-slot nuts and 4 screws.

Proceed as follows:

- Connect the signal cable to the motor (terminal strip).
- Insert the T-slot nuts [2] to in the recess of the brake endshield [3].
- Mount the forced cooling fan [4] to the brake endshield [3] with screws [1] (tightening torque = 6 Nm).



VR forced cooling fan for DS56 servomotor

The DS56 servomotors can also be fitted with a forced cooling fan using a retrofit set.



TIP

Only authorized personnel from SEW-EURODRIVE are permitted to install the retrofit set for the forced cooling fan for DS56 motors.

Mechanical installation

The following figure shows the DS56 servomotor:



133935755

Electrical connection

This chapter applies to CFM and DFS servomotors.

The VR forced cooling fan is available for 24 V DC voltage and for 100 ... 240 V AC voltage. See chapter "VR forced cooling fan – wiring diagram" (see page 127)

- DC 24 V \pm 20%
- Plug connector connection
- Max. connection cross section $3 \times 1 \text{ mm}^2$ (AWG 18)
- Pg7 cable gland with 7 mm inside diameter

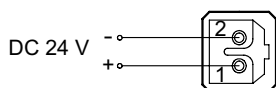

477889547

Connector contact	Connection
1	24 V +
2	0 V



5.15.4 UWU52A switched-mode power supply

The AC version consists of a VR forced cooling fan and the UWU52A switched-mode power supply (→ following figure).

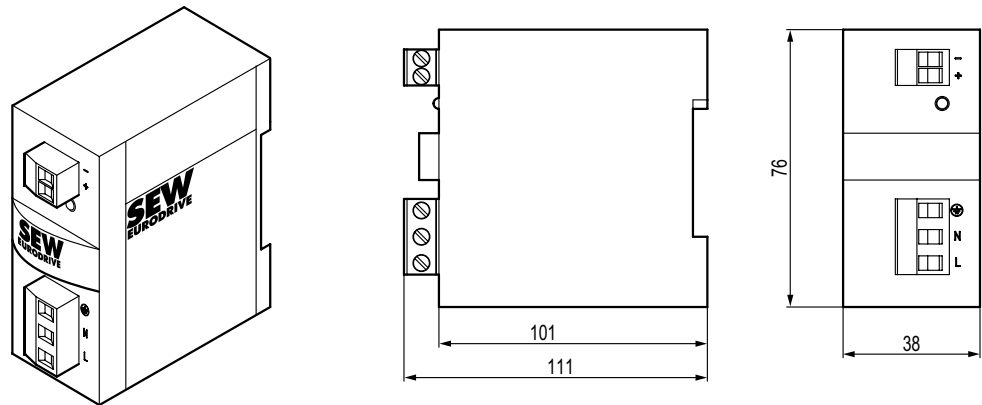

576533259

Input: AC 110 ... 240 V; 1.04 - 0.61 A; 50 / 60 Hz

DC 110 ... 300 V; 0.65 - 0.23 A

Output: DC 24 V; 2.5 A (40 °C)

DC 24 V; 2.0 A (55 °C)

Connection: Terminal screws 1.5 ... 2.5 mm², separable.

Degree of protection: IP20; attachment to EN 60715 TH35 support rail in the control cabinet.

Part number: 0188 1817.

5.15.5 HIPERFACE[®] encoder

The following notes must be observed when connecting the AS1H / ES1H HIPERFACE[®] encoder:

- Use only shielded cables with twisted pair cores.
- Connect the shield to the PE potential on both ends over a large surface area.
- Route the signal cables separately from the power or brake cables (min. distance 200 mm).



TIP

SEW-EURODRIVE recommends not to remove the plug connector of the HIPERFACE[®] encoder AS1H / ES1H while it is energized.



6 Startup

6.1 Prerequisites for startup

	! DANGER
	<p>Risk of injury due to electric shock.</p> <p>Severe or fatal injuries.</p> <ul style="list-style-type: none"> • It is essential to comply with the safety notes in section 2 during installation. • Use switch contacts in utilization category AC-3 to EN 60947-4-1 for connecting the motor and the brake. • When motors are powered from inverters, you must adhere to the wiring instructions issued by the inverter manufacturer. • Observe the operating instructions for the servo inverter.

6.1.1 Before startup

Before startup, make sure that:

- The plug connectors are protected against inadvertent loosening
- The drive is undamaged and not blocked
- The measures stipulated in section "Preliminary work" are performed after extended storage period,
- All connections have been made properly
- The direction of rotation of the motor/gearmotor is correct
- All protective covers have been installed correctly
- All motor protection equipment is active and set for the rated motor current,
- The self-reengaging manual brake release is used in case of hoist drives
- No heat-sensitive or insulating materials are covering the motor surface.
- There are no other sources of danger

6.1.2 During startup

- The motor must run correctly (no overload, no unwanted speed fluctuations, no loud noises, etc.).
- The correct braking torque must be set according to the specific application. See chapter "Work done, braking torques" (see page 106).
- In case of problems, refer chapter 7 "Malfunctions".

	NOTICE
	<p>The brakemotor can be damaged if you do not remove the hand lever after startup.</p> <p>Potential damage to property.</p> <ul style="list-style-type: none"> • On brakemotors with a self-reengaging manual brake release, the hand lever must be removed after startup.



7 Malfunctions

7.1 Motor malfunctions

Malfunction	Possible cause	Remedy
Motor does not start up	Supply cable interrupted	Check connections, correct if necessary
	Fuse has blown	Replace fuse
	Motor protection has triggered	Check motor protection for correct setting, correct fault if necessary
	Inverter faulty, overloaded, incorrectly wired or incorrectly set	Check inverter, check wiring
Incorrect direction of rotation	Motor connected incorrectly	Check inverter, check setpoints
Motor hums and has high current consumption	Drive is blocked	Check drive
	Brake does not release	See section 7.3, "Brake malfunctions"
	Encoder cable malfunction	Check encoder cable
	Wrong inverter setting	Checking the inverter
Motor heats up excessively (measure temperature, significantly higher than 110 °C)	Overload	Measure power, use larger motor or reduce load if necessary, check travel profile
	Ambient temperature is too high	Comply with permitted temperature range
	Insufficient cooling	Correct cooling air supply or clear cooling air passages, retrofit forced cooling fan if necessary
	Forced cooling fan does not run	Check connection, correct if necessary
	Rated operating mode (S1 to S10, EN 60034) exceeded, e.g. caused by excessive effective torque	Adjust the rated operating mode of the motor to the required operating conditions; consult a professional to determine the correct drive if necessary
Running noise on motor	Inverter not optimized	Check the inverter
	Bearing damage	<ul style="list-style-type: none"> • Contact SEW-EURODRIVE customer service • Replace the motor
	Vibration of rotating parts	Rectify cause, possible imbalance
	Forced cooling fan: Foreign bodies in cooling air passages	Clean the cooling air passages

7.2 Malfunctions when operated with a servo inverter

	TIP
	The symptoms described in section 7.1 may also occur when the motor is operated with a servo inverter. Refer to the servo inverter operating instructions for the meaning of the problems that occur and to find information about rectifying the problems.

Have the following information available if you require assistance from the SEW-EURODRIVE Service:

- Complete nameplate data
- Type and extent of the problem
- Time the problem occurred and any accompanying circumstances
- Assumed cause





7.3 Brake malfunctions

Malfunction	Possible cause	Remedy
Brake does not release	Incorrect voltage on brake control unit	Apply correct voltage
	Brake control unit failed	Install a new brake control system, check internal resistance and insulation of brake coil, check switchgear
	Brake connected incorrectly	Check brake connection
	Max. permitted working air gap exceeded because brake lining worn down	<ul style="list-style-type: none"> Consult SEW-EURODRIVE Replace the motor
	Voltage drop on supply cable > 10%	Correct connection voltage; check cable cross section
	Brake coil has interturn short circuit or a short circuit to frame	B brake
BR brake		<ul style="list-style-type: none"> Check switchgear Replace the entire brake and brake control system (consult SEW-EURODRIVE)
Motor does not brake	Brake lining worn down	<ul style="list-style-type: none"> Consult SEW-EURODRIVE Replace the motor
	Incorrect braking torque.	<ul style="list-style-type: none"> Consult SEW-EURODRIVE Replace the motor
	Manual brake release device not set correctly	Set the setting nuts correctly
Brake is applied with time lag	Brake is switched on AC voltage side	Switch both, the DC and AC voltage sides; observe wiring diagram
Noises in vicinity of brake	Pulsating torques due to incorrectly set frequency inverter	Check/correct setting of frequency inverter according to operating instructions



8 Inspection/Maintenance

8.1 Safety notes regarding inspection/maintenance

	<p>⚠ DANGER</p> <p>The servomotor has live parts during and after operation. Severe or fatal injuries from electric shock.</p> <ul style="list-style-type: none">• De-energize all power, brake and signal cables before unplugging the power or signal plug connector.• Safeguard against accidental startup.
	<p>⚠ CAUTION</p> <p>The surface temperature of the servomotor can exceed 100 °C during operation. Danger of burns</p> <ul style="list-style-type: none">• Never touch the servomotor during operation or in the cool down phase once the it has been switched off.• Let the servomotor cool down before you start your work.• Wear protective gloves.
	<p>NOTICE</p> <p>Only use original spare parts, otherwise the motor can be damaged. Potential damage to property.</p> <ul style="list-style-type: none">• Only use genuine spare parts in accordance with the valid parts list.



8.2 Inspection intervals

The amount of wear depends on many factors and may be high. The machine designer must calculate the required inspection intervals individually in accordance with the project planning documents (e.g. Drive Engineering – Practical Implementation: Drive Project Planning, Servo Gearmotors catalog).



TIP

Observe the manufacturer's notes in the respective maintenance schedule.

8.2.1 Cleaning

Excessive dirt, dust or shavings can have a negative impact on the function of servomotors; in extreme cases these factors can cause the servomotor to break down.

Therefore, you must clean the servomotors at regular intervals (after one year at the latest) to ensure a sufficiently large area for heat emission.

Insufficient heat emission can have unwanted consequences. The bearing service life is reduced through operation at impermissibly high temperatures (bearing grease degrades).

8.2.2 Connection cables



⚠ DANGER

The servomotor has live parts during and after operation.

Severe or fatal injuries from electric shock.

- De-energize all power, brake and signal cables before unplugging the power or signal plug connector.
- Safeguard against accidental startup.
- Do not perform temporary repairs on the connection cables. When the cable jacket is defective, no matter how small the fault, shut down the system immediately and replace the cable.

Check the connection cable for damage at regular intervals and replace if necessary.

8.3 Inspection work for the B brake (DFS)

The DFS56 brake does basically not require any maintenance work. The brake can not be retrofitted.



NOTICE

The motor must be disassembled when replacing the brake which cannot be adjusted.

Possible damages to the B brake.

- Only SEW-EURODRIVE may perform maintenance on the B brake because the encoder or resolver has to be reset each time the system is disassembled.



8.4 Inspection work for the B brake (CFM)

8.4.1 Measuring the working air gap

	<p>⚠ DANGER</p> <p>The servomotor has live parts during and after operation.</p> <p>Severe or fatal injuries from electric shock.</p> <ul style="list-style-type: none"> • De-energize all power, brake and signal cables before unplugging the power or signal plug connector. • Safeguard against accidental startup.
	<p>⚠ CAUTION</p> <p>The surface temperature of the servomotor can exceed 100 °C during operation.</p> <p>Danger of burns</p> <ul style="list-style-type: none"> • Never touch the servomotor during operation or in the cool down phase once the it has been switched off. • Let the servomotor cool down before you start your work. • Wear protective gloves.

The working air gap cannot be readjusted and can only be measured via the stroke of the pressure plate when the brake is released.

- Isolate the motor and brake from the supply, safeguarding them against unintentional power-up.
- For motors with a forced-cooling fan, remove the metal cover from the motor.
- Connect the brake to the power supply.
- Via the stroke of the pressure plate measure the working air gap that appears during the electrical application/release process, using the two pressure pins ΔH (see following figure). A range of 0.15 ... 0.8 mm is permitted.

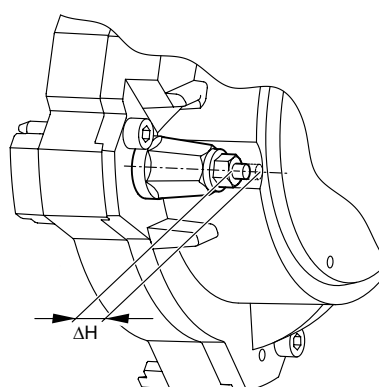

478583435

- If the working air gap > 0.8 mm, replace the entire brake. Only SEW-EURODRIVE may replace the brake.



Inspection/Maintenance

Inspection work for the B brake (CFM)

8.4.2 Retrofitting the manual brake release CFM71 and CFM90

Manual brake release

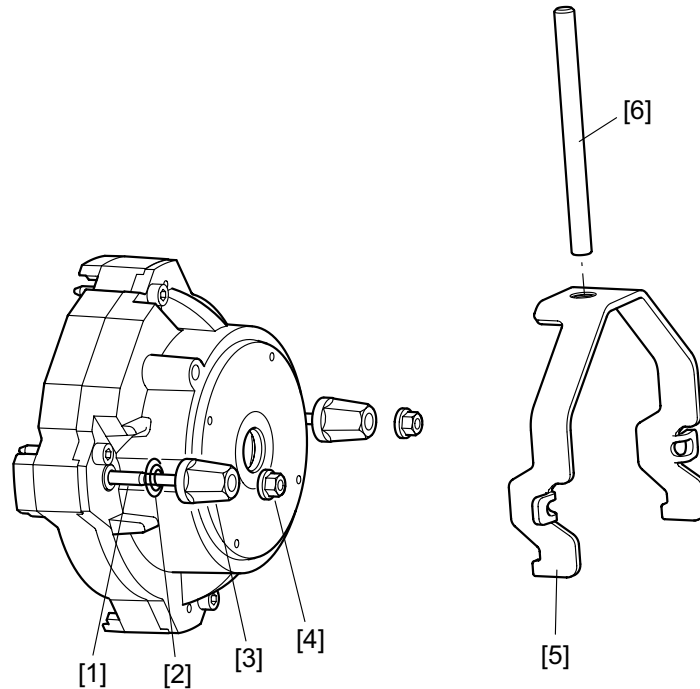

[1] Stud
[2] Conical spring

[3] Sleeve
[4] Hex nut

[5] Release lever
[6] Hand lever

706627467



Procedure Proceed as follows:

Step	Procedure	Illustration
1	Loosen both hex nuts [4].	
2	Remove the sleeves [3] and the hub conical springs [2].	
3	Stick the levers [5] on the studs [1].	
4	Stick the provided conical springs [2] on the studs [1].	
5	Screw the hex nuts [4] on the studs [1].	
6	Screw the hand lever [6] into the release lever [5].	
7	On both sides, set a floating clearance [s] of 2 mm between the lug of the release lever [5] and the hex nut [4].	



8.4.3 Retrofitting the manual brake release CFM112

Manual brake release

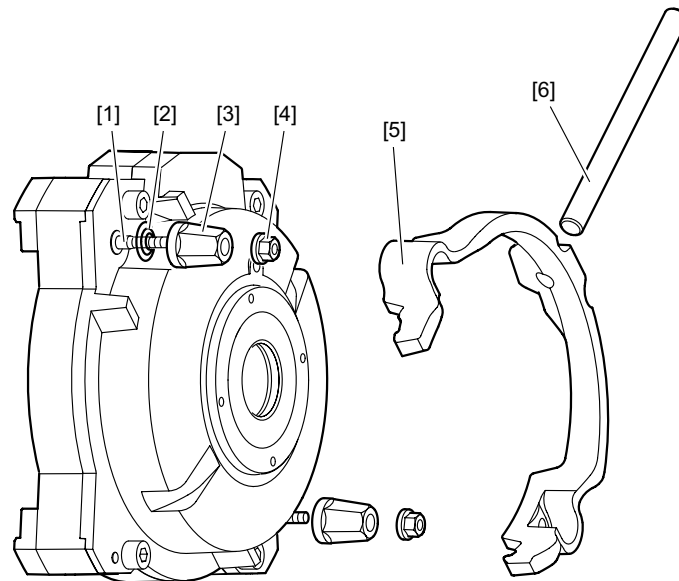

[1] Stud
[2] Conical spring

[3] Sleeve
[4] Hex nut

[5] Release lever
[6] Hand lever

1244130827



Procedure Proceed as follows:

Step	Procedure	Illustration
1	Loosen both hex nuts [4].	
2	Remove the sleeves [3] and the hub conical springs [2].	
3	Stick the levers [5] on the studs [1].	
4	Stick the provided conical springs [2] on the studs [1].	
5	Screw the hex nuts [4] all the way on the studs [1]. Loosen the hex nuts [4] by 2 revolutions to set the floating clearance.	
6	Screw the hand lever [6] into the release lever [5].	

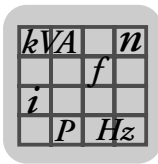

Technical Data

Main technical data of the servomotors

9 Technical Data

9.1 Main technical data of the servomotors

9.1.1 Key to the technical data

n_N	Rated speed
M_0	Standstill torque (thermal continuous torque at low speeds)
I_0	Standstill current
M_{pk}	Dynamic limit torque
I_{max}	Maximum permitted motor current
M_{0VR}	Standstill torque with forced cooling fan
I_{0VR}	Standstill current with forced cooling fan
J_{mot}	Mass moment of inertia of the motor
J_{bmot}	Mass moment of inertia of the brakemotor
M_{B1}	Standard braking torque
M_{B2}	Optional braking torque
W_{max1}	Maximum possible braking work with standard braking torque during a maintenance interval
W_{max2}	Maximum possible braking work with optional braking torque during a maintenance interval
L_1	Inductivity between connection phase and star point
R_1	Resistance between connection phase and star point
$U_{p0 \text{ cold}}$	Internal voltage at 1000 rpm
m_{mot}	Mass of the motor
m_{bmot}	Mass of the brakemotor

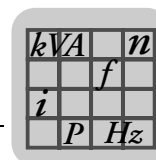

9.1.2 Technical data of DFS/CFM motors

Synchronous servomotors with 400 V system voltage

n_N [rpm]	Motor	M_0 [Nm]	I_0 [A]	M_{pk} [Nm]	I_{max} [A]	M_{0VR} [Nm]	I_{0VR} [A]	J_{mot} [10 ⁻⁴]	J_{bmot} kgm ²	M_{B1} [Nm]	M_{B2} [Nm]	W_{max1} [kJ]	W_{max2} [kJ]
2000	CFM71S	5	2.2	16.5	8.8	7.3	3.2	4.89	6.65	10	5	18	22
	CFM71M	6.5	3	21.5	12	9.4	4.2	6.27	8.03	14	7	15	20
	CFM71L	9.5	4.2	31.4	16.8	13.8	6.1	9.02	10.8	14	10	15	18
	CFM90S	11	4.9	39.6	19.6	16	7.1	17.4	21.2	28	14	17	24
	CFM90M	14.5	6.9	52.2	28	21	10	22.3	26.1	40	20	10.5	19.5
	CFM90L	21	9.9	75.6	40	30.5	14.4	32.1	35.9	40	28	10.5	17
	CFM112S	23.5	10	82.3	40	34	14.5	68.4	84	55	28	32	48
	CFM112M	31	13.5	108.5	54	45	19.6	88.2	104	90	40	18	44
	CFM112L	45	20	157.5	80	65	29	128	143	90	55	18	32
CFM112H	68	30.5	238.0	122	95	42.5	190	209	90	55	18	32	
3000	DFS56M	1	1.65	3.8	6.6	–	–	0.48	0.83	2.5	–	–	–
	DFS56L	2	2.4	7.6	9.6	–	–	0.83	1.18	2.5	–	–	–
	DFS56H	4	2.8	15.2	11.2	–	–	1.53	1.88	5	–	–	–
	CFM71S	5	3.3	16.5	13.2	7.3	4.8	4.89	6.65	10	5	14	20
	CFM71M	6.5	4.3	21.5	17.2	9.4	6.2	6.27	8.03	14	7	11	18
	CFM71L	9.5	6.2	31.4	25	13.8	9	9.02	10.8	14	10	11	14
	CFM90S	11	7.3	39.6	29	16	10.6	17.4	21.2	28	14	10	20
	CFM90M	14.5	10.1	52.2	40	21	14.6	22.3	26.1	40	20	4.5	15
	CFM90L	21	14.4	75.6	58	30.5	21	32.1	35.9	40	28	4.5	10
	CFM112S	23.5	15	82.3	60	34	22	68.4	84	55	28	18	36
	CFM112M	31	20.5	108.5	82	45	30	88.2	104	90	40	7	32
	CFM112L	45	30	157.5	120	65	44	128	143	90	55	7	18
CFM112H	68	43	238.0	172	95	60	190	209	90	55	7	18	
4500	DFS56M	1	1.65	3.8	6.6	–	–	0.48	0.83	2.5	–	–	–
	DFS56L	2	2.4	7.6	9.6	–	–	0.83	1.18	2.5	–	–	–
	DFS56H	4	4	15.2	16	–	–	1.53	1.88	5	–	–	–
	CFM71S	5	4.9	16.5	19.6	7.3	7.2	4.89	6.65	10	5	10	16
	CFM71M	6.5	6.6	21.5	26	9.4	9.6	6.27	8.03	14	7	6	14
	CFM71L	9.5	9.6	31.4	38	13.8	14	9.02	10.8	14	10	6	10
	CFM90S	11	11.1	39.6	44	16	16.2	17.4	21.2	28	14	5	15
	CFM90M	14.5	14.7	52.2	59	21	21.5	22.3	26.1	40	20	3	9
	CFM90L	21	21.6	75.6	86	30.5	31.5	32.1	35.9	40	28	3	5
	CFM112S	23.5	22.5	82.3	90	34	32.5	68.4	84	55	25	11	22
	CFM112M	31	30	108.5	120	45	44	88.2	104	90	40	4	18
	CFM112L	45	46	157.5	184	65	67	128	143	90	55	4	11
CFM112H	68	66	238.0	264	95	92	190	209	90	55	4	11	
6000	DFS56M	1	1.65	3.8	6.6	–	–	0.48	0.83	2.5	–	–	–
	DFS56L	2	2.75	7.6	11	–	–	0.83	1.18	2.5	–	–	–
	DFS56H	4	5.3	15.2	21	–	–	1.53	1.88	5	–	–	–
	CFM71S	5	6.5	16.5	26	7.3	9.5	4.89	–	–	–	–	–
	CFM71M	6.5	8.6	21.5	34	9.4	12.5	6.27	–	–	–	–	–
	CFM71L	9.5	12.5	31.4	50	13.8	18.2	9.02	–	–	–	–	–
	CFM90S	11	14.5	39.6	58	16	21	17.4	–	–	–	–	–
	CFM90M	14.5	19.8	52.2	79	21	29	22.3	–	–	–	–	–
CFM90L	21	29.5	75.6	118	30.5	43	32.1	–	–	–	–	–	

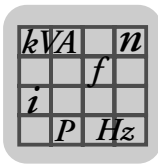

Technical Data

Main technical data of the servomotors

n_N	Motor	L_1	R_1	U_{p0}	m_{mot}	m_{bmot}
[rpm]		[mH]	[mΩ]	[V/1000 rpm]	[kg]	
2000	CFM71S	52	7090	151	9.5	11.8
	CFM71M	36	4440	148	10.8	13.0
	CFM71L	24	2500	152	13.0	15.3
	CFM90S	18	1910	147	15.7	19.6
	CFM90M	12.1	1180	141	17.8	21.6
	CFM90L	8.4	692	146	21.9	26.5
	CFM112S	10	731	155	26.2	31.8
	CFM112M	7.5	453	153	30.5	36.0
	CFM112L	4.6	240	151	39.3	44.9
	CFM112H	2.6	115	147	54.2	59.8
3000	DFS56M	9.7	5700	40	2.8	2.9
	DFS56L	8.8	3700	56	3.5	3.6
	DFS56H	12.7	4500	97	4.8	5.3
	CFM71S	23	3150	101	9.5	11.8
	CFM71M	16	2000	100	10.8	13.0
	CFM71L	11	1120	102	13.0	15.3
	CFM90S	8.1	838	98	15.7	19.6
	CFM90M	5.7	533	96	17.8	21.6
	CFM90L	3.9	324	99	21.9	26.5
	CFM112S	4.6	325	103	26.2	31.8
	CFM112M	3.1	193	99	30.5	36.0
	CFM112L	2	103	101	39.3	44.9
	CFM112H	1.3	57	104	54.2	59.8
	4500	DFS56M	9.7	5700	40	2.8
DFS56L		8.8	3700	56	3.5	3.6
DFS56H		6.2	2200	67.5	4.8	5.3
CFM71S		10	1380	66	9.5	11.8
CFM71M		6.9	828	64	10.8	13.0
CFM71L		4.9	446	65	13.0	15.3
CFM90S		3.45	358	64	15.7	19.6
CFM90M		2.65	249	65	17.8	21.6
CFM90L		1.73	148	66	21.9	26.5
CFM112S		2	149	69	26.2	31.8
CFM112M		1.5	92	68	30.5	36.0
CFM112L		0.85	44	66	39.3	44.9
CFM112H		0.54	24	67	54.2	59.8
6000		DFS56M	9.70	5700	40	2.8
	DFS56L	6.80	2800	49	3.5	3.6
	DFS56H	3.50	1200	50.5	4.8	5.3
	CFM71S	5.75	780	50	9.5	–
	CFM71M	3.93	493	49	10.8	–
	CFM71L	2.68	277	50	13.0	–
	CFM90S	2.03	212	49	15.7	–
	CFM90M	1.48	136	48	17.8	–
	CFM90L	0.93	77	48	21.9	–

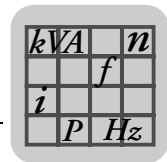

Synchronous servomotors with 230 V system voltage

n_N [rpm]	Motor	M_0 [Nm]	I_0 [A]	M_{pk} [Nm]	I_{max} [A]	M_{0VR} [Nm]	I_{0VR} [A]	J_{mot} [10 ⁻⁴ kgm ²]	J_{bmot} [10 ⁻⁴ kgm ²]	M_{B1} [Nm]	M_{B2} [Nm]	W_{max1} [kJ]	W_{max2} [kJ]
2000	CFM71S	5	3.95	16.5	15.8	7.3	5.7	4.89	6.65	10	5	18	22
	CFM71M	6.5	5.3	21.5	21	9.4	7.7	6.27	8.03	14	7	15	20
	CFM71L	9.5	7.4	31.4	29.5	13.8	10.7	9.02	10.8	14	10	15	18
	CFM90S	11	8.7	39.6	35	16	12.6	17.4	21.2	28	14	17	24
	CFM90M	14.5	12.1	52.2	48.5	21	17.5	22.3	26.1	40	20	10.5	19.5
	CFM90L	21	17.1	75.6	68	30.5	25	32.1	35.9	40	28	10.5	17
	CFM112S	23.5	18	82.3	72	34	26	68.4	84	55	28	32	48
	CFM112M	31	24.5	108.5	98	45	35.5	88.2	104	90	40	18	44
	CFM112L	45	35.5	157.5	142	65	51	128	143	90	55	18	32
3000	DFS56M	1	1.65	3.8	6.6	–	–	0.48	0.83	2.5	–	–	–
	DFS56L	2	2.4	7.6	9.6	–	–	0.83	1.18	2.5	–	–	–
	CFM71S	5	5.9	16.5	23.5	7.3	8.6	4.89	6.65	10	5	14	20
	CFM71M	6.5	7.6	21.5	30.5	9.4	11	6.27	8.03	14	7	11	18
	CFM71L	9.5	11.1	31.4	44.5	13.8	16.1	9.02	10.8	14	10	11	14
	CFM90S	11	12.7	39.6	51	16	18.4	17.4	21.2	28	14	10	20
	CFM90M	14.5	17.4	52.2	70	21	25	22.3	26.1	40	20	4.5	15
	CFM90L	21	25.5	75.6	102	30.5	37	32.1	35.9	40	28	4.5	10
	CFM112S	23.5	27	82.3	108	34	39	68.4	84	55	28	18	36
	CFM112M	31	35	108.5	140	45	51	88.2	104	90	40	7	32
CFM112L	45	48	157.5	192	65	70	128	143	90	55	7	18	
4500	CFM71S	5	8.5	16.5	34	7.3	12.3	4.89	6.65	10	5	10	16
	CFM71M	6.5	11.3	21.5	45	9.4	16.4	6.27	8.03	14	7	6	14
	CFM71L	9.5	17.1	31.4	68	13.8	25	9.02	10.8	14	10	6	10
	CFM90S	11	18.9	39.6	76	16	27.5	17.4	21.2	28	14	5	15
	CFM90M	14.5	26	52.2	104	21	37.5	22.3	26.1	40	20	3	9
	CFM90L	21	39	75.6	156	30.5	57	32.1	35.9	40	28	3	5
	CFM112S	23.5	38.5	82.3	154	34	56	68.4	84	55	25	11	22
	CFM112M	31	54	108.5	216	45	78	88.2	104	90	40	4	18
6000	CFM71S	5	11.6	16.5	46.5	7.3	16.8	4.89	–	–	–	–	–
	CFM71M	6.5	14.1	21.5	56	9.4	20.5	6.27	–	–	–	–	–
	CFM71L	9.5	21.5	31.4	86	13.8	31	9.02	–	–	–	–	–
	CFM90S	11	23.5	39.6	94	16	34	17.4	–	–	–	–	–
	CFM90M	14.5	37	52.2	148	21	54	22.3	–	–	–	–	–
	CFM90L	21	51	75.6	204	30.5	74	32.1	–	–	–	–	–

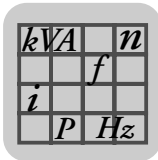

Technical Data

Main technical data of the servomotors

n_N	Motor	L_1	R_1	U_{p0}	m_{mot}	m_{bmot}
[rpm]		[mH]	[mΩ]	[V/1000 rpm]	[kg]	
2000	CFM71S	16.3	2188	85	9.5	11.8
	CFM71M	11.4	1394	83	10.8	13.0
	CFM71L	7.7	802	86	13.0	15.3
	CFM90S	5.7	593	83	15.7	19.6
	CFM90M	3.95	382	81	17.8	21.6
	CFM90L	2.80	236	85	21.9	26.5
	CFM112S	3.10	225	86	26.2	31.8
	CFM112M	2.25	127	84	30.5	36.0
	CFM112L	1.46	76	85	39.3	44.9
3000	DFS56M	9.7	5700	40	2.8	2.9
	DFS56L	8.8	3700	56	3.5	3.6
	CFM71S	7.2	973	57	9.5	11.8
	CFM71M	5.2	642	57	10.8	13.0
	CFM71L	3.45	347	57	13.0	15.3
	CFM90S	2.7	271	57	15.7	19.6
	CFM90M	1.91	182	56	17.8	21.6
	CFM90L	1.24	105	56	21.9	26.5
	CFM112S	1.42	100	57	26.2	31.8
	CFM112M	1.08	67	58	30.5	36.0
	CFM112L	0.78	35	63	39.3	44.9
4500	CFM71S	3.30	449	38	9.5	11.8
	CFM71M	2.35	278	37.5	10.8	13.0
	CFM71L	1.55	149	36.5	13.0	15.3
	CFM90S	1.19	124	37.5	15.7	19.6
	CFM90M	0.84	81	36.5	17.8	21.6
	CFM90L	0.53	48	36.5	21.9	26.5
	CFM112S	0.68	50	40.5	26.2	31.8
	CFM112M	0.465	28	38	30.5	36.0
6000	CFM71S	1.80	243	28	9.5	–
	CFM71M	1.47	175	30	10.8	–
	CFM71L	0.91	89	29	13.0	–
	CFM90S	0.77	78	30	15.7	–
	CFM90M	0.42	42	25.5	17.8	–
	CFM90L	0.31	26	28	21.9	–

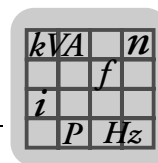

9.2 Plug connectors

Plug connectors	Power plug connector		Signal plug connector	
	Socket contact	max. cable diameter [mm]	Socket contact	max. cable diameter [mm]
SM11	4 × 1.5 mm ²	14	10 x 0.06 ... 1 mm ²	10.5
SB11	4 × 1.5 mm ² + 2 × 0.5 ... 1.5 mm ²			
SM51/SM61	4 × 1.5 mm ²			
SB51/SB61	4 × 1.5 mm ² + 3 × 0.5 ... 1.5 mm ²			
SM52/SM62	4 × 2.5 mm ²			
SB52/SB62	4 × 2.5 mm ² + 3 × 0.5 ... 1.5 mm ²	17		
SM54/SM64	4 × 4 mm ²			
SB54/SB64	4 × 4 mm ² + 3 × 0.5 ... 1.5 mm ²			
SM56/SM66	4 × 6 mm ²	23		
SB56/SB66	4 × 6 mm ² + 3 × 0.5 ... 1.5 mm ²			
SM59/SM69	4 × 10 mm ²			
SB59/SB69	4 × 10 mm ² + 3 × 0.5 ... 1.5 mm ²			

9.3 Connection with terminal box

Motor type	Power connection			Encoder/resolver/thermal motor protection	
	Connection	maximum connection cross section	Cable entry	Connection	Cable entry
DFS56..	Cage clamp	4 x 2.5 mm ²	M20 x 1.5	Screw terminal in terminal box	M16 x 1.5
CFM71..	3 x M5	4 x 6 mm ²	M25 x 1.5	Spring cage terminal in the encoder housing	M16 x 1.5
CFM90../112S	3 x M6	4 x 10 mm ²	M32 x 1.5		M16 x 1.5
CFM112M/H	3 x M8	4 x 25 mm ²	M50 x 1.5		M16 x 1.5

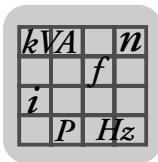

9.4 Work done, braking torques

Brake	For motor size	Work done until maintenance [10 ⁶ J]	Braking torque [Nm]
B	DFS56H	–	5
B	DFS56M/L	–	2.5
BR1	CFM71	60	5
			7
			10
			14
BR2	CFM90	90	20
			28
			40
			14
BR8	CFM112	180	28
			40
			55
			90

9.5 Brake coil resistance

Brake	V _N									
	DC 24 V		AC 110 V		AC 230 V		AC 400 V		AC 460 V	
	R _B [Ω]	R _T [Ω]	R _B [Ω]	R _T [Ω]	R _B [Ω]	R _T [Ω]	R _B [Ω]	R _T [Ω]	R _B [Ω]	R _T [Ω]
B	43		–		–		–		–	
BR1	3.7	11.2	11.8	35.4	59.2	178	187	561	236	707
BR2	3.3	9.8	10.5	31.0	52.6	156	158	469	199	590
BR8	1.4	7.2	4.4	22.7	21.9	114	69.3	359	87.2	452

The following figure is a schematic representation of the BR brake and the connection.

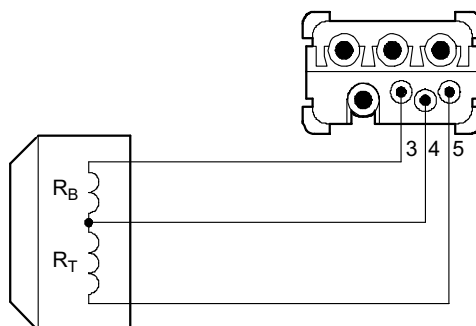

480161803

R_B Resistance of accelerator coil at 20 °C
 R_T Coil section resistance at 20°C
 V_N Rated voltage (rated voltage range)

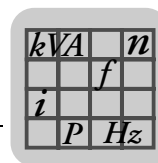

9.6 BR brake – operating currents

The current values I_H (holding current) listed in the tables are r.m.s. values. Use only r.m.s. instruments for your measurement. The inrush current (accelerator current) I_B only flows for a short time (max. 150 ms) when the brake is released or during voltage dips below 70% of rated voltage. There is no increased inrush current if the BG brake rectifier is used or if there is a direct DC voltage supply - both are only possible with brakes up to motor size BMG4.

Brake	B		BR1	BR2	BR8	
For motor	DFS56M/L	DFS56H	CFM71	CFM90	CFM112	
M_{Bmax} [Nm]	2.5	5	20	40	90	
P_B [W]	12	13.4	45	55	75	
Inrush current ratio I_B/I_H	–	–	4.0	4.0	6.3	
Rated voltage V_N (...) Voltage tolerances	I [A _{DC}]	I [A _{DC}]	I_H [A _{AC}]	I_H [A _{AC}]	I_H [A _{AC}]	
[V _{AC}]	[V _{DC}]					
–	24 (24 ... 25)	0.50	0.56	1.55	1.9	2.4
110 (99 ... 121)	–	–	–	0.66	0.72	0.96
230 (218 ... 243)	–	–	–	0.290	0.320	0.43
400 (380 ... 431)	–	–	–	0.165	0.190	0.24
460 (432 ... 484)	–	–	–	0.150	0.170	0.22

- I_B Accelerator current - brief inrush current
- I_H Holding current r.m.s. value in the supply cable to the SEW brake rectifier
- V_N Rated voltage (rated voltage range)



10 Appendix

10.1 Crimping tools

An alternative for purchasing the prefabricated cables from SEW-EURODRIVE for motors with plug connectors is to purchase the required plug connectors.

In this case, the customers have to wire the plug connectors themselves. SEW-EURODRIVE offers the matching crimping tools to ensure correct connection of cable core and contact. Please quote the required part number in your order.

10.1.1 Crimping tool for DFS56 power and brake contacts

Required tools for cable assembly

Type	SEW part number	Contact cross section Core cross section		Figure
		Power	Brake	
Crimping tool	0192430	–	–	
Positioning tool	0192457	∅ 2 mm 0.5 ... 2 mm ²	–	
	0192449	–	∅ 1 mm 0.06 ... 1 mm ²	

Required tools for disassembling the plug connector on the motor end

Type	SEW part number	Contact cross section	
		Power	Brake
Removal tool	0192473	∅ 2 mm	–
	0192465	–	∅ 1 mm



10.1.2 Crimping tool for CFM.. power and brake contacts

Required tools for cable assembly

For the following tool, different crimping jaws are required for assembling/disassembling different cross sections.

Type	SEW part number	Contact cross section Core cross section		Figure
		Power	Brake	
Crimping tool	0190705	∅ 3.6 mm	∅ 1.6 mm	
		0.5 ... 6.0 mm ²		
Crimping jaws	0190861	–	∅ 1.6 mm 0.5 ... 1.5 mm ²	
Contact receptacle	019087X	–		
Crimping jaws	0190128	∅ 3.6 mm	–	
Contact receptacle	0190144	1.5 ... 2.5 mm ²	–	
Crimping jaws	0190136	∅ 3.6 mm	–	
Contact receptacle	0190152	4.0 ... 6.0 mm ²	–	
Crimping tool	0190691	∅ 3.6 mm 1.5 ... 10 mm ²	–	
Positioning tool	0190713			
Test probe set	0190853			

Required tools for disassembling the plug connector on the motor end

No special tools are required for disassembly.

10.1.3 Crimping tool for encoder system/feedback system
Required tools for cable assembly

Product	Type	SEW part number	Contact cross section Core cross section Signal	Figure
RH1M(L) resolver HIPERFACE® • AS1H Multi-Turn • ES1H Single-Turn	Crimping tool	0192430	–	
	Positioning tool	0192449	∅ 1 mm 0.06 ... 1 mm ²	
SSI Multi-Turn	Crimping tool	0192597	–	
	Positioning tool	0192600	∅ 1 mm 0.24 ... 1 mm ²	

Required tools for disassembling the plug connector on the motor end

Product	Type	SEW part number	Contact cross section Core cross section Signal
RH1M(L) resolver HIPERFACE® • AS1H Multi-Turn • ES1H Single-Turn	Removal tool	0192481	Insulator
SSI Multi-Turn	No special tools are required for disassembly.		



10.2 SM11/SB11 power connector assembly (for DFS56 servomotor)

10.2.1 SM11/SB11 power connectors – scope of delivery

The following parts are supplied for assembling the power connectors. The SEW part number is 198 6740 or 0198 9197.

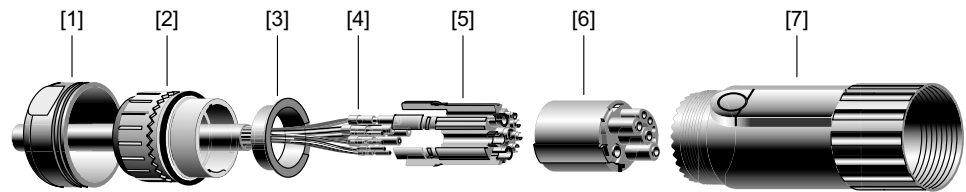

480295819

- [1] Screw fitting
- [2] Cable clamping
- [3] Clamping ring
- [4] Socket contacts
- [5] Insulating sleeve
- [6] Insulator
- [7] Connector housing



10.2.2 SM11/SB11 power connectors – assembly notes

	NOTICE
	<p>The power connector can be damaged if it is not assembled correctly. Potential damage to property.</p> <ul style="list-style-type: none"> Do not twist the cable during assembly.

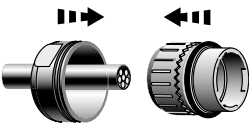
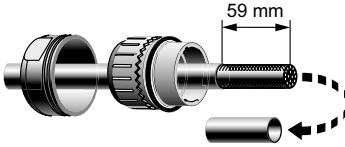
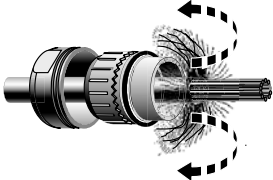
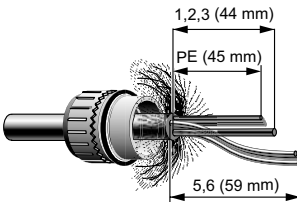
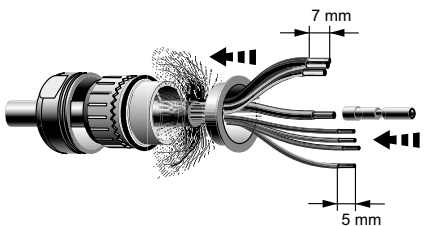
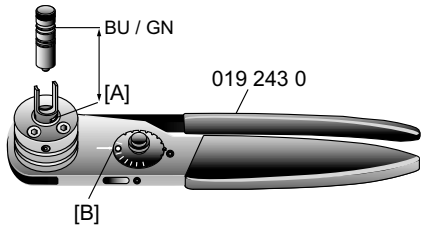
Step	Illustration	Procedure															
1		<ul style="list-style-type: none"> Pull the screw fitting and cable clamping over the cable. 															
2		<ul style="list-style-type: none"> Strip 59 mm of cable insulation off the end of the cable. 															
3		<ul style="list-style-type: none"> Fold back the braided shield and fan it out. 															
4		<ul style="list-style-type: none"> Shorten the power leads (1, 2 and 3) to 44 mm. Shorten the PE lead (GN/YE) to 45 mm. Do not shorten lead pair 5 and 6. Cut off lead pair 7 and 8 flush with the end of the cable. 															
5		<ul style="list-style-type: none"> Pull the clamping ring over the leads. Strip 7 mm of insulation off leads 1, 2, 3 and PE. Strip 5 mm of insulation of leads 5 and 6. 															
6		<ul style="list-style-type: none"> Insert the positioning tool in the crimping tool until the marking (color) appears in the view window [A] appears (see table below). Set the pressing force [B] on the crimping tool according to the table. 															
		<table border="1" style="width: 100%; border-collapse: collapse;"> <thead> <tr> <th style="text-align: center;">Lead</th> <th style="text-align: center;">a [mm²]</th> <th style="text-align: center;">Positioning tool Part number</th> <th style="text-align: center;">Marking (color)</th> <th style="text-align: center;">Press force</th> </tr> </thead> <tbody> <tr> <td style="text-align: center;">5 and 6</td> <td style="text-align: center;">0.14 ... 1.0</td> <td style="text-align: center;">019 244 9</td> <td style="text-align: center;">Green (GN)</td> <td style="text-align: center;">24</td> </tr> <tr> <td style="text-align: center;">1, 2, 3 and PE</td> <td style="text-align: center;">0.35 ... 4.0</td> <td style="text-align: center;">019 245 7</td> <td style="text-align: center;">Blue (BU)</td> <td style="text-align: center;">6</td> </tr> </tbody> </table>	Lead	a [mm ²]	Positioning tool Part number	Marking (color)	Press force	5 and 6	0.14 ... 1.0	019 244 9	Green (GN)	24	1, 2, 3 and PE	0.35 ... 4.0	019 245 7	Blue (BU)	6
Lead	a [mm ²]	Positioning tool Part number	Marking (color)	Press force													
5 and 6	0.14 ... 1.0	019 244 9	Green (GN)	24													
1, 2, 3 and PE	0.35 ... 4.0	019 245 7	Blue (BU)	6													



Step	Illustration	Procedure
7		<ul style="list-style-type: none"> • Insert a lead with socket contact in the crimping tool and press the tool fully together. The tool then opens automatically. • Repeat this procedure for each lead in accordance with the table in step 6.
8		<ul style="list-style-type: none"> • Open the insulating sleeve.
9		<ul style="list-style-type: none"> • Insert the middle socket contact into the insulator according to the wiring diagram. • Close the insulating sleeve until it clicks shut. • Insert the remaining socket contacts into the insulator according to the wiring diagram.
10		<ul style="list-style-type: none"> • Shorten the braided shield as shown. • Insert the shield ring into the seal so that the shield and end of the cable are flush. Make sure that the braided shield is routed cleanly between the shield ring and the seal.
11		<ul style="list-style-type: none"> • Insert the insulator into the connector housing until the seal rests against its stop in the connector housing.
12		<ul style="list-style-type: none"> • Use a wrench to hold the connector housing in place and use a second wrench to tighten the screw fitting. • [A] = Hold in place



10.3 Assembly of SM5./SM6. and SB5./SB6. power connectors

	TIP
	For SM5./SM6., step 4.3. is not necessary.

Ø	a	b
8 - 17 mm	43 mm	54 mm
7 - 23 mm	52 mm	63 mm

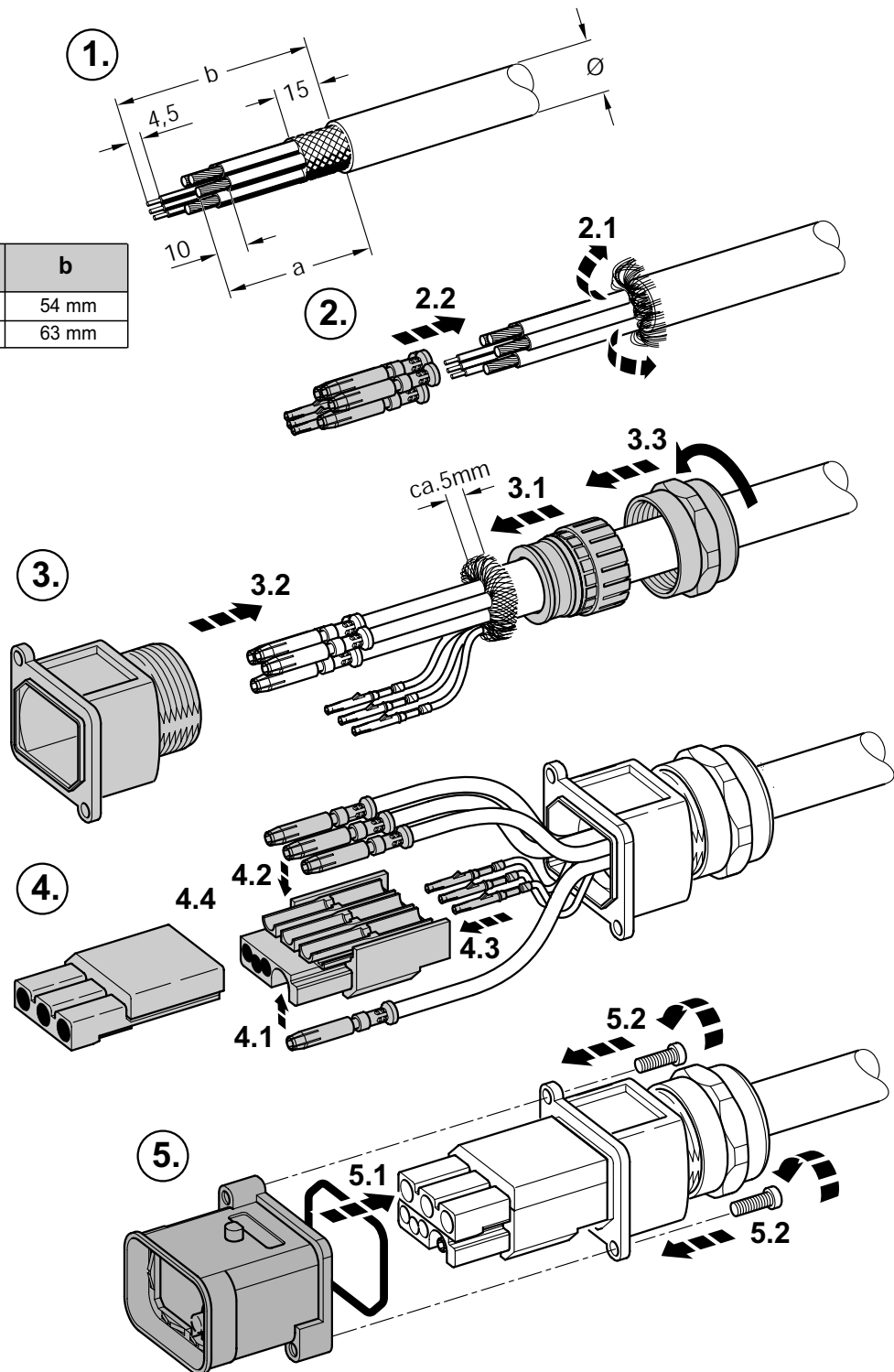

480479371



10.4 Assembly of signal plug connectors (resolver/HIPERFACE®)

10.4.1 Scope of delivery for signal plug connectors (resolver/HIPERFACE®)

The following parts are supplied for assembling the signal plug connectors.

The SEW part number is 198 673 2.

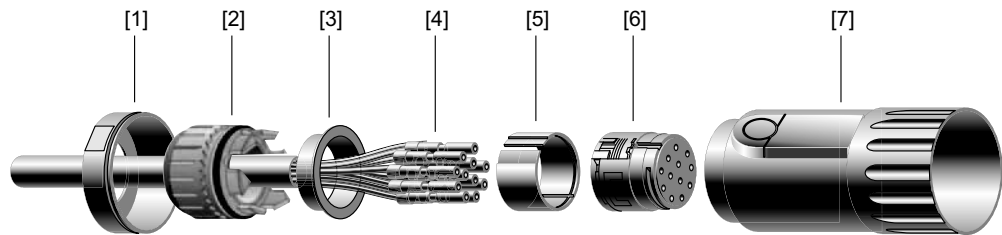

551857419

- [1] Screw fitting
- [2] Cable clamping
- [3] Clamping ring
- [4] Socket contacts
- [5] Insulating sleeve
- [6] Insulator
- [7] Connector housing



10.4.2 Assembly notes for signal plug connectors (resolver/HIPERFACE®)

NOTICE	
	<p>The signal plug connector can be damaged if it is not assembled correctly. Potential damage to property.</p> <ul style="list-style-type: none"> Do not twist the cable during assembly.

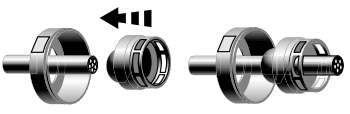
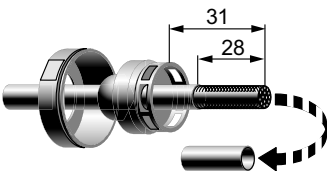
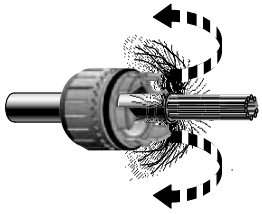
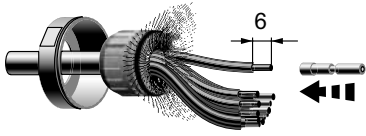
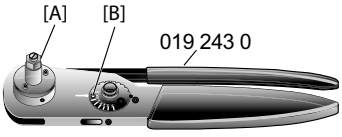
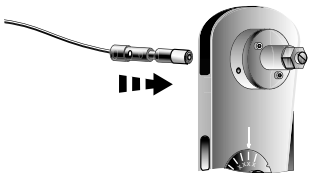
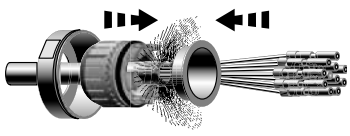
Step	Illustration	Procedure
1		<ul style="list-style-type: none"> Pull the screw fitting and cable clamping with strain relief 31 mm over the cable.
2		<ul style="list-style-type: none"> Strip 28 mm of cable insulation off the end of the cable.
3		<ul style="list-style-type: none"> Fold back the braided shield and fan it out.
4		<ul style="list-style-type: none"> Strip 6 mm insulation off the leads. Push the socket contacts onto the ends of the leads.
5		<ul style="list-style-type: none"> Insert the small-diameter positioning tool (SEW part number 019 244 9) into the crimping tool until the green mark appears in the view window [A]. Set the pressing force [B] to 24 on the crimping tool.
6		<ul style="list-style-type: none"> Insert a lead with socket contact in the crimping tool and press the tool fully together. The tool then opens automatically. Repeat this procedure for each lead.
7		<ul style="list-style-type: none"> Pull the clamping ring over the leads and press the shield against the seal.

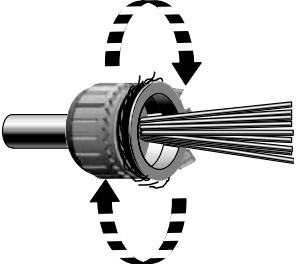
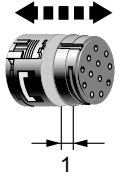
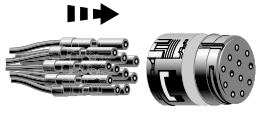
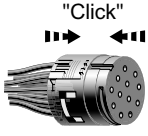
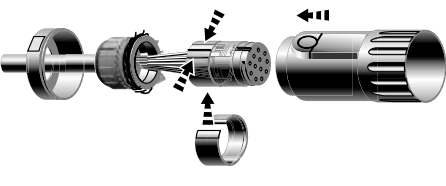
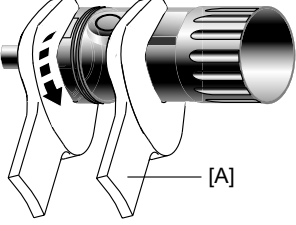
Step	Illustration	Procedure
8		<ul style="list-style-type: none"> Turn the clamping ring until the braided shield is flush with the shield ring.
9		<ul style="list-style-type: none"> Pull the insulator apart evenly by about 1 mm.
10		<ul style="list-style-type: none"> Insert the socket contacts into the insulator according to the wiring diagrams.
11		<ul style="list-style-type: none"> Press the insulator together until you hear a click.
12		<ul style="list-style-type: none"> Fold open the insulating sleeve. Position the side of the insulating sleeve with the recess against the groove in the insulator so that the opening of the insulating sleeve is pointing in the same direction as the double-headed arrow on the insulator. Press the insulating sleeve together until it engages. Insert the insulator into the connector housing in the middle position.
13		<ul style="list-style-type: none"> Use a wrench to hold the connector housing in place and use a second wrench to tighten the screw fitting. [A] = Hold in place





10.5 Wiring diagrams for DFS/CFM synchronous servomotors

The following applies to all wiring diagrams:

- View on wiring side
- Colors according to SEW-EURODRIVE cable:

Color code	Color
BK	Black
BN	Brown
BU	Blue
GN	Green
GY	Gray
OG	Orange
PK	Pink
RD	Red
VT	Violet
WH	White
YE	Yellow
GY/PK	Gray/pink
RD/BU	Red/blue
BK/WH	Black/white
RD/WH	Red/white

10.5.1 Symbols used

	Plug connector upper part (to be connected by the customer)
	Plug connector lower part (connected at the factory)



10.6 Wiring diagram for CFM motors with power connector

10.6.1 Wiring diagram with/without brake

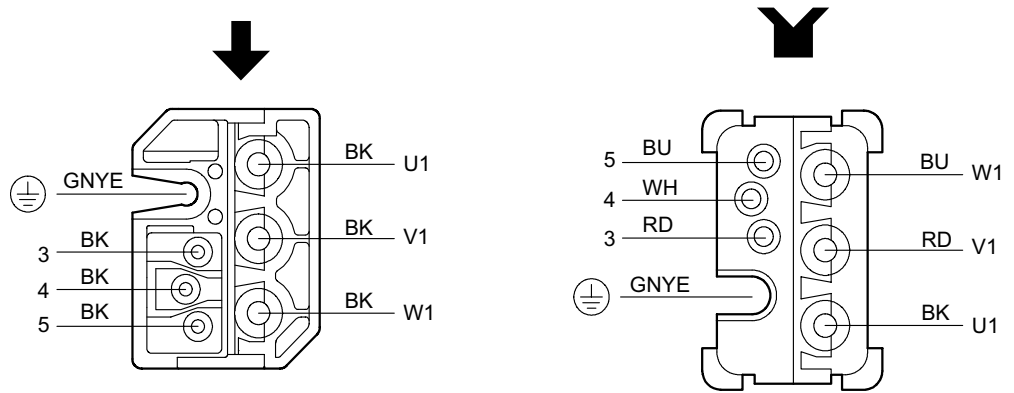

480858251

10.7 Wiring diagram for CFM motors with signal connector

10.7.1 Wiring diagram for RH.M/RH.L resolver

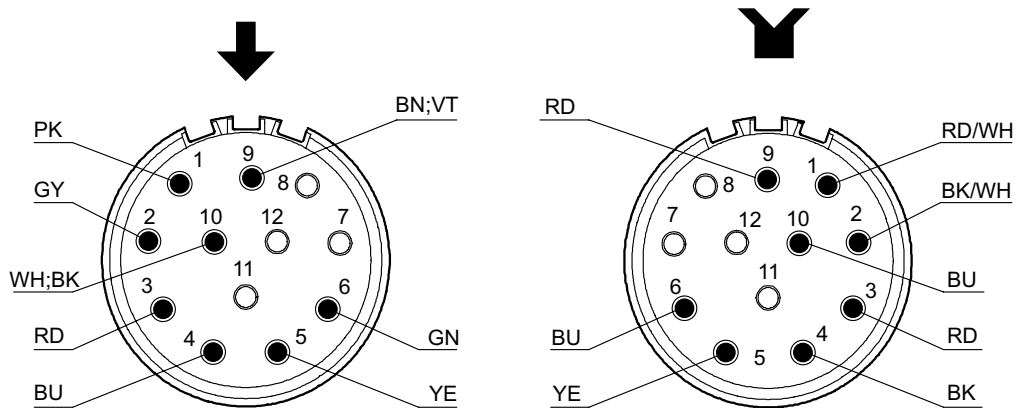

634292235

Contact assignment of plug connector lower part

Pin	Color code	Connection
1	RD/WH	R1 (reference +)
2	BK/WH	R2 (reference -)
3	RD	S1 (cosine +)
4	BK	S3 (cosine -)
5	YE	S2 (sine +)
6	BU	S4 (sine -)
7	-	-
8	-	-
9	RD	TF/KTY +
10	BU	TF/KTY-
11	-	-
12	-	-



10.7.2 Wiring diagram for ES1H, AS1H encoder

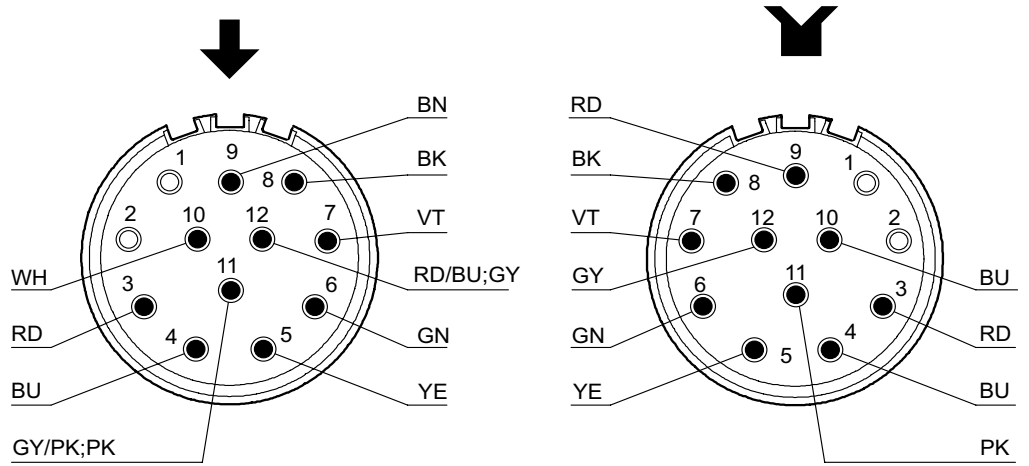

480856715

Contact assignment of plug connector lower part

Pin	Color code	Connection
1	-	-
2	-	-
3	RD	S1 (cosine +)
4	BU	S3 (cosine -)
5	YE	S2 (sine +)
6	GN	S4 (sine -)
7	VT	D-
8	BK	D+
9	RD	TF/KTY +
10	BU	TF/KTY-
11	PK	Voltage reference (GND)
12	GY	Supply voltage Vs



10.8 Wiring diagram for CFM motors with terminal box

10.8.1 Wiring diagram with/without brake

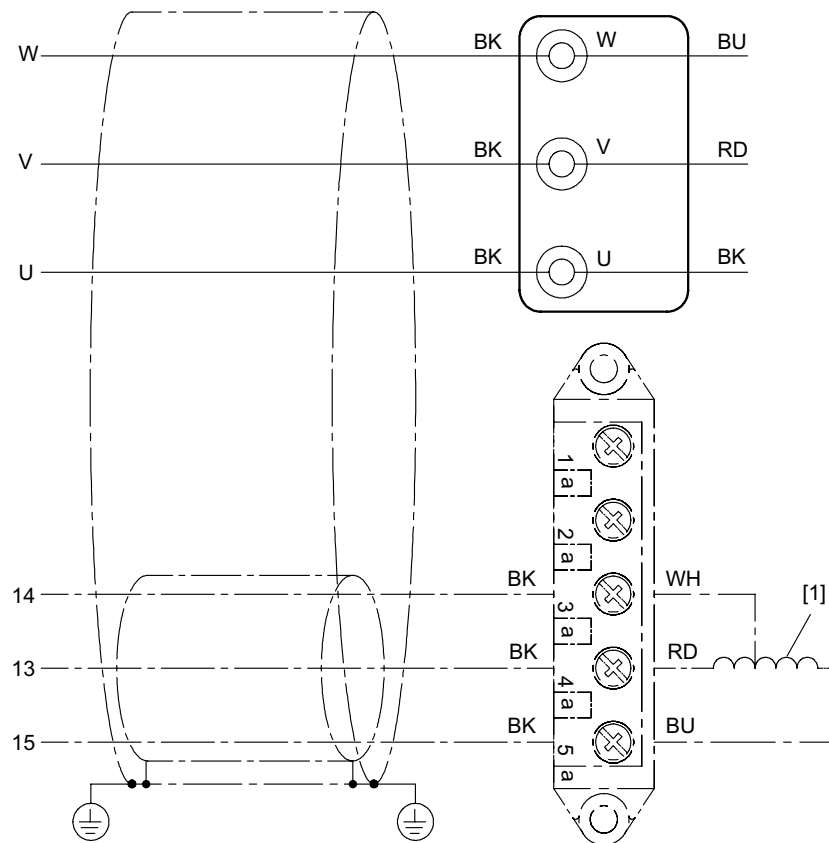

480859787

[1] Brake coil



10.8.2 Wiring diagram for RH1M/RH1L resolver

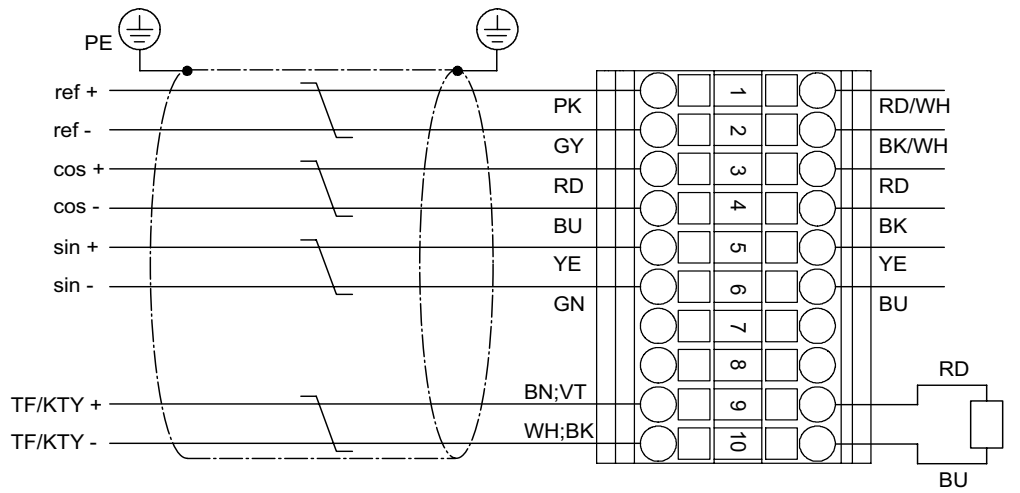

480862859

10.8.3 Wiring diagram for ES1H/AS1H encoder

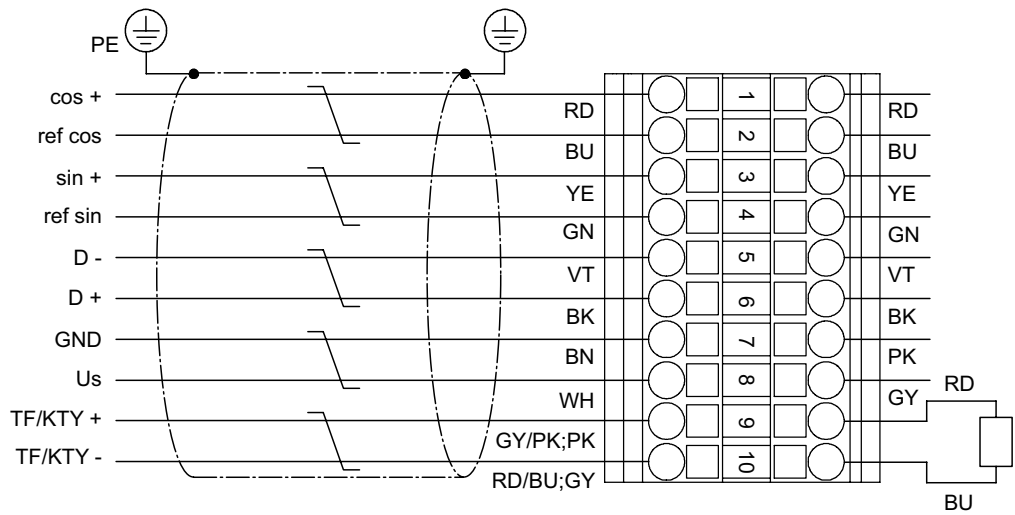

480864395



10.9 Wiring diagram for DFS motors with power connector

10.9.1 Wiring diagram with/without brake

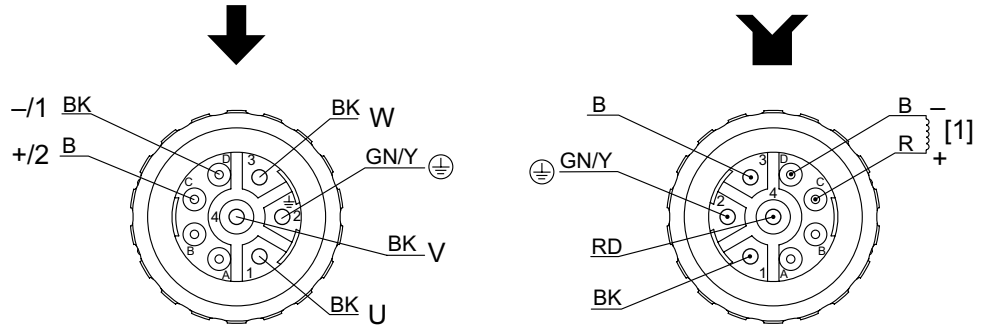

634537611

[1] Brake coil

10.10 Wiring diagram for DFS motors with signal connector

10.10.1 Wiring diagram for RH1M resolver

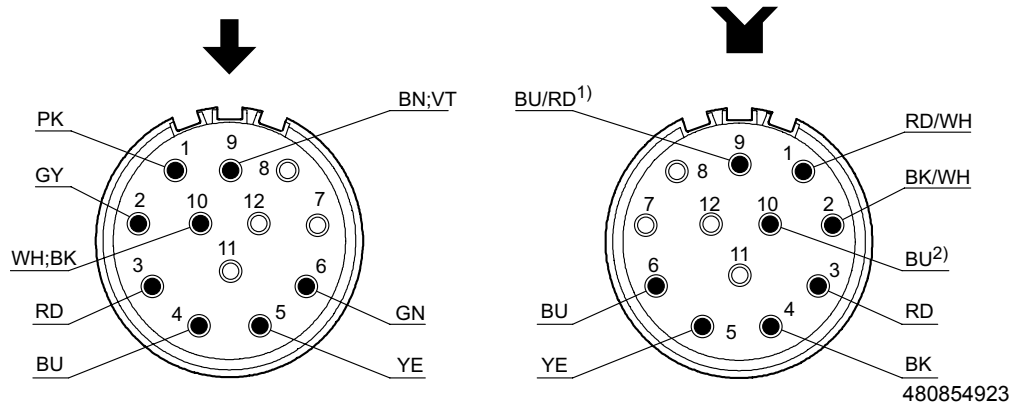

480854923

Contact assignment of plug connector lower part

Pin	Color code	Connection
1	RD/WH	R1 (reference +)
2	BK/WH	R2 (reference -)
3	RD	S1 (cosine +)
4	BK	S3 (cosine -)
5	YE	S2 (sine +)
6	BU	S4 (sine -)
7	-	-
8	-	-
9	BU/RD ¹⁾	TF/KTY +
10	BU ²⁾	TF/KTY-
11	-	-
12	-	-

1) TF = BU; KTY+ = RD

2) TF = BU; KTY- = BU



10.10.2 Wiring diagram for ES1H, AS1H encoder

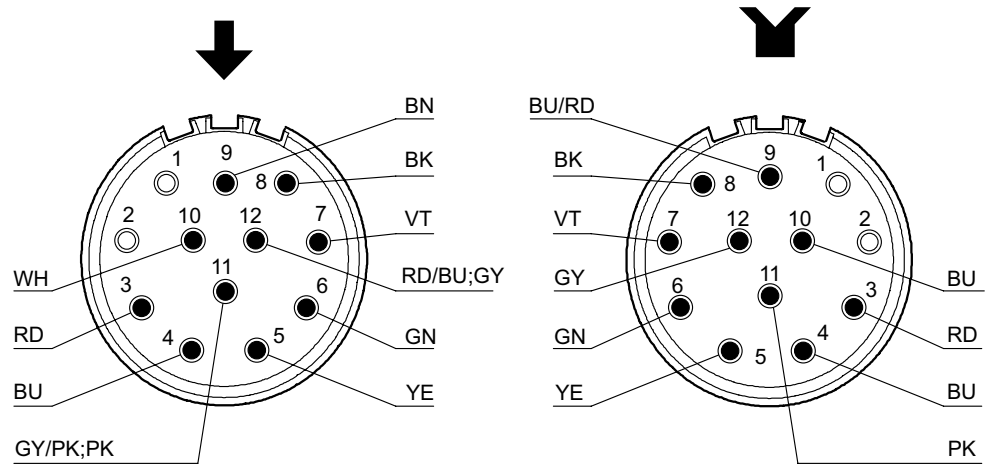

634478731

Contact assign-
ment of plug con-
nector lower part

Pin	Color code	Connection
1	-	-
2	-	-
3	RD	S1 (cosine +)
4	BU	S3 (cosine -)
5	YE	S2 (sine +)
6	GN	S4 (sine -)
7	VT	D-
8	BK	D+
9	BU	TF
	RD	KTY +
10	BU	TF/KTY-
11	PY	Voltage reference (GND)
12	GY	Supply voltage Vs



10.11 Wiring diagram for DFS motors with terminal box

10.11.1 Wiring diagram for RH1M/RH1L resolver with/without brake

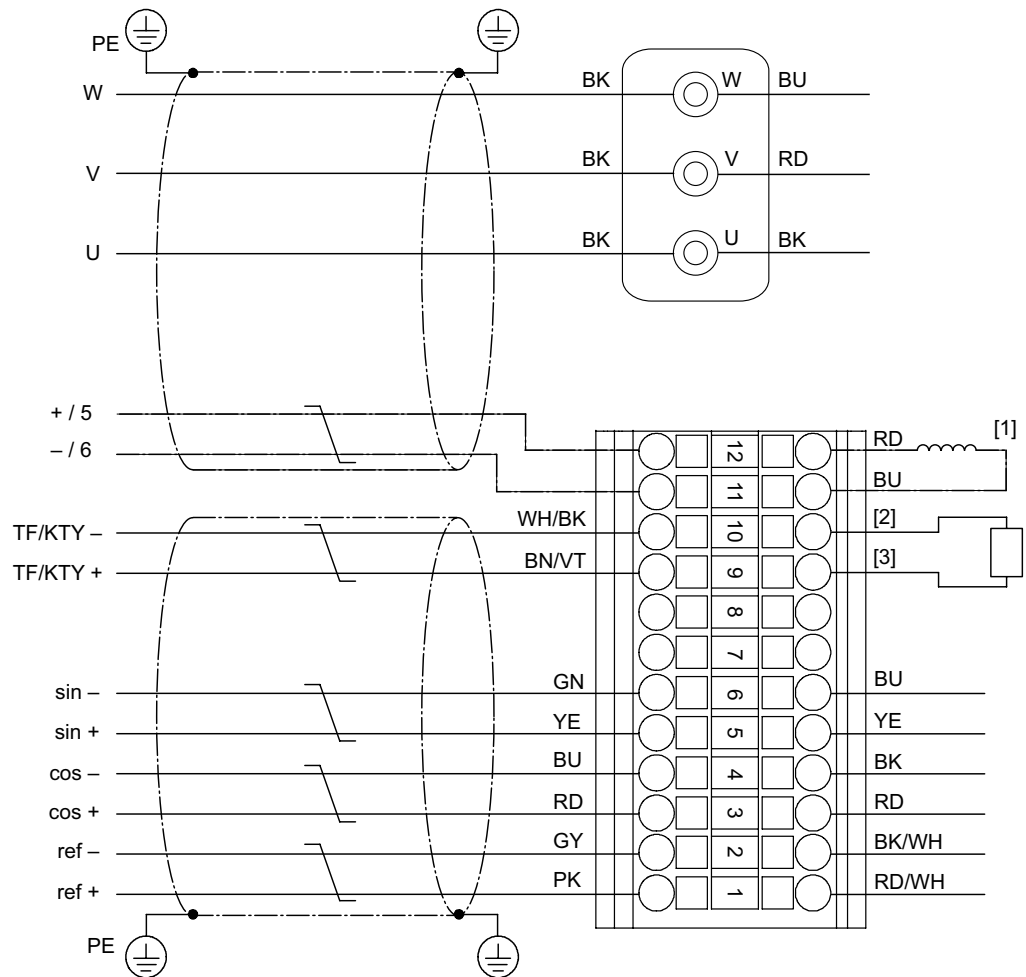

641092491

- [1] Brake coil
- [2] TF = BU; KTY - = BU
- [3] TF = BU; KTY+ = RD



10.11.2 Wiring diagram for ES1H/AS1H encoder with/without brake

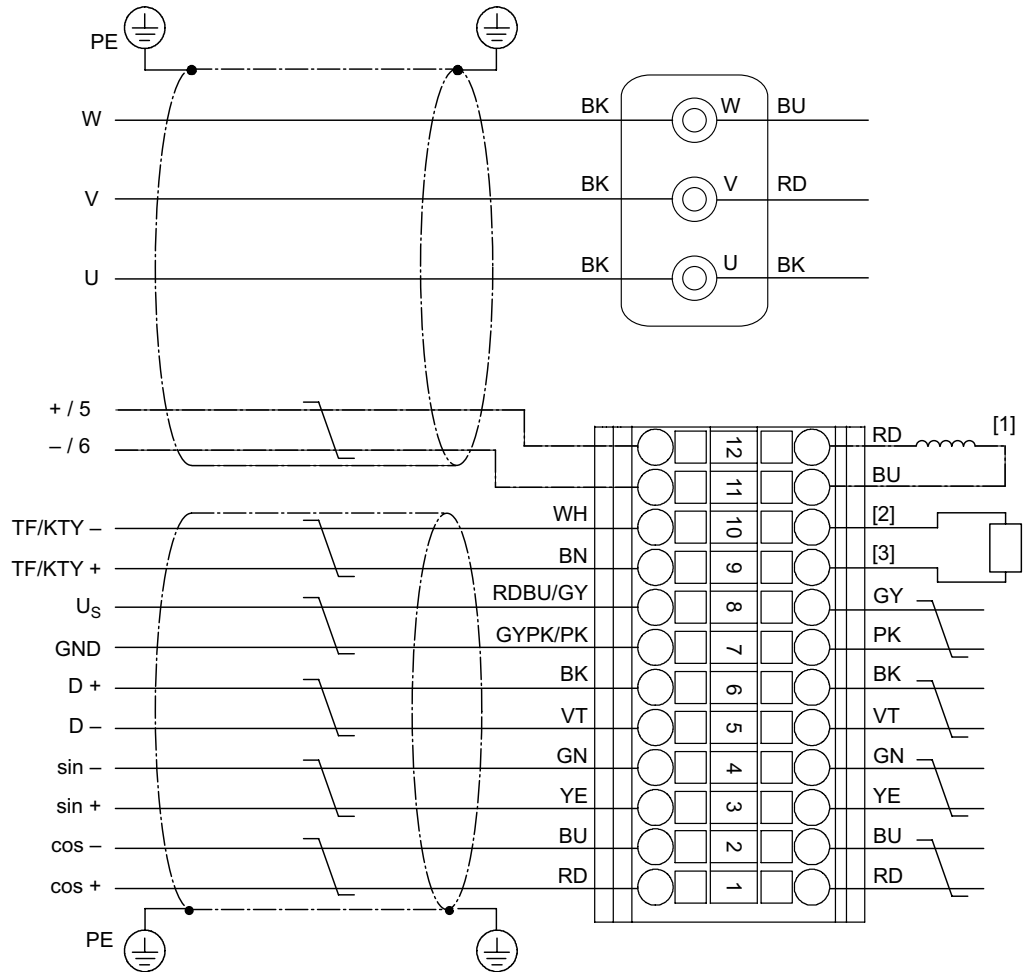

641149579

- [1] Brake coil
- [2] TF = BU; KTY - = BU
- [3] TF = BU; KTY+ = RD



10.12 Wiring diagram for VR forced cooling fan

10.12.1 DC 24 V supply voltage

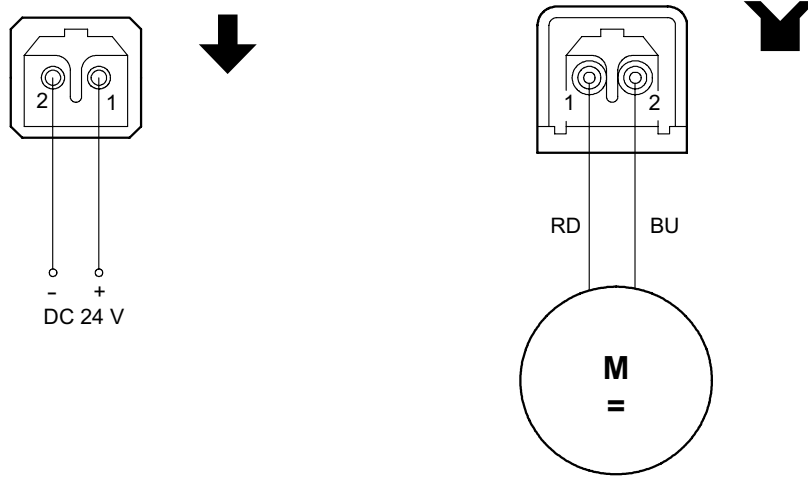

480865931

10.12.2 Connection with UWU52A power supply unit

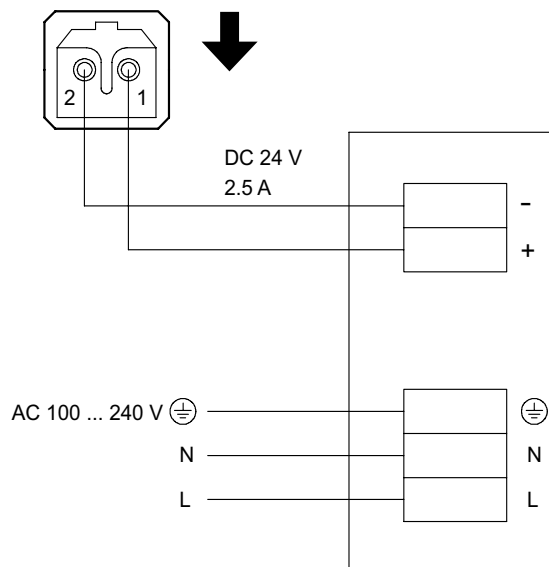

480880651



NOTICE

Improper connection may damage the forced-cooling fan.
Potential damage to property.

- Observe the polarity.



11 Address List

Germany				
Headquarters Production Sales	Bruchsal	SEW-EURODRIVE GmbH & Co KG Ernst-Blickle-Straße 42 D-76646 Bruchsal P.O. Box Postfach 3023 • D-76642 Bruchsal	Tel. +49 7251 75-0 Fax +49 7251 75-1970 http://www.sew-eurodrive.de sew@sew-eurodrive.de	
Service Competence Center	Central	SEW-EURODRIVE GmbH & Co KG Ernst-Blickle-Straße 1 D-76676 Graben-Neudorf	Tel. +49 7251 75-1710 Fax +49 7251 75-1711 sc-mitte@sew-eurodrive.de	
	North	SEW-EURODRIVE GmbH & Co KG Alte Ricklinger Straße 40-42 D-30823 Garbsen (near Hannover)	Tel. +49 5137 8798-30 Fax +49 5137 8798-55 sc-nord@sew-eurodrive.de	
	East	SEW-EURODRIVE GmbH & Co KG Dänkritzter Weg 1 D-08393 Meerane (near Zwickau)	Tel. +49 3764 7606-0 Fax +49 3764 7606-30 sc-ost@sew-eurodrive.de	
	South	SEW-EURODRIVE GmbH & Co KG Domagkstraße 5 D-85551 Kirchheim (near München)	Tel. +49 89 909552-10 Fax +49 89 909552-50 sc-sued@sew-eurodrive.de	
	West	SEW-EURODRIVE GmbH & Co KG Siemensstraße 1 D-40764 Langenfeld (near Düsseldorf)	Tel. +49 2173 8507-30 Fax +49 2173 8507-55 sc-west@sew-eurodrive.de	
	Electronics	SEW-EURODRIVE GmbH & Co KG Ernst-Blickle-Straße 42 D-76646 Bruchsal	Tel. +49 7251 75-1780 Fax +49 7251 75-1769 sc-elektronik@sew-eurodrive.de	
	Drive Service Hotline / 24 Hour Service		+49 180 5 SEWHELP +49 180 5 7394357	
	Additional addresses for service in Germany provided on request!			
France				
Production Sales Service	Hagenau	SEW-USOCOME 48-54, route de Soufflenheim B. P. 20185 F-67506 Hagenau Cedex	Tel. +33 3 88 73 67 00 Fax +33 3 88 73 66 00 http://www.usocomme.com sew@usocomme.com	
Production	Forbach	SEW-EUROCOME Zone Industrielle Technopôle Forbach Sud B. P. 30269 F-57604 Forbach Cedex	Tel. +33 3 87 29 38 00	
Assembly Sales Service	Bordeaux	SEW-USOCOME Parc d'activités de Magellan 62, avenue de Magellan - B. P. 182 F-33607 Pessac Cedex	Tel. +33 5 57 26 39 00 Fax +33 5 57 26 39 09	
	Lyon	SEW-USOCOME Parc d'Affaires Roosevelt Rue Jacques Tati F-69120 Vaulx en Velin	Tel. +33 4 72 15 37 00 Fax +33 4 72 15 37 15	
	Paris	SEW-USOCOME Zone industrielle 2, rue Denis Papin F-77390 Verneuil l'Etang	Tel. +33 1 64 42 40 80 Fax +33 1 64 42 40 88	
Additional addresses for service in France provided on request!				



Algeria			
Sales	Alger	Réducom 16, rue des Frères Zagnoun Bellevue El-Harrach 16200 Alger	Tel. +213 21 8222-84 Fax +213 21 8222-84 reducom_sew@yahoo.fr
Argentina			
Assembly Sales Service	Buenos Aires	SEW EURODRIVE ARGENTINA S.A. Centro Industrial Garin, Lote 35 Ruta Panamericana Km 37,5 1619 Garin	Tel. +54 3327 4572-84 Fax +54 3327 4572-21 sewar@sew-eurodrive.com.ar http://www.sew-eurodrive.com.ar
Australia			
Assembly Sales Service	Melbourne	SEW-EURODRIVE PTY. LTD. 27 Beverage Drive Tullamarine, Victoria 3043	Tel. +61 3 9933-1000 Fax +61 3 9933-1003 http://www.sew-eurodrive.com.au enquires@sew-eurodrive.com.au
	Sydney	SEW-EURODRIVE PTY. LTD. 9, Sleigh Place, Wetherill Park New South Wales, 2164	Tel. +61 2 9725-9900 Fax +61 2 9725-9905 enquires@sew-eurodrive.com.au
Austria			
Assembly Sales Service	Wien	SEW-EURODRIVE Ges.m.b.H. Richard-Strauss-Strasse 24 A-1230 Wien	Tel. +43 1 617 55 00-0 Fax +43 1 617 55 00-30 http://sew-eurodrive.at sew@sew-eurodrive.at
Belarus			
Sales	Minsk	SEW-EURODRIVE BY RybalkoStr. 26 BY-220033 Minsk	Tel. +375 (17) 298 38 50 Fax +375 (17) 29838 50 sales@sew.by
Belgium			
Assembly Sales Service	Brüssel	SEW Caron-Vector Avenue Eiffel 5 B-1300 Wavre	Tel. +32 10 231-311 Fax +32 10 231-336 http://www.sew-eurodrive.be info@caron-vector.be
Service Competence Center	Industrial Gears	SEW Caron-Vector Rue de Parc Industriel, 31 BE-6900 Marche-en-Famenne	Tel. +32 84 219-878 Fax +32 84 219-879 http://www.sew-eurodrive.be service-wallonie@sew-eurodrive.be
	Antwerp	SEW Caron-Vector Glasstraat, 19 BE-2170 Merksem	Tel. +32 3 64 19 333 Fax +32 3 64 19 336 http://www.sew-eurodrive.be service-antwerpen@sew-eurodrive.be
Brazil			
Production Sales Service	Sao Paulo	SEW-EURODRIVE Brasil Ltda. Avenida Amâncio Gaiolli, 152 - Rodovia Presidente Dutra Km 208 Guarulhos - 07251-250 - SP SAT - SEW ATENDE - 0800 7700496	Tel. +55 11 2489-9133 Fax +55 11 2480-3328 http://www.sew-eurodrive.com.br sew@sew.com.br
Additional addresses for service in Brazil provided on request!			
Bulgaria			
Sales	Sofia	BEVER-DRIVE GmbH Bogdanovetz Str.1 BG-1606 Sofia	Tel. +359 2 9151160 Fax +359 2 9151166 bever@fastbg.net



Cameroon			
Sales	Douala	Electro-Services Rue Drouot Akwa B.P. 2024 Douala	Tel. +237 33 431137 Fax +237 33 431137
Canada			
Assembly Sales Service	Toronto	SEW-EURODRIVE CO. OF CANADA LTD. 210 Walker Drive Bramalea, Ontario L6T3W1	Tel. +1 905 791-1553 Fax +1 905 791-2999 http://www.sew-eurodrive.ca marketing@sew-eurodrive.ca
	Vancouver	SEW-EURODRIVE CO. OF CANADA LTD. 7188 Honeyman Street Delta. B.C. V4G 1 E2	Tel. +1 604 946-5535 Fax +1 604 946-2513 marketing@sew-eurodrive.ca
	Montreal	SEW-EURODRIVE CO. OF CANADA LTD. 2555 Rue Leger LaSalle, Quebec H8N 2V9	Tel. +1 514 367-1124 Fax +1 514 367-3677 marketing@sew-eurodrive.ca
Additional addresses for service in Canada provided on request!			
Chile			
Assembly Sales Service	Santiago de Chile	SEW-EURODRIVE CHILE LTDA. Las Encinas 1295 Parque Industrial Valle Grande LAMP RCH-Santiago de Chile P.O. Box Casilla 23 Correo Quilicura - Santiago - Chile	Tel. +56 2 75770-00 Fax +56 2 75770-01 http://www.sew-eurodrive.cl ventas@sew-eurodrive.cl
China			
Production Assembly Sales Service	Tianjin	SEW-EURODRIVE (Tianjin) Co., Ltd. No. 46, 7th Avenue, TEDA Tianjin 300457	Tel. +86 22 25322612 Fax +86 22 25322611 info@sew-eurodrive.cn http://www.sew-eurodrive.cn
Assembly Sales Service	Suzhou	SEW-EURODRIVE (Suzhou) Co., Ltd. 333, Suhong Middle Road Suzhou Industrial Park Jiangsu Province, 215021	Tel. +86 512 62581781 Fax +86 512 62581783 suzhou@sew-eurodrive.cn
	Guangzhou	SEW-EURODRIVE (Guangzhou) Co., Ltd. No. 9, JunDa Road East Section of GETDD Guangzhou 510530	Tel. +86 20 82267890 Fax +86 20 82267891 guangzhou@sew-eurodrive.cn
	Shenyang	SEW-EURODRIVE (Shenyang) Co., Ltd. 10A-2, 6th Road Shenyang Economic Technological Development Area Shenyang, 110141	Tel. +86 24 25382538 Fax +86 24 25382580 shenyang@sew-eurodrive.cn
	Wuhan	SEW-EURODRIVE (Wuhan) Co., Ltd. 10A-2, 6th Road No. 59, the 4th Quanli Road, WEDA 430056 Wuhan	Tel. +86 27 84478398 Fax +86 27 84478388
Additional addresses for service in China provided on request!			
Colombia			
Assembly Sales Service	Bogotá	SEW-EURODRIVE COLOMBIA LTDA. Calle 22 No. 132-60 Bodega 6, Manzana B Santafé de Bogotá	Tel. +57 1 54750-50 Fax +57 1 54750-44 http://www.sew-eurodrive.com.co carlos.gomez@sew.eurodrive.com.co



Croatia			
Sales Service	Zagreb	KOMPEKS d. o. o. PIT Erdödy 4 II HR 10 000 Zagreb	Tel. +385 1 4613-158 Fax +385 1 4613-158 kompeks@inet.hr
Czech Republic			
Sales	Praha	SEW-EURODRIVE CZ S.R.O. Business Centrum Praha Lužná 591 CZ-16000 Praha 6 - Vokovice	Tel. +420 255 709 601 Fax +420 220 121 237 http://www.sew-eurodrive.cz sew@sew-eurodrive.cz
Denmark			
Assembly Sales Service	Kopenhagen	SEW-EURODRIVEA/S Geminivej 28-30 DK-2670 Greve	Tel. +45 43 9585-00 Fax +45 43 9585-09 http://www.sew-eurodrive.dk sew@sew-eurodrive.dk
Egypt			
Sales Service	Cairo	Copam Egypt for Engineering & Agencies 33 El Hegaz ST, Heliopolis, Cairo	Tel. +20 2 22566-299 + 1 23143088 Fax +20 2 22594-757 http://www.copam-egypt.com/ copam@datum.com.eg
Estonia			
Sales	Tallin	ALAS-KUUL AS Reti tee 4 EE-75301 Peetri küla, Rae vald, Harjumaa	Tel. +372 6593230 Fax +372 6593231 veiko.soots@alas-kuul.ee
Finland			
Assembly Sales Service	Lahti	SEW-EURODRIVE OY Vesimäentie 4 FIN-15860 Hollola 2	Tel. +358 201 589-300 Fax +358 3 780-6211 sew@sew.fi http://www.sew-eurodrive.fi
Production Assembly Service	Karkkila	SEW Industrial Gears Oy Valurinkatu 6 FIN-03600 Karkkila	Tel. +358 201 589-300 Fax +358 201 589-310 sew@sew.fi http://www.sew-eurodrive.fi
Gabon			
Sales	Libreville	Electro-Services B.P. 1889 Libreville	Tel. +241 7340-11 Fax +241 7340-12
Great Britain			
Assembly Sales Service	Normanton	SEW-EURODRIVE Ltd. Beckbridge Industrial Estate P.O. Box No.1 GB-Normanton, West- Yorkshire WF6 1QR	Tel. +44 1924 893-855 Fax +44 1924 893-702 http://www.sew-eurodrive.co.uk info@sew-eurodrive.co.uk
Greece			
Sales Service	Athen	Christ. Boznos & Son S.A. 12, Mavromichali Street P.O. Box 80136, GR-18545 Piraeus	Tel. +30 2 1042 251-34 Fax +30 2 1042 251-59 http://www.boznos.gr info@boznos.gr



Hong Kong			
Assembly	Hong Kong	SEW-EURODRIVE LTD.	Tel. +852 36902200
Sales		Unit No. 801-806, 8th Floor	Fax +852 36902211
Service		Hong Leong Industrial Complex No. 4, Wang Kwong Road Kowloon, Hong Kong	contact@sew-eurodrive.hk
Hungary			
Sales	Budapest	SEW-EURODRIVE Kft.	Tel. +36 1 437 06-58
Service		H-1037 Budapest Kunigunda u. 18	Fax +36 1 437 06-50 office@sew-eurodrive.hu
India			
Assembly	Vadodara	SEW-EURODRIVE India Private Limited	Tel. +91 265 2831086
Sales		Plot No. 4, GIDC	Fax +91 265 2831087
Service		POR Ramangamdi • Vadodara - 391 243 Gujarat	http://www.seweurodriveindia.com sales@seweurodriveindia.com subodh.ladwa@seweurodriveindia.com
Ireland			
Sales	Dublin	Alperon Engineering Ltd.	Tel. +353 1 830-6277
Service		48 Moyle Road Dublin Industrial Estate Glasnevin, Dublin 11	Fax +353 1 830-6458 info@alperon.ie http://www.alperon.ie
Israel			
Sales	Tel-Aviv	Liraz Handasa Ltd.	Tel. +972 3 5599511
		Ahofer Str 34B / 228 58858 Holon	Fax +972 3 5599512 http://www.liraz-handasa.co.il office@liraz-handasa.co.il
Italy			
Assembly	Milano	SEW-EURODRIVE di R. Blicke & Co.s.a.s.	Tel. +39 02 96 9801
Sales		Via Bernini,14	Fax +39 02 96 799781
Service		I-20020 Solaro (Milano)	http://www.sew-eurodrive.it sewit@sew-eurodrive.it
Ivory Coast			
Sales	Abidjan	SICA	Tel. +225 2579-44
		Ste industrielle et commerciale pour l'Afrique 165, Bld de Marseille B.P. 2323, Abidjan 08	Fax +225 2584-36
Japan			
Assembly	Iwata	SEW-EURODRIVE JAPAN CO., LTD	Tel. +81 538 373811
Sales		250-1, Shimoman-no,	Fax +81 538 373814
Service		Iwata Shizuoka 438-0818	http://www.sew-eurodrive.co.jp sewjapan@sew-eurodrive.co.jp
Korea			
Assembly	Ansan-City	SEW-EURODRIVE KOREA CO., LTD.	Tel. +82 31 492-8051
Sales		B 601-4, Banweol Industrial Estate	Fax +82 31 492-8056
Service		1048-4, Shingil-Dong Ansan 425-120	http://www.sew-korea.co.kr master@sew-korea.co.kr
	Busan	SEW-EURODRIVE KOREA Co., Ltd.	Tel. +82 51 832-0204
		No. 1720 - 11, Songjeong - dong Gangseo-ku Busan 618-270	Fax +82 51 832-0230 master@sew-korea.co.kr



Latvia			
Sales	Riga	SIA Alas-Kuul Katlakalna 11C LV-1073 Riga	Tel. +371 7139253 Fax +371 7139386 http://www.alas-kuul.com info@alas-kuul.com
Lebanon			
Sales	Beirut	Gabriel Acar & Fils sarl B. P. 80484 Bourj Hammoud, Beirut	Tel. +961 1 4947-86 +961 1 4982-72 +961 3 2745-39 Fax +961 1 4949-71 ssacar@inco.com.lb
Lithuania			
Sales	Alytus	UAB Irseva Naujoji 19 LT-62175 Alytus	Tel. +370 315 79204 Fax +370 315 56175 info@irseva.lt http://www.sew-eurodrive.lt
Luxembourg			
Assembly Sales Service	Brüssel	CARON-VECTOR S.A. Avenue Eiffel 5 B-1300 Wavre	Tel. +32 10 231-311 Fax +32 10 231-336 http://www.sew-eurodrive.lu info@caron-vector.be
Malaysia			
Assembly Sales Service	Johore	SEW-EURODRIVE SDN BHD No. 95, Jalan Seroja 39, Taman Johor Jaya 81000 Johor Bahru, Johor West Malaysia	Tel. +60 7 3549409 Fax +60 7 3541404 sales@sew-eurodrive.com.my
Mexico			
Assembly Sales Service	Quéretaro	SEW-EURODRIVE MEXICO SA DE CV SEM-981118-M93 Tequisquiapan No. 102 Parque Industrial Quéretaro C.P. 76220 Quéretaro, México	Tel. +52 442 1030-300 Fax +52 442 1030-301 http://www.sew-eurodrive.com.mx scmexico@seweurodrive.com.mx
Morocco			
Sales	Casablanca	Afit 5, rue Emir Abdelkader MA 20300 Casablanca	Tel. +212 22618372 Fax +212 22618351 ali.alami@premium.net.ma
Netherlands			
Assembly Sales Service	Rotterdam	VECTOR Aandrijftechniek B.V. Industrieweg 175 NL-3044 AS Rotterdam Postbus 10085 NL-3004 AB Rotterdam	Tel. +31 10 4463-700 Fax +31 10 4155-552 http://www.vector.nu info@vector.nu
New Zealand			
Assembly Sales Service	Auckland	SEW-EURODRIVE NEW ZEALAND LTD. P.O. Box 58-428 82 Greenmount drive East Tamaki Auckland	Tel. +64 9 2745627 Fax +64 9 2740165 http://www.sew-eurodrive.co.nz sales@sew-eurodrive.co.nz
	Christchurch	SEW-EURODRIVE NEW ZEALAND LTD. 10 Settlers Crescent, Ferrymead Christchurch	Tel. +64 3 384-6251 Fax +64 3 384-6455 sales@sew-eurodrive.co.nz



Norway			
Assembly	Moss	SEW-EURODRIVE A/S	Tel. +47 69 24 10 20
Sales		Solgaard skog 71	Fax +47 69 24 10 40
Service		N-1599 Moss	http://www.sew-eurodrive.no sew@sew-eurodrive.no
Peru			
Assembly	Lima	SEW DEL PERU MOTORES REDUCTORES	Tel. +51 1 3495280
Sales		S.A.C.	Fax +51 1 3493002
Service		Los Calderos, 120-124 Urbanizacion Industrial Vulcano, ATE, Lima	http://www.sew-eurodrive.com.pe sewperu@sew-eurodrive.com.pe
Poland			
Assembly	Lodz	SEW-EURODRIVE Polska Sp.z.o.o.	Tel. +48 42 67710-90
Sales		ul. Techniczna 5	Fax +48 42 67710-99
Service		PL-92-518 Łódź	http://www.sew-eurodrive.pl sew@sew-eurodrive.pl
		24 Hour Service	Tel. +48 602 739 739 (+48 602 SEW SEW) sewis@sew-eurodrive.pl
Portugal			
Assembly	Coimbra	SEW-EURODRIVE, LDA.	Tel. +351 231 20 9670
Sales		Apartado 15	Fax +351 231 20 3685
Service		P-3050-901 Mealhada	http://www.sew-eurodrive.pt infosew@sew-eurodrive.pt
Romania			
Sales	București	Sialco Trading SRL	Tel. +40 21 230-1328
Service		str. Madrid nr.4 011785 Bucuresti	Fax +40 21 230-7170 sialco@sialco.ro
Russia			
Assembly	St. Petersburg	ZAO SEW-EURODRIVE	Tel. +7 812 3332522 +7 812 5357142
Sales		P.O. Box 36	Fax +7 812 3332523
Service		195220 St. Petersburg Russia	http://www.sew-eurodrive.ru sew@sew-eurodrive.ru
Senegal			
Sales	Dakar	SENEMECA	Tel. +221 338 494 770
		Mécanique Générale	Fax +221 338 494 771
		Km 8, Route de Rufisque	senemeca@sentoo.sn
		B.P. 3251, Dakar	
Serbia			
Sales	Beograd	DIPAR d.o.o.	Tel. +381 11 347 3244 / +381 11 288 0393
		Ustanicka 128a	Fax +381 11 347 1337
		PC Košum, IV floor	office@dipar.co.yu
		SCG-11000 Beograd	
Singapore			
Assembly	Singapore	SEW-EURODRIVE PTE. LTD.	Tel. +65 68621701
Sales		No 9, Tuas Drive 2	Fax +65 68612827
Service		Jurong Industrial Estate	http://www.sew-eurodrive.com.sg sewsingapore@sew-eurodrive.com
		Singapore 638644	



Slovakia			
Sales	Bratislava	SEW-Eurodrive SK s.r.o. Rybničná 40 SK-831 06 Bratislava	Tel. +421 2 33595 202 Fax +421 2 33595 200 sew@sew-eurodrive.sk http://www.sew-eurodrive.sk
	Žilina	SEW-Eurodrive SK s.r.o. Industry Park - PChZ ulica M.R.Štefánika 71 SK-010 01 Žilina	Tel. +421 41 700 2513 Fax +421 41 700 2514 sew@sew-eurodrive.sk
	Banská Bystrica	SEW-Eurodrive SK s.r.o. Rudlovska cesta 85 SK-974 11 Banská Bystrica	Tel. +421 48 414 6564 Fax +421 48 414 6566 sew@sew-eurodrive.sk
	Košice	SEW-Eurodrive SK s.r.o. Slovenská ulica 26 SK-040 01 Košice	Tel. +421 55 671 2245 Fax +421 55 671 2254 sew@sew-eurodrive.sk
Slovenia			
Sales Service	Celje	Pakman - Pogonska Tehnika d.o.o. Ul. XIV. divizije 14 SLO - 3000 Celje	Tel. +386 3 490 83-20 Fax +386 3 490 83-21 pakman@siol.net
South Africa			
Assembly Sales Service	Johannesburg	SEW-EURODRIVE (PROPRIETARY) LIMITED Eurodrive House Cnr. Adcock Ingram and Aerodrome Roads Aeroton Ext. 2 Johannesburg 2013 P.O.Box 90004 Bertsham 2013	Tel. +27 11 248-7000 Fax +27 11 494-3104 http://www.sew.co.za info@sew.co.za
	Cape Town	SEW-EURODRIVE (PROPRIETARY) LIMITED Rainbow Park Cnr. Racecourse & Omuramba Road Montague Gardens Cape Town P.O.Box 36556 Chempet 7442 Cape Town	Tel. +27 21 552-9820 Fax +27 21 552-9830 Telex 576 062 cfoster@sew.co.za
	Durban	SEW-EURODRIVE (PROPRIETARY) LIMITED 2 Monaceo Place Pinetown Durban P.O. Box 10433, Ashwood 3605	Tel. +27 31 700-3451 Fax +27 31 700-3847 hengela@sew.co.za
Spain			
Assembly Sales Service	Bilbao	SEW-EURODRIVE ESPAÑA, S.L. Parque Tecnológico, Edificio, 302 E-48170 Zamudio (Vizcaya)	Tel. +34 94 43184-70 Fax +34 94 43184-71 http://www.sew-eurodrive.es sew.spain@sew-eurodrive.es
Sweden			
Assembly Sales Service	Jönköping	SEW-EURODRIVE AB Gnejsvägen 6-8 S-55303 Jönköping Box 3100 S-55003 Jönköping	Tel. +46 36 3442 00 Fax +46 36 3442 80 http://www.sew-eurodrive.se info@sew-eurodrive.se



Switzerland			
Assembly	Basel	Alfred Imhof A.G.	Tel. +41 61 417 1717
Sales		Jurastrasse 10	Fax +41 61 417 1700
Service		CH-4142 Münchenstein bei Basel	http://www.imhof-sew.ch info@imhof-sew.ch
Thailand			
Assembly	Chonburi	SEW-EURODRIVE (Thailand) Ltd.	Tel. +66 38 454281
Sales		700/456, Moo.7, Donhuaroh	Fax +66 38 454288
Service		Muang Chonburi 20000	sewthailand@sew-eurodrive.com
Tunisia			
Sales	Tunis	T. M.S. Technic Marketing Service Zone Industrielle Mghira 2 Lot No. 39 2082 Fouchana	Tel. +216 71 4340-64 + 71 4320-29 Fax +216 71 4329-76 tms@tms.com.tn
Turkey			
Assembly	Istanbul	SEW-EURODRIVE	Tel. +90 216 4419164, 3838014, 3738015
Sales		Hareket Sistemleri San. ve Tic. Ltd. Sti.	Fax +90 216 3055867
Service		Bagdat Cad. Koruma Cikmazi No. 3 TR-34846 Maltepe ISTANBUL	http://www.sew-eurodrive.com.tr sew@sew-eurodrive.com.tr
Ukraine			
Sales	Dnepropetrovsk	SEW-EURODRIVE	Tel. +380 56 370 3211
Service		Str. Rabochaja 23-B, Office 409 49008 Dnepropetrovsk	Fax +380 56 372 2078 http://www.sew-eurodrive.ua sew@sew-eurodrive.ua
USA			
Production	Southeast Region	SEW-EURODRIVE INC.	Tel. +1 864 439-7537
Assembly		1295 Old Spartanburg Highway	Fax Sales +1 864 439-7830
Sales		P.O. Box 518	Fax Manufacturing +1 864 439-9948
Service		Lyman, S.C. 29365	Fax Assembly +1 864 439-0566
Cooperate Offices			Fax Confidential/HR +1 864 949-5557 http://www.seweurodrive.com cslyman@seweurodrive.com
Assembly	Northeast Region	SEW-EURODRIVE INC.	Tel. +1 856 467-2277
Sales		Pureland Ind. Complex	Fax +1 856 845-3179
Service		2107 High Hill Road, P.O. Box 481 Bridgeport, New Jersey 08014	csbridgeport@seweurodrive.com
	Midwest Region	SEW-EURODRIVE INC.	Tel. +1 937 335-0036
		2001 West Main Street	Fax +1 937 440-3799
		Troy, Ohio 45373	cstroy@seweurodrive.com
	Southwest Region	SEW-EURODRIVE INC.	Tel. +1 214 330-4824
		3950 Platinum Way	Fax +1 214 330-4724
		Dallas, Texas 75237	csdallas@seweurodrive.com
	Western Region	SEW-EURODRIVE INC.	Tel. +1 510 487-3560
		30599 San Antonio St.	Fax +1 510 487-6433
		Hayward, CA 94544	cshayward@seweurodrive.com
Additional addresses for service in the USA provided on request!			
Venezuela			
Assembly	Valencia	SEW-EURODRIVE Venezuela S.A.	Tel. +58 241 832-9804
Sales		Av. Norte Sur No. 3, Galpon 84-319	Fax +58 241 838-6275
Service		Zona Industrial Municipal Norte Valencia, Estado Carabobo	http://www.sew-eurodrive.com.ve ventas@sew-eurodrive.com.ve sewfinanzas@cantv.net



Index

A

Accessory equipment.....	84
Alternative plug connector	
CFM brakemotor cable	38
CFM motor cable	34
DFS brakemotor cable	30
DFS motor cable	28
RH.M / RH.L resolver cable	44
Alternative plug connector for extension cable for CFM motors	36
Alternative plug connector for extension cable for DFS motors	29
Assembly	
Connector	21
Assembly – SM5./SM6. and SB5./SB6 power connectors	114
Assembly of signal plug connectors (resolver/HIPERFACE®).....	115
Assembly, safety notes	9

B

BME brake rectifier.....	69, 75
BMH brake rectifier	71, 77
BMK brake rectifier.....	72, 78
BMP brake rectifier.....	70, 76
BMV brake control system	78
BR brake (CFM)	
Measuring the working air gap	95
Operating currents BR brake	107
Retrofitting the manual brake release CFM112	98
Retrofitting the manual brake release CFM71 and CFM90	96
Brake	
Connection via plug connector.....	69
Connection via terminal box.....	80
Brake coil resistance	106
Brake malfunctions	92
Brakemotor cable	
CFM motors	37
Brakemotor cable for CFM motors	
Alternative plug connector	38
Pin assignment	38
Types	37
Brakemotor cable for DFS motors	
Pin assignment	30
Types	30
Brakemotor cables	

DFS motors.....	30
Brakemotor cables for DFS motors	
Alternative plug connector	30
Brakemotor extension cable for CFM motors	39
Alternative plug connector	40
Pin assignment	40
Types	39
Brakemotor extension cable for DFS motors.....	31
Alternative plug connector	31
Pin assignment	31
Types	31
Braking torques.....	106
BSG brake control unit.....	71
BSG control unit.....	79

C

Cable	
Assembly of SB5./SB6. power connectors	114
Assembly of signal plug connectors (resolver/HIPERFACE®)	115
SM11/SB11 power connector assembly.....	111
Wiring diagrams.....	118
Cable cross section dimensioning	23
Cable dimensioning according to EN 60402.....	23
Cable load.....	24
Cables	
Brakemotor cable for CFM motors.....	37
Brakemotor cables for DFS motors	30
Brakemotor extension cable for CFM motors	39
Brakemotor extension cable for DFS motors	31
CFM motor cable	33
CFM motor cable – extension cable	35
DFS motor cable.....	28
DFS motor cable – extension cable.....	29
Feedback cable for HIPERFACE® encoders	47
Feedback cable for resolver	41
Power cables for CFM motors	32
Power cables for DFS motors.....	27
RH.M/RH.L resolver cable – DFS/CFM terminal box for MOVIAXIS® MX	46
RH.M/RH.L resolver cable – DFS/C	
M terminal box for MOVIDRIVE® MDX61B with DC 5 V supply.....	45
RH.M/RH.L resolver cable for MOVIAXIS® MX	
RH.M/RH.L resolver cable for MOVIDRIVE® MDX61B	42
RH.M/RH.L resolver extension cable.....	44



Structure of the brakemotor cables for CFM motors	32
Structure of the brakemotor cables for DFS motors	27
Structure of the feed back cable for resolver	41
Structure of the motor cables for CFM motors	32
Structure of the motor cables for DFS motors	27
VR forced cooling fan	56
CFM brakemotor extension cable – alternative plug connector	40
CFM motors	
Alternative plug connector for brakemotor cable	38
Alternative plug connector for motor extension cable	36
Brakemotor cable	37
Brakemotor cable pin assignment	38
Brakemotor cable types	37
Brakemotor extension cable	39
Brakemotor extension cable – alternative plug connector	40
Brakemotor extension cable – pin assignment	40
Brakemotor extension cable types	39
Extension cable	35
Motor cable	33
Motor cable – alternative plug connector	34
Motor cable pin assignment	33
Motor cable types	33
Motor extension cable	35
Motor extension cable pin assignment	35
Motor structure	12
Power cables	32
Structure of the brakemotor cables	32
Structure of the motor cables	32
Unit designation	15
Connecting the encoder system using SM../SB.. plug connectors	22
Connecting the motor using SM../SB.. plug connectors	22
Connecting the motor via the terminal box	64
Connection with terminal box	105
Connector	
Assembly	21
D	
Designated use	8
DFS brakemotor extension cable – alternative plug connector	31
DFS motors	
Alternative plug connector for motor extension cable	29
Brakemotor cable – alternative plug connector	30
Brakemotor cable – pin assignment	30
Brakemotor cable types	30
Brakemotor cables	30
Brakemotor extension cable	31
Brakemotor extension cable – alternative plug connector	31
Brakemotor extension cable – pin assignment	31
Brakemotor extension cable types	31
Extension cable	29
Extension cable – pin assignment	29
Motor cable	28
Motor cable – alternative plug connector	28
Motor cable pin assignment	28
Motor cable types	28
Motor extension cable	29
Motor structure	11
Power cables	27
Structure of the brakemotor cables	27
Structure of the motor cables	27
Unit designation	14
Dimensioning the cable cross section	23
Disposal	10
Drying the motor	18
E	
Electrical installation	21
Safety notes	10
Encoder cable (HIPERFACE®) for MOVIDRIVE® MDX61B and MOVIAXIS® MX	48
Exclusion of liability	6
Extended storage	17
Extension cable for CFM motor cable	
Types	35
Extension cable for DFS motor cable	
Pin assignment	29
Types	29
Extension cable for resolver	
RH.M/RH.L	44
F	
Feedback cable for HIPERFACE® encoders	47
Feedback cable for resolver	41
Structure	41
G	
General notes	5



H			
HIPERFACE® Encoder cable for MOVIDRIVE® MDX61B and MOVIAXIS® MX	48		
I			
Inspection	93		
Inspection intervals	94		
Inspection work for the B brake (DFS)	94		
Inspection work for the BR brake (CFM)	95		
Inspection/maintenance			
Safety notes	10		
Installation			
Electrical	21		
Mechanical	17		
Tools/resources	17		
Installation/assembly	9		
Installing the motor	19		
Insulation resistance too low	18		
K			
KTY temperature sensor	84		
M			
Main technical data of the servomotors	100		
DFS/CFM motors	101		
Key	100		
Maintenance	93		
Cleaning	94		
Connection cables	94		
Safety notes	10		
Malfunctions	91		
Motor	91		
Malfunctions when operated with a servo inverter	91		
Measuring the working air gap (BR brake for CFM motors)	95		
Mechanical installation	17		
Before you begin	17		
Preliminary work	17		
Tolerances	20		
Motor			
Installation	19		
Motor cable for CFM motors			
Pin assignment	33		
Motor cable for DFS motors			
Pin assignment	28		
Motor cables for CFM motors	33		
Alternative plug connector	34		
Structure	32		
Types	33		
Motor cables for DFS motors	28		
Alternative plug connector	28		
Structure	27		
Types	28		
Motor extension cable for CFM motors	35		
Alternative plug connector	36		
Pin assignment	35		
Motor extension cable for DFS motors			
Alternative plug connector	29		
Motor extension cables for DFS motors	29		
Motor malfunctions	91		
Motor protection, thermal	21		
Motor structure	11		
CFM synchronous servomotor	12		
DFS synchronous servomotor	11		
Mounting tolerances	20		
MOVIAXIS® MX			
HIPERFACE® encoder cable	48		
RH.M/RH.L resolver cable – DFS/CFM terminal box	46		
MOVIDRIVE® MDX61B			
HIPERFACE® encoder cable	48		
RH.M/RH.L resolver cable – DFS/CFM terminal box with DC 5 V supply	45		
N			
Nameplate	13		
Notes			
General	5		
Safety	5, 7		
Wiring	21		
O			
Operation			
Safety notes	10		
P			
Pin assignment			
Brakemotor cable for CFM motors	38		
Brakemotor cable for DFS motors	30		
Brakemotor extension cable for CFM motors	40		
Brakemotor extension cable for DFS motors	31		
Extension cable for DFS motor cable	29		
Motor cable for CFM motors	33		
Motor cable for DFS motors	28		
Motor extension cable for CFM motors	35		
Plug connectors			



Technical data.....	105	T	
Power cables		Target group	8
CFM motors	32	Technical data	100
DFS motors.....	27	Brake coil resistance.....	106
		Braking torques.....	106
R		Connection with terminal box.....	105
Resistance		Operating currents BR brake	107
Brake coil	106	Plug connectors	105
Resources for installation.....	17	Work done	106
Retrofitting the manual brake release (BR brake for CFM112).....	98	Temperature sensor	
Retrofitting the manual brake release (BR brake for CFM71/90).....	96	KTY.....	84
RH.M / RH.L resolver cable		TF temperature sensor	84
Plug connector	44	Thermal motor protection.....	21
RH.M/RH.L resolver cable – DFS/CFM terminal box for MOVIAXIS® MX.....	46	Tools for installation	17
RH.M/RH.L resolver cable – DFS/CFM terminal box for MOVIDRIVE® MDX61B with DC 5 V supply	45	Transportation.....	9
RH.M/RH.L resolver cable for MOVIAXIS® MX.....	43		
RH.M/RH.L resolver cable for MOVIDRIVE® MDX61B	42	U	
RH.M/RH.L resolver extension cable	44	Unit designation	
Rights to claim under limited warranty	6	CFM	15
		DFS.....	14
		Use, designated	8
S			
Safety notes	7	V	
Designated use	8	VR forced cooling fan	85
Disposal	10		
Electrical installation	10	W	
Inspection/maintenance	10	Wiring diagrams	118
Installation/assembly.....	9	CFM motors with power connector	119
Startup/operation	10	CFM motors with signal connector	119
Structure	5	CFM motors with terminal box	121
Transportation/storage.....	9	DFS motors with power connector.....	123
Scope of delivery	15	DFS motors with signal connector	123
Serial number, example	16	DFS motors with terminal box.....	125
SM11/SB11 power connector (DFS motors).....	111	VR forced cooling fan	127
SM../SB.. plug connectors		Wiring notes.....	21
Connecting the motor and the encoder system ..	22	Work done	106
Startup	90		
Prerequisites	90		
Startup, safety notes	10		
Storage	9, 17		
Structure of the feed back cable for resolver	41		
Switched-mode power supply			
UWU52A	89		

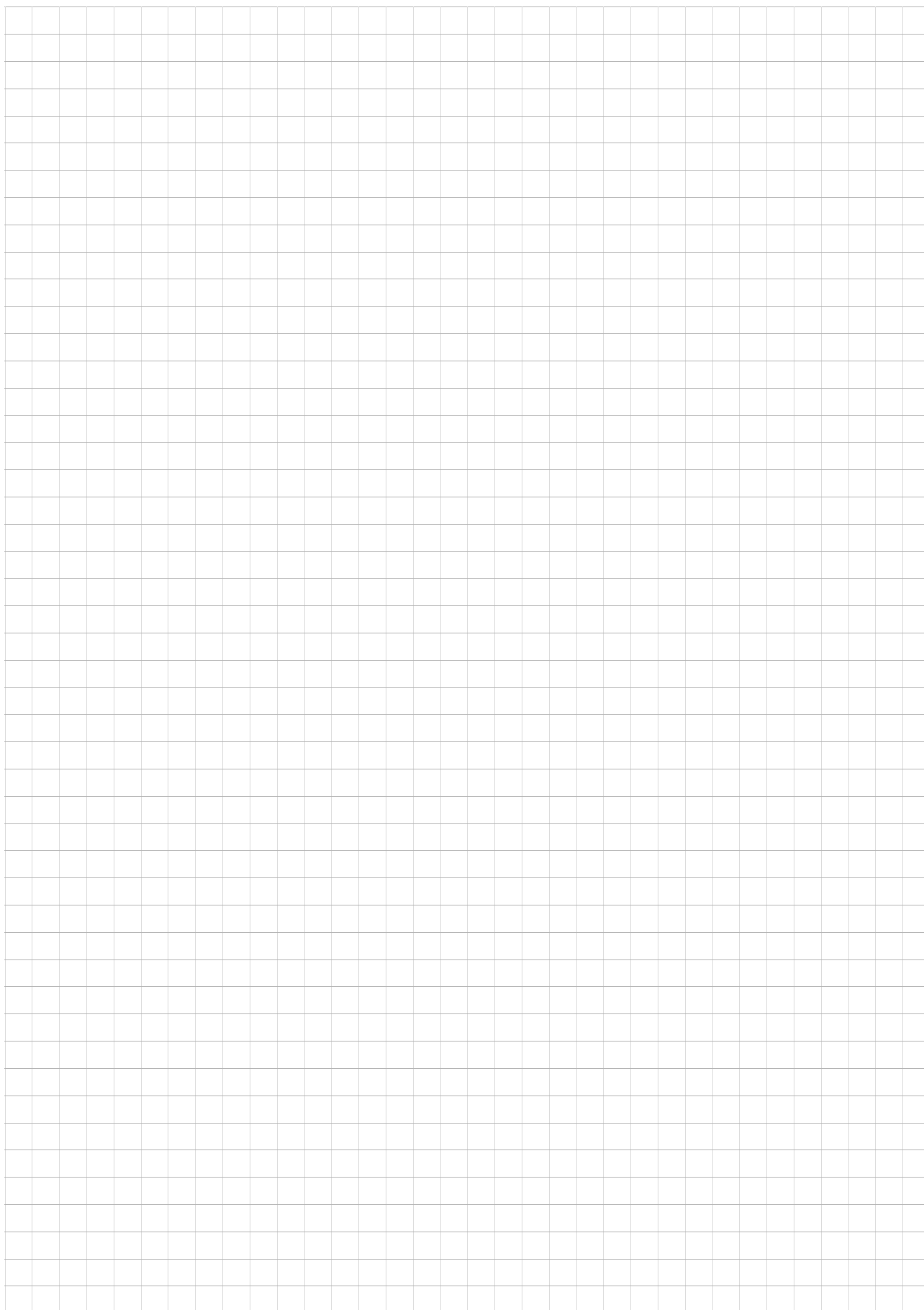

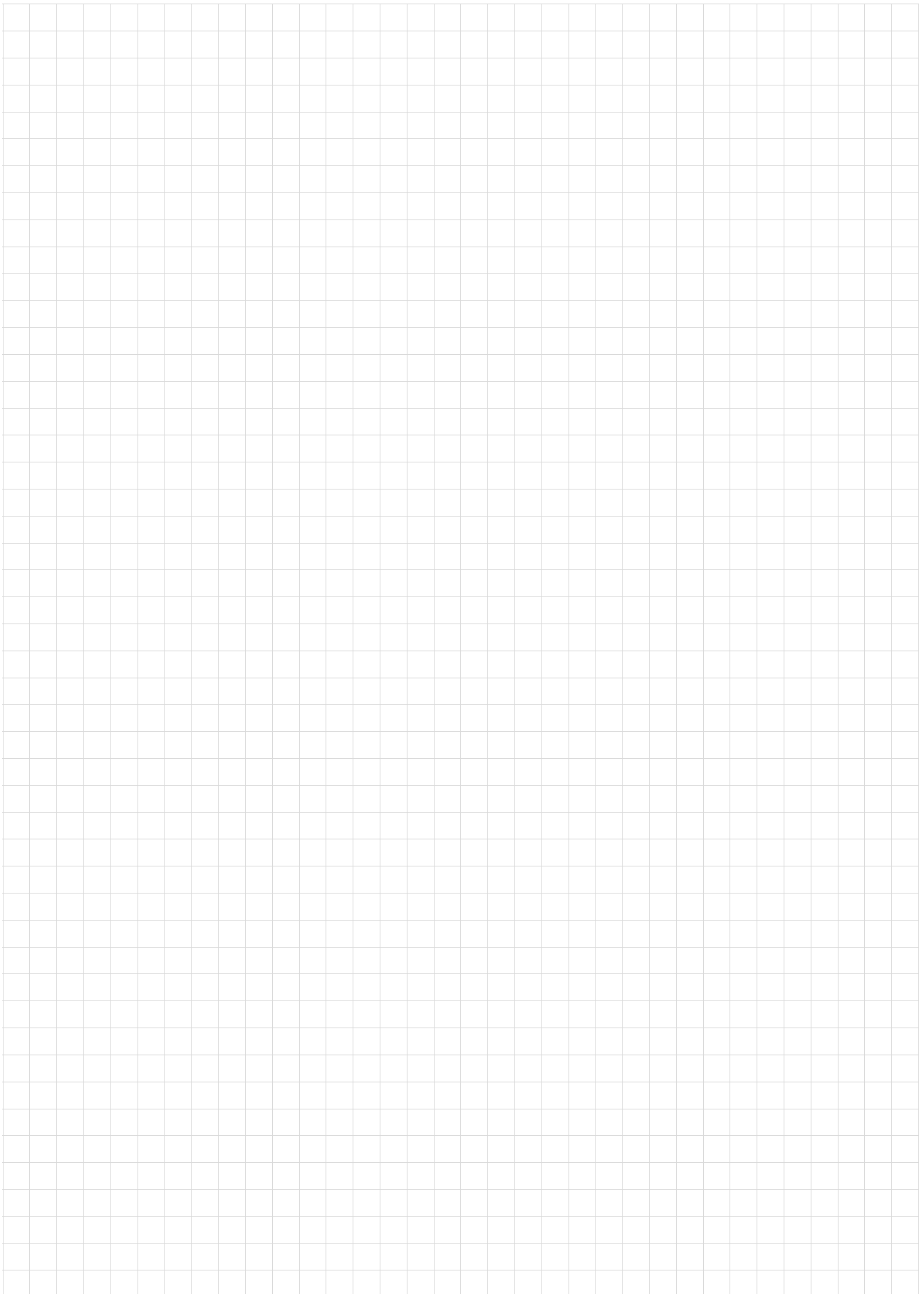

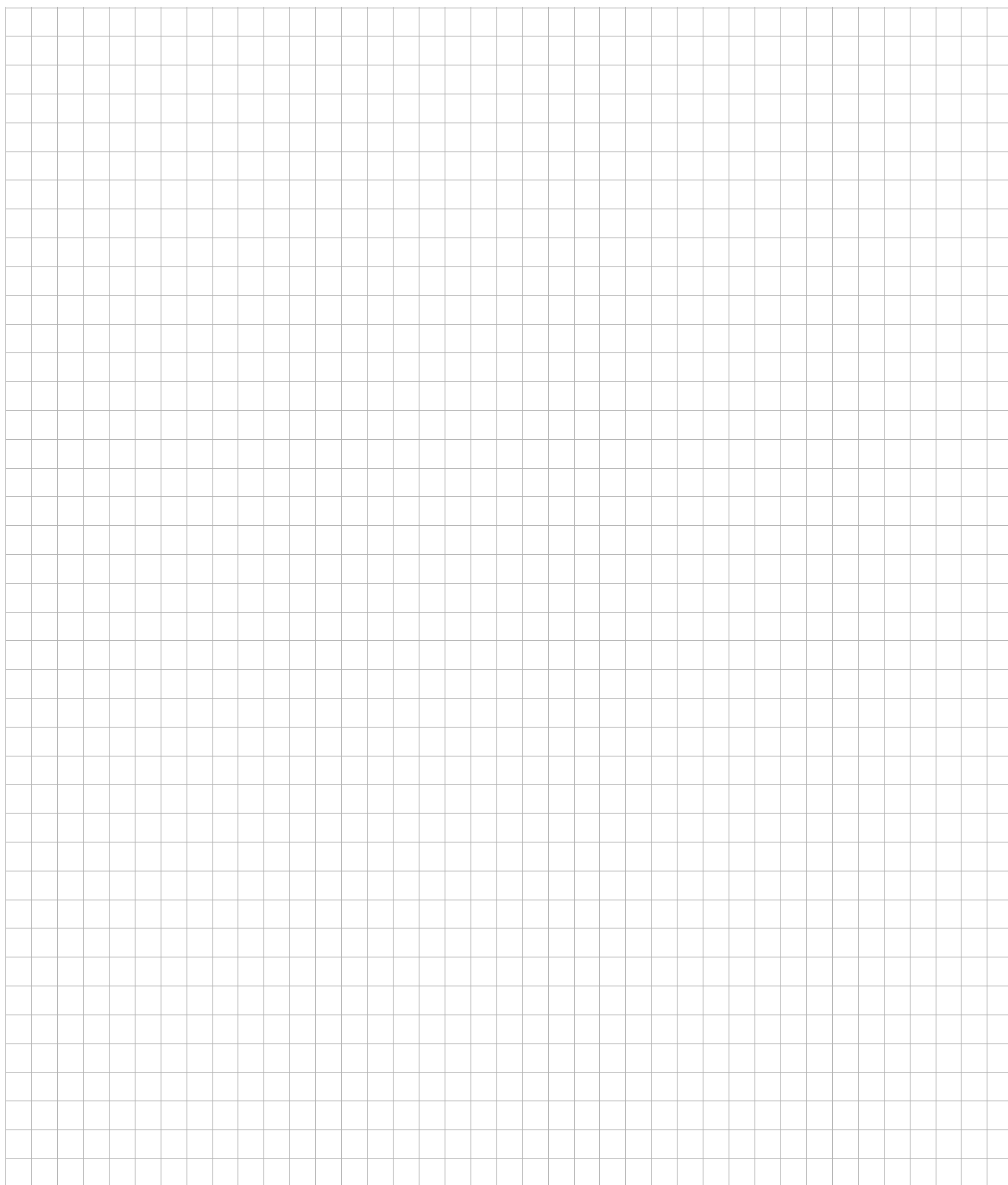

How we're driving the world

With people who think fast and develop the future with you.

With a worldwide service network that is always close at hand.

With drives and controls that automatically improve your productivity.

With comprehensive knowledge in virtually every branch of industry today.

With uncompromising quality that reduces the cost and complexity of daily operations.



SEW-EURODRIVE
Driving the world

With a global presence that offers responsive and reliable solutions. Anywhere.

With innovative technology that solves tomorrow's problems today.

With online information and software updates, via the Internet, available around the clock.

SEW
EURODRIVE

SEW-EURODRIVE GmbH & Co KG
P.O. Box 3023 · D-76642 Bruchsal / Germany
Phone +49 7251 75-0 · Fax +49 7251 75-1970
sew@sew-eurodrive.com

→ www.sew-eurodrive.com