

PRODEMAND

YMMS: 2012 Chevrolet Cruze LS
 Engine: 1.8L Eng
 VIN:

Feb 16, 2021
 License:
 Odometer:

REPAIR INSTRUCTIONS > WINDSHIELD WIPER ARM REPLACEMENT

Fig 1: Windshield Wiper Arm Components

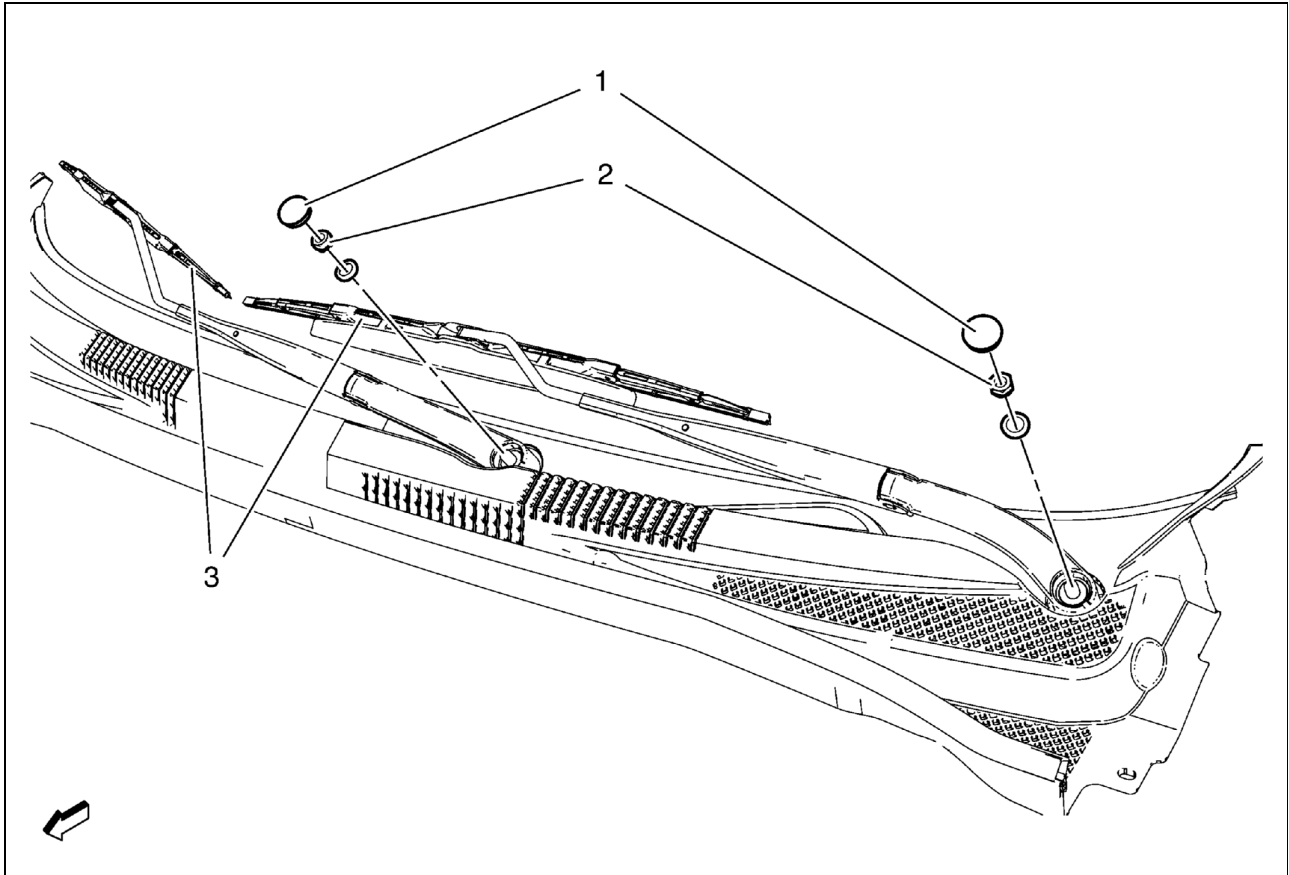

Courtesy of GENERAL MOTORS COMPANY

Windshield Wiper Arm Replacement

| Callout | Component Name |
|---------|--|
| 1 | Windshield Wiper Arm Finish Cap Procedure Use a small flat-bladed tool to remove finish cap. |
| 2 | Windshield Wiper Arm Nut <div style="border: 1px solid black; padding: 10px; margin-top: 10px; text-align: center;"> CAUTION: Refer to Fastener Caution . </div> |

| | |
|---|---|
| | <p>Procedure</p> <ol style="list-style-type: none"> 1. Locate the transparent circle with a black dot in the center at the lower windshield blackout area. 2. Position the wiper arm to the pivot shaft so that the wiper blade is centered across the transparent circle. 3. Lift the arm blade portion while pushing down the arm onto the pivot shaft. 4. Install the wiper arm nut. 5. Hold the wiper arm stationary in position as previously stated. 6. Torque the wiper arm nut. 7. Release the wiper arm assembly. 8. Repeat the same procedure for the other wiper arm. <p>Tighten 24.5 N.m (18 lb ft)</p> |
| 3 | <p>Windshield Wiper Arm Assembly</p> <p>Procedure</p> <p>Grasp the end of the wiper arm at the wiper transmission pivot shaft and rock the arm side to side in order to release the windshield wiper arm from the wiper transmission pivot shaft.</p> |