

HEAVY-HAUL OPERATOR'S GUIDE

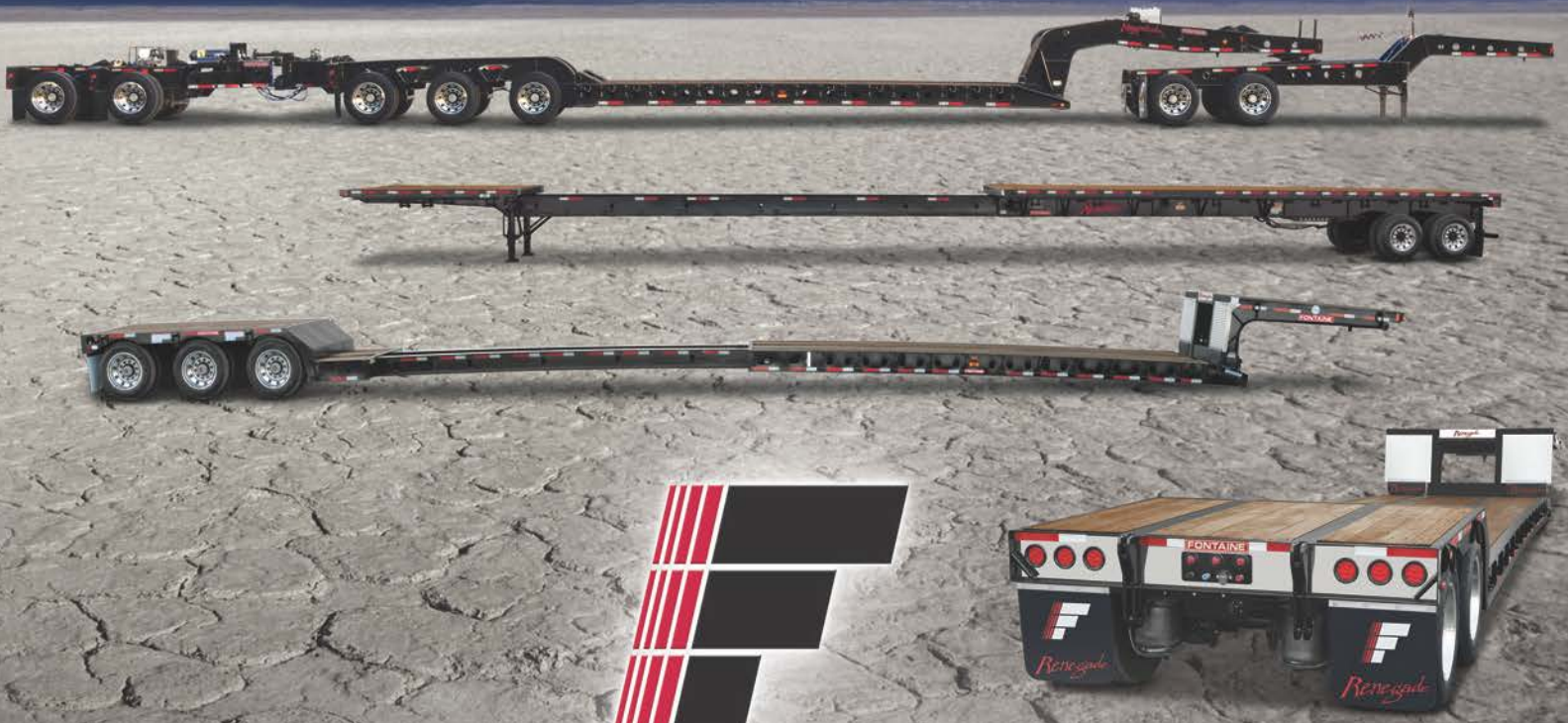

FONTAINE[®]
HEAVY-HAUL



Table of Contents

Section 1: Operating Instructions	1-1
Operator Instructions	1-1
Operating Limits and Restrictions	1-3
Decal Locations.....	1-4
Front Decals	1-4
Side Decals	1-5
Gooseneck Decals	1-10
Blue Wire Auxiliary Equipment Decals	1-11
ABS Decals.....	1-12
Landing Gear	1-13
Travel Directions	1-13
Suspension System.....	1-15
Axle Alignment.....	1-15
Single-Axle Trailers.....	1-15
Tandem-Axle Trailers.....	1-15
How to Correct the Alignment of Axles.....	1-16
Checking Trailer Ride Height (Xcalibur Trailers).....	1-17
Preparation	1-17
Designed Kingpin Height Measurement.....	1-17
Designed Ride Height Measurement.....	1-18
Height Control Valve Adjustment	1-19
Suspension Ride Height Adjustment.....	1-20
Anti-Lock Braking System	1-22
Electronic Control Unit (ECU) Malfunction.....	1-22
ABS Indicator Lamp.....	1-22
Coupling and Uncoupling	1-24
Coupling and Uncoupling Procedures	1-24
Uncoupling Tractor-Semitrailers.....	1-28
Accessing Deck (Xcalibur Units Only)	1-30
Anchor Points	1-31
Working Load Limits	1-31
Special Anchor Points	1-32
Working Load Limits	1-32

Lashing Rings.....	1-32
Sliding Winch Xcalibur Trailers	1-32
Renegade and Magnitude Trailers.....	1-33
Outrigger Loads	1-34
Bulkhead Securement (Xcalibur Trailers).....	1-35
Section 2: Optional Features and Operating Instructions	2-1
Optional Features.....	2-1
Deck Inserts	2-1
Decks Modular	2-1
Flip Axle.....	2-2
Flip Box.....	2-2
Jeep 302.....	2-3
Jeep 402.....	2-3
Jeep 453.....	2-4
Mod Connection	2-4
EQ2 Spreader	2-5
Fixed Spreader	2-5
EQ1 Spreader	2-6
Nomenclature.....	2-7
Magnitude Modular Trailer	2-7
Non-Ground-Bearing Operating Procedures.....	2-10
Telescoping Deck Operating Procedures.....	2-11
Manual Height Control for Trailers with Air Ride Suspensions	2-11
Locking Pins.....	2-12
Locking Pins Procedure.....	2-12
Sliding Suspension (Xcalibur Trailers).....	2-12
EQ1 – Hydraulic Equalizer Spreader	2-14
EQ1 and EQ2 – Nitrogen Equalizer Systems.....	2-23
Raise Feature	2-24
Backing Up Cautions	2-24
EQ2 – Hydraulic Equalizer System	2-25
EQ2 – Hydraulic Equalizer Spreader Operating Instructions.....	2-26
With Trailer Loaded	2-31
Unloading Trailer	2-31
EQ2 – Hydraulic Equalizer System Pressure Dump Switch.....	2-32

EQ2 – Hydraulic Equalizer System Maintenance.....	2-33
Nitrogen Pressure and Charging.....	2-34
Power Unit (13HP) Installation	2-38
Non Ground-Bearing Gooseneck – Frame Jack Operation.....	2-39
Mechanical – Removable Gooseneck Operation	2-40
Load Characteristics – Double Drop Extendables.....	2-41
Deck Extensions Operations	2-42
Shim Points and Applications	2-43
Rigid Spreader Versus Hydraulic Spreader	2-44
Front Gooseneck Electrical/Glad Hands Hookups.....	2-45
Rear of Trailer Electrical/Air Coupler Hook Ups	2-46
Suspension Ride Height Adjustment	2-47
IGUS – Installation	2-50
Roller and Shaft – Installation.....	2-52
Hydraulic Requirement.....	2-56
Section 3: Maintenance Schedule	3-1
Maintenance Schedule.....	3-1
Daily Intervals	3-1
Monthly Intervals.....	3-1
Six Month Interval	3-2
Lubrication Notes.....	3-3
Lubrication Intervals	3-3
Leaf Type Springs Care and Maintenance	3-4
Service Tips	3-4
Basic Trailer Maintenance	3-6
Kingpin and Fifth Wheel Area	3-6
Rear Impact Guards	3-6
Wheel and Rim Care	3-6
How to Service and Install Wheel Bearings.....	3-7
Inspect for Damage.....	3-7
Adjustment of Bearings	3-8
Hub Installation and Maintenance.....	3-9
Disc Wheel Mounting—6 and 10 Stud Hubs BALL SEAT Mounted Disc Wheels.....	3-9
Disc Wheel Mounting—8 and 10 Stud Hubs HUB PILOTED Disc Wheels.....	3-10
Self-Adjusting Slack Adjuster.....	3-11

Operational Check	3-11
Maintenance	3-11
Lubrication	3-11
Inspection	3-12
Maintenance Schedule	3-13
Tips for Prolonged Brake Drum Life	3-13
Tire Maintenance	3-14
Inflation Pressure	3-14
Tire Inspection	3-14
Drive Carefully	3-15
Do Not Overload	3-15
Drive at Proper Speeds	3-15
Balancing	3-16
Rotation	3-16
Storage	3-16
Recommendations for the Use of Dynamometers	3-16
Demounting and Mounting of Tube Type Tires	3-17
Tube Type Tires	3-17
Primary Inflation	3-17
Final Inflation	3-17
Demounting	3-17
Demounting and Mounting of Tubeless Tires	3-18
Mounting	3-18
Tubeless Inflation	3-18
Additional Information	3-18
Tire Mixing	3-18
Electrical System	3-19
Lights and Wiring	3-19
Turn Signal and Hazard Flasher System	3-19
Reflectors	3-19
Stop, Tail, Turn, Marker, and Identification Lights	3-20
License Lamp	3-20
Hydraulic Oil	3-21
Draining Oil Reservoir	3-21
Oil Recommendations	3-21

Care of Wood Decking for Platform Trailers 3-22

Hydraulic Equalizer Spreader 3-23

 Maintenance 3-23

Hydraulic System Troubleshooting 3-24

 Slow or No Hydraulic Lift Ability Under Load 3-24

Troubleshooting—Analyzing and Diagnosing Trailer Service 3-26

 Brakes 3-26

 Wheels, Tires, and Alignment 3-28

 Landing Gear 3-30

 Electrical System 3-31

 Hydraulic System 3-32

Maintenance Records 3-34

Section 4: Fontaine Parts and Service 4-1

 Parts and Service 4-1

Index 1

Table of Figures

Figure 1-1. Wheel Chock.....	1-17
Figure 1-2. ID tag on HT suspension	1-18
Figure 1-3. ID tag on Intraax	1-18
Figure 1-4. Measure ride height	1-18
Figure 1-5. Realign lever arm	1-19
Figure 1-6. "Lashing Ring"	1-32
Figure 1-7. "Lashing Ring"	1-32
Figure 1-8. "Sliding Winch"	1-32
Figure 1-9. Typical Bolt-On Fontaine Bulkhead	1-35
Figure 2-1. Hydraulic Control Valve	2-10
Figure 2-2. Rotate Height Adjustment Handle "D"	2-10
Figure 2-3. Single-Spool Main Cylinder Operation Valve.....	2-20
Figure 2-4. Accumulator Safety Valve In "Off" Position	2-26
Figure 2-5. Air Suspension On/Off Valve	2-28
Figure 2-6. Ride Height Adjustment Arm.....	2-29
Figure 2-7. Bottom Air-Lock Pin Valve	2-29
Figure 2-8. Drop Leg Landing Gear Adjustment Handle	2-30
Figure 2-9. EQ2 Mainshaft	2-39

Lowbed, Extendable and Specialty Trailer Limited Warranty

Fontaine Trailer Company ("Fontaine") warrants to the first user only ("First User") that each new lowbed, extendable and specialty trailer ("Trailer") manufactured by Fontaine will be free from defects in materials and workmanship for twelve (12) months from the delivery of the Trailer to First User. In addition, Fontaine warrants to First User that the main structural members and supports of the Trailer will be free from defects in material and workmanship for twenty-four (24) months from the date of delivery of Trailer to First User.

This Limited Warranty does not apply to and does not cover defects in material and workmanship due to or in any way arising out of:

- Failure to properly maintain the Trailer or any other improper maintenance of the Trailer;
- Abnormal use and service, including (without limitation) loading, unloading and/or transportation of non-uniformly distributed loads, use with corrosive cargo, and/or failure to adequately restrain or secure loads such that the Trailer is subjected to strains or impacts greater than are imposed by normal use;
- Total weight of Trailer and cargo exceeding the Gross Vehicle Weight Rating (GVWR) stated on the vehicle identification plate affixed to the Trailer by Fontaine or the loading of each axle exceeding the Gross Axle Weight Rating (GAWR) listed on the vehicle identification plate;
- Accidents;
- Any other misuse or negligence.

In addition, this Limited Warranty does not cover:

- Tires;
- Except with respect to title, used goods sold by Fontaine, all of which are sold "as is";
- Except with respect to title, items or parts not manufactured by Fontaine; provided, that Fontaine will, as an accommodation to First User, pass on to First User any warranty it receives from the manufacturer of such items or parts, but only to the extent allowed by such manufacturer;
- Trailers that have been repaired or altered by anyone other than an authorized repair facility approved by Fontaine, unless in Fontaine's sole and exclusive judgment, such repairs are in no way responsible for the condition complained of; and
- Parts that are not defective but that wear out under normal use, such as (but not limited to) light bulbs, electrical receptacles, paint and coatings, brakes, linings, drums and return springs, equalizers, torque rod and camshaft bushings, camshafts, slack adjusters, brake cylinder diaphragms, springs, slider pads, wheel bearings, oil and oil seals, rim clamps and studs, gaskets and sealers, and all types of floors and floorboards.

If First User notifies Fontaine in writing within the applicable warranty period of a defect in the Trailer and Fontaine determines, after such tests and/or inspections as Fontaine deems appropriate, that such Trailer or part is not in conformity with this Limited Warranty, Fontaine will repair or replace, at its sole

option, such defective Trailer or part, provided First User returns such Trailer or part to such repair facility as may be designated by Fontaine, freight prepaid. No Trailer or part shall be returned without Fontaine's prior approval. This shall be First User's exclusive remedy for Fontaine's liability hereunder. Any claims not made within the applicable warranty period are deemed waived by First User. In lieu of repairing or replacing the defective Trailer or part, Fontaine may, at its sole option, refund the purchase price of such Trailer or part.

THIS IS FONTAINE'S ONLY WARRANTY. FONTAINE MAKES NO OTHER WARRANTY OF ANY KIND WHATSOEVER, EXPRESS OR IMPLIED. ALL IMPLIED WARRANTIES OF MERCHANTABILITY AND/OR FITNESS FOR A PARTICULAR PURPOSE ARE HEREBY DISCLAIMED BY FONTAINE AND EXCLUDED.

Fontaine's liability to First User, or anyone claiming through or on behalf of First User, with respect to any claim or loss arising out of the Trailer or alleged to have resulted from an act or omission of Fontaine, whether negligent or otherwise, and whether in tort, contract, or otherwise, including failure to deliver, delay in delivery, or breach of warranty, shall be limited to an amount equal to the purchase price of the Trailer or part with respect to which such liability is claimed or, where appropriate and at the option of Fontaine, to repair or replacement of the Trailer or part. In no event shall Fontaine be liable for any bodily injury, death, or property damage resulting from or in any way arising out of the Trailer or its sale, use, or manufacture or for any cargo loss or loss of use. Fontaine is not responsible for any financial loss due to lack of use of the Trailer or any expenses arising therefrom, including but not limited to lodging, fuel, towing, loss of revenue and other expenses or damages. **IN NO EVENT SHALL FONTAINE BE LIABLE FOR INCIDENTAL OR CONSEQUENTIAL DAMAGES, LOSSES, OR EXPENSES.**

This Limited Warranty may not be changed except in writing by an authorized officer of Fontaine.

THE PROVISIONS OF THIS LIMITED WARRANTY SHALL BE INTERPRETED AND GOVERNED UNDER THE LAWS OF THE STATE OF ALABAMA. This Limited Warranty gives you specific rights, and you may also have other rights that vary from state to state.

To facilitate coverage under this Limited Warranty, register the Trailer in Fontaine's warranty system at <http://fontainetrailer.com/warranty/>. For more information on Fontaine products, please visit www.fontainetrailer.com.

Section 1: Operating Instructions

Operator Instructions

Congratulations!

You have just purchased the finest trailer on the road today.

This manual has been prepared to assist you in the safe operation and maintenance of your FONTAINE Heavy Haul trailer. It contains important information on the proper use of your FONTAINE Heavy Haul trailer and the major components and optional equipment that is included.



DANGER

This box indicates when serious injury or death may occur if instructions are ignored.



WARNING

All operator instructions are provided for assistance in the proper operation of your trailer. Specific component operating instructions and your company's procedures should be consulted. These may include DOT and employer training programs or instructions.

This manual includes safety checks the trailer operator should perform.



CAUTION

This symbol indicates a procedure you must follow exactly or damage to components or equipment may occur. Serious personal injury may also result from failure to follow this procedure.

NOTE

This symbol is used throughout this manual to call attention to operations, procedures and instructions that are important for proper service. It may also indicate information that can make service quicker or easier.

Operator Instructions

All operator instructions are provided to assist in the proper operation of your trailer. Specific component operating instructions and your company's procedures should be consulted. These may include Department of Transportation (DOT) and employer training programs or instructions.

This manual includes safety checks the trailer operator should perform.



CAUTION

It is important that every trailer owner and/or operator have an organized Trailer Preventive Maintenance (TPM) program. The United States Department of Transportation requires by law that maintenance records be kept on every commercial highway vehicle. It is to your advantage to be able to show that regularly scheduled TPM inspection checks have been made on every piece of equipment operated.

A regular TPM program will not only ensure that you will get the most usage from your trailer, but will also assist in demonstrating that the equipment has been properly maintained.

You can get help in setting up and operating a trailer preventive maintenance program by sending for a **"Maintenance Manual for Trailers and Containers."** Write to the Truck Trailer Manufacturers Association, 1020 Princess Street, Alexandria, Virginia 22314.

IMPORTANT

Read this manual carefully. Should you have any questions, contact a FONTAINE factory representative immediately.

205-467-6171

This manual should be kept with the trailer at all times and should be left with the trailer when and if it is sold.

<http://www.fontaineheavyhaul.com>

Operating Limits and Restrictions

This FONTAINE trailer was designed for operation within legal highway speed limits on reasonable road surfaces for the type of service it was built to perform in accordance with the following:

1. This trailer was built to carry cargo within the limitations of two weight ratings on the identification plate. These ratings, GAWR and GVWR, are:
 - The GAWR (gross axle weight rating) is the structural capability of the lowest rated member of the running gear components: suspensions, hub, wheels and drums, rims, bearings, brakes, axles or tires.
 - The GVWR (gross vehicle weight rating) is the structural capability of the trailer when supported by the kingpin and axles with the load uniformly distributed throughout the cargo space, as defined by the Vehicle Identification Number (VIN) plate.

NOTE

The maximum load indicated on the VIN plate may or may not be a legal load on the highway you plan to use.

2. The cargo should be properly loaded, blocked and braced to prevent load shifts and to comply with the following sections of the Department of Transportation Regulations, Subpart 1 – Protection against Shifting and Falling Cargo:
 - Section 393.100 – General rules for protection against shifting or falling cargo.
 - Section 393.102 – Securement systems. To properly secure cargo, it is important that the working load limits of the tie-downs be known, as well as the working load limits of the anchor points.
 - Section 393.104 – Blocking and Bracing.
 - Section 393.106 – Front-end structure. Your trailer may or may not be equipped with a “rated” bulkhead. It is your responsibility to ensure compliance with 393.106.

Beginning March 1, 1998, all trailers are required by law to have anti-lock brake systems on at least one axle per FMVSS-121 (49CFR 571.121). A “4S-2M” system means there are 4 sensors and 2 modulator valves controlling the axles, while a “2S-1M” system is 2 sensors and 1 modulator valve. Refer to the manufacturer of the ABS system for specific information on the various components.

Decal Locations

NOTE

Decals are an important part of the trailer operation. Knowing where decals are located and what information they convey will help in the maintenance of the trailer, the safe operation of the trailer and in maintaining compliance with state and federal regulations.

NOTE

If any of these decals are missing, contact Fontaine Trailer Company for replacement information. The following decals represent the standard decals and their locations at the time of printing/trailer manufacture.

Front Decals

Front View of Trailer



Decal Locations

Side Decals

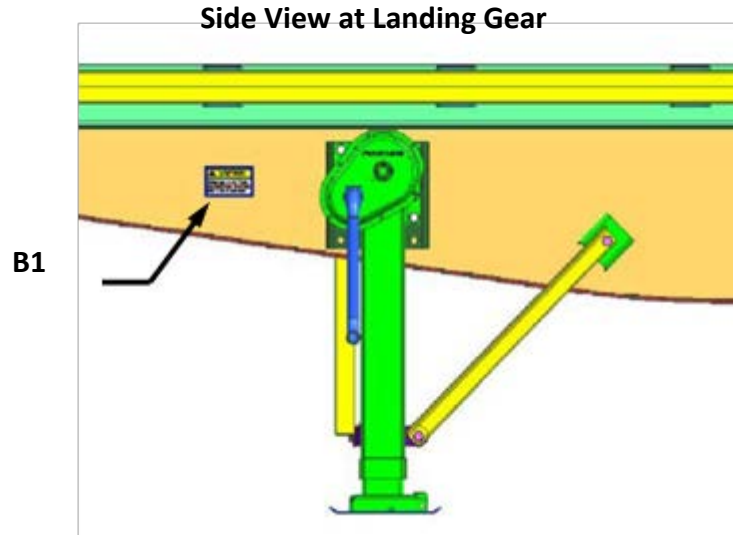

B1: The area labeled **B1** is located on the main beam web, on both the road side and the curb side, in front of the landing gear.

This decal relates to the main beams of the trailer.

Main-Beam Decal (B1)



Position B1, above: Main-Beam Decal (1 road side and 1 curb side)

Decal Locations

Side Decals, *continued*

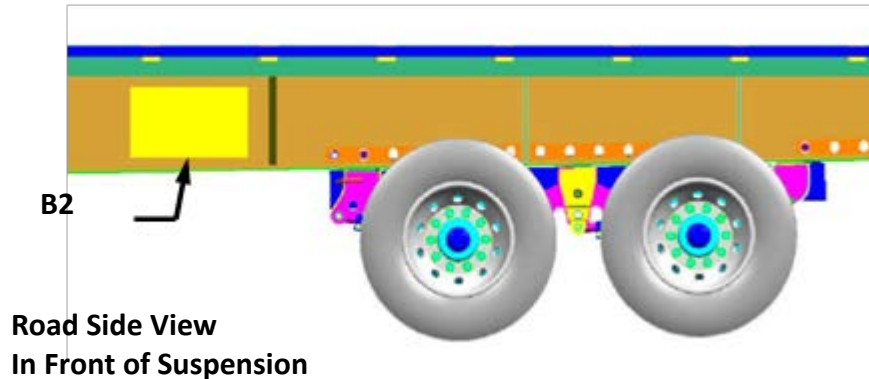

B2: The area labeled “B2” is located on the main beam web, on the road side only, in front of the foremost suspension.

Vendor decals related to the suspension or operation of the suspension are located in this area.

Examples of Decals Located In This Area

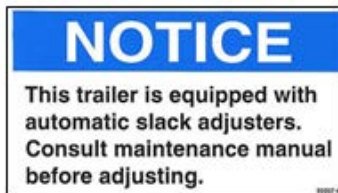

NOTE

This is only a representation of some of the decals that may be found in this area. It is not all, or the only, nor must all the ones shown be placed here. These are only examples of decals that may be found here.

Decal Locations

Side Decals, *continued*

Examples of decals that may be found in area **B2** are:

1. Fontaine: Automatic slack adjuster decal #50507065
2. Fontaine: Wheel Torque Specifications #50507097
3. Webb Wheel: Warning #SD002[©]
4. Webb Wheel: Danger Torque Specifications #SD-002[©]
5. Binkley: Suspension Maintenance Recommendations
6. Hendrickson: Suspension Torque Specifications



Side View at Landing Gear

B3: The area labeled **B3** is located on the roadside rub rail in front of the landing gear.

This decal is used on trailers with aluminum side rails, where winches are mounted onto the side rail. It shows the direction the strap is allowed to be pulled.

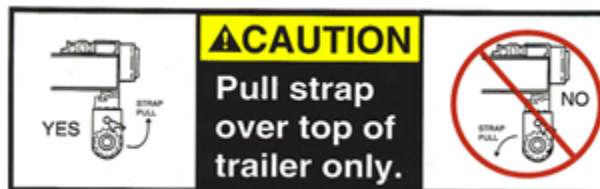

B3: Winch Strap Decal

Decal Locations

Side Decals, *continued*

Webb Wheel Decals

Webb Wheel Warning (#SD002©)



HT/HS/HK SERIES TORQUE SPECIFICATIONS

QUIK-ALIGN Pivot Bolt (2)..... 505-535 (545-627)	Shock Bolts..... 215-225 (235-218)
Welded Pivot Bolt (1/2" Dia.) 750-825 (1017-1118)	Upper Air Spring Nut..... 80-100 (100-130)
U-Bolts..... 475-525 (544-712)	Lower Air Spring Nut..... 45-55 (54-48)

1) QUIK-ALIGN Pivot Connection 2) Welded Pivot Connection

CAUTION
Do not apply additional lubricant; it can cause overclamping or fastener failure.

IMPORTANT: For QUIK-ALIGN pivot connections, a torque wrench is not required when installing a new shear-head pivot bolt and a prevailing-torque nut. During tightening, the bolts shear-head feature will shear after achieving proper torque. Use two (2-24679) QUIK-ALIGN pivot bolt kits per axle during a realignment.

HENDRICKSON
Trailer Suspension Systems

NOTICE
THIS TRAILER IS EQUIPPED WITH AUTOMATIC SLACK ADJUSTERS. CONSULT MAINTENANCE MANUAL BEFORE ADJUSTING.
FONTAINE TRAILER COMPANY, SPRINGVILLE, AL



NOTICE:
If the ABS indicator lamp comes on and stays on when you apply the brakes to a moving vehicle, the trailer ABS is not working properly. The ABS must be serviced as soon as possible upon completion of your trip to ensure full anti-lock braking capability.
39-4012 **MERITOR WABCO** Rev. 10/12

Decal Locations

Side Decals, *continued*

RIDE HEIGHT

OPERATING PROCEDURE

1. BEFORE OPERATING GOOSENECK, CHECK ENGINE OIL, FUEL TANK AND HYDRAULIC RESERVOIR FOR PROPER LEVELS BEFORE OPERATING.
2. POSITION TRAILER ON FIRM, REASONABLY LEVEL GROUND.
3. IF SELF-CONTAINED, START ENGINE AND PLACE THROTTLE IN RUN POSITION.
4. PULL OUT LOCK PIN(S) AND DISCONNECT AIR AND LIGHT CONNECTORS AT SIDE OF GOOSENECK. (SEE DIAGRAM #1)
5. WITH KINGPIN LOCKED IN TRACTOR FIFTH WHEEL, TRAILER BRAKES LOCKED AND POWER UNIT RUNNING, MOVE HANDLE OF HYDRAULIC CONTROL TO "UP" POSITION AND ALLOW GOOSENECK TO LIFT ENOUGH TO FREE THE ADJUSTABLE RIDE HEIGHT CARBON BACK OF GOOSENECK. ROTATE HANDLE "U" TO SPRING RIDE HEIGHT CARB OUT OF THE WAY. (SEE DIAGRAM #2)
6. MOVE HANDLE OF HYDRAULIC CONTROL VALVE TO "DOWN" POSITION AND LET CYLINDER RETRACT UNTIL TRAILER DECK RESTS ON THE GROUND AND PANGSHAFT "T" HAS DROPPED CLEAR OF THE PANGSHAFT HOOKS.
7. IN THIS POSITION, LOWER FRAME JACK TO SUPPORT HEIGHT OF GOOSENECK ON TRACTOR BEARER WHILE DISCONNECTING FROM THE TRAILER DECK. BEARER JACK SHOULD SUPPORT GOOSENECK SO RISER CLIFF PLATES DO NOT DRAG THE GROUND, BUT SHOULD NOT PREVENT THE PANGSHAFT FROM CLEARING THE PANGSHAFT HOOKS. (SEE DIAGRAM #3)
8. PULL GOOSENECK AWAY FROM THE TRAILER DECK. LOAD YOUR EQUIPMENT.
9. TO RECOUPLE, REVERSE THE ABOVE PROCEDURE.

UP

DOWN

DIAGRAM #1
HYDRAULIC CONTROL VALVE

DIAGRAM #2
LOWER FRAME JACK

DIAGRAM #3
TRAILER DECK RESTS ON THE GROUND AND PANGSHAFT "T" HAS DROPPED CLEAR OF THE PANGSHAFT HOOKS.

CAUTION

DO NOT OPERATE THIS UNIT UNLOADED WITH PAWL IN LOWEST NOTCH OF RACK AND RIDE HEIGHT CONTROL SET TO HIGHEST POSITION.

50506104



Decal Locations

Gooseneck Decals

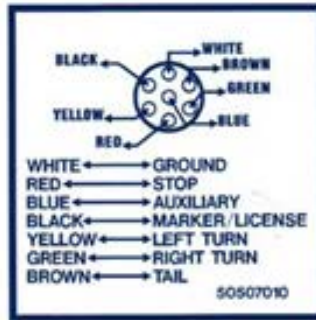

Decal Locations

Blue Wire Auxiliary Equipment Decals

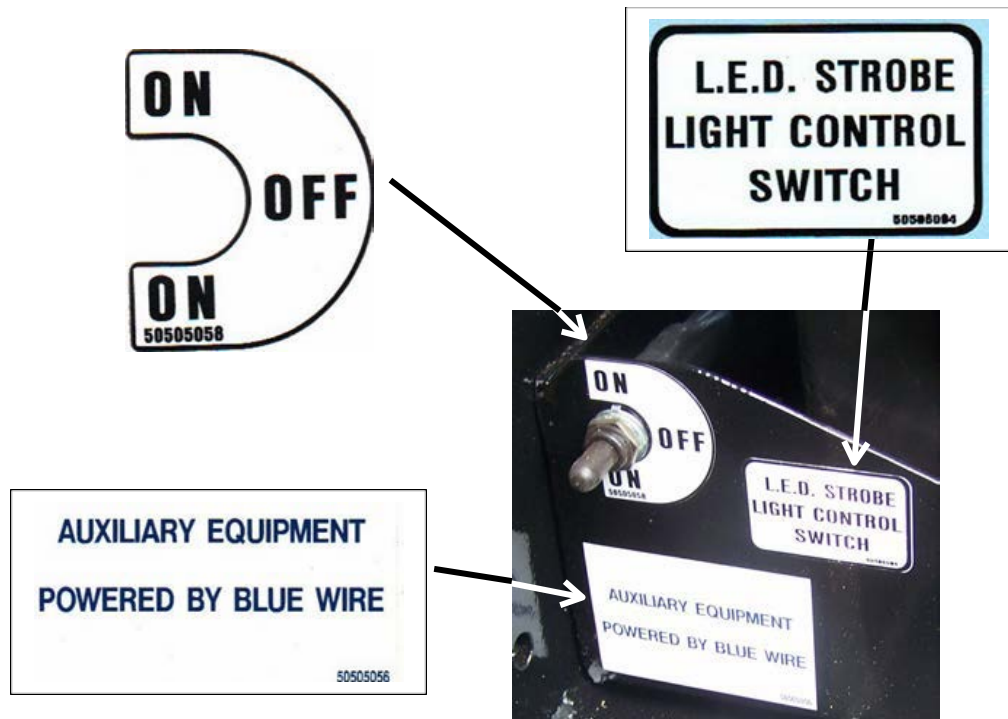

NOTICE:

If the ABS indicator lamp comes on *and* stays on when you apply the brakes to a *moving* vehicle, the trailer ABS is not working properly. The ABS must be serviced as soon as possible upon completion of your trip to ensure full anti-lock braking capability.

TP-95172 **MERITOR WABCO** Rev. 7/01



Decal Locations

ABS Decals

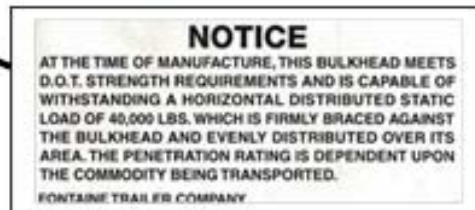

Landing Gear

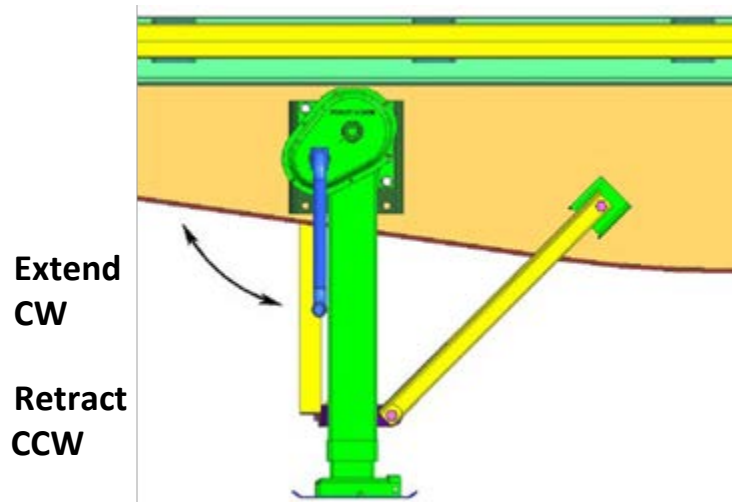

Travel Directions

Rotate crank clockwise to extend landing gear. Rotate crank counterclockwise to retract landing gear.

NOTE

Landing Gear Bolts:

Use a minimum 5/8" Grade-5 bolt on all Landing Gear connections except on cross pipe.

On cross pipe use a minimum 5/16" Grade-5 bolt.

NOTE

Torque Chart:

5/16" Grade – 5	17 Ft Lbs Dry	13 Ft Lbs Oiled
5/8" Grade – 5	150 Ft Lbs Dry	110 Ft Lbs Oiled

Landing Gear

Travel Directions, *continued*

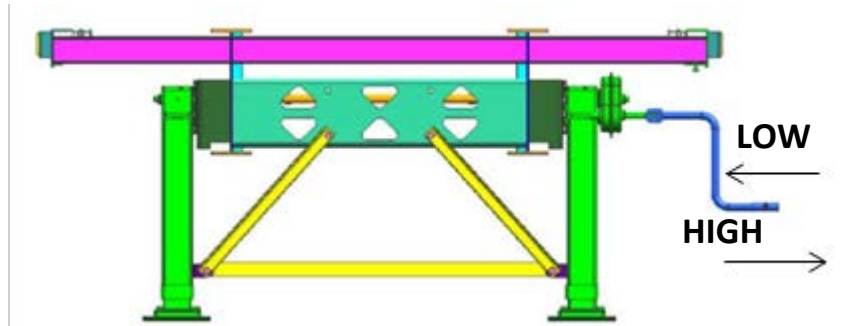

GEAR LOCATIONS:

- For low speed, extension or retraction, push crank in.
- For high speed, extension or retraction, pull crank out.



CAUTION

1. Do not over extend landing gear.
2. Never drop trailer on landing gear.
Always extend landing gear until the landing gear foot contacts the ground, then lift the trailer approximately 1 inch before removing the tractor from the trailer.
3. Always ensure that the landing gear foot rests on a hard surface capable of supporting the trailer and load (such as hard ground or concrete).

If necessary, place foot pads on a support plank to prevent the landing gear from sinking into the surface.

4. Always retract landing gear fully before moving the trailer.
5. Always store the crank in the crank holder after extending or retracting the landing gear.
6. Replace all damaged or worn parts.

Failure to replace a worn or damaged riser nut and retracting screw assembly could cause a failure.

Suspension System

Axle Alignment

Use the following procedures to check the alignment of trailer axles:

Single-Axle Trailers

1. Raise or lower the landing gear legs to put trailer in a level position.
2. Remove the outer wheels or the outer tires and rims, depending on the wheel equipment.
3. Remove any parts from under the chassis that can interrupt measuring the distance between the king pin and the ends of the axle.
4. Attach a steel measuring tape to a hook and the hook over the kingpin. Measure the distance "A" and "B" from the kingpin to the ends of the axle. The difference between the "A" and "B" measurements should be road side and curb side 1/8" (3.2mm).

Tandem-Axle Trailers

1. Measuring the alignment of a tandem-axle trailer is not very different from the procedure for a single-axle trailer. The trailer must be correctly positioned before making the necessary measurements.
2. Move the trailer forward and backward over a level floor two or three times, with the last movement forward. This allows the suspension to become correctly aligned to center the front and rear wheel tracks.
3. Raise or lower the landing gear legs to put the trailer in a level position.
4. Remove the outer wheels or outer tires and rims.
5. Remove any parts from under the chassis that can interrupt measuring the distances between the kingpin and the ends of the forward axle.
6. Attach a steel measuring tape to a hook and the hook over the kingpin. Measure the distance "A" and "B" from the kingpin to the ends of the forward axle. The difference between the "A" and "B" measurements must not exceed 1/8" (3.2mm).
7. Measure the distance "C" and "D" between the front and rear axle centers. The difference between "C" and "D" measurements must not exceed 1/16" (1.6mm).

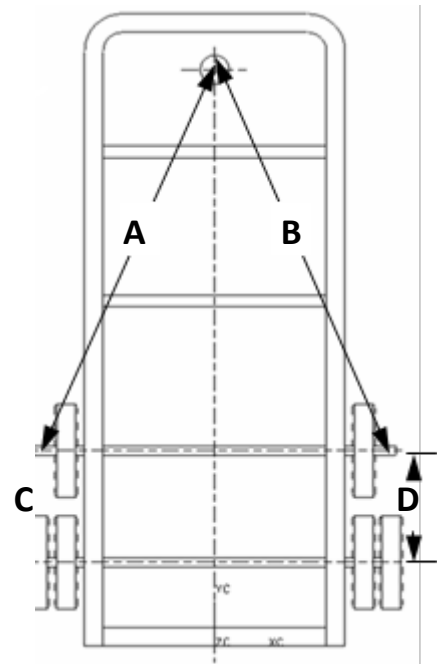

Tandem Axle Trailer

Suspension System

How to Correct the Alignment of Axles

NOTE

The limits of 1/16" (1.6mm) and 1/8" (3.2mm) are the maximum limits for correct alignment of the axles. These small limits make accurate measurements important.

To correct alignment measurements that are not within the limits, inspect the suspension for worn, broken or loose parts. Adjustment to the suspension, and the replacement of worn or broken parts, must be made to put the axles into alignment.



CAUTION

Carefully follow the service instructions made available by the suspension manufacturer when working on this component.

NOTE

See **Hendrickson Procedure I579** for more detailed information: <http://www.hendrickson-intl.com>

Checking Trailer Ride Height (Xcalibur Trailers)

Preparation

1. Unload the trailer and park it on flat, level ground that is free of stones and debris.
2. Chock the wheels (Figure 1-1).
3. Check air pressure in tires. If necessary, inflate tire to proper pressure.
4. Maintain pressure in the air system.



Figure 1-1. Wheel Chock

Designed Kingpin Height Measurement

1. Measure the trailer's kingpin height. The trailer may or may not be connected to a tractor during the measurement.
2. If necessary, adjust the landing gear to place the trailer at the designed kingpin height. The standard design kingpin height for a Fontaine Trailer is 49 inches for extendable flat and step decks. All other heavy haul models are 50 inches. Contact the Fontaine Trailer Company if you are unsure of your trailers designed kingpin height.
3. Verify the measurement of the kingpin height on the other side of the trailer.

NOTE

When the trailer and tractor are connected, the tractor's fifth-wheel height must be equal to the designed kingpin height of the trailer. If the fifth-wheel height does not equal the designed kingpin height, disconnect the tractor from the trailer.

NOTE

When the trailer is not connected to a tractor, measure the distance from the ground to the kingpin mounting plate. Air pressure to the suspension must still be maintained.

Checking Trailer Ride Height (Xcalibur Trailers)

Designed Ride Height Measurement

1. Locate the suspension ID tag on the front of the HT hanger, the front crossmember of the HS slider bogie, or on the inside of the suspension beam for the Intraax (Figure 1-2 for HT Series and Figure 1-3 for Intraax).
2. Check the indicated (underlined> number in the following examples to find the designed ride height.

HT product: HT230-14-001

HS slider: HS190T-14-4801A

Intraax: AA230TBA.I14A1A01

3. Measure the ride height (Figure 1-4). The designed ride height is the distance from the center of the axle to the mounting surface of the suspension. Measure from the bottom of the flange to the top of the axle and add half of the axle's diameter to the measurement shown on the tape measure. If necessary, adjust the height control valve.

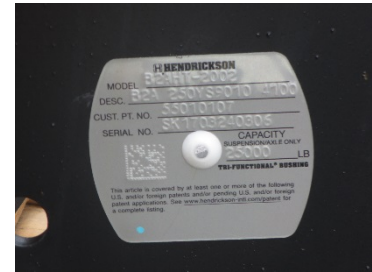

Figure 1-2. ID tag on HT suspension

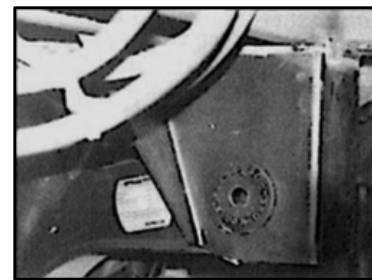

Figure 1-3. ID tag on Intraax

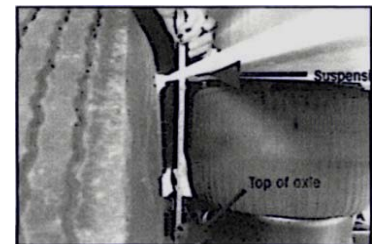

Figure 1-4. Measure ride height

NOTE

To determine the ride height, add half of the axle's diameter to the measurement shown on the tape measure. For example, a 5" diameter axle would have 2-1/2" added to the measurement.

Checking Trailer Ride Height (Xcalibur Trailers)

Height Control Valve Adjustment

1. Realign the position of the lever arm for minor adjustments of the height control valve (Figure 1-5).
2. Remove the plastic locating pin.
3. Push the control arm up to raise or down to lower the ride height until the distance between the vehicle frame and the center of the axle matches the suspension ride height.
4. After adjusting the ride height, reinsert the plastic locating pin into the adjusting block and bracket on the height control valve.
5. If additional or major adjustments are necessary, adjust or replace the linkage.



Figure 1-5. Realign lever arm

NOTE

There must be a minimum of 80 psi air pressure in the air reservoir to open the brake protection valve and allow air to flow through the height control valve.

NOTE

A 5- to 10-second delay may occur before the height control valve will allow air to flow to or from the air springs.

Suspension Ride Height Adjustment

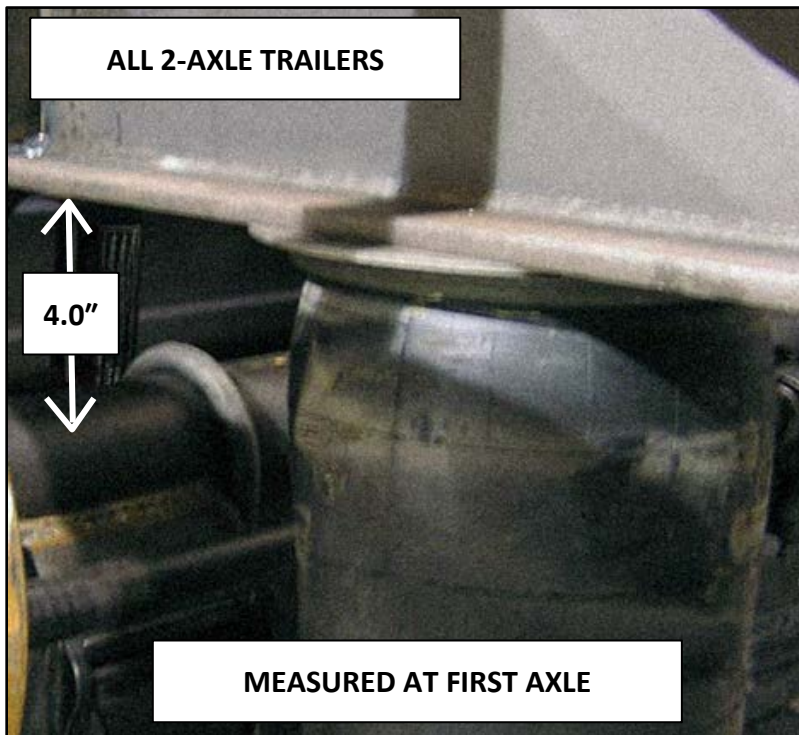
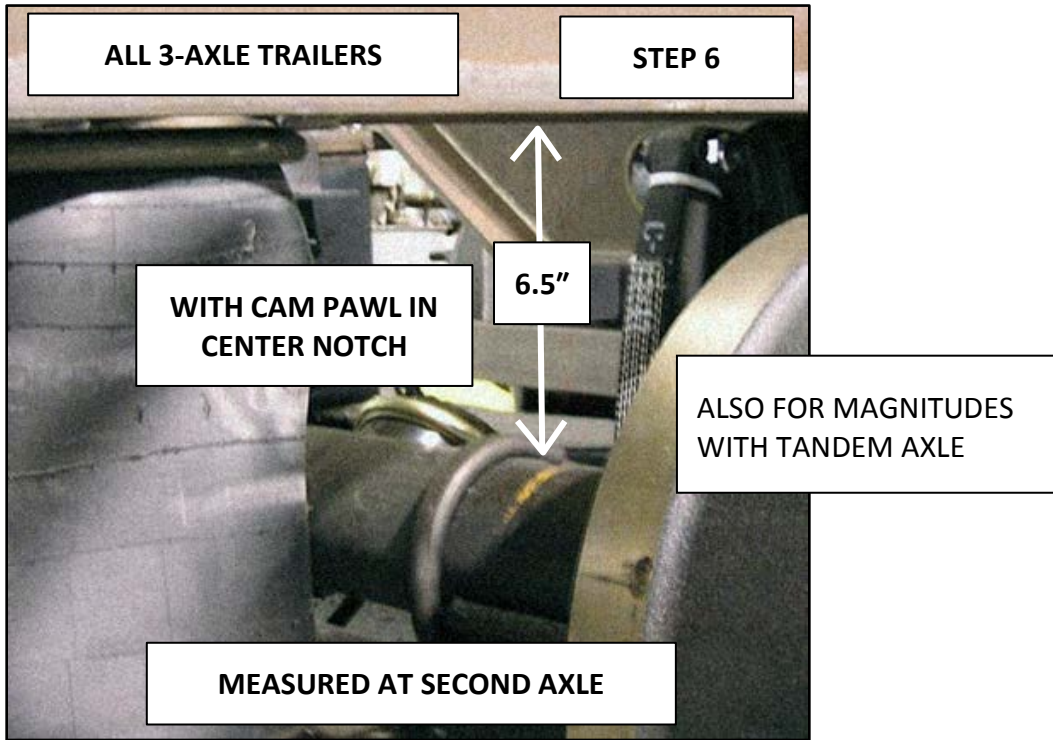

**CAUTION****ABS NOTICE—CONNECTOR WIRING CHANGE****NOTICE TO ALL TRACTOR TRAILER OWNERS AND USERS**

Federal Motor Vehicle Safety Standard No. 121, Air Brakes Systems, was amended by the National Highway Traffic Safety Administration of DOT to require that truck tractors manufactured on or after March 1, 1997, provide constant power for a trailer's Anti-Lock Brake System (ABS). Some manufacturers will provide this feature before the effective date.

These tractors using a single 7-way electrical connector will have constant power for ABS on the center pin when the key switch is on.

Fontaine, as well as other tractor-trailer owners and users who presently use the center pin for auxiliary power to equipment other than trailer ABS (for example, dome lights, backing lights, bottom dumps, sliding undercarriages, air ride dump valves, etc.) will be affected by this change.

In certain uses of this constantly powered center pin connector, unexpected or unintended activation of this equipment may be hazardous or result in personal injury.

BEFORE connecting your trailer to a tractor, MAKE SURE the constantly powered center pin WILL NOT UNINTENTIONALLY TURN ON TRAILER EQUIPMENT. If you have any questions about your present wiring or how to rewire your vehicle, you should contact the manufacturer and/or Fontaine Specialized at 1-800-633-6581.

DOT ABS REQUIREMENT *FMVSS-121 Air Brake Systems*

Anti-Lock Braking System

The Meritor WABCO Easy-Stop™ Anti-Lock Braking System (ABS) is standard on all Fontaine trailers with GVWR less than 120,000 lbs. The system monitors wheel speed at all times and improves vehicle stability and control by reducing wheel lock during braking.



CAUTION

ABS information in this Operator's Manual was provided by Meritor WABCO and is specific to its products. If your trailer is equipped with another manufacturer's anti-lock braking system, you must contact Fontaine or the manufacturer of the braking system for instructions specific to that braking system.

Electronic Control Unit (ECU) Malfunction

In the event of an ECU malfunction, the ABS in the affected wheels is disabled. The affected wheels should continue to operate in a non-ABS braking mode, if the braking valve itself has not failed. The ABS should continue to operate on the wheels unaffected by the ECU malfunction.

Two ABS indicator lamps (one on the dash of the tractor and one on the side of the trailer) let the driver know the status of the system.

ABS Indicator Lamp

The ABS indicator lamp (amber) is located on the road side (driver's side) of the trailer near the rear marker lamp (red). The lamp is identified with the letters **ABS**. This lamp indicates the status of the trailer ABS.

ABS Indicator
Lamp

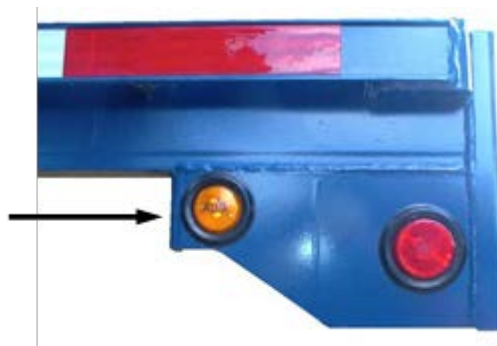

Anti-Lock Braking System

If the ABS lamp comes ON and stays ON when you apply the brakes to a moving vehicle, there is an ABS malfunction. It is normal for the lamp to come ON and go OFF to perform a bulb check, but it should not stay ON when the vehicle is moving above 4 mph. As with any safety system, it is important not to ignore this indicator. If the indicator lamp indicates a malfunction, the vehicle can be operated to complete the trip. However, it is important to have the vehicle serviced as soon as possible using the appropriate maintenance manual to ensure proper braking performance and to ensure that the benefits of ABS remain available to the driver.

System Is Ignition Powered (Constant Power)				
Brakes	Ignition	Fault in System	Vehicle Speed	Indicator Lamps (Trailer and Dash)
Released	OFF	N.A.	N.A.	OFF
	ON	NO	Less than 4 mph	ON for 3 seconds, then go OFF
	ON	NO	Greater than 4 mph	OFF
	ON	YES	N.A.	ON
Applied	OFF	NO	Less than 4 mph	ON for 3 seconds, then go OFF
	OFF	YES	N.A.	ON
	ON	NO	Less than 4 mph	ON for 3 seconds, then go OFF
	ON	NO	Greater than 4 mph	OFF
	ON	YES	N.A.	ON

Blink Codes

Blink codes are the number of times the ABS lamp blinks on and off. The number of blinks refers to the problem area. See *Meritor WABCO Maintenance and Troubleshooting Manual* for complete details:

<https://www.meritorpartsxpress.com>

Coupling and Uncoupling

Knowing how to couple and uncouple correctly is basic to safe operation of combination vehicles. General coupling and uncoupling steps are listed below. Different tractors require different techniques, so learn the details for coupling and uncoupling the tractors you operate.



WARNING

Incorrect coupling and uncoupling of your trailer can result in accidents causing serious injury or death. Not all tractors are identical. Be aware of the differences in the vehicles you operate.

Coupling and Uncoupling Procedures

1. INSPECT THE FIFTH WHEEL

- Check for damaged or missing parts.
- Check to see that mounting to tractor is secure—no cracks in frame, etc.
- Be sure the fifth-wheel plate is properly greased. Failure to do so may cause severe friction, leading to loss of control.
- Check whether the fifth wheel is in proper position for coupling (wheel tilted down toward rear of tractor, jaws open and safety unlocking handle in the automatic lock position).
- If you have a sliding fifth wheel, make sure it is locked.
- Make sure the trailer kingpin is not bent, broken or damaged in any way.

2. INSPECT AREA AND CHOCK WHEELS

- Make sure the area around the vehicle is clear.
- Be sure the trailer spring brakes are on.
- Check that all trailer cargo is secured against movement.

3. POSITION TRACTOR

- Put the tractor directly in front of the trailer.
- Check position, using outside mirrors, looking down both sides of the trailer.



CAUTION

Never back a tractor under a trailer at an angle. Pushing the trailer sideways can damage the landing gear or other structures of the trailer.

Coupling and Uncoupling

Coupling and Uncoupling Procedures, *continued*

4. BACK SLOWLY

- Back until the fifth wheel touches the trailer.
- Do not impact the trailer.

5. SECURE TRACTOR

- Apply the parking brake.
- Shift the transmission into neutral.

6. CHECK TRAILER HEIGHT

- The trailer should be low enough so that it is raised slightly by the tractor when the tractor is backed under it. Raise or lower the trailer as needed. Make sure the trailer is at the proper height and the kingpin and fifth wheel are aligned.



CAUTION

If the trailer is too high, it may not couple correctly to the tractor. If it is too low, the kingpin may be struck and bent or the front of the trailer may be damaged.



WARNING

Do not walk or stand between the tractor and trailer. Tractor movement can cause serious injury or death.

7. CONNECT AIR LINES TO TRAILER

- Check glad hand seals and connect tractor supply (emergency) air line to trailer supply (emergency) glad hand.
- Check glad hand seals and tractor control (service) air line to trailer control (service) glad hand.
- Make sure air lines are supported where they cannot be hung up or damaged while tractor is backing under trailer.

Coupling and Uncoupling

Coupling and Uncoupling Procedures, *continued*

8. SUPPLY AIR TO TRAILER

- From the tractor cab, push in “air supply” knob or move tractor protection valve control from the “emergency” to the “normal” position to supply air to the trailer brake system.
- Wait until the air pressure is normal.
- Check the brake system for crossed air lines.
- Shut the engine off to hear the brakes.
- Apply and release trailer brakes and listen for the sound of brakes being applied and released.
- Check the air-brake system pressure gauge for signs of major loss.
- When you are sure the trailer brakes are working properly, start the engine.
- Check to see that the air pressure is up to normal.

9. LOCK TRAILER BRAKES

- Pull out the “air supply” knob or move the tractor protection valve from “normal” to “emergency.”

10. BACK TRACTOR UNDER TRAILER

- Shift into lowest reverse gear.
- Back tractor slowly under trailer to avoid severely impacting the kingpin.
- Stop when the kingpin is locked into the fifth wheel.

11. CHECK THAT CONNECTION IS SECURE

- Raise trailer landing gear slightly off the ground.
- Gently pull the tractor forward while the trailer brakes are still locked.
- Fifth wheel should be locked into kingpin at this time.

12. SECURE VEHICLE

- Shift the transmission into neutral.
- Apply parking brakes.
- Shut off engine and be sure someone else will not move the truck while you are under it.

Coupling and Uncoupling

Coupling and Uncoupling Procedures, *continued*

13. INSPECT COUPLING

- Use a flashlight if necessary.
- Make sure there is no space between the upper and lower fifth wheel. If there is space, something is wrong! The kingpin may be on top of the closed fifth wheel jaws; the trailer would easily come loose.
- Look into the back of the fifth wheel with caution. Make sure the fifth wheel jaws have closed around the shank of the kingpin.
- Check that the locking lever is in the “Lock” position.



WARNING

Make sure the parking brake is engaged and the tractor cannot be moved before placing any part of your body between the tractor and trailer. Tractor movement can cause serious injury or death.

14. CONNECT ELECTRICAL CORD AND CHECK AIR LINES

- Plug the electrical cord into the trailer and fasten the safety catch.
- Check both air lines and electrical line for damage.
- Make sure air and electrical lines will not be crushed or damaged by any moving parts.
- Visually inspect to see that the ABS light functions correctly when the power cord is connected. If the light stays on or comes on during use, have the ABS unit repaired at once.

15. RAISE FRONT TRAILER SUPPORTS (LANDING GEAR)

- Use low gear range (if equipped) to begin raising the landing gear. Once free of weight, switch to high gear range.
- Raise landing gear all the way up.
- After raising the landing gear fully, secure the crankhandle.
- When full weight of trailer is resting on tractor, check for clearance between rear of tractor frame and landing gear.
- Check that there is enough clearance between the top of the tractor tires and nose of the trailer.



CAUTION

Never drive with the landing gear partially down; it could hang on railroad tracks or other objects.

Coupling and Uncoupling

Uncoupling Tractor-Semitrailers

1. POSITION RIG

- Make sure the surface of the parking area can support the weight of trailer.
- Have tractor lined up with trailer. (Pulling out at an angle can damage landing gear.)

2. EASE PRESSURE ON LOCKING JAWS

- Shut off trailer air supply to lock trailer brakes. Ease pressure on fifth wheel by backing up gently (this will help release the fifth wheel locking lever).
- Put parking brakes on while tractor is pushing against the kingpin. This will hold the rig with pressure off the locking jaws.

3. LOWER THE LANDING GEAR

- If trailer is empty, lower the landing gear until it makes firm contact with the ground, turn crank in low gear a few extra turns; this will lift some of the weight off the tractor. (Do not lift trailer off fifth wheel.) This will make it easier to unlatch the fifth wheel and easier to recouple.

4. DISCONNECT AIR LINES AND ELECTRICAL CABLE

- Disconnect air lines from trailer. Connect air line glad hands to dummy couplers at back of cab or couple them together.
- Hang electrical cable with plug down to prevent moisture from entering it.
- Make sure lines are supported so they will not be damaged while driving the tractor.

5. UNLOCK FIFTH WHEEL

- Raise release handle lock.
- Pull the release handle to the "open" position.
- Stay clear of the rear tractor wheels to avoid serious injury in the event vehicle movement.

6. PULL TRACTOR PARTIALLY CLEAR OF TRAILER

- Pull tractor forward until fifth wheel comes out from under trailer.
- Stop with tractor frame under trailer (prevents trailer from falling to ground if landing gear should collapse or sink).

7. SECURE TRAILER

- Apply parking brake.
- Place transmission in neutral.

Coupling and Uncoupling

Uncoupling Tractor-Semitrailers, *continued*

8. INSPECT TRAILER SUPPORTS

- Make sure ground is supporting trailer.
- Make sure landing gear is not damaged.

9. PULL TRACTOR CLEAR OF TRAILER

- Release parking brakes.
- Check the area, then drive the tractor clear.

Accessing Deck (Xcalibur Units Only)

Use caution when accessing the trailer deck. Enter and leave the trailer deck only from a dock as high as the trailer floor, or using a ladder or stairs. Do not attempt to use items such as lights or light brackets as “footholds” when accessing the deck. The lights or brackets may break, causing you to fall and resulting in injury to you or others.



CAUTION

Walk carefully on the trailer deck. Use caution to avoid slippery conditions that may result from water, ice, dirt, or cargo being carried.



CAUTION

Never attempt to stand or walk on the trailer deck when the trailer is moving. This could cause you to lose your balance and fall from the trailer, resulting in serious injury or death.



CAUTION

Use caution when entering or leaving the deck under wet or icy conditions. Side rails, front skirts, and tail skirts can become slippery, resulting in a fall. Falls from the trailer deck can result in serious injury or death.

Anchor Points

Working Load Limits

NOTE

All Working Load Limits (WLL) pertain to standard test results performed by Fontaine Trailer Company or a qualified testing facility.

NOTE

Anchor points describe points that are considered part of the trailer, NOT the securing devices, such as chains, cables, or straps. Securing devices must be of a sufficient design not to cut into or deform the anchor point and be rated equal to or greater than the WLL of the anchor point to obtain maximum ratings.

Customer-specified anchor points are designed for specific units and will be rated on a per-customer basis.



CAUTION

All anchor points must be visually inspected before use. If an anchor point is visibly damaged (deformed, bent, torn, ripped, cracked or any other structural defect)



WARNING

Side Rails (such as 6" structural channel or 6" extruded aluminum side rails) are not considered anchor points and should not be used as such.



WARNING

DO NOT exceed the Working Load Limits of any anchor point.

Special Anchor Points

Working Load Limits

Figures are representative of the methods used for testing standard anchor points.

Lashing Rings

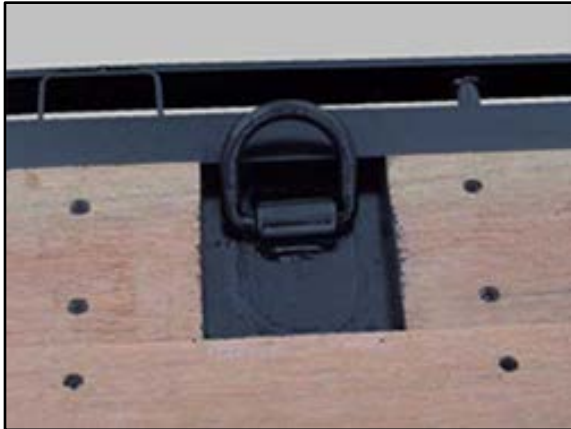

Figure 1-6. "Lashing Ring"
Recessed In Floor
WLL = 5400 lbs (2449 kgs)



Figure 1-7. "Lashing Ring"
Side Rail Mount
WLL = 5400 lbs (2449 kgs)



CAUTION

Lashing Ring Working Load Limits are for standard mountings only. Working Load Limits on lashing rings may vary with design. DO NOT exceed standard WLL without documentation of design change and rating.

Sliding Winch Xcalibur Trailers



Figure 1-8. "Sliding Winch"
(in Winch Track)
WLL = 5400 lbs (2449 kgs)

Special Anchor Points

Renegade and Magnitude Trailers

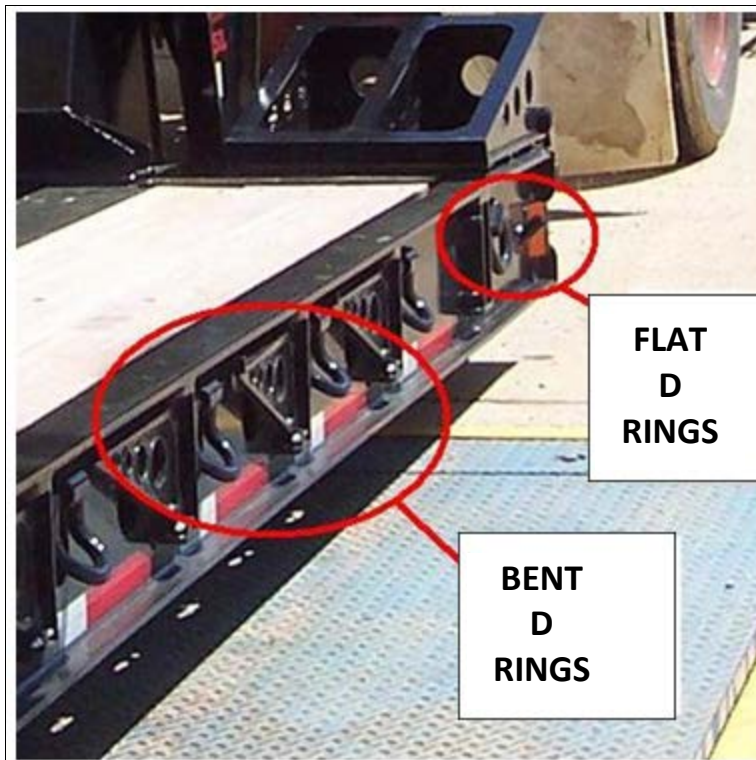

BENT D RING



FLAT D RING

STEEL WLL = 10,000 LBS (4536 KGS)

Outrigger Loads

Outrigger Loads

Lowbed trailers usually have swing-out or removable width-increasing brackets known as outriggers. They are capable of carrying loads using a plank placed longitudinally over the brackets.

Since the outriggers are spaced apart a considerable distance, no concentrated loads are permitted on them. In fact, the basic outrigger concept is for some of the load to bear on the trailer bed itself and only part of the load on the outriggers. (There are exceptions.)

Normal designs will allow for a capacity load to be supported by several outriggers acting together. The trailer crossmembers must be considered when outrigger loads approach maximum limits, since the cantilever load on the crossmember may induce severe stress on the crossmember.

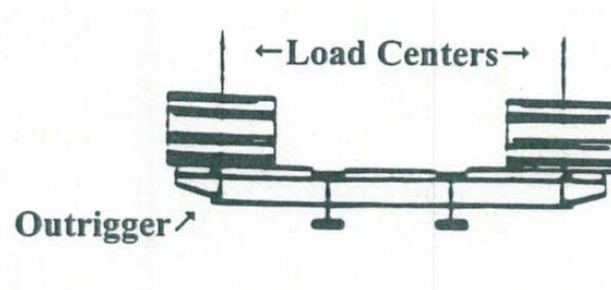

Bulkhead Securement (Xcalibur Trailers)

A Bulkhead (Header Board) is a vertical member across the front of the trailer. The Bulkhead must be secured to the trailer properly to obtain the full load rating shown on the Bulkhead nameplate. Ratings are based on FMCSA Regulations Section 393.106 – Front End Structures.

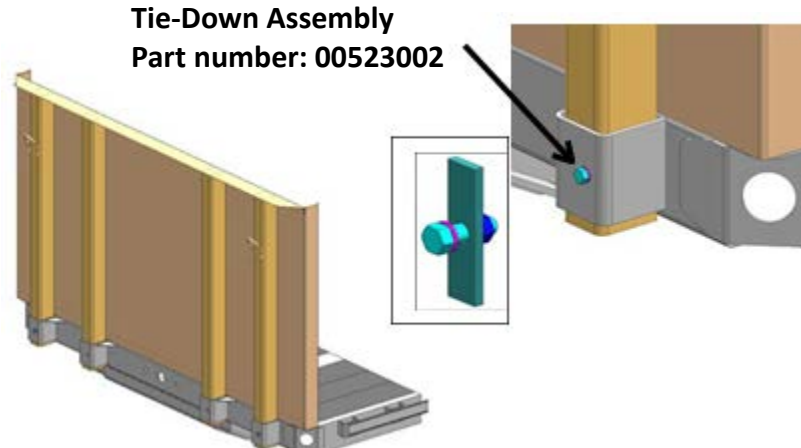

Securement Requirements

Figure 1-9. Typical Bolt-On Fontaine Bulkhead

- (2) Fontaine Tie-Down Assemblies, or
- (2) 1/2" x 1-1/2" grade 5 hex bolts, (4) 1/2" flat washers, and
- (2) 1/2" hex nuts.

The Tie-Down Assemblies (or the bolts, washers and nuts) are installed one in the road-side stake pocket and the other in the curb-side stake pocket (See Figure 1-9).

* Follow bulkhead manufacturer's instructions for non-Fontaine bulkheads.



CAUTION

The Bulkhead MUST BE SECURED before trailer is transported. Always check Bulkhead bolts during the pre-trip inspection for loose or broken bolts. Tighten any loose bolts and replace any broken, bent, or missing bolts.

Tie-Down/Bolt Torque Specifications:

1/2" GR-5 . . . 75 Ft. Lb. Dry . . . 55 Ft. Lb. Oiled

Section 2: Optional Features and Operating Instructions

Optional Features

Fontaine Heavy-Haul optional accessories are listed and shown below.

Deck Inserts



Decks Modular



Optional Features

Flip Axle

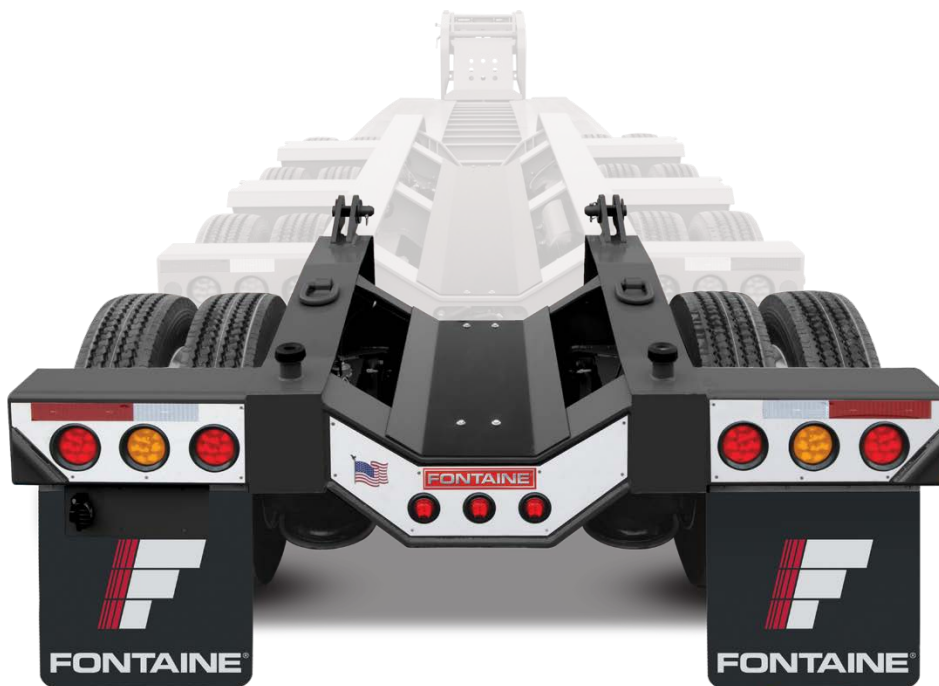

Flip Box



Optional Features

Jeep 302



Jeep 402



Optional Features

Jeep 453



Mod Connection



Optional Features

EQ2 Spreader



Fixed Spreader



Optional Features

EQ1 Spreader



Nomenclature

Magnitude Modular Trailer

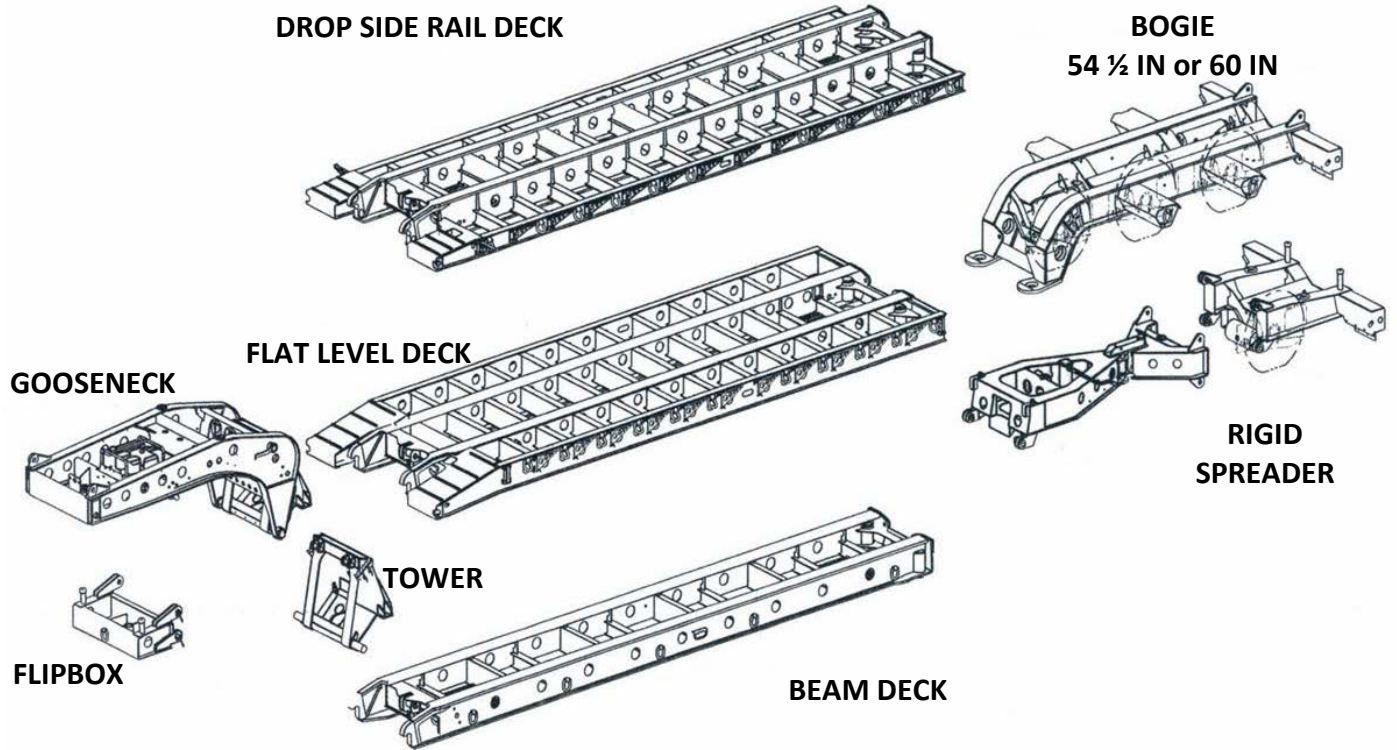

Nomenclature

Magnitude Modular Trailer, *continued*

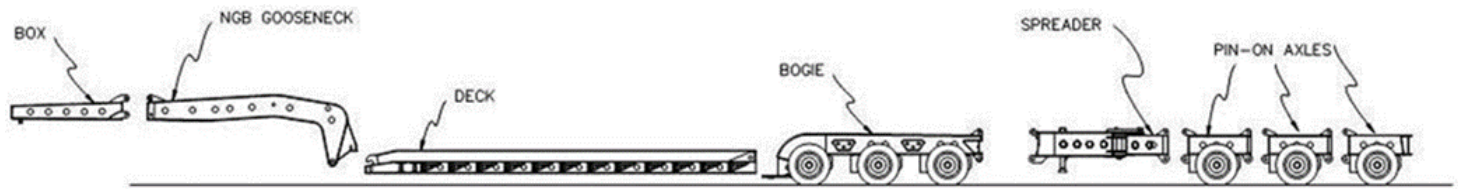

REAR DECK EXTENSION JEEP SLIDING FIFTH WHEEL REMOVEABLE PIN-ON AXLE

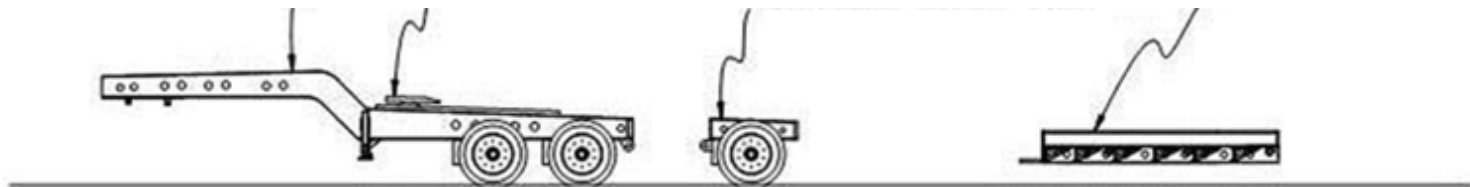

Operating Procedures

This section provides operating procedures and instructions for various Fontaine products.

Operating Procedures

Non-Ground-Bearing Operating Procedures

1. Before operating gooseneck, check engine oil, fuel tank and hydraulic reservoir for proper levels.
2. Position trailer on firm and reasonably level ground.
3. If self-contained, start engine and place throttle in run position.
4. Pull out lock pin "A" and disconnect air and light connectors at side of gooseneck (Figure 2-1).

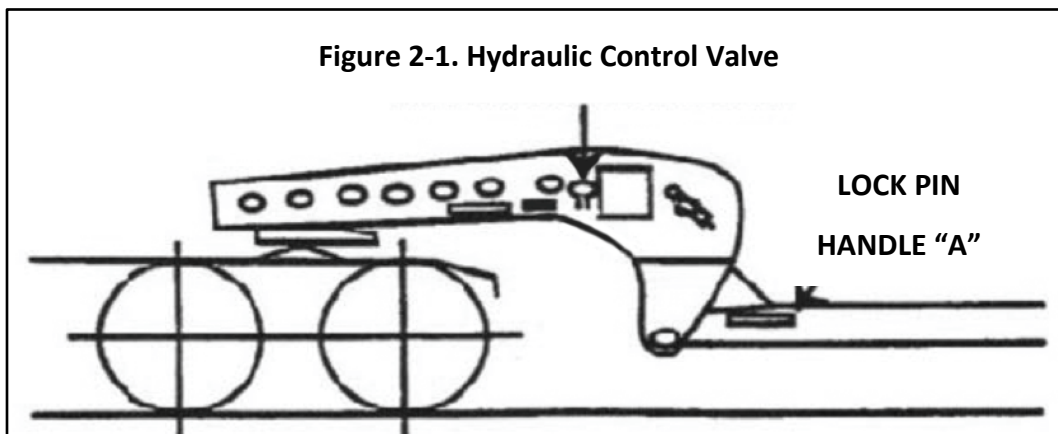

5. With kingpin locked in tractor fifth wheel, trailer brakes locked and power unit running, move handle of hydraulic control to "UP" position and allow gooseneck to lift enough to free the adjustable ride height cam at back of gooseneck. Rotate handle "D" to swing ride height cam out of the way (Figure 2-2).

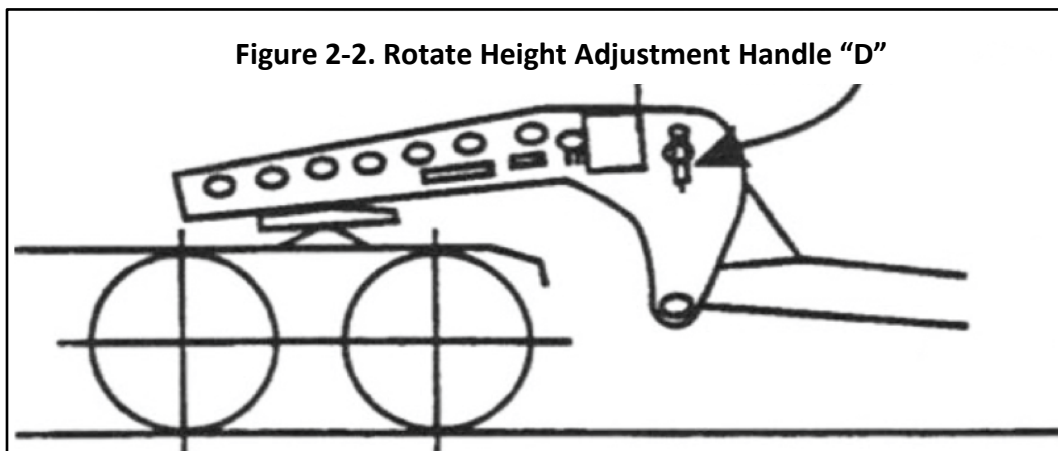

6. Move handle of hydraulic control valve to "DOWN" position and let cylinder retract until trailer deck rests on the ground and mainshaft "E" has dropped clear of the main beam hooks.

Operating Procedures

Telescoping Deck Operating Procedures



CAUTION

1. Set trailer brakes with hand valve. (Do not set parking brakes.)
2. Retract air pins located near the rear of the trailer deck on the road side. (an air switch is provided, mounted on the side of the trailer).
3. Pull forward to desired extension location.
4. Extend the air pins to lock the desired location before operating the trailer.

Manual Height Control for Trailers with Air Ride Suspensions

How to Use:

The manual height control feature is intended to be used to raise the rear axle group of the trailer in order to get over high obstacles such as a railroad pass or to lower the rear portion of the trailer to clear obstacles such as a low underpass. This feature may also be used when changing shims with a modular trailer or adding or removing axle attachments. The manual raise and lower feature temporarily disengages the automatic ride height feature and consequently is not intended for normal highway operation, but rather temporary operations.



CAUTION

The limiter straps over the shocks will not completely stop the suspension travel from over extension when using the manual height control. Caution must be observed when using this feature to its outermost extension travel. Over extension and shock strap damage will not be considered a warrantable item by Fontaine Trailer or the suspension manufacturer.



CAUTION

Do not lift the rear of the trailer off the ground without shutting off the air supply to the manual height control override. Suspension component damage may result. Axle chains or straps are present to limit axle travel when the trailer is lifted off the ground—WITH SUSPENSION CONTROL BAGS DEFLATED ONLY.

Locking Pins

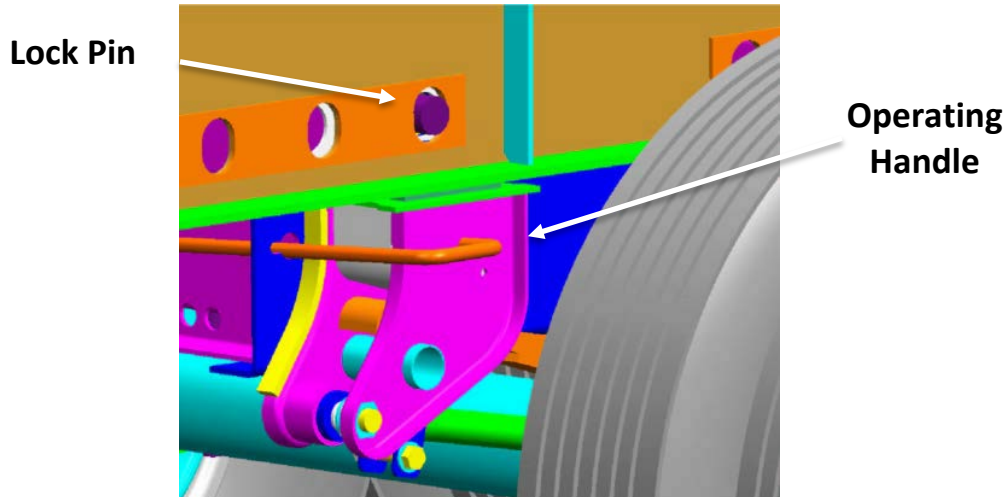

Locking Pins Procedure

1. Set both the tractor and trailer brakes.
2. Remove locator bar and place locator bar into desired hole location.
3. To release the lock pins:
 - For suspensions with manual locking pins (shown above), pull the operating handle all the way out and lock in place.
 - For suspensions with air-assisted lock pins, activate release by flipping the switch on the slide box.
4. Release the tractor brakes and carefully drive forward or backward until the sliding suspension is at the desired location.
5. Release the operating handle and visually check all lock pins for locking. The main body of each lock pin must extend through the holes in the rails.
6. Lock the locator bar in both body rails immediately behind the slider.
7. With the trailer brakes applied, gently rock trailer backward and forward to ensure sliding suspension is properly locked. Follow proper operating procedures before pulling trailer. The lock pins must be checked at each stop to ensure each is locked.

Note: Locator bars are not used on Hendrickson AAZNT air ride sliders.

Operating Procedures

Sliding Suspension (Xcalibur Trailers)



WARNING

Failure to lock a sliding suspension can cause loss of vehicle control, property damage, serious bodily injury and death. Always check to ensure that lock pins are fully engaged in the trailer frame or slider rail before use.

When a trailer is equipped with a sliding suspension, follow these procedures:

1. Make sure the suspension is securely locked into place. The suspension is locked into place when the main body of each lock pin extends through the holes in the rails.
2. Inspect the suspension carefully to ensure it is properly positioned and the main body of each lock pin does extend through the holes in the rails.
3. Check the area around and under the trailer to make sure it is clear of obstructions or personnel.
4. Apply the trailer brakes and gently rock the trailer backward and forward to make sure the sliding suspension is secure.

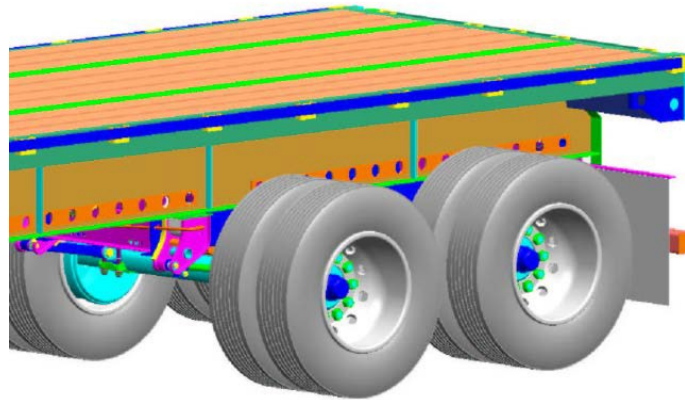

Typical Side View, at Rear of Trailer, Showing a Sliding Suspension

NOTE

Reference the suspension manufacturer's recommendations for more detailed operating instructions, cautions and warnings.

Operating Procedures

EQ1 – Hydraulic Equalizer Spreader

Safe Operation Practices

Note: This unit is not designed to travel in the raised condition. It is only intended to be used in the raised condition to aid in slow backing up situations. **Failure to follow this may result in permanent unwarrantable damage.**



WARNING

When using the hydraulic control system, it is possible to impart enough down force on the 4th axle to raise the main trailer and possible **OVERLOAD OF THE 4TH AXLE**. Remain aware of this and exercise caution until the operator becomes familiar with pressure gauge reading versus expected axle load on the 4th axle.



WARNING

When using the power unit/hydraulic pump to adjust 4th axle down force, the return circuit control valve must be in the Off position. When satisfied with the pressure setting, turn off the power unit/hydraulic pump and open the return circuit control valve.

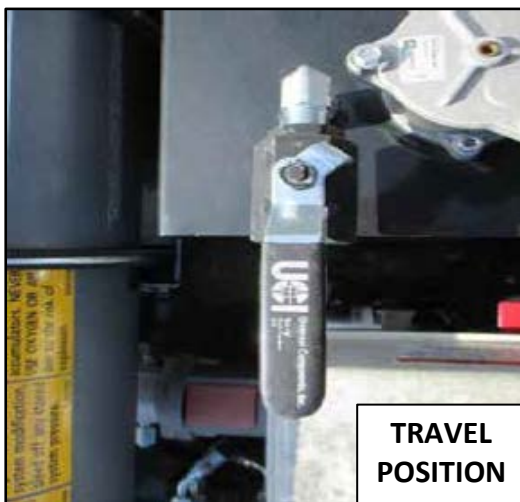

Operating Procedures

EQ1 – Hydraulic Equalizer Spreader Safe Operation Practices, *continued*

Pre-Start-Up Checks

1. Check all fluid levels: Gas, engine oil and hydraulic oil.
2. Check for any leaks—tighten fitting if required.
3. Open accumulator isolation valve.
4. Close oil return circuit valve to “Off” position.
5. Turn on engine gas supply.
6. Adjust choke and throttle as required.

Operation

1. Start Engine.
2. Adjust throttle as desired.
3. Apply fluid as required with direction valve.
4. Apply pressure as desired.
5. When desired pressure (down force) is achieved, **open** the hydraulic oil return valve and turn off the engine. A minor change in pressure is normal during this sequence.

Making Adjustments



1. Equalization occurs when all axles carry the same load.
2. The air system leveling valve also controls the bags in the 4th axle.
3. Measure the distance from the top of the axle to the top of the air bag mount on axle 2 and 4.

When this distance is within 1" of each other, your expected axle loads should be close to equal.

NOTE

The air system leveling valve takes 2 to 5 minutes to equalize when making adjustments.

Operating Procedures

EQ1 – Hydraulic Equalizer Spreader Safe Operation Practices, *continued*

Raise Feature

To raise the 4th axle, position the RETURN CIRCUIT ON/OFF VALVE TO THE “OFF” POSITION. Apply fluid to the cylinders until they are fully closed.



WARNING

When raising the 4th axle off the ground, the LOCK PIN must be fully inserted to prevent the possibility of unintended rotational movement of the spreader bar/4th axle.

LOCK PIN MUST BE INSTALLED PRIOR TO RAISING AXLE OFF THE GROUND



Backing Up Cautions

For a temporary condition, your spreader can be used to raise the 4th axle off the ground. This should be done when backing up.

If you back up with the 4th axle on the ground and the lock pin IS NOT INSTALLED, it will be extremely easy to jackknife the 4th axle/spreader bar.

If you back up with the 4th axle on the ground and the lock pin IS INSTALLED, you will probably skid/scuff the 4th-axle tires, and further possible permanent damage may result.

Note: This feature is not intended for normal highway transport mode. Failure to follow this may result in permanent unwarrantable damage.

Operating Procedures

EQ1 – Hydraulic Equalizer Spreader Safe Operation Practices, *continued*

This unit is equipped with a HONDA Gas Powered Engine. For all safety, maintenance, parts, service and operational procedures, please refer to the Honda manual (attached).

Operating Procedures

EQ1 – Hydraulic Equalizer Spreader Safe Operation Practices, *continued*



WARNING

When backing the trailer and 4th axle with the HES unit in place, the lock pin must be engaged and the 4th axle must be raised off the ground. Failure to do this may result in personnel injury or cause unwarrantable structure damage.

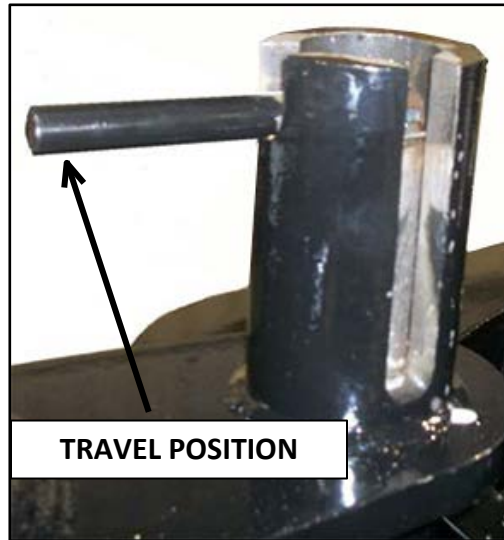
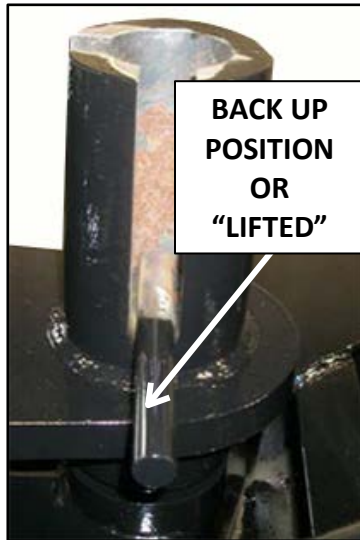

WARNING

This unit is equipped with a Hydraulic Accumulator. This device is factory pre-charged to 900 psi with pure NITROGEN. If a loss of pressure occurs or a higher pre-charge is desirable, ONLY PURE NITROGEN GAS CAN BE USED. See accumulator manufacturer's brochure for more detailed information.



WARNING

This unit has a pre-charged Hydraulic Accumulator. BEFORE REMOVING A HYDRAULIC HOSE OR COMPONENT, the stored energy in the accumulator must be released or isolated to the accumulator itself by using the "Off" position of the Accumulator Safety Valve.

Operating Procedures

EQ1 – Hydraulic Equalizer Spreader Safe Operation Practices, *continued*

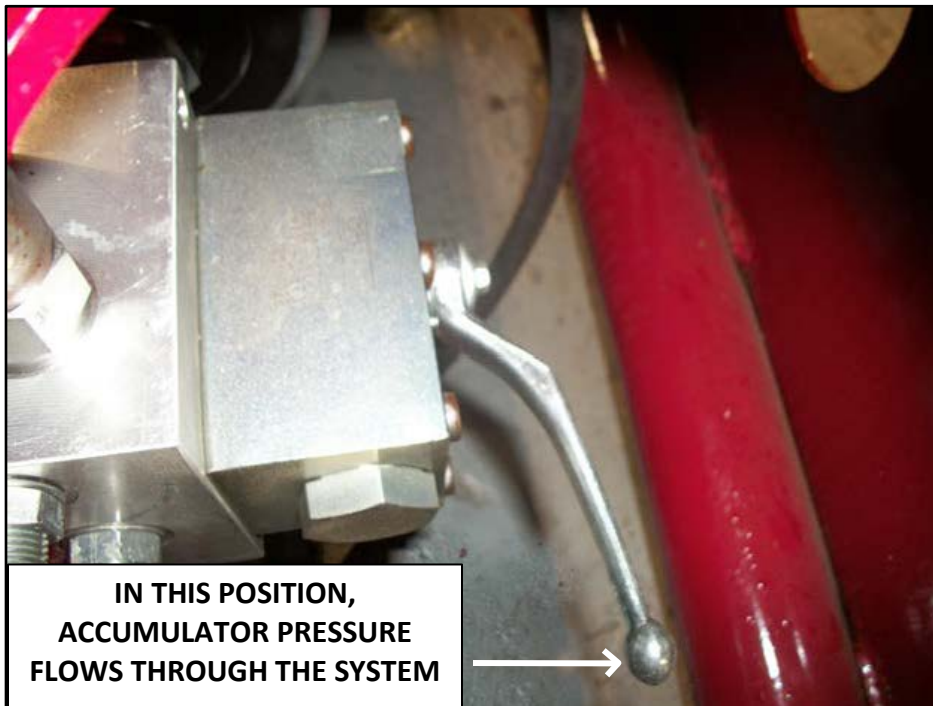

Operating Procedures

EQ1 – Hydraulic Equalizer Spreader Safe Operation Practices, *continued*

1. The system operating pressure is varied by application of hydraulic down force on the rear two axles.



- a. **Error! Reference source not found.** below is the single-spool main cylinder operation valve. This valve is used to raise or lower the rear two axles (change pressure—down force). The valve has an adjustable relief cartridge that can be set to the desired bypass point.

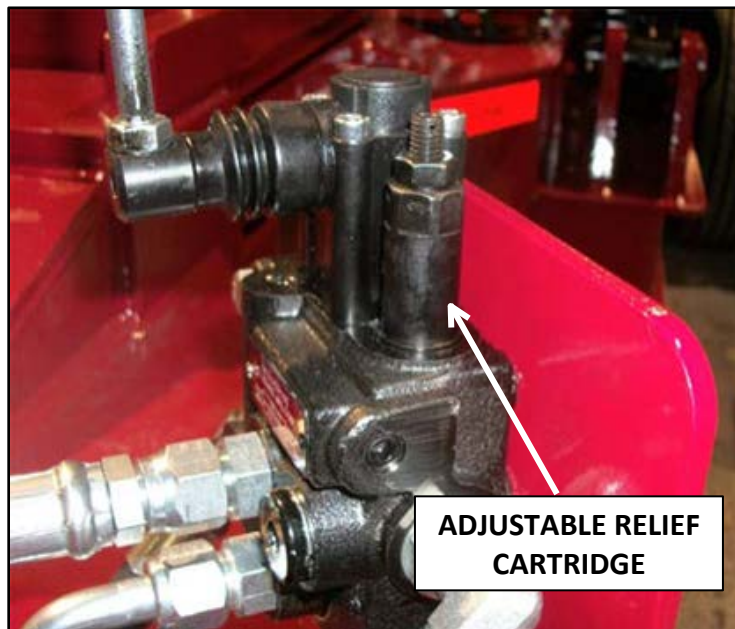

Figure 2-3. Single-Spool Main Cylinder Operation Valve

Operating Procedures

EQ1 – Hydraulic Equalizer Spreader, Safe Operation Practices, *continued*



WARNING

This unit has a pre-charged Hydraulic Accumulator. Prior to removing a hydraulic hose or component the stored energy in the accumulator must be released or isolated to the accumulator itself by using the "Off" position of the Accumulator Safety Valve.

NOTE

This unit is not designed to travel in the raised condition. It is only intended to be used in the raised condition to aid in slow backing up situations. **Failure to follow this may result in permanent unwarrantable damage.**



WARNING

When using the hydraulic control system, it is possible to impart enough down force on the 4th axle to raise the main trailer and possible (OVERLOAD THE 4TH AXLE). Remain aware of this and exercise caution until the operator becomes familiar with pressure gage reading versus expected axle load on the 4th axle.



WARNING

When using the power unit/hydraulic pump to adjust 4th axle down force, the return circuit control valve must be in the "Off" position. When satisfied with the pressure setting, turn off the power unit/hydraulic pump and open the return circuit control valve.



Operating Procedures

EQ1 – Hydraulic Equalizer Spreader, Safe Operation Practices, *continued*

This unit is equipped with a HONDA Gas Powered Engine. For all safety, maintenance, parts, service and operational procedures please refer to the Honda manual (attached).



WARNING

When raising the 4th axle off the ground, the LOCK PIN must be fully inserted to prevent the possibility of unintended rotational movement of the spreader bar/4th axle.

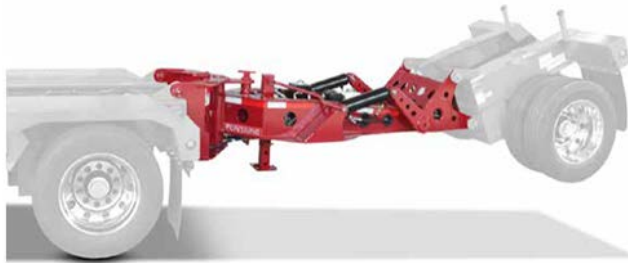

LOCK PIN MUST BE INSTALLED PRIOR TO RAISING AXLE OFF THE GROUND



WARNING

This unit is equipped with a Hydraulic Accumulator. This device is factory pre-charged to 700 psi with pure NITROGEN. If a loss of pressure occurs or a higher pre-charge is desirable, **ONLY PURE NITROGEN GAS CAN BE USED**. See accumulator manufacturer's brochure for more detailed information.



WARNING

This unit has a pre-charged Hydraulic Accumulator. Prior to removing a hydraulic hose or component the stored energy in the accumulator must be released or isolated to the accumulator itself by using the "off" position of the Accumulator Safety Valve.

Operating Procedures

EQ1 and EQ2 – Nitrogen Equalizer Systems

EQ1 and EQ2 Series

Nitrogen Equalizer System—3+1 and 3+2 Configuration

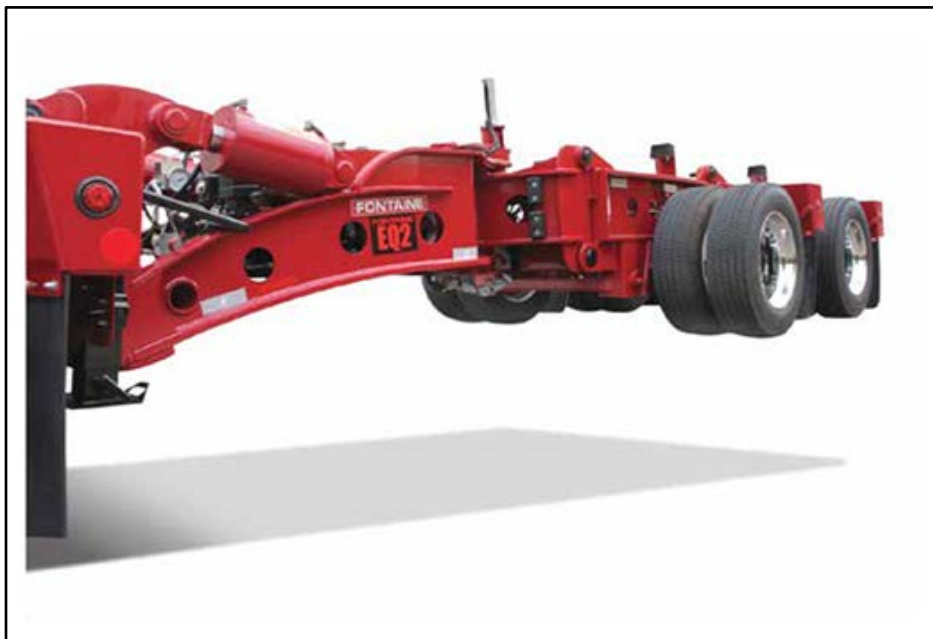

Operating Procedures

EQ1 – Hydraulic Equalizer Spreader, *continued*

Raise Feature



For a temporary condition, your spreader can be used to raise the 4th axle off the ground. This should be done when backing up.



WARNING

When raising the 4th axle off the ground, the LOCK PIN must be fully inserted to prevent the possibility of unintended rotational movement of the spreader bar/4th axle.

To raise the 4th axle, position the RETURN CIRCUIT ON-OFF VALVE TO THE “OFF” POSITION. Apply fluid to the cylinders until they are fully closed.

Backing Up Cautions

If you back up with the 4th axle on the ground and the lock pin NOT INSTALLED, it will be extremely easy to jackknife the 4th axle/spreader bar.

If you back up with the 4th axle on the ground and the lock pin INSTALLED, it will be likely that you will skid/scuff the 4th axle tires and further possible permanent damage may result.

Note: This feature is not intended for normal highway transport mode. Failure to follow this may result in permanent unwarrantable damage.

Operating Procedures

EQ2 – Hydraulic Equalizer System

Operating Instructions for Accumulator Service ONLY

C. Releasing Accumulator Pressure—Oil or Nitrogen

1. The tractor must be connected (hydraulics) to the trailer.
2. To release system (oil) pressure open both shut-off valves with the manual shut-off lever.

Then release oil pressure from accumulators by moving the control valve handle. The indicator gauge must show 0 (zero) pressure.

3. To charge or release “nitrogen” see following pages for instructions.

System Pre-Set Pressures

Control valve is pre-set to: 2500 psi

Safety valves are pre-set to: 3000 psi

For 2 + 2 or 3 + 2 trailers only:

*Nitrogen accumulators pre-charge: 900 psi

Oil operating pressure (8" bore cylinders): 1150 psi

Operating Procedures

EQ2 – Hydraulic Equalizer Spreader Operating Instructions

1. The backup pin must be inserted when raising the rear axles off the ground or backing up. This pin **MUST BE OUT** when in the travel mode.

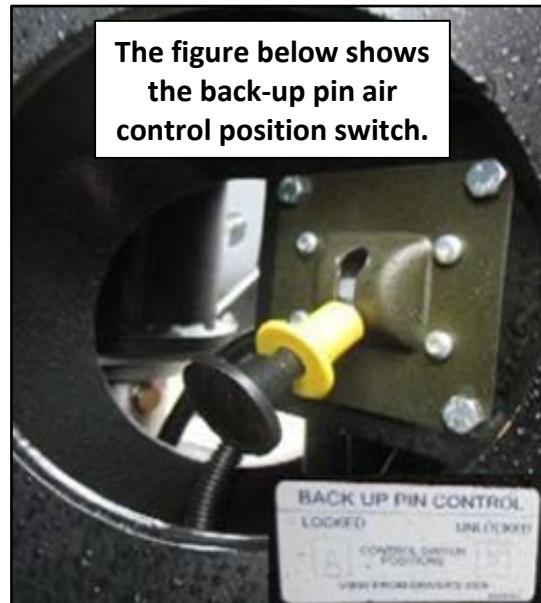

- a. Figure 2-4 below shows the accumulator safety valve with the handle in the "Off" position, the accumulator pressure is isolated from the rest of the system.

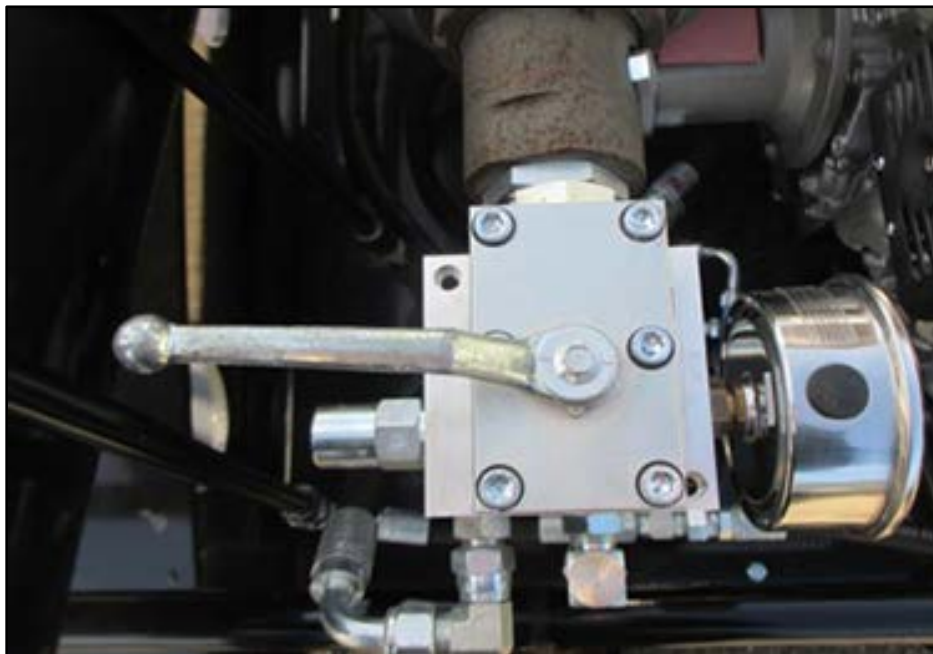

Figure 2-4. Accumulator Safety Valve In "Off" Position

Operating Procedures

EQ2 – Hydraulic Equalizer Spreader Operating Instructions, *continued*

- a. The On/Off shut-off valve is for the cylinder tank return circuit. When the valve handle is in the position shown, the hydraulic cylinder down force adjustment can be made. When lifting, once the desired position is obtained, turn the pump to the “Off” position and open this valve for “Travel Position.”



- b. The On/Off shut-off valve for the cylinder tank return circuit shown in the “Travel Mode.”



Operating Procedures

EQ2 – Hydraulic Equalizer Spreader Operating Instructions, *continued*

- a. Figure shows the lift axle chain (both sides).

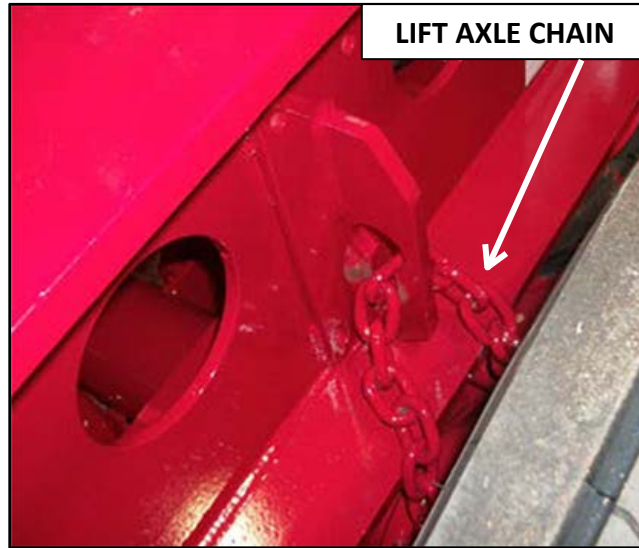

- b. Figure 2-5 below shows the air suspension On/Off valve. To lift the axle, dump all the air in the suspension chain up the axle. To lower, close off the valve to air the suspension back up.

Also shown is the air system push/pull dump valve and the strobe light On/Off switch.

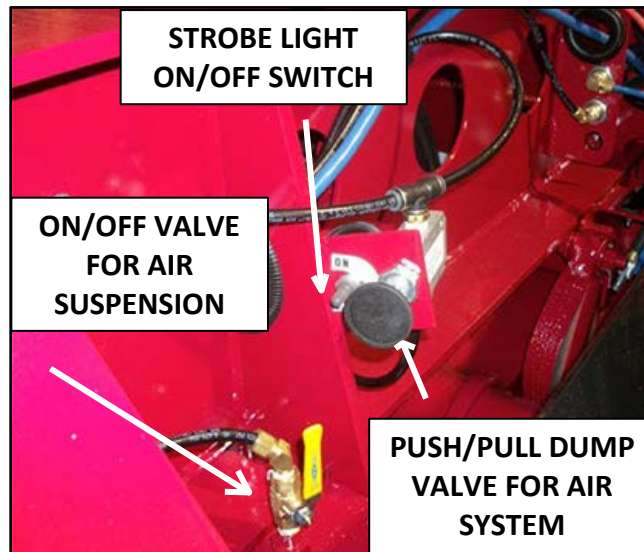

Figure 2-5. Air Suspension On/Off Valve

Operating Procedures

EQ2 – Hydraulic Equalizer Spreader Operating Instructions, *continued*

- a. Figure 2-6 shows the ride height adjustment arm.



Figure 2-6. Ride Height Adjustment Arm

- b. Figure 2-7 below shows the valve that controls the bottom air lock pins.

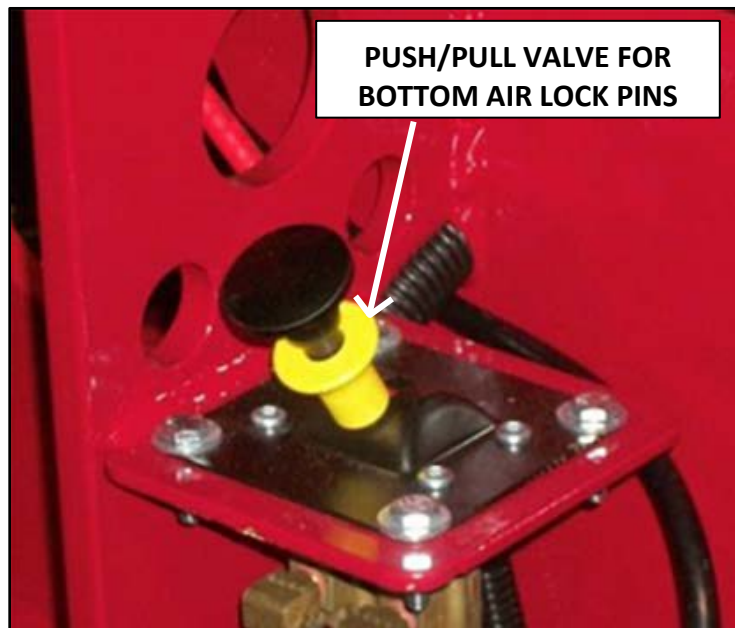

Figure 2-7. Bottom Air-Lock Pin Valve

Operating Procedures

EQ2 – Hydraulic Equalizer Spreader Operating Instructions, *continued*

- c. Figure 2-8 below shows the fine adjustment handle used for the drop leg landing gear.



Figure 2-8. Drop Leg Landing Gear Adjustment Handle

- d. When lifting the rear two axles off the ground, the backup pin must be fully inserted to prevent the unintended swing movement, if on uneven ground. To raise, put supply air ON, chain up both rear axles, position ride height in highest position, and drop the front of trailer as low as possible.



Operating Procedures

EQ2 – Hydraulic Equalizer Spreader Operating Instructions, *continued*

With Trailer Loaded

1. Connect gooseneck to trailer, jeep and tractor.
2. Connect all air and hydraulic lines to tractor.
3. Open manual shut-off valve lever (turn 90 degrees) on both accumulators (see DWG item #3), Close tank ball valve to set pressure.
4. Start tractor PTO (or self-contained power unit), the indicator on the gauge (on safety valve, see DWG item # 4) will indicate an increase in pressure. System is now charged with oil.
5. Equalize all axles by moving the control lever.

To check equalization, measure distance from bottom of frame to ground at each axle, air bag.

When all axle-to-ground distances are approximately the same, system is equalized and ready to go.

Once equalized, shut off PTO (or power unit). And open tank ball valve.

Unloading Trailer

1. Shut off manual control valves (turn 90 degrees) on both accumulators.
2. Pull the gooseneck lock pin. Drop the gooseneck down to the ground and disconnect all air and hydraulic lines at the gooseneck to deck connectors. Remove gooseneck per instructions.
3. Dump air bags on all axles.
4. Off load equipment.

NOTE

The trailer will “uncoil” due to camber and rear pitch designed into trailer. This is normal for this type of trailer.

To operate the trailer when empty, air up the system, use hydraulic control valve to level out the trailer per procedure in Step A.

Operating Procedures

EQ2 – Hydraulic Equalizer System Pressure Dump Switch

Adjust trigger bolts to desired maximum. Turn angle before down-force hydraulic pressure dumps.

NOTE

This is a vehicle safety device and it is **NOT RECOMMENDED TO BE BYPASSED**.



Operating Procedures

EQ2 – Hydraulic Equalizer System Maintenance



CAUTION

OIL SIDE OF ACCUMULATORS: Prior to performing any repairs, maintenance, or modifications, bleed off any stored system oil pressure. See section for releasing oil pressure in the system.



CAUTION

NITROGEN SIDE OF ACCUMULATORS: If repairs or replacement of the nitrogen side "bladder" is required, bleed off all system oil pressure as noted above and all nitrogen pressure. The nitrogen can be released with a charge and test kit. (Optional item.)

Maintenance intervals:

- **Daily:** Check for hydraulic leaks.
- **Monthly:** Check nitrogen pressure with charge and test kit for any drop-in pressure.
- **Every Six Months:** Power Unit Operation—Replace filter (oil filter) located on the power unit.
- **Every Six Months:** Wet-Line Operation—Replace filter element (oil filter) located on pressure side of hydraulic line in the gooseneck. See instructions for replacement.

Operating Procedures

Nitrogen Pressure and Charging

Checking Nitrogen Pressure and Charging

Follow the steps below to check accumulator tank pressure and charge the tanks as needed:

1. Locate the accumulator tank or tanks. See illustration below.



2. Turn the accumulator safety valve or valves to the **Closed** position.

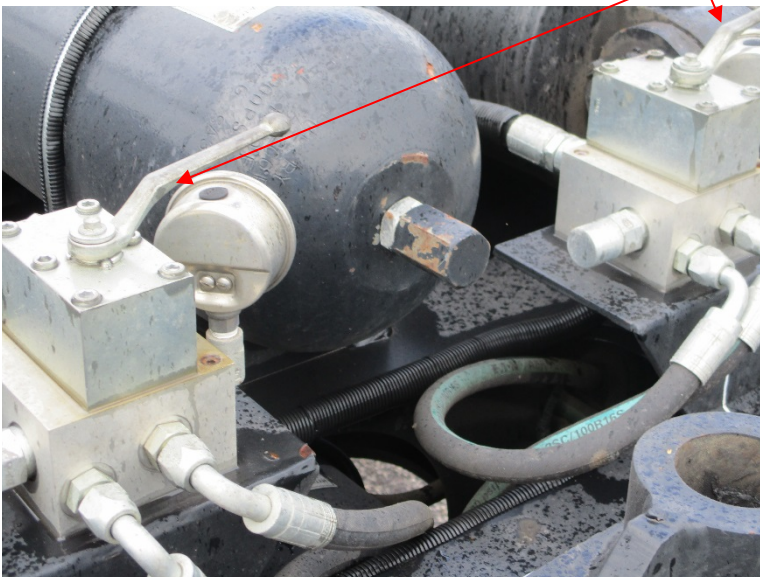

Operating Procedures

Checking Nitrogen Pressure and Charging, *continued*

1. Remove the Cap from the accumulator.

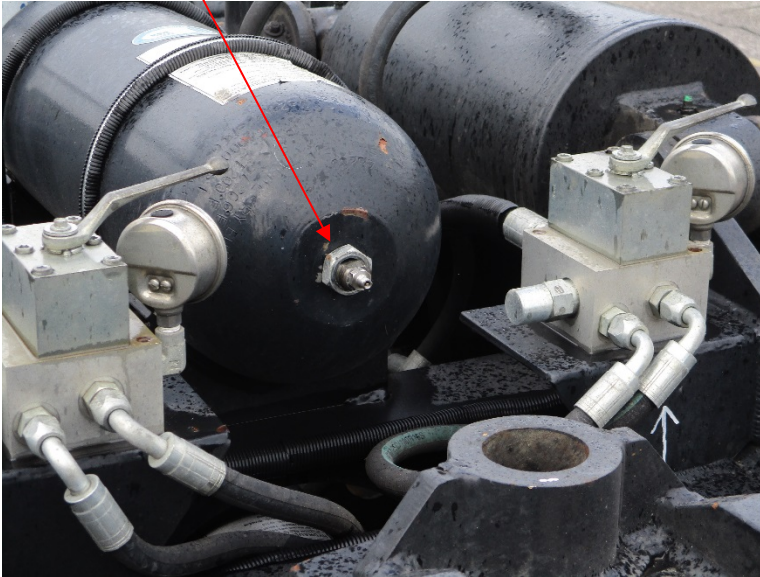

2. Take the Gauge out of the accumulator charge kit.



Operating Procedures

Checking Nitrogen Pressure and Charging, *continued*

3. Hook the Gauge to the accumulator outlet to check the pressure reading.



Operating Procedures

Checking Nitrogen Pressure and Charging, *continued*

- To charge the bottle, use the hose provided and a Compressed Nitrogen bottle as shown below.



- Fill the bottle to the appropriate pre-charge settings of:
 - EQ1 pre-charge pressure = 700 psi
 - EQ2 pre-charge pressure = 900 psi
 - EQ3 pre-charge pressure = 1250 psi

Operating Procedures

Power Unit (13HP) Installation

Follow the steps below to install the optional 13HP Power Unit:

1. Lift the power unit using a strap around the center bar as shown below.



2. Place the power unit into the gooseneck with the fuel tank on roadside on the attachment slots.



Operating Procedures

Non Ground-Bearing Gooseneck – Frame Jack Operation

In this position, lower frame jack to support weight of gooseneck on tractor frame while disconnecting from the trailer deck. Frame jack should support gooseneck, so riser cliff plates do not drag the ground, but should not prevent the main shaft from clearing the main frame hooks, see

- a. Figure 2-9.

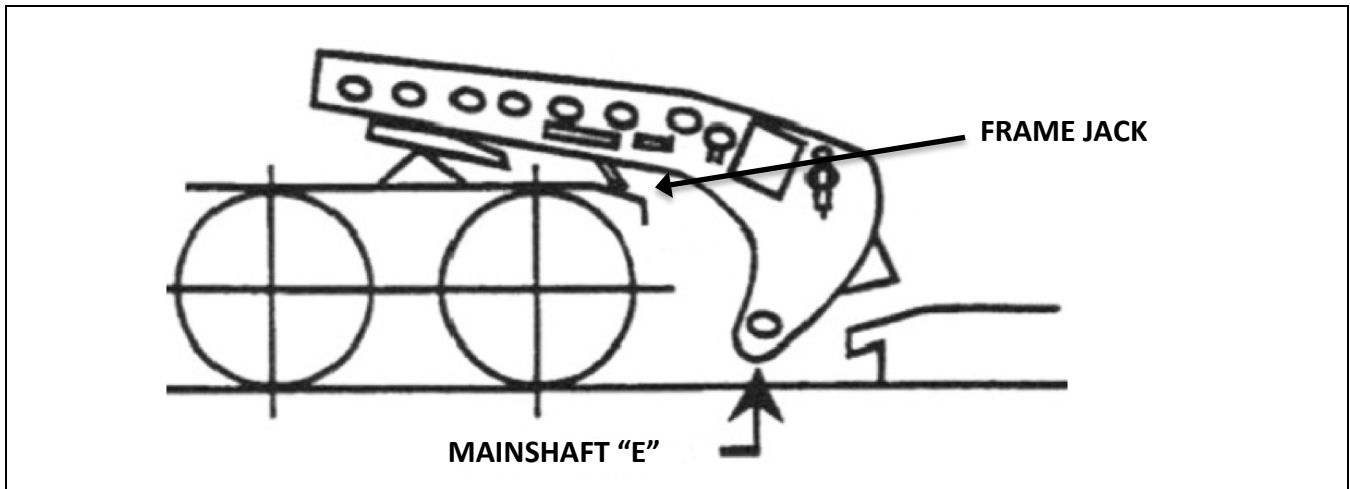
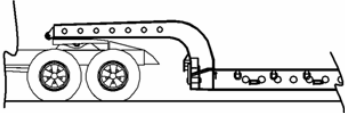
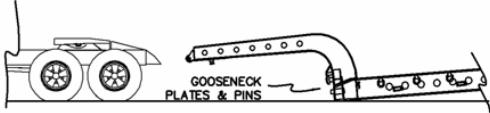
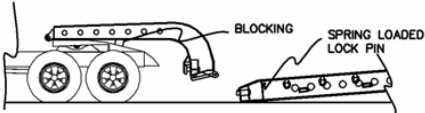
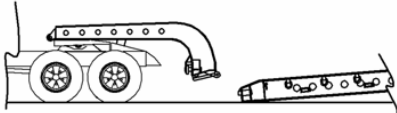
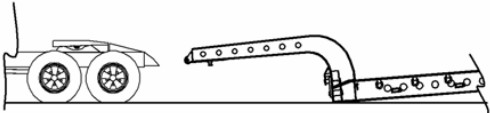
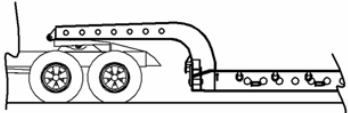

Figure 2-9. EQ2 Mainshaft

- b. Pull gooseneck away from the trailer deck. Load your equipment.
- c. To recouple, reverse steps 1 thru 8.

Operating Procedures

Mechanical – Removable Gooseneck Operation

<p>1. ROAD TRAVEL POSITION. TO LOWER DECK & REMOVE GOOSENECK, UNLOCK 5TH WHEEL, SET TRAILER BRAKES, & PULL TRACTOR AHEAD SLOWLY, LETTING GOOSENECK ROLLERS DOWN RAMP. NOTE: IF RAMP ARE LONG ENOUGH (AS SHOWN) NO BLOCKING IS NEEDED UNDER DECK.</p> 	<p>2. ROLLERS FREE OF RAMP, GOOSENECK PLATES CAN NOW BE REMOVED FROM LOWER PINS BY REMOVING AND STORING "U" BARS. ROTATE PLATES TO HORIZONTAL POSITION & HOOK TO CHAINS.</p> 
<p>3. BACK TRACTOR UP UNTIL 5TH WHEEL LOCKS ON GOOSENECK KINGPIN. PULL OUT SPRING LOADED LOCK PIN, ENGAGING DETENT TO HOLD RETRACTED. BLOCK BETWEEN GOOSENECK FRAME AND TRACTOR WITH SUITABLE TIMBER (FOR I.E., 4"x6") DISCONNECT LINES BETWEEN GOOSENECK & DECK. PULL AWAY WITH GOOSENECK & LOAD TRAILER.</p> 	<p>4. TO RECOUPLE GOOSENECK: DISENGAGE SPRING LOADED LOCK PIN FROM DETENT & PLACE IN AUTOMATIC POSITION. BACK TRACTOR INTO DECK SQUARELY SO THAT GOOSENECK GUIDE ENGAGES & LOCKS TO DECK.</p> 
<p>5. UNLOCK 5TH WHEEL, PULL FORWARD UNTIL ROLLERS ARE FREE FROM RAMP. UNHOOK PLATES FROM CHAINS, PLATES CAN NOW BE REPLACED OVER LOWER PINS BY REPLACING "U" BARS PIN & CLIP "U" BARS SECURELY. CONNECT LINES BETWEEN GOOSENECK AND DECK.</p> 	<p>6. BACK TRACTOR UNDER ROLLERS, LIFTING TRAILER, BE SURE 5TH WHEEL LOCKS. FREE TRAILER BRAKES, READY FOR TRAVEL.</p> 

Operating Procedures

Load Characteristics – Double Drop Extendables

12" 12"

CAPACITY IN ANY OPEN POSITION IS EQUAL TO RATED CAPACITY LOAD BASE (DECK LENGTH - 24')

LOCATION OF EXTENSION AIR LOCK SWITCH

MAXIMUM RATED CAPACITIES

MODEL	EXTENDED POSITION	CONCENTRATED IN	LOAD IN POUNDS	* SELF SUPPORTED
LXT40	CLOSED	16'-0"	80,000	NO
	ALL OPEN POSITIONS	SEE ABOVE	80,000	YES

NOTE
 * WHEN THE TRAILER IS EXTENDED, THE LOAD ITSELF WILL BE REQUIRED TO SUPPORT THE DECK BY MEANS OF STRAPS, CHAINS, ETC. TO KEEP THE DECK FROM DROPPING BELOW ITS LEVEL CONDITION

Operating Procedures

Deck Extensions Operations

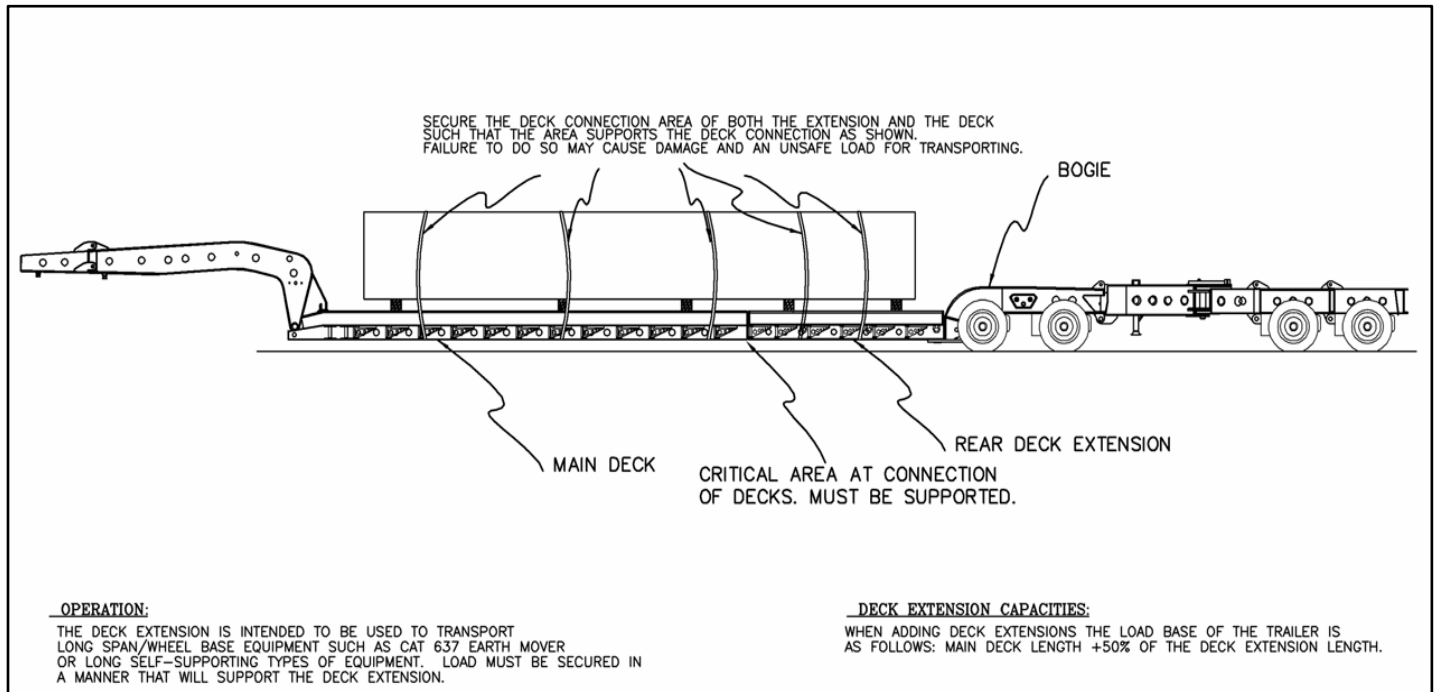

Operating Procedures

Shim Points and Applications

SHIM REQUIREMENTS: (FIGURE 1)
1. DIFFERING LOADS, TRUCKS, AND LOAD POINTS,
EFFECT SHIM REQUIREMENTS

- 2. SOME EXPERIMENTATION WITH DIFFERENT SHIMS MAY BE REQUIRED
- 3. BY SELECTIVELY SHIMMING AT "SHIM" POINT,
DECK HEIGHT MAY BE ADJUSTED.

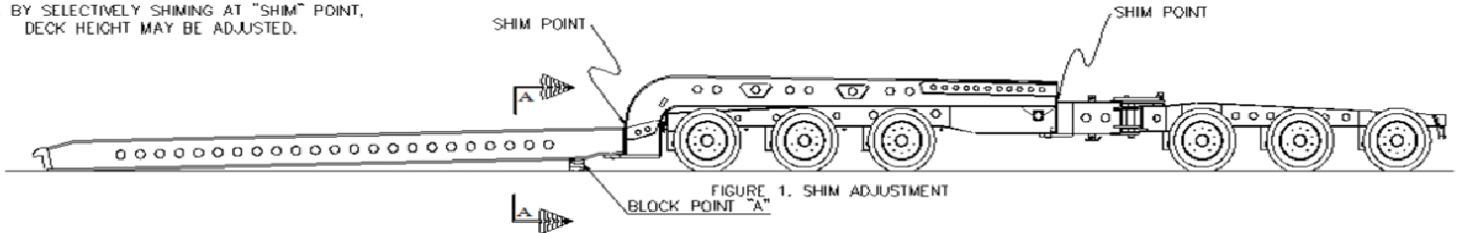

REAR BOGIE REMOVAL: (FIGURE 2)
1. BLOCK AT "B" REMOVE RETAINER BOLTS & DUMP AIR OFF REAR
THREE AXLES TO REMOVE

- DECK REMOVAL: (FIGURE 2)
- 1. BLOCK AT "A" AND LOWER FRONT OF DECK TO THE GROUND.
 - 2. REMOVE RETAINER BOLTS AT TOP REAR OF DECK TO BOGIE CONNECTION (SEE SECTION A-A)
 - 3. LET AIR SUSPENSION LOWER THE BOGIE AND THE BOGIE PIN PLATE
WILL DROP BELOW THE DECK PIN

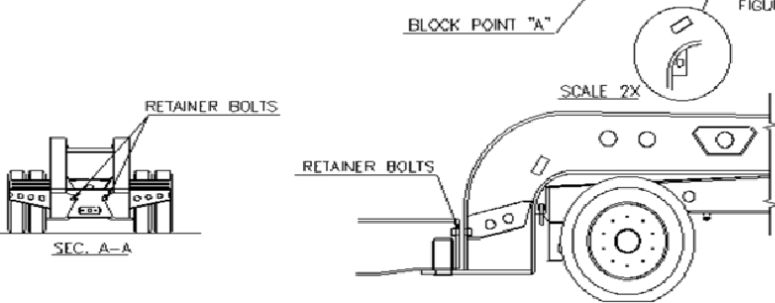
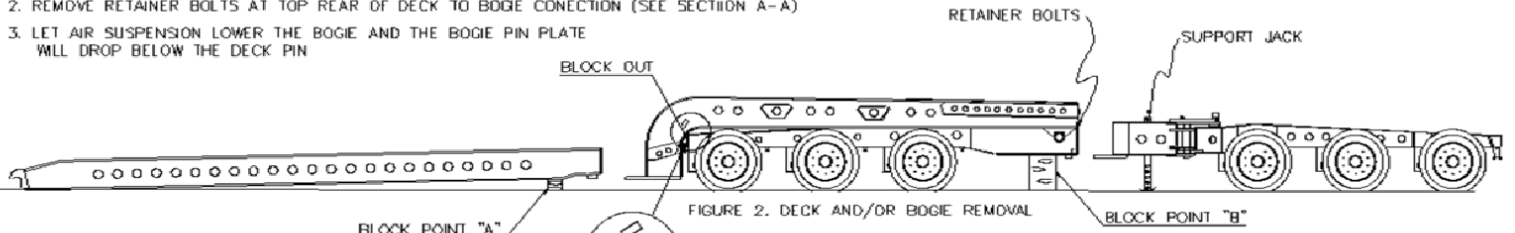

Operating Procedures

Rigid Spreader Versus Hydraulic Spreader

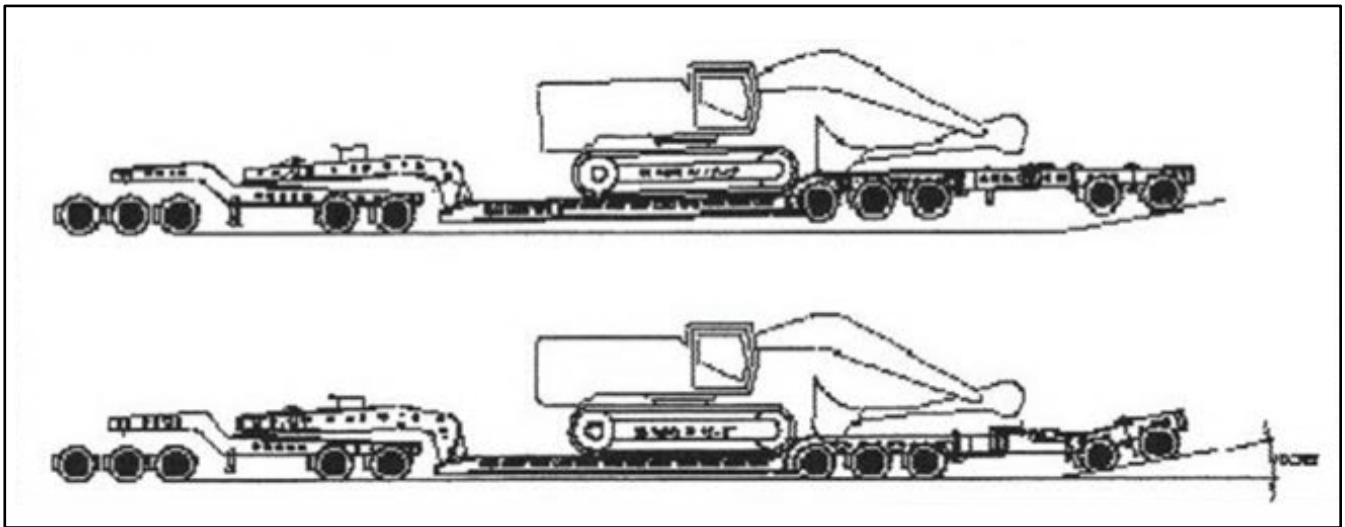

Notice how the hydraulic equalizer spreader helps with vertical curve issues.

Operating Procedures

Front Gooseneck Electrical/Glad Hands Hookups

The following are at the front of trailer gooseneck for hooking up to tractor.

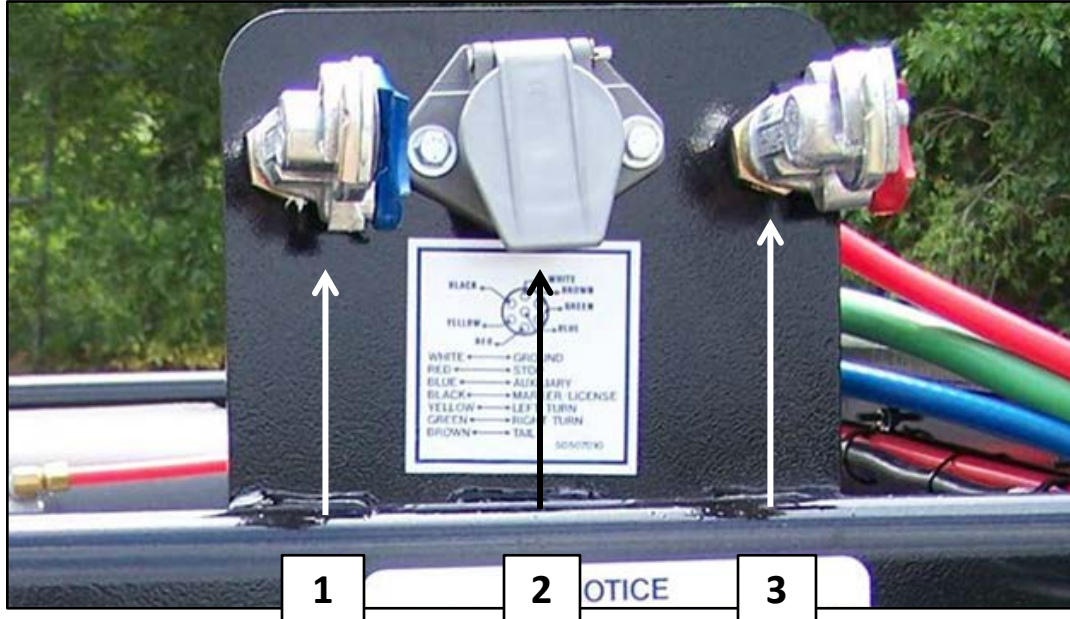

- 1. **BLUE GLAD HAND**—control air
- 2. **7-WAY ELECTRICAL PLUG**—for electrical harness
- 3. **RED GLAD HAND**—supply air

LED STROBE LIGHT CONTROL SWITCH

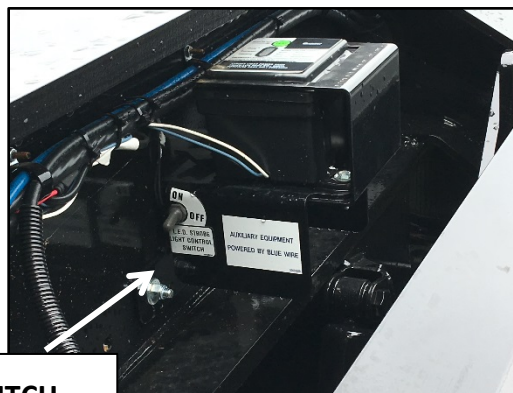

STROBE SWITCH

This switch is located on the left side (street side) on the trailer by the rear axle. Turn switch ON for the strobe light to illuminate.

Operating Procedures

Rear of Trailer Electrical/Air Coupler Hook Ups

The following are at the rear of trailer for hooking up a pin-on axle.

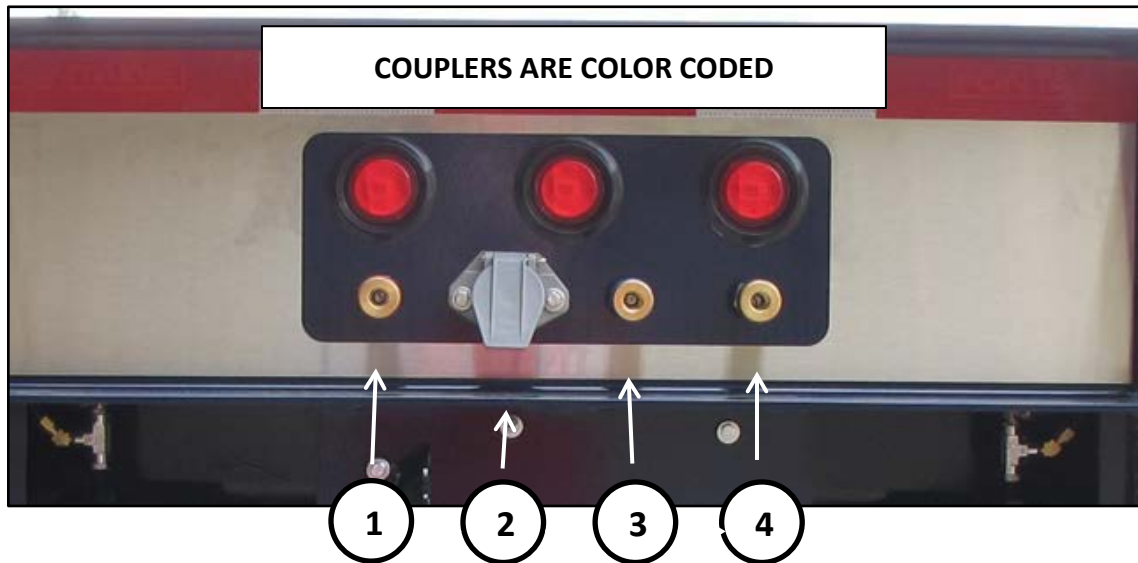

1. **RED QUICK COUPLER**—supply air
2. **7-WAY ELECTRICAL PLUG**—for electrical harness
3. **BLUE QUICK COUPLER**—control air
4. **BLACK QUICK COUPLER**—suspension air

Operating Procedures

Suspension Ride Height Adjustment

The following pages are a sequence for the ride height adjustment.

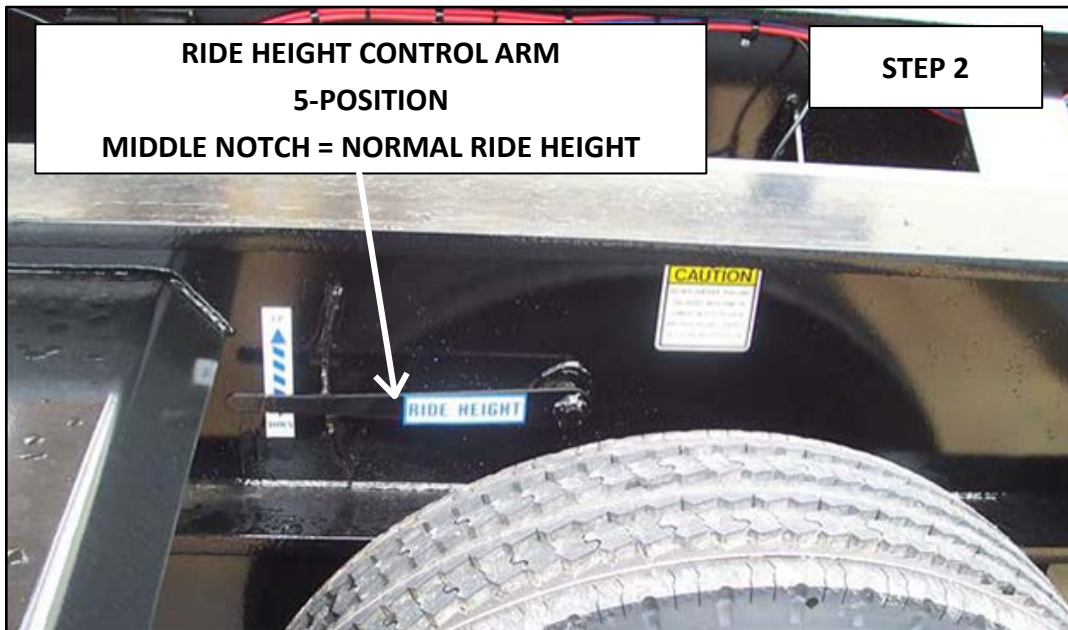
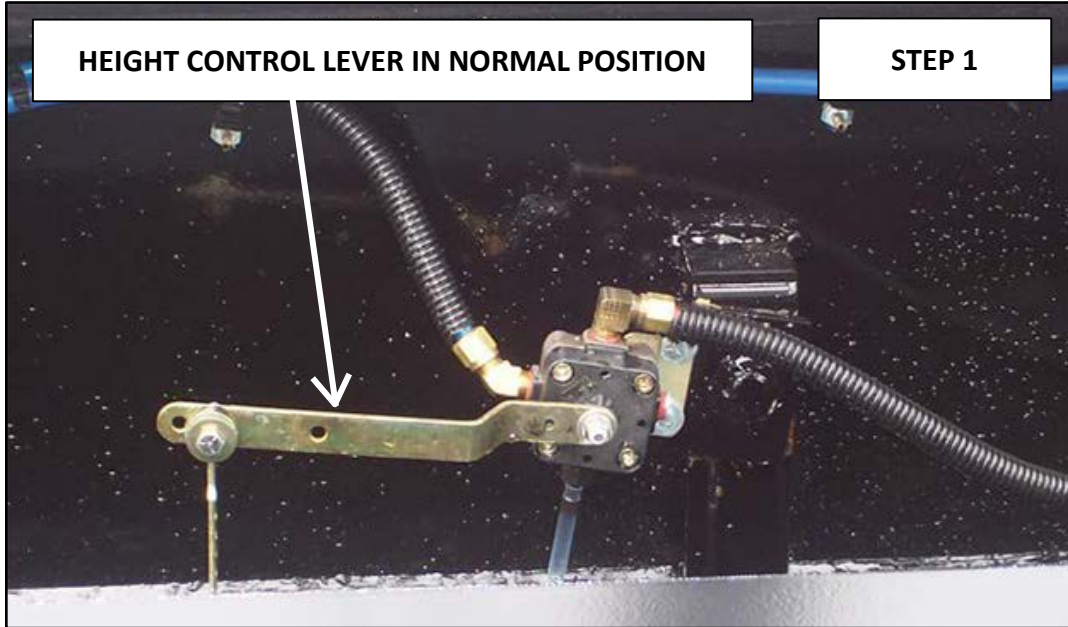

Operating Procedures

Suspension Ride Height Adjustment, *continued*

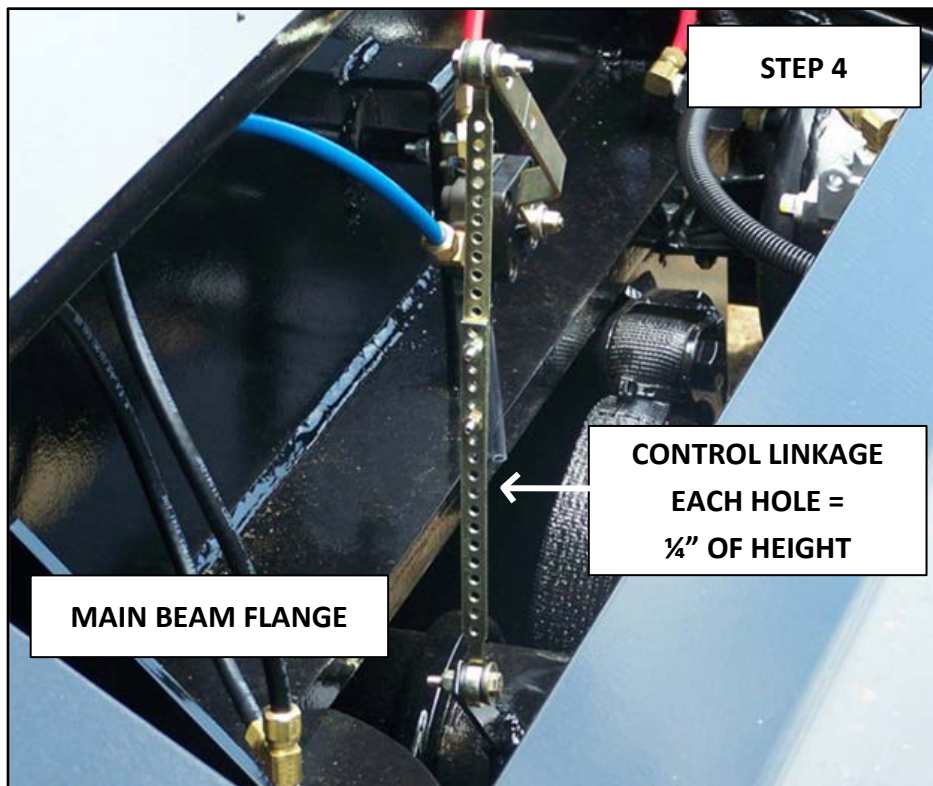
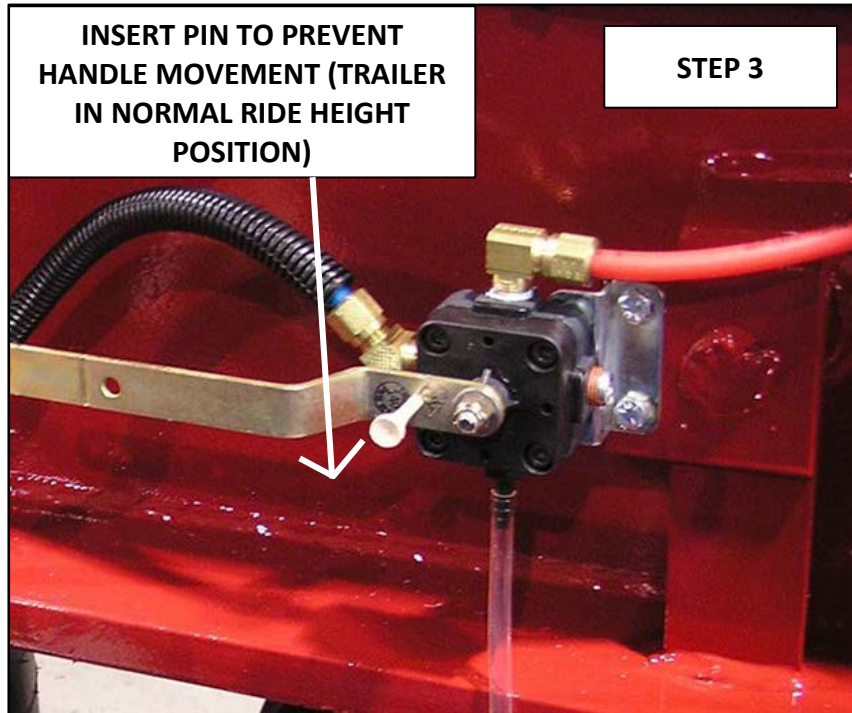

Operating Procedures

Suspension Ride Height Adjustment, *continued*

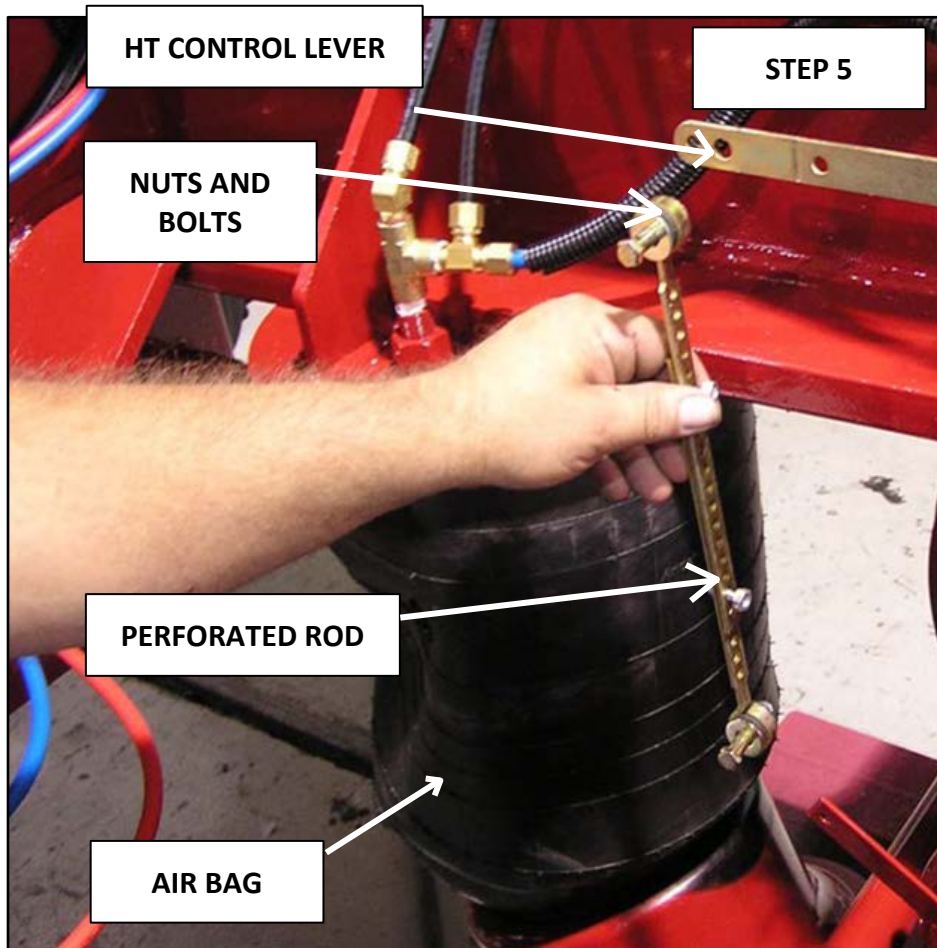

With pin in height control lever:

1. Remove nuts and bolts.
2. Measure distance from bottom of main beam flange to top of 1st or 2nd axle –see STEP 6.
3. Grab lower perforated rod and move until desired distance is reached, see STEP 6.
4. Reinstall nuts and bolts and secure.
5. Remove pin from height control lever.
6. Dump air from air bags.
7. Apply air to air bags and verify dimension (Y).

Operating Procedures

IGUS – Installation

Follow the steps below to install the IGUS® cable and hose carrier system on a Renegade LXT series or a Magnitude 55MX series trailer.

1. Follow the IGUS manufacturer's instructions to install the system onto the trailer.

Below is a view of the installed IGUS on the driver's side of the trailer.



Below is a different view of the installed IGUS on the driver's side of the trailer.



Operating Procedures

IGUS – Installation, *continued*

2. Insert the cables as shown in the illustration below.

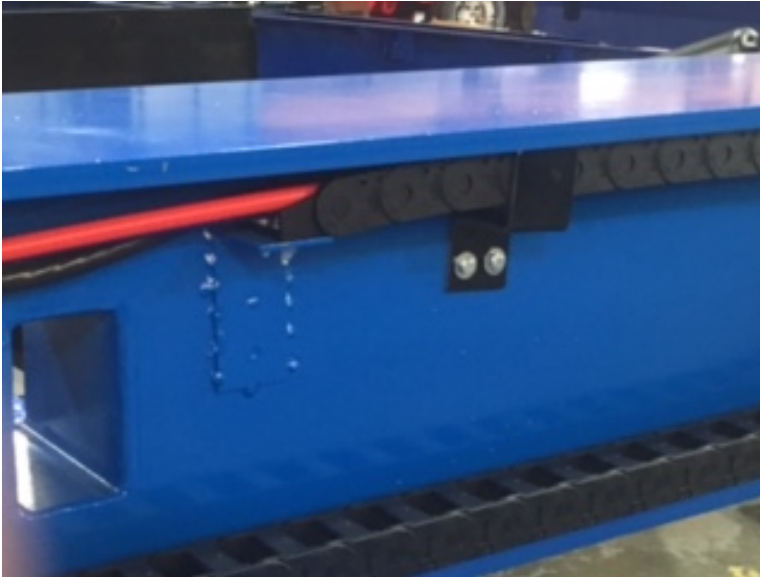

Operating Procedures

Roller and Shaft – Installation

Install the roller and shaft as shown in the illustration below:

1. Pull the trailer completely apart to allow access to the roller and shaft. An LXT and MX roller and shaft are shown below.



2. An XTP roller is shown below.



Operating Procedures

Power Unit (13HP) Installation, *continued*

3. Remove hardware and bumper stops from the plastic bag.



4. Place bumper stops in the slots shown in Step 2. Set the power unit on top of those stops as shown and tighten.

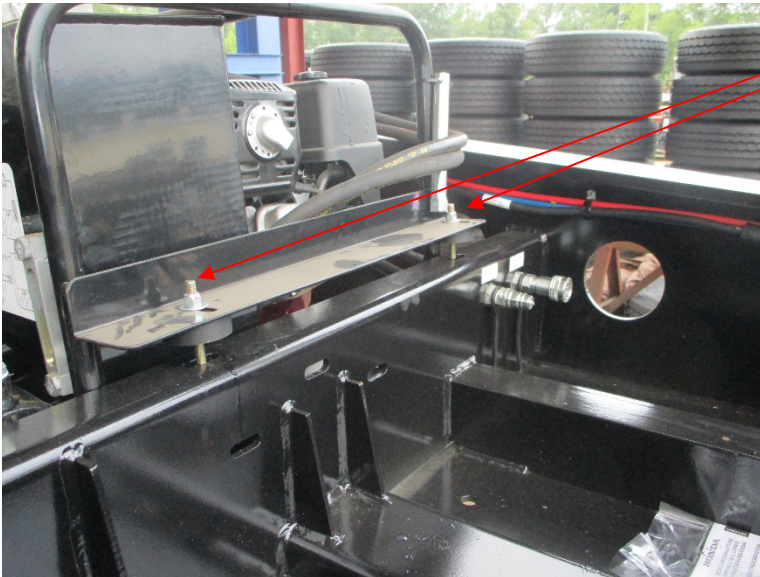

Operating Procedures

Power Unit (13HP) Installation, *continued*

5. Place the other side of the power unit on the frame jack arm.



6. Use the U-bolts with the protective sleeves as shown, and tighten.



Operating Procedures

Power Unit (13HP) Installation, *continued*

7. Connect the male/female, inlet/outlet hydraulic lines.

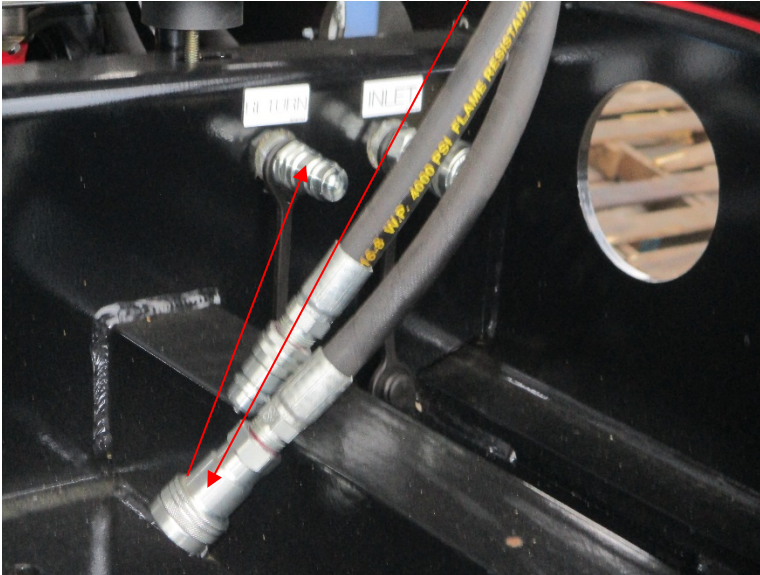

8. Add AW 30 hydraulic oil to the power unit until the tank shows 1/2 full in the site gauge.

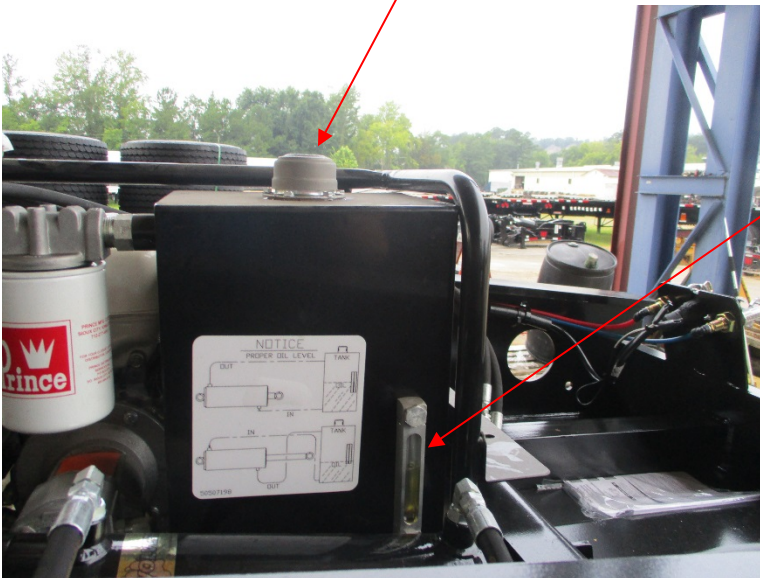

Operating Procedures

Hydraulic Requirement

Wet-Line Hydraulic Requirements for Operation of Hydraulically Removable Gooseneck Trailers

Your Fontaine trailer requires a two-line, pressure-and-return-line hydraulic system with a truck mounted reservoir. This reservoir should have a capacity equal to at least two times the pump output rating (see Note below). Truck pump output must be 6 gallons minimum to 10 gallons maximum while delivering 2500 psi hydraulic pressure. Hydraulic line quick disconnect fittings are furnished at the front of the trailer. Fontaine hydraulic systems are filled with #68 hydraulic oil. For cold weather operations, you may want to consider a lower weight oil such as #46 or #32 for even colder duty. Pony Motors come with AW#46.

Note: If hooking up a wet-line system to your truck, you will need to size the reservoir to at least 2 times the truck output. For example, the reservoir should be 12 gallons for a 6-gpm system.

Mating couplings are available through Fontaine Partsource, 1-866-382-7278.

Part numbers are listed below:

For (2 or 3) 7" or 8" Bore Cylinders:

1/2"	Female Coupler	FSI# 57325070	PCI# NV12F
1/2"	Male Coupler	FSI# 57325077	PCI# NV12M

Section 3: Maintenance Schedule

Maintenance Schedule

Frequent inspection and preventative maintenance are important in the life of any machine. Your Fontaine trailer is no exception. Proper care and maintenance will protect the long life of your trailer and may eliminate unnecessary repair costs and downtime.

Daily Intervals

Drain Moisture:

Drain the moisture from air reservoir daily by opening the drain cock on underside of reservoir. Leave the drain cock open until the moisture disappears. If vacuum brakes are used, open the moisture trap that is attached to bottom of relay valve. After all moisture has escaped, close the drain cock or moisture trap.

Inflate Tires:

Check tire pressure daily or every 3000 miles. Remove all objects lodged between treads or carcasses or from between duals.

Tighten Mounting Nuts:

See that all wheel and hub mounting nuts are present and secure.

Check Lights:

Open and close trailer light switches to see if lamps respond properly. Clean all lights and warning reflectors.

Check Tools and Equipment:

Check the tools, flares and other equipment to make certain all are present and in good condition. This inspection should become a daily habit. Minor repairs or adjustments depend to a great extent upon the tools and equipment carried on the trailer.

Monthly Intervals

Adjust Brakes:

Check the travel of brake chamber push rod and adjust brakes if necessary. Push rod travel should be kept at a minimum of 1/2" without the brakes dragging.

Inspect Hose Assemblies and Gaskets:

Inspect all hose assemblies and coupling gaskets for abrasions, swelling, or other damages. Replace as necessary.

Check Brake Linings:

Check the brake lining thickness. Brake lining should be replaced if excessively worn.

Maintenance Schedule

Monthly Intervals, *continued*

Inspect Reservoir and Brake Lines:

Inspect reservoir for looseness or damage. Make certain all connections are tight, and that brake lines are properly supported so as not to chafe on other trailer parts.

Check Electrical System:

Inspect lights, wiring, and coupling sockets. Secure loose wires.

Tighten Assembly, Screws and Nuts:

Tighten all wheel hub mounting nuts, spring clips, and U-bolts.

Measure and check all tires:

Measure and check all tires for proper mating and unserviceable condition. Serviceable tires that indicate abnormal wear should be rotated to other wheel positions. Apparent mechanical defects should be corrected.

Check Axle Alignment:

Check the axle for proper alignment. This deficiency is the most probable cause of tire wear.

Inspect and Clean Under-Construction:

Clean out all objects lodged in the under-construction or between units and springs, and inspect for excessive spring sag, shifted or broken leaves, loose or damaged clips. Check the radius rod rubber bushings to make certain they are in good condition and free of oil or grease.

Six Month Interval

Check structure for cracks in welds or steel. Check for any other structural damage. Fontaine Specialized Inc. should be consulted for repair instructions.

Maintenance Schedule

Lubrication Notes

1. **Coupler and Kingpin:** Clean all sand, grit and other foreign matter from coupler base. With a hand paddle, coat the machined surface of coupler base pickup ramps and edge of coupler hook. Place a light film of grease on the side surface of kingpin.
2. **Cam Bearing:** Lubricate sparingly with grease gun. Excessive lubrication will force lubricant into internal brake parts causing faulty brakes.
3. **Wheel Bearing:** Turn axle nut counterclockwise about 1/6 turn or slightly more until wheel turns freely. Test for excessive end play. Stand in front of hub, rest one end of wheel wrench handle on ground under tire and lift up on tire. By working the wrench handle up and down while holding one hand against the outer tire at the top, excessive end play can be quickly detected. If bearings are adjusted correctly, shake in wheel will be just perceptible, and it will turn freely with no drag. Install cotter pin. For units with oil seals on axles, use mineral-based Hypoid Oil SAE 90 to SAE 140.
4. **Brake Shoes:** Place several drops of oil on inner and outer end of brake shoe where anchor pins pass through the shoe. Place bar between spider and brake shoe, and lift the cam end of shoe off cam. Lubricate with several drops of oil on brake shoe roller and revolve roller.
5. **Cam:** When wheels are removed, place a light film of grease on top and bottom surface of S cam.



CAUTION

DO NOT ALLOW GREASE TO COME IN CONTACT WITH BRAKE LINING.

Lubrication Intervals

At 1,000 miles:

1. All points requiring light oil.
2. Regular grease fittings.
3. Fifth wheel and landing gear.

At 5,000 miles:

1. Repack all wheel bearings.
2. Grease brake cams.

Check all hanger bolts, U-bolts and other adjustable points at 5,000 miles.

Note: On units with oil seals, change oil every 50,000 miles.

Maintenance Schedule

Leaf Type Springs Care and Maintenance

The leaf springs in a heavy-duty truck/trailer suspension are working, flexible components and the main load supporting members in the assembly. They cushion the vehicle and its load from various road shocks and provide the necessary stability to resist roll-over, brake and drive forces. A reasonable amount of care and maintenance is required to provide a satisfactory service life.

The spring stack must be tightly clamped to its spring seat and the axle to prevent any movement between the U-bolts. This area is a dead zone and all flexing must take place between the U-bolts and the dead ends of the springs. Therefore, it is important to check the spring U-bolts for proper tightness once or twice during the first few months of service, until such time as the spring leaves wear in with usage. Thereafter, they should be checked periodically as a matter of normal maintenance.

One or more broken spring leaves near or through the center bolt hole indicate a loose U-bolt condition that has permitted excessive flexing in the clamp area. Failure to keep the U-bolts tight can also cause sheared spring center bolts, broken U-bolts, or rounding of the axle spring seat.

A broken spring leaf adjustment to or outside the U-bolt clamp area indicates either there has been an overloaded condition or the spring assembly is nearing the end of its service life. Single and multi-leaf springs on trucks and trailers should be closely inspected at regular intervals for signs of such failure. Broken leaves in a multi-leaf pile should be replaced immediately to prevent overloading the remaining leaves. Better yet, the complete spring stack should be replaced. If just the broken leaf is replaced, other leaves in the stack will break in a short length of time.

Springs are a mortality item. Failures can be expected from normal fatigue after a responsible service life.

In suspensions using the vari-rate springs and frame brackets, the wear pads and main spring leaves should be checked periodically for excessive wear. Replacement wear pads are available for most suspensions, and it may be necessary to install them long before the main leaf requires replacement. Excessive wear at these load contact points eliminates the vari-rate effect resulting in a rough ride. If these load-bearing points are left unattended, wear can progress to the point where a complete frame hanger replacement will be necessary. In some instances, an occasional dab of grease at these points will greatly reduce the fretting and wearing away of the wear pads and main spring leaf.

Service Tips

To obtain maximum service life from a spring assembly, perform the following steps:

1. Before placing trailer in service, torque all U-bolts evenly to manufacturer's recommendation.
2. Retorque at 3,000 miles and every 3 months thereafter.
3. Broken spring leaves between the U-bolts indicate loose U-bolts. Replace broken leaves at the earliest opportunity and lubricate the U-bolt threads before tightening.

Maintenance Schedule

Leaf Type Springs Care and Maintenance, *continued*

4. Spring leaf failures outside a U-bolt area are an indication of:
 - a. Repeated overload.
 - b. Spring assembly has completed its normal life cycle. In either case, the entire spring assembly should be replaced.
5. On vari-rate spring suspensions, periodically apply lubricant between the spring assembly and hangers to obtain maximum service life.

Basic Trailer Maintenance

NOTE

The information provided in this section is intended to provide suggested basic maintenance procedures. Refer to the vendor component supplier's information for more detailed maintenance instructions.

Kingpin and Fifth Wheel Area

Inspect the kingpin for excessive wear, rough edges, looseness, broken or chipped out areas and cracks. Any kingpin showing such condition must be replaced at once. Do not, under any circumstances, weld the kingpin to compensate for wear. Once a kingpin has been heated, its physical characteristics are changed and its subsequent performance cannot be predicted. Contact Fontaine Trailer Company Customer Service for proper replacement services.

Check and inspect the fifth-wheel area for cracks or breaks and for secure attachment to the trailer. Any welding performed in this area is to be restricted to those welds specified by Fontaine and is to be performed in the manner prescribed by Fontaine.

NOTE

Fontaine recommends that only an authorized Fontaine dealer perform repairs in the kingpin area.

Rear Impact Guards

Your new Fontaine trailer has been designed and tested to meet the requirements of NHTSA article 571.223 and 571.224.

The rear bumper should be checked during regular maintenance for cracks, bonds and other problems. If repair is needed, please refer to T.M.C. Recommended Practice 732 (T).

Wheel and Rim Care

Standard wheels on your Fontaine trailer are aluminum or steel disc wheels. Wheel nuts are inspected and tightened to specifications at the factory and are checked again at predelivery. To maintain the correct torque on the wheels of a new trailer, the nut torque must be checked periodically. During normal highway operation of a new trailer, this check should be made at the first 100, 500, and 1,000 miles and every 5,000 miles thereafter. Severe service conditions may require more tightening. Loose wheel nuts may cause shimmy, uneven tire wear, and vibration. Elongated stud holes in the wheels may result from loose hub nuts. Wheel and hub nuts must be torqued to proper specifications to provide maximum service life.

How to Service and Install Wheel Bearings

Wheel-bearing life depends on three things: (1) Proper lubrication; (2) Cleanliness; and (3) Proper adjustment. Trailer axle bearings are normally provided with wheel oil seals which only require keeping the oil at the proper level. Whether installing new bearings or servicing a trailer in the shop, here are the steps to follow:

1. Remove the wheel hub and bearing cones.
2. Clean all the old grease from wheel hub, bearing cones, and hub cap with kerosene or diesel fuel oil (not gasoline and not in hot solution tank or with water-alkaline solutions). Use a stiff fiber brush, but not a steel or brass wire brush.
3. Dry the parts with a clean absorbent cloth or paper. Compressed air can be used to dry the bearing only if the air is filtered, since water in the air line can cause rusting. Also, clean and dry the hands and tools, since grease will not adhere to a surface wet with solvent.
4. If bearings will not be used soon, pack with wheel-bearing grease and wrap in clean wax paper. Do not lay clean bearings on floor or dirty workbench.

Inspect for Damage

While the bearing is clean and free of grease, inspect it for signs of wear or damage. Excessive wear caused by abrasive dirt is the most common cause of premature bearing failure. This can be recognized by a dull appearance to the rollers and raceways; they may feel rough or show pit marks or indentations. Flaking or spalling on the small end of the rollers on their corresponding cup and cone rolling surfaces is caused by improper loose adjustment. Spalling or excessive wear at the large end of the rollers indicates an overly tight adjustment.

Fractures or fine hairline cracks across the cup or cone may be caused by forcing a cone assembly on an oversize spindle, or forcing a cup into warped hub bore, or by a cocked cup or a cocked cone. Brinelling (a series of lines or indentations on the raceways spaced to a definite pattern) indicates a driving force has squeezed the bearing and damaged the rollers and raceways. This can be caused by improper mounting practices or by sudden excessive shock loads.

Corrosion or its pockmarks on the raceways and rollers, resulting from water getting into the lubricant, can be caused by a worn or damaged grease seal, or by handling the bearing with moist hands, or by an improper type of lubricant. Overheated bearings have a blue or brown-blue discoloration, and definitely indicate that the bearing metal has been damaged. This can be caused by dirt, lack of lubricant, excessive friction, or too tight an adjustment.

Be sure to check the bearing cone for wear and pits. After the bearing is clean, hold it up so that the bearing is between the eye and the light. Look between the rollers so that the raceway or outer surface of the cone can be seen. Holding the cage, rotate the cone to check for pits over its entire outer surface.

How to Service and Install Wheel Bearings

Inspect for Damage, *continued*

Replace bearings if any of these conditions exist. Also replace worn or damaged grease or oil seals. Always replace a seal if it has been removed from the axle. Be sure to grease the lip of the grease seal before sliding it on the axle. Check the condition of the hub and axle spindle, and remove any nicks or burrs which might prevent proper seating.

The bearing cup must fit tightly in hub. This must be a press fit. Use an arbor press to install the cup in the hub, checking to make sure that it is square and completely bottomed. If an arbor press is not available, use an old bearing cup as a driving tool and tap it lightly with a hammer. Never strike the narrow section of a cup directly with a hammer, since this can chip or crack the case-hardened surface.

Adjustment of Bearings

Assemble the bearings and hub on the axle spindle and install the thrust washer if used. Screw the wheel-bearing adjustment nut on while revolving the wheel. Be sure there is no brake shoe drag that will interfere with the bearing adjustment. Tighten the adjusting nut to 50 foot pounds of torque while rotating the wheel in both directions. This step is necessary to align the individual rollers. If a torque wrench is not available, full arm pressure on a 12-inch wrench will produce about 50 foot pounds.

Back the adjusting nut off to get the proper end play or looseness. For double nut axles (such as Timken, Shuler, Clark, Utility, or Spicer) back off the adjusting nut about 1/3 turn to 1/4 turn. Then install the lock ring and the jam nut while holding the adjustment. Tighten the jam nut to about 200 foot pounds of torque (full body weight on 12-inch bar). When using a torque wrench, the actual recommendations are between 100 and 150 foot pounds if the thread size is under 2-5/8 inches, and 150 to 200 foot pounds if the thread size is over 2-5/8 inches. Then bend the lock ring over both the adjusting and jam nuts to lock the two in place.

Hub Installation and Maintenance

Disc Wheel Mounting—6 and 10 Stud Hubs BALL SEAT Mounted Disc Wheels

Rims must be correctly assembled using the correct cap nuts, and must be correctly aligned to ensure maximum service life and maximum safety.

1. All parts must be clean, free of rust, dirt or paint.
2. Position the inner wheel over the studs, being careful not to damage the threads.
3. Install inner cap nuts and tighten to 50 Ft. Lbs. in the sequence shown:

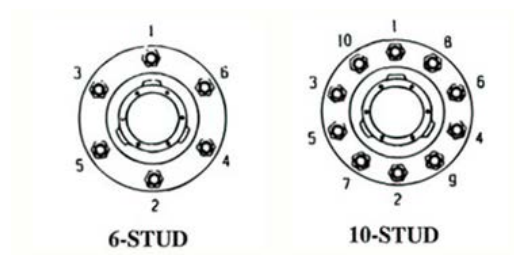

4. **Then** tighten to full torque using the same sequence.

Thread Size	Torque
Standard Cap nut	450–500 Ft. Lbs.
3/4-16 and 1-1/8-16	



CAUTION

The torque listed is for dry threads with no lubricant. Proper cap nut torque is important. Insufficient torque can cause stud breakage and damage. Over torque can over stress the studs and strip the threads.

5. Position the outer wheel over the inner cap nuts being careful not to damage the threads.
6. Install the outer cap nuts and tighten to 50 ft. lbs. in the sequence shown in Step 3. Then tighten to full torque using the same sequence.
7. After the first 50 to 100 miles of service the cap nut torque should be rechecked.
 - a. Loosen the outer cap nuts.
 - b. Check the torque of the inner cap nuts in the tightening direction.
 - c. Tighten the outer cap nuts to 50 ft. lbs. in the sequence shown if Step 5. Tighten to full torque using the same sequence.

Hub Installation and Maintenance

Disc Wheel Mounting—8 and 10 Stud Hubs HUB PILOTED Disc Wheels

1. All parts must be clean, free of rust, dirt or paint.
2. Position the inner wheel over the studs, being careful not to damage the threads.
3. Position the outer wheel over the studs, being careful not to damage the threads.
4. Install flange nuts and tighten to 50 Ft. Lbs. in the sequence shown:

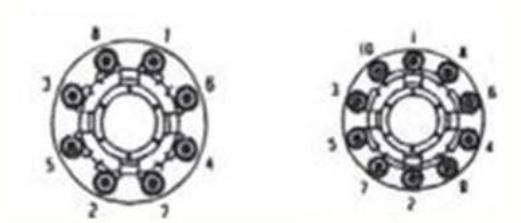

Then tighten to full torque using the same sequence

THREAD SIZE
Flange Nuts
M-22 x 1.5

Torque
 500–550 Ft. Lbs.



CAUTION

The torque listed is for dry threads with no lubricant. Proper cap nut torque is important. Insufficient torque can cause stud breakage and damage. Over torque can overstress the studs and strip the threads.

5. After the first 50 to 100 miles of service, the cap nut torque should be retightened to 500–550 ft. lbs.
6. Make sure the surface on the disc wheel that is contacted by the flange nuts is flat.
7. Disc wheel mounting surfaces should not have more than 1-1/2 mil thickness of paint. Excessive paint thickness can cause loose disc wheels.



CAUTION

Before installing two-piece cone lock cap nuts, lubricate the contact surfaces between the cap nut and washer with SAE 30W oil. This will minimize corrosion between the mating surfaces. Wheel studs on both hubs of vehicles that use the hub-piloted wheel system have right-hand threads.

Self-Adjusting Slack Adjuster

Operational Check

Functional operation of the slack adjuster can be performed on the vehicle as follows:

1. Block wheels to prevent vehicle from rolling.
2. Check that the push rod is fully retracted and apply air to release spring brake.
3. Manually de-adjust brakes (turn adjustment hex counterclockwise) to create an excessive clearance condition. (A ratcheting sound will occur.)
4. Make a full-service brake application on release, allow sufficient time for brake to fully retract. During the brake release, observe rotation of the adjustment hex (attaching a wrench on the hex will make this rotation easier to see). This rotation indicates that an excessive clearance condition has been determined by the slack adjuster, and it is making an adjustment to compensate. On each subsequent brake release, the amount of adjustment and pushrod travel will be reduced until the desired clearance is achieved.
5. Refer to the slack adjuster manufacturer's literature for the proper pushrod stroke.



NOTE

Refer to the slack adjuster manufacturer's recommendations for complete details on maintenance, inspection and troubleshooting of this component.

Maintenance

During normal chassis lube, adjusters should be inspected for damage. Check anchor brackets to ensure that they are tight.

During reline, check the de-adjustment torque. Place a torque wrench on the 7/16" adjusting hex. Turn the torque wrench counterclockwise and check that the clutch does not slip at a torque less than 13 Ft. Lbs. A ratcheting sound will occur while backing off. If clutch slips at a lesser torque, the adjuster must be replaced.

Lubrication

The self-adjusting slack adjuster should be lubricated in conjunction with the lubrication prescribed for the vehicle chassis. The lubrication interval should not, however, exceed 5,000 miles or 3 months. No special grease is required, however the use of molybdenum disulfide loaded grease or oil is not recommended since it may lower friction capabilities in the adjusting clutch parts and decrease automatic adjustment reliability.

Self-Adjusting Slack Adjuster

Inspection

1. During normal lubrication intervals, visually inspect slack adjuster and anchor bracket for damage. Check that anchor bracket is tight and the control arm is in its "Full Release" position (refer to manufacturer's literature).
2. Maintaining proper brake adjustment and brake balance cannot be accomplished by the slack adjuster alone. The condition of foundation brake components has a direct bearing on the effectiveness of brake adjustment. As a result, periodic inspection of these components is necessary.
 - Brake Chambers

Check that brake chamber mounting bolts are tight and proper alignment is maintained to avoid interference between chamber pushrod and chamber housing. Verify that the brake chamber pushrod length is equal on opposing brake chambers of the same axle.
 - Camshaft Bushings

Optimum brake adjustment cannot be achieved when worn bushings are used.
 - Wheel-Bearing Adjustment

Accurate wheel-bearing preload is necessary to maintain proper alignment between the brake drum and brake shoes.

Maintenance Schedule

Tips for Prolonged Brake Drum Life

1. Allow periodic cooling off stops when operating in mountainous terrain, but do not set brakes when drums are extremely hot. Park on level ground, in gear, for cooling-down period.
2. If possible, avoid water pockets in road that may drench red-hot drums and cause cracking.
3. Do not favor tractor or trailer brakes at the expense of each other. This reduces braking action of the unit and places a severe burden on the brake components doing the work.
4. Periodically inspect valves, linings, drums, cams and other brake parts to see that they are properly adjusted and in good working order.
5. Replace bent or distorted brake shoes immediately.
6. Replace worn brake linings before the bolts or rivets have a chance to score the drums.
7. Remove small stones or foreign matter that may occasionally get inside drums.
8. Consult reputable brake lining specialists for recommended makes and grades of lining that will prolong drum life.
9. Make sure tractor-trailer units have an adequate ratio of surface lining area to gross vehicle weight.
10. Do not overload.
11. Balance loads whenever possible to maintain uniform axle-load and therefore brake-drum distribution.
12. Use brake drums of adequate weight and thickness for unusual or severe applications.
13. Practice safe, sensible driving habits.

Tire Maintenance

Inflation Pressure

The most critical factor in tire maintenance is proper inflation. No tire or tube is completely impervious to loss of air pressure. To avoid the hazards of under inflation, lost air must be replaced.

Driving on any tire that does not have the correct inflation pressure is dangerous and will cause tire damage.

Any underinflated tire builds up excessive heat that may result in sudden tire destruction. The correct inflation pressures for your tires are a function of many factors, including load, speed, road surface and handling. Consult your tire dealer for the proper inflation pressures for your application.

Check inflation pressures on all your tires at least once a week, including spares, before driving. Check pressure when tires are cold, especially when more than one driver uses the vehicle.



CAUTION

Failure to maintain correct inflation pressure may result in sudden tire destruction, improper vehicle handling, and may cause rapid and irregular tire wear. Therefore, inflation pressures should be checked weekly and always before long-distance trips.

Pressure should be checked when tires are cold, before they have been driven over the road. The ideal time to check tire pressures is early morning. Driving, even for a short distance, causes tires to heat up and air pressures to increase.

Never bleed air from hot tires, as your tires will then be underinflated. Make sure to check both tires in a dual fitment. Pressures should be the same.

For optimum tire performance, it is usually best to use the tire inflation pressure recommended by the tire manufacturer for the particular axle load. Exceeding this pressure could result in reduced traction and tread life.

Tire Inspection

While checking inflation pressures, it is a good time to inspect your tires. ANY TIME YOU SEE ANY DAMAGE TO YOUR TIRES OR WHEELS/RIMS, SEE ANY OF YOUR TIRE DEALERS AT ONCE.

Before driving, inspect your tires, including the spare, and check your air pressures. If your pressure check indicates that one of your tires has lost pressure of four pounds or more, look for signs of penetrations, valve leakage or wheel/rim damage that may account for air loss.

Always examine your tires for bulges, cracks, cuts or penetrations. If any such damage is found, a tire dealer must inspect the tire at once. Use of a damaged tire could result in tire destruction, property damage and personal injury.

Tire Maintenance

Drive Carefully

All tires will wear out faster when subjected to high speeds as well as hard cornering, rapid starts, sudden stops and frequent driving on surfaces that are in poor condition. Surfaces with potholes or rocks and other objects can damage tires and cause vehicle misalignment. When you drive on such surfaces, drive on them carefully and slowly. Before driving at normal or highway speeds, examine your tires for any damage, such as cuts or penetrations.

Do Not Overload

The maximum load that can be put on a truck tire depends on the speed at which the tire will be used. Consult your tire dealer for complete information on the allowable loads for your tires and your application. Tires that are loaded beyond their maximum allowable loads for the particular application will build up excessive heat that may result in sudden tire destruction, property damage and personal injury.

Do not exceed the gross axle weight ratings for any axle on your vehicle.

Drive at Proper Speeds

The maximum speed at which tires can be operated is indicated in the tire manufacturer's data book. This speed varies for each type of tire and depends on the type of application. Consult your tire dealer for assistance in determining the maximum speed for your application. You should not exceed reasonable speeds indicated by the legal limits and driving conditions.



CAUTION

Exceeding the maximum speed that your tires are rated for can result in sudden tire destruction, property damage and personal injury.

WHEN DRIVING AT HIGHWAY SPEEDS, CORRECT INFLATION PRESSURE IS ESPECIALLY IMPORTANT.

However, at these speeds, even with correct inflation pressures, a road hazard, for example, is more difficult to avoid and, if contact is made, has a greater chance of causing tire damage than at lower speeds. Moreover, driving at high speed increases the possibility of an accident, as a greater distance is required to bring your vehicle to a safe stop.

Tire Maintenance

Balancing

Under normal conditions, truck tires do not need to be balanced. Common practice is to check tire balance if a ride complaint is made by the driver. Before removing the tire-wheel assembly from the vehicle, check for radial and lateral runout. Bent wheels and rims or improper mounting can cause excessive runouts. If balance is still required, a simple static balance with bubble balance or a wall mounted axle bearing and hub type gravity balance should be sufficient.

Rotation

Tires should be rotated only when necessary. If the tires are wearing evenly, there is no need to rotate. If irregular wear becomes apparent or if the wear rate on the tires is perceptively different (from axle to axle), then the tires should be rotated in such a manner as to alleviate the conditions.

Storage

All tires should be stored in a cool dry place indoors so that there is no danger of water collecting inside them. Serious problems can occur with tube-type tires when they are mounted with water trapped between the tire and tube. Due to pressurization, the liquid can pass through the inner liner and into the casing plies, resulting in sudden tire failure.

Most of the problems of this nature have been due to improper storage that allowed water to enter the casing. This is a particular problem with tube-type tires because of the difficulty in detecting water that has collected between the tire and tube. When tires are stored, they should be stored in a cool place away from sources of heat and ozone, such as hot pipes and electric generators. Be sure tires do not contact surfaces that could deteriorate the rubber. **TIRES EXPOSED TO THESE SUBSTANCES COULD BE SUBJECT TO SUDDEN FAILURE.**

Recommendations for the Use of Dynamometers

Severe damage can result in the crown area of radial truck tires when run on dynamometers for extended periods. Quite often the damage is internal and not discovered until after the vehicle has been put back in service.

Demounting and Mounting of Tube Type Tires

Tube Type Tires

1. Before unlocking a rim or ring, remove the valve core and allow the tire to deflate completely.
2. After demounting and disassembly, thoroughly inspect the rim or wheel.
3. Insert a new tube in the tire and inflate only until rounded out.
4. Lubricate tube and tire surface that will contact flap. (Do not over-lubricate and avoid allowing lubricant solution to run down into the tire.)
5. Lubricate the rim.
6. Fit center flap and lubricate all surfaces of the tire and flap that will contact the rim and flanges.
7. Place tire, tube and flap on wheel or rim, taking care to center valve in slot.
8. Fit side ring and lock rings and ensure that they are properly positioned and locked.

Primary Inflation

1. An air line with an extension (30" minimum) with an inline gauge and a clamp-on nozzle should be used for inflation. Remove valve core and lay the assembly flat on the ground. A portable guard should be employed. Inflate partially to seat beads, making sure all rim components are centered and locked properly. Check that the guide rib is concentric to the rim flange. If not, tire must be broken down, relubricated and reinflated.
2. Deflate tire by removing the air line. This allows the tube to relax, eliminating any wrinkles that may have occurred during primary inflation.

Final Inflation

1. Install valve core and, using a portable guard or safety cage, reinflate the tire to recommended pressure and install valve cap.
2. Reinspect assembly for proper positioning of all components.

Demounting

1. Deflate tire by removing valve core.
2. With the tire assembly lying flat, break the bead seat of both beads with a bead breaking tool.
3. Apply a proper tire lubricant to the tire beads, rim ledges and flanges.
4. Begin at the valve to ensure that the valve does not damage the bead. Make certain that the flange with the tapered ledge and the shortest span to the drop center is facing up. Remove the tire using irons designed for this purpose.

Always attempt to retain the areas of the bead not being worked by the irons in the full depth of the drop center cavity.

Demounting and Mounting of Tubeless Tires

Mounting

1. Clean and prepare rim.
2. Replace valve seals and inspect valve stem for damage or wear. Replace valve stem if necessary.
3. Lubricate tire beads and entire rim face.
4. With the short ledge up, lay the tire over the rim at the valve side and work it on with proper tubeless tire tools, making full use of the drop center cavity.

Tubeless Inflation

Stand tire/wheel assembly vertically using a portable guard, and inflate partially to seat the beads. If beads do not seat, keep air line inflated. Bounce the assembly lightly on the ground while turning it at the same time. When beads are seated, check that the guide rib is concentric to the rim flange. If not concentric, the tire should be broken down and repositioned.

When beads are properly seated, using a portable guard or safety cage, inflate tire to recommended pressure and install valve cap.

Additional Information

Always use a safety device when inflating. Never stand over tire or in front of valve when inflating. Before final inflation, check the assembly carefully for apparent sign of weakness or irregularities. Be careful when using irons, particularly when gripping firmly. Make sure hands and irons are free from oil or grease. Irons can slip and fly.

Do not use steel hammers.

Always wear safety goggles or face shields when hammering, buffing or grinding rims or tires.

From: Michelin Technical Division, Lake Success, New York

Tire Mixing



CAUTION

Improper tire mixing can be dangerous on vehicles with four or more wheel positions. Radial and non-radial tires should not be mixed in a dual fitment.

Electrical System

Lights and Wiring

The lighting system for your trailer is a heavy duty, 12-volt, 30-amp system. The 7-way receptacle is located on the front of the trailer near the glad hands. The jumper cable from the truck tractor plugs into the trailer's 7-way receptacle to complete the electrical circuit to the trailer. The receptacle is equipped with a hinge-type cover to protect it from exposure to dirt and water. The same light switches that control the lights on the truck tractor control trailer lights.

Proper maintenance of the lighting system requires periodic cleaning of lamps and reflectors to ensure maximum visibility of the tractor and trailer. Use a damp cloth to wipe the lenses. A dry cloth will cause the dirt to act as an abrasive and scratch the lenses. A daily cleaning can be worth the time invested, and it is a good safety practice. Maintenance of the lighting and wiring system consists of an occasional inspection to see that all wiring connections are tight. Make sure the lighting units are securely mounted, and the wiring is not pinched or damaged. Inspect lights, couplings and sockets for their serviceability, and replace as required.

NOTE

All Fontaine trailers manufactured after March 1, 1997 are wired to provide constant power to the trailer's anti-lock brake system (ABS) from the *CENTER PIN* of the main 7-way connector at the front of the trailer. If you need help determining how your particular trailer is wired, contact Fontaine Trailer Company at 1-800-821-6535.

Turn Signal and Hazard Flasher System

The turn-signal lever and hazard flasher are located in the truck tractor. To operate the turn signals, the ignition switch must be in the ON position. The hazard flasher system is operated independently of the ignition system in most cases. All turn signal lights can be made to flash simultaneously by pulling out the activating knob on the hazard flasher switch.

Two flasher units are used for the trailer. One unit is used in the turn signal circuit and the other for the hazard flasher system located in the truck tractor. The most common problems with the turn signals and hazard flasher system are defective flashers, burned-out bulbs, blown fuses, defective switches or faulty wiring.

Reflectors

Reflectors are located on the front, sides and rear sections of the trailer. They should be kept clean by wiping with a damp cloth. Replace any reflectors that are cracked or broken.

Electrical System

Stop, Tail, Turn, Marker, and Identification Lights

To remove lens and bulb with grommet mount installations, insert a screwdriver under the lens flange and pry lens out of the soft housing.

To remove lens with flange mount installation, remove screws or rivets. Disconnect from plug and wire assembly. To replace lens and bulb with grommet mount installation, reconnect the plug and wire assembly, tilt the lens slightly and push lens into soft housing. To replace the lens and bulb with flange mount installation, reconnect the plug and wire assembly, align mounting holes and reinsert screws.

License Lamp

To remove license bulb from the license lamp, remove the mounting screws and remove license lamp cover. Follow the same instructions used for the clearance, marker and identification lights above. Reinstall cover using the mounting screws.

Hydraulic Oil

Draining Oil Reservoir

The hydraulic oil should be changed once a year or sooner if it becomes contaminated. Drain the system by removing the reservoir drain plug. Catch all oil in a suitable container. Reinstall the plug and fill reservoir to required level with the proper type and grade of oil.

Oil Recommendations

1. Use standard SAE 5W or SAE 10W hydraulic oil.
2. Detergent oils are not recommended because the additives attack the cylinder packing.
3. Never use crankcase draining transmission oil, kerosene, fuel oil, water or any non-lubricating fluids.
4. Never thin oil with kerosene or fuel oil in winter operation. Both of these cause packing to swell, resulting in plungers sticking. Good low-viscosity hydraulic oils are available on the market.

Care of Wood Decking for Platform Trailers

Platform trailers that set idle for periods of time are exposed to the elements, where they may suffer weather damage. This damage results from excessive sunlight, temperature and moisture. The damage from sunlight and high temperatures may take the form of shrinkage to the top face of the decking, causing larger than normal spacing to appear between boards. This will often be accompanied by concave cupping of the decking, which is more pronounced in wider width pieces, and cracking or splitting of the decking, known as season checking. These cracks may cause other problems. The cracks fill with rainwater and absorption of water into the wood can lead to degradation as trapped water penetrates the interior portion of the boards.

Prevention of weather damage can be greatly minimized by applying a good water repellent wood preservative to all visible surfaces of the decking. The cost of labor to apply the treatment and the material is modest compared to the potential degradation from the weather elements. It takes less than one hour of labor and approximately four gallons of repellent using a hand roller or preferably, a handheld pump-up sprayer.

Various types of products used are Thompson's® Waterseal®, Behr® sealant, linseed oil and WOODguard®*, which contains a preservative agent that may produce better results. Any of these products will help increase decking life. Incorporate a maintenance program for coating the decking will benefit the end user, especially if the trailer has been setting idle for any length of time.

Applying UV-inhibitors and water repellents twice annually (spring and fall) creates the best results. A liberal coating when the trailer is new will begin the process of limiting the effects of the environment.

Remember, wood is a product of nature and will acclimate to its surrounding environment. Properly seasoned decking can change dimensions after installation. The right conditions and excessive swings in the environment (from winter to summer) will take their toll on decking. Platforms setting dead lined or idle are subject to a different environment than those in operation, even in the same locations.

(*WOODguard by ISK Biosciences, Memphis, TN (800-524-1093).

Hydraulic Equalizer Spreader

Maintenance

Lubrication Intervals:

First 500 miles:

1. All points requiring light oil
2. All grease fittings

1000 Mile intervals:

1. All points requiring light oil
2. All grease fittings

First 2 weeks: Check Accumulator Safety Valve capscrews. Tighten as needed.

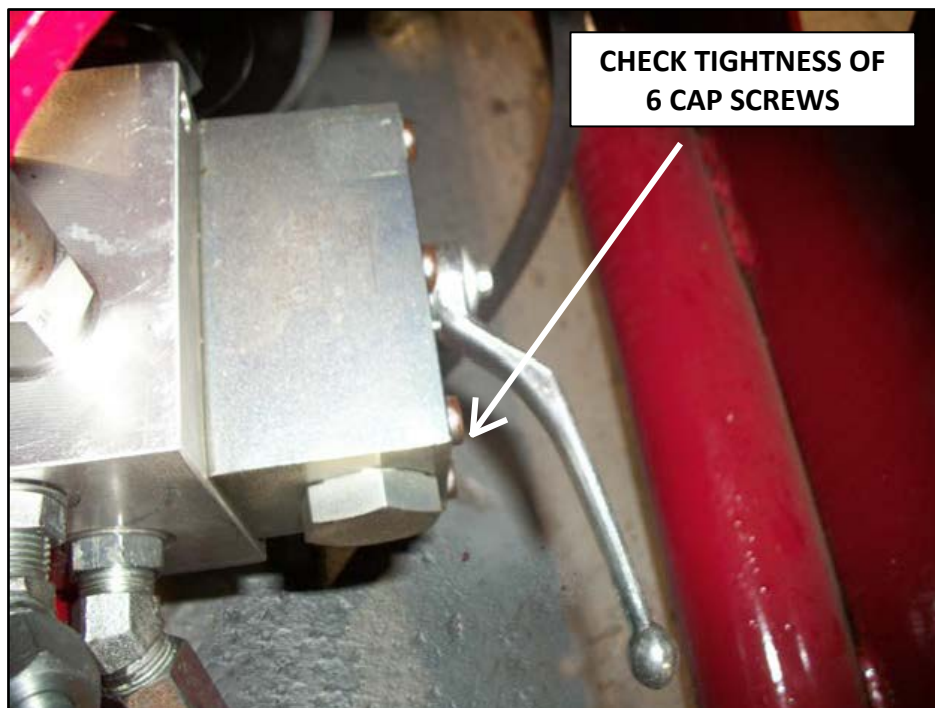

Hydraulic System Troubleshooting

Slow or No Hydraulic Lift Ability Under Load

1. Make sure the hydraulic fluid level is correct. Inspect the inlet suction strainer (from your truck PTO tank source).

NOTE

The Honda power unit tank has no strainer to check. Clean any blockage or debris if required.

2. Remove the hose from the back end of the cylinder and check flow rate. The flow should fill a 1-gallon container in 15 seconds.

If you **do not** get the recommended flow rate of 6.23 gpm at the Honda engine at full throttle (3600 rpm), go to Step 4. If the flow rate is normal, go to Step 3.

NOTE

If using a truck PTO, the recommended flow is 6–10 gpm at 2200–2400 psi.

3. Reconnect this line and plumb in a 0–3500 psi gauge. Apply flow and read the gauge.

If the pressure is 2200–2400 psi and the flow rate was right, you have a cylinder problem. Replace either the cylinder or repair the cylinder packing.

4. Remove the inlet hose from the directional valve. Record the flow rate from this as you did in Step 1.

If the flow rate is 6–10 gpm, go to Step 5. If the flow rate is less than 6–10 gpm, check the flow at the power source outlet point. If the flow output is low from the pump, replace the pump.

If the pump output is good, inspect the line from the pump to the valve for kinks or blockage; repair as required.

Hydraulic System Troubleshooting

Slow or No Hydraulic Lift Ability Under Load, *continued*

5. The problem is now isolated to the directional valve or check valve. Remove the check valve (see photo below) and inspect for blockage, damage, or stuck spring. Repair or replace this part if required.

If the problem still exists, you have leaking spool valves. Replace the directional valve.

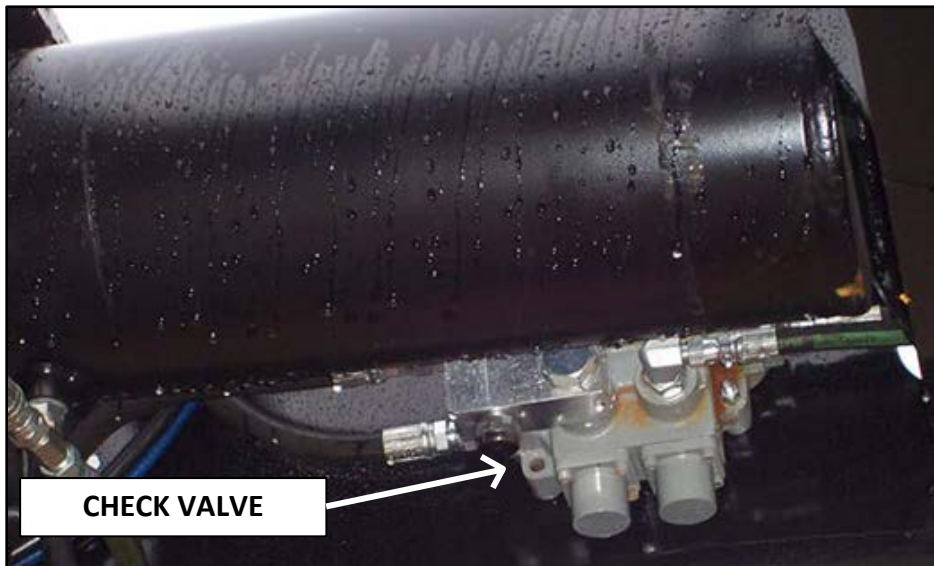

Troubleshooting—Analyzing and Diagnosing Trailer Service

To directly help keep your trailer on the road and rolling, the following troubleshooting guide has been prepared for your convenience. You can avoid serious delay and downtime in servicing your trailer if you can diagnose the cause of the trouble and correct it quickly.

Brakes

Brakes Will Not Release

Probable Cause

1. Low air pressure.
2. Brake shoes bound up at cams.
3. Brake out of adjustment.
4. Damaged brake assembly.

Remedy

1. Check air line connections and verify that there is sufficient air in tank.
2. Lubricate brake operating parts.
3. Adjust brakes.
4. See your nearest Fontaine Service Center.

No Brakes or Insufficient Brakes

Probable Cause

1. Source of air supply shut off at tractor.
2. Low brake line pressure.
3. Brake lines between tractor and trailer not properly coupled.
4. Reservoir drain cock open.

Remedy

1. Push control valve IN.
2. Check air pressure gauge on tractor—inoperative compressor.
3. Properly couple brake lines.
4. Close drain cock.

Slow Brake Application or Release

Probable Cause

1. Lack of lubrication.
2. Excessive travel in brake chamber.
3. Restriction in hose or line.
4. Defective brake valve.

Remedy

1. Lubricate brake operating parts.
2. Adjust brakes.
3. Replace broken hose or line.
4. Replace brake valve.

Troubleshooting—Analyzing and Diagnosing Trailer Service

Brakes, *continued*

Brakes Grabbing

Probable Cause

1. Foreign material on brake lining.
2. Brakes out of adjustment.
3. Brake drum out-of-round.
4. Damaged brake chamber or internal assembly.
5. Leaky or broken hose between relay valve and brake chamber.

Remedy

1. Reline brakes.
2. Adjust brakes.
3. Replace brake drum.
4. See your nearest Fontaine Service Center.
5. Replace or repair as required.

Brakes Dragging

Probable Cause

1. Out of adjustment.
2. Binding cam, anchor pins, or chamber rod end pin.
3. Damaged brake assembly or brake drum out-of-round.

Remedy

1. Adjust brakes.
2. Lubricate and free up.
3. Replace. See your nearest Fontaine Service Center.

Troubleshooting—Analyzing and Diagnosing Trailer Service

Wheels, Tires, and Alignment

Pulling Hard

Probable Cause

1. Broken or cracked spring.
2. Uneven load distribution.
3. Weak spring.
4. Axle out of alignment.
5. Tracking to one side or excess tire wear.

Remedy

1. Replace complete spring.
2. Rearrange load for proper distribution.
3. Replace complete spring.
4. Align axles.
5. Align axles.

WHEELS, HUBS, AND TIRES

Probable Cause

1. Tire wobble due to uneven rim clamping.
2. Burnt, worn, or damaged wheel bearings.
3. Bent wheel or rim.
4. Bent axle.

Remedy

1. Torque tighten all rim clamps.
2. Replace bearings.
3. Replace wheel or rim.
4. Replace or straighten axle.

Scuffed Tires

Probable Cause

1. Over and under inflation.
2. Excessive speed on turns.

Remedy

1. Inflate to proper pressure.
2. Reduce speed.

Troubleshooting—Analyzing and Diagnosing Trailer Service

Wheels, Tires, and Alignment, *continued*

Tracking to One Side

Probable Cause

1. Leaf spring broken.
2. Bent axle.
3. Axles out of alignment.

Remedy

1. Replace complete spring.
2. Replace or straighten axle.
3. Align axles.

Loss of Tire Air Pressure

Probable Cause

1. Puncture in tire.
2. Faulty valve or valve core.

Remedy

1. Repair or replace tire.
2. Replace valve assembly or core.

Uneven Tire Wear

Probable Cause

1. Over and under inflation.
2. Loose wheel stud nuts or clamps.
3. Loose or tight wheel-bearing adjustment.
4. Axle bent or out of alignment.
5. Tires not properly matched.
6. Improper brake actuation.
7. Rapid stopping.
8. High speed driving on turns.

Remedy

1. Inflate to proper pressure.
2. Tighten wheel stud nuts or clamps.
3. Adjust bearings.
4. Straighten, align, or replace axle.
5. Match tires.
6. Correct brakes as required.
7. Apply brakes slowly when approaching stop.
8. Reduce speed.

Troubleshooting—Analyzing and Diagnosing Trailer Service

Landing Gear

Difficulty Turning Hand Crank

Probable Cause

1. Bent crank shaft.
2. Bent cross shaft.
3. Lack of lubricant or correct lubricant.
4. Gears or components damaged.
5. Jackscrew nut jammed.

Remedy

1. Straighten or replace shaft.
2. Replace shaft.
3. Lubricate in accordance with lubrication chart.
6. Free up or replace.
7. Replace inner leg assembly.

Troubleshooting—Analyzing and Diagnosing Trailer Service

Electrical System

Wiring, Fuses and Circuit Breakers

Probable Cause

1. Circuit breaker kicks off.
2. Wires burned.
3. Contact points dirty or corroded.
4. Loss of ground at bulb.

Remedy

1. Correct short. Splice or repair wiring.
2. Replace wiring.
3. Remove lamp unit and clean.
4. Repair as necessary.

Complete Loss of Trailer Lights

Probable Cause

1. Broken main harness.
2. Blown fuse or breaker.
3. Broken ground lead between tractor and trailer.
4. Loose or corroded connection in ground lead between tractor and trailer.

Remedy

1. Repair or replace wire.
2. Replace fuse.
3. Check, repair, or replace jumper cable if equipped.
4. Repair or replace.

Dim or Flickering Lights

Probable Cause

1. Battery on tractor not sufficiently charged.
2. Damaged wire in jumper cable.
3. Dirty or corroded contact blades.
4. Loose connection.
5. Poor ground at socket.

Remedy

1. Change battery.
2. Repair or replace wire.
3. Clean contact blades.
4. Repair as necessary.
5. Repair as necessary.

Troubleshooting—Analyzing and Diagnosing Trailer Service

Hydraulic System

Cylinder Will Not Operate

Probable Cause

1. Insufficient oil level.
2. Restriction of oil flow.
3. Pump is worn.
4. Hydraulic hose not connected.
5. Restricted control linkage.
6. Broken key or keyway in drive.

Remedy

1. Fill reservoir to proper level.
2. Remove restriction.
3. Repair or replace pump.
4. Connect hose.
5. Check and repair linkage.
6. Repair or replace key.

Cylinder Will Not Hold

Probable Cause

1. Air in hydraulic system.
2. Valve control level not in hold position.
3. Worn control valve.
4. Worn pump.

Remedy

1. Bleed system by making several cycles.
2. Check and repair linkage.
3. Replace or repair valve.
4. Replace or repair pump.

Noisy Pump

Probable Cause

1. Air in hydraulic system.
2. Restriction of oil flow.
3. Insufficient oil supply.
4. PTO running at excessive RPM.
5. Water in oil.
6. Dirty or contaminated oil.
7. Use of wrong viscosity or type oil.
8. Worn or damaged pump.

Remedy

1. Bleed system by making several cycles.
2. Remove restriction.
3. Fill reservoir.
4. Lower PTO RPMs.
5. Drain system and replace oil.
6. Drain system and replace oil.
7. Drain. Replace with recommended oil.
8. Replace pump.

Reporting Safety Defects

If you believe that your vehicle has a defect that could cause a crash or could cause injury or death, you should immediately inform the **National Highway Traffic Safety Administration (NHTSA)**, in addition to notifying **Fontaine Trailer Company**.

If NHTSA receives similar complaints, it may open an investigation, and if it finds that a safety defect exists in a group of vehicles, it may order a recall and remedy campaign. However, NHTSA cannot become involved in any individual problems between you, your dealer or Fontaine Trailer Company.

To contact NHTSA you can either call the Auto Safety Hotline toll-free at 1-800-424-9393 (800-366-0123 in Washington DC area) or write NHTSA at the following address:

NHTSA
U.S. Department of Transportation
400 7th Street SW, (NSA-11)
Washington, DC 20590

You can also obtain other information about motor vehicle safety from the NHTSA Hotline.

You can contact Fontaine Trailer Company at the following address:

Fontaine Trailer Company
5398 US Highway 11
Springville, AL 35146
1-800-633-6551
www.fontaineheavyhaul.com

Section 4: Fontaine Parts and Service

Parts and Service



**ALWAYS
INSIST ON
FONTAINE
PARTS AND
SERVICE**

**Call 205-485-1310
Fontaine Partsource**

This page left intentionally blank for pagination purposes.

Index

A

ABS Notice - Connector Wiring Change	1-21
Accessing Deck (Xcalibur units).....	1-30
Anchor Points - Working Load Limits.....	1-31
Anti-Lock Braking System.....	1-22, 1-23
Axle Alignment.....	1-15, 3-2

B

Bulkhead Securement (Xcalibur Trailers)	1-35
---	------

C

Care of Wood Decking for Platform Trailers.....	3-22
Checking Trailer Ride Height (Xcalibur Trailers)	1-17, 1-18, 1-19
Coupling and Uncoupling.....	1-24

D

Decal Locations	1-4
Deck Extensions Operations	2-42
Demounting and Mounting of Tube Type Tires.....	3-17
Demounting and Mounting of Tubeless Tires	3-18

E

Electrical System	3-2, 3-19, 3-20, 3-31
-------------------------	-----------------------

F

Fontaine Parts and Service	4-1
Front Gooseneck Electrical/Gladhands Hookups	2-45

G

Gortrac – Installation	2-50, 2-51
------------------------------	------------

H

Hub Installation and Maintenance	3-9
--	-----

Hydraulic Equalizer System Troubleshooting	3-32
Hydraulic Oil Specifications.....	3-21

K

Kingpin and Fifth Wheel Area	3-6
------------------------------------	-----

L

Landing Gear	3-30
Leaf Type Springs Care and Maintenance	3-4, 3-5
LED Strobe Light Control Switch	2-45
Load Characteristics – Double Drop Extendables.....	2-41
Load Securements	
Anchor Points/Ratings	1-31
Bulkhead (Xcalibur Trailers).....	1-35
Lashing Rings	1-32
Winches	1-32
Lubrication Notes.....	3-3

M

Maintenance Records	3-34
Maintenance Schedule Daily/Monthly	3-1
Maintenance Schedule Six-Month.....	3-2
Modular Trailer Component Nomenclature.....	2-8

N

Nitrogen Pressure and Charging.....	2-34
Non-Ground-Bearing Operating Procedures	2-10

O

Operating Limits and Restrictions.....	1-3
--	-----

P

Power Unit (13HP) Installation	2-38
--------------------------------------	------

R

Rear of Trailer Electrical/Air Coupler Hook Ups	2-46
Removable Gooseneck Operation	2-40
Removable Gooseneck Trailers.....	2-56

Reporting Safety Defects	3-33
Rigid Spreader versus Hydraulic Spreader.....	2-44
Roller and Shaft – Installation.....	2-52

S

Shim Points and Applications.....	2-43
Slack Adjuster.....	3-11
Sliding Suspension (Xcalibur Trailers)	2-12
Suspension Ride Height Adjustment.....	2-47

T

Telescoping Deck Operating Procedures	2-11
Trailer Ride Height (Xcalibur Trailers).....	1-17
Troubleshooting	
Brakes	3-26
Electrical System.....	3-31
Hydraulic System	3-25, 3-32
Landing Gear.....	3-30
Wheels, Tires, Alignment.....	3-28

U

Uncoupling	1-24
------------------	------

Release Date: For Immediate Release

PUBLIC SERVICE ANNOUNCEMENT FROM FONTAINE®

**INDUSTRY SAFETY ALERT CONCERNING
CAB RACKS/CAB GUARDS**

HALEYVILLE, ALABAMA -- As part of our ongoing commitment to providing the best products and service in the industry, we wanted to alert you to an issue that has come to our attention.

While our focus, as our name implies, is the design and manufacture of world class flatbed trailers, we know that many of you, independent owner operators and fleets alike, have equipped your tractors with what were formerly known as “cab guards” and are today more commonly known as “cab racks” or “truck racks”. These optional aftermarket additions can serve as useful storage devices and may help to mitigate the effects of minor road debris, dirt and grime on the exterior of the cab.

WHETHER YOU CALL THEM “CAB GUARDS” OR “CAB RACKS” – THEY ARE NOT SAFETY DEVICES.

Cab racks are not designed, manufactured or installed as safety devices and are not intended to and will not prevent injury or death from load shifts or any other accident, collision or rollover scenario. Cab racks should never be used as a safety device or as a part of your load securement system. The presence of a cab rack is not a substitute for any component of a cargo securement system and does not alter the load securement requirements adopted by federal and state governments. Cab racks should never be used as a substitute for proper load securement when hauling a log or a pole trailer and should never be used unless all D.O.T. load securement regulations have been followed.

As the Federal Motor Carrier Safety Administration (FMCSA) has recognized, the most effective way to prevent the consequences of load shift is proper load securement (Development of a North American Standard for Protection Against Shifting and Falling Cargo, 67 FR 61212-01). We encourage all of you, whether you are new to the industry or a seasoned veteran, to review the load securement requirements developed by the FMCSA (49 CFR 393) and the requirements of the states in which you operate and to make every effort to adhere to these regulations for every load you haul.

Fontaine Commercial Platform, headquartered in Haleyville, Alabama, designs and manufactures world class aluminum, steel and composite flatbed and dropdeck trailers. Fontaine is a Marmon Highway Technologies/ Berkshire Hathaway company. Marmon Highway Technologies (MHT) supports the transportation industry worldwide with a wide range of high-quality products and services. For more information contact Fontaine Commercial Platform, 430 Letson Road • Haleyville, Alabama 35565 • 800-821-6535 • www.fontainetrailer.com.



Fontaine Commercial Platform • 430 Letson Road • Haleyville, Alabama 35565 • 800-821-6535 • www.fontainetrailer.com

 A Marmon Highway Technologies®/Berkshire Hathaway Company