



Liebert[®]

EXM UPS

User Manual

10kVA to 40kVA, 208/120V, 50/60Hz

The information contained in this document is subject to change without notice and may not be suitable for all applications. While every precaution has been taken to ensure the accuracy and completeness of this document, Vertiv™ assumes no responsibility and disclaims all liability for damages resulting from use of this information or for any errors or omissions. Refer to other local practices or building codes as applicable for the correct methods, tools, and materials to be used in performing procedures not specifically described in this document.

The products covered by this instruction manual are manufactured and/or sold by Vertiv™. This document is the property of Vertiv™ and contains confidential and proprietary information owned by Vertiv™. Any copying, use or disclosure of it without the written permission of Vertiv™ is strictly prohibited.

Names of companies and products are trademarks or registered trademarks of the respective companies. Any questions regarding usage of trademark names should be directed to the original manufacturer.

Technical Support Site

If you encounter any installation or operational issues with your product, check the pertinent section of this manual to see if the issue can be resolved by following outlined procedures.

Visit <https://www.Vertiv.com/en-us/support/> for additional assistance.

TABLE OF CONTENTS

IMPORTANT SAFETY INSTRUCTIONS	1
SAVE THESE INSTRUCTIONS	1
GLOSSARY OF SYMBOLS	7
1.0 INTRODUCTION	8
1.1 Operator Control and Display Panel	8
2.0 INSTALLATION	9
2.1 Initial Inspections	9
2.1.1 Storing the UPS and Batteries for Delayed Installation	9
2.2 Preliminary Checks	9
2.2.1 Identification	9
2.3 UPS Location	10
2.3.1 Positioning the UPS	10
2.3.2 Environmental Considerations	10
2.4 Battery Location	10
2.5 Considerations in Moving the Liebert EXM	10
2.6 Mechanical Considerations	11
2.6.1 Dimensions	12
2.6.2 Clearances	12
2.6.3 Floor Installation	13
2.6.4 Cable Entry	14
2.7 Auxiliary Cabinets	14
2.8 Power Module Assembly	16
2.9 Static Bypass Assembly	17
3.0 ELECTRICAL CONNECTIONS—UPS	18
3.1 Power Cabling	18
3.1.1 Lug Size and Cable Rating	18
3.2 External Protective Devices	19
3.2.1 Rectifier and Bypass Input Supply of the UPS	19
3.2.2 UPS Output	19
3.2.3 UPS Input Configuration	19
3.2.4 UPS Input Configuration with Transformers	22
3.2.5 Cabling Guidelines	23
3.2.6 Cable Connections	23
3.2.7 Accessory Fuses and Back-Feed Breaker Wiring	25
3.2.8 Safety Ground	27
3.2.9 Protective Devices	28
3.2.10 Cabling Procedure	29
3.3 Control Cables Details	30
3.3.1 Static Bypass Assembly Features	30

3.4	Dry Contacts	32
3.4.1	Input Dry Contacts.....	32
3.4.2	Output Dry Contacts.....	34
3.4.3	Liebert BDC Interface.....	35
3.4.4	Battery Cabinet Interface Connectors	35
3.4.5	EPO Input—Optional.....	36
3.5	Parallel Cable Connections	37
4.0	INSTALLATION DRAWINGS	38
5.0	OPTION INSTALLATION	41
5.1	Liebert IntelliSlot Communication	41
5.2	Liebert IntelliSlot Web Card—SNMP/HTTP Network Interface Card.....	41
5.2.1	Liebert IntelliSlot Unity Cards—IS-UNITY-LIFE, IS-UNITY-S, IS-UNITY-DP.....	41
5.3	Liebert IntelliSlot Web Card—Optional.....	42
5.4	Liebert IntelliSlot Relay Card	42
5.4.1	Liebert IntelliSlot Relay Card Pin Configuration	42
5.4.2	Liebert IntelliSlot Relay Card Jumper Setup.....	44
6.0	OPERATION.....	45
6.1	Touchscreen Control Panel.....	45
6.2	Access Level Log-In.....	46
6.3	Default PIN's.....	46
6.4	Liebert® EXM Operating Modes	46
6.5	UPS Startup	49
6.5.1	Startup Procedure	49
6.5.2	Startup in Eco Mode	49
6.5.3	Switching Between UPS Operation Modes	50
6.6	Switching the UPS from Normal Operation to Maintenance Bypass	50
6.7	Switching the UPS from Maintenance Bypass to Normal Operation	53
6.8	De-Energize Liebert® EXM with Maintenance Bypass Cabinet	55
6.9	De-Energize Liebert® EXM Without Maintenance Bypass Cabinet.....	55
6.10	Parallel Operations—Determine Control Panel Firmware Version.....	57
6.11	Parallel Operations—Software Version 1.1	57
6.11.1	De-Energize a Liebert® EXM Parallel System—Software Version 1.1	57
6.11.2	Re-Energize a Liebert® EXM Parallel System—Software Version 1.1.....	58
6.12	Emergency Shutdown With EPO.....	58
6.13	Auto Restart.....	58
6.14	Reset After Shutdown for Emergency Stop (EPO Action) or Other Conditions.....	59
6.15	Battery Protection	59
6.15.1	Battery Undervoltage Warning	59
6.15.2	Battery End-of-Discharge (EOD) Protection.....	59
6.16	Operation.....	60
6.17	Static Bypass Switch.....	60
7.0	SPECIFICATIONS AND TECHNICAL DATA.....	61
7.1	Conformity and Standards	61
7.1.1	ENERGY STAR® Certification	61

7.2	UPS Environmental	61
7.3	UPS Electrical Characteristics	62
8.0	MAINTENANCE	66
8.1	Safety Precautions	66
8.2	Battery Maintenance	68
8.3	Battery Safety Precautions	68
8.4	Limited-Life Components	70
8.5	Routine Maintenance	70
	8.5.1 Record Log	72
	8.5.2 Air Filters	72
	8.5.3 Torque Requirements	73
8.6	Detecting Trouble	74
8.7	Reporting a Problem	74
8.8	Corrective Actions	74
8.9	Recommended Test Equipment	74
APPENDIX A - HAZARDOUS SUBSTANCES OR ELEMENTS ANNOUNCEMENT		A75
APPENDIX B - UPS STATUS MESSAGES		A76

FIGURES

Figure 1	UPS dimensions	12
Figure 2	Clearances—Front, side and rear	13
Figure 3	Cable entry locations	14
Figure 4	Cabinet arrangement	15
Figure 5	Power Module Assembly indicators and controls	16
Figure 6	Static Bypass Assembly connections	17
Figure 7	Single UPS block diagram—Dual input, single source configuration, without bypass cabinet ...	20
Figure 8	Single UPS block diagram—Dual input, single source configuration	21
Figure 9	Liebert® EXM in a split bypass configuration	22
Figure 10	Input busbars—Liebert® EXM 10-40kVA frame	24
Figure 11	Accessory fuses	25
Figure 12	Dual input back-feed breaker wiring when bypass distribution cabinet not used	26
Figure 13	Ground and neutral busbar connections—10-40kVA frame busbars	28
Figure 14	Static bypass assembly connections to display cabinet and options	31
Figure 15	Auxiliary terminal block detail (static switch assembly front panel)	31
Figure 16	Input dry contacts	32
Figure 17	Output dry contacts and EPO wiring	34
Figure 18	Battery cabinet interface—J22	35
Figure 19	EPO wiring and signal names for J2	36
Figure 20	Single UPS Remote Emergency Power Off	37
Figure 21	Parallel cable wiring diagram	37
Figure 22	UPS dimensions	38
Figure 23	UPS main components—Typical 10-40kVA unit	39
Figure 24	UPS cable connections—10-40kVA frames	40
Figure 25	Liebert IntelliSlot Web card display	42

Figure 26	Pin location and numbering.....	43
Figure 27	Jumper location and numbering.....	44
Figure 28	One-line diagram, single-input UPS with 3-breaker maintenance bypass cabinet and panelboard.....	53
Figure 29	Typical configuration for single UPS.....	56
Figure 30	Air filter replacement.....	73

TABLES

Table 1	Weights for Liebert® EXM 10-40kVA frame.....	12
Table 2	LED indications on power module assembly.....	16
Table 3	Busbars (for power wiring).....	18
Table 4	Terminal block with compression lugs (for control wiring).....	18
Table 5	Input dry contacts—J26.....	33
Table 6	Output dry contact relays.....	34
Table 7	Battery cabinet interface—J22.....	35
Table 8	EPO input contact relays—J2.....	36
Table 9	Liebert® EXM communication options.....	41
Table 10	Relay card pin configuration.....	43
Table 11	Jumper connections.....	44
Table 12	UPS operating modes.....	60
Table 13	Environmental requirements.....	61
Table 14	UPS mechanical characteristics.....	61
Table 15	UPS currents and terminals—Input (for single-input unit, 208V operation).....	62
Table 16	UPS currents and terminals—Input (for dual-input unit only, 208V operation).....	62
Table 17	UPS currents and terminals—Bypass input (for dual-input units, 208V operation).....	62
Table 18	UPS currents and terminals—Output 208V.....	62
Table 19	AC/AC efficiency, loss and air exchange.....	63
Table 20	Rectifier input.....	63
Table 21	Recommended lug sizes (compression type) M10, 3/8" bolt.....	63
Table 22	Battery cabinet system—UPS and battery cabinet.....	63
Table 23	Battery DC intermediate circuit.....	64
Table 24	Inverter output to critical load.....	64
Table 25	Bypass input.....	65
Table 26	Component service life.....	70
Table 27	Busbars (for power wiring).....	73
Table 28	Terminal block with compression lugs (for control wiring).....	73
Table 29	Recommended test equipment and tools.....	74
Table 30	Hazardous substances or elements.....	75
Table 31	UPS status messages.....	76

IMPORTANT SAFETY INSTRUCTIONS

SAVE THESE INSTRUCTIONS

This manual contains important instructions that should be followed during installation of the Liebert® EXM. Read this manual thoroughly, paying special attention to the sections that apply to your installation, before working with the UPS. **Retain this manual for use by installing personnel.**

A properly trained and qualified electrical contractor should oversee the installation of the equipment.

The Liebert® EXM cannot be put into operation until it is commissioned by the manufacturer or authorized engineer. Otherwise, human safety may be endangered and damage to the UPS will not be covered by the warranty.

The Liebert® EXM is designed for commercial and industrial uses and cannot be used as life support equipment.



WARNING

Internal battery strapping must be verified prior to moving a battery cabinet (after initial installation).

- Battery cabinets contain non-spillable batteries.
- Keep units upright.
- Do not stack.
- Do not tilt.

Failure to heed this warning could result in smoke, fire or electric hazard.

Call 800-543-2378 prior to moving battery cabinets (after initial installation).



AVERTISSEMENT

L'arrimage des batteries internes doit être vérifié avant de déplacer une armoire de batteries (après l'installation initiale).

- Les armoires de batteries contiennent des batteries étanches.
- Maintenir les systèmes à la verticale.
- Ne pas empiler.
- Ne pas incliner.

Le non-respect de ces consignes comporte des risques liés à la fumée, au feu ou à l'électricité.

Composez le 1 800 LIEBERT avant de déplacer des armoires de batteries (après l'installation initiale).



WARNING

Risk of electrical shock and fire. Can cause equipment damage, personal injury or death.

Lead-acid batteries contain hazardous materials. Batteries must be handled, transported and recycled or discarded in accordance with federal, state and local regulations. Because lead is a toxic substance, lead-acid batteries must be recycled rather than discarded.

Do not dispose of battery or batteries in a fire. The battery may explode.

Do not open or mutilate the battery or batteries. Released electrolyte is harmful to the skin and eyes. It is toxic.

The following precautions must be observed when working on batteries:

- Remove watches, rings and other metal objects.
- Use tools with insulated handles.
- Wear rubber gloves and boots.
- Do not lay tools or metal parts on top of batteries.
- Disconnect charging source prior to connecting or disconnecting battery terminals.
- Determine whether the battery is grounded. If it is grounded, remove source of ground.

Contact with any part of a grounded battery can result in electrical shock. The likelihood of such shock will be reduced if such grounds are removed during installation and maintenance.



AVERTISSEMENT

Risque de décharge électrique et d'incendie. pouvant entraîner des dommages matériels, des blessures et même la mort.

Les batteries au plomb-acide renferment des matières dangereuses. Les batteries doivent être manipulées, transportées, recyclées ou jetées conformément aux règlements fédéraux, provinciaux et municipaux. Étant donné que le plomb est une substance toxique, les batteries au plomb-acide doivent être recyclées plutôt que mises au rebut.

Ne jetez jamais de batteries au feu car elles risquent d'exploser.

Vous ne devez ni ouvrir ni percer les batteries, car l'électrolyte qui s'en écoulerait est nocif pour la peau et les yeux. Cet électrolyte est toxique.

Lorsque vous travaillez avec des batteries, prenez les précautions suivantes :

- Retirez montre, bagues et tout autre objet métallique.
- Utilisez des outils dont le manche est isolé.
- Portez des gants et des bottes de caoutchouc.
- Ne posez aucun outil ni pièce métallique sur le dessus d'une batterie.
- Déconnectez la source de chargement avant de brancher ou de débrancher les bornes d'une batterie.
- Vérifiez si la batterie est mise à la terre. Le cas échéant, éliminez la cause de la mise à la terre.

Le contact avec toute partie d'une batterie mise à la terre peut provoquer une décharge électrique. Pour réduire de tels risques d'accident, débranchez les prises de terre avant de procéder à l'installation ou à l'entretien.



WARNING

Risk of electrical shock. Can cause personal injury or death.

This UPS has several circuits that are energized with high DC as well as AC voltages. Check for voltage with both AC and DC voltmeters before working within the UPS. Check for voltage with both AC and DC voltmeters before making contact.

Only properly trained and qualified personnel wearing appropriate safety headgear, gloves, shoes and glasses should be involved in installing the UPS or preparing the UPS for installation. When performing maintenance with any part of the equipment under power, service personnel and test equipment should be standing on rubber mats.

In case of fire involving electrical equipment, use only carbon dioxide fire extinguishers or those approved for use in fighting electrical fires.

Extreme caution is required when performing installation and maintenance.

Special safety precautions are required for procedures involving handling, installation and maintenance of the UPS system. Observe all safety precautions in this manual before handling or installing the UPS system. Observe all precautions before as well as during performance of all maintenance procedures.

Observe all DC safety precautions before working on or near the DC system.



AVERTISSEMENT

Risque de décharge électrique pouvant causer des blessures graves, voire mortelles.

Ce système ASC comporte plusieurs circuits à haute tension c.a et c.c. Vérifiez les tensions au moyen de voltmètres c.a. et c.c. avant d'utiliser le système ASC. Vérifiez les tensions avec des voltmètres c.a. et c.c. avant d'établir tout contact.

Seuls des employés qualifiés et dûment formés portant un casque, des gants, des chaussures et des lunettes de sécurité adéquats doivent se charger d'installer le système ASC ou de le préparer pour l'installation. Les responsables de l'entretien et l'équipement d'essai doivent reposer sur des tapis de caoutchouc lors de toute intervention sur une pièce d'équipement sous tension.

En cas d'incendie associé à du matériel électrique, n'utilisez que des extincteurs à dioxyde de carbone ou homologués pour la lutte contre les incendies d'origine électrique.

Les opérations d'installation et d'entretien requièrent une extrême prudence.

Des précautions de sécurité spéciales sont requises pour les procédures associées à la manutention, à l'installation et à l'entretien du système ASC. Observez toutes les précautions de sécurité décrites dans le présent manuel avant de manipuler ou d'installer le système ASC. Observez également toutes les précautions avant et pendant toutes les procédures d'entretien. Observez toutes les précautions de sécurité appropriées lorsque vous travaillez sur à proximité d'une source c.c. de sécurité appropriées dès que vous vous trouvez à proximité d'une source c.c.



WARNING

Risk of heavy unit falling over. Improper handling can cause equipment damage, injury or death.

Exercise extreme care when handling UPS cabinets to avoid equipment damage or injury to personnel.

The UPS module weight is up to 956 lb. (434kg).

Locate center of gravity symbols  and determine unit weight before handling each cabinet. Test lift and balance the cabinets before transporting. Maintain minimum tilt from vertical at all times.

Slots at the base of the module cabinets are intended for forklift use. Base slots will support the unit only if the forks are completely beneath the unit.

Read all of the following instructions before attempting to move, lift, or remove packaging from unit, or prepare unit for installation.



AVERTISSEMENT

Le centre de gravité élevé de l'appareil présente un risque de renversement. Une mauvaise manutention peut entraîner des dommages matériels, des blessures et même la mort.

Faites preuve d'une extrême prudence lors de la manutention des armoires ASC afin d'éviter de les endommager ou de blesser le personnel. Le module ASC pèse jusqu'à 434kg (956lb).

Identifiez les symboles de centre de gravité  et déterminez le poids de l'appareil avant de manipuler chaque armoire. Testez le levage et l'équilibre des armoires avant de transporter l'appareil. Maintenez en tout temps l'inclinaison verticale minimale.

Les fentes situées à la base des armoires du module sont conçues pour utiliser le chariot élévateur. Les fentes situées à la base peuvent soutenir le système seulement si les fourches se trouvent complètement sous le système.

Lisez toutes les instructions ci-dessous avant de tenter de déplacer, lever, débarrer ou préparer le système en vue de son installation.



WARNING

Risk of electrical shock and fire. Can cause equipment damage, personal injury or death.

Under typical operation and with all UPS doors closed, only normal safety precautions are necessary. The area around the UPS system should be kept free of puddles of water, excess moisture and debris.

Only test equipment designed for troubleshooting should be used. This is particularly true for oscilloscopes. Always check with an AC and DC voltmeter to ensure safety before making contact or using tools. Even when the power is turned Off, dangerously high potential electric charges may exist at the capacitor banks and at the DC connections.

All wiring must be installed by a properly trained and qualified electrician. All power and control wiring must comply with all applicable national, state and local codes.

One person should never work alone, even if all power is disconnected from the equipment. A second person should be standing by to assist and to summon help in case of an accident.



AVERTISSEMENT

Risque de décharge électrique et d'incendie, pouvant entraîner des dommages matériels, des blessures et même la mort.

Les précautions de sécurité habituelles suffisent lorsque le système ASC est en mode de fonctionnement normal et que toutes les portes sont fermées. La zone entourant le système ASC doit être exempte de flaques d'eau, d'humidité excessive et de débris.

Seuls des équipements d'essai conçus pour le dépannage doivent être utilisés. Cette mise en garde couvre notamment les oscilloscopes. Utilisez toujours un voltmètre c.a. et c.c. pour vérifier les tensions avant d'établir un contact ou d'utiliser des appareils. Des tensions dangereusement élevées peuvent demeurer dans les batteries de condensateurs et au niveau des raccords c.c., même une fois l'alimentation coupée.

Tous les raccords doivent être effectués par un électricien dûment formé et qualifié. Tous les câbles d'alimentation et de commande doivent être conformes aux codes nationaux et locaux en vigueur.

Une personne ne devrait jamais travailler seule, même si toute l'alimentation d'entrée est coupée. Une deuxième personne devrait toujours être présente pour porter assistance ou chercher de l'aide en cas d'accident.



NOTE

Materials sold hereunder cannot be used in the patient vicinity (e.g., use where UL, cUL or IEC 60601-1 is required). Medical applications such as invasive procedures and electrical life support equipment are subject to additional terms and conditions.

Ground Leakage Currents



WARNING

Risk of electric shock from high leakage current. Can cause injury, property damage and death.

EARTH CONNECTION IS ESSENTIAL BEFORE CONNECTING THE INPUT SUPPLY.

Earth leakage current exceeds 3.5 mA and is less than 1000 mA.

Transient and steady-state earth leakage currents, which may occur when starting the equipment, should be taken into account when selecting instantaneous RCCB or RCD devices.

Residual Current Circuit Breakers (RCCBs) must be selected sensitive to DC unidirectional pulses (Class A) and insensitive to transient current pulses.

Note also that the earth leakage currents of the load will be carried by this RCCB or RCD.

This equipment must be earthed in accordance with the local electrical code of practice.



AVERTISSEMENT

Risque de décharge électrique due à un courant de fuite élevé pouvant causer des blessures, des dommages matériels et même la mort.

IL EST PRIMORDIAL D'ASSURER UNE CONNEXION DE TERRE AVANT DE BRANCHER L'ALIMENTATION D'ENTRÉE. La fuite à la terre est supérieure à 3,5 mA et inférieure à 1 000 mA.

Vous devez tenir compte des fuites de courant transitoires et permanentes à la terre, susceptibles de se produire au démarrage de l'équipement, lors de la sélection des dispositifs DDFT instantanés.

Vous devez sélectionner des disjoncteurs différentiels de fuite à la terre (DDFT) sensibles aux impulsions unidirectionnelles c.c. (classe A) et insensibles aux impulsions de courant transitoires.

Notez également que les courants de fuite à la terre de la charge seront acheminés par ce dispositif DDFT.

Cet équipement doit être mis à la terre conformément au code national de l'électricité.



WARNING

Risk of electric shock. Can cause injury, property damage and death.

Under typical operation and with all UPS doors closed, only normal safety precautions are necessary. The area around the UPS system should be kept free of puddles of water, excess moisture and debris.

Special safety precautions are required for procedures involving handling, installation and maintenance of the UPS system. Observe all safety precautions in this manual before handling or installing the UPS system as well as during all maintenance procedures.

This equipment contains several circuits that are energized with high voltage. Only test equipment designed for troubleshooting should be used. This is particularly true for oscilloscopes. Always check with AC and DC voltmeters to ensure safety before making contact or using tools. Even when the power is turned Off, dangerously high electric charges may exist within the UPS.

All power and control wiring should be installed by a qualified electrician. All power and control wiring must comply with the NEC and applicable local codes.

ONLY qualified service personnel should perform maintenance on the UPS system. When performing maintenance with any part of the equipment under power, service personnel and test equipment should be standing on rubber mats. The service personnel should wear insulating shoes for isolation from direct contact with the floor (earth ground).

Never work alone, even if all power is removed from the equipment. A second person should be standing by to assist and summon help in case an accident should occur.



AVERTISSEMENT

Risque de décharge électrique pouvant causer des blessures, des dommages matériels et même la mort. Les précautions de sécurité habituelles suffisent lorsque le système ASC est en mode de fonctionnement normal et que toutes les portes sont fermées. La zone entourant le système ASC doit être exempte de flaques d'eau, d'humidité excessive et de débris.

Des précautions de sécurité spéciales sont requises pour les procédures associées à la manutention, à l'installation et à l'entretien du système ASC. Observez toutes les précautions de sécurité décrites dans le présent manuel avant de manipuler ou d'installer le système ASC, ainsi que pendant toutes les procédures d'entretien.

Cet équipement comporte plusieurs circuits à haute tension. Seuls des équipements d'essai conçus pour le dépannage doivent être utilisés. Cette mise en garde couvre notamment les oscilloscopes. Utilisez toujours des voltmètres c.a. et c.c. pour vérifier les tensions avant d'établir un contact ou d'utiliser des outils. Des tensions dangereusement élevées peuvent demeurer dans le système ASC même une fois l'alimentation coupée.

Tous les câbles d'alimentation et de contrôle doivent être installés par un électricien qualifié. Tous les câbles d'alimentation et de contrôle doivent être conformes au Code national de l'électricité des États-Unis (NEC) et celui du Canada, ainsi qu'aux codes locaux en vigueur.

L'entretien du système ASC ne doit être confié qu'à des professionnels qualifiés.

Les responsables de l'entretien et l'équipement d'essai doivent reposer sur des tapis de caoutchouc lors de toute intervention sur une pièce d'équipement sous tension. Les responsables de l'entretien doivent porter des chaussures isolantes pour prévenir tout contact direct avec le plancher.

Ne travaillez jamais seul, même si toute l'alimentation d'entrée est coupée de l'équipement. Une seconde personne devrait toujours être présente pour porter assistance ou chercher de l'aide en cas d'accident.



WARNING

Failure to follow adequate grounding procedures can result in electric shock hazard to personnel, or the risk of fire, should a ground fault occur.

All operations described in this section must be performed by properly trained and qualified electricians or technical personnel. If any difficulties are encountered, contact Vertiv™. See the back page of this manual for contact information.



AVERTISSEMENT

Le non-respect des procédures de mise à la terre peut entraîner des risques d'électrocution du personnel, ou des risques d'incendie en cas de défectuosité de la mise à la terre.









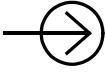

Toutes les opérations décrites dans cette section ne doivent être effectuées que par des électriciens ou des techniciens professionnels dûment formés et qualifiés. En cas de difficultés, communiquez avec Vertiv. Pour obtenir les renseignements de contact, consultez la dernière page de ce manuel.

NOTICE

Risk of improper electromagnetic shielding. Can cause radio communication interference.

This unit complies with the limits for a Class A digital device, pursuant to Part 15 Subpart J of the FCC rules. These limits provide reasonable protection against harmful interference in a commercial environment. This unit generates, uses and radiates radio frequency energy and, if not installed and used in accordance with this instruction manual, may cause harmful interference to radio communications. This unit is not designed for use in a residential area. Operation of this unit in a residential area may cause harmful interference that the user is solely responsible for correcting.

GLOSSARY OF SYMBOLS

	Risk of electrical shock
	Indicates caution followed by important instructions
	AC input
	AC output
	Requests the user to consult the manual
	Indicates the unit contains a valve-regulated lead acid battery
	Recycle
	DC voltage
	AC voltage
	Equipment grounding conductor
	Bonded to ground

1.0 INTRODUCTION

The Liebert® EXM UPS can be configured as either a fixed-capacity or scalable, transformer-free, online uninterruptible power system with 208/120V input and 208/120V output capability. The Liebert EXM can operate with either a 50 or 60Hz input and provide a matching output frequency conversion.

When configured for scalability, the UPS's capacity can be increased in 20kVA increments. Based on the configuration, a power module can be set to a redundant operation mode. Contact Vertiv Services about adding capacity.

Optional transformers are available to add 208V isolation or 480V or 600V input capability to the Liebert EXM in the optional Liebert BDC (Bypass Distribution Cabinet) and in the optional Liebert® EXM Dual Transformer Cabinet.

The Liebert EXM provides continuous, high-quality AC power to business-critical equipment, such as telecommunications and data processing equipment. The Liebert EXM supplies power free of the disturbances and variations in voltage and frequency common to utility power, which is subject to brownouts, blackouts, surges and sags.

The Liebert EXM utilizes the latest in high-frequency, double-conversion pulse width modulation (PWM) technology and fully digital controls to enhance its reliability and increase the ease of use.

The 10-40kVA/kW Liebert EXM includes internal batteries to support the load when utility power is not present.

1.1 Operator Control and Display Panel

Information about using the UPS control panel is detailed in SL-26200, available at Vertiv's Web site, www.vertiv.com

2.0 INSTALLATION

This section describes the Liebert® EXM's environmental requirements and mechanical considerations that must be taken into account when planning the positioning and cabling of the UPS equipment.

Because each site is unique, this section presents a guide to general procedures and practices that should be observed by the installing engineer, rather than step-by-step installation instructions.

NOTICE

Risk of improper installation. Can cause equipment damage.

Do not apply electrical power to the UPS equipment before the commissioning engineer arrives at the installation site.

The UPS must be installed by a properly trained and qualified engineer in accordance with the information contained in this chapter. All the equipment not referred to in this manual is shipped with details of its own mechanical and electrical installation information.



NOTE

Three-phase, four-wire input power is required.



NOTE

Input power must be supplied to the Liebert® EXM from a properly grounded Wye source. The Liebert® EXM is not for use with impedance grounded systems, corner-grounded systems or high-leg Delta systems. For these applications, an isolation transformer must be installed between the input power and the Liebert® EXM.

2.1 Initial Inspections

1. While the Liebert® EXM and ancillary cabinets are still on the truck, inspect the equipment and shipping container for any signs of damage or mishandling. Do not attempt to install the system if damage is apparent. If any damage is noted, file a damage claim with the shipping agency immediately and contact Vertiv Services at 800-543-2378 to inform them of the damage claim and the condition of the equipment.
2. Compare the contents of the shipment with the bill of lading. Report any missing items to the carrier and your local Vertiv™ representative immediately.
3. Check the product label on the back of front door and confirm the contents match the UPS model, capacity and main parameters that were ordered.

2.1.1 Storing the UPS and Batteries for Delayed Installation

If the Liebert® EXM system will not be installed immediately, it must be stored indoors in a clean, dry and cool location (see **7.2 - UPS Environmental**). If the UPS includes batteries, either internally or in a battery cabinet, the batteries' requirements will dictate the storage conditions. Batteries should be unpacked, installed and charged as soon as possible after delivery.

NOTICE

Risk of failure to properly charge batteries. Can cause permanent damage to batteries and void the warranty.

Batteries will self-discharge during storage. Batteries must be recharged as recommended by the battery manufacturer.

A notice of "Charge Before Date" is affixed to each unit that has batteries inside. The "Charge Before Date" is calculated based on the batteries being stored at 77°F (25°C). Storage at a higher temperature will increase the rate of self-discharge, requiring earlier recharge. Consult the battery manufacturer on how to determine when the batteries need to be recharged.

2.2 Preliminary Checks

2.2.1 Identification

The equipment supplied has an identification tag on the back of the main door listing the type and size of the UPS.

2.3 UPS Location

2.3.1 Positioning the UPS

Choose a location for the UPS that offers:

- Easy connection to inputs, outputs and auxiliary equipment
- Enough space to service the UPS
- Air circulation sufficient to expel heat produced by UPS
- Protection against moisture and excessive humidity
- Protection against dust and other particulate matter
- Compliance with fire prevention regulations and practices
- Operating environment temperature of 74-80°F (23-27°C) for maximum battery life

2.3.2 Environmental Considerations

Before installing the Liebert® EXM, verify that the UPS room satisfies the environmental conditions stipulated in **7.2 - UPS Environmental**, paying particular attention to the ambient temperature and air exchange system.

The UPS unit should be installed in a cool, dry, clean-air environment with adequate ventilation to keep the ambient temperature within the specified operating range 32°F to 104°F (0°C to 40°C).

For optimal UPS system performance and service life, maintain the operating temperature within the range of 74-80°F, (23-27°C).

The Liebert® EXM is cooled by internal fans. Cooling air enters the unit through the front of the unit and is exhausted out the top. To permit proper air flow and prevent overheating, do NOT block or cover the ventilation openings or blow air down onto the unit. The UPS requires 24 in. (610mm) ventilation clearance above the unit.

See **Table 19** for details on heat dissipation.

2.4 Battery Location

Temperature is a major factor in determining battery life and capacity. Battery manufacturers recommend an operating temperature of 77°F (25°C). Ambient temperatures warmer than this reduce battery life; temperatures below this reduces battery capacity. In a typical installation, battery temperature should be maintained between 74°F and 80°F (23-27°C). Batteries should be placed where there are no main heat sources or air inlets to prevent portions of batteries from being either much warmer or much cooler than other parts of the batteries.

2.5 Considerations in Moving the Liebert EXM

Ensure that the UPS weight is within the designated surface weight loading (lb./ft² or kg/cm²) of any handling equipment. See **Table 14** for weights of various units.

The Liebert® EXM may be rolled on its casters for short distances only. For longer distances, move the UPS with a forklift or similar equipment to ease the relocation and to reduce vibration.



WARNING

Risk of moving heavy unit. Can cause property damage, injury and death.

Ensure that any equipment that will be used to move the Liebert® EXM has sufficient lifting capacity. The Liebert EXM's weight ranges from 809 to 956 lb. (367 to 434kg) without batteries. Refer to **Table 1** for the unit's weight with batteries.

The UPS presents a tipping hazard. Do not tilt the Liebert® EXM more than 15 degrees from vertical.

The UPS is fitted with casters—Take care to prevent movement when unbolting the equipment from its shipping pallet. Ensure adequate personnel and lifting equipment are available when taking the Liebert® EXM off its shipping pallet.

AVERTISSEMENT

Le poids élevé de l'appareil peut entraîner des dommages matériels, des blessures et même la mort. Veillez à ce que les équipements utilisés pour déplacer le système EXM de Liebert possèdent une capacité nominale suffisante. Le poids du système EXM de Liebert varie entre 367 et 434 kg (809 et 956 lb) sans les batteries. Reportez-vous au **Tableau 1** pour connaître le poids de l'appareil avec les batteries. Le système ASC présente un risque de renversement. N'inclinez pas le système EXM de Liebert à plus de 15 degrés de la verticale.

Comme le système ASC est équipé de roulettes, veillez à éviter les mouvements involontaires lorsque vous déboulonnez l'équipement de sa palette d'expédition. Veillez à ce qu'un personnel approprié et un dispositif de levage soient disponibles lorsque vous retirez le système EXM de Liebert de la palette d'expédition.

WARNING

Risk of heavy unit tipping over while being moved. Can cause property damage, injury and death. The casters are strong enough for movement across even surfaces only. Casters may fail if they are subjected to shock loading, such as being dropped or rolled over holes in the floor or obstructions. Such failure may cause the unit to tip over, injuring personnel and damaging the equipment.

AVERTISSEMENT

Le centre de gravité élevé de l'appareil présente un risque de renversement lors des déplacements, peut entraîner des dommages matériels, des blessures et même la mort.

Les roulettes sont suffisamment résistantes pour le déplacement sur des surfaces planes uniquement. Les roulettes peuvent être endommagées si vous les soumettez à des impacts, notamment en cas de chute ou de passage sur des obstacles ou trous dans le plancher. Une telle défaillance peut causer le renversement de l'appareil, qui risque de blesser le personnel et d'endommager l'équipement.

Final Positioning

When the equipment has been finally positioned, ensure that the adjustable stops are set so that the UPS will remain stationary and stable (see **4.0 - Installation Drawings**).

The Liebert® EXM and its auxiliary cabinets must be installed on a concrete or equivalent, non-resilient floor.

2.6 Mechanical Considerations

The Liebert® EXM is constructed with a steel frame and removable panels. Top and side panels are secured to the chassis by screws. The doors may be opened for access to power connection bars, auxiliary terminal blocks and power switches.

The UPS comes with an Operator Control Panel that provides basic operational status and alarm information. The cabinet houses the power components. Cooling is provided by internal fans. The unit sits on four casters. Adjustable stops are provided to prevent the UPS from moving once it has been moved to its final position.

WARNING

Risk of heavy units tipping over while being moved. Can cause property damage, injury and death.

AVERTISSEMENT

Le centre de gravité élevé des appareils présente un risque de renversement lors des déplacements, peut entraîner des dommages matériels, des blessures et même la mort.

2.6.1 Dimensions

Figure 1 UPS dimensions

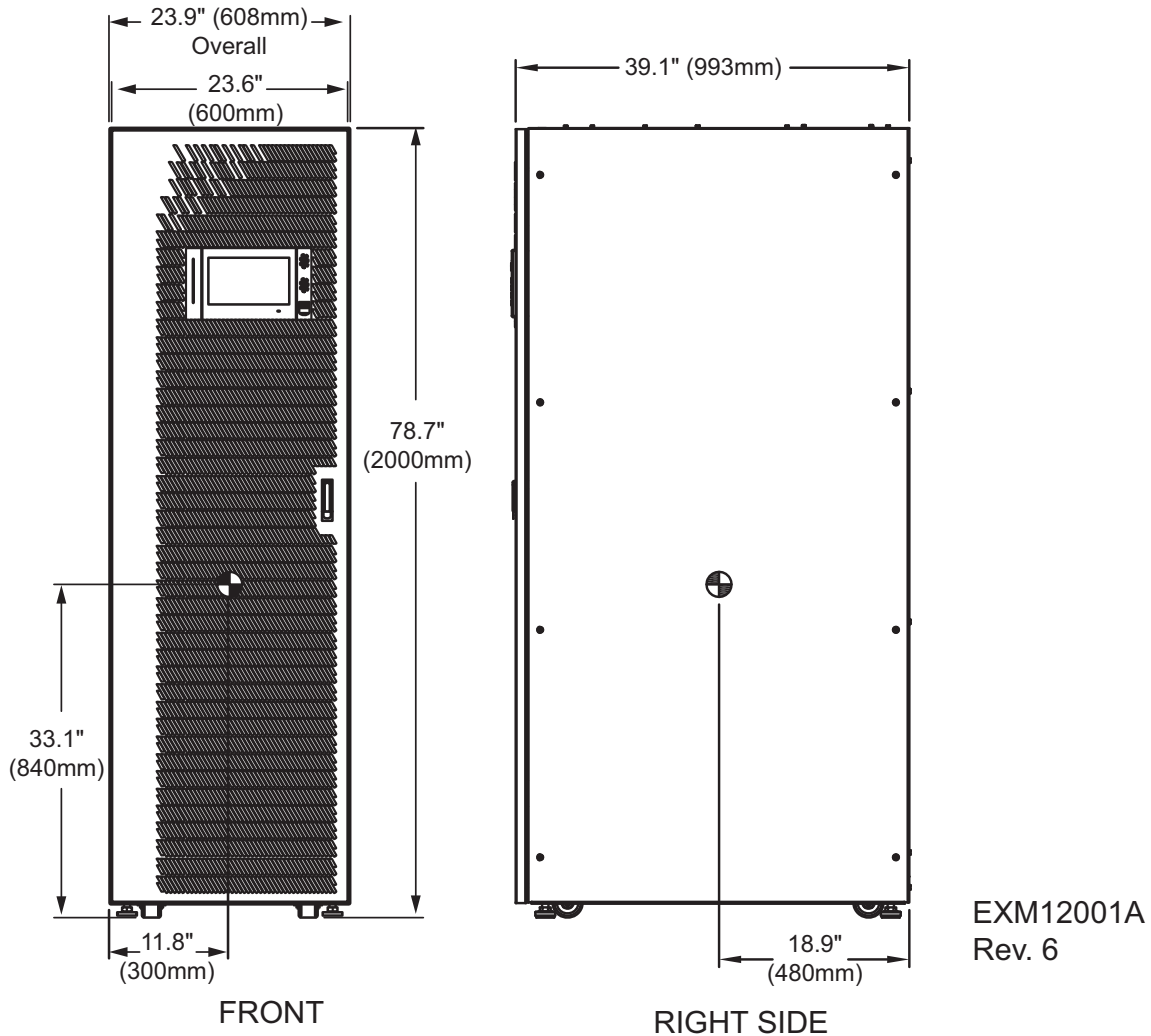

EXM12001A
Rev. 6

Table 1 Weights for Liebert® EXM 10-40kVA frame

UPS Rating, kVA	No Internal Batteries	12HX100	12HX150E	12HX205	HR1500	HR2000
10	684 (310)	1212 (550)	1308 (593)	1716 (778)	1332 (812)	1644 (746)
15	684 (310)	1212 (550)	1308 (593)	1716 (778)	1332 (812)	1644 (746)
20	684 (310)	1212 (550)	1308 (593)	1716 (778)	1332 (812)	1644 (746)
30	758 (344)	N/A	1382 (627)	1790 (812)	1406 (638)	1718 (779)
40	758 (344)	N/A	N/A	1790 (812)	N/A	1718 (779)

Add 100 lb. (45 kg) for shipping weights.

2.6.2 Clearances

Provide at least the minimum clearance required by NEC on all sides of Liebert® EXM, including 36" (914mm) in front, to permit routine tightening of power terminations within the UPS and free passage of personnel with the door fully opened. Depending on the floor anchoring system used, up to 5" (127mm) may be required in the rear of the UPS.

There are no ventilation grilles on the sides or back of the UPS.

Leave a minimum of 24 in. (610mm) between the top of the UPS frame and the ceiling to permit adequate air circulation above the unit. Vertiv™ recommends against using air conditioning or other systems that blow air onto the top of the unit.

Figure 2 Clearances—Front, side and rear

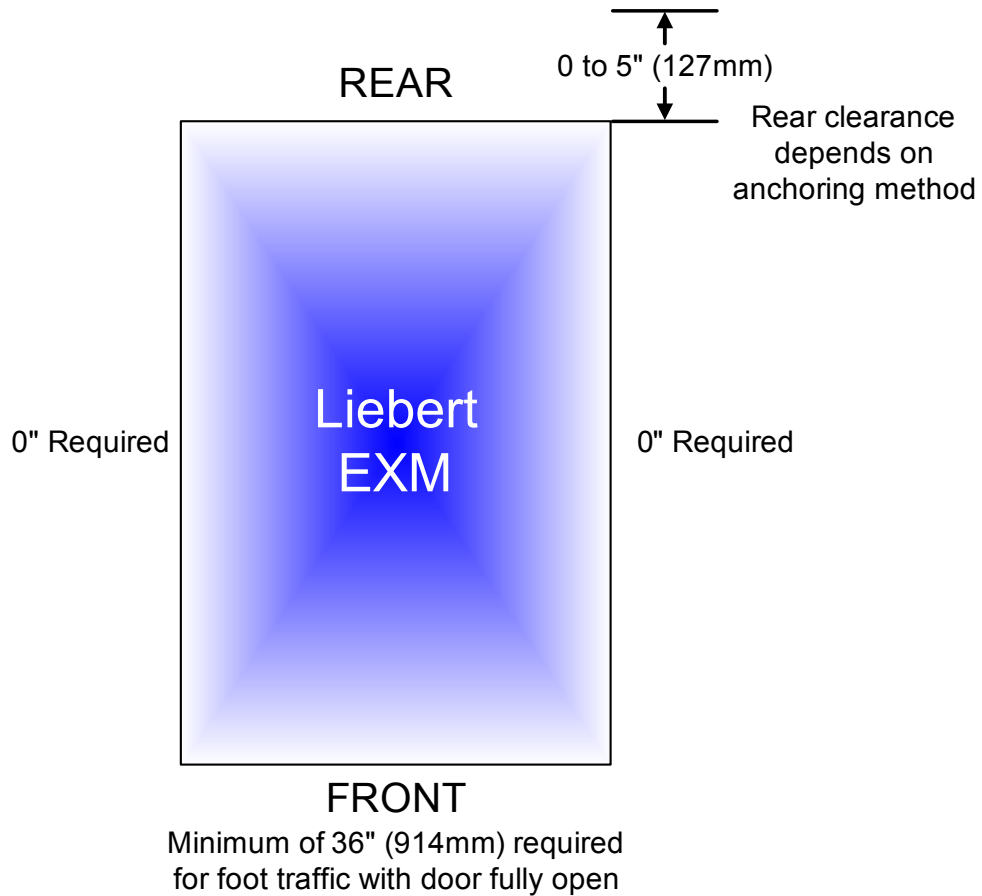

2.6.3 Floor Installation

If the Liebert® EXM is to be placed on a raised floor, the UPS should be mounted on a pedestal that will support the equipment point loading. Refer to the bottom view in **Figure 1** to design this pedestal.

2.6.4 Cable Entry

Cables can enter the Liebert® EXM from the top or bottom through removable metal plates.

Some plates have factory-punched holes and others are designed to allow the personnel to punch holes for fitting and securing the conduit. Once the conduit holes are punched, these plates should be reattached to the UPS. The conduit size and wiring method must be in accordance with all local, regional and national codes and regulations, including NEC ANSI/NFPA 70.

The UPS must be accessible from the front to allow personnel to complete the cable connections and make necessary adjustments.



NOTE

When installing the UPS, the customer must provide a disconnect with overcurrent protection at the output of the UPS.

Figure 3 Cable entry locations

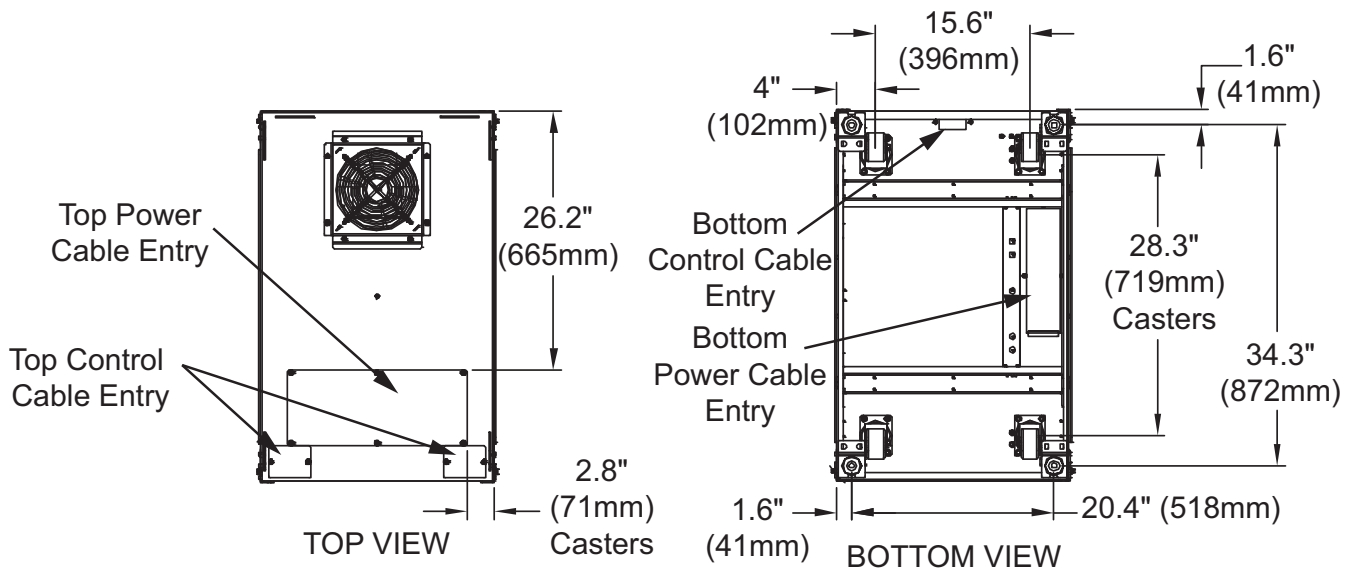

2.7 Auxiliary Cabinets

The Liebert® EXM 10-40kVA UPS can be integrated with the following auxiliary cabinets:

Battery Cabinets—Optional Liebert® EXM Battery Cabinets are available for each Liebert® EXM model to provide extended run times, large battery system solutions and optional integrated Alber® battery monitoring. The battery cabinets are designed to be bolted to the left side of the UPS (see **Figure 4**). Refer to SL-25651, the Liebert® EXM Battery Cabinet manual, for details.

Maintenance Bypass Cabinets—Optional Liebert® EXM Bypass Cabinets are available to provide a full or partial wraparound maintenance bypass for servicing the UPS. Liebert bypass cabinets are designed to be bolted to the right side of the UPS (see **Figure 4**). Refer to SL-25652, the Liebert® EXM Maintenance Bypass Cabinet manual, for further details.

Bypass Distribution Cabinet—Optional Liebert® EXM Bypass Distribution Cabinets are available to provide a full wraparound maintenance bypass for servicing the UPS with optional input transformer and output distribution. Liebert bypass cabinets are designed to be bolted to the right side of the UPS (see **Figure 4**). Refer to SL-25653, the Liebert® EXM Bypass Distribution Cabinet manual, for further details.

Paralleling Cabinet—Optional Liebert® EXM Paralleling Cabinets are available to provide connections enabling parallel operation of up to three Liebert® EXM UPS’s in applications offering increased capacity and redundant protection (1+1, 2+0, 2+1). A partial wraparound maintenance bypass for servicing of the parallel UPS system is included. Refer to SL-25654, the Liebert® EXM Paralleling Cabinet manual, for further details.

Dual Transformer Cabinet—Optional Liebert® EXM Dual Transformer Cabinets are available to provide step-down voltage transformation for dual-input UPS applications. Refer to SL-25655, the Liebert® EXM Dual Transformer Cabinet manual, for further details.

System Composition

A UPS system can comprise a number of optional equipment cabinets, depending on the system design requirements—e.g., UPS cabinet, External Battery Cabinet and External Bypass Cabinet. All cabinets used will be the same height and will be designed to be positioned side-by-side to form an aesthetically appealing equipment suite.

Figure 4 Cabinet arrangement

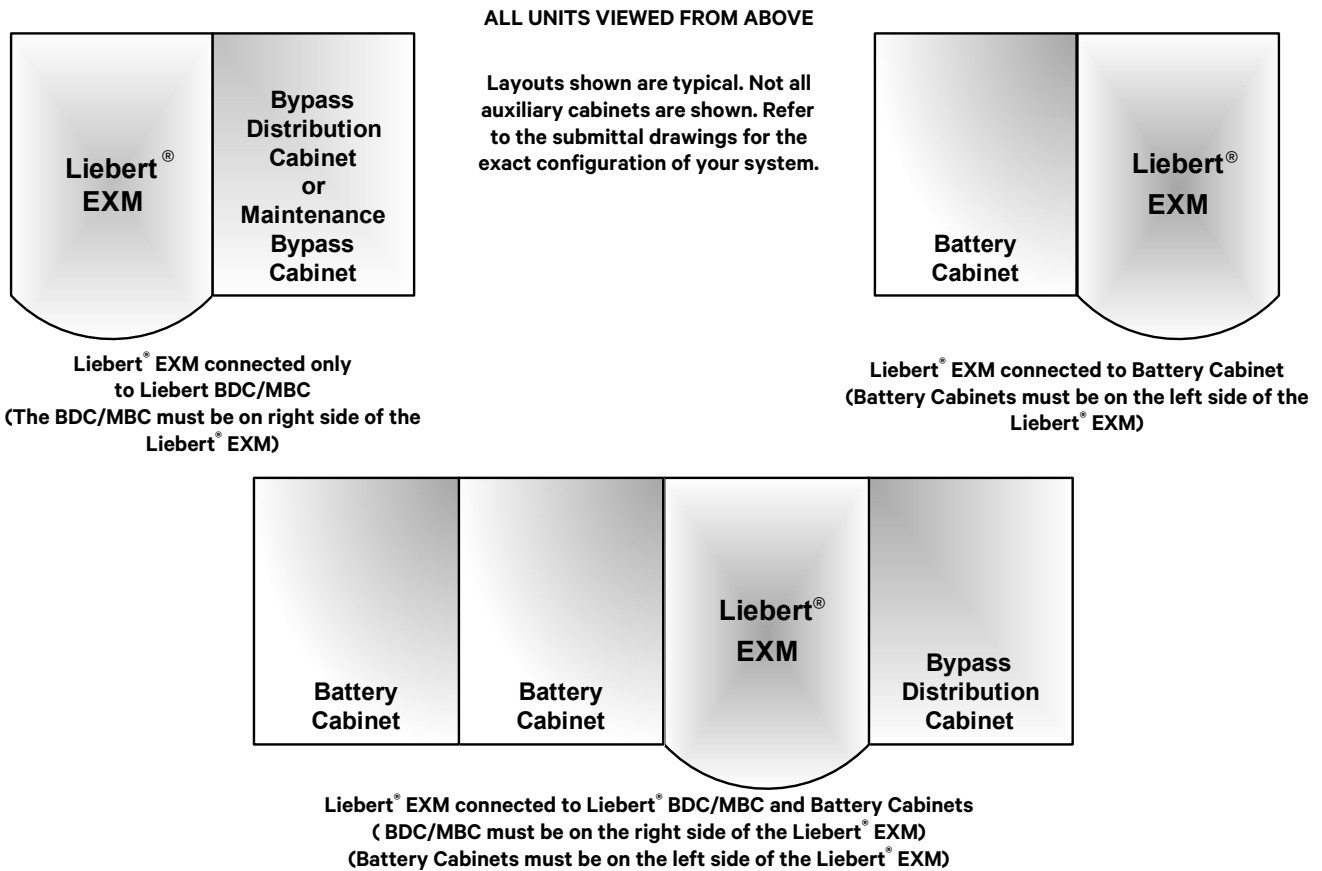

2.8 Power Module Assembly

Figure 5 Power Module Assembly indicators and controls

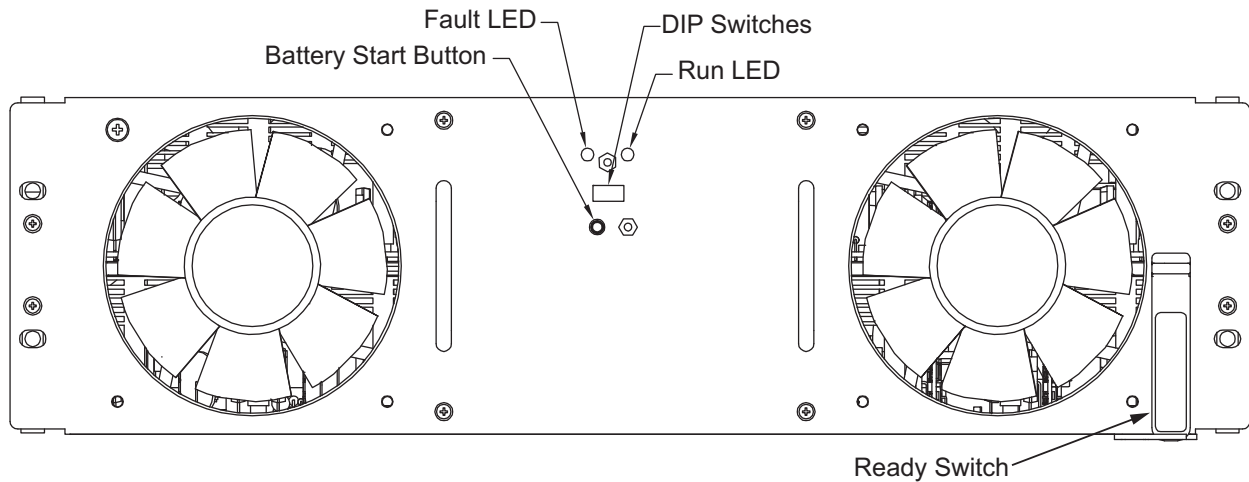

The *Battery Start* button allows starting the UPS on battery.

The Run LED is illuminated Green when the Liebert Power Module Assembly is operating normally.

The Fault LED will illuminate red when the Liebert Power Module Assembly has a problem.

Table 2 LED indications on power module assembly

LED Status	Indication
Run LED (Green)	
Flashing Green	The inverter is starting, but has no output yet.
Constant Green	The inverter has started to supply power.
OFF	The inverter has not started up.
Fault LED (Red)	
Constant Red	Auxiliary power failure (15V or 24V), rectifier overtemperature, rectifier failure (including battery SCR short circuit), battery converter failure, soft start failure, main circuit back feed, abnormal input current, inverter failure, output short circuit, bypass SCR short circuit fault, inverter relay short circuit fault, abnormal bus voltage, module not ready, module ID out of range and duplicated module ID.
Flashing Red	Charger failure, abnormal main circuit voltage, abnormal main circuit frequency, main circuit undervoltage, main circuit reverse phase, battery unavailable, reverse battery, input zero-loss, current sharing failure, module overload, inverter relay disconnection fault, bypass SCR disconnection fault and input fuse blown.
OFF	No above failures or alarms.

2.9 Static Bypass Assembly

Figure 6 Static Bypass Assembly connections

See Figures 15- 18 for details.

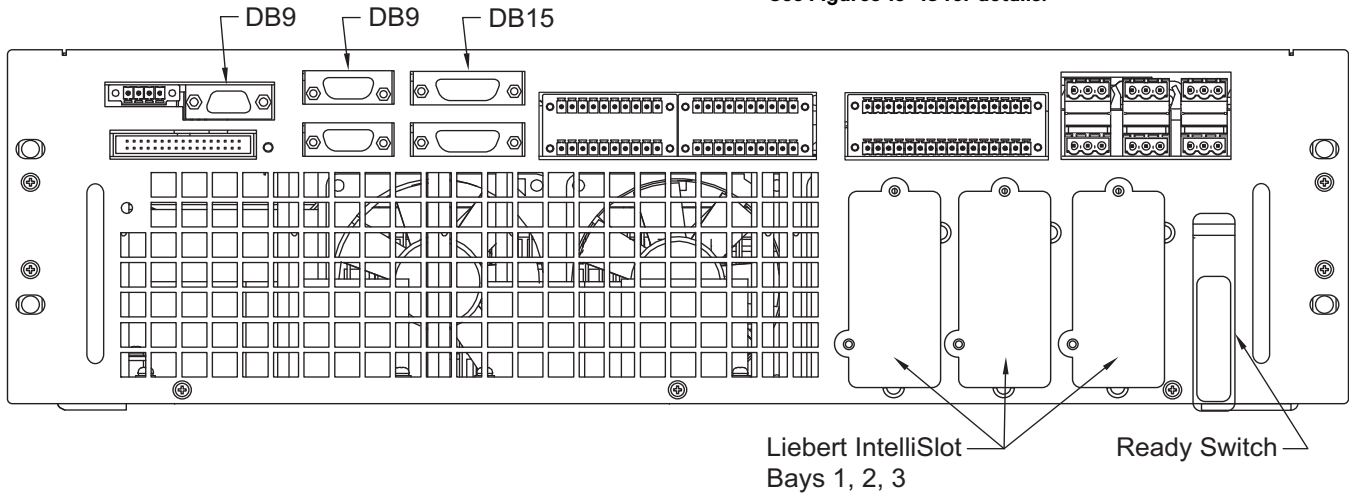

The Static Bypass Assembly has three Liebert IntelliSlot interface card bays and connections for optional ancillary cabinets and for other options.

3.0 ELECTRICAL CONNECTIONS—UPS

The UPS requires both power and control cabling once it has been mechanically installed. All control cables must run separate from power cables in metal conduits or metal ducts that are electrically bonded to the metalwork of the cabinets to which they are connected.



WARNING

Risk of electric shock. Can cause property damage, injury and death.

Before connecting input power to the Liebert EXM, ensure that you are aware of the location and operation of the overcurrent protection devices that connect the UPS input/bypass supply to the power distribution panel.

De-energize and lockout or tagout all incoming high- and low-voltage power circuits before installing cables or making any electrical connections.



AVERTISSEMENT

Risque de décharge électrique pouvant entraîner des dommages matériels, des blessures et même la mort.

Avant de procéder au branchement de l'alimentation d'entrée du système EXM de Liebert, veuillez à prendre connaissance de l'emplacement et du fonctionnement des dispositifs de protection de surintensité qui raccordent l'alimentation d'entrée ou de dérivation du système ASC au panneau de distribution électrique.

Coupez l'alimentation et appliquez le verrouillage ou l'étiquetage à tous les circuits d'alimentation haute tension et basse tension avant d'installer les câbles ou d'effectuer tout autre branchement électrique.

3.1 Power Cabling

3.1.1 Lug Size and Cable Rating

The main factors affecting the choice and size of cable are voltage, current (also taking into account overcurrent), room temperature and conditions of installation of the cable. Refer to ANSI/NFPA 70.

The power cables of the system must be sized with respect to the following description:

- **UPS input cables**—The UPS input cables must be sized for the maximum input current, including the maximum battery recharge current, given in **Table 15**, with respect to the unit rating and the input AC voltage.
- **UPS bypass and output cables**—The bypass and output cables must be sized for the nominal output current, given in **Table 15**, with respect to the unit rating and the output AC voltage.
- **Battery cables**—See the Liebert® EXM External Battery Cabinet manual, SL-25651, for battery installation guidelines and instructions. The manual ships with the battery cabinet and is available at Vertiv's Web site: www.vertiv.com



NOTE

Table 15 gives nominal currents for determining the size of UPS power cables. Other important factors to consider include cable route length and coordination with protective devices.

The power cables can be sized to suit the UPS unit rating according to **Table 15**.

Torque Requirements

Refer to **Tables 3** and **4** for lug size and torque requirements.

Table 3 Busbars (for power wiring)

Bolt Shaft Size	Lb-in (Nm)
3/8" (M10)	192 (22)

Table 4 Terminal block with compression lugs (for control wiring)

AWG Wire Size or Range	Lb-in (Nm)
#22 - #14	3.5 to 5.3 (0.4 to 0.6)

3.2 External Protective Devices

For safety concerns, it is necessary to install external circuit breakers or other protective devices for the input AC supply of the UPS system. This section provides generic practical information for qualified installation engineers. The installation engineers should be knowledgeable about regulatory wiring standards and the equipment to be installed.

To reduce the risk of fire, connect only to a circuit provided with branch circuit overcurrent protection in accordance with NEC ANSI/NFPA 70.

3.2.1 Rectifier and Bypass Input Supply of the UPS

Overcurrents

Install suitable protective devices in the distribution unit of the incoming mains supply, considering the power cable current-carrying capacity and overload capacity of the system. Generally, the magnetic circuit breaker with IEC60947-2 tripping curve C (normal) at the 125% of the nominal current listed in **Table 15** is recommended.

Split bypass: In case a split bypass is used, separate protective devices should be installed for the rectifier input and bypass input in the incoming mains distribution panel. A shunt trip coil of 120V must be installed in the bypass and rectifier input breakers if the system does not include a Liebert Bypass Cabinet.



NOTE

The rectifier input and bypass input must use the same neutral line.

Earth Leakage, RCD Devices

Any residual current detector (RCD) installed upstream of the UPS input supply:

- Must be sensitive to DC unidirectional pulses (Class A)
- Must be insensitive to transient current pulses, and
- Must have an average sensitivity, adjustable between 0.3 and 1A.

To avoid false alarms, earth leakage monitoring devices when used in systems with split bypass input or when used in paralleled UPS configurations, must be located upstream of the common neutral sinking point. Alternatively, the device must monitor the combined four-wire rectifier and split bypass input currents.

3.2.2 UPS Output

If an external distribution panel is used for load distribution, the selection of protective devices must provide discrimination with those that are used at the input to the UPS (see **Table 20**).

3.2.3 UPS Input Configuration

By default, the Liebert® EXM ships with internal links installed between the bypass input and main (rectifier) input (single input configuration).

Figures 7 and **8** show the Liebert® EXM in a split bypass (single source dual-input) configuration. In this configuration, the static bypass and the maintenance bypass lines are supplied by the same source using separate feeds. Both feeds must be protected externally with properly sized protective devices.

Wire Liebert EXM as Single Source Dual-Input

To wire the Liebert® EXM as a single source dual-input UPS, remove the factory-installed links between the Rectifier and the Bypass input busbar (see **Figure 10**).

Figure 7 Single UPS block diagram—Dual input, single source configuration, without bypass cabinet

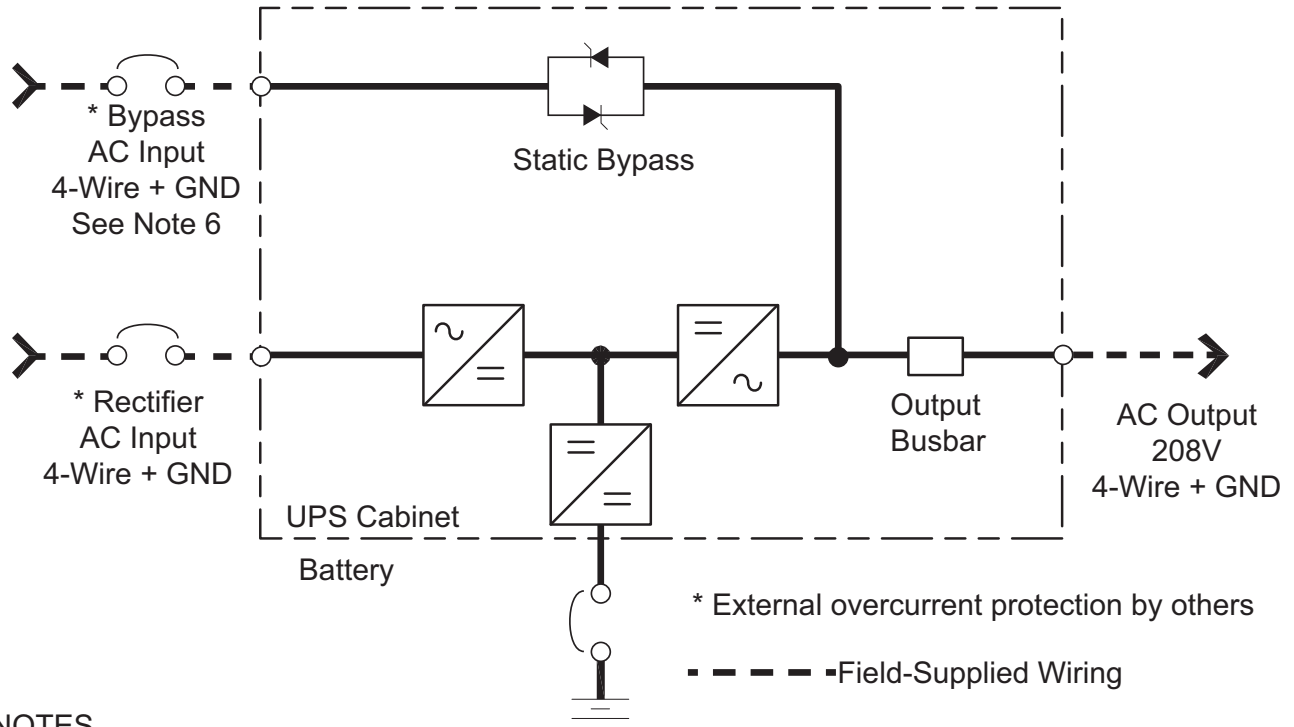

NOTES

1. Install in accordance with national and local electrical codes.
2. Input and bypass must share the same single source.
3. A neutral is required from the system AC input source. Vertiv recommends a full-capacity neutral conductor and grounding conductors.
4. Bypass and rectifier inputs and output cables must be run in separate conduits.
5. Control wiring must be run in separate conduits.
6. Customer must supply shunt trip breakers with 120V coils to the bypass and rectifier.

Figure 8 Single UPS block diagram—Dual input, single source configuration

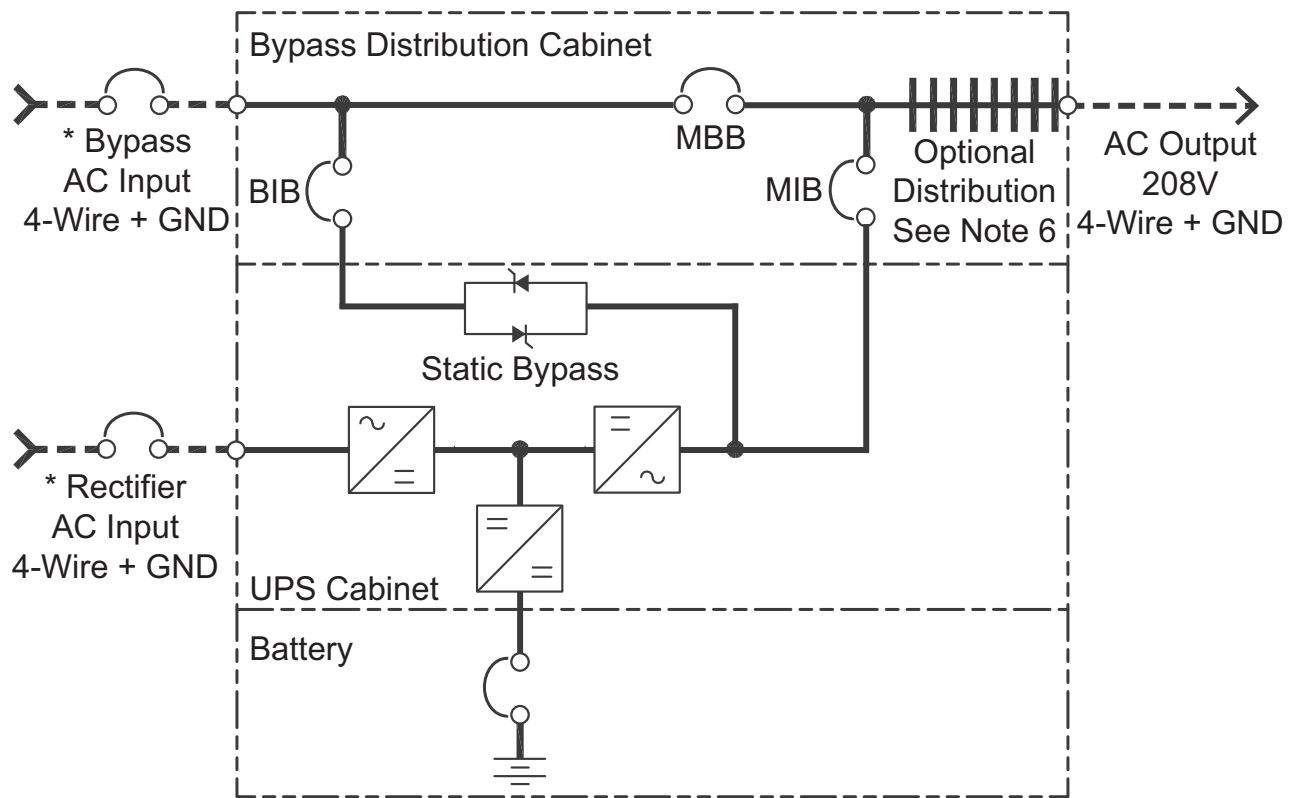

NOTES

1. Install in accordance with national and local electrical codes.
2. Input and bypass must share the same single source.
3. A neutral is required from the system AC input source. Vertiv recommends a full capacity neutral conductor and grounding conductors.
4. Bypass and rectifier inputs and output cables must be run in separate conduits.
5. Control wiring must be run in separate conduits.
6. Optional 54-pole, 225A distribution panel.
7. Customer must supply a shunt trip breaker with 120V coil. If an optional Liebert BDC is not present, the shunt trip must be installed to the bypass and rectifier breaker.

BIB - Bypass Isolation Breaker
 MBB - Maintenance Bypass Breaker
 MIB - Maintenance Isolation Breaker
 * External Overcurrent Protection by others
 - - - - Field-Supplied Wiring

3.2.4 UPS Input Configuration with Transformers

Figure 9 shows the Liebert® EXM in a split bypass (dual-source, dual-input) configuration using two transformers inside a dual-transformer cabinet.

In this configuration, the static bypass and the rectifier lines can be supplied by independent sources. The Liebert® EXM Dual Transformer Cabinet is the only approved method for supplying the EXM from two independent sources. See SL-25655 for details. Both feeds must be protected externally with properly sized protective devices.

Figure 9 Liebert® EXM in a split bypass configuration

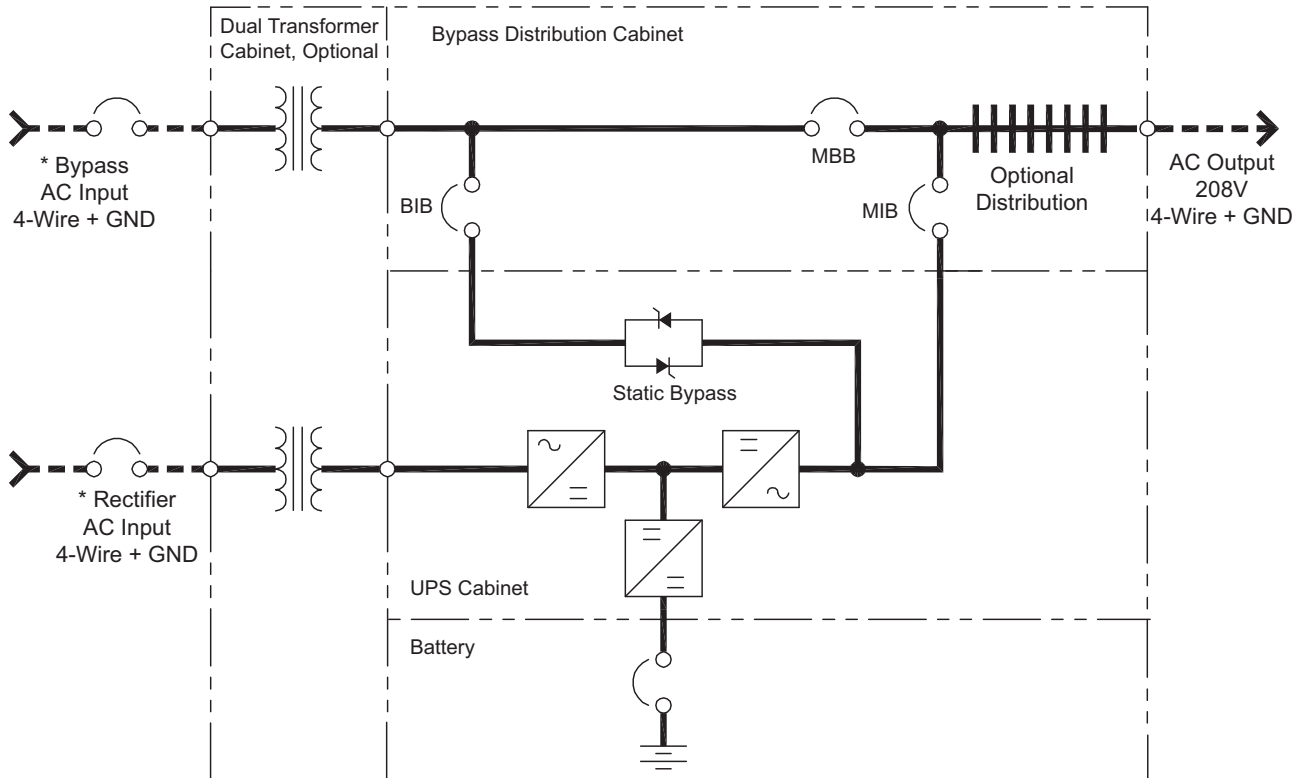

1. Install in accordance with national and local electrical codes.
2. Input and bypass must share the same single source.
3. A neutral is required from the system AC input source. Vertiv recommends a full capacity neutral conductor and grounding conductors.
4. Bypass and rectifier inputs and output cables must be run in separate conduits.
5. Control wiring must be run in separate conduits.
6. Optional 54-pole, 225A distribution panel.

3.2.5 Cabling Guidelines

The following are guidelines only and are superseded by local regulations and codes of practice where applicable. Use wiring rated at 75°C or greater.

1. Take special care when determining the size of the neutral cable, as current circulating on the neutral cable may be greater than nominal current in the case of non-linear loads. Refer to the values in **7.3 - UPS Electrical Characteristics**.
2. The ground conductor should be sized according to such factors as the fault rating, cable lengths and type of protection. The ground cable connecting the UPS to the main ground system must follow the most direct route possible. Control wiring and power wiring must be run in separate conduit. Output and input cables must be run in separate conduit.
3. Consider using paralleled smaller cables for heavy currents—this can ease installation.
4. Refer to SL-25651 for guidelines and instructions when sizing battery cables for optional external battery cabinets.
5. In most installations, the load equipment is connected to a distribution network of individually protected busbars fed by the UPS output, rather than connected directly to the UPS itself. When this is the case, the UPS output cables can be rated to suit the individual distribution network demands rather than being fully load-rated.



NOTE

If more load is added to the distribution panel, the unit's cabling must be resized.

6. When laying power cables, do not form coils; this will help avoid increasing formation of electromagnetic interference.

3.2.6 Cable Connections

The rectifier input, bypass, output and battery are easily accessible from the front of the unit for installation. All require lug type terminations. They are connected to busbars on the front of the Liebert® EXM, as shown in **Figure 10**. These busbars are accessible when the I/O panel is removed.

NOTICE

Risk of improper installation. Can cause equipment damage.

When wiring a single-input only system, connect only the power wiring to the input busbars.

Figure 10 Input busbars—Liebert® EXM 10-40kVA frame

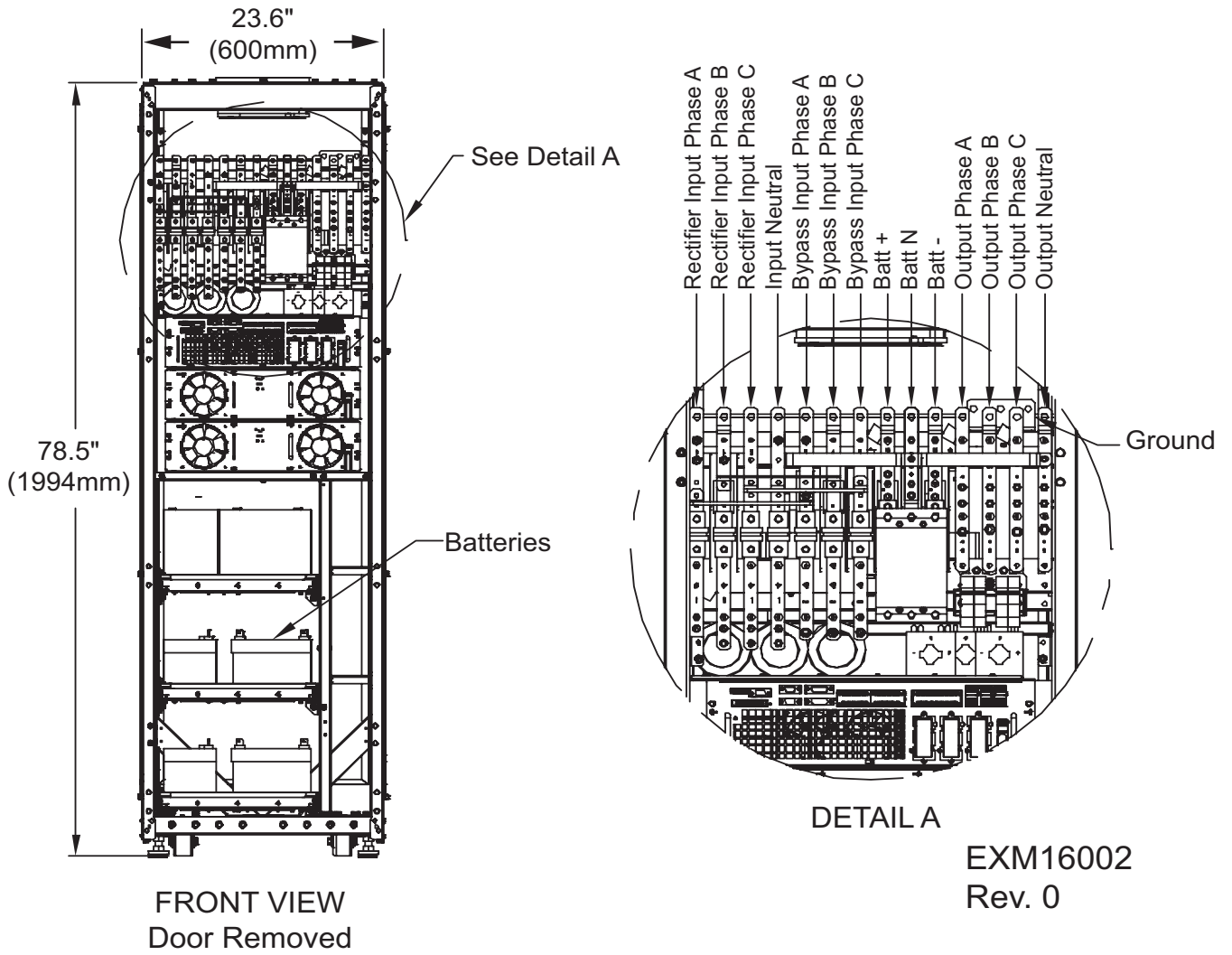

3.2.7 Accessory Fuses and Back-Feed Breaker Wiring

Two fuse blocks provide power for the back-feed breakers (standard) and the Alber® BDSUi (optional). The fuse blocks are at the lower right of the I/O panel on the front of the Liebert® EXM UPS. See **Figure 11** for fuse-holder locations.

The back-feed breaker fuse block provides 120V nominal provided from the UPS output (L-N) and the fuse is rated for 2 amps. **Figure 12** shows the back-feed breaker wiring, located on the bypass static switch assembly.

The Liebert® EXM does not include internal back-feed protection. A shunt trip coil of 120V must be installed in the bypass and rectifier input breakers if the system does not include a Liebert Bypass Cabinet. This is a safety feature and will prevent the UPS inverter from back-feeding the input source.

The Alber BDSUi fuse block provides 208V nominal from the UPS output (L-L) and the fuse is rated at 8A. The Alber BDSUi power wiring is shown in SL-25651, the Liebert® EXM Battery Cabinet manual.

Figure 11 Accessory fuses

Back-Feed Breaker
Fuse Block

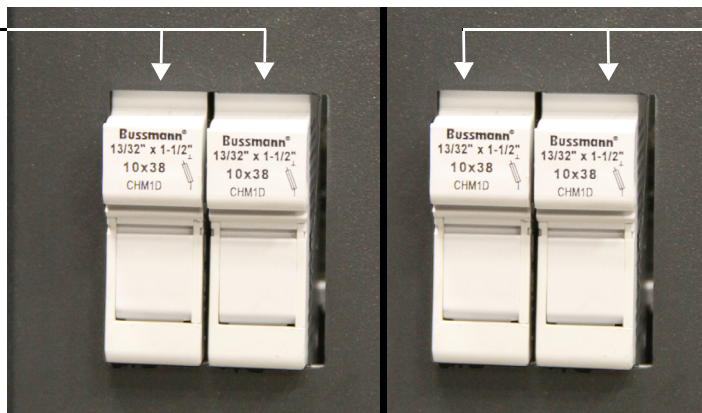

Alber BDSUi Fuse
Block (optional)

Figure 12 Dual input back-feed breaker wiring when bypass distribution cabinet not used

1. Auxiliary contacts not needed for backfeed breaker operation.
2. A 120V shunt trip coil is required for proper operation.

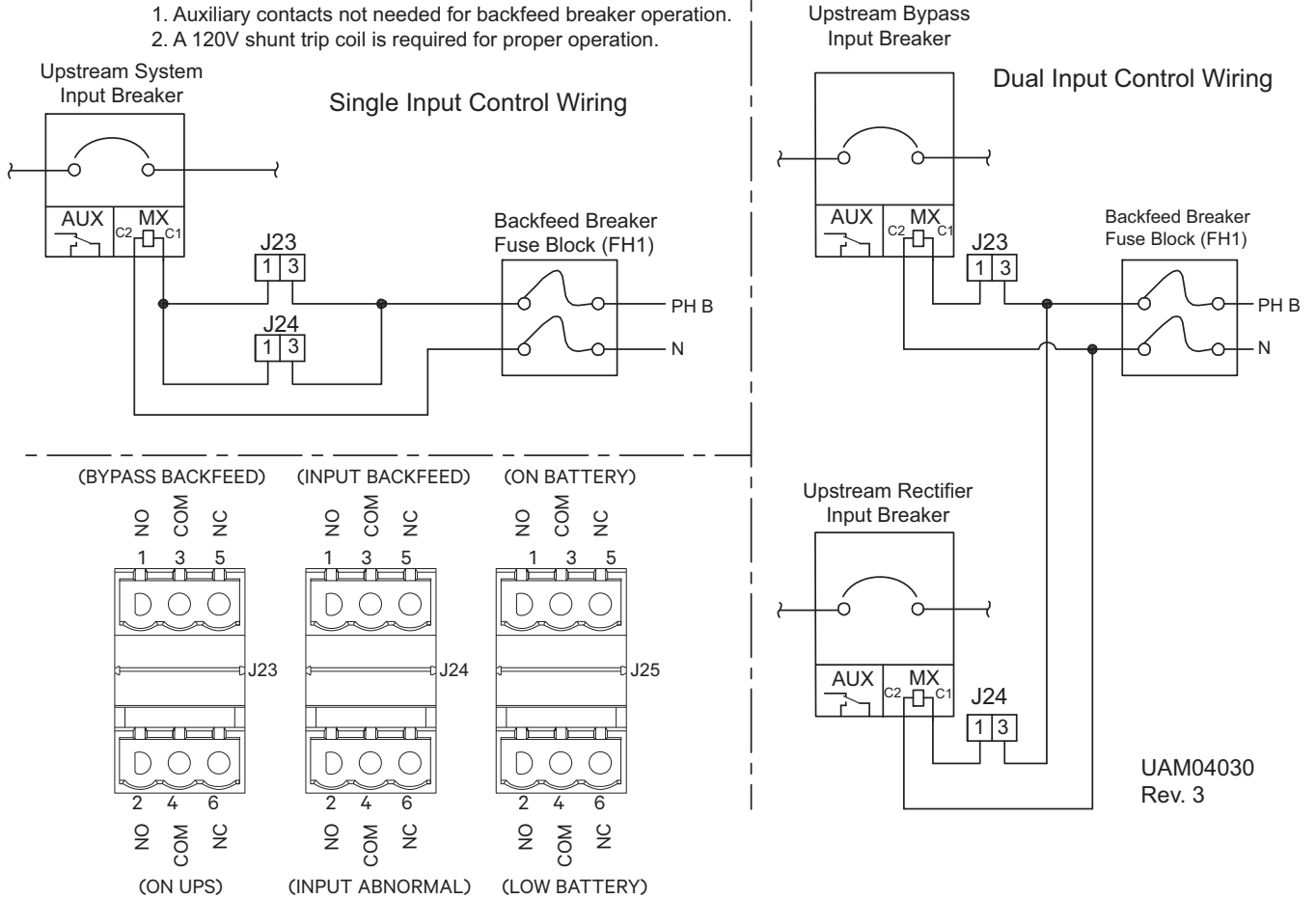

UAM04030
Rev. 3



NOTE

A shunt trip of the upstream Rectifier Input Breaker and Bypass Input Breaker is required.

3.2.8 Safety Ground

The safety ground busbar is below the neutral input and output busbars as shown in **Figure 13** below. The safety ground cable must be connected to the ground busbar and bonded to each cabinet in the system. This ground busbar is then connected to the ground electrode conductor (GEC).

All cabinets and cable conduit should be grounded in accordance with local regulations.



WARNING

Failure to follow adequate grounding procedures can result in electric shock hazard to personnel, or the risk of fire, should a ground fault occur.

All operations described in this section must be performed by properly trained and qualified electricians or technical personnel. If any difficulties are encountered, contact Vertiv™. See the back page of this manual for contact information.



AVERTISSEMENT

Le non-respect des procédures de mise à la terre peut entraîner des risques d'électrocution du personnel, ou des risques d'incendie en cas de défektivité de la mise à la terre.

Toutes les opérations décrites dans cette section ne doivent être effectuées que par des électriciens ou des techniciens professionnels dûment formés et qualifiés. En cas de difficultés, communiquez avec Vertiv. Pour obtenir les renseignements de contact, consultez la dernière page de ce manuel.



NOTE

Proper grounding significantly reduces problems caused by electromagnetic interference.



NOTE

The ground and neutral busbars are easily accessible when the I/O panel is removed. Cable connections should be made before a cabinet is attached to the right side of the Liebert® EXM or before the UPS is placed where another obstruction, such as a wall, is against the Liebert EXM's the right side.

Figure 13 Ground and neutral busbar connections—10-40kVA frame busbars

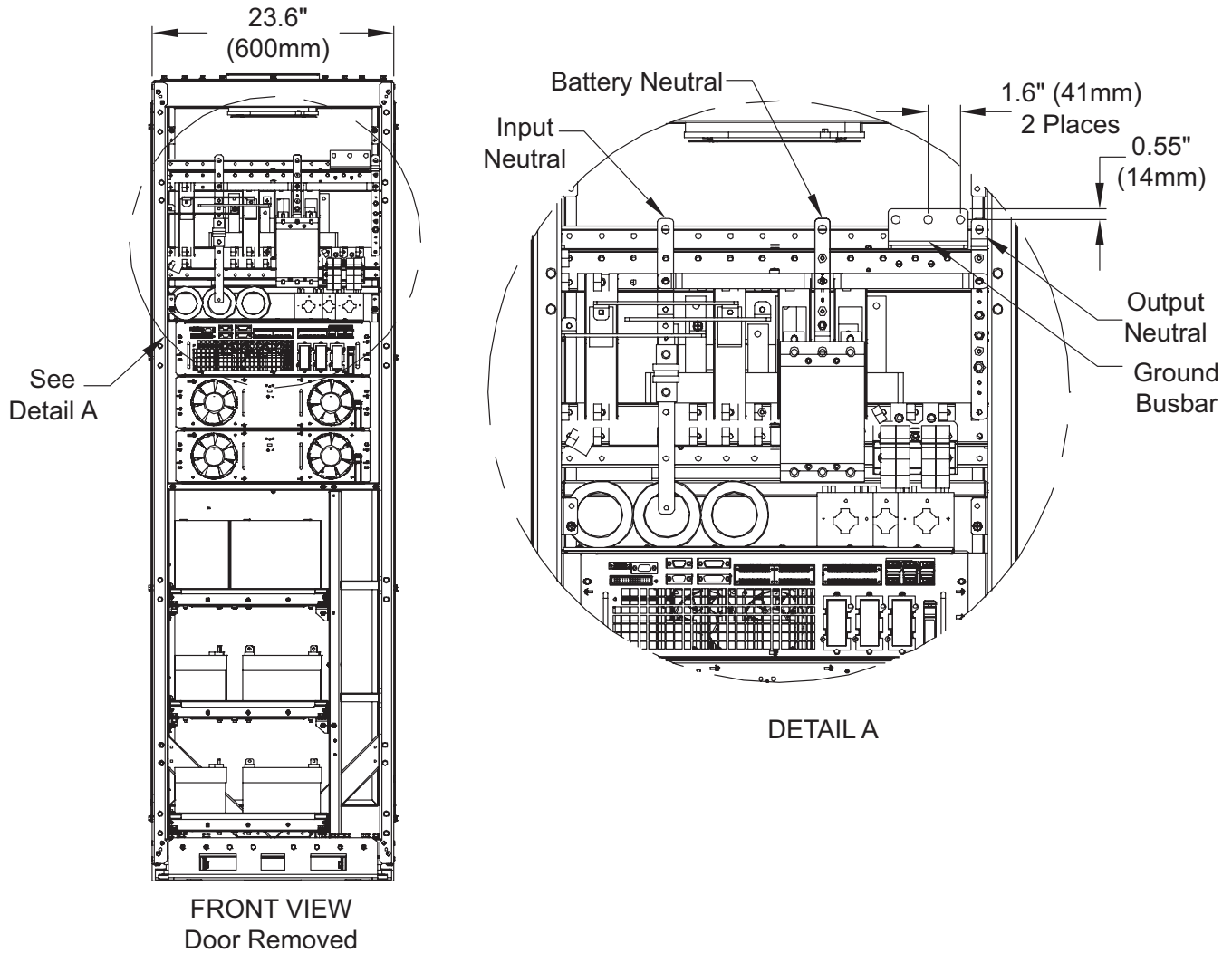

3.2.9 Protective Devices

For safety, it is necessary to install circuit breakers in the input AC supply external to the UPS system. Given that every installation has its own characteristics, this section provides guidelines for qualified installation engineers with knowledge of operating practices, regulatory standards and the equipment to be installed.

UPS Rectifier and Bypass Input Supply

Protection from excessive overcurrents and short circuits in power supply input

External overcurrent protection for the AC output circuit is to be provided. See **7.3 - UPS Electrical Characteristics** and **Table 20** for recommended breaker ratings.

Overcurrent protection for the battery circuit must be provided by the customer when using an optional External Battery Cabinet.

- **Dual Input Single Source**

When wiring the UPS with dual inputs but with a single input source, the Rectifier input and the Bypass input must be protected separately. Size the breakers according to the input currents shown in **Tables 15** through **18**.



NOTE

*For single or dual input, a 120V shunt trip coil(s) is required when a breaker is supplied by the customer. See **Figures 8** and **9** for details.*

System Output

When using an external distribution panel for load distribution, the output neutral and input neutral must be separated at the input to the UPS.

3.2.10 Cabling Procedure



WARNING

All operations described in this section must be performed by properly trained and qualified electricians or technical personnel. If any difficulties are encountered, contact Vertiv™. See the back page of this manual for contact information.



AVERTISSEMENT

Toutes les opérations décrites dans cette section ne doivent être effectuées que par des électriciens ou des techniciens professionnels dûment formés et qualifiés. En cas de difficultés, communiquez avec Vertiv. Pour obtenir les renseignements de contact, consultez la dernière page de ce manuel.



NOTE

Hydraulic pressure pliers, combinative tools and piston ring pliers should be used to connect AC wiring.

Once the equipment has been positioned and secured for operation, and the battery and ground lugs have been connected (see **3.2.6 - Cable Connections**), connect the power cables as described below. (Study the reference drawing in **4.0 - Installation Drawings**.)

1. Verify that all incoming high and low voltage power circuits are de-energized and locked out or tagged out before installing cables or making any electrical connections.
2. Remove the front I/O panel to gain easier access to the connections busbars.
3. Connect the facility ground and ancillary ground bus cables to the copper ground busbar located in the middle of the Liebert® EXM behind the output connections. All cabinets in the UPS system must be connected to the user's ground connection.



NOTE

The grounding and neutral bonding arrangement must comply with the National Electrical Code and all applicable local codes.

4. Identify and make power connections with incoming cables according to **Steps 5** through **8**.

Common Input Connections

5. For common bypass and main inputs, connect the AC input supply cables to the UPS input terminals (A2-B2-C2-N1) and tighten the connections to 240lb-in. (27N-m) (M10 Bolt). Ensure correct phase rotation.



NOTE

For common bypass and main inputs, the AC input cables must be connected to the bypass terminal (A2-B2-C2-N1) but not the main input terminal (A2-B2-C2).

Split Bypass Connections

6. If a split bypass configuration is used, connect the AC input supply cables to the rectifier input terminals (A1-B1-C1-N1) and the AC bypass supply cables to the bypass input terminals (A2-B2-C2-N1) and tighten the connections to 240lb-in. (27N-m) (M10 Bolt). Ensure correct phase rotation.



NOTE

For split bypass operation, ensure that the busbars between bypass and rectifier inputs are removed. The neutral line of the bypass input must be connected to that of the rectifier input.

Output System Connections—Ensure Correct Phase Rotation

7. Connect the system output cables between the UPS output busbars (A-B-C-N terminals) and the critical load and tighten the connections to 240lb-in. (27N-m) (M10 bolt).



WARNING

Risk of electrical shock. Can cause injury or death.

If the load equipment will not be ready to accept power on the arrival of the commissioning engineer, ensure that the system output cables are safely isolated at their termination.



AVERTISSEMENT

Risque de décharge électrique pouvant causer des blessures graves, voire mortelles.

Si les équipements branchés ne sont pas prêts à être alimentés à l'arrivée de l'ingénieur de mise en service, assurez-vous que les bornes des câbles de sortie du système soient isolées de façon sécuritaire.

Observe the battery cable polarity. Be sure that the battery connections, if any, are made with the correct polarity.

8. Refit all protective covers removed for cable installation.

3.3 Control Cables Details

3.3.1 Static Bypass Assembly Features

Based on your site's specific needs, the UPS may require auxiliary connections to manage the battery system (external battery circuit breaker, battery temperature sensor), communicate with a personal computer or provide alarm signaling to external devices or for Remote Emergency Power Off (REPO). Terminations for these functions are located at the front of the static bypass assembly. The main features are:

- Input and output dry contacts signal (one pair of contacts of relay)
- Emergency Power Off control (EPO)
- Environmental parameter input interface
- User communication (for data setting and user background monitor)
- Liebert IntelliSlot interface
- Temperature detect interface

Figure 14 Static bypass assembly connections to display cabinet and options

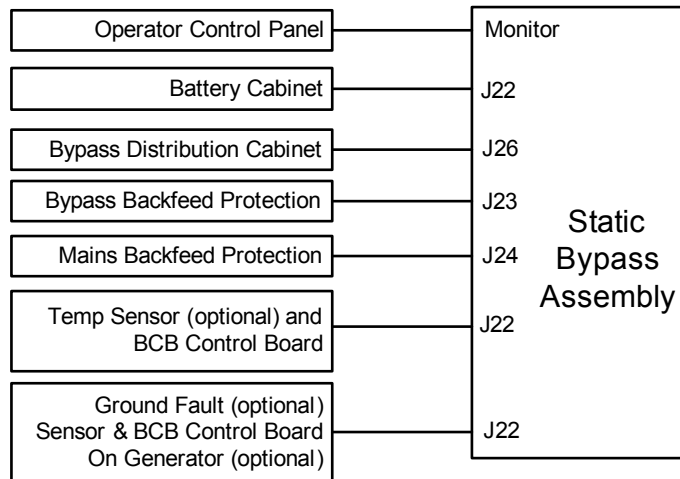
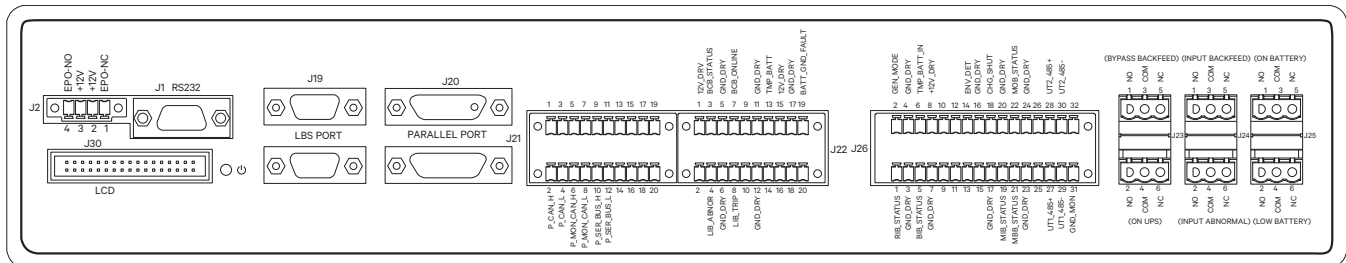

Figure 15 Auxiliary terminal block detail (static switch assembly front panel)



3.4 Dry Contacts

The UPS provides input dry contacts and output dry contacts on the Auxiliary Terminal Block (Dry Contact Terminal Block).

3.4.1 Input Dry Contacts

External input dry contacts are connected via the Dry Contact Terminal Block. Dry contacts are available for environment detection, battery ground fault detection, etc.

The UPS accepts external signal from zero-voltage (dry) contacts connected through external dry contact terminals produced, and these terminals are on the static bypass assembly. Through software programming, these signals become active when these contacts connect to +12V to ground (in the most left side). The cables connected to the monitor board must be separated from power cables. Moreover, these cables should be double-insulated with a typical cross-section of 0.5 to 1mm² for a maximum connection length between 82 and 165ft. (25-50m). The Dry Contact Terminal Block has several input dry contacts.

Figure 16 Input dry contacts

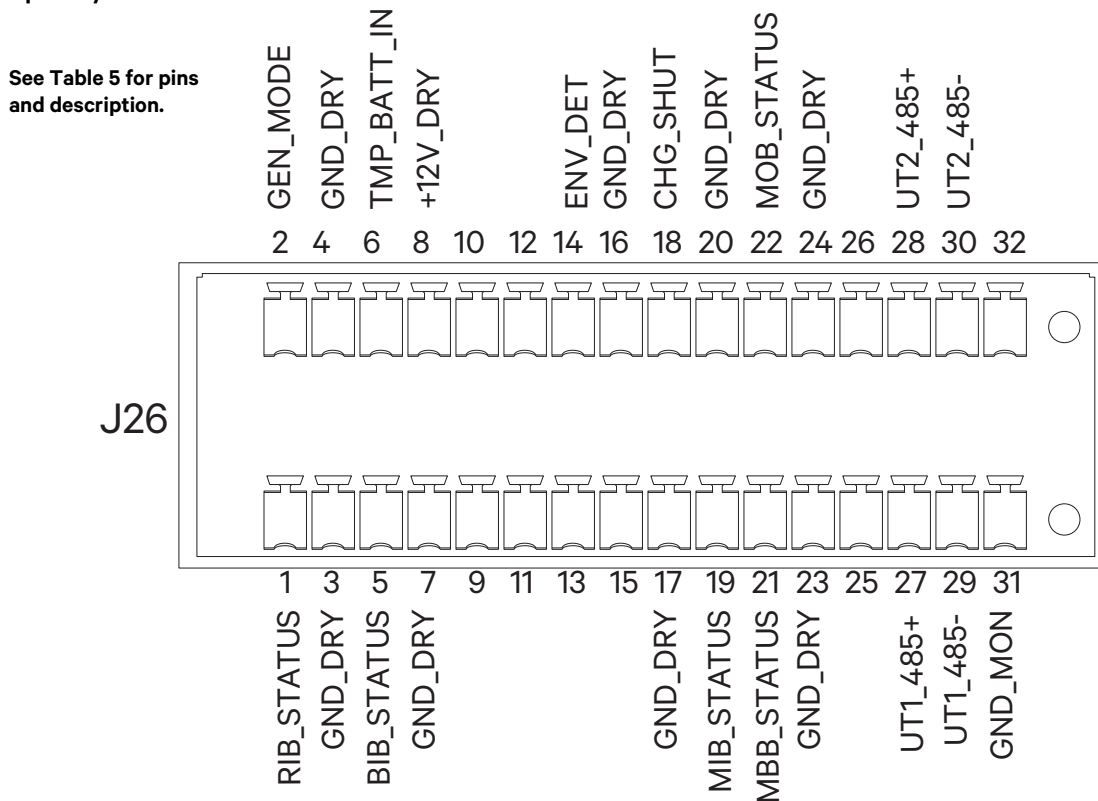

Table 5 Input dry contacts—J26

Pin	Name	Description
1	RIB_STATUS	Rectifier Input Breaker Status (Short for RIB Closed)
3	GND_DRY	Dry Ground
5	BIB_STATUS	Bypass Input Breaker Status (Short for BIB Closed)
7	GND_DRY	Dry Ground
9	LEGACY_MBB	Legacy Maintenance Bypass Breaker Status (Open for MBB Closed)
11	GND_DRY	Dry Ground
13	LEGACY_MIB	Legacy Maintenance Isolation Breaker Status (Short for MIB Closed)
15	GND_DRY	Dry Ground
17	GND_DRY	Dry Ground
19	MIB_STATUS	Maintenance Isolation Breaker Status (Open for MIB Closed)
21	MBB_STATUS	Maintenance Bypass Breaker Status (Short for MBB Closed)
23	GND_DRY	Dry Ground
25	—	N/A
27	UT1_485+	RS485+ Channel #1
29	UT1_485-	RS485+ Channel #1
31	GND_MON	Monitor Ground
2	GEN_MODE	Generator Mode (N.O.)
4	GND_DRY	Dry Ground
6	TMP_BATT_IN	Battery Temperature
8	+12V_DRY	+12V Power
10	—	N/A
12	GND_DRY	Dry Ground
14	ENV_DET	Environment Room Temperature (N.O.)
16	GND_DRY	Dry Ground
18	CHG_SHUT	Charger Shutdown (N.O.)
20	GND_DRY	Dry Ground
22	MOB_STATUS	Module Output Breaker Status (Open for MOB Closed)
24	GND_DRY	Dry Ground
26	—	N/A
28	UT2_485+	RS485+ Channel #2
30	UT2_485-	RS485+ Channel #2
32	—	N/A

3.4.2 Output Dry Contacts

The Dry Contact Terminal Block has three output dry contact relays (see **Figure 17** and **Table 6**).

Figure 17 Output dry contacts and EPO wiring

See Table 6 for pins and description.

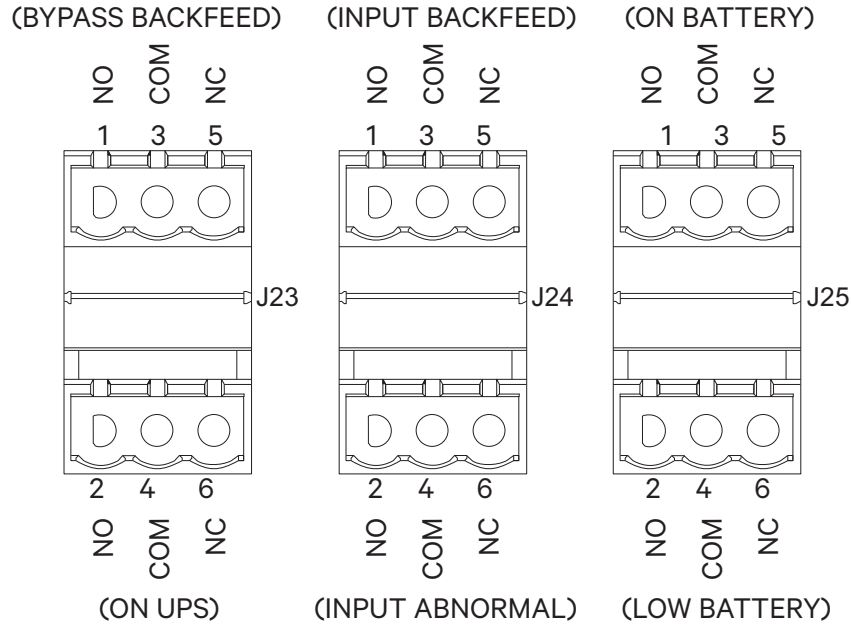

Table 6 Output dry contact relays

Port	Pin	Description
J23	1	Bypass Backfeed NO
	3	Bypass Backfeed COM
	5	Bypass Backfeed NC
J23	2	On UPS NO
	4	On UPS COM
	6	On UPS NC
J24	1	Input Backfeed NO
	3	Input Backfeed COM
	5	Input Backfeed NC
J24	2	Input Abnormal NO
	4	Input Abnormal COM
	6	Input Abnormal NC
J25	1	On Battery NO
	3	On Battery COM
	5	On Battery NC
J25	2	Low Battery NC
	4	Low Battery COM
	6	Low Battery NC



NOTE

All auxiliary cables of terminal must be double-insulated. Wire should be 20-16AWG stranded for maximum runs between 80 and 200 feet (25-60m), respectively.

3.4.3 Liebert BDC Interface

The Liebert BDC interface is on the Dry Contact Terminal Block at J26. Refer to **Figure 16** for circuit details. For further information, refer to the Liebert EXM BDC manual, SL-25653, available at Vertiv's Web site.



NOTE

All auxiliary cables of terminal must be double-insulated. Wire should be 20-16AWG stranded for maximum runs between 80 and 200 feet (25-60m), respectively.



NOTE

Refer to SL-25653, the Liebert® EXM Bypass Distribution Cabinet manual for the Liebert BDC wiring.

3.4.4 Battery Cabinet Interface Connectors

The battery cabinet interface is on the Auxiliary Terminal Block at J22. Refer to **Figure 18** for circuit details.

Figure 18 Battery cabinet interface—J22

See Table 7 for pins and description.

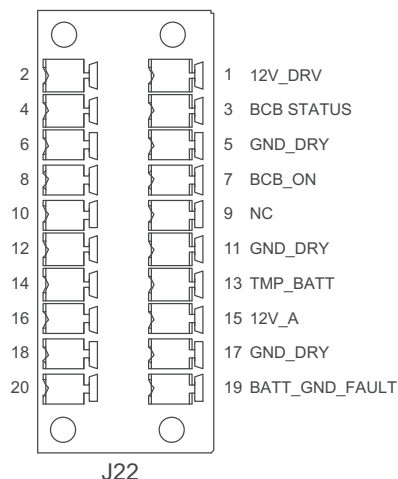

Table 7 Battery cabinet interface—J22

Pin	Name	Description
1	12V_DRV	BCB driver signal
3	BCB STATUS	BCB state signal
5	GND_DRY	Dry ground
7	BCB_ON	BCB on line signal
9	NC	NC
11	GND_DRY	Dry ground
13	TMP_BATT	External Battery temperature
15	12V_A	Power
17	GND_DRY	Dry ground
19	BATT_GND_FAULT	Battery ground fault signal



NOTE

All auxiliary cables of terminal must be double-insulated. Wire should be 20-16AWG stranded for maximum runs between 80 and 200 feet (25-60m), respectively.

3.4.5 EPO Input—Optional

NOTICE

Risk of exceeding internal voltage limits. Can cause equipment damage.

Do not apply more than 12V to the Emergency Power Off (EPO) input. Exceeding 12V on this input can damage the Liebert EXM's internal circuitry and control boards. Exceeding 12V will also put the Liebert EXM in an EPO state, and the unit will not reset, making it non-functional.

The UPS has an Emergency Power Off (EPO) function operated by a button on the control panel or by a remote contact provided by the user. The EPO button is under a hinged, clear plastic shield.

The J2 connector, in **Figure 19**, is the remote EPO input interface. The EPO has NO/NC contacts that become active when shorting terminals J2: 3 and 4 or open terminal connection J2:2 and 1.

If an external Emergency Stop capability is required, it is connected at terminals J2: 1 and 2 and at J2: 3 and 4 on the monitor board. It also is connected to the Normally Open or Normally Closed remote stop switch between these two terminals using shielded cable (see **Figure 19** and **Table 8**). If this function is not used, terminals J2:3 and 4 must be opened and J2:1 and 2 must be closed.

Figure 19 EPO wiring and signal names for J2

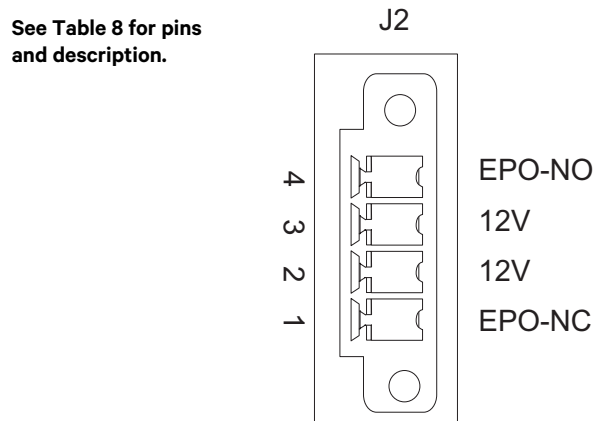

Table 8 EPO input contact relays—J2

Pin	Name	Description
1	EPO-NC	EPO activated when opened to Pin 2
2	+ 12V	—
3	+ 12V	—
4	EPO-NO	EPO activated when shorted to Pin 3



NOTE

The Emergency Stop action within the UPS shuts down the rectifier, inverter and static bypass. It does not internally disconnect the input power supply. To disconnect ALL power to the UPS, open the upstream feeder breaker(s) after the remote EPO is activated.



NOTE

Normally Closed EPO – J2: 1,2, these terminals are supplied factory-linked on the Bypass Module on the UPS and must remain installed if using NO contacts.



NOTE

All auxiliary cables of terminal must be double-insulated. Wire should be 20-16AWG stranded for maximum runs between 80 and 200 feet (25-60m), respectively.

Figure 20 Single UPS Remote Emergency Power Off

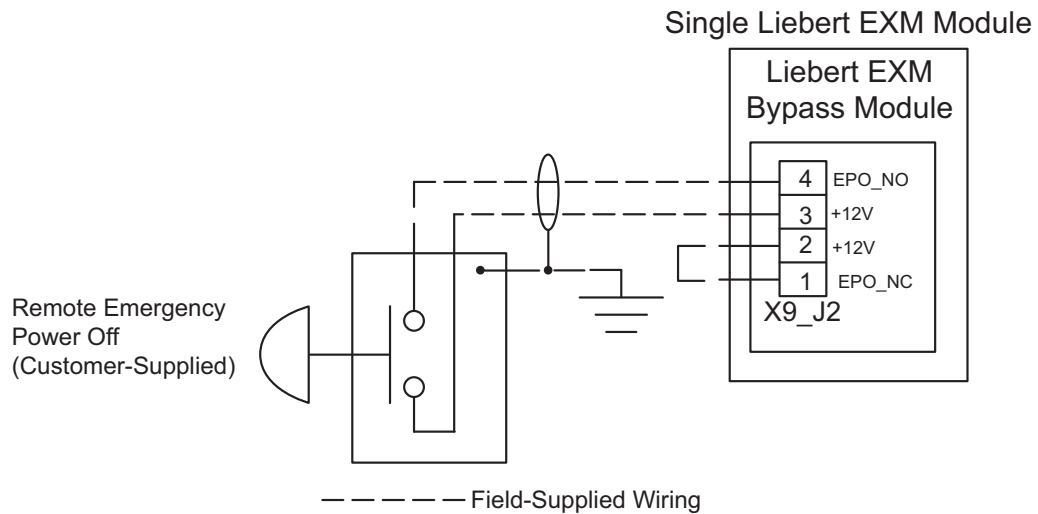

3.5 Parallel Cable Connections

Figure 21 Parallel cable wiring diagram

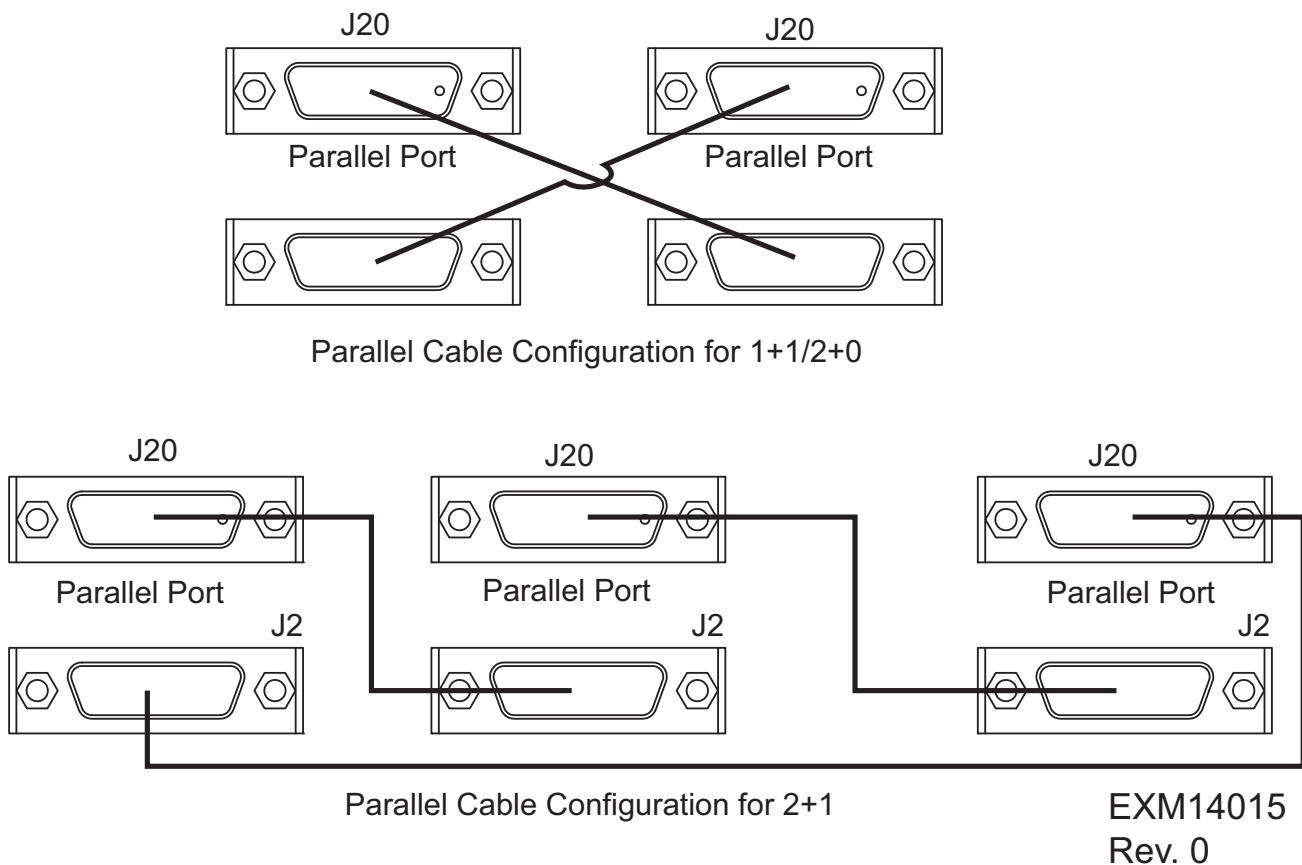

4.0 INSTALLATION DRAWINGS

The diagrams in this section illustrate the key mechanical and electrical characteristics of the Liebert® EXM UPS System cabinets (UPS, Liebert BDC and battery).

Figure 22 UPS dimensions

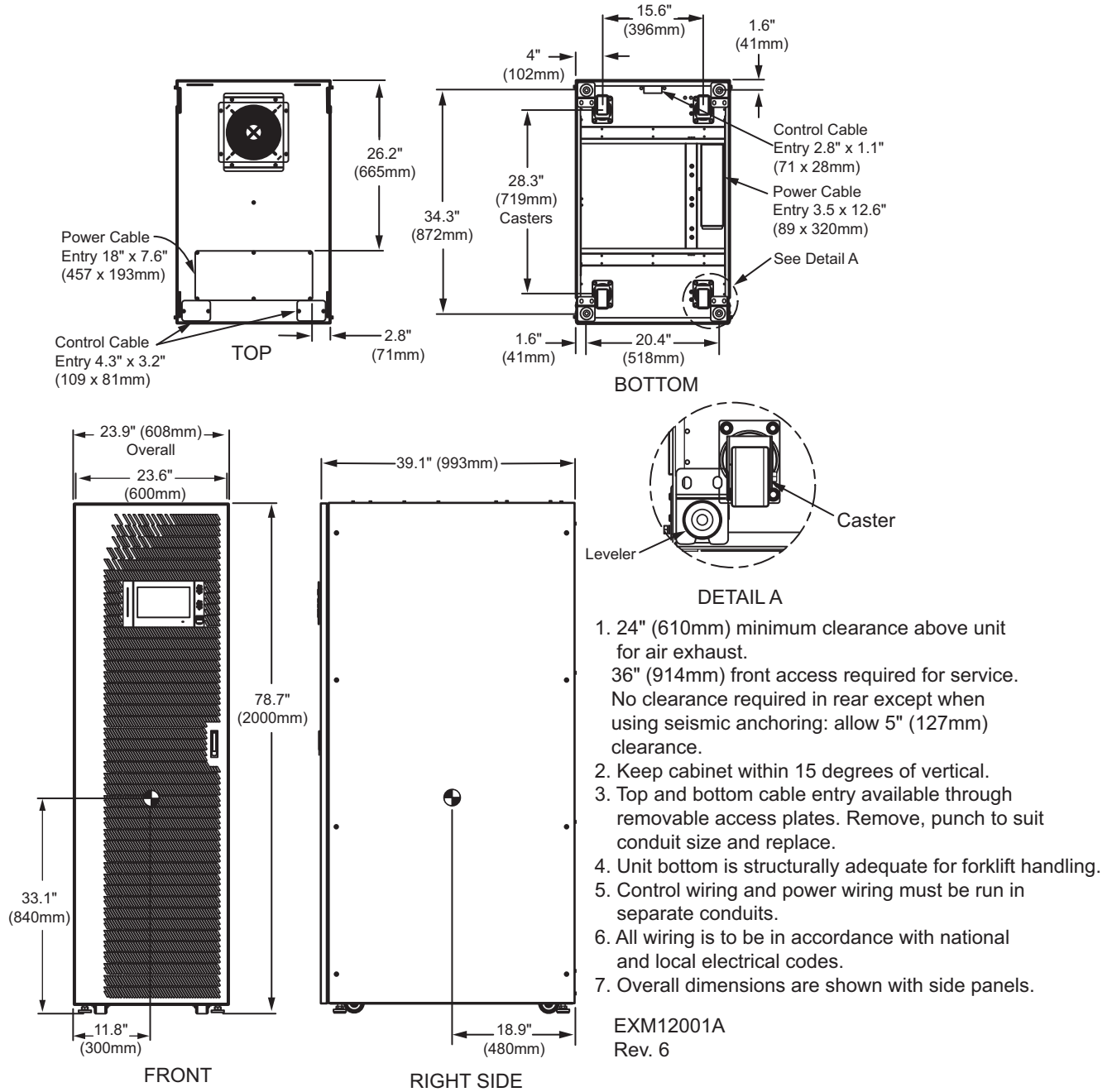

Figure 23 UPS main components—Typical 10-40kVA unit

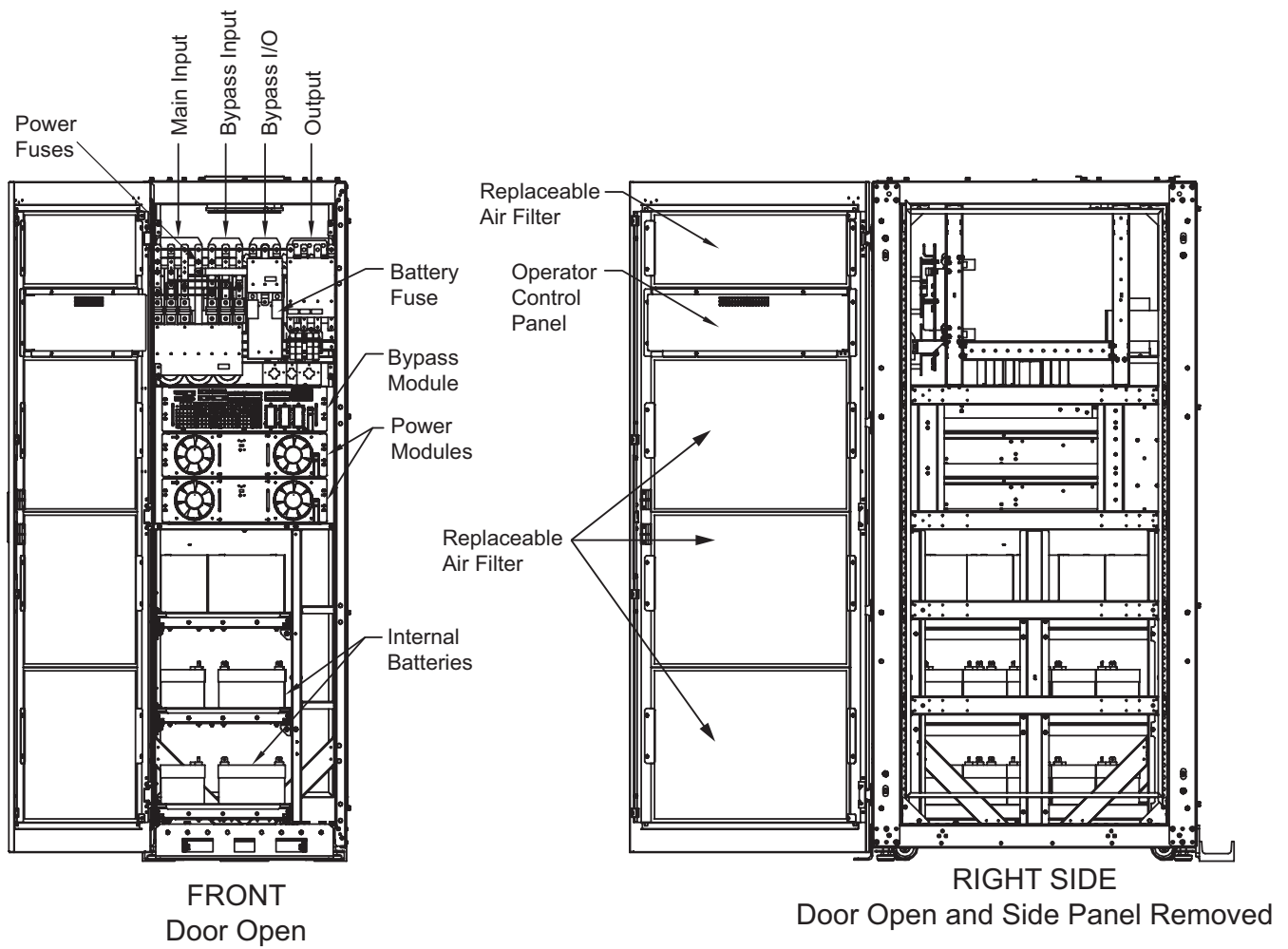
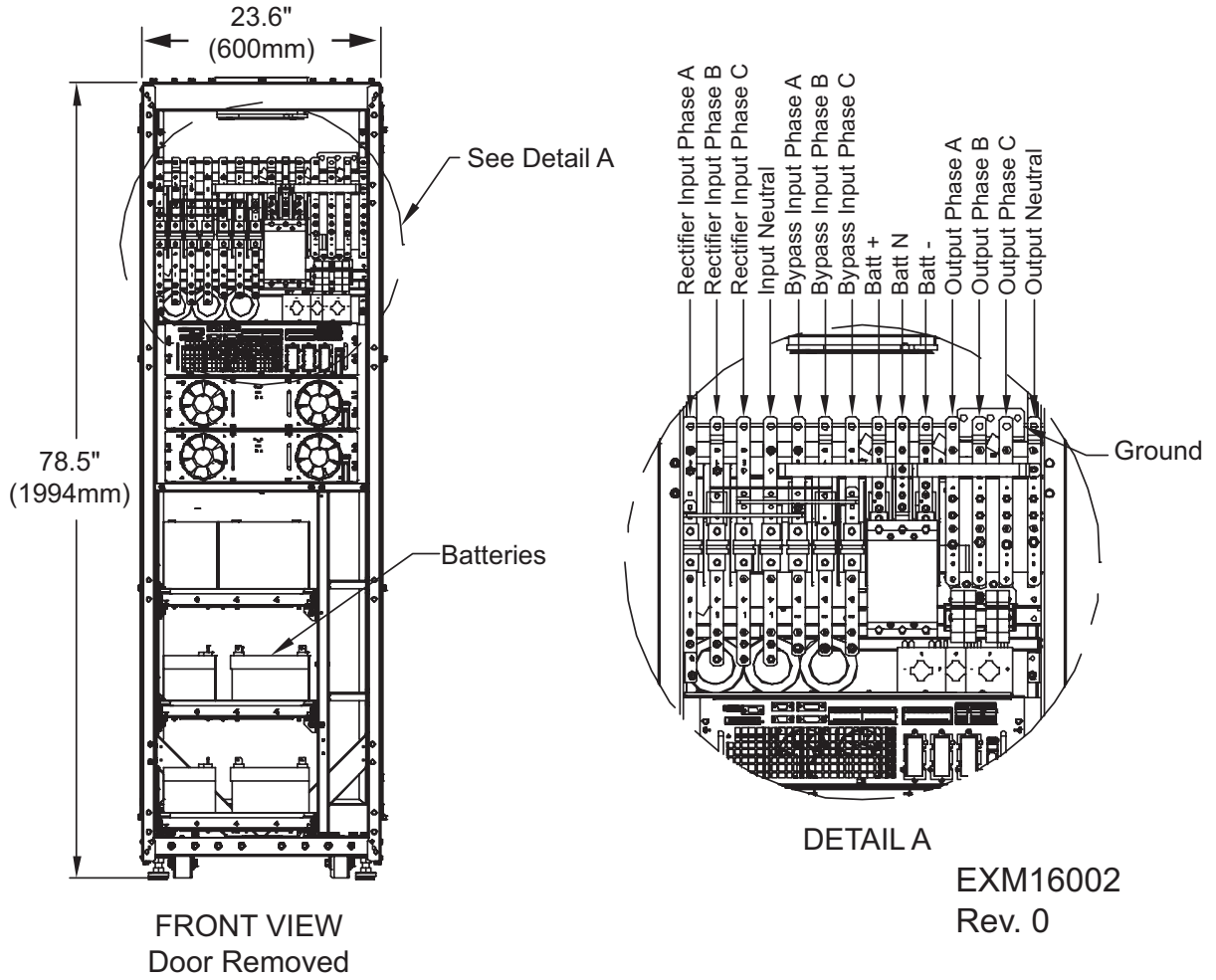

Figure 24 UPS cable connections—10-40kVA frames



5.0 OPTION INSTALLATION

5.1 Liebert IntelliSlot Communication

The Liebert® EXM has three Liebert IntelliSlot ports to allow field-installation of optional communication cards. Liebert IntelliSlot cards communicate via Liebert’s proprietary Velocity protocol to cards that translate the information into such protocols as SNMP and Modbus. Other cards provide dry contact signals for external signaling of operating status.

The Liebert IntelliSlot communication ports may be installed or removed while the Liebert® EXM is operating.

5.2 Liebert IntelliSlot Web Card—SNMP/HTTP Network Interface Card

This network interface card provides all real-time data and status information as SNMPv1 traps for connection to a 10/100-baseT Ethernet connection. The same card also will transmit the same status information and all measured parameters for display via a Web browser. The Liebert IntelliSlot bays are on the right side of the control module and labeled as IntelliSlot1, IntelliSlot2 and IntelliSlot3.

Table 9 Liebert® EXM communication options

Port Type and Location	Labeled ID Name of Port	Monitoring Devices Supported
Left Liebert IntelliSlot	IntelliSlot 1	IS-Relay
		IS-Unity-DP
		IS-Unity-LIFE
		IS-485EXI
Center Liebert IntelliSlot	IntelliSlot 2	IS-Relay
		IS-Unity-DP
		IS-Unity-LIFE
		IS-485EXI
Right Liebert IntelliSlot	IntelliSlot 3	IS-Relay
		IS-Unity-DP
		IS-Unity-LIFE
		IS-485EXI

5.2.1 Liebert IntelliSlot Unity Cards—IS-UNITY-LIFE, IS-UNITY-S, IS-UNITY-DP

- **IS-UNITY-LIFE:** This standard card is used for communication between the Liebert® EXM and Vertiv’s *Trellis* NMS and LIFE services.
- **IS-UNITY-DP:** This card can be used instead of the standard card if communication to two third-party platforms is required. Third-party platforms include SNMP and 485 (Modbus/BACnet) protocols. This card would still be used for communication between the Liebert EXM and Vertiv’s *Trellis* NMS and LIFE Services. All communication protocols are active simultaneously.
- **Liebert IntelliSlot Dry Contact Card (IS-RELAY):** Provides dry contact alarm information, including: On Battery, On Bypass, Low Battery, Summary Alarm, UPS Fault and On UPS signals for communication to a remote monitoring system.
- **IS-485EXI:** The Liebert IntelliSlot 485 EXI Card provides connection to a Liebert SiteLink-E allowing Liebert SiteScan® Web 4.0 monitoring and control of your Liebert equipment.

5.3 Liebert IntelliSlot Web Card—Optional

An optional Web card is available that provides remote access to the UPS. A wide variety of status and summary information is available through an Ethernet connection.

Figure 25 Liebert IntelliSlot Web card display

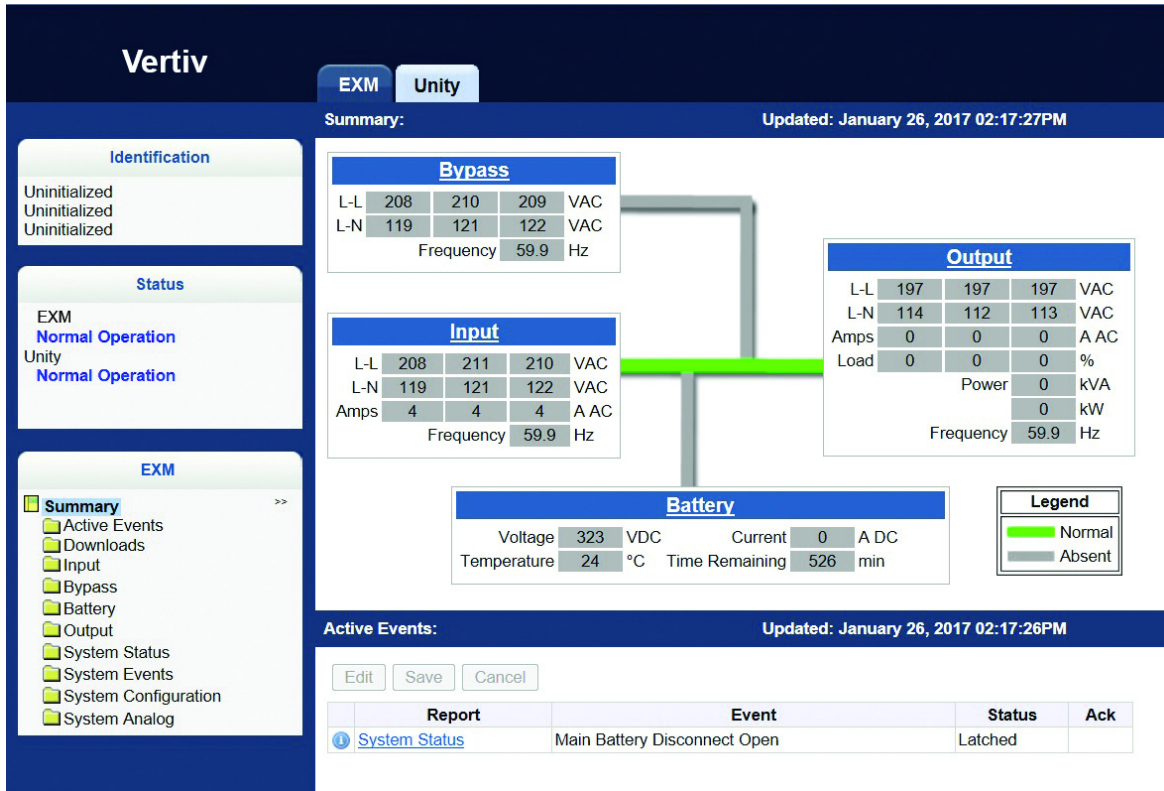

5.4 Liebert IntelliSlot Relay Card

The Liebert IntelliSlot Relay card (IS-RELAY) provides voltage-free contact closures for remote monitoring of alarm conditions.

Delivering **On Battery, On Bypass, Low Battery, Summary Alarm, UPS Fault** and **On UPS** signals, the easy-to-install card integrates with AS/400 computers (additional cable required) and other relay contact monitoring systems.

The relay card is rated for 24 VAC/DC at 1A. and supported in any of the three Liebert IntelliSlot bays on the Liebert® EXM.

5.4.1 Liebert IntelliSlot Relay Card Pin Configuration

The card has two terminals blocks, TB1 (green, numbered 1-9) and TB2 (black, 10-18), as shown in **Figure 26**.

Figure 26 Pin location and numbering

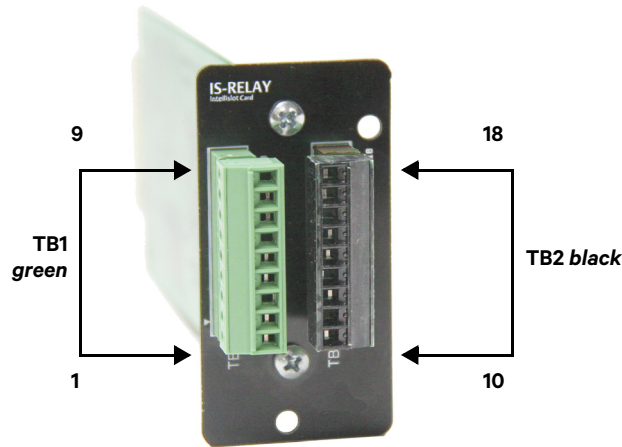

Refer to your Liebert product user manual for the pin configuration for the terminal blocks.

Table 10 Relay card pin configuration

Pin	Function	Operation
1	Common - Low Battery	
2	Low Battery	Closed if Low Battery point occurs.
3	Low Battery	Closed if battery is OK
4	Common - UPS Fault	
5	UPS Fault	Closed if UPS fault occurs
6	UPS Fault	Closed if no UPS failure
7	Common - On Battery	
8	On Battery	Closed if On Battery power (Utility failure)
9	On Battery	Closed if not On Battery power (Utility OK)
10	Not Used	
11	Not Used	
12	Not Used	
13	Summary Alarm*	Closed if no alarm conditions are present
14	Summary Alarm*	Closed if Summary Alarm occurs
15	Common - Summary Alarm	
16	On UPS	Closed if On UPS (inverter) power
17	On Bypass	Closed if On Bypass
18	Common - On Bypass	

5.4.2 Liebert IntelliSlot Relay Card Jumper Setup

The Liebert IntelliSlot Relay Card has five jumpers, P3 through P7, as shown in **Figure 27**. Each jumper connects two pins.

Figure 27 Jumper location and numbering

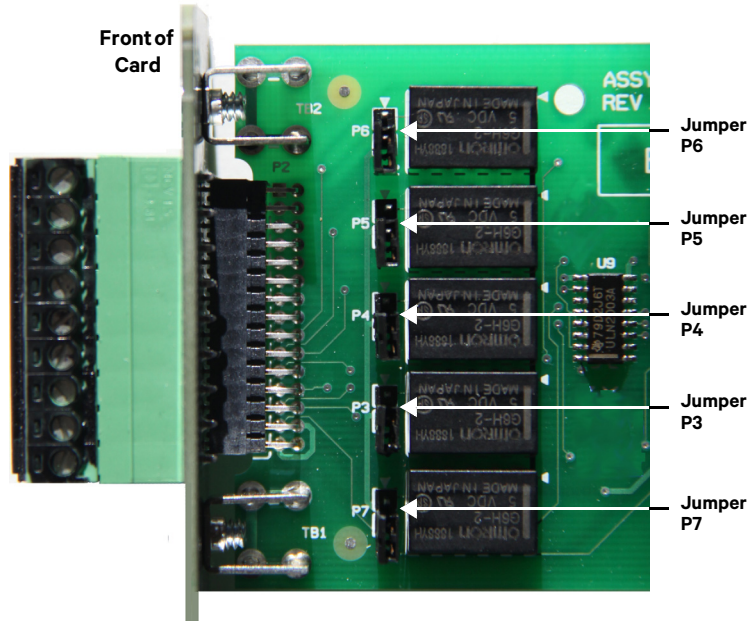

By default, all five jumpers have shunts installed. The two pins are shunted together to provide the functions shown in **Table 11**, allowing relay commons to be tied together.

The jumpers should be removed if there is any external voltage source that may intentionally or inadvertently be connected to the relay.

Removing the shunt from any two pins breaks the connection between the relay commons so they are not tied together.

Table 11 Jumper connections

Jumper	Relay
P6	On Battery
P5	UPS Fault
P4	Low Battery
P3	On Bypass
P7	Summary Alarm



NOTE

Refer to the Liebert IntelliSlot Relay Card manual, SL-23211 for additional details. the document is available at the Vertiv Web site, www.vertiv.com

6.0 OPERATION

WARNING

Risk of electrical shock. Can cause personal injury or death. This UPS has several circuits that are energized with high DC as well as AC voltages. Check for voltage with both AC and DC voltmeters before working within the UPS. Check for voltage with both AC and DC voltmeters before making contact.

Only properly trained and qualified personnel wearing appropriate safety headgear, gloves, shoes and glasses should be involved in installing the UPS or preparing the UPS for installation. When performing maintenance with any part of the equipment under power, service personnel and test equipment should be standing on rubber mats.

AVERTISSEMENT

Risque de décharge électrique pouvant causer des blessures graves, voire mortelles. Ce système ASC comporte plusieurs circuits à haute tension c.a et c.c. Vérifiez les tensions au moyen de voltmètres c.a. et c.c. avant d'utiliser le système ASC. Vérifiez les tensions avec des voltmètres c.a. et c.c. avant d'établir tout contact.

Seuls des employés qualifiés et dûment formés portant un casque, des gants, des chaussures et des lunettes de sécurité adéquats doivent se charger d'installer le système ASC ou de le préparer pour l'installation. Les responsables de l'entretien et l'équipement d'essai doivent reposer sur des tapis de caoutchouc lors de toute intervention sur une pièce d'équipement sous tension.

The Liebert® EXM operates in the modes shown in **6.4 - Liebert® EXM Operating Modes**. This section describes various kinds of operating procedures under each operating mode, including transfer between operating modes, UPS setting and procedures for turning on/off inverter. As shown in SL-25656, the Liebert® EXM Battery Cabinet manual, the AC utility source is supplied through the input breaker, and the rectifier converts the alternating current into DC power. The inverter converts the AC power from the utility—or DC power from an optional External Battery Cabinet—into AC power for the load. The batteries power the load through the inverter in the event of a power failure. The utility source can also power the load through the static bypass. If maintenance or repair of the UPS is necessary, the load can be switched without interruption in service using the optional Liebert MBC.

6.1 Touchscreen Control Panel

The Liebert® EXM's Touchscreen Control Panel is active whenever the UPS has input power. The touchscreen LCD on the front of the UPS permits:

- Logging in to the system
- Customizing the user interface
- Checking the status of the UPS and its external batteries, including all measured parameters, events and alarms
- Determining when users logged in and out
- Silencing alarms
- Turning the UPS On and Off
- Resetting faults
- Enabling Energy Saving Mode

Scan the QR code at right to obtain a copy of the Touchscreen Control Panel manual.



6.2 Access Level Log-In

The Touchscreen Control Panel provides security by limiting the authority to change how the UPS operates. Each of the four access levels offers different authority:

- Observer—Viewing permission only, can choose graphic or text display, view logs and silence alarms; no PIN required
- Operator—Permission to start and shut down the UPS, edit the display layout, test the battery, reset faults, enable or disable Eco Mode operation, enable equalize battery charging and acknowledge alarms; PIN required
- Administrator—All functions of Operator plus permission to change PIN's for Operator and Administrator level, configure the Status Gauge, set energy saving mode and change network communication protocols; PIN required
- Service—All functions of Administrator plus permission to alter system configuration and change Service PIN; PIN required.

6.3 Default PIN's

Vertiv Services sets PIN's when setting up the UPS. These default PIN's may be changed by those with Administrator or Service access (see above). Default PIN's are:

- Operator: 1234
- Administrator: 2345

NOTICE

Risk of unauthorized changes to operational settings. Can cause equipment damage.

The default PIN numbers should be changed immediately to prevent unauthorized personnel from changing UPS operation or even shutting down the UPS. Refer to the Touchscreen Control Panel, SL-26200, available at Vertiv's Web site, www.vertiv.com for details.

6.4 Liebert® EXM Operating Modes

The UPS is designed to operate as an on-line, double-conversion, reverse-transfer system in the following modes:

- Load on Inverter Mode
- Load on Battery Mode
- Auto-Restart Mode
- ECO Mode
- Load on Bypass Mode
- Module Redundancy Mode
- Frequency Converter Mode
- Power Conditioner Mode
- Maintenance Mode (Manual Bypass)
- Sleep Mode
- Paralleling Mode
- Output Voltage Adjustment Mode
- Generator Mode



NOTE

1. The user controls and indicators referred to in these procedures are detailed in the UPS control panel manual, SL-26200, available at Vertiv's Web site, www.vertiv.com
2. The audible alarm may sound at various points during these procedures. It can be canceled at any time by pressing the menu button (under any login), pressing Alarms and then pressing Alarms.



NOTE

This unit refers to some modes and conditions that are set or adjusted using proprietary service software. To take advantage of all the available features for the Liebert EXM, the unit must be commissioned by a Vertiv-authorized engineer.

Load on Inverter Mode

Operating in Mode, the Liebert EXM's rectifier derives power from a utility AC source and supplies regulated DC power to the inverter, which regenerates precise AC power to supply the connected equipment. The rectifier also uses the utility source power to charge the batteries.

Module Redundancy Mode

When the Liebert® EXM is in module redundancy mode, the load percentage is calculated using the available power module capacity or nameplate rating capacity, whichever capacity is lower.

Module redundancy mode can be set at the factory or by the user. A maximum of one module can be set for redundancy. Availability of this feature depends on module capacity of the frame. Refer to the UPS control manual, SL-26200, for instructions on setting this feature. The manual is available at Vertiv's Web site,

www.vertiv.com

Example 1

- Two 20kVA power modules installed
- Nameplate rating capacity = 20kVA
- One power module in redundant mode
- Configured capacity = 20kVA
- Load = 20kVA

Load percentage will be calculated based on nameplate rating capacity = 20kVA capacity. In the event of a single power module fault, the system will signal a Loss of Redundancy Alarm and a Power Hardware Mismatch and continue in double-conversion mode and provide up to 20kVA capacity.

Example 2

- Two 20kVA power modules installed
- Nameplate rating capacity = 40kVA
- One power module in redundant mode
- Configured capacity = 20kVA
- Load = 20kVA

Load percentage will be calculated based on available power module capacity = 40kVA capacity. In the event of a single power module fault, the system will signal a Loss of Redundancy Alarm and a Power Hardware Mismatch Alarm. The system will continue in double-conversion mode and provide up to 20kVA capacity.

Example 3

- Two 20kVA power modules installed
- Nameplate rating capacity = 40kVA
- One power module in redundant mode
- Configured capacity = 20kVA
- Load = 30kVA

Load percentage will be calculated based on available power module capacity = Loss of Redundancy Alarm. The system will continue in double-conversion mode and provide up to 40kVA capacity.

Frequency Converter Mode

When the the Liebert EXM to is set to Frequency Converter Mode permits configuring the unit for 50Hz output, bypass is disabled and battery is optional to support load. This mode can only be enabled at the factory or by Vertiv Services.

Power Conditioner Mode

When EXM is set to Power Conditioner Mode, the battery is disabled in this mode. This mode can only be enabled at the factory or by Vertiv Services.

Load on Battery Mode—Requires Optional External Battery Cabinet

When utility AC power fails, the Liebert® EXM protects the critical load by instantaneously channeling battery power from optional External Battery Cabinets to the inverter, which continues supporting the critical load without interruption. When utility power returns and is within acceptable limits, the Liebert® EXM automatically shifts back to Load on Inverter Mode, with the rectifier powering the critical load.

Auto-Restart Mode

The battery may become exhausted following an extended AC utility failure. The inverter shuts down when the battery reaches the End of Discharge voltage (EOD). The UPS may be programmed to “Auto Recovery after EOD” after a delay time if the AC utility recovers. This mode and any delay time may be programmed by the commissioning engineer.

Load on Bypass Mode

When the Liebert® EXM load is supplied by the bypass, the load is directly supported by utility power and is without battery backup protection.

The Liebert EXM's static transfer switch will shift the load from the inverter to the bypass without interruption in AC power if the inverter is synchronous with the bypass and any of the following occurs:

- inverter fails
- inverter overload capacity is exceeded
- inverter is manually turned Off by user



NOTE

If the inverter is asynchronous with the bypass, the static switch will transfer the load from the inverter to the bypass WITH interruption in AC power to the critical load. This interruption will be less than 15ms (in 50Hz), or less than 13.33ms (in 60Hz). This interruption time may be altered by modifying the Output transfer interrupt time setting.

ECO Mode (Single-Module UPS System Only)

When ECO mode is selected, the Liebert® EXM switches inverter power from the UPS input to the bypass input to save energy by improving UPS efficiency. In this mode, the bypass is the preferred source. If the bypass voltage or frequency becomes outside preset limits, the UPS load is transferred back to the inverter.

Maintenance Mode

For maintenance or repair, the Liebert® EXM may be operated in maintenance mode. To place the Liebert® EXM in maintenance mode, follow the instructions in **6.6 - Switching the UPS from Normal Operation to Maintenance Bypass**.



WARNING

Risk of arc flash and electric shock. Can cause equipment damage, injury and death
The UPS input and output must be protected with external overcurrent protection devices. In maintenance mode, the input and output busbars remain energized and present an electric shock hazard.



AVERTISSEMENT

Risque d'arc ou de décharge électrique pouvant entraîner des dommages matériels, des blessures et même la mort.

L'entrée et la sortie du système ASC doivent être protégées par des dispositifs de protection de surintensité externes. En mode d'entretien, les barres omnibus d'entrée et de sortie demeurent sous tension et présentent un risque de décharge électrique.

Output Voltage Adjustment

This feature allows a Liebert Customer Engineer to adjust the Liebert EXM's output voltage over a range of -5% to +5% of nominal. The output voltage adjustment can be used to compensate for any drop in line voltage that may occur when the UPS is a significant distance from the protected load. In addition, it can be used to optimize the UPS output voltage for loads that operate more efficiently at a voltage different from the nominal Liebert® EXM output voltage.

Generator Mode

The Liebert® EXM UPS can be set up for operation in Generator Mode by a Vertiv Services engineer. The setup requires connecting J26 Pin 2 to Pin 4. The battery charger is disabled in Generator Mode.

6.5 UPS Startup

The Liebert® EXM must be fully installed and commissioned before startup, and external power isolators must be closed. Once those general conditions are met, the UPS may be started.



WARNING

Risk of electrical shock and arc flash. Can cause property damage, injury and death.

During this procedure the output terminals will become live.

If any load equipment is connected to the UPS output terminals, please check with the load user and ascertain whether it is safe to apply power to the load. If the load is not ready to receive power, then ensure that it is safely isolated from the UPS output terminals.



AVERTISSEMENT

Risque d'arc ou de décharge électrique pouvant entraîner des dommages matériels, des blessures et même la mort.

Durant cette procédure, les bornes de sortie seront sous tension.

Si un équipement chargé est raccordé aux bornes de sortie du système ASC, veuillez vous informer auprès de l'utilisateur de la charge s'il est sécuritaire d'appliquer une alimentation à la charge. Si la charge n'est pas prête à recevoir une alimentation, alors assurez-vous qu'elle est isolée sécuritairement des bornes de sortie du système ASC.

NOTICE

Risk of improper startup when feeding a downstream transformer. Can cause damage to connected equipment.

If the UPS is supplying a downstream transformer not provided by Liebert, the UPS should be put on maintenance bypass to energize it to mitigate the risk of in-rush current.

6.5.1 Startup Procedure

To start the UPS from a fully powered-down condition:

1. Log in as Operator, Administrator or Service.
2. Ensure that the Liebert Power Module Assembly ready switches are latched (in Down position).
3. Close the external input circuit breaker and connect input power. The touchscreen activates.
4. The rectifier goes through its startup sequence and the bypass static switch is activated.
5. Close the external output circuit breaker.
6. Touch the OPERATE tab
7. Touch the *Inverter On* button. When asked to confirm, touch *On* again.

The power module run lights will start flashing green while the unit goes through the inverter startup sequence. After about a minute, the inverter will turn On, the static bypass will open and the power module run lights will be solid green.

8. Close the battery breaker.

6.5.2 Startup in Eco Mode

Eco Mode is available only on a single-module Liebert® EXM.

1. Log in as Operator, Administrator or Service.
2. Touch the OPERATE tab.
3. Touch Energy Saving Mode Activation *Setup*.
4. In the drop-down menu, touch *Enable*.
5. Touch *Save*.

The UPS load should now be supplied by the bypass with the inverter on standby. The status bar at the top of the screen will say *ENERGY SAVING MODE ACTIVE*.

6.5.3 Switching Between UPS Operation Modes

To switch from Load on Inverter Mode to Load on Bypass Mode

1. Log in as Operator, Administrator or Service.
2. Touch the OPERATE tab.
3. Touch *Inverter Off* button to switch to Load on Bypass Mode.
4. To continue, confirm turning Off the inverter when prompted.

NOTICE

Risk of power loss to connected load. Can cause damage to equipment.

The load equipment is not protected from normal supply aberrations, such as spikes, sags and failure, when the Liebert® EXM load is supplied by the bypass or maintenance bypass.

To Switch from Load on Bypass Mode to Load on Inverter Mode

1. Log in as Operator, Administrator or Service.
2. Touch the OPERATE tab.
3. Touch the *Inverter On* button.

To continue, confirm turning On the inverter when prompted.

6.6 Switching the UPS from Normal Operation to Maintenance Bypass

Follow the procedure below to transfer the load from the UPS inverter output to the Maintenance Bypass system.

NOTICE

Risk of loss of power to the connected load. Can cause equipment damage.

This procedure must be performed by properly trained and qualified personnel who are knowledgeable about the operation of this system. Failure to follow these instructions will result in loss of power and possible damage to critical equipment.

Before performing this operation, read any messages on the touchscreen to be sure that bypass supply is regular and the inverter is synchronous with it. If those conditions are not present, there is a risk of a short interruption in powering the load.

This procedure assumes that UPS is operating normally.

1. Log in as Operator, Administrator or Service.
2. Touch the OPERATE tab.
3. Touch the *Inverter Off* button.
4. To continue, confirm turning Off the inverter when prompted.



NOTE

Pressing Silence from the OPERATE tab cancels the audible alarm, but leaves the warning message displayed until the appropriate condition is rectified.

5. Open the Liebert MBC door to gain access to the bypass isolation breaker (BIB), maintenance bypass breaker (MBB) and maintenance isolation breaker (MIB).
6. When the lamp indicator on the MBC is illuminated, press and hold the adjacent push button and remove the key from the lock (KO).
7. Insert the key into the lock on the MBB and turn the key.
8. Close the MBB.
9. Verify the MBB is closed. Failure to close the MBB will interrupt power to the load.
10. Open the MIB.
11. Remove the key from the lock on the MIB. Insert the key into the lock (KO) and turn the key.
12. The UPS system is now isolated from the critical load.
13. For a single-input system, the bypass isolation breaker (BIB) remains closed; this allows power to remain present at the UPS input; refer to **Figure 28**.
14. For a single-source, dual-input system, the bypass isolation breaker (BIB) can be opened to further isolate the UPS from input power; refer to **Figure 29**.

WARNING

Risk of electrical shock and arc flash. Can cause property damage, injury and death.
Wait 5 minutes for the internal DC busbar capacitors to discharge before attempting to remove the internal protective barriers.

AVERTISSEMENT

Risque d'arc ou de décharge électrique pouvant entraîner des dommages matériels, des blessures et même la mort.
Attendez 5 minutes que les condensateurs de barre omnibus c.c. internes se déchargent avant d'essayer de retirer les barrières de protection internes.

WARNING

Risk of electrical shock and arc flash. Can cause property damage, injury and death.
Even with the UPS in maintenance bypass and Off, portions of the Liebert® EXM system are still energized. Service must be performed by properly trained and qualified personnel only.

AVERTISSEMENT

Risque d'arc ou de décharge électrique pouvant entraîner des dommages matériels, des blessures et même la mort.
Même lorsque le système ASC est en mode de dérivation d'entretien et hors tension, des parties du système EXM de Liebert demeurent sous tension. L'entretien ne doit être confié qu'à un personnel qualifié et dûment formé.

NOTICE

Risk of power loss to connected load. Can cause damage to equipment.
The load equipment is not protected from normal supply aberrations, such as spikes, sags and failure, when the Liebert® EXM load is supplied by the bypass or maintenance bypass.

Figure 28 One-line diagram, single-input UPS with 3-breaker maintenance bypass cabinet and panelboard

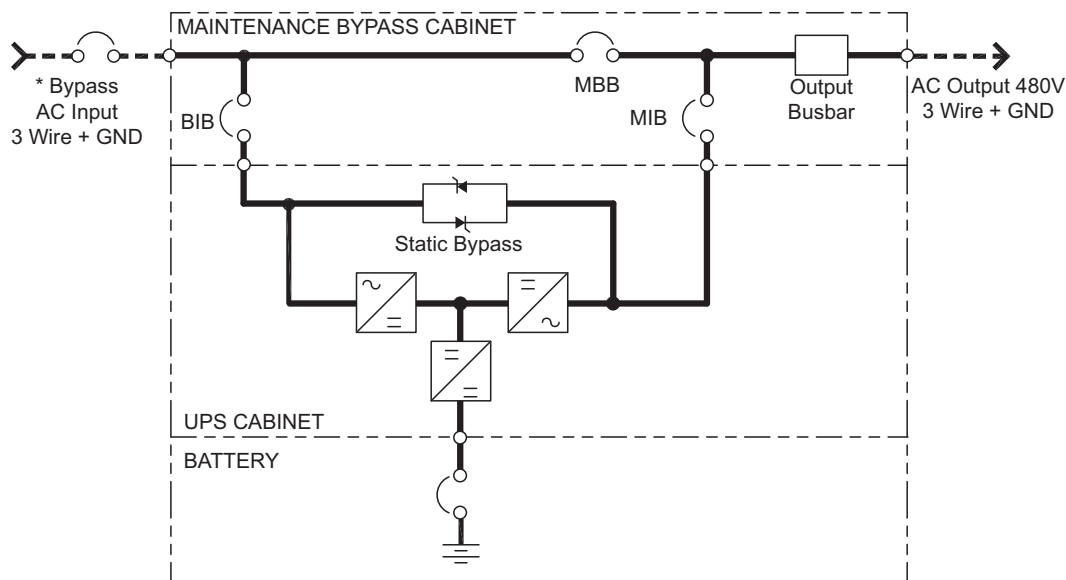

1. Install in accordance with national and local electrical codes.
 2. Input and bypass must share the same single source.
 3. UPS system input and output cables must be run in separate conduits.
 4. Control wiring must be run in separate conduits.
- BIB - Bypass Isolation Breaker
 - MBB - Maintenance Bypass Breaker
 - MIB - Maintenance Isolation Breaker
 - * External Overcurrent Protection By Others
 - Field-Supplied Wiring

6.7 Switching the UPS from Maintenance Bypass to Normal Operation

Follow the procedure below to transfer the load from the Maintenance Bypass system to the UPS inverter output.

These conditions must be met for this operation to proceed:

- the UPS must be operating normally
- the BIB breaker must be closed
- the UPS system must be supplying the load by the bypass.

NOTICE

Risk of loss of power to the connected load.

Can cause equipment damage.

This procedure must be performed by properly trained and qualified personnel who are knowledgeable about the operation of this system. Failure to follow these instructions will result in loss of power and possible damage to critical equipment.

Before performing this operation, read any messages on the touchscreen to be sure that bypass supply is regular and the inverter is synchronous with it. If those conditions are not present, there is a risk of a short interruption in powering the load.

1. Verify that the Liebert® EXM is in supplying power to the load from the bypass.

**NOTE**

Pressing the Alarm Silence Switch cancels the audible alarm, but leaves the warning message displayed until the appropriate condition is rectified.

2. Open the Liebert MBC door to gain access to the bypass isolation breaker (BIB), maintenance bypass breaker (MBB) and the maintenance isolation breaker (MIB).
3. When the Lamp indicator on the MBC is illuminated, press and hold the adjacent push button and remove the key from the lock (KO).
4. Insert the key into the lock on the MIB, and turn the key.
5. Close the MIB.
6. Verify the MIB is closed. Failure to close the MIB will interrupt power to the load.
7. Open MBB.
8. Remove the key from the lock on the MBB.
9. Insert the key into the lock (KO) and turn the key.

The UPS system is now supplying power to the critical load.

10. Log in as Operator, Administrator or Service.
11. Touch the OPERATE tab.
12. Touch the *Inverter On* button.
13. To continue, confirm turning On the inverter when prompted.

6.8 De-Energize Liebert® EXM with Maintenance Bypass Cabinet

NOTICE

Risk of loss of power to the connected load. Can cause equipment damage.

This procedure must be performed by properly trained and qualified personnel who are knowledgeable about the operation of this system. This procedure will remove power from the critical bus.

Take precautions by providing a backup power supply or shutting down equipment before de-energizing the Liebert EXM.

To de-energize the system:

1. Log in as Operator, Administrator or Service.
2. Touch the OPERATE tab.
3. Touch the *Inverter Off* button.
4. To continue, confirm turning Off the inverter when prompted.
5. Open all battery circuit breakers(s) including the internal battery breaker (if applicable).
6. If the MBC is a Vertiv cabinet, open the Maintenance Isolation Circuit Breaker (MIB). If the MBC is a customer-issued switchgear or a non-Vertiv cabinet, open the breaker(s) that supply power to the critical bus.
7. Open the Rectifier Input Circuit Breaker and Bypass Input Breaker (if dual input). If the MBC is a customer-issued switchgear or a non-Vertiv cabinet, open the breaker(s) that supply power to the UPS input and bypass input (if dual input).
8. Allow 5 minutes for all DC circuits and capacitors to fully discharge.
9. Open the external feeder breaker to the MBC or bypass switchgear.
10. Install a Lockout/Tagout on the external feeder breaker to the MBC or bypass switchgear.
11. Use a digital multimeter to verify there is no AC or DC voltage present at the UPS input, output and bypass bus bars.
12. Use a digital multimeter to verify there is no AC or DC voltage present at the MBC BIB, MIB and MBB breakers.

6.9 De-Energize Liebert® EXM Without Maintenance Bypass Cabinet

NOTICE

Risk of loss of power to the connected load. Can cause equipment damage.

This procedure must be performed by properly trained and qualified personnel who are knowledgeable about the operation of this system. This procedure will remove power from the critical bus.

Take precautions by providing a backup power supply or shutting down equipment before de-energizing the Liebert EXM.

To de-energize the Liebert® EXM:

1. Log in as Operator, Administrator or Service.
2. Touch the OPERATE tab.
3. Touch the *Inverter Off* button.
4. To continue, confirm turning Off the inverter when prompted.
5. Open all battery circuit breakers(s) including the internal battery breaker (if applicable).
6. Open the UPS output circuit breaker(s).
7. Open the UPS input circuit breaker and bypass circuit breaker (dual input systems only).
8. Allow 5 minutes for all DC circuits and capacitors to fully discharge.
9. Use a digital multimeter to verify there is no AC or DC voltage present at the UPS input, output and bypass bus bars.

Figure 29 Typical configuration for single UPS

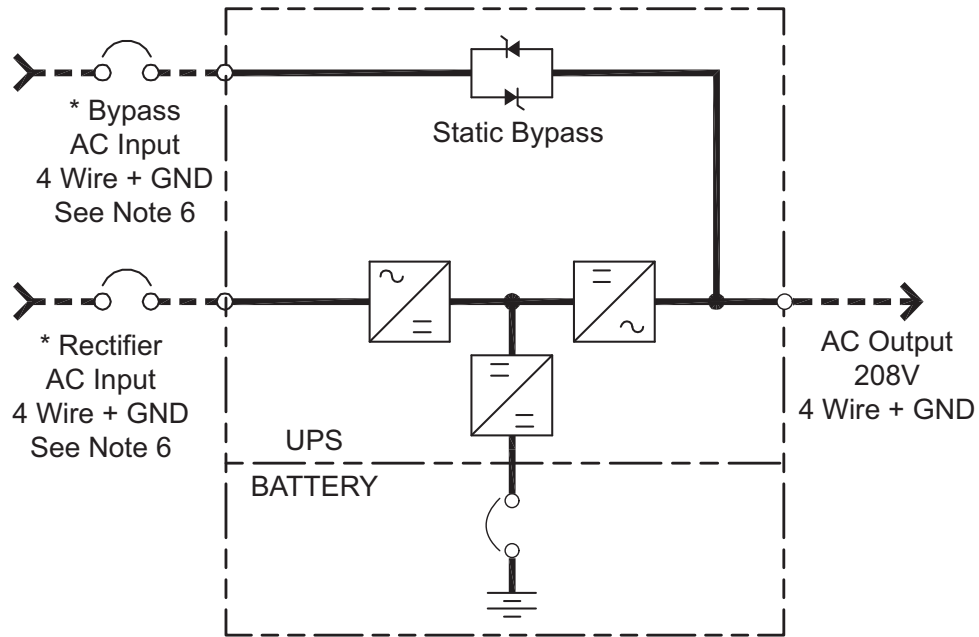

* External Overcurrent Protection By Others

----- Field-Supplied Wiring

Notes:

1. Install in accordance with national and local electrical codes.
2. Input and bypass must share the same single source.
3. A neutral is required from the system AC input source. Vertiv recommends a full-capacity neutral conductor and grounding conductors.
4. Bypass and rectifier inputs and output cables must be run in separate conduits.
5. Control wiring must be run in separate conduits.
6. Customer must supply shunt trip breakers with 120V coils to the bypass and rectifier inputs.

6.10 Parallel Operations—Determine Control Panel Firmware Version

Parallel operation differs depending on the software in the control menu. To determine which version is installed on the UPS, activate the touchscreen menu, touch the Context Menu and touch *About*.

If the firmware is V1.1, perform the appropriate steps in **6.11 - Parallel Operations—Software Version 1.1**.



Context Menu

6.11 Parallel Operations—Software Version 1.1

6.11.1 De-Energize a Liebert® EXM Parallel System—Software Version 1.1

To shut down a UPS parallel system using V1.1 controller software:

1. Log in as Operator, Administrator or Service.
2. Verify that the system and the connected load are prepared for shutdown.
3. Touch the OPERATE tab
4. Touch the *Inverter Off* button. A pop-up window states that the system is operating in a multi-module system and asks whether to control one inverter or the entire system.
5. Touch *System*.

The power module run lights will start flashing yellow while the unit goes through the inverter shutdown sequence. After a few seconds, the inverter will turn Off, the static bypass will close and the power module run lights will be Off. All UPS units in the system will go to bypass

6. Check the parallel switchgear.

NOTICE

Risk of loss of power to the connected load. Can cause equipment damage.

The following procedure will remove power from the critical bus. Before beginning these steps, shut down the connected load or transfer the connected load to an input power supply not dependent on the Liebert® EXM system that is being de-energized.

- a. If the parallel switchgear is a matching Vertiv cabinet, open the Maintenance Isolation Circuit Breaker (MIB).
- b. Open all Module Output Breakers (MOB).
7. Open the input breaker for each UPS and the breaker feeding the Maintenance Bypass Breaker (MBB) in the parallel switch gear.

The system is now de-energized, and its output power supply is Off.

6.11.2 Re-Energize a Liebert® EXM Parallel System—Software Version 1.1

To restart Liebert® EXM parallel system from a fully powered-down condition using V1.1 controller software:

1. Log in as Operator, Administrator or Service.
2. Close the input breakers for all UPS's
3. The LCD on each UPS will turn On, the LCD icons will begin flashing green and the rectifier will start. The bypass and output icons will illuminate green. The battery LED will illuminate red.
4. Close the Module Output Breakers (MOB) circuit breaker to each UPS.
5. Close the MIB circuit breaker.



WARNING

Risk of electric shock. Can cause equipment damage, injury and death.

The following procedure will supply power to the critical bus. Before beginning, notify all personnel that input power is being supplied to the circuits. Verify that the connected load is prepared for input current.

6. Touch the OPERATE tab
7. Touch the *Inverter On* button. A pop-up window states that the system is operating in a multi-module system and asks whether to start one inverter or the entire system.
8. Touch *System*.
The LCD icons will start flashing green while the unit goes through the inverter startup sequence. After about a minute, the inverter will turn On, the static bypass will open and the icons will be solid green.
9. Close all battery breakers.

6.12 Emergency Shutdown With EPO

This circuit has been designed to switch Off the UPS in emergency conditions (e.g., fire, flood, etc.). The system will turn Off the rectifier, inverter and stop powering the load immediately (including the inverter and bypass), and the battery stops charging or discharging.

If the input utility is present, the UPS's controls will remain active; however, the output will be turned Off. To remove all power from the UPS, the external feeder breaker should be opened.

6.13 Auto Restart

When the main and bypass sources fail, the UPS draws power from the battery system to supply the load until the batteries are depleted. When the UPS reaches its end of discharge (EOD) threshold, it will shut down.

The UPS will automatically restart and enable output power:

- after utility power is restored
- if “Auto Recovery after EOD Enabling” is enabled in the UPS configuration (set by factory or by Vertiv Services)
- after the “Auto Recovery after EOD Delay Time” expires (the default delay is 10 minutes)

During the auto recovery delay, the Liebert® EXM will be charging its batteries to provide a safety margin for equipment shutdown if input power fails again.

If the “Auto Recovery after EOD Enabling” feature is disabled, the system must be restarted manually.

6.14 Reset After Shutdown for Emergency Stop (EPO Action) or Other Conditions

Once all appropriate measures have been taken to correct the problem indicated by the alarm message appearing on the Operator Control Panel, carry out this procedure to restore the UPS to regular operation following an EPO action or for the following reasons: Inverter Overtemperature, Cut-Off Overload, Battery Overvoltage, excessive switching (BYP: XFER COUNT BLOCK), etc.

When the user confirms that the fault is cleared:

1. Log in as Operator, Administrator or Service.
2. Touch the OPERATE tab.
3. Touch the yellow *Reset* button to clear the Emergency Power Off state.
4. Press the *Inverter On* button on the right side of the Operator Control Panel for longer than 2 seconds (after the rectifier has qualified).



NOTE

The rectifier will start automatically 5 minutes after the of overtemperature fault is cleared.

After the EPO button is pressed, if the input utility is removed, the UPS will shut down completely. When input utility is restored, the EPO condition will clear, and the UPS will enable the static bypass and restore the output.

6.15 Battery Protection

6.15.1 Battery Undervoltage Warning

Before the end of discharge, the Liebert® EXM displays a low battery warning. After this warning, the battery has the capacity for 5 minutes discharging with full load (default time). The Liebert® EXM can be user-configured to display this warning from 3 to 60 minutes before end-of-discharge.

6.15.2 Battery End-of-Discharge (EOD) Protection

If the battery voltage is lower than the end-of-discharge voltage, the battery converter will be shut down. Refer to **Table 23**.

6.16 Operation



WARNING

Risk of electrical shock and arc flash. Can cause property damage, injury and death.

The Liebert® EXM contains high voltages internally. Components that can only be accessed by opening the protective cover with tools cannot be serviced or replaced by the user.

Only properly trained and qualified service personnel are authorized to remove the protective covers.



AVERTISSEMENT

Risque d'arc ou de décharge électrique pouvant entraîner des dommages matériels, des blessures et même la mort.

L'armoire Liebert® EXM contient des tensions élevées à l'interne. L'utilisateur ne peut ni entretenir ni remplacer des composants accessibles uniquement en ouvrant le couvercle de protection avec des outils.

Seul du personnel de service qualifié et dûment formé est autorisé à retirer les couvercles de protection.

The Liebert® EXM operates in the modes shown in **Table 12**. This section describes various kinds of operating procedures under each operating mode, including transfer between operating modes, UPS setting and procedures for turning on/off inverter.

Table 12 UPS operating modes

Operating Mode		Descriptions
Load on Inverter	NORMAL	UPS powers the load
Load on Bypass	BYPASS	The load power supply is provided by the static bypass. This mode can be regarded as a temporary transition mode between the Load on Inverter Mode and Load on Bypass Mode, or a temporary abnormal operating status.
Maintenance Mode	MAINT	UPS shuts down, the load is connects to the mains through the Liebert MBC. In this mode, the load is not protected against input utility power fluctuations such as spikes, sags and failure.

As shown in SL-25656, the Liebert® EXM Battery Cabinet manual, the AC utility source is supplied through the input breaker, and the rectifier converts the alternating current into DC power. The inverter converts the AC power from the utility—or DC power from an optional External Battery Cabinet—into AC power for the load. The batteries power the load through the inverter in the event of a power failure. The utility source can also power the load through the static bypass.

If maintenance or repair of the UPS is necessary, the load can be switched without interruption in service using the optional Liebert MBC.

6.17 Static Bypass Switch

The circuit block labeled “Static Bypass” contains an electronically controlled switching circuit that enables the critical load to be connected to either the inverter output or to a bypass power source via the static bypass line. During normal system operation, the load is connected to the inverter and the inverter contactor is closed; but in the event of a UPS overload or inverter failure, the load is automatically transferred to the static bypass line.

To provide a clean (no-break) load transfer between the inverter output and static bypass line, the static switch activates, connecting the load to bypass. To achieve this, the inverter output and bypass supply must be fully synchronized during normal operating conditions. This is achieved through the inverter control electronics, which make the inverter frequency track that of the static bypass supply, provided that the bypass remains within an acceptable frequency window.

NOTICE

Risk of power loss to connected load. Can cause damage to equipment.

The load equipment is not protected from normal supply aberrations, such as spikes, sags and failure, when the Liebert® EXM load is supplied by the bypass or maintenance bypass.

7.0 SPECIFICATIONS AND TECHNICAL DATA

7.1 Conformity and Standards

The Liebert® EXM has been designed to conform to the following standards:

Safety	UL1778 4th Edition, CSA 22.2 107.3
Surge	IEC 61000-4-5 Criteria B
Harmonics	IEC 61000-3-4
Electrical Fast Transient	IEC 61000-4-4, Criteria B
ESD	IEC 61000-4-2, Criteria B
FCC	Part 15, Class A
Radiated Immunity	IEC 61000-4-3, Criteria A
Conducted Immunity	IEC 61000-4-6, Criteria A
Low-Frequency Signals	IEC 61000-2-2 Criteria A
Transportation	ISTA Procedure 1H
ISO	9001
Misc	OSHA, ASME, NEMA PE-1

The Liebert® EXM has UL and c-UL approval.

7.1.1 ENERGY STAR® Certification

The Liebert® EXM UPS is ENERGY STAR certified satisfying “ENERGY STAR Program Requirements Product Specification for Uninterruptible Power Supplies (UPSs) - Eligibility Criteria, Version 2.0.”

7.2 UPS Environmental

The Liebert® EXM is designed to operate under the following environmental conditions without damage or degradation in electrical operating characteristics:

Table 13 Environmental requirements

Item	Requirements
Acoustical Noise, dBA, at 55 in. (1.4m)	59
Operating Altitude	4922 ft. (1500m) above mean sea level; 1% maximum kW derate per 328 ft. (100m) rise between 4922 and 9843 ft. (1500m and 3000m)
Relative Humidity	95%
Operating Temperature, °F (°C)	104 (40)
UPS Storage/Transport Temperature, °F (°C)	-4 to 158 (-20 to 70)

Table 14 UPS mechanical characteristics

Rated Power, kVA	10 - 40
Dimensions, W x D x H, in (mm)	23-5/8 x 39-3/8 x 78-3/4 (600 x 1000 x 2000)
Weight, lb (kg)	See Table 1 for weights.
Color	RAL 7021 (Black)
Protection Degree IEC (60529)	IP20

7.3 UPS Electrical Characteristics

Refer to additional circuit breaker notes in **3.2.7 - Accessory Fuses and Back-Feed Breaker Wiring**.



NOTE

The breakers and cables used must be in accordance with NEC ANSI/NFPA 70. A disconnect breaker must be provided for AC input, DC input and AC output. Recommended cable sizes are suitable for operation at a maximum temperature of 104°F (40°C).

Table 15 UPS currents and terminals—Input (for single-input unit, 208V operation)

Unit Rating	Nominal Input Current	Maximum Input Current	OCP Device Rating	Bolt Size	75°C Wire Current, Total	Copper Wire	Aluminum Wire
10	30	34	45	M10	65	(1) #6	(1) #4
15	45	51	70	M10	85	(1) #4	(1) #2
20	59	68	90	M10	115	(1) #2	(1) 1/0
30	89	102	150	M10	175	(1) 2/0	(1) 4/0
40	119	136	175	M10	230	(1) 4/0	(2) 1/0

Table 16 UPS currents and terminals—Input (for dual-input unit only, 208V operation)

Unit Rating	Nominal Input Current	Maximum Input Current	OCP Device Rating	Bolt Size	75°C Wire Current Total	Copper Wire	Aluminum Wire
10	30	34	45	M10	65	(1) #6	(1) #4
15	45	51	70	M10	85	(1) #3	(1) #2
20	59	68	90	M10	115	(1) #2	(1) 1/0
30	89	102	150	M10	175	(1) 2/0	(1) 4/0
40	119	136	175	M10	230	(1) 4/0	(2) 1/0

Table 17 UPS currents and terminals—Bypass input (for dual-input units, 208V operation)

Unit Rating	Nominal Input Current	OCP Device Rating	Bolt Size	75°C Wire Current, Total	Copper Wire	Aluminum Wire
10	28	40	M10	50	(1) #6	(1) #2
15	42	60	M10	85	(1) #4	(1) #2
20	56	70	M10	115	(1) #2	(1) #2
30	83	110	M10	130	(1) #1/0	(1) 2/0
40	111	150	M10	175	(1) 3/0	(1) 4/0

Table 18 UPS currents and terminals—Output 208V

Unit Rating	Nominal Output Current	OCP Device Rating	Bolt Size	75°C Wire Current, Total	Copper Wire	Aluminum Wire
10	28	40	M10	50	(1) #6	(1) #2
15	42	60	M10	85	(1) #4	(1) #2
20	56	70	M10	115	(1) #2	(1) #2
30	83	110	M10	130	(1) #1/0	(1) 2/0
40	111	150	M10	175	(1) 3/0	(1) 4/0

Table 19 AC/AC efficiency, loss and air exchange

AC/AC Efficiency		Data				
Load on Inverter (dual conversion), %		95.6% Max				
Inverter Efficiency (DC/AC) (Battery at Nominal Voltage 288 VDC and Full-Rated Linear Load)						
Rated Power, kVA		10-40K				
Load on Battery, %		94.8% Max				
Heat Losses & Air Exchange						
Rated Power, kVA	10	15	20	30	40	
Load on Inverter, kW	0.45	0.675	0.9	1.35	1.8	
No Load, kW	0.3	0.3	0.3	0.6	0.6	
Maximum Forced Air Cooling (Front Intake, Rear Exhaust), L/sec (m ³ /hr)	32 (115)	32 (115)	32 (115)	64 (231)	64 (231)	
Heat Dissipation, BTU/Hr (kWH)++	2217 (0.65)	3245 (0.95)	3843 (1.13)	6189 (1.81)	7610 (2.23)	

Table 20 Rectifier input

Parameter	10-40kVA
Rated AC Input Voltage	208/120V or 220/127V, 50/60Hz, 3-Phase, 4-Wire Plus Ground
Input Voltage Range, Startup/Operating	102-146VAC
Input Voltage Range, Operating	72-146VAC (72-102VAC Derating)
Frequency	50 or 60Hz (40-70Hz Range)
Power Factor	0.99 Full Load, 0.98 Half Load
Input Current, Rated	29/44/59/88/117
Input Current, Max	33/51/68/101/135
THD	5% Full load

Table 21 Recommended lug sizes (compression type) M10, 3/8" bolt

Cable Size	T&B Copper One Hole	T&B Aluminum One Hole
#8AWG	54132	60104-TB
#6AWG	54136	60109
#4AWG	54140	60114
#2AWG	54143	60118
#1AWG	54148	60124
#1/0AWG	54109	60130
#2/0AWG	54110	60136
#3/0AWG	54111	60142
#4/0AWG	54112	60148
250kcmil	54174	60154
300kcmil	54179	60160
350kcmil	256-30695-112	—
400kcmil	256-30695-1403	—
500kcmil	256-30695-339	—

Table 22 Battery cabinet system—UPS and battery cabinet

UPS Rating, kVA	Battery Cabinet Breaker	Maximum Battery Current, A	Battery Cabinet Size, mm
10-40	225A	187	320, 600, 880

Table 23 Battery DC intermediate circuit

Parameter	10 - 40kVA
Battery Bus Voltage	288
Number of Lead-Acid Cells	144 = (24 x 6 cell [12V] blocks), nominal
Float Voltage	2.25V/cell, selectable from 2.2 - 2.3V/cell
Temperature Compensation	-3.0mV/°C, selectable from 0 to -5.0mV/°C around 77°F (25°C) or 86°F (30°C) or inhibit
Ripple Voltage	≤1%
Ripple Current	≤5%
Boost Charge Voltage	2.35V/cell (selectable from 2.30-2.40V/cell)
Boost Control	Float-boost current trigger 0.050 C10 (selectable 0.030-0.070) Boost-float current trigger 0.010 C10 (selectable 0.005-0.025) 24 hr safety time-out (selectable 8-30 hr) Boost charge mode inhibit also selectable
End of Discharge	1.63 V/cell for lower EOD timer. (10-45 minutes, 15 default) 1.75 V/cell for upper EOD timer. (46-180 minutes, 60 default)
Battery Charge	2.35 V/cell (selectable from 2.3-2.4V/cell) Constant current and constant voltage charge mode Programmable auto trigger or inhibit of boost mode
Battery Charging Power Maximum Current	UPS (kVA) 10, 15, 20, 30, 40 Battery Charging Power (kW) 1.5, 2.25, 3.0, 4.5, 6 Maximum Charging Current (A) 4, 7, 9, 13, 18

Table 24 Inverter output to critical load

Parameter	10-40kVA
Rated AC Voltage	208/120V or 220/127V, 50/60Hz, 3-Phase, 4-Wire Plus Ground
Frequency *	50/60
Overload Capacity	105% - 110% of full load for 60 minutes at 104°F (40°C) ambient 110% - 125% of full load for 10 minutes at 104°F (40°C) ambient 125% - 150% of full load for 60 seconds at 104°F (40°C) ambient >150% of full load for a minimum of 200 milliseconds at 104°F (40°C) ambient
Fault Current	Short Circuit for 200 ms
Non-Linear Load Capability	100%
Neutral Current Capability	170%
Steady State Voltage Stability	±1% (balanced load)
Voltage Regulation	±1% for balanced load ±5% for 100% unbalanced load
Phase Balance	120° ±1° for balanced load 120° ±15°± for 100 unbalanced load
Transient Voltage Response	5%
THD	<1.5% (0-100% linear load) <4% (0-100% non-linear load)
Sync Frequency Range	Rated Frequency ± 2Hz (selectable ± 0.5 to ± 3Hz)
Frequency Slew Rate	0.1-3Hz
Frequency Regulation	±0.1% (Single Power Module) ±0.25% (Two Power Modules)
Voltage Adjustment Range	±5%

* Factory-set to 60Hz; 50Hz selectable by commissioning engineer. Frequency converter operation is also selectable.

Table 25 Bypass input

Parameter	10-40kVA
Rated AC Voltage	208/120V or 220/127V, 50/60Hz, 3-Phase, 4-Wire Plus Ground
Rated Current: 208V	29/44/59/88/117
220V	26/39/52/79/105
Overload	110% load, Continuous
Upstream Protection, Bypass Line	Thermomagnetic Circuit Breaker, rated up to 125% of nominal output current
Current Rating of Neutral Cable, A	1.7*In
Frequency, Hz	50 or 60
Transfer Time Between Bypass and Inverter, ms	Uninterrupted Transfer: <1ms Interrupted Transfer: <20ms(40,60,80,100, can be selected)
Bypass Voltage Tolerance, %VAC	Upper Limit: +10, +15 or +20, default +15 Lower Limit: -10, -20, -30 or -40; default: -20 (delay time to accept steady bypass voltage: 10 sec)
Bypass Frequency Tolerance, %	±10% or ± 20% default: ± 20%
Synchronization-Window	±0.5, 1,2,3Hz Default: ±2Hz

8.0 MAINTENANCE

8.1 Safety Precautions

Observe the safety precautions in **Important Safety Instructions on page 1**.

Only properly trained and qualified personnel should perform maintenance on the UPS system.

Observe all of the warnings and cautions below before performing any maintenance on the UPS system and associated equipment. Also observe the manufacturer's safety precautions pertaining to the battery, along with the battery safety precautions in this document.



WARNING

Risk of electrical shock and high short circuit current. Can cause equipment damage, injury and death.

Always identify connecting wiring prior to disconnecting any wiring.

Do not substitute parts except as authorized by Vertiv™.

Maintain the UPS cabinets free of foreign materials such as solder, wire cuttings, etc.

Contact Vertiv Services if there is any uncertainty about the procedures to follow or if personnel are unfamiliar with the circuitry.



AVERTISSEMENT

Risque de décharge électrique et de présence de courant de court-circuit élevé pouvant entraîner des dommages matériels, des blessures et même la mort.

Identifiez tous les circuits de connexion avec de débrancher des câbles.

Ne remplacez aucun composant sans l'autorisation expresse d'Vertiv.

Assurez-vous que les armoires d'ASC sont exemptes de matériaux étrangers tels que des résidus de soudure, des bouts de câble, etc.

Communiquez avec Vertiv Services si vous doutez de la procédure à suivre ou si les circuits ne vous sont pas familiers.



WARNING

Risk of electrical shock and arc flash. Can cause property damage, injury and death.

Only Vertiv or Vertiv-trained service personnel should work on this equipment. Both AC and DC high voltages are present in lethal amounts within this equipment. Extreme care should be taken when working around UPS equipment.

Always identify the source of connecting wiring prior to disconnecting. Mark any disconnected wires, so they can be properly reconnected.

Do not substitute parts except as authorized by Vertiv.

Maintain the UPS cabinets free of foreign materials such as solder, wire cuttings, etc.

Call Vertiv Services if you are not sure of the procedures to follow or if you are not familiar with the design or operation of the equipment.



AVERTISSEMENT

Risque d'arc ou de décharge électrique pouvant entraîner des dommages matériels, des blessures et même la mort.

L'entretien et la réparation de cet équipement doivent être confiés exclusivement à un personnel qualifié de Vertiv™ ou formé par Vertiv™. Des hautes tensions c.a. et c.c. mortelles sont présentes dans cet équipement. Faites preuve d'une grande prudence lorsque vous travaillez à proximité d'un système ASC. Identifiez toujours la source d'un câble de raccordement avant de le débrancher. Identifiez les câbles déconnectés afin de pouvoir les reconnecter correctement.

Ne remplacez aucun composant sans l'autorisation expresse de Vertiv.

Assurez-vous que les armoires d'ASC sont exemptes de matériaux étrangers tels que des résidus de soudure, des bouts de câble, etc.

Communiquez avec Vertiv Services si vous doutez de la procédure à suivre ou si la conception ou le fonctionnement de l'équipement ne vous sont pas familiers.



WARNING

Risk of electrical shock and high short circuit current. Can cause equipment damage, personal injury and death.

Extreme caution is required when performing maintenance.

Be constantly aware that the UPS contains high DC as well as AC voltages. With input power Off and the DC source disconnected, high voltage at filter capacitors and power circuits should be discharged within 5 minutes. However, if a power circuit failure has occurred, assume that high voltage may still exist after shutdown. Check with a voltmeter before making contact.

AC voltage will remain on the bypass and output circuit breakers and the static bypass switch, unless associated external circuit breakers are opened.

Check for voltage with both AC and DC voltmeters before making contact.

When the UPS is under power, both the operator and any test equipment must be isolated from direct contact with earth ground and the UPS chassis frame by using rubber mats.

Some components within the cabinets are not connected to chassis ground.

Any contact between floating circuits and the chassis is a lethal shock hazard. Use differential oscilloscopes when measuring a floating circuit.

Exercise caution that the test instrument exterior does not make contact, either physically or electrically, with earth ground.

In case of fire involving electrical equipment, use only carbon dioxide fire extinguishers or others approved for use in fighting electrical fires.



AVERTISSEMENT

Risque de décharge électrique et de présence de courant de court-circuit élevé pouvant entraîner des dommages matériels, des blessures et même la mort.

Les opérations d'entretien requièrent une extrême prudence.

Soyez toujours conscient du fait que le système ASC contient des tensions c.c. et c.a. élevées. Une fois l'alimentation d'entrée coupée et la source d'alimentation c.c. débranchée, la haute tension aux condensateurs de filtrage et aux circuits d'alimentation devrait se dissiper en moins de 5 minutes. En cas de défaillance d'un circuit d'alimentation, toutefois, il importe de présumer qu'une tension élevée est présente même après l'arrêt. Vérifiez toujours les tensions avec un voltmètre avant d'établir des contacts.

Les disjoncteurs de dérivation et de sortie, de même que le commutateur statique de dérivation, continueront d'afficher une tension c.a. à moins que les disjoncteurs externes associés ne soient ouverts.

Vérifiez les tensions avec des voltmètres c.a. et c.c. avant d'établir tout contact.

Lorsque le système ASC est sous tension, les responsables de l'entretien et l'équipement d'essai doivent reposer sur des tapis de caoutchouc pour prévenir tout contact direct avec le sol et avec le châssis du système lors des interventions.

Certains composants à l'intérieur des armoires ne sont pas connectés à la masse du châssis.

Tout contact entre les circuits flottants et le châssis présente un risque de décharge mortelle. Utilisez des oscilloscopes différentiels lors des mesures d'un circuit flottant.

Il importe de veiller à ce que l'extérieur des équipements d'essai n'entre pas en contact physique ou électrique avec le sol.

En cas d'incendie associé à du matériel électrique, n'utilisez que des extincteurs à dioxyde de carbone ou homologués pour la lutte contre les incendies d'origine électrique.

8.2 Battery Maintenance



WARNING

Risk of electrical shock and arc flash. Can cause property damage, injury and death.

These maintenance procedures will expose hazardous live parts. Refer servicing to properly trained and qualified personnel.



AVERTISSEMENT

Risque d'arc ou de décharge électrique pouvant entraîner des dommages matériels, des blessures et même la mort.

Les procédures d'entretien ci-dessous exposent des composants sous tension dangereuse. Les interventions d'entretien doivent être confiées à du personnel qualifié et dûment formé.

8.3 Battery Safety Precautions

Servicing of batteries should be performed or supervised by personnel experienced with batteries and the required precautions. Keep unauthorized personnel away from batteries.

When replacing batteries, use the same number and type of batteries.



WARNING

Risk of electrical shock. Can cause personal injury and death.

Check for voltage with both AC and DC voltmeters before working within the UPS. Check for voltage with both AC and DC voltmeters before making contact.

Only properly trained and qualified personnel wearing appropriate safety headgear, gloves, shoes and glasses should be involved in installing the UPS or preparing the UPS for installation. When performing maintenance with any part of the equipment under power, service personnel and test equipment should be standing on rubber mats.

Lead-acid batteries contain hazardous materials. Batteries must be handled, transported and recycled or discarded in accordance with federal, state and local regulations. Because lead is a toxic substance, lead-acid batteries must be recycled rather than discarded.

Do not dispose of battery or batteries in a fire. The battery may explode.

Do not open or mutilate the battery or batteries. Released electrolyte is harmful to the skin and eyes. It is toxic.

The following precautions must be observed when working on batteries:

- Remove watches, rings and other metal objects.
- Use tools with insulated handles.
- Wear rubber gloves and boots.
- Do not lay tools or metal parts on top of batteries.
- Disconnect charging source prior to connecting or disconnecting battery terminals.
- Determine whether the battery is grounded. If it is grounded, remove source of ground.

Contact with any part of a grounded battery can result in electrical shock. The likelihood of such shock will be reduced if such grounds are removed during installation and maintenance.



AVERTISSEMENT

Risque de décharge électrique pouvant causer des blessures graves, voire mortelles.

Vérifiez les tensions au moyen de voltmètres c.a. et c.c. avant d'utiliser le système ASC. Vérifiez les tensions avec des voltmètres c.a. et c.c. avant d'établir tout contact.

Seuls des employés qualifiés et dûment formés portant un casque, des gants, des chaussures et des lunettes de sécurité adéquats doivent se charger d'installer le système ASC ou de le préparer pour l'installation. Les responsables de l'entretien et l'équipement d'essai doivent reposer sur des tapis de caoutchouc lors de toute intervention sur une pièce d'équipement sous tension.

Les batteries au plomb-acide renferment des matières dangereuses. Les batteries doivent être manipulées, transportées, recyclées ou jetées conformément aux règlements fédéraux, provinciaux et municipaux. Étant donné que le plomb est une substance toxique, les batteries au plomb-acide doivent être recyclées plutôt que mises au rebut.

Ne jetez jamais de batteries au feu car elles risquent d'exploser.

Vous ne devez ni ouvrir ni percer les batteries, car l'électrolyte qui s'en écoulait est nocif pour la peau et les yeux. Cet électrolyte est toxique.

Lorsque vous travaillez avec des batteries, prenez les précautions suivantes :

- Retirez montre, bagues et tout autre objet métallique.
- Utilisez des outils dont le manche est isolé.
- Portez des gants et des bottes de caoutchouc.
- Ne posez aucun outil ni pièce métallique sur le dessus d'une batterie.
- Déconnectez la source de chargement avant de brancher ou de débrancher les bornes d'une batterie.
- Vérifiez si la batterie est mise à la terre. Le cas échéant, éliminez la cause de la mise à la terre.

Le contact avec toute partie d'une batterie mise à la terre peut provoquer une décharge électrique. Pour réduire de tels risques d'accident, débranchez les prises de terre avant de procéder à l'installation ou à l'entretien.

Regular maintenance of the battery module is an absolute necessity. Periodic inspections of battery and terminal voltages, specific gravity, and connection resistance should be made. Strictly follow the procedures outlined in the battery manufacturer's manual. (See battery manufacturer's web site.)

Valve-regulated lead-acid batteries do require periodic maintenance. Although they do not require maintenance of electrolyte levels, visual inspections and checks of battery voltage and connection resistance should be made.

NOTICE

Risk of damage to battery cases. Do not use cleaners on the batteries. Solvents can make the battery cases brittle. Use only a dry cloth or a cloth moistened in water

Since individual battery characteristics are not identical and may change over time, the UPS module is equipped with circuitry to equalize battery cell voltages. This circuit temporarily increases charging voltage to maintain flooded type battery cells at full capacity.



WARNING

Risk of electric shock, explosive reaction, hazardous chemicals and fire. Can cause equipment damage, personal injury and death.

Do not use equalize charging with valve-regulated, lead-acid batteries, such as those used in Liebert battery cabinets. Refer to the battery manufacturer's manual, available on the manufacturer's Web site, for specific information about equalize charging.



AVERTISSEMENT

Risque de décharge électrique, de réaction explosive, d'incendie et d'exposition à des produits chimiques dangereux pouvant entraîner des dommages matériels, des blessures et même la mort.

N'utilisez pas de charge d'égalisation avec des batteries d'accumulateurs au plomb à régulation par soupape, comme celles utilisées dans les armoires de batterie Liebert. Reportez-vous au manuel du fabricant des batteries, disponible sur le site Web du fabricant, pour obtenir des renseignements précis sur la charge d'égalisation.

8.4 Limited-Life Components

The Liebert EXM UPS has a design life well in excess of 10 years. Well-maintained units can continue to provide economic benefits for 20 years or more. Long-life components are used in the UPS wherever practical and cost effective. However, due to the currently available component material, manufacturing technology limitations and the general function and use of the component, a few components in your Liebert UPS will have a shorter life cycle and require replacement in less than 10 years.

The following components utilized in your UPS system have a limited life cycle and are specifically exempt from warranty. To prevent a wear-out failure of one of these components affecting your critical load operations, Vertiv recommends these components be periodically inspected and replaced before the expected expiration of their life cycle. The expected life of each component listed below is simply an estimate and is not a guarantee. Individual users may have site-specific requirements, maintenance and other environmental conditions that affect the length of the component's useful life cycle. .

Table 26 Component service life

Component	Expected Life	Replace in:
Air filters	5 years	Check four times per year
Power Modules & Static Bypass Assembly	20 years	18 years
Frame Fans	10 years	8 years



NOTE

Component Expected Life requires ambient temperature conditions <25° C. If temperature conditions are higher, expected life will be shorter.

In most cases, replacement components must exactly match the original component specifications. These replacement components are not readily available from third-party component distributors. For assistance with your specific component specifications, replacement component selection and sourcing, call 1-800-LIEBERT. For customers using Vertiv Services' preventive maintenance services, periodic inspection of these components is part of this service, as well as recommending component replacement intervals to customers to avoid unanticipated interruptions in critical load operations.

8.5 Routine Maintenance

Become thoroughly familiar with the equipment, but at no time go beyond the specific procedures in this manual while performing maintenance or correcting a malfunction. If you have any doubt as to what must be done, call

Vertiv Services at 800-543-2378 for further instructions. The UPS is designed for unattended operation, but does require some common sense maintenance.

- Keep good records—Troubleshooting is easier if you maintain historical service records.
- Keep the UPS free of dust and any moisture.
- Keep the UPS cool:
 - Battery systems must be kept in the range of 72-77°F (22-25°C) in order to meet design specifications for capacity and longevity.
 - The UPS will reliably meet all performance specifications at temperatures up to 104°F (40°C), and can be slightly derated for operation at even higher temperatures. However, performance and longevity will be optimized when the UPS is operated at the same temperature as the batteries.
- Keep connections tight.
- Tighten all connections at installation and at least annually thereafter. (See **8.5.3 - Torque Requirements**).

8.5.1 Record Log

Set up a maintenance log to record scheduled checks and any abnormal conditions.

The log should have space for all metered data including phase readings, alarm messages, UPS mode of operation, air filter replacement date and observation notes. A second log should be maintained for the battery module as directed by the battery manufacturer.

Vertiv recommends a periodic walk-through inspection of the UPS and battery rooms to check for visible and audible indications of problems. Log the inspection, metered parameter indications and any discrepancies.

8.5.2 Air Filters

The air filters must be inspected and serviced on a regular schedule. The period between inspections will depend upon environmental conditions. Under normal conditions, the air filters will require cleaning or replacement approximately every two months.

All Liebert® EXM models have replaceable filter elements behind the grille in the front of the unit. This element can be changed with the UPS operating by opening the outer door. The Liebert EXM's air filters are washable and reusable. One set of air filters is shipped with each Liebert® EXM.

Abnormal or dusty conditions will require more frequent cleaning and replacement of air filters. Inspect installations in new buildings more often, then extend the inspection period as experience dictates.

Replacing Air Filters

Installing the two air filter sizes in a Liebert® EXM requires only a Phillips screwdriver. Each filter is held in place by a bracket on either side of each filter. Refer to **8.5.2 - Air Filters** for details about filter maintenance.

To replace a filter:

1. Open the UPS front door and locate the filters on the back side of the front door (see **Figure 30**).
2. Remove one bracket and loosen the screw on the second bracket. The second bracket need not be removed.
3. Remove the dust filter to be replaced.
4. Insert the clean filter.
5. Reinstall the bracket, tightening the screw securely.
6. Tighten the screw on the second bracket.

Figure 30 Air filter replacement

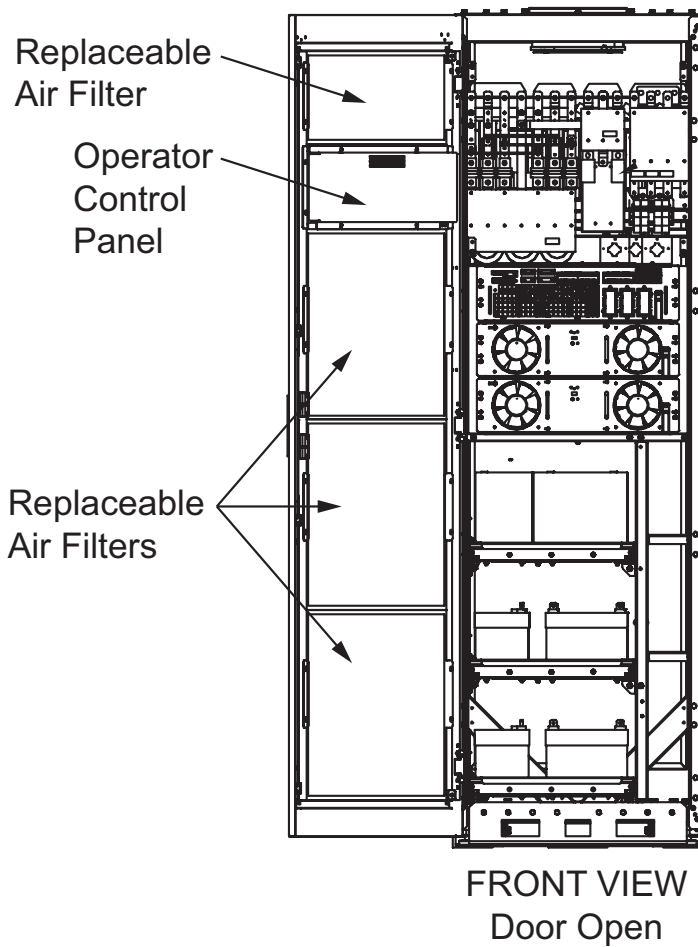

8.5.3 Torque Requirements

All electrical connections must be tight.

Tables 27 through **28** provide the torque values for the connections in the UPS and batteries. Use these values unless the equipment is labeled otherwise.

Table 27 Busbars (for power wiring)

Bolt Shaft Size	Lb-in (Nm)
3/8" (M10)	192 (22)
1/2" (M12)	428 (48)

Table 28 Terminal block with compression lugs (for control wiring)

AWG Wire Size or Range	Lb-in (Nm)
#22 - #14	3.5 to 5.3 (0.4 to 0.6)

8.6 Detecting Trouble

It is important that the operator check the instrument readings if abnormal equipment performance is suspected. Any metered value that differs appreciably from normal could mean an impending malfunction, and should be investigated.

Items to check on the various UPS display screens include:

1. Output voltage of all phases should be within 2% of normal voltage. Output currents on each phase should not normally differ by more than 20%. If a greater difference is noted, the load is unbalanced and corrective action should be taken to redistribute the load, if possible.
2. If the UPS has not operated on battery power during the last 10 hours, the batteries should require little charging current. Battery mimic should indicate normal DC voltage with relatively little battery charge current.
3. Input current on each phase should be within 10% of the average input current. Alarm messages indicate malfunction or impending malfunction. A daily check of the Operator Control Panel will help to provide an early detection of problems. Refer to **Appendix B - UPS Status Messages** to interpret alarm messages.
4. Tracing a problem to a particular section is facilitated by alarm messages and the metered parameter indications. These are stored in the Status Reports and can be displayed at the Operator Control Panel or at an optional terminal.



NOTE

If the UPS system has a blown fuse, the cause should be determined before you replace the fuse. Contact Vertiv Services.

8.7 Reporting a Problem

If a problem occurs within the UPS, review all alarm messages along with other pertinent data. This information should be given to the Vertiv Services dispatcher. Call 800-543-2378 to report a problem or to request assistance.

8.8 Corrective Actions

Recommended corrective actions for each alarm message on the Operator Control Panel and the Remote Alarm Status Panel may be found in **Appendix B - UPS Status Messages**.

8.9 Recommended Test Equipment

Table 29 lists recommended test equipment and tools required to maintain, troubleshoot and repair the UPS module. Instruments of equivalent range and accuracy may be substituted. All instruments should be calibrated and be within the current calibration cycle. Calibration data for the instruments should be maintained in equipment-history files and the instruments labeled for audit and verification.

Table 29 Recommended test equipment and tools

Qty	Test Equipment	Manufacturer	Model or Type
1	Oscilloscope	Tektronix, H-P or Fluke	DC to 50 MHz
2	Voltage Probes	Tektronix, H-P or Fluke	10X, with 10 ft. Cable
2	Voltage Probes	Tektronix, H-P or Fluke	100X, with 10 ft. Cable
1	Digital Multi-meter	Fluke	8060, with Test Leads
1	Tool Kit	N/A	Standard electrical contractor tools

APPENDIX A - HAZARDOUS SUBSTANCES OR ELEMENTS ANNOUNCEMENT

Table 30 Hazardous substances or elements

Part Name	Hazardous Substances					
	Lead (Pb)	Mercury (Hg)	Cadmium (Cd)	Chrome (Cr6+)	Polybrominated Biphenyl (PBB)	Polybrominated Diphenyl Ethers (PBDE)
Hex copper stud	X	4	4	4	4	4
PCBA	X	4	4	4	4	4
AC capacitor	X	4	4	4	4	4
DC capacitor	X	4	4	4	4	4
Fan	X	4	4	4	4	4
Cables	X	4	4	4	4	4
LCD	X	X	4	4	4	4
Sensors	X	4	4	4	4	4
Large-medium power magnetic components	X	4	4	4	4	4
Circuit breaker / rotating switch	X	4	4	4	4	4
Semiconductors	X	4	4	4	4	4
Battery (when applicable)	X	4	4	4	4	4
Insulation monitoring device (when applicable)	X	4	4	4	4	X

4 - Means the content of the hazardous substances in all the average quality materials of the part is within the limits specified in SJ/T-11363-2006

X - Means the content of the hazardous substances in at least one of the average quality materials of the part is outside the limits specified in SJ/T11363-2006

Vertiv has been committed to the design and manufacturing of environment-friendly products. It will reduce and eventually eliminate the hazardous substances in the products through unremitting efforts in research. However, limited by the current technical level, the following parts still contain hazardous substances due to the lack of reliable substitute or mature solution:

1. All solders in the products contain lead.
2. Copper alloy contains lead.
3. Backlight bulb contains mercury.
4. The ceramic materials of the ceramic capacitor, the copper terminals and copper leads of metallic film capacity contain lead.
5. The glass of resistor contains lead.
6. The glass of LCD contains lead, and the backlight lamp contains mercury.
7. The lead in the battery is determined by the battery feature and technical levels.
8. The insulation monitoring device contains lead and PBDE.

About Environment Protection Period: The Environment Protection Period of the product is marked on the product. Under normal working conditions and normal use of the products observing relevant safety precautions, the hazardous substances in the product will not seriously affect the environment, human safety or property in the Environment Protection Period starting from the manufacturing date.

About Battery: The battery life is dependent on the ambient temperature and charging / discharging times. The battery life will be shortened if the battery is used under high temperature or in deep discharging status. Refer to the manufacturer's product literature for details.

APPENDIX B - UPS STATUS MESSAGES

Table 31 shows all event messages as they appear in the current status area of the LCD or the history log, along with a description and recommended actions, if any.

Table 31 UPS status messages

Event Message	Description / Suggested Action (if any)
Comm. Fail	The CAN communication between internal monitor and rectifier/inverter/bypass fails. Contact Vertiv Services at 800-543-2378 for assistance.
Battery Overtemp	The battery temperature is over the limit. Check the battery temperature and ventilation.
Ambient Overtemp	The ambient temperature is over limit. Check the ventilation of UPS room.
Replace Battery	Battery should be replaced. Contact Vertiv Services at 800-543-2378 for assistance.
Battery Low Pre-warning	Before the end of discharging, battery undervoltage pre-warning should occur. After this pre-warning, battery should have the capacity for 3 minutes discharging with full load. The time is user configured from 3 to 60 minutes. Shut down the load in time.
Battery End of Discharge	Inverter turned off due to low battery voltage. Check the utility failure and try to fix it.
Mains Volt. Abnormal	Mains voltage exceeds the upper or lower limit and results in rectifier shutdown. Check the input line-to-neutral voltage amplitude of rectifier.
Mains Undervoltage	Mains voltage is undervoltage (120V~132V). Check the input line-to-line voltage amplitude of rectifier.
Mains Freq. Abnormal	Mains frequency is out of limit range and results in rectifier shutdown. Check the rectifier's input voltage frequency.
Rectifier Fault	Rectifier fault; contact Vertiv Services at 800-543-2378 for assistance.
Rectifier Overtemp	The temperature of the heat sink is too high to keep the rectifier running. The UPS can recover automatically. Check the environment and ventilation.
Charger Fault	The charger has failed. Contact Vertiv Services at 800-543-2378 for assistance.
Input Fuse Fail	Input fuse is open. Contact Vertiv Services at 800-543-2378 for assistance.
Control Power 1 Fail	Control Power 1 has failed or has been lost. Contact Vertiv Services at 800-543-2378 for assistance.
Mains Phase Reversed	Input phase sequence is reversed. Contact Vertiv Services at 800-543-2378 for assistance.
Soft Start Fail	Rectifier could not start due to low DC bus voltage. Contact Vertiv Services at 800-543-2378 for assistance.
Bypass Unable to Trace	This alarm is triggered by an inverter software routine when the amplitude or frequency of bypass voltage is beyond the normal range. The amplitude threshold is fixed for positive and negative 10% rating. This alarm automatically resets once the bypass voltage goes normal. 1. First verify that the bypass voltage and frequency displayed on the panel is within the selected range. Note here the rated voltage and frequency are specified by "Output voltage level" and "Output frequency level" respectively. 2. If the displayed voltage is believed to be abnormal, then verify the bypass voltage and frequency presented to the UPS. Check the external supply if it is found to be faulty. Contact Vertiv Services at 800-543-2378 for assistance.

Table 31 UPS status messages (continued)

Event Message	Description / Suggested Action (if any)
Bypass Abnormal	<p>This alarm is triggered by an inverter software routine when the amplitude or frequency of bypass voltage exceeds the limit. This alarm automatically resets once the bypass voltage goes normal. First check if there are some relevant alarms such as “Bypass disconnect open”, “Bypass phase reverse” and “Mains neutral lost”. If they appear, solve them first.</p> <ol style="list-style-type: none"> 1. Then verify that the bypass voltage and frequency displayed on the panel is within the bypass limit. Note here the rated voltage and frequency are specified by “Output voltage level” and “Output frequency level” respectively. 2. If the displayed voltage is believed to be abnormal, then verify the bypass voltage and frequency presented to the UPS. Check the external bypass supply if it is found to be faulty. If the utility is likely to trigger this alarm frequently, the bypass limit can be changed a little larger through the configuration software according to the customer’s agreement. Contact Vertiv Services at 800-543-2378 for assistance.
Inverter Asynchronous	<p>This alarm is triggered by an inverter software routine when the inverter and bypass waveforms are misaligned by more than 6 degrees in phase. This alarm resets automatically once the condition is no longer true.</p> <ol style="list-style-type: none"> 1. First check if the alarm “Bypass unable to trace” or “Bypass abnormal” occurs. If so, solve it first. 2. Verify the waveform of the bypass voltage. If it is too distorted, ask the customer to verify and seek any possible measurements. Contact Vertiv Services at 800-543-2378 for assistance.
Inverter Fault	<p>This alarm indicates a fault condition exists within the inverter. Contact Vertiv Services at 800-543-2378 for assistance.</p>
Fan Fault	<p>At least one of the cooling fans failed. Contact Vertiv Services at 800-543-2378 for assistance.</p>
Inverter STS (relay) Fail	<p>At least one of the static switches of inverter side is open or short circuit. This fault is locked until power off. Contact Vertiv Services for assistance at 800-543-2378 for assistance.</p>
Bypass STS Fail	<p>At least one of the static switches of bypass side is open or short circuit. This fault is locked until power off. Contact Vertiv Services at 800-543-2378 for assistance.</p>
Output Fuse Fail	<p>At least one of the output fuses is open. Contact Vertiv Services at 800-543-2378 for assistance.</p>
Control Power 2 Fail	<p>Control Power 2 is abnormal or lost. Contact Vertiv Services at 800-543-2378 for assistance.</p>
Unit Overload	<p>The UPS is confirmed to be overload when the load arises above 105% nominal rating. The alarm automatically resets once the overload condition is removed.</p> <ol style="list-style-type: none"> 1. Confirm that the alarm is true by checking the load percent indicated on the LCD panel to determine which phase is being overloaded. 2. If the alarm is true, measure the actual output current to verify that the indications are valid. Disconnect unnecessary load and ensure the safety. In a parallel system, a severe load sharing error can also leads to the alarm. Contact Vertiv Services at 800-543-2378 for assistance.
System Overload	<p>The UPS parallel system is confirmed to overload when the total load arises above 105% nominal rating for the set basic number of UPSs. The alarm automatically resets once the overload condition is removed.</p> <ol style="list-style-type: none"> 1. Confirm that the alarm is true by checking the system load percent indicated on the LCD panel to determine which phase is being overloaded. 2. If the alarm is true, measure the actual output current to verify that the indications are valid. Disconnect unnecessary load and ensure the safety. In a parallel system, a severe load sharing error can also leads to the alarm.
Unit Overload Timeout	<p>The UPS is confirmed to overload and the overload times out.</p> <p>Note 1: The highest loaded phase will indicate overload timing-out first.</p> <p>Note 2: When the timer is active, then alarm “unit overload” should also be active as the load is above nominal.</p> <p>Note 3: When the timer has expired, the inverter Static Switch is opened and the load transferred to bypass. The inverter shutdown and will restart after 10 seconds.</p> <p>Note 4: If the load decreases lower than 95% after 5 minutes, the system will transfer back to inverter mode. Confirm that the alarm is genuine by checking the load percent indicated on the LCD. If an overload is indicated then check the load, and investigate any additional load connected prior to the alarm (if applicable).</p>

Table 31 UPS status messages (continued)

Event Message	Description / Suggested Action (if any)
Bypass Phase Reversed	The phase sequence direction of bypass voltage is reversed. Normally, the phase of Phase B lags 120 degrees behind Phase A, and the phase of Phase C lags 120 degrees behind Phase B. Verify that the phase rotation of the bypass supply presented to the UPS is correct, and rectify it if it is wrong. Contact Vertiv Services at 800-543-2378 for assistance.
Load Impact Transfer	A transfer to bypass occurred due to a large step load. The UPS should recover automatically. Turn On connected equipment in sequential order to reduce the step loading of the inverter.
Transfer Timeout	The load is on bypass power due to excessive number of transfers that occurred within the last hour. The UPS will recover automatically and will transfer the load back to inverter power within an hour.
Load Sharing Fault	UPS working within a parallel system are not sharing load current correctly. Contact Vertiv Services at 800-543-2378 for assistance.
DC Bus Abnormal	Shut off inverter due to abnormal DC bus voltage. Contact Vertiv Services at 800-543-2378 for assistance.
System Transfer	The whole paralleled UPS system transferred to bypass at the same time. This message will appear on the UPS which passive transfer to bypass.
DC Bus Overvoltage	Rectifier, inverter and battery converter were shutdown because DC bus voltage is too high. Check whether there is a fault in rectifier side. If no, then check whether overload occurs. Restart the inverter after resetting the fault. If fault does not clear, contact Vertiv Services at 800-543-2378 for assistance.
LBS Active	The LBS setting is active. The UPS is acting as an LBS master or slave in a dual bus configuration.
Battery ground fault	Battery ground fault from dry contact signal. Contact Vertiv Services at 800-543-2378 for assistance.
Inverter turned On manually	Manual turn On via front panel
Inverter turned Off manually	Manual turn Off via front panel
EPO	Emergency power off
Transfer Confirm	Interrupted transfer confirm
Transfer Cancel	Interrupted transfer is cancel
Unit Off Confirm	Unit turned off confirm
System Off Confirm	System turned off confirm
Fault Reset	Fault reset
Alarm Silence	Alarm silence
Turn On Fail	Turn on fail
Alarm Reset	Audible alarm reset
Load on Bypass	UPS load is supplied by the bypass
Load on Inverter	UPS load is supplied by the inverter
Load on Battery	UPS load is supplied by the battery
Output Disabled	UPS output disabled
Maint. Disconnect Closed	Maintenance disconnect closed
Reserved	—
Output Disconnect Open	Output disconnect open
Battery Reverse	Connect the battery again and check the wiring of batteries.
No Battery	Check the battery and the wiring of batteries.
Auto start	After UPS was shutdown at EOD, inverter auto starts when utility is restored.
BCB closed	BCB closed from dry contact signal.
BCB open	BCB open from dry contact signal.
Battery Float Charging	Battery is float charging.

Table 31 UPS status messages (continued)

Event Message	Description / Suggested Action (if any)
Battery Boost Charging	Battery is boost charging.
Battery Discharging	Battery is discharging.
Battery Period Testing	Battery is period self-testing.
Batt. Capacity Testing	Battery is capacity self-testing.
Batt. Maint. Testing	Battery is maintenance self-testing.
Inverter in Setting	Inverter is in parameter setting.
Rectifier in Setting	Rectifier is in parameter setting.
Batt. Converter Fault	Battery converter output voltage beyond limits or battery fuse failed. Battery converter shuts down. Battery backup not available.
Operation Invalid	This record is registered following an incorrect operation.
Byp. Abnormal Shutdown	Both bypass and inverter voltages unavailable. Load interruption.
Mains Neutral Lost	AC input mains reference neutral not detected.
Battery Room Alarm	Environment in battery room needs attention.
Rec Flash Update	Rectifier firmware is being updated.
Inv Flash Update	Inverter firmware is being updated.
Monitor Flash Update	Monitor firmware is being updated.
LBS abnormal	LBS is abnormal.





Vertiv.com | Vertiv™ Headquarters, 1050 Dearborn Drive, Columbus, OH, 43085, USA

© 2020 Vertiv™ All rights reserved. Vertiv™ and the Vertiv™ logo are trademarks or registered trademarks of Vertiv™. All other names and logos referred to are trade names, trademarks or registered trademarks of their respective owners. While every precaution has been taken to ensure accuracy and completeness herein, Vertiv™ assumes no responsibility, and disclaims all liability, for damages resulting from use of this information or for any errors or omissions. Specifications are subject to change without notice.

SL-25648_REV11-02-20