



BY JOHNSON CONTROLS

AIR HANDLING UNITS

OPERATION AND MAINTENANCE

New Release

Form 102.20-OM2 (615)



LD09624

INDOOR SOLUTION XT AHU



LD17323

OUTDOOR SOLUTION XT AHU

Renewal Parts
With P/N contact Balt. Parts
(800) 932-1701
Manufactured or specialty
parts, contact Airside Technical
Services (800) 545-7814



LD13282

YORK CUSTOM AHU

Issue Date:
June 1, 2015



IMPORTANT!

READ BEFORE PROCEEDING!

GENERAL SAFETY GUIDELINES

This equipment is a relatively complicated apparatus. During rigging, installation, operation, maintenance, or service, individuals may be exposed to certain components or conditions including, but not limited to: heavy objects, refrigerants, materials under pressure, rotating components, and both high and low voltage. Each of these items has the potential, if misused or handled improperly, to cause bodily injury or death. It is the obligation and responsibility of rigging, installation, and operating/service personnel to identify and recognize these inherent hazards, protect themselves, and proceed safely in completing their tasks. Failure to comply with any of these requirements could result in serious damage to the equipment and the property in

which it is situated, as well as severe personal injury or death to themselves and people at the site.

This document is intended for use by owner-authorized rigging, installation, and operating/service personnel. It is expected that these individuals possess independent training that will enable them to perform their assigned tasks properly and safely. It is essential that, prior to performing any task on this equipment, this individual shall have read and understood the on-product labels, this document, and any referenced materials. This individual shall also be familiar with and comply with all applicable industry and governmental standards and regulations pertaining to the task in question.

SAFETY SYMBOLS

The following symbols are used in this document to alert the reader to specific situations:



Indicates a possible hazardous situation which will result in death or serious injury if proper care is not taken.



Identifies a hazard which could lead to damage to the machine, damage to other equipment and/or environmental pollution if proper care is not taken or instructions are not followed.



Indicates a potentially hazardous situation which will result in possible injuries or damage to equipment if proper care is not taken.

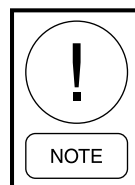

Highlights additional information useful to the technician in completing the work being performed properly.



External wiring, unless specified as an optional connection in the manufacturer's product line, is not to be connected inside the control cabinet. Devices such as relays, switches, transducers and controls and any external wiring must not be installed inside the micro panel. All wiring must be in accordance with Johnson Controls' published specifications and must be performed only by a qualified electrician. Johnson Controls will NOT be responsible for damage/problems resulting from improper connections to the controls or application of improper control signals. Failure to follow this warning will void the manufacturer's warranty and cause serious damage to property or personal injury.

CHANGEABILITY OF THIS DOCUMENT

In complying with Johnson Controls' policy for continuous product improvement, the information contained in this document is subject to change without notice. Johnson Controls makes no commitment to update or provide current information automatically to the manual or product owner. Updated manuals, if applicable, can be obtained by contacting the nearest Johnson Controls Service office or accessing the Johnson Controls QuickLIT website at <http://cgproducts.johnsoncontrols.com>.

It is the responsibility of rigging, installation, and operating/service personnel to verify the applicability of these documents to the equipment. If there is any ques-

tion regarding the applicability of these documents, rigging, lifting, and operating/service personnel should verify whether the equipment has been modified and if current literature is available from the owner of the equipment prior to performing any work on the unit.

CHANGE BARS

Revisions made to this document are indicated with a line along the left or right hand column in the area the revision was made. These revisions are to technical information and any other changes in spelling, grammar or formatting are not included.

ASSOCIATED LITERATURE

MANUAL DESCRIPTION	FORM NUMBER
Solution XT Air Handling Units Installation and Assembly	102.20-N1
York Custom Air Handling Units Installation and Assembly	102.20-N3
Steps to Protect New Equipment Warranty	102.20-CL1
Air Handling Units Start-up Checklist	100.00-CL1
Long-Term Storage Requirement - Field Preparation - Air Handling Units	50.20-NM3
Long-Term Storage Periodic Checklist and Logs - Air Handling Units	50.20-CL3
Limited Warranty	50.05-NM2
Electric Motor Warranty	50.05-NM2.2
Air Cooled Condensing Unit DX Coil Split System Applications and Piping Guidelines	50.40-ES3
Air Modulator Service & Warranty Procedure	SI0262

SOLUTION XT UNIT MODEL NOMENCLATURE

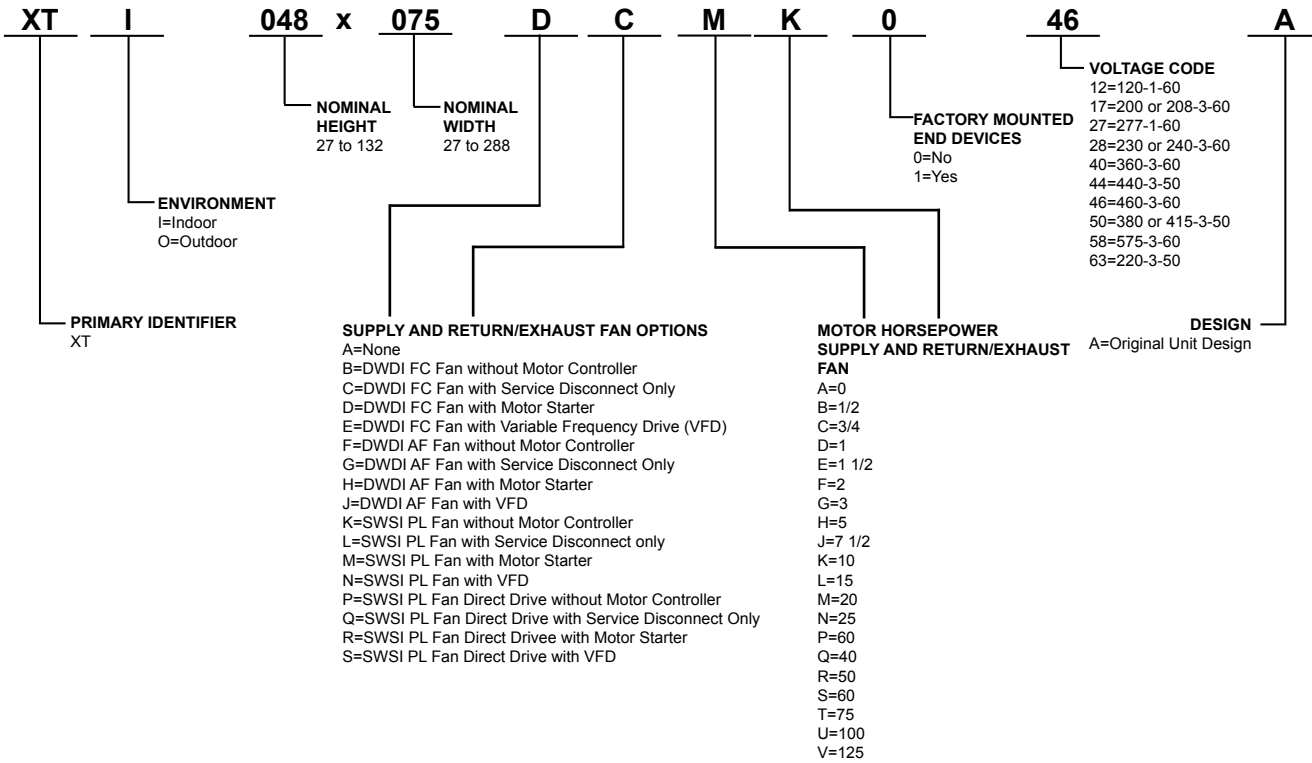

Note: The terms *skid* and *section* have the same meaning in this document; Variable Speed Drive (VSD) and Variable Frequency Drive (VFD) do as well.

TABLE OF CONTENTS

SECTION 1 - GENERAL INFORMATION AND SAFETY.....	13
Introduction.....	13
About This Manual.....	13
Warranty.....	13
Responsibility For Safety.....	13
SECTION 2 - START-UP AND OPERATION.....	15
Before Start-Up.....	15
Inspecting Fan Assembly.....	16
Inspecting Belts and Sheaves.....	17
Checking Isolators.....	17
Start-Up.....	19
Checking Operation of Fans.....	19
Checking Operation of Dampers.....	19
Energize Fan Motors.....	29
Variable Frequency Drive (VFD).....	29
Check Doors And Latches.....	29
Energy Recovery Wheel.....	29
Indirect Fired Gas Heat Start Up.....	34
Starting the Electric Heater.....	46
Operation.....	50
Test And Balance.....	50
Setting Limits.....	50
Checking Motors, Belts and Sheaves.....	51
P-Cone®.....	51
SECTION 3 - MAINTENANCE.....	53
General Requirements.....	53
Inspect Parts.....	54
Cabinet.....	54
Door Hardware and Gaskets.....	54
Panels.....	54
Hoods and Louvers.....	54
Bird Screens.....	54
Optional Moisture Eliminators.....	54
Outdoor Air Hood.....	54
Fan Segment (Supply, Return or Exhaust).....	55
Removing the Fan.....	55
Checking the Fan.....	55
Operating Adjustable Motor Base.....	55
Standard.....	55
Checking Belt Tension.....	57
Aligning Sheaves.....	57
Using a Straightedge.....	58
Using a String.....	58
Belt Replacement Tensioning and Sheave Alignment for Top Mount.....	58
Lubrication.....	60
Fan Bearing Lubrication.....	61

TABLE OF CONTENTS (CONT'D)

Checking Condition of Extended Lubrication Lines	61
Recommended Lubricant for Bearings	61
Proper Interval and Quantity	61
Lubricating the Fan Segment and Motor	62
Checking Condition of Mounting Hardware, Adjustable Motor Base and Motor	63
Checking Electrical Connections	63
Keep Motor Bearing Lubricated	63
UVC Emitter Lamps	64
Three Types of Lamps	65
Maintaining and Replacing Filter Segments	65
Replacing the Filters	66
Economizer Segment (Dampers)	66
Cleaning Procedure	66
Hardware Check	66
Coil Segment Cleaning	66
Tools, Equipment and Materials	66
Cleaning Procedure	67
Condensate Drain Pan, Trap and Line Cleaning	67
Tools, Equipment and Materials	67
Schedule and Conditions	67
Cleaning Procedure	68
Coil Freeze Protection	68
Energy Recovery Wheel	68
Airxchange®	68
Tools and Materials	68
Cleaning the Wheel	69
Adjusting Air Seals	69
Inspect Wheel Drive Components	70
NovelAire® Technologies	70
Cleaning the Wheel	70
Adjusting Air Seals	71
Inspect Wheel Drive Components	71
How to Measure, Assemble and Install	71
Thermotech®	72
Cleaning the Wheel	72
Adjusting Air Seals	72
Inspect Wheel Drive Components	73
Innergy Tech®	73
Cleaning the Wheel	73
Adjusting Air Seals	73
Inspect Wheel Drive Components	74
ECONO-DISK®	75
Maintenance Instructions	75
P-Cone®	75
Maintenance of P-Cone®	75

TABLE OF CONTENTS (CONT'D)

SECTION 4 - SERVICE AND REPAIR	77
Service Tools and Equipment.....	77
Service Information	78
Troubleshooting.....	78
Pitot Tube	78
Inclined Manometer.....	79
Filter Gauge.....	79
U-Tube Manometer	79
Duct Pressures.....	80
Velocity	80
Static Pressure	81
Total Pressure	81
Requesting Assistance	81
Adjusting, Removing, and Installing Sheaves	82
Fixed Pitch Sheaves (T.B Woods With Sure Grip Bushings)	82
Adjustable Pitch Sheaves (T.B. Woods - Model JVS)	84
Adjustable Pitch Sheaves (T.B. Woods - Model FHP).....	85
SECTION 5 - WIRING DIAGRAMS	87
Installing Kit (If Applicable)	92
APPENDIX A – START-UP CHECKLIST	107
APPENDIX B – LONG-TERM STORAGE	111
Temperature	116

LIST OF FIGURES

FIGURE 1 - Solution XT Seismic Isolator.....	15
FIGURE 2 - Example of a Solution XT Termination Chart.....	16
FIGURE 3 - Fan and Motor Isolator Support Frame.....	17
FIGURE 4 - Spring Isolator.....	17
FIGURE 5 - Spring Isolator Set-Up	18
FIGURE 6 - Counterbalance Locked into Place for Shipping.....	19
FIGURE 7 - Counterbalance Unlocked for Start-Up.....	19
FIGURE 8 - Front of a 2X2 Fan Array	20
FIGURE 9 - Back of a 2X2 Fan Array.....	20
FIGURE 10 - Front of a 1X2 Fan Array	20
FIGURE 11 - High And Low Connections for an In Fan Air Monitoring System	23
FIGURE 12 - High And Low Connections and Associated Tubing for Fan Mounted Air Monitoring System.....	24
FIGURE 13 - Port Locations for Fan Mounted Air Monitoring System	24
FIGURE 14 - Ductwork Inlet Requirements.....	25
FIGURE 15 - Ductwork Radius.....	25
FIGURE 16 - 25% Sensing Option.....	25
FIGURE 17 - 25%/75% Sensing Option.....	25
FIGURE 18 - 25%/75% Sensing Option.....	26
FIGURE 19 - Example of Sweep Balance Results Label On Fan Housing.....	29
FIGURE 20 - Metal Spacers on Solution XT Doors.....	29
FIGURE 21 - Vertical Wheel for Indoor AHU.....	29
FIGURE 22 - Horizontal Wheel for Outdoor AHU.....	30
FIGURE 23 - Energy Recovery Wheel - Pulley Side.....	31
FIGURE 24 - Segment Retainer.....	32
FIGURE 25 - Diameter Seal Adjustment	32
FIGURE 26 - Purge Angle Detail.....	33
FIGURE 27 - Purge Angle Detail.....	34
FIGURE 28 - Gas Furnace Condensate Drain Trap.....	36
FIGURE 29 - Open Fuse Disconnects	37
FIGURE 30 - Set Id Fan Damper	37
FIGURE 31 - Check Main Gas Supply Pressure.....	37
FIGURE 32 - Draft Over Fire Test Port.....	38
FIGURE 33 - Flue Combustion Temperature and Efficiency Test Port- ID Blower	38
FIGURE 34 - Damper Actuator.....	38
FIGURE 35 - Example Solution XT Gas Furnace Fuel Venting System	43
FIGURE 36 - Typical Wiring Diagram.....	44
FIGURE 37 - Minimum Air Velocity Required for Safe Operation.....	48
FIGURE 38 - Pressure Probe Direction.....	49
FIGURE 39 - Air Flow Switch Connections	49
FIGURE 40 - V-Belt Drive Kit Label.....	51
FIGURE 41 - Remove Mist Eliminator.....	54
FIGURE 42 - Weather Hood Installation	54
FIGURE 43 - Typical Drive Kit Data Tag.....	55
FIGURE 44 - Solution XT Adjustable Motor Base	55
FIGURE 45 - Solution XT Adjustable Motor Base (Top Mount).....	56
FIGURE 46 - Belt Tensioning	57
FIGURE 47 - Belt Tensioning Gauge.....	57

LIST OF FIGURES (CONT'D)

FIGURE 48 - Alignment Using Straight Edge	58
FIGURE 49 - Alignment Using String	58
FIGURE 50 - Sheave Angular Misalignment	59
FIGURE 51 - Motor Base Lowered.....	59
FIGURE 52 - Sheave Angular Alignment.....	59
FIGURE 53 - Sheave Angular Misalignment	60
FIGURE 54 - Sealed Bearing	60
FIGURE 55 - Bearing with Set Screw Type Locking Device	60
FIGURE 56 - Bearing with Eccentric Cam.....	60
FIGURE 57 - Split Bearing (Assembled)	61
FIGURE 58 - Optional Lubrication Lines	61
FIGURE 59 - Open Drip Proof (ODP) Motor	63
FIGURE 60 - Totally Enclosed Fan Cooled (TEFC) Motor	63
FIGURE 61 - UV Lamps	65
FIGURE 62 - Installing V-Mod Lamp	65
FIGURE 63 - Installing V-Ray and V-Max Grid Lamps	65
FIGURE 64 - V-Max Grid Lamps	65
FIGURE 65 - Typical Filter Types	65
FIGURE 66 - Installing Angle Filters.....	66
FIGURE 67 - Installing Side Load Filters.....	66
FIGURE 68 - Rinse Segments	69
FIGURE 69 - Diameter Seal Adjustment	69
FIGURE 70 - Airxchange® Energy Recovery Wheel With Bearing Support Beam Side	70
FIGURE 71 - How to Measure.....	71
FIGURE 72 - Disassembly	71
FIGURE 73 - Assembly	71
FIGURE 74 - Installation.....	72
FIGURE 75 - Loosen Screws Before Adjusting Seals	72
FIGURE 76 - ERW Seal Locations.....	73
FIGURE 77 - Airloop™ Labyrinth Seal Adjustment	74
FIGURE 78 - Plenum Fan Tap Location and Connection Illustration	75
FIGURE 79 - Maintenance Requirements.....	76
FIGURE 80 - Construction of Pitot Tube	78
FIGURE 81 - Pitot Tube.....	78
FIGURE 84 - Magnehelic Filter Guage.....	79
FIGURE 82 - Inclined Manometer	79
FIGURE 83 - Minihelic Filter Gauge.....	79
FIGURE 85 - U-Tube Manometers	80
FIGURE 86 - Slack Tube Manometer.....	80
FIGURE 87 - Static Pressure Air System	81
FIGURE 88 - Inserting Cap Screws.....	82
FIGURE 89 - Standard Mounting	82
FIGURE 90 - Reverse Mounting.....	83
FIGURE 91 - Adjustable Pitch Sheave (JVS).....	84
FIGURE 92 - Adjustable Pitch Sheave (FHP)	85
FIGURE 93 - Full Voltage Starter	88
FIGURE 94 - Full Voltage Starter With Single Point Power Connection (204195).....	90

LIST OF FIGURES (CONT'D)

FIGURE 95 - Outside Air Damper Kit (Relay Installation)	92
FIGURE 96 - Solution XT Termination Chart Inside Enclosure Door	93
FIGURE 97 - Typical FPC Wiring Diagram.....	94
FIGURE 98 - Transformer Enclosure Wiring Detail (Shown Open).....	96
FIGURE 99 - Transformer Wiring Diagram.....	97
FIGURE 100 - UV Control Panel Wiring (8 amps).....	99
FIGURE 101 - UV Control Panel Wiring (greater than 8 amps)	100
FIGURE 102 - Gas Heat, Single Phase, 1500Va Transformer Wiring Diagram	102
FIGURE 103 - Gas Heat, Three Phase, 1000Va Transformer Wiring Diagram.....	103
FIGURE 104 - Gas Heat, Three Phase, 500Va Transformer Wiring Diagram.....	104
FIGURE 105 - Typical Wiring Diagram for Electric Heat Control Type Vermier	105
FIGURE 106 - Typical Wiring Diagram for Control Type Full SCR.....	106

LIST OF TABLES

TABLE 1 - Torque for Tightening Set Screws.....	16
TABLE 2 - Air Measuring Device Connections.....	21
TABLE 3 - Indoor Unit Example	27
TABLE 4 - Outdoor Unit Example	28
TABLE 5 - Gas Heat Segment Model Number Nomenclature	39
TABLE 6 - Natural Gas Pressure Requirements (Inches Wc)	40
TABLE 7 - Natural Gas Pressure Requirements (Inches Wc)	41
TABLE 8 - Inlet Size (NPT)	42
TABLE 9 - Burner Temperature Rise	45
TABLE 10 - Maximum Current for 75°C Copper Wire.....	47
TABLE 11 - Minimum / Maintenance Requirements According to ASHRAE.....	53
TABLE 12 - Fan Bearing Re-Lubrication Intervals for Ball Bearing Pillow Blocks	62
TABLE 13 - Fan Bearing Lubrication Intervals for Spherical Roller Bearing Solid Pillow Blocks.....	62
TABLE 14 - Fan Bearing Lubrication Intervals for Spherical Roller Bearing Split Pillow Blocks.....	62
TABLE 15 - Fan Bearing Lubrication Intervals for Dodge ISN Bearings.....	62
TABLE 16 - Motor Bearing Lubrication Intervals.....	64
TABLE 17 - Motor Bearing Service Conditions	64
TABLE 18 - Motor Bearing Lubrication Interval Multiplier	64
TABLE 19 - Cap Screw Torque Values	83
TABLE 20 - Set Screw Torque Values.....	83
TABLE 21 - SI Metric Conversion	116

SERVICE TASK REFERENCE

Adjustable Motor Base	
Operation	55
Air Louvers	
Inspection	54
Air Modulator	
Start-Up	29
Belts	
Checking Tension	58
Bird Screen	
Inspection	54
Cabinet Maintenance	
Cleaning	54
Coils	
Cleaning	66
Controls	
Control Wiring	94
Dampers	
Checking Operation	19
Blade Orientation	28
Cleaning	66
Hardware Check	66
Damper Actuator	
Installation	28
Direct Coupled Mounting	28
Doors	
Start-Up Inspection	29
Drain Lines	
Cleaning	67
Freeze Protection	68
Drain Pan	
Field Testing	67
Freeze Protection	68
Drain Trap	
Cleaning	67
Freeze Protection	68
Drive Kit	
Inspection	55
Electric Heat	
Control Wiring	105

Energy Recovery Wheel	
Control Wiring	29
Start-Up	32
External Lube Lines	61
Fan Assembly	
Pre Start-Up Inspection	16
Cleaning	55
Maintenance Inspection	55
Fan Bearing	
Types	60
Lubrication	61
Fan Motor	
Energizing at Start-up	28
Inspection and Maintenance	62
Bearing Lubrication	63
Fan	
Cleaning	55
Inspection	55
Gas Heat	
Control Wiring	44
Filters (AF, FF, RF)	
Types	65
Maintenance And Replacement	65
Inserting into Side Load Filter Tracks	66
Motors	
Check Amperage after Air Balancing	51
Sheaves	
Replacing after Air Balancing	51
Alignment	57
Start-up	
Start-Up Checklist	19
Test and Balance	
Air Balance	50
Dynamic Balance	50
Variable Frequency Drive (VFD)	
Set-Up of Non Factory Mounted VFD	29

SECTION 1 - GENERAL INFORMATION AND SAFETY

INTRODUCTION

The YORK air handling unit (AHU) is manufactured to the highest design and construction standards to ensure high performance, reliability and adaptability to all types of air handling installations.

ABOUT THIS MANUAL

This manual and any other document supplied with the AHU are the property of Johnson Controls, which reserves all rights. This manual may not be reproduced, in whole or in part, without prior written authorization from an authorized Johnson Controls representative.

In addition, this manual:

- Includes suggested best working practices and procedures, which are issued for guidance only, and they do not take precedence over the above stated individual responsibility and/or local safety regulations.
- Contains all the information required for correct installation and commissioning of the AHU, together with operating and maintenance instructions.
- Should be read thoroughly before attempting to operate or service the AHU.
- Contains detailed procedures, including installation, commissioning and maintenance tasks that must only be performed by suitably trained and qualified personnel.

The manufacturer will not be liable for any injury or damage caused by incorrect installation, commissioning, operation, or maintenance resulting from a failure to follow the procedures and instructions detailed in the manual.

WARRANTY

Johnson Controls warrants YORK AHUs in accordance with the limited warranty engineered systems equipment procedure. Refer to the *Air Side Limited Warranty and Limited Warranty (Form 50.05-NM2)* for more information.

Johnson Controls warrants all equipment and materials against defects in workmanship and materials for a period of 18 months from the date of shipment or 12 months from the date of start-up, whichever comes first, unless labor or extended warranty has been purchased as part of the contract.

The warranty is limited to parts only replacement and shipping of any faulty part or subassembly, which has failed due to defects in workmanship and materials. All claims must be supported by evidence that the failure has occurred within the warranty period, and that the AHU was operated within the designed parameters specified.

All warranty claims must specify the AHU model, serial number, order number, and run hours/starts. Model and serial number information is printed on the AHU identification plate.

The AHU warranty will be void if any modification to the AHU is carried out without prior written approval from Johnson Controls. For warranty purposes, the following conditions must be satisfied:

- Only genuine YORK approved spare parts must be used.
- All of the scheduled maintenance operations detailed in this manual must be performed at the specified times by suitably trained and qualified personnel.
- Failure to satisfy any of these conditions will automatically void the warranty. Refer to *Air Side Limited Warranty and Limited Warranty (Form 50.05-NM2)* for details.

RESPONSIBILITY FOR SAFETY

Every care has been taken in the design and manufacture of the AHU to ensure compliance with the safety requirements. However, the individual operating or working on any equipment is primarily responsible for:

- Personal safety, safety of other personnel, and the equipment.
- Correct utilization of the equipment in accordance with the procedures detailed in this manual.

THIS PAGE INTENTIONALLY LEFT BLANK.

SECTION 2 - START-UP AND OPERATION

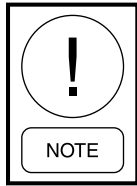

Never use silicone caulk/sealant or caulk/sealant containing silicone in or on any air handling equipment.

BEFORE START-UP

Perform a general inspection. Identify and perform the appropriate the lock out/tag out and safety rules. Refer to the *AHU Start-up Checklist, (Form 100.00.CL1)* provided with the information package shipped with the AHU.

For more information about the steps below, refer to the *Solution XT - Installation and Assembly Manual (Form 102.20-N1)* and *Custom AHU - Installation and Assembly Manual (Form 102.20-N3)*. For an AHU equipped with a Variable Frequency Drive (VFD), refer to the specific VFD literature for additional start-up requirements.

- Check for damage to the AHU's interior and exterior.
- Ensure the terminal screws and wiring connections are secure in the control, electric and air modulator panels.
- Verify that the:
 - Equipment was received as ordered.
 - AHU was installed on flat and level surface and with proper clearances.
 - Air hoods are installed properly.
 - Condensate drains are properly trapped.
 - All wiring and tubing connections are complete at shipping splits.
 - All field piping connections are completed.
 - All shipped loose parts are installed.
 - All ductwork is complete and available for full airflow.
 - Installer removed all dirt, debris, hardware, mold, etc. from interior of the AHU and its ducts.
 - Filter gauge is set to zero.

- All shipping splits are sealed and secured properly.
- For outdoor AHUs, Pipe chase floor is sealed at penetrations.
- All shipping bolts and other materials were removed.
- Visually inspect the roof curb for tight seal around the outdoor AHU.
- Ensure clean air filters are installed and secured properly.
- Inspect all field provided wiring completely.
- Do not remove the functional bolts from the seismic isolators as shown in *Figure 1 on page 15*.

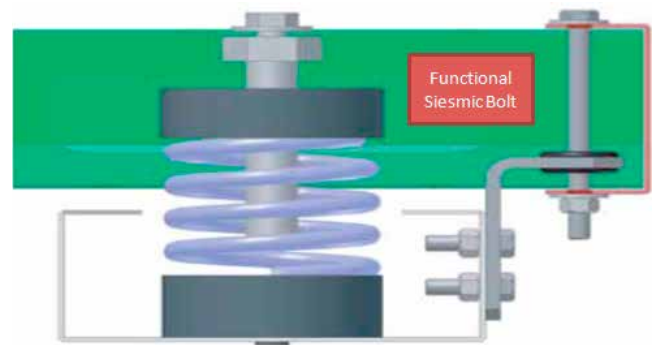

LD09636a

FIGURE 1 - SOLUTION XT SEISMIC ISOLATOR

- Ensure the damper linkage is tight and is in the correct power *off* position.
- If the return air dampers are closed, loosen the actuator or crank arm on the jackshaft, open the dampers, and retighten the actuator or crank arm.
- Verify the following controls installation are complete:
 - Contractor Furnished Controls - Controls contractor is responsible for safe and proper control of the AHU.
 - Factory Furnished Controls - Refer to the Factory Engineered Controls/Factory Packaged Controls (FEC/FPC).
- Make sure the termination chart is attached to the inside of the control enclosure door as shown in *Figure 2 on page 16*.



Johnson Controls

YORK Solution XT

MODEL #		COM: 166473	
XTO-096X096-QSKH146A			
SERIAL # / DATE CODE		JOB IDENTIFICATION #	
CAAM XT0081		2E-330086-02	
SEGMENT IDENTIFICATION			
(DP-FS-XA-CC-HM-HC-RF-EE-XA-FR-IP)			
I/O Wiring		UNIT TAG #	
RTU-2A			

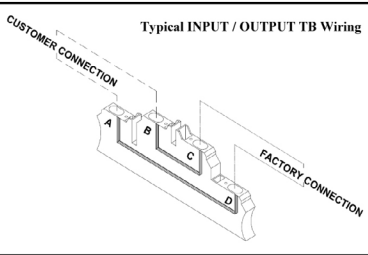

Typical INPUT / OUTPUT TB Wiring

Point	Module	Home Run	I/O Pair	Power	Red	Black	Note
HP-S	FEC2611	-		-	IN5	ICOM5	21 & 22 on CR4
CLG-W	FEC2611	1	1	1	OUT5	OCOM5	
PH-W	FEC2611	1	2	1	OUT7	OCOM7	
MA-T	FEC2611	1	6	-	IN3	ICOM3	
RA-T	FEC2611	1	8	-	IN2	ICOM2	
RF-O	FEC2611	2	1	-	OUT4	OCOM4	Jumper OCOM# to 24V COM
RF-C	FEC2611	2	2	-	OUT2	OCOM2	
RF-S_DP	FEC2611	2	3		IN8	ICOM8	
DA-T	FEC2611	3	1	-	IN1	ICOM1	
SF-S_DP	FEC2611	DIRECT	1	-	IN7	ICOM7	
SF-O	FEC2611	DIRECT	2	-	OUT9	OCOM9	
SF-C	FEC2611	DIRECT	3	-	OUT1	OCOM1	
LT-S	IOM2721(4)	-		-	IN1	ICOM1	21 & 22 on CR3
PH-T	IOM2721(4)	1	4	-	IN3	ICOM3	
PFILT-A	IOM2721(4)	1	5	-	IN2	ICOM2	
RA-H	IOM2721(4)	1	7	1	IN4	ICOM4	
LT-A	TB	1	3	-	2023 D	2023 C	
SDR-2	TB	2	4	-	4055 D	4055 C	
HP-A	TB	3	2	-	2041 C	2041 D	
SDR-1	TB	DIRECT	4	-	4054 D	4054 C	

PreTest: _____ Final Test: _____

LD16563b

FIGURE 2 - EXAMPLE OF A SOLUTION XT TERMINATION CHART

Inspecting Fan Assembly

Use the following instructions to inspect the fan assembly.

1. When the AHU is removed from long term storage, purge the moisture-laden bearing grease, and replenish the AHU with fresh grease, according to the lubrication label.
2. Meg the motor to verify that the resistance is at a satisfactory level, compared to the value recorded prior to storage.
3. Check the torque for bearings and locking collars as shown in *Table 1 on page 16*.

TABLE 1 - TORQUE FOR TIGHTENING SET SCREWS

SETSCREW DIAMETER (IN)	HEX SIZE ACROSS FLATS (IN)	MINIMUM RECOMMENDED TORQUE	
		IN LB	FT LB
1/4	1/8	66 - 85	5.5 - 7.08
5/16	5/32	126 - 164	10.5 - 13.7
3/8	3/16	228 - 296	19.0 - 24.7
7/16	7/32	348 - 452	29.0 - 35.7
1/2	1/4	504 - 655	42.0 - 54.6
5/8	5/16	1104 - 1435	92.0 - 119.6

4. Verify that the fan wheel is properly aligned, is tight on the shaft, and moves freely.
5. Make sure the fan bearings are properly lubricated. Refer to *SECTION 3 - MAINTENANCE* in this manual for more information.

- On Solution units, verify that the tie down bolts are removed from the four corners of the fan base assembly as shown in *Figure 3 on page 17*. For small AHUs, the tie down bolts may only be applied to three corners of the fan base since one corner is not accessible.

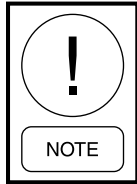

Do not remove the shipping bolts if there are no springs.

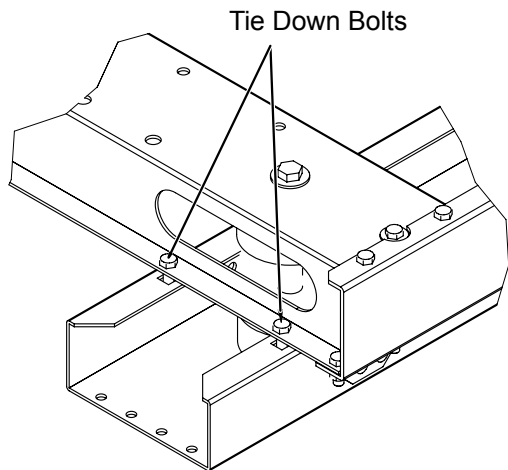

FIGURE 3 - FAN AND MOTOR ISOLATOR SUPPORT FRAME

Inspecting Belts and Sheaves

- Verify that the sheaves are properly aligned and tight on the shaft. Improper sheave alignment and belt tension are potential causes of excessive noise and vibration, and shortened belt and bearing life. Refer to *SECTION 3 - MAINTENANCE* in this manual for more information.
- Check the belt tension. If not familiar with the process, refer to *SECTION 3 - MAINTENANCE* in this manual. It is normal for belts to loosen after start-up. The new belts will run in or take a set by seating slightly deeper into the grooves of the sheaves. Recheck the tension after one day, and three days.
- Make sure the motor mounting bolts and adjustable motor base bolts are tight.

Checking Isolators

Solution XT Isolators

Check the fan base isolators and thrust restraints for proper adjustment.

- Standard fan isolation consists of spring isolators as shown in *Figure 4 on page 17* mounted under the internal fan assembly.
- For thrust restraint adjustment procedures, if applicable, refer to the service manual.
- Prepare the fan isolators for operation, using the following instructions:
 - After removing the tie down bolts from the internal fan assembly, check the blower/motor frame for the correct height, and that the frame is level.
 - To adjust the isolators as shown in *Figure 4 on page 17*,
 - Loosen the cap screws on top of the adjustment bolt.
 - Turn the adjusting bolt.
 - Check the operational height and level of the frame. Repeat this procedure until the height and frame are level.
 - Tighten the cap screws. Refer to the service manual for additional instructions.

- Verify the fan is aligned with the AHU discharge.
- Readjust the isolators as necessary.

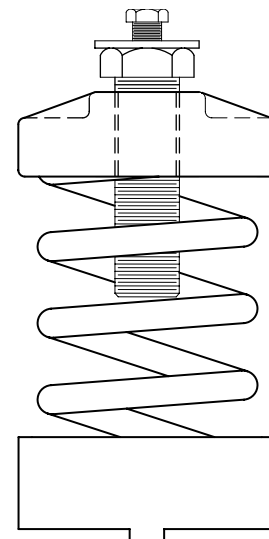

FIGURE 4 - SPRING ISOLATOR

Custom AHU Isolators

Fan Hold-Down/Spring Isolator Set-Up

All fans are internally spring isolated and will be bolted down for unit shipping. After unit is in place, assembled and leveled, Fan Hold-Down can be disassembled by removing two nuts and one washer from each side. Remove tubes from wire and discard wire.

Place tubes on studs, and place shoulder washer (shoulder up) on studs. Place one nut on each stud and tighten it on shoulder washer.

Place remaining nuts on studs, and tighten to lower nut to lock in place.

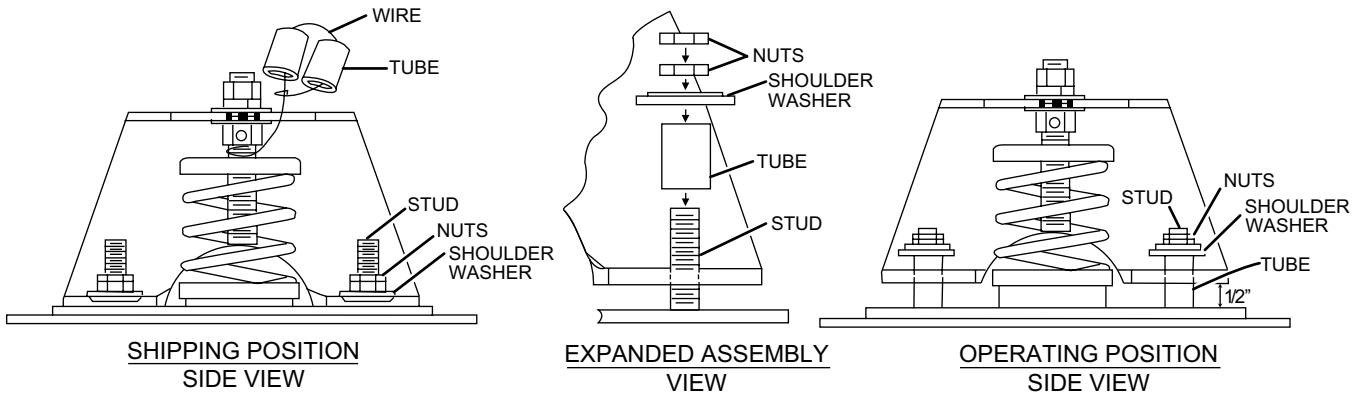

P-STYLE PLUG FAN

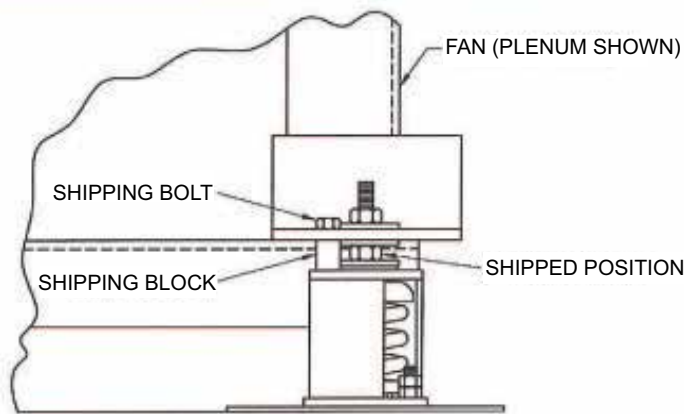

BUY-OUT ISOLATORS

1. Remove the 7/8 nut as shown in the operating position view.
2. Loosen the 7/8 jam nut between the isolator housing and the fan base support angle until the desired level is achieved.
3. Repeat step two until all isolators are set at the proper elevation and the fan base is level.

FIGURE 5 - SPRING ISOLATOR SET-UP

START-UP



Do not be operate this AHU until after start-up is completed as outlined in these instructions. Do not allow the AHU to run on unreliable temporary power, which could turn the AHU on/off periodically or rapidly, and to protect it from irregular voltages and surges.

It is recommended that the start-up technician use the *AHU Start-up Checklist (Form 100.00-CL1)*, included with the AHU, and record the gathered information in the appropriate fields. If there are questions, refer to *Table 11 on page 53* for inspection requirements.

Install the provided or temporary filter media prior to start-up to adequately protect the components in the air stream and duct system.

If the AHU is equipped with an energy recovery wheel, rotate the wheel when the AHU is in service to prevent clogging.

Checking Operation of Fans

Check of the operation of the fans by:

1. Verifying the correct voltage, phase and cycles.
2. Energizing the power to the AHU disconnect switch.
3. Energizing the fan motor(s), briefly (bump) and check for correct fan rotation.

If the fan rotation is incorrect:

1. On three-phase equipment, reverse any two motor leads at the load side of the last starter component.
2. On single-phase equipment, follow the wiring diagram on the motor housing or on the inside of the motor terminal box.
3. Recheck for correct fan rotation.

Checking Operation of Dampers



Most units are shipped with dampers in closed position. Release and adjustment is to be done by field technician only

Make sure the AHU will not operate with all dampers closed.

Linkage design and/or damper linkage is optional. Air-flow control dampers may be operated with pneumatic or electric actuator/controllers.

Prior to occupancy, test the ventilation system to ensure that the outdoor air dampers operate properly in accordance with the system design.

Back Draft Dampers for Dual Fans and Fan Arrays

The counterbalance is locked into place for shipping as shown in *Figure 6 on page 19*. Before startup, the counterbalance will have to be released. To do this, loosen the set screws and slide the counterbalance off the end of the shaft. Flip the counterbalance and slide it back on the shaft. Rotate the counterbalance above the damper as shown in *Figure 7 on page 19*, and then tighten the set screws. The counterbalance should be free to rotate.



FIGURE 6 - COUNTERBALANCE LOCKED INTO PLACE FOR SHIPPING



FIGURE 7 - COUNTERBALANCE UNLOCKED FOR START-UP

Examples of Fan Arrays



LD17226

FIGURE 8 - FRONT OF A 2X2 FAN ARRAY



LD17227

FIGURE 9 - BACK OF A 2X2 FAN ARRAY



LD17230

FIGURE 10 - FRONT OF A 1X2 FAN ARRAY

Airflow Control Dampers

Many combinations of damper sizes are available to control the flow. Mixing the return and outside air in the AHU's air inlet section may be supplied as follows:

- 100% outside air, 100% return air.
- 100% outside air, 0% return air.
- 0% outside air, 100% return air.
- Economizer section - 100% outside air, 100% return air, 100% exhaust air or mixed air.

Check the dampers, actuators, controls and linkage prior to applying power to the operators, to make sure nothing will obstruct the operation of the dampers.

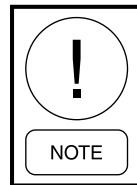

Do not overdrive the damper actuators because this may damage the dampers.

Exception: Actuators with over drive preset option.

Return air dampers may be closed for shipping. Loosen the actuator or crank arm on the jackshaft, open the dampers, and retighten the actuator or crank arm. The field is responsible for adjustments.

Air Measuring Device Connections

Calculating Flow Rate

For a Piezoring:
CFM = k * ΔP

ΔP = The differential in static pressure across the fan (inches w.g.)

k = See the table below

This assumes a standard air density of .075 lbs / cubic foot at sea level.

For a Cometer:
CFM = k * ΔPⁿ

ΔP = The differential in static pressure across the fan (inches w.g.)

k = See the table below

n = See the table below

This assumes a standard air density of .075 lbs / cubic foot at sea level.

TABLE 2 - AIR MEASURING DEVICE CONNECTIONS

FAN TYPE	FAN CLASS	FAN SIZE	k	n	FAN TYPE	FAN CLASS	FAN SIZE	k	n
ATLI	2	7x7	3675.20	0.5064	EPFN	1	122	944.92	N/A
ATLI	2	9x6	3919.00	0.5534	EPFN	2	122	944.92	N/A
ATLI	2	9x9	5510.60	0.4857	EPFN	3	122	944.92	N/A
ATLI	2	10x7	5556.20	0.4950	EPFN	1	150	1206.40	N/A
ATLI	2	10x10	5556.20	0.4950	EPFN	2	150	1206.40	N/A
ATLI	2	12x9	6789.70	0.4654	EPFN	3	150	1206.40	N/A
ATLI	2	12x12	8190.10	0.4887	EPFN	1	165	1518.58	N/A
ATLI	2	15x11	11065.00	0.4800	EPFN	2	165	1518.58	N/A
ATLI	2	15x15	11065.00	0.4800	EPFN	3	165	1518.58	N/A
ATLI	2	18x13	11610.00	0.4670	EPFN	1	182	1821.92	N/A
ATLI	2	18x18	13101.80	0.4754	EPFN	2	182	1821.92	N/A
ATLI	1	20x15	7013.10	N/A	EPFN	3	182	1821.92	N/A
ATLI	1	20x20	7300.00	N/A	EPFN	1	200	2185.80	N/A
ATLI	1	22x22	9081.90	N/A	EPFN	2	200	2185.80	N/A
ATLI	1	25x25	12030.00	N/A	EPFN	3	200	2185.80	N/A
ATLI	1	28x28	14450.00	N/A	EPFN	1	222	2713.93	N/A
ATLI	1	32x32	20400.00	N/A	EPFN	2	222	2713.93	N/A
ATLI	1	36x36	28049.90	N/A	EPFN	3	222	2713.93	N/A
ATLI	1	40x40	39236.40	N/A	EPFN	1	245	3285.02	N/A
ATLI	R	7x7	2200.70	0.4952	EPFN	2	245	3285.02	N/A
ATLI	R	9x6	2759.60	0.5155	EPFN	3	245	3285.02	N/A
ATLI	R	9x9	2805.50	0.4783	EPFN	1	270	3997.61	N/A
ATLI	R	10x7	4052.20	0.5091	EPFN	2	270	3997.61	N/A
ATLI	R	10x10	3862.70	0.4658	EPFN	3	270	3997.61	N/A
ATLI	R	12x9	5497.20	0.4996	EPFN	1	300	4945.21	N/A
ATLI	R	12x12	5477.90	0.4496	EPFN	2	300	4945.21	N/A
ATLI	R	15x11	7684.90	0.5195	EPFN	3	300	4945.21	N/A
ATLI	R	15x15	7684.90	0.5195	EPFN	1	330	5968.62	N/A
ATLI	R	18x13	14222.00	0.5236	EPFN	2	330	5968.62	N/A
ATLI	R	18x18	11510.00	0.4763	EPFN	3	330	5968.62	N/A
ATLI	2	20x15	6809.40	N/A	EPFN	1	365	7290.21	N/A
ATLI	2	20x20	7203.90	N/A	EPFN	2	365	7290.21	N/A
ATLI	2	22x22	8793.10	N/A	EPFN	3	365	7290.21	N/A
ATLI	2	25x25	11700.00	N/A	EPFN	1	402	8869.55	N/A
ATLI	2	28x28	14036.00	N/A	EPFN	2	402	8869.55	N/A
ATLI	2	32x32	2015.00	N/A	EPFN	3	402	8869.55	N/A
ATLI	2	36x36	27549.00	N/A	EPFN	1	445	10827.92	N/A
ATLI	2	40x40	38067.70	N/A	EPFN	2	445	10827.92	N/A
ATZAF	1	12x12	2337.50	N/A	EPFN	3	445	10827.92	N/A
ATZAF	2	12x12	2237.30	N/A	EPFN	1	490	13135.01	N/A
ATZAF	1	15x15	3873.60	N/A	EPFN	2	490	13135.01	N/A
ATZAF	2	15x15	3873.60	N/A	EPFN	3	490	13135.01	N/A
ATZAF	1	18x18	4675.00	N/A	EPFN	1	542	16111.75	N/A
ATZAF	2	18x18	4675.00	N/A	EPFN	2	542	16111.75	N/A

2

TABLE 2 - AIR MEASURING DEVICE CONNECTIONS (CONT'D)

FAN TYPE	FAN CLASS	FAN SIZE	k	n	FAN TYPE	FAN CLASS	FAN SIZE	k	n
ATZAF	1	20x20	5843.70	N/A	EPFN	3	542	16111.75	N/A
ATZAF	2	20x20	5301.10	N/A	EPLFN	2	122	944.92	N/A
ATZAF	1	22x22	7513.40	N/A	EPLFN	2	150	1206.40	N/A
ATZAF	2	22x22	6624.10	N/A	EPLFN	2	165	1518.58	N/A
ATZAF	1	25x25	9683.90	N/A	EPLFN	2	182	1821.92	N/A
ATZAF	2	25x25	9202.90	N/A	EPLFN	2	200	2185.80	N/A
ATZAF	1	28x28	12856.20	N/A	EPLFN	2	222	2713.93	N/A
ATZAF	2	28x28	11795.00	N/A	EPLFN	2	245	3285.02	N/A
ATZAF	1	32x32	16295.60	N/A	EPLFN	2	270	3997.61	N/A
ATZAF	2	32x32	16295.60	N/A	EPLFN	2	300	4945.21	N/A
ATZAF	1	36x36	19701.70	N/A	EPLFN	2	330	5968.62	N/A
ATZAF	2	36x36	19367.80	N/A	EPLFN	2	365	7290.21	N/A
ATZAF	1	40x40	23374.90	N/A	EPLFN	2	402	8869.55	N/A
ATZAF	1	40x40	25378.40	N/A	EPLFN	2	445	10827.92	N/A
ATZAF	2	40x40	22974.20	N/A	EPLFN	2	490	13135.01	N/A
ATZAF	2	40x40	25044.50	N/A	MPQN	1	122	944.92	N/A
MPQS	1	122	944.92	N/A	MPQN	2	122	944.92	N/A
MPQS	2	122	944.92	N/A	MPQN	3	122	944.92	N/A
MPQS	3	122	944.92	N/A	MPQN	1	150	1206.40	N/A
MPQS	1	150	1206.40	N/A	MPQN	2	150	1206.40	N/A
MPQS	2	150	1206.40	N/A	MPQN	3	150	1206.40	N/A
MPQS	3	150	1206.40	N/A	MPQN	1	165	1518.58	N/A
MPQS	1	165	1518.58	N/A	MPQN	2	165	1518.58	N/A
MPQS	2	165	1518.58	N/A	MPQN	3	165	1518.58	N/A
MPQS	3	165	1518.58	N/A	MPQN	1	182	1821.92	N/A
MPQS	1	182	1821.92	N/A	MPQN	2	182	1821.92	N/A
MPQS	2	182	1821.92	N/A	MPQN	3	182	1821.92	N/A
MPQS	3	182	1821.92	N/A	MPQN	1	200	2185.80	N/A
MPQS	1	200	2185.80	N/A	MPQN	2	200	2185.80	N/A
MPQS	2	200	2185.80	N/A	MPQN	3	200	2185.80	N/A
MPQS	3	200	2185.80	N/A	MPQN	1	222	2713.93	N/A
MPQS	1	222	2713.93	N/A	MPQN	2	222	2713.93	N/A
MPQS	2	222	2713.93	N/A	MPQN	3	222	2713.93	N/A
MPQS	3	222	2713.93	N/A	MPQN	1	245	3285.02	N/A
MPQS	1	245	3285.02	N/A	MPQN	2	245	3285.02	N/A
MPQS	2	245	3285.02	N/A	MPQN	3	245	3285.02	N/A
MPQS	3	245	3285.02	N/A	MPQN	1	270	3997.61	N/A
MPQS	1	270	3997.61	N/A	MPQN	2	270	3997.61	N/A
MPQS	2	270	3997.61	N/A	MPQN	3	270	3997.61	N/A
MPQS	3	270	3997.61	N/A	MPQN	1	300	4945.21	N/A
MPQS	1	300	4945.21	N/A	MPQN	2	300	4945.21	N/A
MPQS	2	300	4945.21	N/A	MPQN	3	300	4945.21	N/A
MPQS	3	300	4945.21	N/A	MPQN	1	330	5968.62	N/A

TABLE 2 - AIR MEASURING DEVICE CONNECTIONS (CONT'D)

FAN TYPE	FAN CLASS	FAN SIZE	k	n	FAN TYPE	FAN CLASS	FAN SIZE	k	n
MPQS	1	330	5968.62	N/A	MPQN	2	330	5968.62	N/A
MPQS	2	330	5968.62	N/A	MPQN	3	330	5968.62	N/A
MPQS	3	330	5968.62	N/A	MPQN	1	365	7290.21	N/A
MPQS	1	365	7290.21	N/A	MPQN	2	365	7290.21	N/A
MPQS	2	365	7290.21	N/A	MPQN	3	365	7290.21	N/A
MPQS	3	365	7290.21	N/A	MPQN	1	402	8869.55	N/A
MPQS	1	402	8869.55	N/A	MPQN	2	402	8869.55	N/A
MPQS	2	402	8869.55	N/A	MPQN	3	402	8869.55	N/A
MPQS	3	402	8869.55	N/A	MPQN	1	445	10827.92	N/A
MPQS	1	445	10827.92	N/A	MPQN	2	445	10827.92	N/A
MPQS	2	445	10827.92	N/A	MPQN	3	445	10827.92	N/A
MPQS	3	445	10827.92	N/A	MPQN	1	490	13135.01	N/A
MPQS	1	490	13135.01	N/A	MPQN	2	490	13135.01	N/A
MPQS	2	490	13135.01	N/A	MPQN	3	490	13135.01	N/A
MPQS	3	490	13135.01	N/A	SF	2	165	1361.00	N/A
SF	2	105	592.00	N/A	SF	2	182	1673.00	N/A
SF	2	122	842.00	N/A	SF	2	200	1942.00	N/A
SF	2	135	963.00	N/A	SF	2	222	2454.00	N/A
SF	2	150	1147.00	N/A	SF	2	245	3010.00	N/A

Air Measuring at the Fan Inlets

- COMETER is a probe attached to the fan bearing support on Comefri Forward Curve fans from size 7 x 7 up to 18 x 18. The probe is located on the outboard side of the housed fan assembly. The probe is piped to the negative (-) port of a factory mounted transducer on the fan wall. The positive (+) port is left open to the fan section. Wiring is not provided to the transducer unless factory packaged controls were selected.
- PIEZORING (PIEZOMETER) is a fitting or series of fittings in the inlet cone(s) of housed fans larger than 18 x 18 and all sizes of Plenum fans that are combined into a single connection piped to the negative (-) port of a factory mounted transducer on the fan wall. The positive (+) port is left open to the fan section. Wiring is not provided to the transducer unless factory packaged controls were selected.

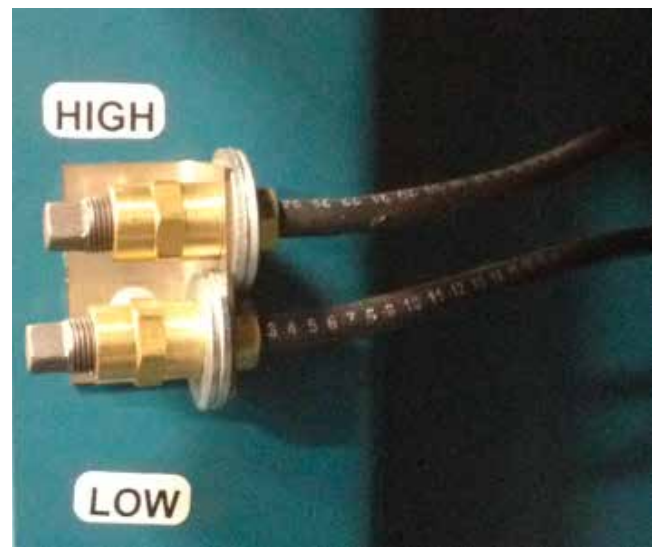

LD17231

FIGURE 11 - HIGH AND LOW CONNECTIONS FOR AN IN FAN AIR MONITORING SYSTEM

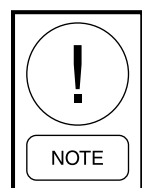

The fan manufacturer does not recommend placement of the flow measuring probes inside the fan inlet cone in the path of airflow. These devices create disturbances and unpredictable performance losses.



FIGURE 12 - HIGH AND LOW CONNECTIONS AND ASSOCIATED TUBING FOR FAN MOUNTED AIR MONITORING SYSTEM

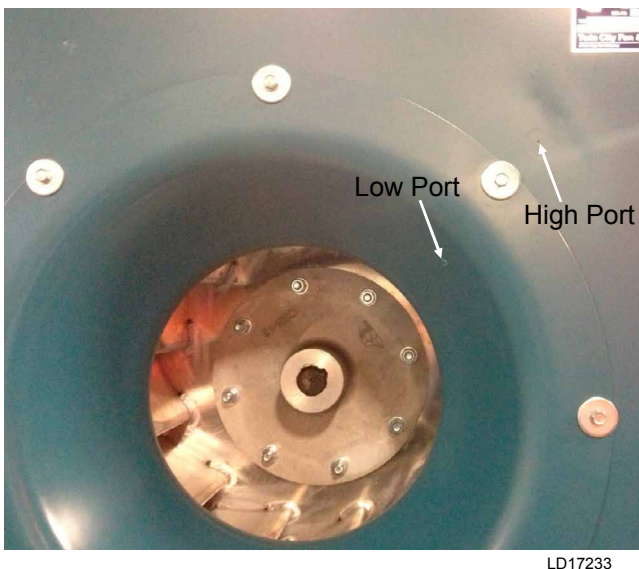

FIGURE 13 - PORT LOCATIONS FOR FAN MOUNTED AIR MONITORING SYSTEM

Air Measuring at Unit Outside Air Inlets

- AMS-60 used on indoor air handlers usually measure outside air. This can be provided with one or two pairs of positive (+ or High) and negative (- or Low) pressure tube connections. Connect (+) & (-) respectively to the (+) & (-) ports of the transducer(s). Wiring & transducer are not provided unless factory packaged controls were selected.

- EAML used on outdoor air handlers usually to measure outside air. This can be provided with one or two pairs of positive (+ or High) and negative (- or Low) pressure tube connections. Connect (+) & (-) respectively to the (+) & (-) ports of the transducer(s). Wiring & transducer are not provided unless factory packaged controls were selected.

AMS-60 Damper

General

The YORK AMS-60 is an airflow monitoring device which combines the functions of control damper and airflow measurement station into one assembly. It is ideally suited for factory installation in air handling units. The YORK AMS-60 is tested to AMCA Standard 611-95 and qualifies to bear the AMCA Ratings Seal for Airflow Measurement Performance.

Damper Operation

The AMS-60 airflow monitoring damper design incorporates a low leakage control damper with stationary, vertical air monitoring blades and air straightening section into one assembly. The control damper utilized for modulating airflow is the ultra-low leak Ruskin CD-60 with its standard blade and jamb seals used for low leakage. Strategically placed stationary and vertical airflow sensing blades measure the airstream velocity pressure. Air tubing/piping connections are provided to connect the sensing blades to an optional factory-mounted transducer. The transducer converts the velocity pressure from the sensing blades to an electrical output signal for the Building Automation System (BAS). The output signal corresponds directly to flow through the damper. The BAS compares this signal to the design CFM setpoint as determined by the particular mode of operation of the HVAC system. In normal operation, this setpoint corresponds to the minimum outside air ventilation required by the system design to meet ASHRAE Standard 62. Based on the difference between the actual CFM reading and the desired setpoint, the BAS would send a signal to the optional, factory-mounted control damper Actuator to position the damper blades as necessary to ensure that the actual outside airflow meets the desired level.

No Calibration Required

The AMS-60 airflow monitoring damper is factory calibrated. Calibration is not required at the jobsite.

Ductwork Inlet Requirements

When connecting the ductwork to a mixing box with an AMS-60 damper, a minimum of one (1) equivalent duct diameter of straight duct is required before entering the AMS-60 damper.

1 equivalent duct diameter = d

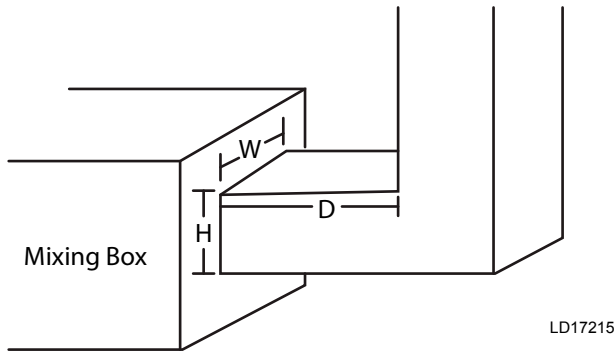

LD17215

FIGURE 14 - DUCTWORK INLET REQUIREMENTS

If one equivalent duct diameter cannot be achieved during installation, the rectangular elbow may be substituted with a radius elbow. The outside radius must have a R/W ratio of 0.75 or more.

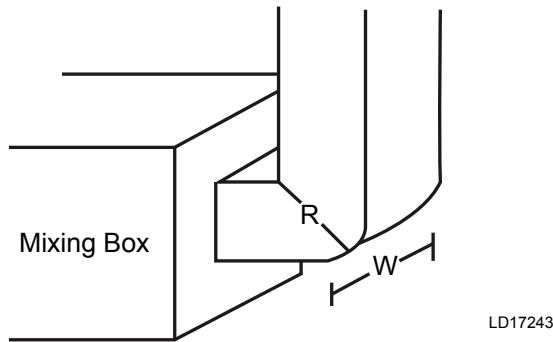

LD17243

FIGURE 15 - DUCTWORK RADIUS

Damper Linkage Arrangements

The AMS-60 mixing box will ship with independent return air and outside air damper actuators if selected in the MB or FM segments.

Louver/Damper Combination

Outdoor AHU economizer and mixing box sections will utilize an integral rain resistant, airflow sensing louver/damper combination with operation and set-up similar to the AMS-60. The indoor and outdoor AHU designs have the same possible damper configurations.

Damper Configurations

There are 3 possible damper configurations, 25% Sensing option (Min./Max.), 25%/75% Sensing option, and 100% Sensing option.

- 25% Sensing Option (Min./Max.)

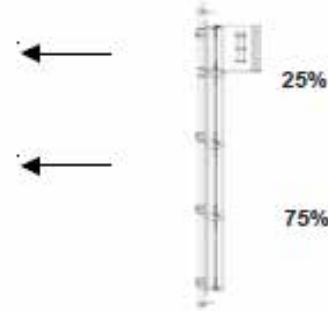

LD17244

FIGURE 16 - 25% SENSING OPTION

The 25% Sensing (Min./Max.) option arrangement is a dual damper design and used for measuring the minimum outside air requirement. In this arrangement, the 25% damper would be for monitoring airflow through the first 25% down to 3.75% nominal flow and the 75% damper would have a separate actuator and used for economizer control only.

This option would be the best low cost option for areas in which economizer cycles are not often seen, such as the southeast, and are required to constantly operate in at the minimum outside air position.

- 25/75% Sensing Option

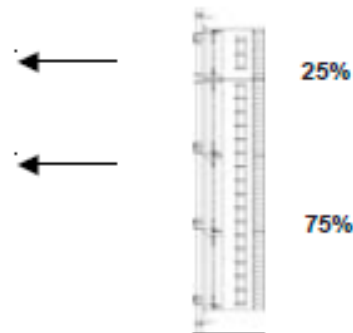

LD17245

FIGURE 17 - 25%/75% SENSING OPTION

The 25/75% Sensing option arrangement is similar to the 25% Sensing (Min./Max.) option, but allows you to measure airflow throughout the economizer cycle also. In this arrangement, the 25% damper would be for monitoring nominal airflow through the first 25% down to 3.75% and the 75% damper would be for monitoring the remaining 75%.

- 100% Sensing Option

The 100% sensing arrangement is a single damper design used to measure airflow throughout the full range of the outside air damper down to 15% of nominal airflow.

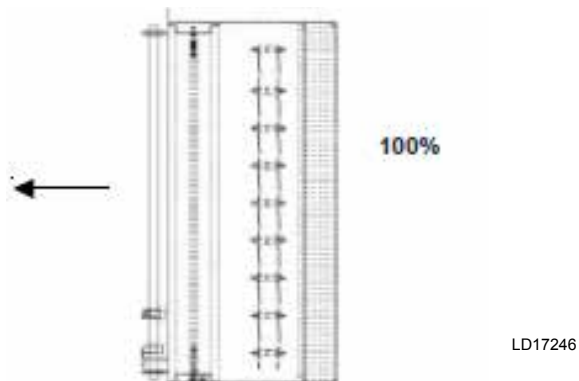

FIGURE 18 - 25%/75% SENSING OPTION

The 100% sensing option is the lowest cost option, but should not be utilized when minimum airflow to be sensed falls below 15% nominal flow. The 25% Sensing (Min./Max.) and 100% Sensing option arrangements will be the most prevalent.

The 100% Sensing arrangement with the outside and return air dampers tied to a common actuator, will usually be the most common configuration and cost-effective solution. However, areas in which economizer cycles are not often seen and operate primarily in minimum outside air position, the 25% Sensing option should be the preferred option for lowest airflow monitoring and a cost-effective solution.

In each of the available configurations, the minimum airflow across the sensing portion of the airflow monitoring station is 300 FPM for the indoor AHU and 345 FPM for the outdoor AHU.

Factory Mounted Control Option

The AMS-60 airflow monitoring station may be ordered with or without Factory-mounted End Devices. The Optional End Devices must be selected through the YorkWorks program and consist of the following:

- Modulating, Spring Return Actuator(s)
- Low Pressure Transducer(s)

YorkWorks will provide all wiring schematics.

Jumper Selections

When selected, the AMS-60 factory provided transducers technically provides six (6) jumper selections which allow you to select the appropriate range for your application. However, only three (3) are applicable to the AMS-60 function. The jumper selections are as follows: 0-1", 0-.5", and 0-.25". These are field adjustable. To determine the correct jumper setting for your application, refer to the equation and examples on *Table 3 on page 27* for indoor AHUs and *Table 4 on page 28* for outdoor AHUs.

Input Power

A 24VAC power supply can be wired into the supply voltage terminals on the Factory-mounted Actuator and Transducer.

CFM Input Signal to Damper Actuator

2-10VDC (BELIMO)

0-10 VDC (JOHNSON CONTROLS)

CFM Output Signal from Transducer

0-10VDC

Sequence Of Operation

A 0-10 VDC or 2-10VDC control signal is sent to the AMS 60 damper actuator from the Building Automation System (BAS). The BAS maintains the required cfm by modulating the actuator on the control damper. The BAS receives a 0-10 VDC signal back from the transducer, confirming the cfm supplied. Upon loss of power, the AMS-60 actuator returns to a closed position.

End Devices Requirements*

It is necessary for an independent contractor to provide controls capable of sending 0-10 VDC or a 2-10VDC signal to the actuator and receiving a 0-10VDC signal back from the transducer. A 24VAC power source must be provided.

* This paragraph only applies if the actuator and transducer are YORK supplied. Any controls provided by "others" are the contractor's responsibility.

AHU Airflow Station Specifications

Furnish and install, at locations indicated on plans and/or schedules, an air monitoring station integral with outside air control damper, stationary airflow sensing-device, and air straightening section. The integral air monitoring station shall incorporate pressure sensing ports built into the sensing device and shall control the minimum amount of outside air as recommended by ASHRAE 62-2001. The airflow monitoring station must be tested in accordance with AMCA Standard 611-95 in an AMCA registered laboratory. The air-

flow monitoring station must bear the AMCA Certified Ratings Seal for Airflow Measurement Performance. If airflow station is internally mounted inside air handling unit and incorporates a control damper, the control damper must comply with leakage rates of damper specification.

If ASHRAE 90.1 is referenced, also include

If airflow station is internally mounted inside air handling unit and incorporates a control damper, the control damper must comply with leakage rates per ASHRAE 90.1-1999. All damper leakage rates must be provided in submittal data on a CFM/FT² at 1" w.g. basis.

AMS-60 (Indoor AHU)

Use the following equation to determine the correct jumper setting for your application:

$CFM = (FREE\ AREA * K_a) * P_{ams} (1/m)$, where $K_a = 3213$

$P_{ams} = Range\ of\ transmitter, and (1/m) = 0.54.$

TABLE 3 - INDOOR UNIT EXAMPLE

UNIT NAME	FAN DESIGN FLOW (CFM)	AMS SENSING (%)	AMS O.A. SETPOINT (CFM)	AMS-60 SENSING DAMPER DIMENSIONS 100% SENSING		AMS SENSING AREA (SQ. FT.)
				"A" DIM. (IN.)	"B" DIM. (IN.)	
AHU-01	21370	25	7000	22.5	32.75	5.1

RANGE: 0.0 TO +0.25	
MIN	MAX
0	0.25

Recommended operating range is 345-2,000 FPM. Operation outside these parameters is not recommended.

VOLTS	PAMS	CFM	FPM
0	0.00	0.0	0.00
1	0.03	2243.0	438.33
2	0.05	3261.3	637.32
3	0.08	4059.5	793.31
4	0.10	4741.8	926.64
5	0.13	5349.0	1045.30
6	0.15	5902.4	1153.45
7	0.18	6414.8	1253.58
8	0.20	6894.4	1347.31
9	0.23	7347.2	1435.78
10	0.25	7777.3	1519.84

Airflow Monitoring Station with Louvers/ Hoods (Outdoor AHU)

Use the following equation to determine the correct jumper setting for your application:

$$\text{CFM} = (\text{FREE AREA} * \text{Ka}) * \text{Pams} (1/\text{m}), \text{ where } \text{Ka} = 3833$$

$$\text{Pams} = \text{Range of transmitter, and } (1/\text{m}) = 0.52.$$

TABLE 4 - OUTDOOR UNIT EXAMPLE

UNIT NAME	FAN DESIGN FLOW (CFM)	AMS SENSING (%)	AMS O.A. SETPOINT (CFM)	AMS-60 SENSING DAMPER DIMENSIONS 100% SENSING		AMS SENSING AREA (SQ. FT.)
				"A" DIM. (IN.)	"B" DIM. (IN.)	
AHU-01	21370	25	7000	22.5	32.75	5.1

RANGE: 0.0 TO +0.25	
MIN	MAX
0	0.25

Recommended operating range is 300-2,000 FPM. Operation outside these parameters is not recommended.

VOLTS	PAMS	CFM	FPM
0	0.00	0.0	0.00
1	0.03	2880.7	564.84
2	0.05	4130.8	809.96
3	0.08	5100.4	1000.07
4	0.10	5923.4	1161.45
5	0.13	6652.2	1304.35
6	0.15	7313.7	1434.06
7	0.18	7924.1	1553.75
8	0.20	8493.9	1665.47
9	0.23	9030.4	1770.66
10	0.25	9538.9	1870.38

Locating and Installing Actuators

Johnson Controls standard actuators are direct coupled on the damper jackshaft. Refer to the instructions in the *Solution XT Air Handling Units - Installation and Assembly Manual (Form 102.20-N1)* and *York Custom Air Handling Units - Installation and Assembly Manual (Form 102.20-N3)* to install the Johnson Controls actuators.

Damper Blade Orientation

Use the following instructions to orient the damper blades.

Return Air and Mixing Dampers

1. Position the blades so that they will be open after the actuator is installed, which will be the dampers spring return position.
2. Note whether the damper shaft is rotated clockwise or counterclockwise.

Outside Air and Exhaust Air Dampers

1. Position the damper blades so that they will be closed with the power *off*, which will be the dampers spring return position. Note if the damper shaft is rotated clockwise or counterclockwise.

2. With the actuator shaft clamp tightened to the damper jackshaft, and the damper shaft completely rotated to its proper position, manually operate the actuator to its fully actuated position, using the crank arm provided with the actuator.
3. Release the spring to allow the damper to go back to its original position, which will verify the actuators spring rotation and stroke.
4. Set the damper actuators rotation selector switch to the proper rotation required to actuate the damper. The damper actuator will always be opposite the spring return rotation.

Energize Fan Motors

Use the following instructions to energize the fan motors:

1. Observe the fan(s) for smooth operation.
2. Check the motor nameplate for the full load amp (FLA) rating.
3. Check the current draw of each leg of each motor.

Variable Frequency Drive (VFD)

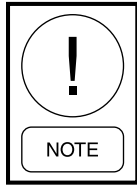

Johnson Controls air modulators are, unless otherwise selected, provided with start-up service. See forms 100.41-NO1 and 100.42-NO1.

The VFD controlling the speed of the AHU fan(s) needs to be set up properly so the fan does not run at resonant frequencies. This is true whether the VFD is field or factory mounted. An option is available when ordering the AHU to select Inverter Drive Balance (Sweep Balance). When the option is selected, the factory provides a document or label attached to the fan assembly that lists any values that exceed the peak to peak tolerance. See *Figure 19* below. These values are referred to as Skip Frequencies (Jump or Lockout Frequencies). The technician performing start up of the VFD is to enter these values in the VFD programming according to the manufacturer's instructions. This step will prevent continuous operation at the resonant frequencies listed on the label. If the option was not selected on the AHU order, it is the customer's responsibility to have the Inverter Drive Balance (Sweep Balance) performed and enter any detected Skip Frequencies (Jump or Lockout Frequencies) in the VFD program. This should be done during start up.

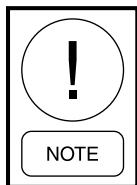

Failure to properly set up the VFD before applying power to the motor will void the fan and motor warranty.

SWEEP BALANCE RESULTS:	
The values listed below exceed the peak to peak tolerance through the sweep balance. When programming the Variable Speed Drive, lock-out or skip these frequency ranges during fan start up and shut down. If the peak is marked as N/A, it was within tolerance and does not need to be locked out or skipped.	
Lock-out (Skip) Freq. Range(s)	
PEAK #1	975 - 1025 (RPM) 27.9 - 29.3 (Hertz)
PEAK #2	1348 - 1407 (RPM) 38.5 - 40.2 (Hertz)
PEAK #3	(RPM) (Hertz)

LD16564

FIGURE 19 - EXAMPLE OF SWEEP BALANCE RESULTS LABEL ON FAN HOUSING

Check Doors And Latches

Refer to the service manual for adjusting and replacing the doors.

Solution XT doors are shipped with metal shipping spacers glued onto the edges of each door. They are located on three edges of each door (top, latch side & bottom) (*Figure 20* on page 29). The spacers should be left in place until the AHU is placed in its final location and multiple skid AHUs are fully assembled. After AHU installation use a channel lock pliers or a screwdriver to remove the spacers. Do not damage the metal door panel. Slight impressions left on the door gasket by the spacers will rebound in approximately a week.



LD16574

FIGURE 20 - METAL SPACERS ON SOLUTION XT DOORS

Energy Recovery Wheel

Configuring the AHU

Indoor AHUs - All indoor AHUs will accommodate vertical energy recovery wheel segments in a tiered configuration as shown in *Figure 21* on page 29.

Outdoor AHUs - All outdoor AHUs will accommodate horizontal energy recovery wheel segments in a low-profile, single AHU arrangement as shown in *Figure 22* on page 30.



Keep hands away from rotating wheel! Contact with the rotating wheel can cause physical injury.

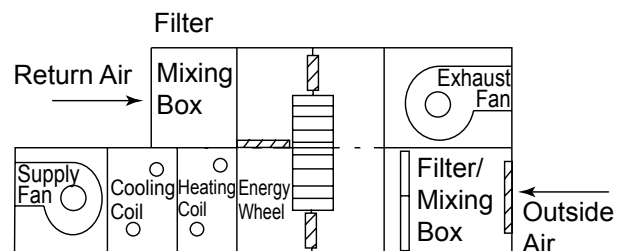

LD16566

FIGURE 21 - VERTICAL WHEEL FOR INDOOR AHU

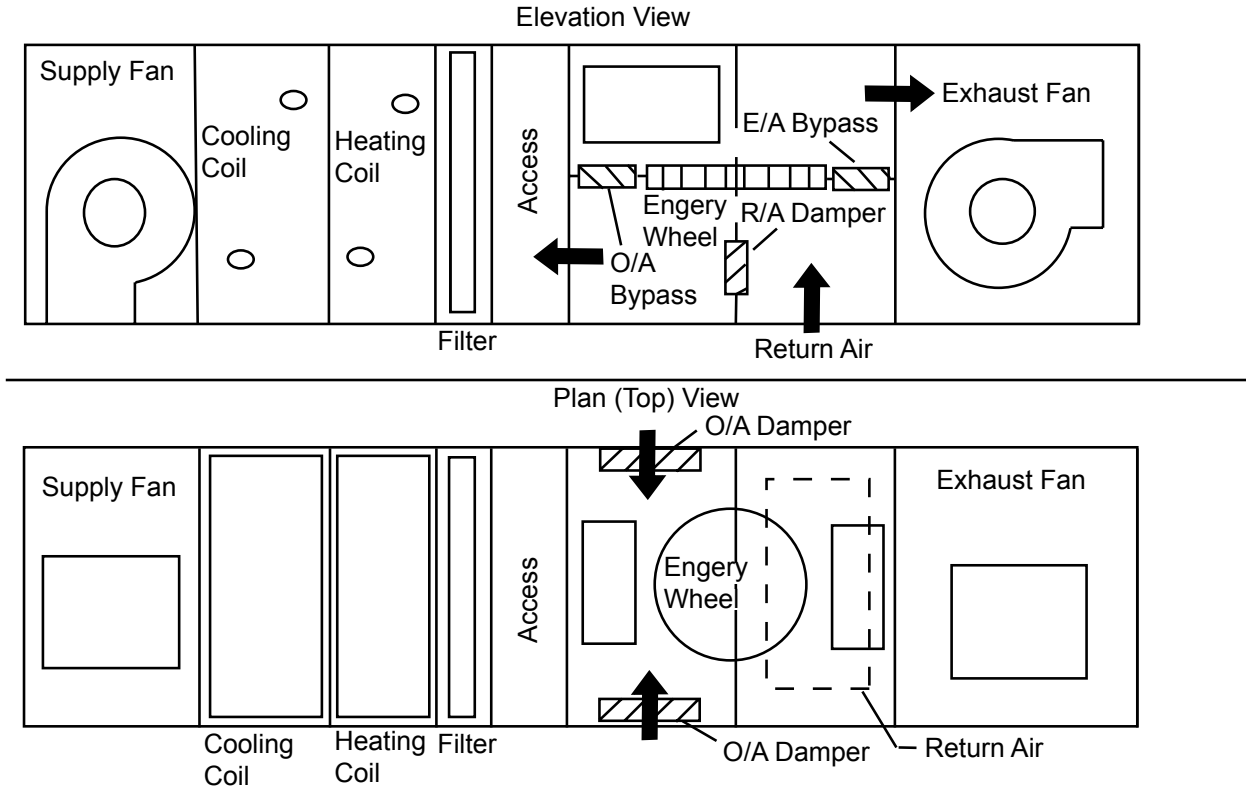

LD09641a

FIGURE 22 - HORIZONTAL WHEEL FOR OUTDOOR AHU



When the AHU is operating normally or temporarily, the energy recovery wheel must rotate to prevent clogging.



Many energy recovery wheels are susceptible to damage if the AHU reaches a maximum temperature, which can occur if the heating valve remains open when the AHU is off. The maximum temperatures across energy recovery wheels:

1. Thermotech - 140°F
2. Innergy Tech - 122°F
3. NovelAire® Technologies - 200°F
4. Airxchange® - 170°F

Airxchange®

Start-Up Procedure

1. With the power off, turn the wheel clockwise (as viewed from the pulley side) to verify that the wheel turns freely through a 360° rotation as shown in *Figure 23 on page 31*.
2. Before applying power to the drive motor, confirm that the wheel segments are fully engaged in the wheel frame, and the segment retainers are completely fastened as shown in *Figure 23 on page 31* and *Figure 24 on page 32*.
3. With hands and objects away from the moving parts, activate the AHU, and confirm the wheel rotation. The wheel rotates clockwise from the pulley side.
4. If the wheel has difficulty starting, turn the power off, and inspect it for excessive interference between the wheel surface and each one of the four diameter seals. To correct, loosen the diameter seal adjusting screws and back adjustable diameter seals away from surface of the wheel. Apply power to confirm the wheel is free to rotate, then readjust and tighten hub and diameter seals as shown in *Figure 25 on page 32*.

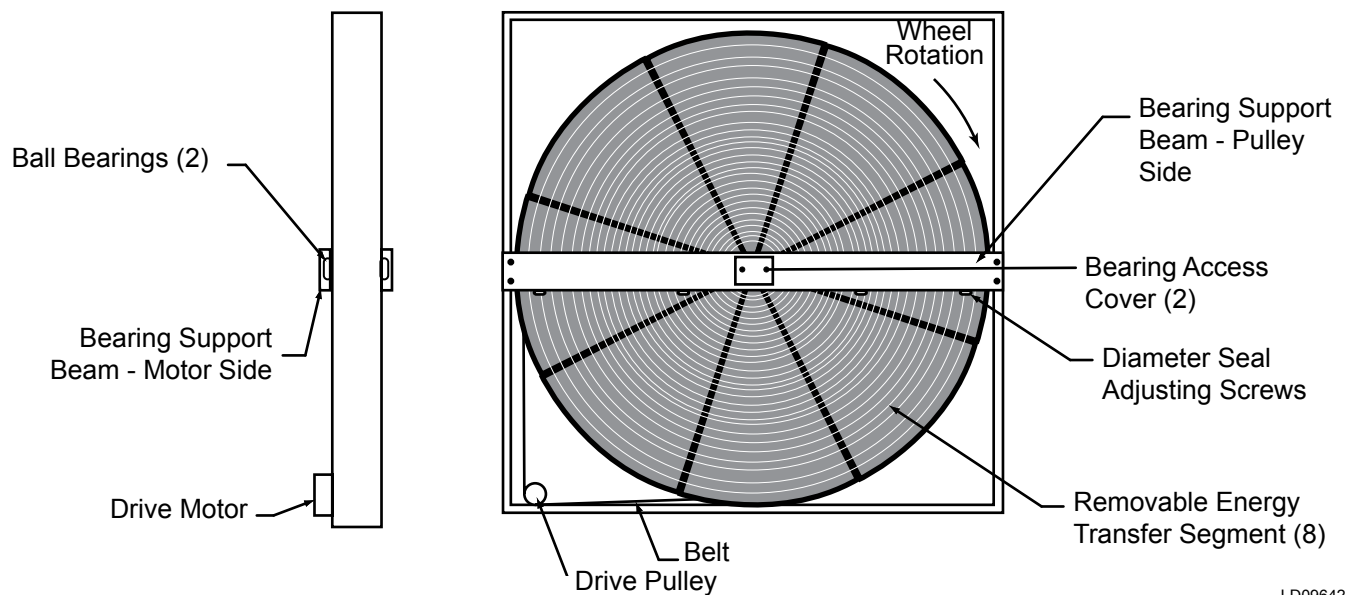

LD09642

FIGURE 23 - ENERGY RECOVERY WHEEL - PULLEY SIDE

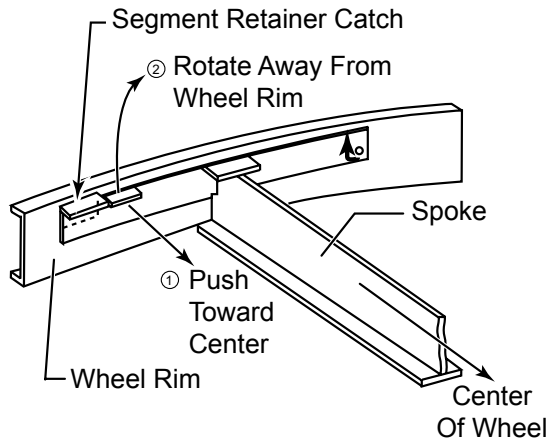

LD09643

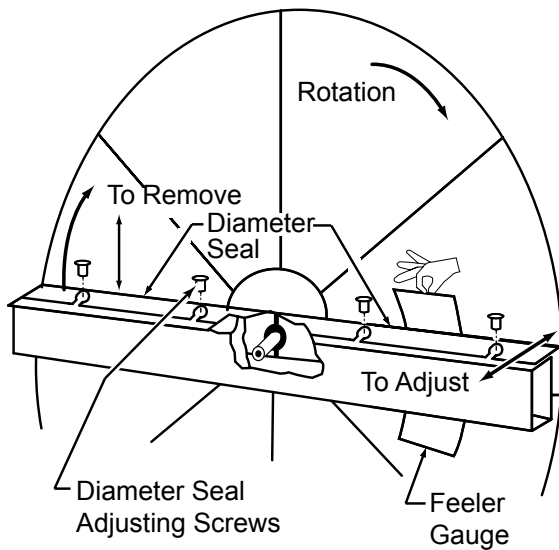
FIGURE 24 - SEGMENT RETAINER

LD09644

FIGURE 25 - DIAMETER SEAL ADJUSTMENT**Innergy tech®****Start-Up Procedure**

1. Make sure all bearing bolts and set screws are tight. A special seal lacquer is factory applied. This is a visual aid that will warn you if the pillow block bolts or the bearings set screws have loosened over time or during transport. A seal without cracks is the indication that bolts and screws have not loosened.
2. Be sure to use all lifting eye bolts when positioning energy recovery wheel into unit or ducting location, and that weight is evenly distributed. If the eye bolts need to be removed, bolts or plugs should replace them in order to avoid any air leakage from these holes (required with top, bottom and side galvanized plate option only).
3. Grease both pillow block bearings on the wheel, using a NLGI grade 2 consistency, mineral oil lithium or lithium complex base grease.
4. Before start-up, make sure the wheel turns by hand and does not bind. All contact between the seals and media should be verified and the seals adjusted if needed.
5. Visually inspect the wheel to ensure it is centered and does not tilt. If there is any indication of a problem, call Innergy tech at 1-800-203-9015.
6. Does the power supply match the supply required by the electrical equipment? If not, the electrical equipment or the power supply must be changed. The wheel identification tag located near the electrical input gives the proper voltage to use.

Check the drive motor by bump starting it. Check the wheel rotation to ensure it is turning in the correct direction. If the wheel is turning backward, reverse the motor rotation.

Thermotech®

Start-Up Procedure

1. Remove the belts from the motor sheave and rotate the wheel a minimum of one full Revolution. The seals are non-contact. If the wheel does not rotate freely it may be due to the wheel being in contact with the seal. If the wheel cannot be turned by hand contact Thermotech.

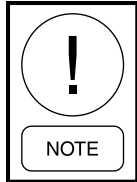

For TC sizes 14-82. To remove the belt, an idler pulley will need to be loosened.

2. The side seals should also be checked for clearance to insure nothing has moved in shipping. If the wheel is in contact with the aluminum encasing the side seals, the wheel will need to be re-centered in the casing. This is done by loosening the bearing bolts and by using the bearing adjusting bolts. Re-center the wheel insuring proper side seal clearance. Re-tighten bearing bolts as follows: 3/8 inch = 35 ft lbs., 1/2 inch = 45 ft. lbs., 3/4 inch = 100 ft lbs.
3. Check to insure sheave/bushing is not rubbing on the gear box.
4. At this point the wheel should rotate freely with no drag or rubbing, with the exception of the rivets at the hub cover. A slight rub here is acceptable. Proper wheel rotation technique:

Rotate wheel by applying pressure to the rim not the media. Care should be taken not to damage the media face.

5. The seals are set at the factory and should not require adjustment. If the seals are rubbing on the media face, due to installation or other factors, the seals will need to be adjusted. First, rotate the wheel one full revolution and determine where the wheel media face is rubbing on the seal. Working on one seal quadrant at a time, loosen the seal tek screws. Then, move the seal away from the wheel surface until no more rubbing is noticed. A typical large diameter wheel will have a flatness variation of 1/16" from the high to the low point of the wheel surface. If the seals are adjusted correctly, the seal gap will vary that much as the wheel turns, but it should never be touching the wheel surface.

6. If the unit is supplied with an adjustable purge, determine the proper purge angle from the ordering code on the unit nameplate or the specific data for your project. Insure proper purge angle setting is correct by visual inspection. The minimum purge angle is 1 degree. There are 10 adjustment points in one degree increments.

Purge Adjustment: TF Series Wheels

The purge angle can be adjusted with each purge setting hole equal to one degree. The bolts that position the purge angle are located on the backside of the purge and are not visible. First loosen bolt 2 and 3. Then remove the bolt 1. The whole purge section is then movable to a new location. Re-install bolt 1 in the new hole location and re-tighten all the bolts.

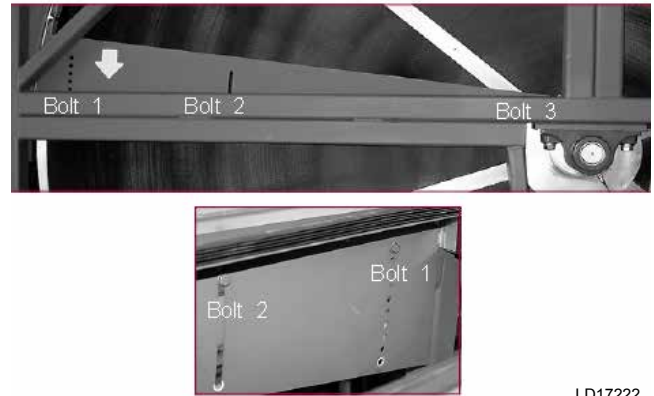

LD17222

FIGURE 26 - PURGE ANGLE DETAIL

Purge Adjustment: TC Series Wheels

The purge angle can be adjusted with each purge setting hole equal to one degree. Bolt number 1 positions the purge angle and is located on the front side of the purge. Bolt number 2 is the pivot point and is located on the inside of the frame and is not visible. First loosen bolt 2. Then remove bolt 1. The purge wiper section is then movable to a new location. Re-install bolt 1 in the new hole location and re-tighten all the bolts.

Purge angle detail showing bolt locations on front side of purge. The purge wiper bolt 2 pivot point is slotted so as the purge wiper is adjusted it can be moved so that the outer edge of the seal is always in contact with the main rotor seal.

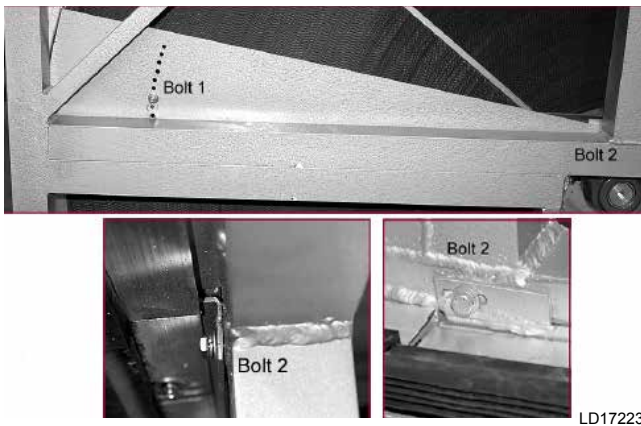

FIGURE 27 - PURGE ANGLE DETAIL

7. Grease bearings using Dow Corning Molykote BR2-plus Lithium based high pressure grease. Apply the grease to the fitting while turning wheel until a slight amount of grease is purged. Remove visible grease residue from the bearing. The bearings are filled with grease prior to shipment. This step may be required if the units have been idle on the job site for more than 6 months. Put belts back on pulley.
8. If the unit is provided with a VFD, verify the motor is wired for the correct voltage provided by the VFD.

NovelAire® Technologies

Start-Up Procedure

1. Does the rotor rotate freely by hand? If not, re-check the seal to determine whether or not it is binding and if so adjust seals following the instructions below.
2. Is the motor rotation correct? This can be checked by detaching the belts from the drive sheave and bumping the motor. The sheave should be rotating in the direction such that the belt will result in rotation per the exterior markings. If not, rewire the motor.
3. Does the air flow orientation match up to design? See the identification markings on the cassette.
4. Are the belts on correctly and sufficiently tight? Belt length is set by the manufacturer. Consult NovelAire® Technologies if the belt appears too loose.
5. Is the VFD programmed to control the unit and to prevent frost formation? If not, follow the instructions in the manual accompanying the VFD and/or consult NovelAire® Technologies.

Indirect Fired Gas Heat Start Up

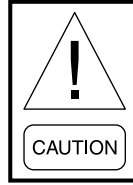

For your safety, this product requires a check, test, and start-up adjustment by a qualified HVAC technician. Do not use for temporary heat prior to start-up.

This gas burner has been carefully inspected and tested at the factory; however, different conditions at the job site, including controls that have been added at the time of installation, require careful testing and final adjustment for satisfactory operation. The Burner Test Report/Factory Specification Sheet in each AHU shows the general data recorded during the operation and safety tests at the factory. This data should be used as a general guide; with final data recorded on the start-up form. Do not exceed 550°F flue temperature at the ID fan inlet. Do not exceed 200°F supply air temperature.

Review the burner control literature, including wiring, piping, cut sheets and drawings before attempting to start this gas heating equipment.

All factory test start up burner specifications are located on a laminated Burner Test Report/Factory Specification Sheet located on the inside of the control panel door. Each gas burner has been test run and inspected at the factory. Adjustments to the component settings are typically not required. However, measurements of the system parameters should be taken and compared to the measurements recorded on the burner test report, to ensure safe and reliable operation.

Use the following instructions to start an indirect fired gas heat system on an AHU.

Identify the Gas Burner Type

Two types of indirect fired gas burners are used on the AHUs: Powerflame and the Eclipse series.

The Powerflame series offers a turndown (modulating ratio) of 3:1 or 10:1. The Powerflame is easily identifiable by the motorized gas valve with external linkage connecting the air dampers on the burner air inlet.

The Eclipse series uses an air/gas ratio regulator with no external linkage, and has a turndown range of 10:1 to 25:1 (sometimes greater). A visible external plastic tube is used to transmit gas pressure from the burner to the regulator. No external linkage is used.

Both burners utilize a combustion air blower, and use an exhaust blower, called an induced draft (ID) blower, which keeps the combustion chamber at a slight negative pressure. Verification of this negative pressure and other system parameters is part of a proper start up procedure.

Preliminary Coordination

Contact the contractor/customer who requested start-up, and do the following:

- Ensure the AHU and system is capable of design airflow for gas heat start-up.
- Ensure reliable power is available.
- Verify the following:
 - Verify the AHU was properly started up.
 - Gas lines are purged of air to the equipment valve.
 - Controls are complete.
 - Flue (stack) is correctly installed, if parts were shipped loose.

Recommended Tools

- Electrical Multimeter with Amprobe.
- Heating AHU Installation and Operation Instructions, which are provided with every heating AHU for technical information and troubleshooting.
- Magnehelic Gauge 0-25 in WC, Dwyer Series 2000 or Model 1227 Dual Range Manometer for checking pressure over fire (draft).
- Control Signal Generator, 0 to 20 mA (Altek-234 or 334A) - For 2 to 10 VDC signal add 500 ohms in series with signal generator.

- Magnehelic Gauge 0-15 in WC and 0 to 3 lb (Dwyer series-2000) or Monometer (Dwyer- 1227) Dual Range Monometer for checking supply gas pressure and manifold gas or pilot gas pressure.
- Honeywell - S7800A Test Module for use on (Honeywell-7800) Series Relay Module, which is available through Airside Parts
- Flue Gas Analyzer (CO₂ and O₂)
- Stack Thermometer (0°F-1000°F approx.)
- Digital Manometer (replaces Magnehelic Gauge): Digital Manometer, Cat. #475-1 FM-AV Series: 475-1 Mark III, Range: 0 to 19.99 In. W.C. from Dwyer Instruments, Inc.

Pre-Start-Up Checklist

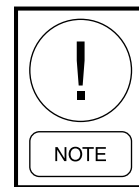

Condensate trap must be installed prior to start-up by the installing contractor.

Refer to *Figure 28 on page 36* for installing the gas furnace condensate drain trap.

Use the following information to check the AHU before starting it:

- Verify the AHU was properly started up, and that airflow is at the design maximum for the heating cycle. Refer to the air balance report.
- Set the bypass damper, if provided.
- Airflow proving switch for main supply fan installed and operational.
- Check with the control technician: two-minute post-purge programmed in AHU controller. Upon call for unit stop, burner cycles off, then AHU fan cycles off two minutes later.

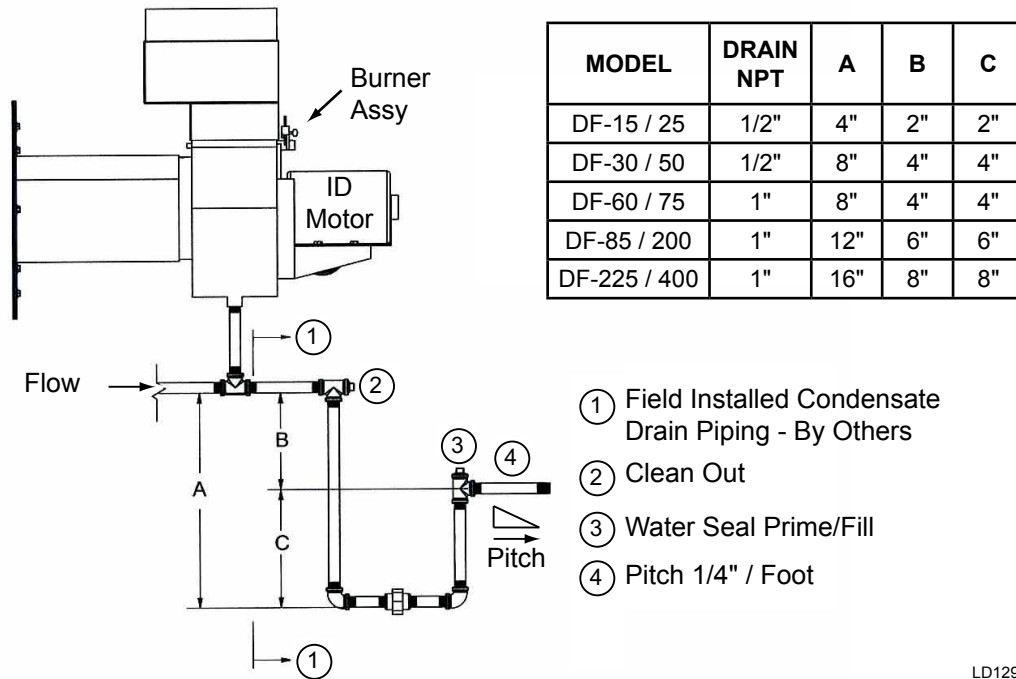

LD12912

FIGURE 28 - GAS FURNACE CONDENSATE DRAIN TRAP**Checking the Burner**

1. Open the fuse disconnects before working on burner as shown in *Figure 29 on page 37*.
2. Check all wire terminations for tightness.
3. Check that the incoming voltage(s) are correct. Compare the measured voltages to the burner motor and ID motor nameplates, and the burner test report. Reset the fuse disconnects.
4. Check for the correct rotation of the three phase burner and ID motors.
5. Verify that the contractor purged the new gas lines of air up to the manual valve on the gas train.
6. Open the valves, which were closed for shipping. Check that all manual valves operate without leaks.
7. The flue (stack) damper is located at the discharge of the ID blower and was closed for shipping. Release the locking mechanism, and set the damper to match the position indicated by the scribed markings. Lock it in place as shown in *Figure 30 on page 37*.
8. Inspect the condensate drain trap to see that it is large enough.
9. Measure the gas supply pressure coming into the gas train as shown in *Figure 31 on page 37*. Gas pressure can be greater than shown on the burner test report, but it must be between the min./max. values listed in *Table 7 on page 41*.
10. Visually check that the high temperature safety limit is set for a 200-230°F range. The limit switch is typically mounted behind the burner control panel.
11. Connect a 0-15 inch gas pressure gauge or other suitable instrument to the gas manifold port. The gas pressure will be measured when running. Refer to Step 4 in *Starting the Burner*.
12. On Powerflame burners, the test port is downstream of the main regulator, typically on a standard tee fitting in the main gas line.
13. On Eclipse burners, the test port is located on the backside of the burner below the spark igniter. A small valve is provided at this test port.

14. Connect a manometer or other suitable device to the heat exchanger draft port located on the side of the AHU near the burner. The expected draft should read slightly negative about -0.03 inches WC. The draft port is typically made of 3/4 in steel pipe and may be plugged. Remove plug and add a small stop valve and a nipple for a rubber tube.
15. Install the Honeywell S7800 Test Module, if available.
16. Connect the signal generator (0-20mA) to terminals in place of modulation control signal (for 2-10 VDC signal add a 500 Ω resistor in series).
17. Visually check that the flue (stack) is secure and connected properly. Typical connections are shown at the end of these instructions.
18. The burner panel's on/off switch should be off.
19. The system is now ready for start up.

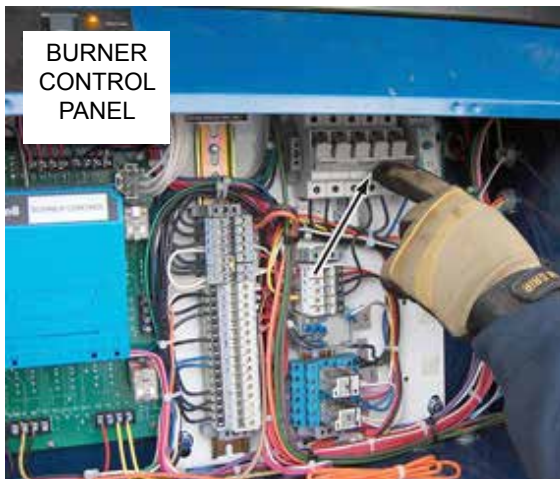

LD12903

FIGURE 29 - OPEN FUSE DISCONNECTS



LD12910

FIGURE 30 - SET ID FAN DAMPER

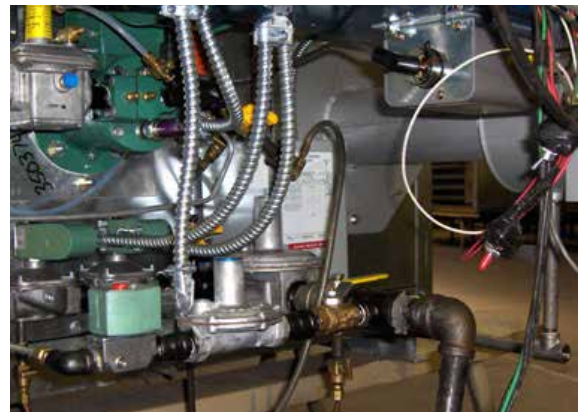

LD12905

FIGURE 31 - CHECK MAIN GAS SUPPLY PRESSURE

Starting the Burner

1. Prior to starting the burner, the technician must verify the incoming gas pressure. A minimum pressure is listed on the burner test report. The maximum pressure is listed as well.
2. Open the manual gas valves on gas supply and pilot line.
3. Initiate a call for heat or use jumper to create a call for heat.
4. Turn the burner panel on/off switch to on.
5. Once there is a call for heat, a 30-second pre-purge period is initiated to remove any gases from the heat exchanger. The burner will go through a second purge before ignition.
6. The burner will automatically go to low fire at start-up. After proof of low fire, the burner will modulate up to high fire, which may take 15 seconds for a Powerflame burner, and 90-180 seconds for the Eclipse burner. After the burner operates at High Fire use the manometer connected to the Heat Exchanger Draft Port as shown in *Figure 32 on page 38*, observe the reading. A pressure of -0.03 inches WC is expected for draft overfire. Readings may differ slightly from those shown on the Burner Test Report.
7. For valid readings before making any adjustments, allow the burner to fire at least 20 minutes to allow the heat exchanger to rise to the operating temperature.
8. Observe the gas manifold pressure and compare to the data on the Burner Test Report under both high and low fire conditions.

9. Check the flue (stack) combustion temperature at the ID blower housing test port. Make sure the test probe is inserted halfway into the ID inlet tube as shown in *Figure 33 on page 38*. Compare the results to the Burner Test Report.
10. The ignition transformer is intermittent. Pilot continues to burn after ignition transformer is de-energized.
11. Using the signal generator, cycle the burner to check capacity modulation. Observe valve/damper actuator operation as shown in *Figure 34 on page 38*.
12. Using the standard operating controls, cycle the burner several times to assure proper sequencing of start-up, firing, and capacity modulation, plus operation of all safety and monitoring controls.
13. Test the 180°F high temperature safety by running the burner with the airflow off or diverted. The burner will shut down at 180°F. Turn the AHU on as quickly as possible to remove the heat from the heat exchanger.
14. Test the burner efficiency last. The burner should be running at high fire rate for 30 minutes before efficiency testing is done.
15. Efficiency at high fire is pre-determined, but may be checked by flue gas analysis at the entrance to the ID Blower Housing Test Port. At high fire, the CO₂ should be between 8-1/2% and 10%; the O₂ should be between 7-1/2% and 4%. With these ranges, efficiency is 80% plus or minus 2% as shown in *Figure 33 on page 38*.
16. Contact the contractor, facilities manager or customer to inform them that the start-up was completed successfully.
17. In the unlikely event that adjustment is required; it is done at high fire and must **NOT** retard low fire light-off.



Do not change the set up of factory pre-set air inlet dampers on the power flame burner.

18. Direct any questions to the Johnson Controls Field Service Office or Product Technical Support before contacting the burner manufacturer.

19. When operated at low fire for extended periods, more condensate is generated and with it deposits of solids in the condensate drainage system.
20. Provide the ability to prime the trap. During initial and seasonal start up, trap inspection and priming is required. Condensate in the trap will evaporate during long periods of non-use.
21. Trap and drainage system should be cleaned annually.



LD12908

FIGURE 32 - DRAFT OVER FIRE TEST PORT



LD12906

FIGURE 33 - FLUE COMBUSTION TEMPERATURE AND EFFICIENCY TEST PORT- ID BLOWER



LD12909

FIGURE 34 - DAMPER ACTUATOR

TABLE 5 - GAS HEAT SEGMENT MODEL NUMBER NOMENCLATURE

B	100	U	3	L	G	G	A	A	A
REV	DF SIZE/ CAPACITY MBH	CODE COMPLIANCE	BURNER TDR	AHU HAND DESIGNATION	ID FAN HSG		CONTROL VOLTAGE (T*STAT VOLT- AGE)	BURNER MOD CONTROL	
A	15	A	3	L	G	Galvanized	A	A	2-10 VDC
B	20	U	10	R	S	Stainless	B	B	4-20 mA
C	25	F	25				C	C	0-135 Ohms
	30	R					D		
	35						E		
	40						F		
	45						G		
	50						H		
	60						J		
	75						K		
	85								
	100								
	125								
	150								
	175								
	200								
	225								
	250								
	275								
	300								
	325								
	350								
	375								
	400								

GAS { GAS LP = 2,500 BTU/ CU FT.
 NATURAL = 1,000 BTU/ CU FT.
 Output is approx. 80% of input BTUs

TABLE 6 - NATURAL GAS PRESSURE REQUIREMENTS (INCHES WC)

NOMENCLATURE FEATURE	MAXIMUM ALLOWABLE INLET PRESSURE										MINIMUM INLET PRESSURE TO FIRE													
	A03	U03	F03	R03	A10	U10	F10	R10	A25	U25	F25	R25	A03	U03	F03	R03	A10	U10	F10	R10	A25	U25	F25	R25
OPTION	GAS BURNER PIPING/GAS BURNER TD										GASBURNER PIPING/ AS BURNER TD													
GAS BTUS	ANSI 3	UL 3	FM 3	IRI 3	ANSI 10	UL 10	FM 10	IRI 10	ANSI 25	UL 25	FM 25	IRI 25	ANSI 3	UL 3	FM 3	IRI 3	ANSI 10	UL 10	FM 10	IRI 10	ANSI 25	UL 25	FM 25	IRI 25
FUR-NACE OUTPUT (X10K)	ANSI 3:1	UL 3:1	FM 3:1	IRI 3:1	ANSI 10:1	UL 10:1	FM 10:1	IRI 10:1	ANSI 25:1	UL 25:1	FM 25:1	IRI 25:1	ANSI 3:1	UL 3:1	FM 3:1	IRI 3:1	ANSI 10:1	UL 10:1	FM 10:1	IRI 10:1	ANSI 25:1	UL 25:1	FM 25:1	IRI 25:1
015	14	N/A	N/A	N/A	27	N/A	N/A	N/A	N/A	N/A	N/A	N/A	4	N/A	N/A	N/A	13	N/A	N/A	N/A	N/A	N/A	N/A	N/A
020	14	N/A	N/A	N/A	27	N/A	N/A	N/A	N/A	N/A	N/A	N/A	4	N/A	N/A	N/A	13	N/A	N/A	N/A	N/A	N/A	N/A	N/A
025	14	N/A	N/A	N/A	27	N/A	N/A	N/A	N/A	N/A	N/A	N/A	4	N/A	N/A	N/A	13	N/A	N/A	N/A	N/A	N/A	N/A	N/A
030	14	N/A	N/A	N/A	27	N/A	N/A	N/A	N/A	N/A	N/A	N/A	4	N/A	N/A	N/A	13	N/A	N/A	N/A	N/A	N/A	N/A	N/A
035	N/A	14	N/A	27	N/A	27	N/A	27	N/A	27	N/A	27	N/A	5	NA	4	N/A	4	N/A	4	N/A	4	N/A	18
040	N/A	14	N/A	27	N/A	27	N/A	27	N/A	27	N/A	27	N/A	5	NA	5	N/A	5	N/A	5	N/A	5	N/A	18
045	N/A	14	N/A	27	N/A	27	N/A	27	N/A	27	N/A	27	N/A	5	NA	5	N/A	5	N/A	5	N/A	5	N/A	18
050	N/A	14	N/A	27	N/A	27	N/A	27	N/A	27	N/A	27	N/A	5	NA	5	N/A	5	N/A	5	N/A	5	N/A	18
060	N/A	27	N/A	27	N/A	27	N/A	27	N/A	27	N/A	27	N/A	6	NA	6	N/A	6	NA	6	N/A	6	NA	19
075	N/A	27	N/A	27	N/A	27	N/A	27	N/A	27	N/A	27	N/A	6	NA	7	N/A	6	NA	7	N/A	6	NA	19
085	N/A	27	N/A	27	N/A	27	N/A	27	N/A	27	N/A	27	N/A	9	NA	8	N/A	9	NA	8	N/A	9	NA	19
100	N/A	27	N/A	27	N/A	27	N/A	27	N/A	27	N/A	27	N/A	11	NA	9	N/A	11	NA	9	N/A	11	NA	20
125	N/A	27	N/A	27	N/A	27	N/A	27	N/A	27	N/A	27	N/A	8	NA	7	N/A	8	NA	7	N/A	8	NA	20
150	N/A	27	N/A	27	N/A	27	N/A	27	N/A	27	N/A	27	N/A	11	NA	9	N/A	11	NA	9	N/A	11	NA	20
175	N/A	27	N/A	27	N/A	27	N/A	27	N/A	55	N/A	55	N/A	15	NA	12	N/A	15	NA	12	N/A	15	NA	34
200	N/A	27	N/A	27	N/A	27	N/A	27	N/A	55	N/A	55	N/A	15	NA	12	N/A	15	NA	12	N/A	15	NA	38
225	N/A	N/A	27	27	N/A	N/A	27	27	N/A	N/A	55	55	N/A	N/A	8	11	N/A	N/A	8	11	N/A	N/A	34	34
250	N/A	N/A	27	27	N/A	N/A	27	27	N/A	N/A	55	55	N/A	N/A	8	11	N/A	N/A	8	11	N/A	N/A	35	35
275	N/A	N/A	27	27	N/A	N/A	27	27	N/A	N/A	55	55	N/A	N/A	11	10	N/A	N/A	11	10	N/A	N/A	39	39
300	N/A	N/A	27	27	N/A	N/A	27	27	N/A	N/A	55	55	N/A	N/A	11	11	N/A	N/A	11	11	N/A	N/A	40	40
325	N/A	N/A	27	27	N/A	N/A	27	27	N/A	N/A	55	55	N/A	N/A	8	9	N/A	N/A	8	9	N/A	N/A	41	41
350	N/A	N/A	27	27	N/A	N/A	27	27	N/A	N/A	55	55	N/A	N/A	8	9	N/A	N/A	8	9	N/A	N/A	48	48
375	N/A	N/A	27	27	N/A	N/A	27	27	N/A	N/A	55	55	N/A	N/A	8	10	N/A	N/A	8	10	N/A	N/A	49	49
400	N/A	N/A	27	27	N/A	N/A	27	27	N/A	N/A	55	55	N/A	N/A	9	10	N/A	N/A	9	10	N/A	N/A	48	48

Note: Gas pressure requirements at the inlet to the main manual shutoff cock of the gas train.

TABLE 7 - NATURAL GAS PRESSURE REQUIREMENTS (INCHES WC)

NOMENCLATURE FEATURE	MAXIMUM ALLOWABLE INLET PRESSURE														MINIMUM INLET PRESSURE TO FIRE													
	A03	U03	F03	R03	A10	U10	F10	R10	A25	U25	F25	R25	A03	U03	F03	R03	A10	U10	F10	R10	A25	U25	F25	R25				
OPTION	GAS BURNER PIPING/GAS BURNER TD														GASBURNER PIPING/AS BURNER TD													
	ANSI 3	UL 3	FM 3	IRI 3	ANSI 10	UL 10	FM 10	IRI 10	ANSI 25	UL 25	FM 25	IRI 25	ANSI 3	UL 3	FM 3	IRI 3	ANSI 10	UL 10	FM 10	IRI 10	ANSI 25	UL 25	FM 25	IRI 25				
FUR- NACE OUTPUT (X10K)	ANSI 3:1	UL 3:1	FM 3:1	IRI 3:1	ANSI 10:1	UL 10:1	FM 10:1	IRI 10:1	ANSI 25:1	UL 25:1	FM 25:1	IRI 25:1	FURNACE OUTPUT (X10K)	ANSI 3:1	UL 3:1	FM 3:1	IRI 3:1	ANSI 10:1	UL 10:1	FM 10:1	IRI 10:1	ANSI 25:1	UL 25:1	FM 25:1	IRI 25:1			
015	14	N/A	N/A	N/A	27	N/A	N/A	N/A	N/A	N/A	N/A	N/A	015	N/A	N/A	N/A	N/A	N/A	N/A	N/A	N/A	N/A	N/A	N/A				
020	14	N/A	N/A	N/A	27	N/A	N/A	N/A	N/A	N/A	N/A	N/A	020	N/A	N/A	N/A	N/A	N/A	N/A	N/A	N/A	N/A	N/A	N/A				
025	14	N/A	N/A	N/A	27	N/A	N/A	N/A	N/A	N/A	N/A	N/A	025	N/A	N/A	N/A	N/A	N/A	N/A	N/A	N/A	N/A	N/A	N/A				
030	14	N/A	N/A	N/A	27	N/A	N/A	N/A	N/A	N/A	N/A	N/A	030	N/A	N/A	N/A	N/A	N/A	N/A	N/A	N/A	N/A	N/A	N/A				
035	N/A	14	N/A	27	N/A	27	N/A	27	N/A	27	N/A	27	035	N/A	5	NA	4	N/A	4	N/A	4	N/A	4	N/A				
040	N/A	14	N/A	27	N/A	27	N/A	27	N/A	27	N/A	27	040	N/A	5	NA	5	N/A	5	N/A	5	N/A	5	N/A				
045	N/A	14	N/A	27	N/A	27	N/A	27	N/A	27	N/A	27	045	N/A	5	NA	5	N/A	5	N/A	5	N/A	5	N/A				
050	N/A	14	N/A	27	N/A	27	N/A	27	N/A	27	N/A	27	050	N/A	5	NA	5	N/A	5	N/A	5	N/A	5	N/A				
060	N/A	27	N/A	27	N/A	27	N/A	27	N/A	27	N/A	27	060	N/A	6	NA	6	N/A	6	NA	6	N/A	6	NA				
075	N/A	27	N/A	27	N/A	27	N/A	27	N/A	27	N/A	27	075	N/A	6	NA	7	N/A	7	NA	7	N/A	7	NA				
085	N/A	27	N/A	27	N/A	27	N/A	27	N/A	27	N/A	27	085	N/A	9	NA	8	N/A	8	NA	8	N/A	8	NA				
100	N/A	27	N/A	27	N/A	27	N/A	27	N/A	27	N/A	27	100	N/A	11	NA	9	N/A	9	NA	9	N/A	9	NA				
125	N/A	27	N/A	27	N/A	27	N/A	27	N/A	27	N/A	27	125	N/A	8	NA	7	N/A	7	NA	7	N/A	7	NA				
150	N/A	27	N/A	27	N/A	27	N/A	27	N/A	27	N/A	27	150	N/A	11	NA	9	N/A	9	NA	9	N/A	9	NA				
175	N/A	27	N/A	27	N/A	27	N/A	27	N/A	27	N/A	27	175	N/A	15	NA	12	N/A	12	NA	12	N/A	12	NA				
200	N/A	27	N/A	27	N/A	27	N/A	27	N/A	27	N/A	27	200	N/A	15	NA	12	N/A	12	NA	12	N/A	12	NA				
225	N/A	N/A	27	27	N/A	N/A	27	27	N/A	N/A	27	27	225	N/A	N/A	8	11	N/A	8	11	N/A	8	11	N/A				
250	N/A	N/A	27	27	N/A	N/A	27	27	N/A	N/A	27	27	250	N/A	N/A	8	11	N/A	8	11	N/A	8	11	N/A				
275	N/A	N/A	27	27	N/A	N/A	27	27	N/A	N/A	27	27	275	N/A	N/A	11	10	N/A	11	10	N/A	11	10	N/A				
300	N/A	N/A	27	27	N/A	N/A	27	27	N/A	N/A	27	27	300	N/A	N/A	11	11	N/A	11	11	N/A	11	11	N/A				
325	N/A	N/A	27	27	N/A	N/A	27	27	N/A	N/A	27	27	325	N/A	N/A	8	9	N/A	8	9	N/A	8	9	N/A				
350	N/A	N/A	27	27	N/A	N/A	27	27	N/A	N/A	27	27	350	N/A	N/A	8	9	N/A	8	9	N/A	8	9	N/A				
375	N/A	N/A	27	27	N/A	N/A	27	27	N/A	N/A	27	27	375	N/A	N/A	8	10	N/A	8	10	N/A	8	10	N/A				
400	N/A	N/A	27	27	N/A	N/A	27	27	N/A	N/A	27	27	400	N/A	N/A	9	10	N/A	9	10	N/A	9	10	N/A				

Note: Gas pressure requirements at the inlet to the main manual shutoff cock of the gas train.

TABLE 8 - INLET SIZE (NPT)

	A03	U03	F03	R03	A10	U10	F10	R10	A25	U25	F25	R25
	GAS BURNER PIPING/GAS BURNER TURN DOWN											
	ANSI 3	UL 3	FM 3	IRI 3	ANSI 10	UL 10	FM 10	IRI 10	ANSI 25	UL 25	FM 25	IRI 25
FURNACE OUTPUT (X10K)	ANSI 3:1	UL 3:1	FM 3:1	IRI 3:1	ANSI 10:1	UL 10:1	FM 10:1	IRI 10:1	ANSI 25:1	UL 25:1	FM 25:1	IRI 25:1
015	0.75	NA	NA	NA	1.00	NA	NA	NA	NA	NA	NA	NA
020	0.75	NA	NA	NA	1.00	NA	NA	NA	NA	NA	NA	NA
025	0.75	NA	NA	NA	1.00	NA	NA	NA	NA	NA	NA	NA
030	0.75	NA	NA	NA	1.00	NA	NA	NA	NA	NA	NA	NA
035	NA	1.00	NA	1.00	NA	1.00	NA	1.00	NA	NA	NA	NA
040	NA	1.00	NA	1.00	NA	1.00	NA	1.00	NA	1.00	NA	1.00
045	NA	1.00	NA	1.00	NA	1.00	NA	1.00	NA	1.00	NA	1.00
050	NA	1.00	NA	1.00	NA	1.00	NA	1.00	NA	1.00	NA	1.00
060	NA	1.00	NA	1.00	NA	1.00	NA	1.00	NA	1.00	NA	1.00
075	NA	1.00	NA	1.00	NA	1.00	NA	1.00	NA	1.25	NA	1.25
085	NA	1.00	NA	1.00	NA	1.00	NA	1.00	NA	1.25	NA	1.25
100	NA	1.00	NA	1.00	NA	1.00	NA	1.00	NA	1.25	NA	1.25
125	NA	1.25	NA	1.25	NA	1.25	NA	1.25	NA	1.50	NA	1.50
150	NA	1.25	NA	1.25	NA	1.25	NA	1.25	NA	1.50	NA	1.50
175	NA	1.25	NA	1.25	NA	1.25	NA	1.25	NA	1.50	NA	1.50
200	NA	1.50	NA	1.50	NA	1.50	NA	1.50	NA	1.50	NA	1.50
225	NA	NA	2.00	1.50	NA	NA	2.00	1.50	NA	NA	2.00	2.00
250	NA	NA	2.00	1.50	NA	NA	2.00	1.50	NA	NA	2.00	2.00
275	NA	NA	2.00	1.50	NA	NA	2.00	2.00	NA	NA	2.00	2.00
300	NA	NA	2.00	1.50	NA	NA	2.00	2.00	NA	NA	2.00	2.00
325	NA	NA	2.50	2.50	NA	NA	2.50	2.50	NA	NA	2.50	2.50
350	NA	NA	2.50	2.50	NA	NA	2.50	2.50	NA	NA	2.50	2.50
375	NA	NA	2.50	2.50	NA	NA	2.50	2.50	NA	NA	2.50	2.50
400	NA	NA	2.50	2.50	NA	NA	2.50	2.50	NA	NA	2.50	2.50

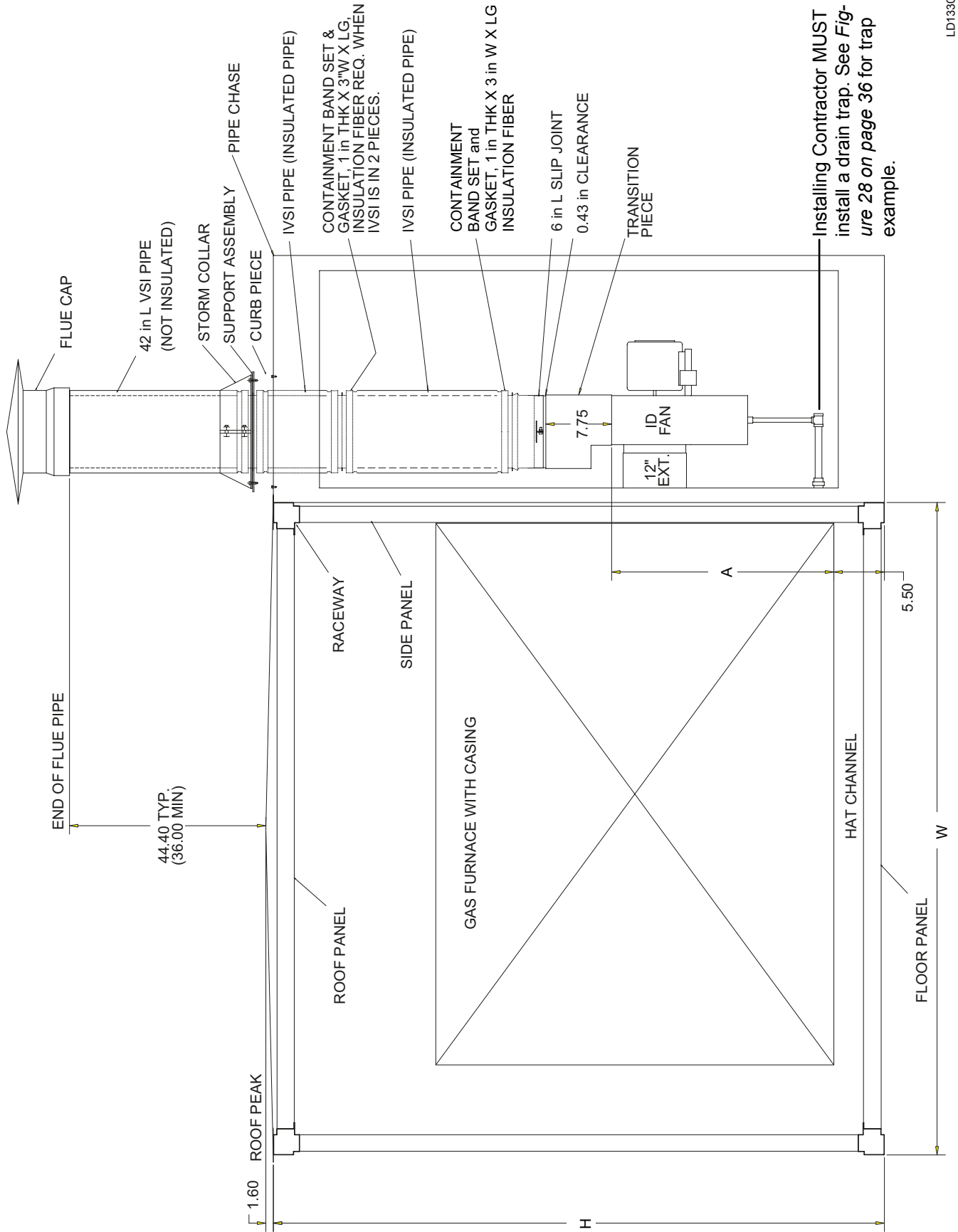

LD13304

FIGURE 35 - EXAMPLE SOLUTION XT GAS FURNACE FUEL VENTING SYSTEM

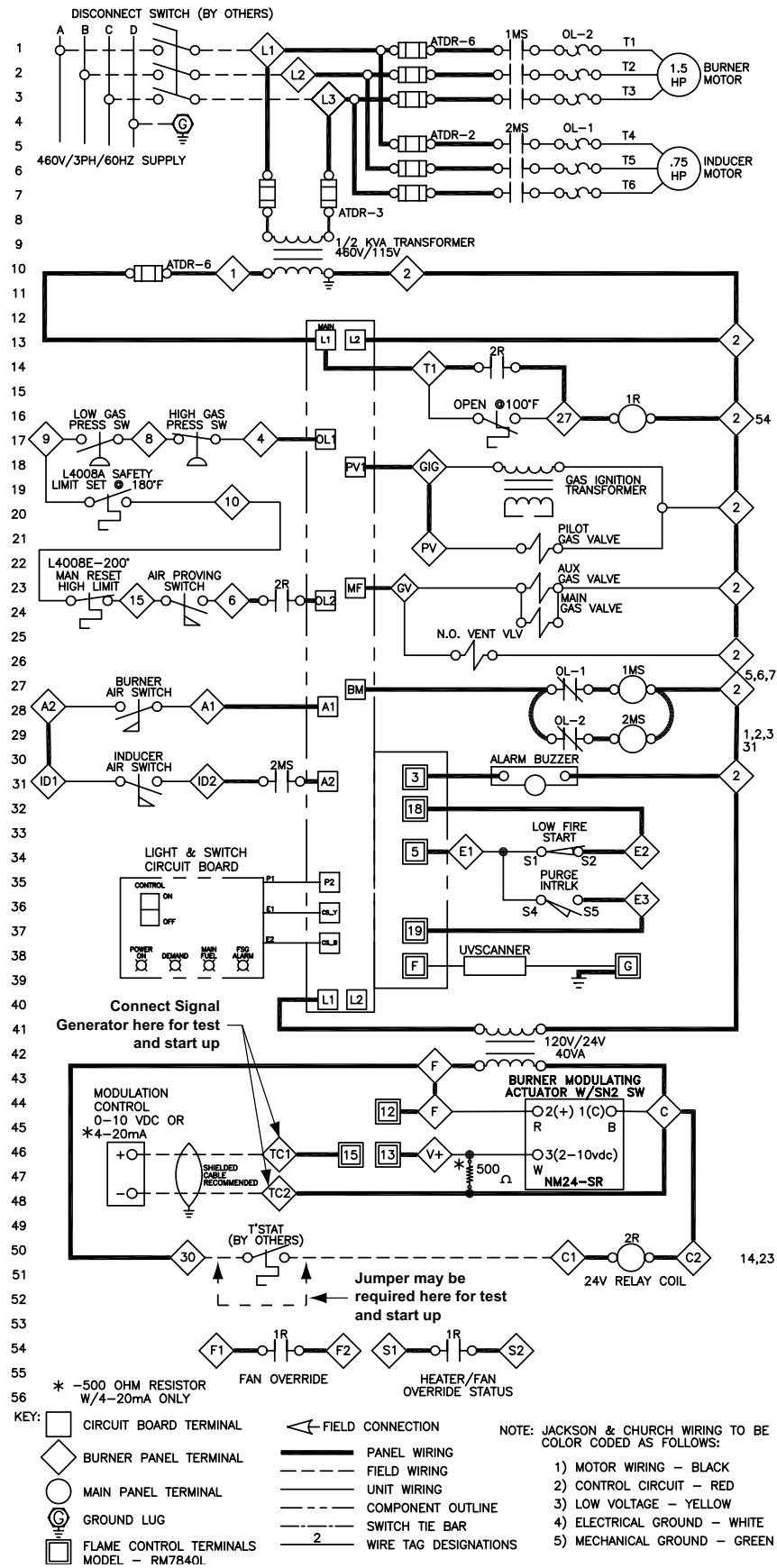

LD13315

FIGURE 36 - TYPICAL WIRING DIAGRAM

TABLE 9 - BURNER TEMPERATURE RISE

CFM	TEMPERATURE RISE (°F)			INTERNAL PRESSURE DROP WC
	DF-15	DF-20	DF-25	
1,500	91	--	--	0.17
2,000	68	91	--	0.29
2,500	55	73	91	0.46
3,000	46	61	76	0.65
3,500	40	52	65	0.89
4,000	35	46	57	1.17
4,500	31	41	51	1.47
5,248	26	35	44	2
	DF-30	DF-20	DF-25	
3,000	95	--	--	0.22
3,500	82	91	--	0.31
4,000	71	79	95	0.41
4,500	63	70	85	0.54
5,000	57	63	76	0.66
5,500	52	57	69	0.84
6,000	47	53	63	1
6,500	43	47	58	1.2
7,000	40	46	54	1.45
8,440	32.9	38.4	43.9	2
	DF-45	DF-50		
4,500	88	--		0.39
5,000	80	90		0.47
5,500	72	82		0.55
6,000	66	75		0.65
6,500	61	69		0.75
7,000	57	64		0.86
7,500	53	60		0.98
8,000	50	56		1.1
8,500	47	53		1.23
9,000	46	50		1.38
10,725	38.8	43.2		2
	DF-60	DF-75		
6,000	91	--		0.44
6,500	84	--		0.52
7,000	78	--		0.6
7,500	73	91		0.68
8,000	68	85		0.78
9,000	61	76		0.98
10,000	55	68		1.2
11,000	50	62		1.4
12,000	46	57		1.7
12,900	43	53.8		2

TABLE 9 - BURNER TEMPERATURE RISE (CONT'D)

CFM	TEMPERATURE RISE (°F)		INTERNAL PRESSURE DROP WC
	DF-85	DF-100	
8,500	91	--	0.47
9,000	86	--	0.52
9,500	81	--	0.58
10,000	77	91	0.64
10,500	74	87	0.7
11,000	70	83	0.76
12,000	64	76	0.9
13,000	59	70	1.05
14,000	55	65	1.25
15,000	51	61	1.4
16,000	49	57	1.6
17,000	46	54	1.75
17,825	44	52	2
	DF-125	DF-150	
13,000	89	--	0.48
14,000	83	--	0.56
15,000	77	93	0.65
16,000	72	87	0.73
17,000	68	82	0.82
18,000	64	77	0.92
19,000	61	73	1.03
20,000	58	69	1.13
21,000	55	66	1.25
22,000	52	63	1.35
23,000	50	60	1.5
24,000	48	58	1.3
25,000	46	55	1.75
26,315	43.6	52	2

2

TABLE 9 - BURNER TEMPERATURE RISE (CONT'D)

CFM	TEMPERATURE RISE (°F)				INTERNAL PRESSURE DROP WC
	DF- 175	DF- 200			
17,000	95	--			0.45
18,000	90	--			0.52
19,000	85	--			0.57
20,000	81	93			0.63
21,000	77	88			0.7
22,000	74	85			0.76
23,000	71	81			0.82
24,000	68	78			0.9
26,000	62	71			1.05
28,000	58	66			1.25
30,000	54	62			1.4
32,000	51	58			1.6
34,000	48	54			1.8
35,635	45.5	52			2
	DF- 225	DF- 250	DF- 275	DF- 300	
24,000	87	--	--	--	0.337
27,000	77	86	92.5	--	0.427
30,000	69	77	83.3	90.8	0.527
33,000	63	70	75.8	82.5	0.637
36,000	58	64	69.5	75.7	0.758
39,000	53	59	64	70	0.89
42,000	50	55	59.5	65	1.035
45,000	46	51	55.6	60.6	1.185
48,000	43	48	52.1	55.8	1.35
51,000	41	45	50	53.5	1.525
54,000	39	43	47	50.5	1.71
58,475	35	39.5	43.5	47.5	2
	DF- 325	DF- 350	DF- 375	DF- 400	
31,565	95	--	--	--	0.4
35,290	85	92	--	--	0.5
41,755	72	78	83	89	0.7
47,345	64	68	73	78	0.9
52,340	57	62	66	71	1.1
54,665	55	59	64	68	1.2
59,045	51	55	59	63	1.4
63,125	48	51	55	59	1.6
66,950	45	48	52	55	1.8
70,573	42.6	45.9	49.2	52.4	2

Starting the Electric Heater

Rotating parts and electrical shock hazards exist. Lock out and tag out the fan motor(s) and heat power disconnects before servicing. FOLLOW THE LATEST "LOCKOUT TAGOUT" PROCEDURE. Failure to follow proper safety precautions may result in serious injury or death.

Application Information

1. Follow the procedure given in this instruction to find the minimum air velocity for safe operation (see Fig. 1). At least this minimum velocity must be provided at all points over the heater face area. Failure to meet this requirement may result in serious damage or nuisance thermal cutout tripping.
2. The maximum air inlet temperature for open coil heaters is 100°F, and for finned tubular heaters, 80°F.
3. Sufficient working space must be provided per paragraph 110-26 of the National Electrical Code (NEC).
4. This electric heater is not designed for or intended to be used for temporary heat prior to system startup / balancing.

Mechanical Installation

1. All heaters will contain an adjustable airflow switch in the heater control panel. This switch will be preset to close at a differential pressure of approximately 0.3" W.C. In all cases the switch will be connected to a pressure probe positioned in the airstream. This probe has an arrow stamped on it that is viewable from inside of the control panel. When the heater is located upstream of the fan this arrow will point away from the fan. When the heater is located on the downstream side of the fan the arrow will again point away from the fan or with airflow. If it is incorrectly installed, remove the two screws holding the pressure probe in place and rotate 180° and reinstall. The airflow switch pressure port that is not connected to this pressure probe will be run to the exterior of the air handling unit to source a reference differential pressure. In some situations it may be necessary to adjust this airflow switch setting to allow for proper operation. Precautions must be made at this time to make sure that the airflow switch does not provide a false indication of airflow. Failure to meet this requirement may result in serious dam-

age or nuisance thermal cutout tripping.

2. A visual inspection of the heater elements should be made prior to use of the heater. If physical damage is evident, a Megohm test should be used to validate the heater elements are safe for use. If a minimum value of 10 megohms is not achieved then any damaged elements or ceramic insulators must be replaced prior to operation.

Electrical Installation

1. Follow the wiring diagram on the inside of the terminal box.
2. Supply connections must be made with copper wiring rated for 75°C minimum.
3. If supply connections are for 250 volts or greater, all wiring must be insulated for 600 volts.
4. When making line connections to heater element terminals FOR FINNED TUBULAR HEATERS ONLY, apply a 1/4" wrench to flat section of terminal immediately below threads. Otherwise damage to terminal may result.
5. Supply conductors for heaters rated less than 50 KW, must be sized at 125% of rated load. On heaters rated 50 KW and more, the supply conductors may be sized at 100% of rated load, if indicated on the wiring diagram. The line current for either a single or three phase load is calculated as follows:

$$\text{Single Phase Line Current} = \frac{\text{KW} \times 1000}{\text{Voltage}}$$

$$\text{Three Phase Line Current} = \frac{\text{KW} \times 1000}{\text{Voltage} \times 1.73}$$

6. The following table shows the maximum current for 75°C copper wire with not more than three conductors in a raceway. It is based on the NEC Table 310-16. The amperages shown are for 125% and 100% wire sizing. If there are more than three conductors in a raceway, derate these amperages

per NEC Table 310-15(b)(2)(a).

TABLE 10 - MAXIMUM CURRENT FOR 75°C COPPER WIRE

AMPS		Wire Size Awg/ MCM	AMPS		Wire Size Awg/ MCM	AMPS		Wire Size Awg/ MCM
125%	100%		125%	100%		125%	100%	
12		14	80	100	3	184	203	4/0
16		12	92	115	2	204	255	250
24		10	104	130	1	228	285	300
40		8	120	150	0	248	310	350
52	65	6	140	175	2/0	268	335	400
68	85	4	160	200	3/0	304	380	500

7. When connecting heaters with more than one stage, wire stage No. 1 so that it is the first stage on and the last stage off.
8. The heater must be wired so that it cannot operate unless air is flowing over it. This can be accomplished by using a built-in airflow switch and a remote interlock. See the accompanying wiring diagram for the method used with this heater and provide appropriate interlock wiring as illustrated. This diagram will be located inside of the electric heater control panel.
9. If not supplied as part of this heater, install a line disconnect switch or main circuit breaker in accordance with the NEC. Depending upon the heater's location and accessibility, a built-in disconnect switch may meet this requirement.
10. All electrical connections in the heater, including both field and factory made connections, should be checked for tightness before operating the heater. In addition, after a short period of operation, all connections should again be checked for tightness.
11. If heater is wired to a heating / cooling thermostat, use a thermostat with isolating circuits to prevent possible interconnection of Class 2 outputs.
12. If the heating elements are divided into several sections with resistance wire between two or more sections, maximum KW per sq. ft. should be calculated as follows:

$$\sqrt{\frac{\text{Heater nameplate KW}}{\text{Number of heated sections} \times \text{area of one heated section}}}$$

AIR FLOW REQUIREMENTS

Calculate KW per square foot of duct area as: $\frac{\text{heater nameplate KW}}{\text{duct area (Sq.Ft.)}}$ (see step 12)

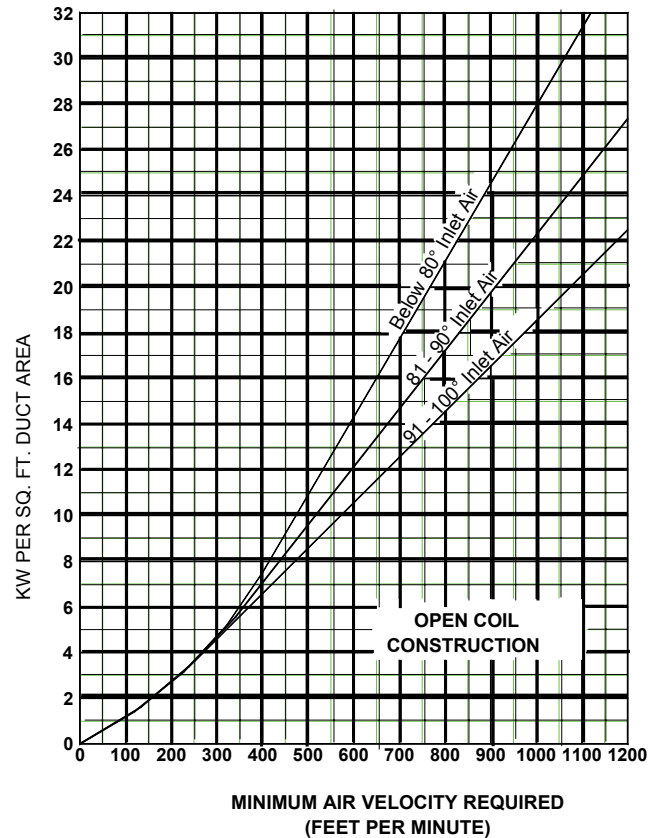
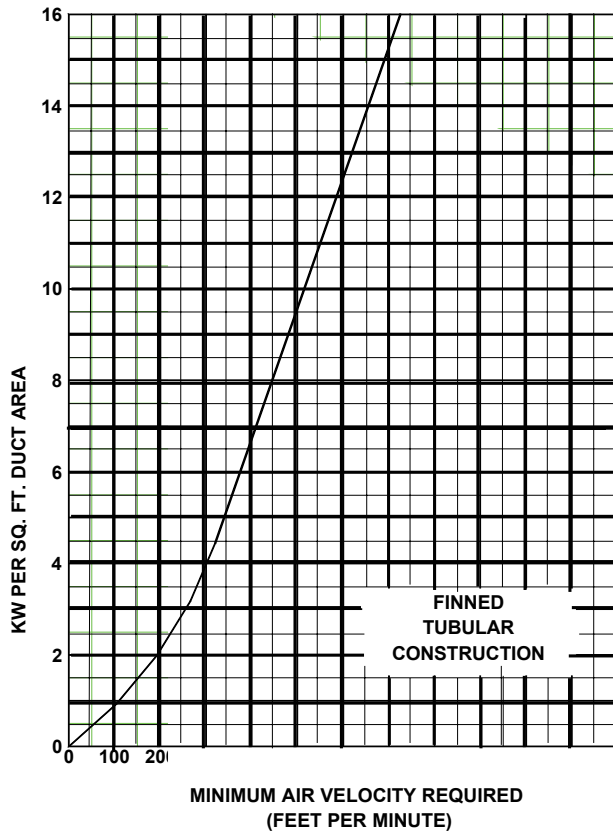

FIGURE 37 - MINIMUM AIR VELOCITY REQUIRED FOR SAFE OPERATION

Starting The Electric Heater



Rotating parts and electrical shock hazards exist. Use the latest lock out/tag out procedure to the fan motor(s) and heat power disconnects before servicing. Failure to follow proper safety precautions may result in serious injury or death.

Use the following instructions to start up the electrical heater.

1. Check all electrical connections in the heater, including both field and factory installed connections, for tightness before operating the heater. After a short period of operation, check all connections again for tightness.



DO NOT operate electric heat below the minimum airflow requirement.

2. Visually inspect the heater elements prior to using the heater. If physical damage is evident, use a Megohm test to validate that the heater elements are safe to use. If a less than 10 megohms is achieved, replace any damaged elements or ceramic insulators prior to operation.
3. Ensure filters are clean, and airflow is at the minimum requirement or greater, preferably 100 % airflow for this start up procedure.
4. Make sure all associated control equipment is turned on.
5. Energize main supply disconnect and set controlling thermostat above ambient temperature.
6. This heater is equipped with automatic and manual reset temperature limiting controls. If it fails to operate, make sure the manual resets are operative by pushing reset buttons.

TOP VIEW OF UNIT

POSITIVE PRESSURE / AIR BLOWN THROUGH HEATER

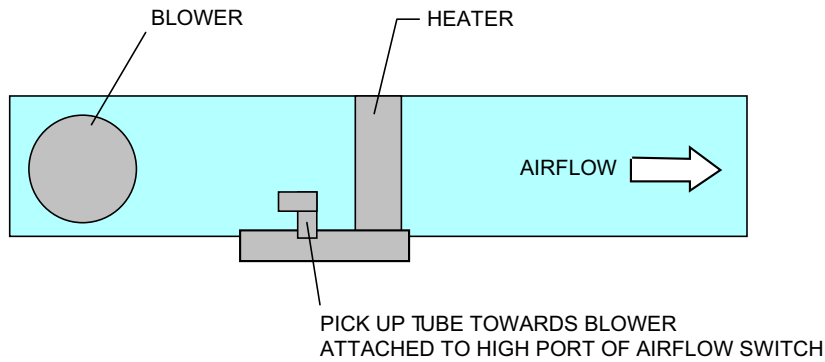

NEGATIVE PRESSURE / AIR DRAWN THROUGH HEATER

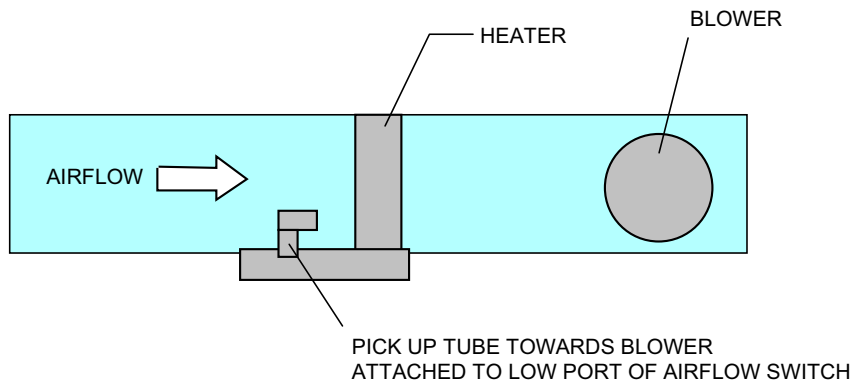

LD14268

FIGURE 38 - PRESSURE PROBE DIRECTION

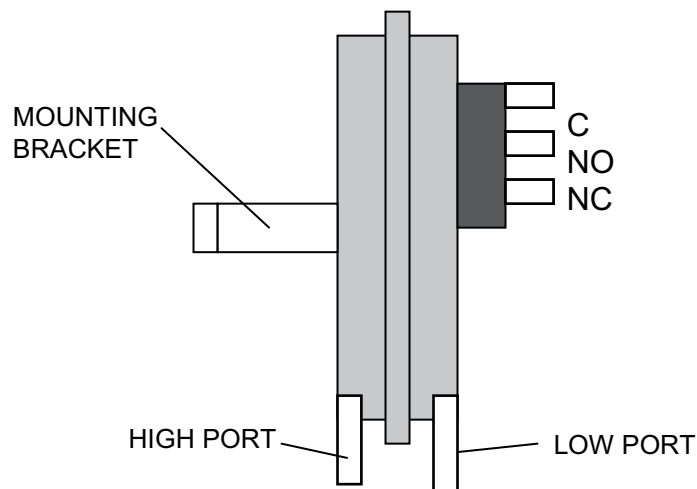

LD14270

FIGURE 39 - AIR FLOW SWITCH CONNECTIONS

OPERATION

DO NOT penetrate wireways in any manner. These sheet metal channels, which run along the top panel, contain electrical wires and connections. Electrical shock and/or damage to the AHU may result.



Rotating parts and electrical shock hazards exist. Follow the latest lockout/tag out procedures to lockout/tagout the fan motor(s) and heat power disconnects before servicing. Failure to follow proper safety precautions may result in serious injury or death. Refer to general safety guidelines and safety symbols located at the front of this manual.



Always replace RED metal tab on access doors that provide access to moving parts. This mechanical protection from moving parts is required by UL-1995.

Always replace RED metal tab on access doors that provide access to pressurized areas. This mechanical protection is to prevent accidental release of access doors under positive pressure.

Verify conformance with the total outdoor airflow and space supply airflow requirements of *ASHRAE Standard 111*, *SMACNA's HVAC Systems - Testing, Adjusting and Balancing*, 2nd edition, or equivalent.



Do not weld or use torches on the exterior or interior of the AHU housing. The housing contains polyurethane insulation, which, when under combustion, will produce harmful, toxic gases resulting in personal injury or death.

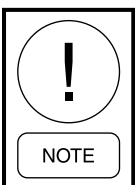

Never use silicone caulk/sealant or caulk/sealant containing silicone in or on solution air handling equipment.

Test And Balance**Air Balance**

- System air balance should be performed as soon as possible after AHU start-up.

- Failure to perform air balance may result in damage to AHU, generate noise vibration and condensation carryover.
- Qualified air balance technician should perform air balance.

Dynamic Balance

- Dynamic balance has been performed at the factory on the fan assemblies. If any changes were made to the fan assembly (fan, motor, sheaves, belts, isolators, support structure) a vibration analysis must be performed and the fan assembly trim balanced if needed.
- Dynamic balance is affected by operation of the VFD. If a VFD is provided, refer to the caution warnings in the VFD start-up instructions in the VFD operator's manual. Make sure the skip frequencies (jump frequencies) are installed prior to operation of the motors for more than 30 minutes.
- Commercial performance line of product, only has fan balance if option is selected.

Setting Limits**Temperature**

- Cabinet Panels - 200°F
- Standard Motors with (Class B Insulation) - 104°F.
- Motors with Class F. Insulation - 140°F
- Power Wiring - 140°F
- Controls and Control Wiring - 140°F.
- Prefilters - 150°F.
- High Efficiency Filters - 180°F
- Variable Speed Drive - ABB Mfg. - 140°F
- Damper and Valve Actuators - 140°F
- Gasketing - 200°F
- Gan Bearings - 120°F (FC) , 180°F (AF)
- Foam - Flash Point - 415°F
- Energy Recovery Wheels
 - Thermotech - 140°F
 - Innergy tech - 122°F
 - NovelAire® Technologies - 200°F
 - Airxchange® - 170°F

Static Pressure

- Solution XT - Maximum design cabinet pressure is ± 8 in WC at 1% leakage.
- YORK Custom - Maximum design cabinet pressure is ± 10 in WC at 0.5% leakage.
- Access doors are double walled. Doors are provided with adjustable door latches and seals.

Checking Motors, Belts and Sheaves

Motors



Do not operate fan motors in overload amperage conditions. Motors are designed to operate within the stated Service Factor (SF) on the motor nameplate.

Motor amperage should be checked again after the connecting ductwork is installed, and an air balance is performed on the air distribution system. If the motor operates at amperage levels above the nameplate limits, discontinue operation and correct the cause, or refer to *SECTION 3 - MAINTENANCE* in this manual

Belts

Check belts for correct tension at start-up, and again after 24 hours of operation. On multiple belt adjustable pulleys, check the pitch depth to insure identical belt travel, power transfer and wear. Adjustable motor bases are provided for belt adjustment.

Sheaves

If optional adjustable sheaves are provided, replace them with correctly sized fixed sheaves immediately after the system air balance is performed. It is not unusual for an adjustable sheave to create damaging vibration in the fan assembly.

Replacing Sheaves

Use the following instructions to replace the sheaves.

1. Measure the outside diameter of a belt while it is seated into at least one half the circumference of an adjustable sheave groove, which is the sheave pitch diameter.

2. Order a good quality, pre-balanced sheave or sheave and bushing assembly that matches the pitch diameter, belt cross section, and bore size from Airside Parts at (800) 545-7814. Provide the following information:

- Drive tag information as shown in *Figure 40 on page 51*. On Solution XT AHUs, label will be located on the fan assembly near the belts.
- New fan RPM
- Measurement of pitch diameter at which the adjustable sheave is set.
- Job Identification Number from the AHU ID label.

A new driver (motor) sheave, or sheave and bushing are usually all that is required to directly replace the current adjustable driver sheave.



FIGURE 40 - V-BELT DRIVE KIT LABEL

P-Cone®

Operation of the P-Cone®

The P-Cone® has no moving parts; it cannot be turned on or off or adjusted. Each of the two piezometer rings on the exterior side of the inlet cone are fitted with a 0.25 union brass tee. The two tees are the connection points for running pneumatic tubing from the P-Cone® to an air pressure gauge/switch/readout. This P-Cone® will automatically produce a pressure differential signal whenever the fan is moving air.

THIS PAGE INTENTIONALLY LEFT BLANK.

SECTION 3 - MAINTENANCE

GENERAL REQUIREMENTS

The maintenance requirements for AHUs are shown below. The procedure is in the left-hand column, and the minimum required frequency is marked is described in the right-hand column.

Refer to *ANSI/ASHRAE Standard 62.1-2010* for start-up and maintenance practices related to achieving acceptable indoor air quality. *ANSI/ASHRAE Standard*

62.1-2010 is under continuous maintenance by a Standing Standard Project Committee (SSPC), for which the Standards Committee has established a documented program for regular publication of addenda or revisions, including procedures for timely, documented, consensus action on requests for change to any part of the standard as shown in *Table 11 on page 53*.

TABLE 11 - MINIMUM / MAINTENANCE REQUIREMENTS ACCORDING TO ASHRAE

PROCEDURE	EVERY 3 MONTHS	EVERY 6 MONTHS	ANNUALLY	EVERY 5 YEARS
Maintain filters and air cleaning devices.*	X			
Visually inspect or remotely monitor the outdoor air dampers and actuators for proper function.	X			
Clean and maintain humidifiers to limit fouling and microbial growth.	X			
Visually inspect the dehumidification coils for cleanliness and microbial growth. Clean when fouling is observed.			X	
Visually inspect drain pans and other adjacent surfaces subject to wetting for cleanliness and microbial growth and clean when fouling is observed		X		
Visually inspect outdoor air intake louvers, bird screens, mist eliminators, and adjacent areas for cleanliness and integrity. Clean, when necessary		X		
Verify sensors used for dynamic minimum outdoor air control accuracy and recalibrate or replace as necessary.		X		
Measure the minimum quantity of outdoor air in the AHUs except for AHUs under 1000 L/s (2000 CFM. If measured minimum airflow rates are less than 90% of the minimum outdoor rate in this manual. they shall be adjusted or modified to bring them above 90% or shall be evaluated to determine if the measured rates are in conformance with this ASHRAE standard.				X
Maintain the floor drains located in plenums or rooms that serve as air plenums to prevent transport of contaminants from the floor drain to the plenum.*			X	
Keep clear the space provided for routine maintenance and inspection around ventilation equipment for equipment component accessibility.*			X	
Investigate and rectify the visible microbial contamination.*			X	
Investigate and rectify the water intrusion or accumulation.*			X	

*Minimum frequencies may be increased or decreased from what is indicated in this table.

INSPECT PARTS

Inspect the following parts for damage, dirt and debris.

Cabinet

Clean the exterior of the AHU with a mild, environmental safe detergent and high-pressure water at 2000 psi.

Door Hardware and Gaskets

Inspect the doors, handles, latches and hinges for proper operation, and the door gaskets for damage and if they are properly sealed. Secure any loose parts.

Panels

Inspect the panels for damage. If the panels show signs of excessive pressure change, they will appear to bulge inward or outward. Refer to *Troubleshooting on page 78* regarding excessive static pressure. If the panel needs to be replaced, use the instructions later in this section.

Hoods and Louvers

Inspect the air hoods and louvers for damage and debris. Remove debris as needed.

Bird Screens

Bird screens are an integral part of hoods and louvers. Inspect the bird screens for damage and debris. Remove the debris as needed.

Optional Moisture Eliminators

Inspect the optional mist eliminators in the air hoods for damage, dirt and debris. Remove the mist eliminators for cleaning as shown later in this section.

Outdoor Air Hood

Clean or replace the outdoor air hood:

1. Remove the clip(s) from the leading edge of the hood as shown in *Figure 41 on page 54*.
2. Remove mist eliminator or cleanable filter.
3. Clean with eco-friendly solution.
4. Install the new mist eliminator or cleanable filter.
5. Reinstall the clips on the leading edge of the hood.

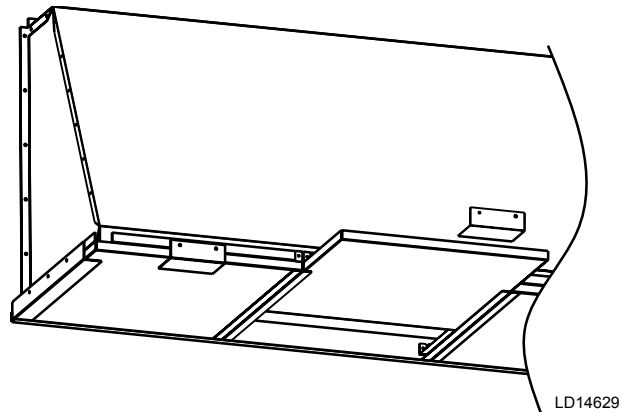

FIGURE 41 - REMOVE MIST ELIMINATOR

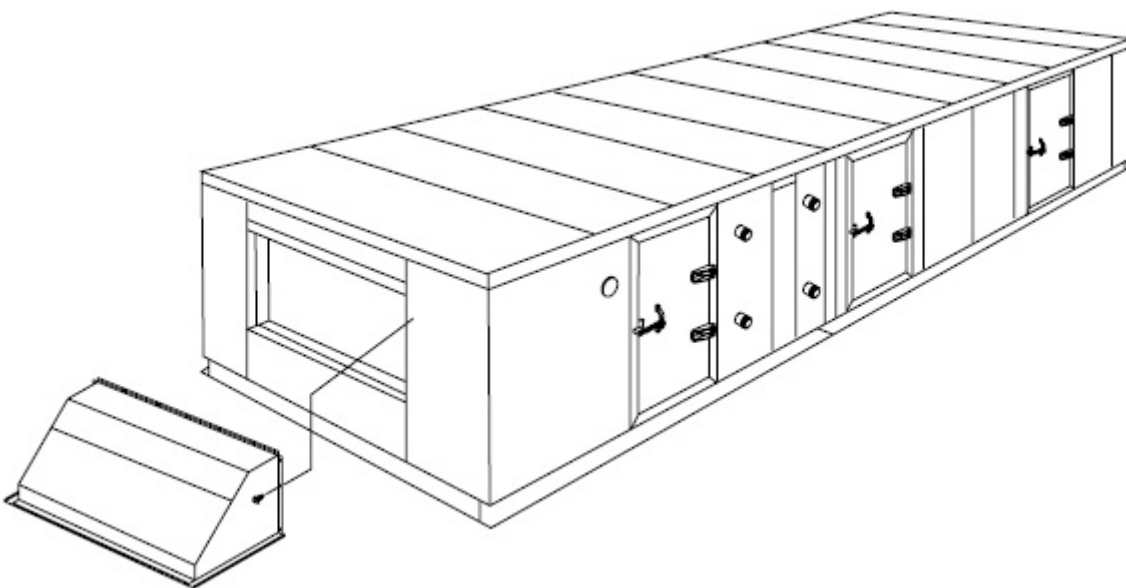
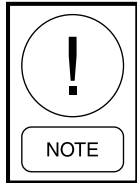

FIGURE 42 - WEATHER HOOD INSTALLATION

FAN SEGMENT (SUPPLY, RETURN OR EXHAUST)

Removing the Fan

If necessary, remove the fans for cleaning. Clean the fan with detergent or solvent that is environmentally safe. If water pressure is used, do not direct the water stream onto the bearing seals.



Forward curved fan wheels are more susceptible to dirt accumulation than other wheels. Dirt and debris on fan wheels and shafts may adversely affect the balance of the fan assembly.

Refer to the information later in this section to replace the fan and fan assembly components.

Checking the Fan

Check the following fan parts for damage, wear, loose parts, and debris:

1. Fan housing, wheel, shaft, frame and bearings
2. Fan base, vibration isolators and optional thrust restraints
3. Flex connector. Make sure the fan assembly does not rub the flex material.
4. Drive kit, which consists of belts, sheaves and sheave bushings. Check for belt tension.

On Solution XT AHUs, the actual data required by design of each fan assembly is listed on the tag affixed to the fan housing near the belts, as shown in *Figure 43* on page 55.



LD16565

FIGURE 43 - TYPICAL DRIVE KIT DATA TAG

OPERATING ADJUSTABLE MOTOR BASE

Standard

5. Secure the nut with a wrench placed through the service hole and loosen the bolt. Do this to all four hold down bolt assemblies, as shown in *Figure 44* on page 55.
6. Make sure the drive bolt assembly threads are lightly lubricated.
7. Turn both drive bolt assemblies in the same direction to move motor for belt installation and tensioning.
8. Turn drive bolt assemblies independently to move motor for sheave/belt alignment.
9. Tighten all four holddown bolt assemblies.

For belt tensioning instruction, refer to *Belt Replacement Tensioning and Sheave Alignment for Top Mount* on page 58.

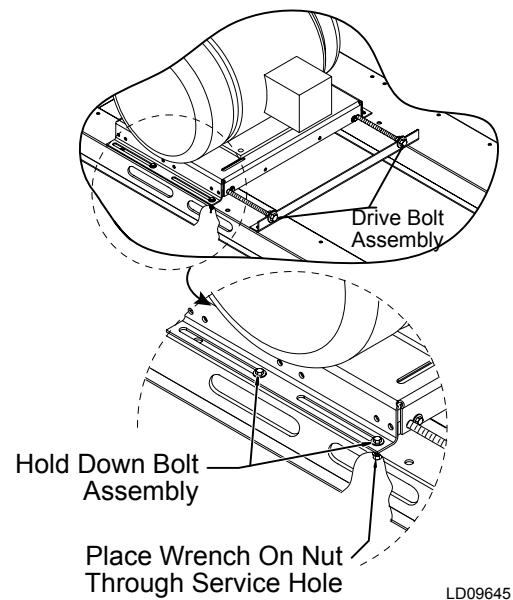
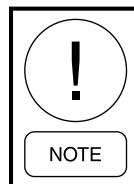
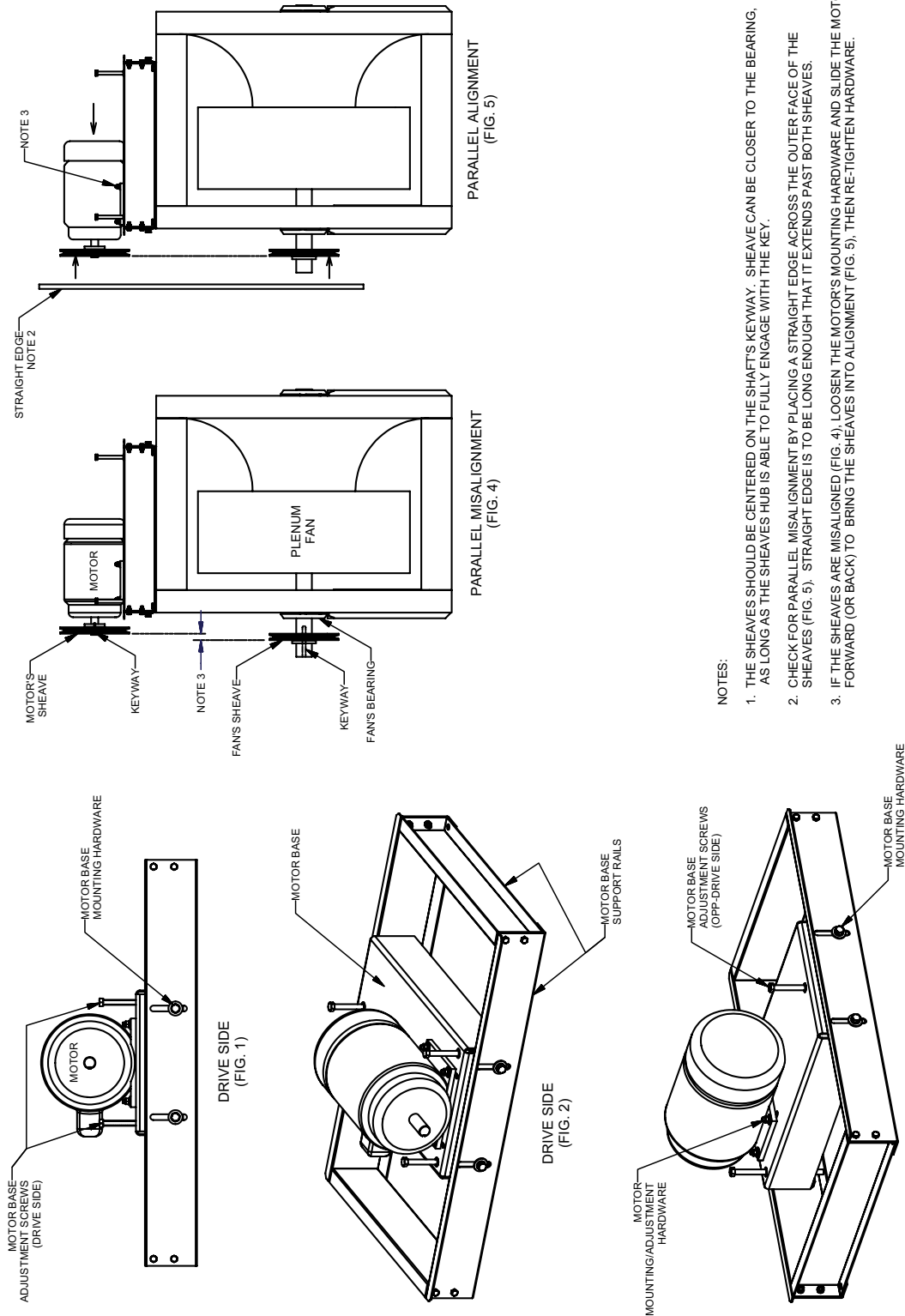

FIGURE 44 - SOLUTION XT ADJUSTABLE MOTOR BASE



Procure replacement drive components locally. A drive label, affixed to the supply fan, lists the drive specifications. However, due to possible changes in the field, replacement parts must be verified against installed parts since the installed parts may not match the label.



NOTES:

1. THE SHEAVES SHOULD BE CENTERED ON THE SHAFT'S KEYWAY. SHEAVE CAN BE CLOSER TO THE BEARING, AS LONG AS THE SHEAVES HUB IS ABLE TO FULLY ENGAGE WITH THE KEY.
2. CHECK FOR PARALLEL MISALIGNMENT BY PLACING A STRAIGHT EDGE ACROSS THE OUTER FACE OF THE SHEAVES (FIG. 5). STRAIGHT EDGE IS TO BE LONG ENOUGH THAT IT EXTENDS PAST BOTH SHEAVES.
3. IF THE SHEAVES ARE MISALIGNED (FIG. 4), LOOSEN THE MOTOR'S MOUNTING HARDWARE AND SLIDE THE MOTOR FORWARD (OR BACK) TO BRING THE SHEAVES INTO ALIGNMENT (FIG. 5). THEN RE-TIGHTEN HARDWARE.

LD16606

FIGURE 45 - SOLUTION XT ADJUSTABLE MOTOR BASE (TOP MOUNT)

Checking Belt Tension

Check the belt tension. It is normal for belts to loosen after start-up or replacement. The new belt will *run in* or *take a set* by seating slightly deeper into the grooves of the sheaves. Recheck tension after one day, and again after three days.

1. Measure the belt span as shown in *Figure 46* on page 57.

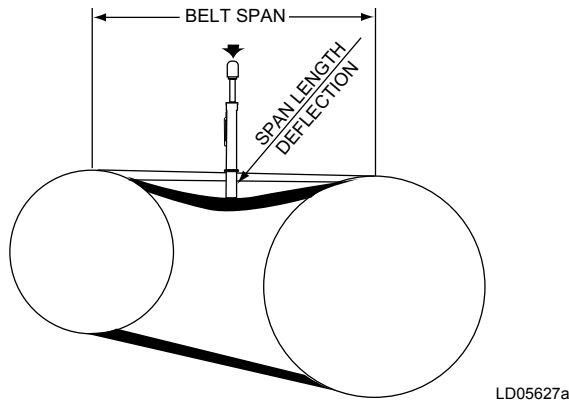

LD05627a

FIGURE 46 - BELT TENSIONING

2. Position bottom of the large O-ring on the span scale at the measured belt span as shown in *Figure 47* on page 57.

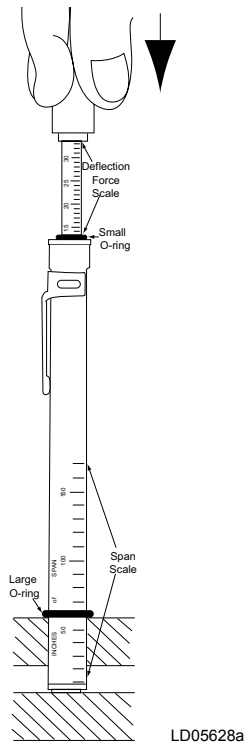

LD05628a

FIGURE 47 - BELT TENSIONING GAUGE

3. Set the small O-ring on the deflection force scale to zero.
4. Place the tension gauge squarely on one belt at the center of the belt span. Apply a force on the plunger and perpendicular to the belt span until the bottom of the large O-ring is even with the top of the next belt or with the bottom of a straight edge laid across the sheaves.
5. Remove the tension gauge and read the force applied from the bottom of the small O-ring on the deflection force scale.
6. Compare the force you have applied with the value given on the drive kit data tag as shown in *Figure 43* on page 55.

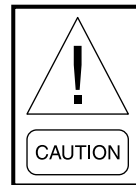

Never use excessive tension because this could result in damaging the bearing, motor pulleys or motor base. Refer to the drive label on the fan housing for specific details on tension. Squealing belts during starting is caused by slipping belts that are not tensioned properly.

ALIGNING SHEAVES

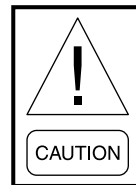

An incorrectly aligned sheave can substantially shorten belt life or overload blower and motor bearings, shortening their life expectancy. A belt tensioned too tightly can overload the motor electrically, causing nuisance tripping of the motor overloads and/or motor failure and/or shaft failure.

Sheave alignment and parallelism of shafts is very important. Proper alignment helps equalize the load across the entire belt width, thereby reducing wear and extending belt life. *Figure 48* on page 58 shows how to align a synchronous drive properly using a straight-edge or shows how to use a piece of string as shown in *Figure 49* on page 58.

After aligning the sheaves, check the rigidity of the supporting framework. Shafts should be well supported to prevent distortion and a resulting change in the center distance under load. Do not use spring-loaded or weighted idlers.

Using a Straightedge

Place a straightedge against the outer edge of the sheaves. *Figure 48 on page 58* shows the four points where the straight edge should touch the sheaves. The straight edge should cross the sheaves at the widest possible part of the sheave.

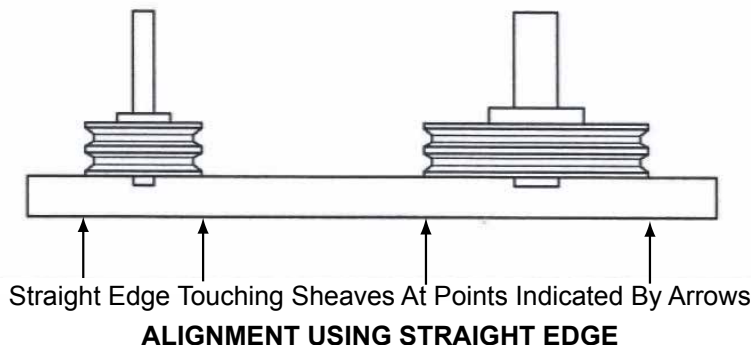

LD09646

FIGURE 48 - ALIGNMENT USING STRAIGHT EDGE

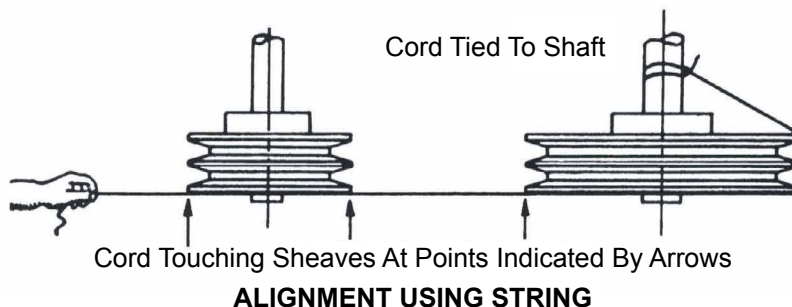

LD09646a

FIGURE 49 - ALIGNMENT USING STRING

BELT REPLACEMENT TENSIONING AND SHEAVE ALIGNMENT FOR TOP MOUNT

Use the following instructions to align the sheaves on the motor base:

1. To remove the old belt, loosen the mounting hardware on the drive side of the motor base. The drive side has two adjusting screws. Do not increase the left side more than 1/2 in before increasing the right side.
2. Remove the tension from the belt on the lower drive side, using the adjustment screws as shown in *Figure 50 on page 59*.
3. After the tension is removed from the belt, loosen the mounting hardware on the opposite drive side of the base.
4. Continue to lower both ends of the base until the belts can be removed as shown in *Figure 51 on page 59*.

5. After the sheaves are checked for parallel alignment as shown in Sheet 1, place the belts on the sheaves.
6. To take the slack out of the belt(s), start raising the base in 1/2 in. increments, using the adjustment screws on both ends.
7. As the belts start to tighten, check for parallel misalignment by placing a straight edge across the outer face of the sheaves as shown in *Figure 52 on page 59*. The straight edge should be long enough to extend past both sheaves.

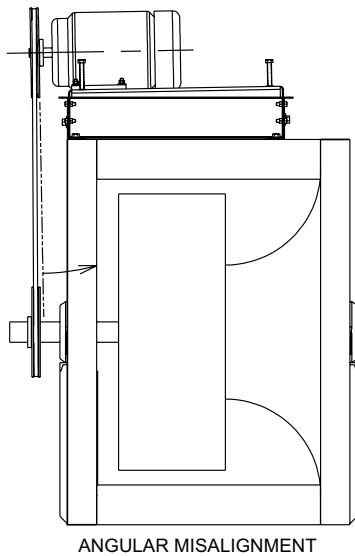

LD165676

FIGURE 50 - SHEAVE ANGULAR MISALIGNMENT

8. If the sheaves are misaligned as shown in *Figure 50 on page 59*, raise the opposite drive side.

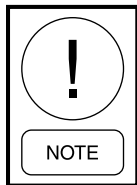

As the belt tension increases, the opposite drive side of the belt will rise. Make sure the mounting hardware on the opposite drive side is secure.

9. Continue to tighten the belt(s), using the drive side the adjusting screws.
10. If the sheaves are still misaligned as shown in *Figure 51 on page 59*, make sure the belt tension is correct, then secure the mounting hardware on the drive side.
11. If the sheaves are still misaligned as shown in *Figure 51 on page 59*, make sure the belt tension is correct, then lower the drive side of the base to remove the belt tension.

12. Loosen the mounting hardware on the opposite drive side, and raise or lower the base accordingly, and repeat Steps 6–10.
13. Mark the position of the base's opposite drive side mounting hardware before lowering the base, which may help determine where to secure the hardware the next time the belt is replaced.
14. Reinstall the belt.

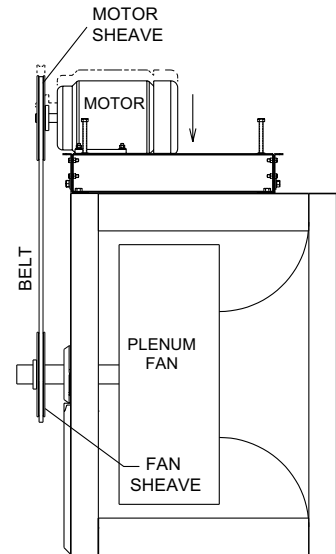

LD165673

FIGURE 51 - MOTOR BASE LOWERED

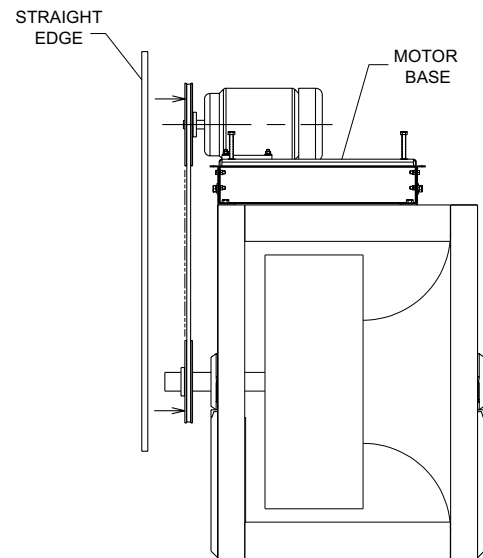

LD165677

FIGURE 52 - SHEAVE ANGULAR ALIGNMENT

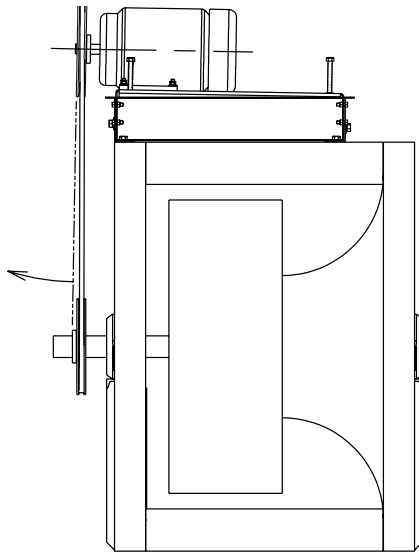

LD165675

FIGURE 53 - SHEAVE ANGULAR MISALIGNMENT**LUBRICATION**

Verify the type of bearings before lubricating them as shown below:

- Sealed (not to be relubricated in the field) as shown in *Figure 54 on page 60*.
- Standard Pillow Block as shown in *Figure 55 on page 60*.
- Split Pillow Block as shown in *Figure 57 on page 61*.

1. Seal (4)
2. Housing Cap
3. Cap Bolts (2)
4. Locating Ring (2)
5. Lock Nut
6. Lock Washer
7. Tapered Sleeve
8. Bearing
9. Housing Base

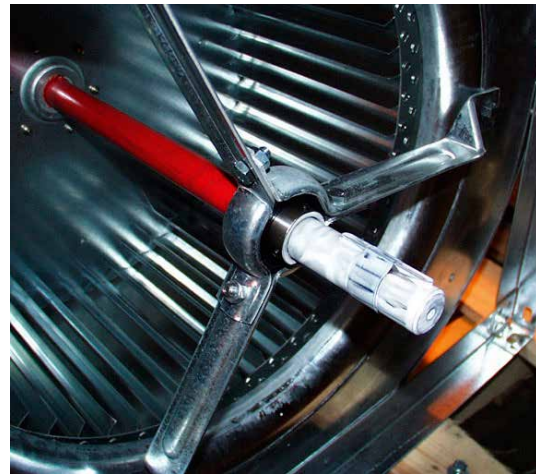

LD16578

FIGURE 54 - SEALED BEARING

LD16579

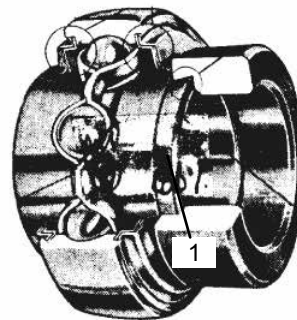
FIGURE 55 - BEARING WITH SET SCREW TYPE LOCKING DEVICE

LD06357

FIGURE 56 - BEARING WITH ECCENTRIC CAM

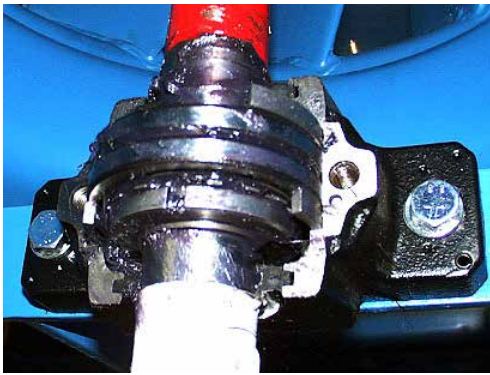

LD09648

- | | |
|----------------------|-------------------|
| 1. Seal (4) | 6. Lock Washer |
| 2. Housing Cap | 7. Tapered Sleeve |
| 3. Cap Bolts (2) | 8. Bearing |
| 4. Locating Ring (2) | 9. Housing Base |
| 5. Lock Nut | |

FIGURE 57 - SPLIT BEARING (ASSEMBLED)

Fan Bearing Lubrication

If the fans will be down for four weeks or more, properly apply correct grease and rotate monthly to prevent moisture from damaging bearings.

Fan bearings on the AHUs are equipped with standard lubrication fittings. AHUs under 42 in. tall will have either extended lube lines, enabling lubrication of both fan bearings from one side of fan as shown in *Figure 58 on page 61* or optional external lube lines. For AHUs 42 in. tall and above, extended lube lines and external lube lines are optional. Some fans will have permanently lubricated bearings.



LD09649

FIGURE 58 - OPTIONAL LUBRICATION LINES

For specific fan bearing lubrication, check the instruction packet attached to the fan housing. Some forward curved fans are permanently lubricated.

For best results, relubricate the standard pillow block bearings while in operation if it safe to do so. Add grease slowly with the shaft rotating until a slight bead forms at the seals.

If necessary to relubricate while the bearing is stationary, refer to the manufacturer’s data for maximum grease capacity for the size bearing.

Relubrication is generally accompanied by a temporary rise in operating temperature. Excess grease will be purged at the seals. Wipe away purged grease after several hours of operation.

Checking Condition of Extended Lubrication Lines

Check the lubrication lines, as shown in *Figure 58 on page 61*, for:

- Cracks and brittleness. Replace as needed.
- Fittings are tight and lube lines tight on fittings.
- Air bubbles in grease. Disconnect and purge as necessary.

Recommended Lubricant for Bearings

Use a lithium/petroleum based grease conforming to an NLGI Grade II consistency. The lubricant must be free of any chemical impurities such as free acid or free alkali, dust, rust, metal particles, or abrasives. This light viscosity, low torque grease is rust inhibited and water resistant, and has a temperature range of -30°F to +200°F with intermittent highs of +250°F. Lubricate bearings as required by the severity of required duty.

Proper Interval and Quantity

Refer to *Table 12 on page 62* for the proper lubrication intervals for the bearings listed earlier in this section.

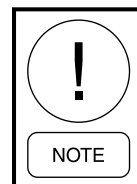

The bearing on the split pillow blocks is 1/3 full when only one side of bearing is completely full of grease.

TABLE 12 - FAN BEARING RE-LUBRICATION INTERVALS FOR BALL BEARING PILLOW BLOCKS

RE-LUBRICATION SCHEDULE (MONTHS - ASSUME 24/7 OPERATION)									
SPEED (RPM)	500	1000	1500	2000	2500	3000	3500	4000	4500
SHAFT DIAMETER (IN)									
1/2 to 1-11/16	6	6	5	3	3	2	2	2	1
1-15/16 to 2-7/16	6	5	4	2	2	1	1	1	1
2-11/16 to 2-15/16	5	4	3	2	1	1	1		
3-7/16 to 3-15/16	4	3	2	1	1	1			

TABLE 13 - FAN BEARING LUBRICATION INTERVALS FOR SPHERICAL ROLLER BEARING SOLID PILLOW BLOCKS

RE-LUBRICATION SCHEDULE (MONTHS - ASSUME 24/7 OPERATION)									
SPEED (RPM)	500	1000	1500	2000	2500	3000	3500	4000	4500
SHAFT DIAMETER (IN)									
1/2 to 1-11/16	6	4	4	2	1	1	1	1	½
1-15/16 to 2-7/16	4	2	1½	1	½	½	½	½	½
2-11/16 to 2-15/16	3	1½	1	½	½	½	½		
3-7/16 to 3-15/16	4	3	2	1	1	1			

TABLE 14 - FAN BEARING LUBRICATION INTERVALS FOR SPHERICAL ROLLER BEARING SPLIT PILLOW BLOCKS

RE-LUBRICATION SCHEDULE (MONTHS - ASSUME 24/7 OPERATION)									
SPEED (RPM)	500	750	1000	1500	2000	2500	3000	3500	4000
SHAFT DIAMETER (IN)									
1/2 to 1-11/16	6	4½	4	4	3½	2½	2½	1	1
1-15/16 to 2-7/16	4½	4	3½	2½	1½	1	½		
2-11/16 to 2-15/16	4	4	2½	1	½				
3-7/16 to 3-15/16	4	2½	1½	1					

TABLE 15 - FAN BEARING LUBRICATION INTERVALS FOR DODGE ISN BEARINGS

SHAFT SIZE (INCHES)	RPM								
	250	500	750	1000	1250	1500	2000	2500	>3000
1-1/8 to 2	4	3	2	2	1	0.5	0.25	0.25	0.25
2-3/16 to 2-1/4	3.5	2.5	1.5	1	0.5	0.5	0.25	0.25	0.25
2-3/8 to 3	3	2	1.5	1	0.5	0.25	0.25	0.25	0.25
3-3/16 to 3-1/2	2.5	1.5	1	0.5	0.25	0.25	0.25	0.25	
3-11/16 to 4-1/2	2	1.5	1	0.5	0.25	0.25	0.25		
4-15/16 to 5-1/2	1.5	1	0.5	0.25	0.25	0.25			
5-15/16 to 6	1	0.5	0.5	0.25	0.25	0.25			
6-7/16 to 7	1	0.5	0.25	0.25	0.25				

LUBRICATING THE FAN SEGMENT AND MOTOR

Keep the motor clean, dry, and properly lubricated at all times. On ODP (Open Drip Proof) type motors as shown in *Figure 59 on page 63*, blow dust and dirt out of the windings periodically, using low pressure air

(50 psig). For Totally Enclosed Fan Cooled (TEFC) motors as shown in *Figure 60 on page 63*, blow dust and dirt out of the cooling fan as conditions indicate.



LD09635

FIGURE 59 - OPEN DRIP PROOF (ODP) MOTOR



LD09639

FIGURE 60 - TOTALLY ENCLOSED FAN COOLED (TEFC) MOTOR

Checking Condition of Mounting Hardware, Adjustable Motor Base and Motor

Hardware and Motor Base - Check for loose parts and damage. If the parts are damaged, replace the parts.

Motor - Check the motor for leaky bearing seals, damage and dirt, dust, and debris in the motor housing.

Checking Electrical Connections

Check the following:

1. Electrical terminations.
2. Conduit fittings and clamps for damage or looseness.
3. Operating amperage, and compare the number to the number listed on the AHU nameplate.

Keep Motor Bearing Lubricated

Bearing grease will lose its lubricating ability over time because the lubricating ability depends primarily on the type of grease, size of the bearing, speed at which the bearing operates, and the severity of the operating conditions. Good results can be obtained if the following recommendations are used in this maintenance program:

1. Use a high-grade ball or roller bearing grease such as Polyrex EM (Exxon Mobile) for all "T" frame motors.
2. Maximum operating temperature for standard motors is 166°F/75°C.
3. Recommended lubrication intervals are shown in Table 16 on page 64. Refer to all three tables.
4. Use the following steps to lubricate the motor.

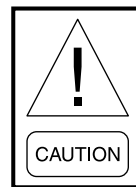

To avoid damage to the motor bearings, keep the grease free of dirt. For an extremely dirty environment, contact your distributor or an authorized service center for additional information.

If the AHU is equipped with a grease relief plug, use the following instructions to replace the grease:

1. Be sure that the grease you are adding to the motor is compatible with the grease already in the motor. Consult a distributor or an authorized service center if grease other than the recommended type is to be used.
2. Clean all grease fittings.
3. Remove the grease relief plug.
4. If motor is stopped, add the recommended amount of grease.
5. If the motor is to be greased while running, add a slightly greater quantity of grease slowly until the new grease appears at the shaft hole in the end plate or relief plug hole.
6. Clean off any grease from the grease fitting.
7. Run motor for 15–30 minutes with the relief plug removed to warm up the grease.
8. Wipe off any grease that was pushed out of the relief plug.
9. Reinstall the grease relief plug.

TABLE 16 - MOTOR BEARING LUBRICATION INTERVALS

NEMA / (IEC) FRAM SIZE	RATED SPEED - RPM (HOURS)					
	10,000	6,000	3,600	1,800	1,200	900
UP TO 210 INCL. (132)	**	2,700	5,500	12,000	18,000	22,000
OVER 210 TO 280 INCL. (180)			3,600	9,500	15,000	18,000
OVER 280 TO 360 INCL. (180)			*2,200	7,400.	12,000	15,000
OVER 360 TO 5800 INCL. (180)			*2,200	3,500	74,00	10,500

* Lubrication intervals are for ball bearings. For roller bearings, divide the listed lubrication interval by 2. Relubrication interval for 6205 bearing is 1550 hrs, and for 6806 bearing is 720 hrs. (Using grease lubrication)

** For 6205 and 6806 bearings. For 6807 bearings, consult oil mist lubrication (MN410).

TABLE 17 - MOTOR BEARING SERVICE CONDITIONS

SEVERITY OF SERVICE	AMBIENT TEMPERATURE MAXIMUM	ATMOSPHERIC CONTAMINATION	TYPE OF BEARING
STANDARD	40°C	CLEAN, LITTLE CORROSION	DEEP GROOVE BALL BEARING
SEVERE	50°C	MODERATE DIRT, CORROSION	BALL THRUST, ROLLER
EXTREME	>50°C* or CLASS H INSULATION	SEVERE DIRT, ABRASIVE DUST	ALL BEARINGS
LOW TEMPERATURE	<-30°C**	CORROSION	

* Special high temperature grease is recommended. Note that high temperature grease may not mix with other grease types. Thoroughly clean bearing and cavity before adding grease.

**Special low temperature grease is recommended.

TABLE 18 - MOTOR BEARING LUBRICATION INTERVAL MULTIPLIER

SEVERITY OF SERVICE	MULTIPLIER
STANDARD	1.0
SEVERE	0.5
EXTREME	0.1
LOW TEMPERATURE	1.0

UVC EMITTER LAMPS

If purchased, the contractor is responsible for installing the UV lamps, and connecting a 120 volt power supply as shown in *Figure 61 on page 65*. The Johnson Controls factory provides the following pre-wired parts.

- Internal wiring with a magnetic door safety switch
- A lockable disconnect switch with a *Press to Test* pilot light
- A latching circuit that has to be manually re-energized on the AHU's exterior after a door has been opened and closed.



Use clean cotton rags, clean jersey or latex gloves to handle the lamps. DO NOT touch UV lamps with bare hands or leather gloves because the oil will damage the lamps.

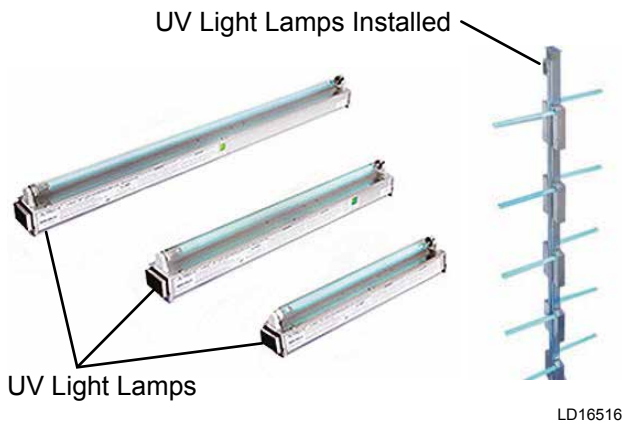

FIGURE 61 - UV LAMPS

Three Types of Lamps

Three different types of UV lamps are used in AHUs: V-Mod, V-Ray, and V-Max Grid.

V-Mod Lamps - Install the two-pronged lamps into the slotted fixtures as shown in *Figure 62 on page 65*, then rotate the lamp 90°.



FIGURE 62 - INSTALLING V-MOD LAMP

V-Ray and V-Max Grid Lamps - Fit the four-pronged lamp into the clamp mounted on the UV segment where a pigtail is installed. Insert the prongs into the pigtail plug.



FIGURE 63 - INSTALLING V-RAY AND V-MAX GRID LAMPS

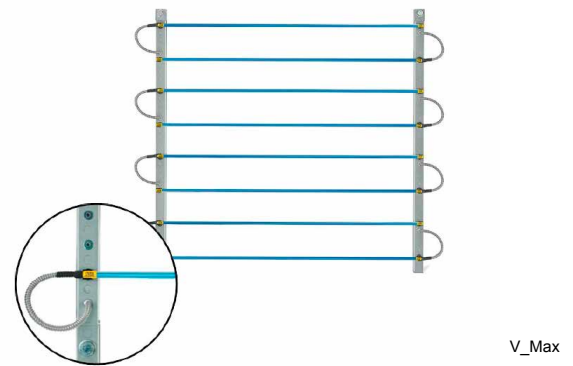
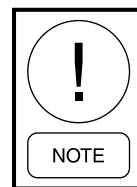

FIGURE 64 - V-MAX GRID LAMPS

MAINTAINING AND REPLACING FILTER SEGMENTS



A list of filter part numbers, sizes and quantities are shown on a label located on each filter segment of each AHU.

Every month, check the cleanliness of the filters, and if necessary, replace them. Filters should be replaced when the pressure drop, measured by a manometer, reaches the prescribed limits for the installation.

Filter Types

Flat, angle, rigid, bag, HEPA and charcoal are the typical filter types as shown in *Figure 65 on page 65*. If your AHU has HEPA filters, the filter frames, bulkheads and segment panels are factory sealed, and must remain sealed for NO air bypass.

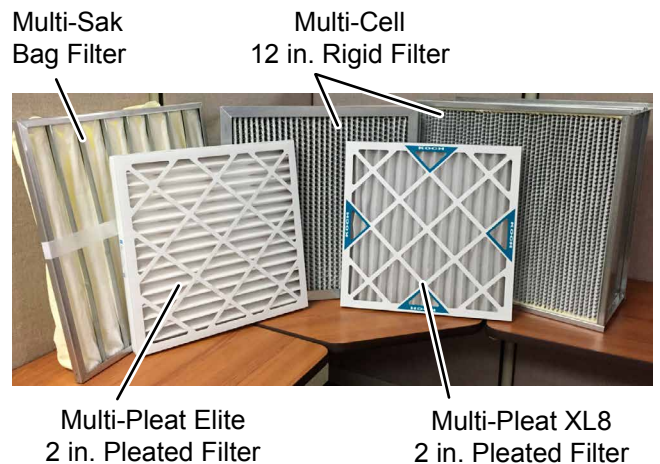

FIGURE 65 - TYPICAL FILTER TYPES

Replacing the Filters

1. Check filter sizes and quantities. Refer to the filter label located on each filter segment.
2. Remove filter frame end cover as shown in *Figure 66 on page 66* and *Figure 67 on page 66*.
3. Remove old filters, if present.
4. Make sure gaskets at both ends of the side load filter tracks are in place. The gaskets are normally found on inside of filter frame end covers.
5. Slide the correct size new filters into tracks.
6. On bag filters (in FF segments), leave banding in place until filters are installed; then remove. Install the bag filters so that the pocket dividers are vertical if the filters are over 12 in. high.
7. Airflow arrows must point downstream (in direction of the airflow).
8. Install all pleated filters with pleats positioned vertically.
9. Reinstall the filter frame end cover.

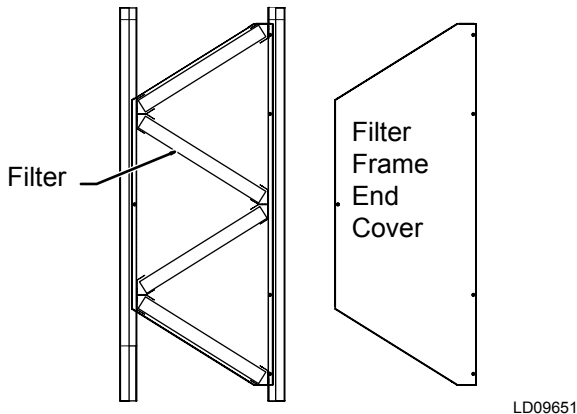

FIGURE 66 - INSTALLING ANGLE FILTERS

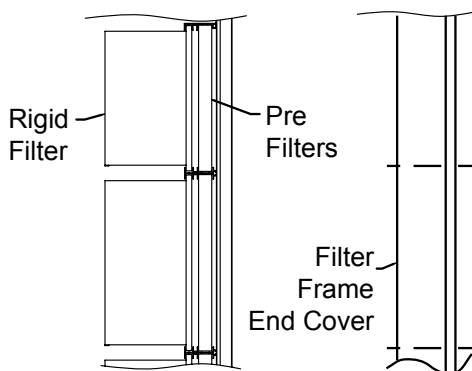
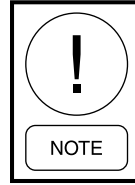

FIGURE 67 - INSTALLING SIDE LOAD FILTERS

ECONOMIZER SEGMENT (DAMPERS)



Prior to occupancy, test ventilation system to ensure that outdoor air dampers operate properly in accordance with the system design.

Cleaning Procedure

Cleaning of dampers should be performed before operation is hindered in any way. Maintenance personnel must determine when cleaning is necessary based on observation and operation.



Do not use lubricants. Johnson Controls suggests cleaning with contact cleaner or 50/50 H₂O/alcohol solution. Consult proper building personnel to ensure above solution will not harm personnel or equipment.

Hardware Check

Make sure all linkage parts, actuators and, mounting brackets are secure.

COIL SEGMENT CLEANING

Tools, Equipment and Materials

- Pressure washer that does not exceed 2000 psi. Sprayer (utility garden, etc.) applicator
- Plastic sheeting and duct tape
- Screening
- Coil cleaner (safe, commercial, disinfecting)
- Garden hose and spray nozzle
- Pail and rags
- Trash bags
- Power cords
- Four-inch paint brush

Cleaning Procedure

1. Clean dehumidification coils annually or when air pressure drop exceeds 125% of design.
2. Cover electrical components such as fan motors, damper motors, compressors, thermostats, etc. with plastic. Care should be taken on interior coil cleaning. Remove filters; cover fan bearings and any insulation to keep these items free of water damage. Condensate drain piping should be screened to allow coil-cleaning water to flow freely. Screening keeps traps and drain lines from clogging with debris washed from the coils.
3. Prior to any application of wet cleaning materials, use a wide soft bristle paint brush to dust off any heavy dust, leaves, bugs or other foreign matter that may be on the coil fin surface.
4. Safety glasses should be worn when cleaning coils.
5. When possible, remove dirt lodged in the depth of the coil by using clean oil-free air under pressure. Caution should be taken not to use extreme high-pressure air as this may cause fin surface damage. Direct the air straight at the openings between the fins and never at an angle, which may bend the fins against one another. Always apply the air from the air leaving side of the coil.
6. On heavily soiled coils, use a safe commercial grade coil cleaner.
7. Follow the safety and mixing instructions as noted on or with the cleaning agent.
8. Spray the cleaning agent on both sides of the coil to be cleaned. Allow the cleaning agent to remain in contact with the dirty surface for about 5 minutes or as recommended by the agent instructions. Then flush the coil with clean water from a hose (with spray nozzle or from pressure washer). Flush from the air leaving side of the coil. Caution should be taken, as extreme water pressure may result in fin surface damage. Direct the water straight at the openings between the fins and never at an angle, which may bend the fins against one another. This process will wash away surface dirt on the air entering side of the coil, and prevent it from loading within the depth of the coil.

9. Most cleaners are concentrated detergents and can be diluted with up to 10 parts water. Dilute as per cleaning agent instructions and coil condition. Re-spray both sides of the coil with cleaner. Allow to stand five minutes and flush as described previously. Finish flushing from both sides of the coil.
10. Follow the cleaning agent instructions. Agent should meet environmental and OSHA standards.
11. Some extreme oil and dirt conditions may require steam cleaning. Most steam equipment can be adjusted to provide a mixture of water and steam at a moderate pressure. Steam alone without the presence of water does not work well with most cleaning agents. Cleaning the coils with steam should be done as described previously.
12. Comb out any bent or flattened areas of the fin surface.
13. Restore the equipment to its operational state.

CONDENSATE DRAIN PAN, TRAP AND LINE CLEANING

Tools, Equipment and Materials

- Toilet bowl brush or similar utility cleaning brush
- Cleaning agent (safe, commercial, disinfecting)
- Rags and trash bags
- Garden hose with spray nozzle or power washer
- Scraper
- Screening
- Wet vacuum

Schedule and Conditions

1. Clean condensate drain pan, trap, drain line and adjacent wetted surfaces at least annually or as often as required to retard growth of microbial substances.
2. **Test Drain Pans** - To minimize conditions of water stagnation that may result in microbial growth, field test drain pans under normal operating conditions to ensure proper drainage.
3. **Exception** - Field testing drain pans is not required if units with factory-installed drain pans have been certified (attested in writing) by the manufacturer for proper drainage when installed as recommended.

Cleaning Procedure

1. Cover any nearby components such as motors, control devices or wiring.
2. Sweep, gather and remove debris from drain pan, auxiliary pans and splash guards.
3. Scrape loose and remove any clinging substances.
4. Cover drain pan outlet with screening to prevent drain clogging.
5. Prepare cleaning agent per manufacturer's instructions.
6. Apply cleaning agent with spray applicator or brush.
7. Apply cleaner to **ALL** surfaces including: underside of coil, header and return bends if in air stream, coil supports, coil wall or bulkhead, auxiliary drain pans, splash guards, any other surfaces subject to wetting by condensation dripping or carried by normal airflow, drain pan and outlet.
8. Add ample amount of cleaning agent to drain line and trap.
9. Allow cleaner to stand for time required by manufacturer's instructions.
10. Flush with clean water from pressure washer or garden hose with spray nozzle.
11. Apply as much water under pressure as possible to drain outlet to clean trap and drain line.
12. Remove water from any puddle areas with wet vacuum.
13. Wipe down if necessary to remove any stubborn material.
14. Restore equipment to operational state.

Coil Freeze Protection

All chilled water, hot water and steam coils can be damaged during freezing weather. Take the following re-cautionary measures to prevent freezing:

- For year round operation, glycol and other anti-freeze solution must be circulated.
- During winter operation and shutdowns such as power failure, night shutdown and weekend shutdown, the controls must be installed so the valves will go to the full heat position, and all fresh air dampers go to the full closed position. The wa-

ter circulation pumps must keep circulating water through the coils and/or auxiliary heat must be maintained inside the AHU cabinet.

- Draining each coil and related piping such as traps and making sure that all low areas also drain.
- After draining, flush the coils with an antifreeze solution such as propylene glycol. A solution of 50% glycol and 50% water will protect from freezing to approximately 35°F below zero at sea level. Use adequate mixture for the geographic area of the installation.
- Winterizing Drain Traps
- During the winter months when the cooling system is turned off, and the unit is exposed to freezing conditions, an anti-freeze solution, which is environmentally friendly and safe for the roof can be poured in the condensate drain trap to prevent freezing and possible damage. The condensate drain trap may also be removed as well as heat traced and insulated.

ENERGY RECOVERY WHEEL

This AHU will be equipped with an energy recovery wheel from one of the following vendors. Refer to the correct instructions to maintain and clean this AHU.

- Airxchange®
- NovelAire® Technologies
- Thermowheel®
- Innergy tech®

AIRXCHANGE®

Tools and Materials

- Brushes
- Loctite
- Screwdriver
- Acti-Klean or alkaline detergent

Periodic cleaning of the energy recovery wheel will be a function of the operating schedule, climate, and contaminates in the indoor air being exhausted and outdoor air being supplied to the building.

Cleaning the Wheel

- To clean, gain access to the energy recovery wheel and remove the segments as shown in the service manual.
- Brush or vacuum foreign material from the face off the wheel.
- Wash the segments in a 5% solution of non-acid based coil cleaner (*see material list*) or alkaline detergent and warm water.
- Allow segments to soak in solution until grease and tar deposits are loosened. An overnight soak may be required to adequately loosen heavy deposits of tar and oil based contaminants. Before removing from solution, rapidly run finger across surface of segment to separate polymer strips for better cleaning action. Rinse dirty solution from segment with clean water and allow excess water to drain prior to remounting segments in the wheel in the service manual as shown in *Figure 68 on page 69*. A small amount of water remaining in the wheel will be dried out by the airflow.

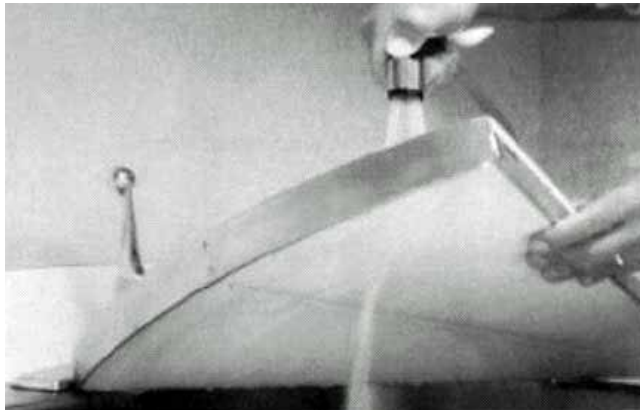

LD09659

FIGURE 68 - RINSE SEGMENTS

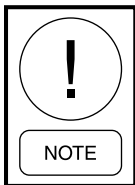

Some staining of the desiccant may remain and is not harmful to performance.



Do not use acid based cleaners, aromatic solvents, steam or temperatures in excess of 170°F: damage to wheel may occur!

Adjusting Air Seals

Four adjustable diameter seals are provided on each cassette to minimize transfer of air between the counter flowing airstreams.

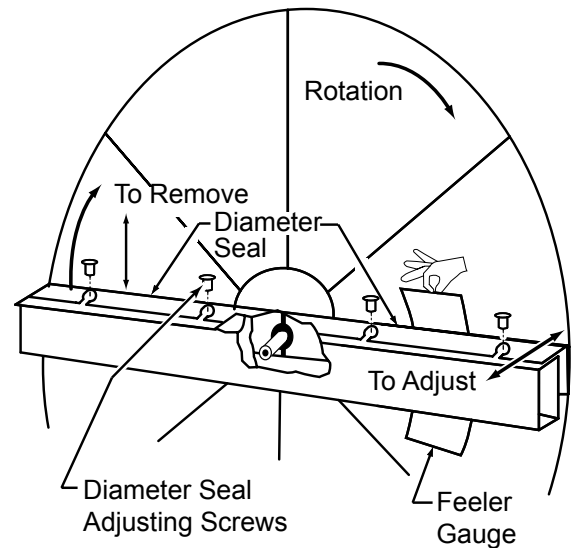

LD09644

FIGURE 69 - DIAMETER SEAL ADJUSTMENT

- To adjust diameter seals, loosen diameter seal adjusting screws and move diameter seal away from wheel surface.
- Rotate wheel clockwise until two opposing spokes are hidden behind the bearing support beam as shown in *Figure 70 on page 70*.

Using a folded piece of paper as a feeler gage, position paper between the wheel surface and diameter seals. Adjust seals towards wheel surface until a slight friction on the feeler gage (paper) is detected when gauge is moved along the length of the spoke.

- Retighten adjusting screws and recheck clearance with feeler gauge.

Adjusting Air Seals

The seals are designed to be durable and require no maintenance other than adjustment. But, if the seals become worn or damaged, replace them. Clip the seals to the cassette or post metal.

Inspect Wheel Drive Components

Bearings - Small wheels are equipped with no maintenance inboard bearings, which should require no maintenance during the life of the AHU. Larger wheels come equipped with an external flanged bearing, which should be greased annually with a petroleum-based lubricant.

Drive Motor - The drive motors should require no maintenance. If the motor needs to be replaced, Replacement motors may be purchased from normal motor distributors.

Drive Belts - Wheel belts are multi-link belts with individual links constructed of a high performance polyurethane elastomer, which is reinforced with multiple plies of polyester fabric. This belt provides strong, yet flexible belting. The multi-link feature provides quick, easy servicing or replacement.

How to Measure, Assemble and Install

How to Measure - Pull belt tight around pulleys to check hand tight length, overlapping the last two tabs with two holes in matching links as shown. Count the number of links and remove one link for every 24 of 3L, Z/10, A/4L and B/5L sections, and one link for every 20 of C and D sections. This gives the correct installed belt length and will ensure optimum belt tension when running.



LD17099

FIGURE 71 - HOW TO MEASURE

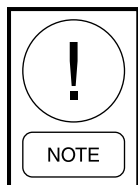

Every tenth link is designated with an arrow (→) (3L, Z/10, A/4L and B/5L only). For multiple belt drives, ensure that each belt has the same number of links.

IMPORTANT - Turn belt **INSIDE OUT** (as shown) to ensure easy assembly and disassembly.

Disassembly

- A. Hold belt upside down. Bend back as far as possible; hold with one hand. Twist one tab 90° parallel with slot.
- B. Pull end of link over tab.
- C. Rotate belt end with tab 90°.
- D. Pull belt end through two links.



LD17100

FIGURE 72 - DISASSEMBLY

Assembly

- A. Hold belt with tabs pointing outward.
- B. Place end tab through two links at once.
- C. Flex belt further and insert second tab through end link by twisting tab with thumb.
- D. Ensure tab returns to position across belt. Reverse belt so tabs run inside.



LD17101

FIGURE 73 - ASSEMBLY

Installation

1. Turn belt with tabs to the inside before installing.
2. Determine direction of drive rotation.
3. Belt must travel with tabs trailing or following the belt direction arrow (→).
4. Fit belt in nearest groove of smaller pulley.
5. Roll belt onto larger pulley, turning the drive slowly. Belt may seem very tight; this is ok; **DO NOT JOG MOTOR**.
6. Check to see all tabs are still in their correct position and are not twisted out of alignment.
7. For multiple belt drives, work belt from groove to groove. On particularly wide drives, it may be easier to install half the belts from the inboard side and half from the outboard.

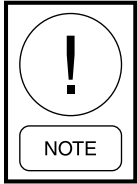

LD17102

FIGURE 74 - INSTALLATION

With drive ratios around 1:1, it may be necessary to add back one link to allow belts to be rolled on. This does not apply if using the Alternative Installation Method.

Alternative Installation Method

1. Set motor to mid-position of adjustment range and mark base clearly.
2. Determine required belt length as in I.
3. Push motor forward to minimum centre distance.
4. Install belts as in IV.
5. Pull motor back to previously marked mid-position.

Retensioning

Like all high performance V-belts, PowerTwist Plus V-Belts require the maintenance of correct drive tension to operate efficiently. Experience indicates that drive tension should be checked after 24 hours running at full load. A retension may be necessary depending on the severity of the drive. Any initial belt stretch is then taken up. Subsequently, belt tension should be checked periodically and adjusted when necessary.

THERMOTECH®

Periodic cleaning of the energy recovery wheel will be a function of the operating schedule, climate, and contaminants in the indoor air being exhausted and outdoor air being supplied to the building.

Cleaning the Wheel

The wheel media does not require any cleaning under normal operating conditions and proper maintenance of the drive systems and main bearings. The key is to make sure the wheel is always turning in order to utilize the counter flow airstreams and the purge sector to keep the media clean. Over the years there might be some accumulation of dirt on the face of the media, but the inside will remain clean.

The best method to clean the wheel is to brush the surface on the air discharge side with the airflow on, or by using a vacuum cleaner. A 2,300 psi pressure washer can be used in situations where the media is severely clogged. Care should be taken to not damage the media face by the full force of the spray. It is recommended that the pressure cleaning method is tested on a small Area Of The Media.

Adjusting Air Seals

The seals are set at the factory and should not require adjustment. If the seals are rubbing on the media face, due to incorrect installation and other factors, adjust the seals.

1. Rotate the wheel one full revolution, and determine where the wheel media face is rubbing on the seal.
2. Working on one seal quadrant at a time, loosen the seal Tek screws as shown in *Figure 75 on page 72*.
3. Move the seal away from the wheel surface until no more rubbing is noticed.

A typical large diameter wheel will have a flatness variation of 1/16 in. from the high to low point of the wheel surface. If the seals are adjusted correctly, the seal gap will vary that much as the wheel turns, but the seal should never touch the wheel surface.



LD16608

FIGURE 75 - LOOSEN SCREWS BEFORE ADJUSTING SEALS

Inspect Wheel Drive Components

Rotor Bearings - The main rotor bearings have been sized for an L-10 life of a minimum of 25 years; operating 24 hours per day, 7 days a week. The main reason that a main bearing would fail is lack of lubrication or the existing grease hardens in the bearing due to evaporation or by penetration of moisture causing corrosion. The bearings are filled with grease at the factory or at the time of start-up to eliminate a future failure.

Add a small amount of grease every six months to maintain fresh grease on the inside of the bearing. Wipe off any excess purged grease to avoid it getting blown onto the wheel surface. All bearings are greased with a Dow Corning Molycote BR2 Plus Grease, which is available through most bearing distributors

Drive System - The motor does not require any maintenance and has permanently lubricated bearings. The speed reducer is grease lubricated as well and does not require any maintenance. Life expectancy is in excess of 10 years.

The drive belt tension does not need any adjustment, due to the gravity based mounting base used. The B-type V-belts are installed with a B-437 belt connector manufactured by FLEXCO. This connector will eventually wear out and need to be replaced. A typical life span is five to 10 years, depending on the environmental condition.

INNERGY TECH®

Cleaning the Wheel

In most applications, it is not necessary to clean the media of the wheel because the wheel rotates. Incoming and outgoing airstreams are constantly blowing debris out of the media during operation. If cleaning is needed, clean the media with a vacuum cleaner or pressurized air. It is not recommended to use any type of solvent or detergent on the wheel because it may cause damage to the media or the material used to build the wheel.

Adjusting Air Seals

The Innergy tech energy recovery wheels are equipped with our AirLoop™ labyrinth seals facing the media, low friction side seals along the depth of the rotor and S-type labyrinth peripheral seals along the outer edge of the rotor as shown on the seal general overview drawing below. While the side seals and peripheral seals are factory adjusted and don't need further adjustment, the AirLoop™ labyrinth seals should be verified prior to start-up and adjusted if needed. See *Figure 76 on page 73*.

As illustrated in *Figure 77 on page 74*, the correct adjustment of our AirLoop™ labyrinth seal is obtained by allowing it to barely touch the media before tightening the screws. If an initial gap can be seen between the seal and media, the seal is installed too far and should be moved closer until it touches the media. On the other hand, if any deformation to the lips can be seen, it means the seal is installed too close and should be moved back until the lips are straight again.

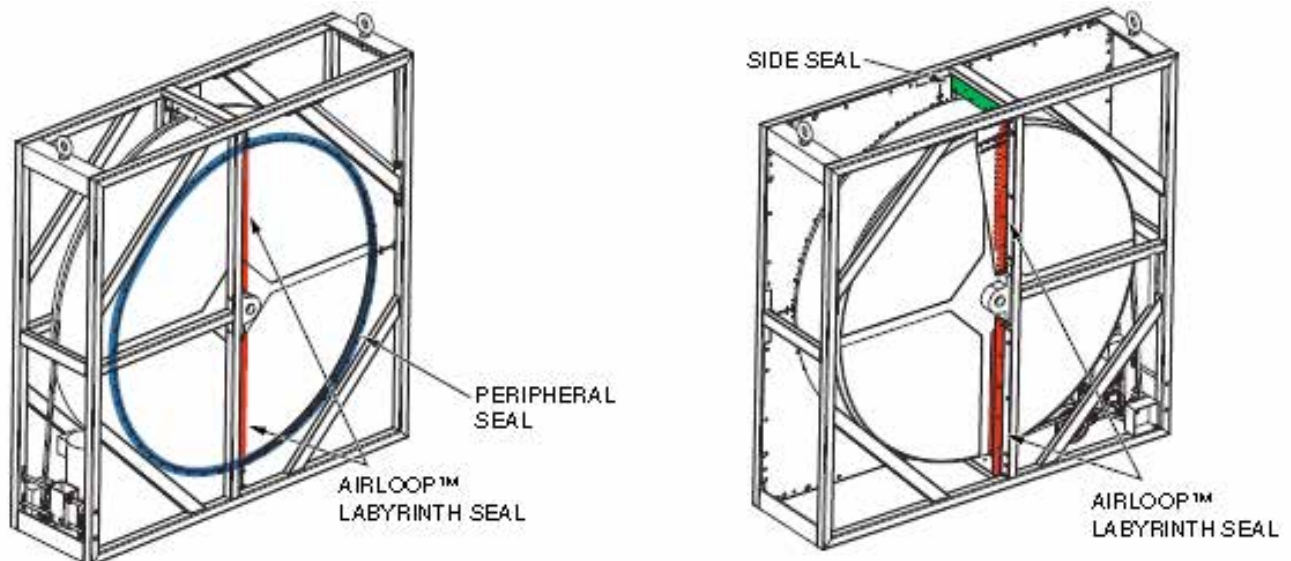

FIGURE 76 - ERW SEAL LOCATIONS

LD17097

It should be noted that the AirLoop™ labyrinth seal is made of a special material which was specifically chosen to make sure it could never damage the media. While the best seal is obtained when the above steps are followed, if installed too close, the media will simply use the seal a little more. As the wheel turns, the seal will automatically adjust itself to the wheel's tolerance (approximately 1/32") for the smallest possible air leakage and become a non-contact seal that will last throughout the wheel life.

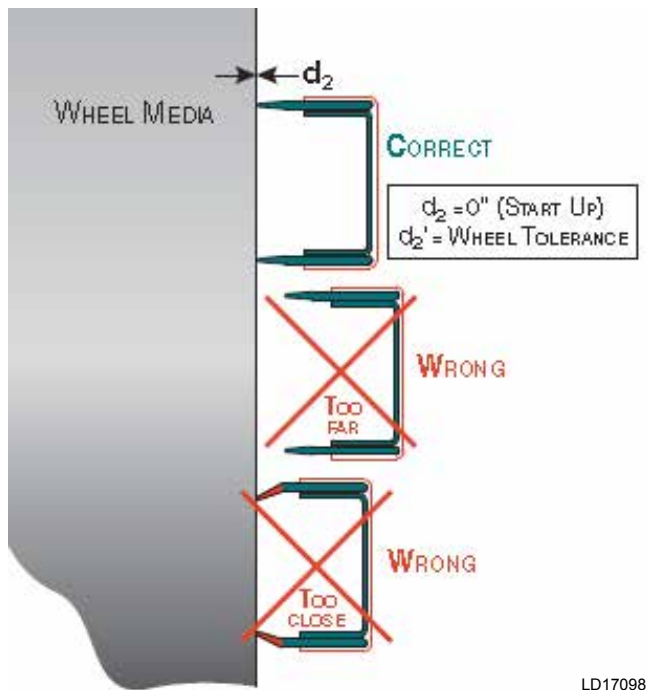

FIGURE 77 - AIRLOOP™ LABYRINTH SEAL ADJUSTMENT

LD17098

Inspect Wheel Drive Components

Bearings - Wheel bearings are greased before shipping, but it is recommended to grease them again before start-up. Proper care and maintenance of the wheel bearings should allow it to last up to 20 years.

Lubrication of bearings and bearing bolts varies depending on the temperature range in which the wheel will be used. For a typical temperature range of -40°-130°F (-40°-54°C) recommended lubrication is every six months. A NLGI grade 2 consistency, mineral oil lithium or lithium complex based grease is recommended to be pumped into the two bearing grease points.

Check the following parts for tightness before start-up and every six months:

- Bearing bolts
- Bearing set screws (two on each side of the wheel). Torque them to 13 ft-lb for wheels up to 78 in. diameter and 24 ft-lb for wheels from 88-120 in. diameter.

Motor Bolts - Check the bolts securing the motor to the base plate periodically for tightness (hand-wrench tight) at start-up, after one month of operation, and annually thereafter.

Drive Belts - The belt is a high performance link belt which allows installation or replacement without using special tools. Innergy tech recommends checking the belt after a month of operation and every three months through a general maintenance check. The inspection should focus on belt wear and correct tension. If improper tension is noticed, simply reduce the length of the belt by removing a few links. If the belt needs replacement, contact Innergy tech for a new belt (Innergy tech will need the serial number and the size of the wheel). The belt is directional; it must be installed with the directional arrows pointing in the direction of the motor rotation.

Belt is installed in six steps:

1. Ask Innergy tech for belt length. The length depends on the wheel diameter.
2. If needed remove links by twisting the link tabs sideways and pulling the surplus out of the belt.
3. Tape one end of the new belt to wheel and make it turn by hand one complete revolution. The wheel should turn freely if belt is removed.
4. Pull the belt tightly around the wheel and reducer sheave.
5. To connect both free ends of the belt, hold belt with tabs pointing outward. Place end tab through both links at once. Flex belt further and insert second tab through end link by twisting tab with thumb. Ensure tab returns to position across belt.
6. Reverse belt so tabs turn to the inside of belt.
7. Pass the belt over the tensioner idler sheave. If there is no tension in the tensioner, reduce the length of the belt.

ECONO-DISK®

Maintenance Instructions

By design the ECONO-DISK® is inherently maintenance free.

The mechanism has an integral mechanical stop to prevent over travel of the disk at both extremes. The disk is supported by a solid type 416 ground stainless steel shaft and two permanently lubricated bronze bearings. The operating linkage is permanently lubricated and requires no more than occasional routine inspection.

P-CONE®

Maintenance of P-Cone®

Basic P-Cone® maintenance involves keeping the eight tiny pressure pickup holes, in the flange and throat of the inlet cone, free from blockage or debris buildup and periodically checking the tubing and fittings attached outside the P-Cone® for wear or damage.

In addition, periodically back-flushing each line gently with compressed air may help to blowout debris in the line and pressure pickup holes. It is helpful to keep the inside surface of the cone clean; especially in a one inch radius immediately around the pressure pick-up holes.

In the unlikely event that the pneumatic tubing on the P-Cone® is damaged, simply remove the damaged section and replace with comparable type of tubing.

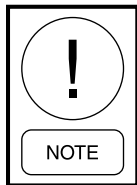

Pressure differential on tubing is less than 1 psig.

In the unlikely event that one of the brass fittings, which is sweated to the P-Cone®, breaks loose from the P-Cone®, then simply remove that fitting and replace it with a straight coupling fitting of similar and common sort. In this event, do not attempt to re-solder the fitting to the P-Cone®.

There are four pickup holes on each piezometer ring. Elimination of one of them will not adversely affect the performance of most P-Cone®.

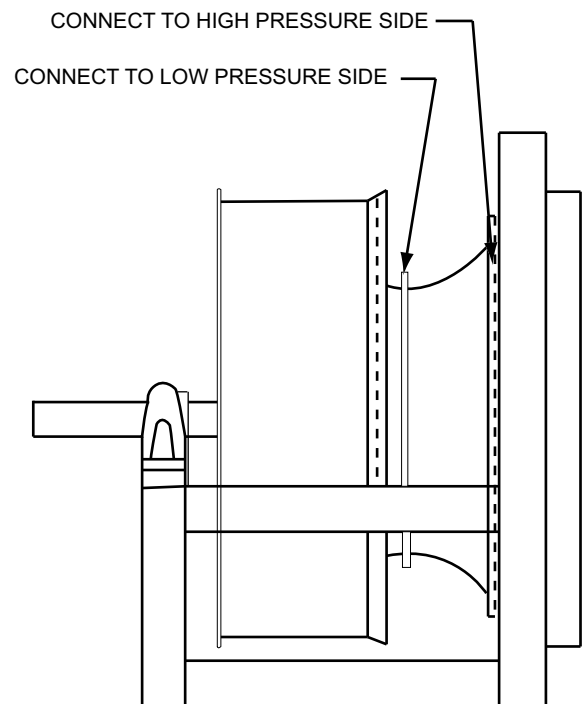

LD010164

FIGURE 78 - PLENUM FAN TAP LOCATION AND CONNECTION ILLUSTRATION

 MAINTENANCE RECOMMENDATIONS FOR YORK AIR HANDLER (Includes suggested IAQ minimums for ASHRAE Std. 62-2010 Compliance)		MONTHLY	QUARTERLY	YEARLY	OTHER
PROCEDURE					
Clean exterior of air handler cabinet.					
Inspect doors, handles, latches and hinges for proper operation.					
Inspect door gaskets for damage and proper seal.					
Inspect panels for damage.					
Inspect air hoods and air louvers for damage and debris.					
Inspect bird screens for damage, dirt and debris.					
Clean fan segment and fan assembly (supply, return, exhaust).					
Check fan housing, wheel, shaft, frame, inlet vanes and bearings for damage, wear, loose parts, dirt and debris.					
Check fan base, vibration isolators and thrust restraints for damage, wear, loose parts, dirt and debris.					
Check flex connector for damage and wear.					
Check the cleanliness of the filters and replace or clean as required.					
Check filter frames (filter tracks) for residual contaminants and clean as necessary.					
Verify filter gauge and/or switch function properly.					
Check drive kit for damage, loose parts, wear, dirt, alignment and belt tension.					
Check belt tension.					
Lubricate fan bearings. (Ball Bearing-Table 4-2, Roller Bearing-Table 4-3, Split Pillow Block-Table 4-4)					
Check condition of extended lubrication lines when present.					
Clean variable inlet vanes.					
Check adjustable fan motor base and mounting hardware for loose parts.					
Check adjustable fan motor base for damage.					
Check fan motor for leaky bearing seals.					
Check fan for motor damage.					
Clean dampers.					
Check for dirt, dust & debris in air vents on fan motor housing.					
Clean dehumidification coils.					
Clean condensate drain pan, trap, drain line and adjacent wetted surfaces.					
Check, clean and calibrate controls.					
Check Energy Recovery Wheel, clean media, adjust seals, replace belt					

1. For operating and maintenance requirements listed above, refer to appropriate service literature, or contact your local Johnson Controls Service Office.
 2. This procedure must be performed at the specified time interval by a Qualified Technician. A record must be maintained should proof of adequate maintenance be required for warranty validation.
 3. More frequent maintenance may be required depending on actual operating conditions.

FIGURE 79 - MAINTENANCE REQUIREMENTS

SECTION 4 - SERVICE AND REPAIR



Rotating parts and electrical shock hazards exist. Lock out and tag out the fan motor(s) and heat power disconnects before servicing. FOLLOW THE LATEST "LOCKOUT TAGOUT" PROCEDURE. Failure to follow proper safety precautions may result in serious injury or death. Refer to general safety guidelines and safety symbols located at the front of this manual.

Always replace RED metal tab on access doors that provide access to moving parts. This mechanical protection from moving parts is required by UL-1995.

Always replace RED metal tab on access doors that provide access to pressurized areas. This mechanical protection is to prevent accidental release of access doors under positive pressure.

Do not weld or use torches on the exterior or interior of the AHU housing. The housing contains polyurethane insulation, which, when under combustion, will produce harmful, toxic gases resulting in personal injury or death.

DO NOT PENETRATE WIREWAYS in any manner. These sheet metal channels, which run along the top panel, contain electrical wires and connections. Electrical shock and/or damage to the AHU may result.

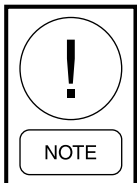

Never use silicone caulk/sealant or caulk/sealant containing silicone in or on any AHU. The only exception is when the AHU is provided with high temperature gas heat venting.

SERVICE TOOLS AND EQUIPMENT

- Complete set of Mechanics Hand Tools
- Observation Mirror
- Fin Comb (straightener)
- Heat Gun
- Straightedge
- Tachometer
- Manometers, capable of 0.01-36 in. combined
- Digital Manometer (replaces Magnehelic Gauge). Cat. #475-1 FM-AV, Series: 475-1 Mark III, with a range: of 0 to 19.99 in. WC from Dwyer Instruments, Inc.
- Pitot Tube
- Duct Hood
- Velometer and Psychrometer
- Combustion Efficiency Analyzer.
- Standard refrigeration gauges/manifold
- Refrigerant reclaiming
- Refrigerant leak detector
- Vacuum pump
- Gas torches (soldering and/or brazing)
- Fire extinguisher
- Electronic Temperature Meter (min. 3 leads)
- Megohm and Phase Meters
- Capacitor Analyzer.
- Clamp-on Ammeter.
- Multi-Meter or Meters, capable of reading the following:
 - One Thousand Volts AC/DC
 - Amperes
 - Ohms.
 - Milli-volts
 - Milli-amps.
 - Microfarad

SERVICE INFORMATION

All necessary tags and decals to aid in service or to indicate caution areas are provided. Electrical wiring diagrams are attached to the control panel access door. Installation, operation, and maintenance manuals are supplied with each AHU.

This AHU offers unlimited unit access with completely removable panels. All of the AHU panels, including the top panels, can be completely removed. Removing the top panels allows the use of overhead cranes and gantries to remove and service the components. Fan and filter segments come equipped with doors.

TROUBLESHOOTING

An HVAC air system includes the AHU and the entire air circuitry through which airflows. Included are the following parts/assemblies:

- Ductwork, Fittings, and Branch Ducts
- Dampers
- Heat Exchangers
- Air Filters and Sound Traps
- Coils
- Elbows and Diffusers
- Grilles, VAVs, and MITs
- Other items through which airflows or which offer obstruction to airflow.

While differences in temperature and humidity may cause air movement, it may be considered very slight compared to the positive circulation required in an air conditioning system. To accomplish this air movement, a fan performs two functions:

- Produce sufficient pressure or head to accelerate the mass of air from a state of rest to the required velocity.
- Produce sufficient pressure to overcome any resistances to the flow of air.

Determining these pressures is important when troubleshooting an air conditioning system. The generally accepted standard instrument for measuring these unit pressures is the pitot tube as shown in *Figure 80* and *Figure 81* on page 78. The pitot tube is used in conjunction with an inclined manometer, magnehelic gauge, or a tube manometer.

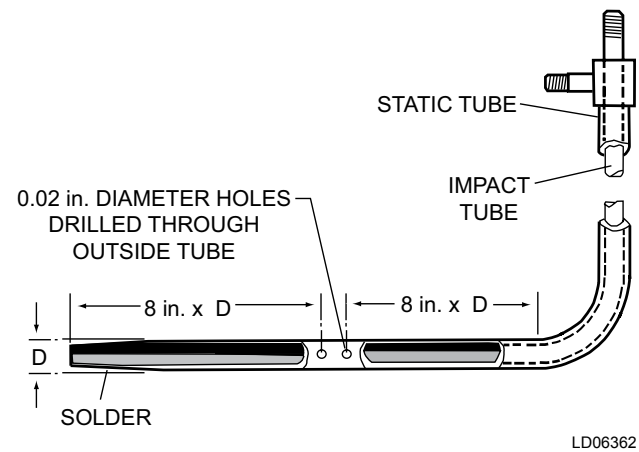

FIGURE 80 - CONSTRUCTION OF PITOT TUBE

When the pitot tube is used in conjunction with these instruments, one is able to read velocity pressure (VP), static pressure (SP), and total pressure (TP) within the system.

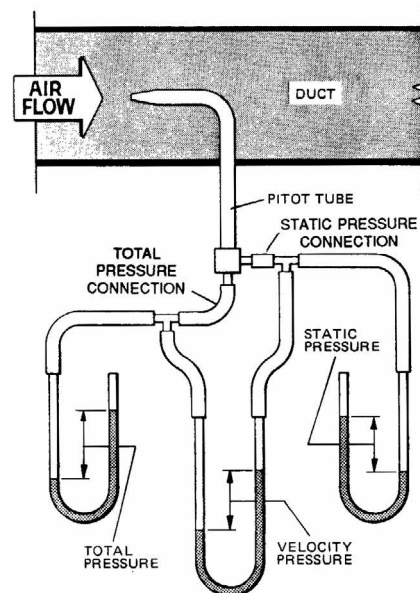

FIGURE 81 - PITOT TUBE

PITOT TUBE

The pitot tube consists of an impact tube within a larger static tube. When the impact tube is pointed directly into the air stream, the small static pressure holes are perpendicular to the air stream and are not affected by air velocity as shown in *Figure 81* on page 78.

To read velocity pressure, the total pressure tap at the end of the pitot tube is connected to one leg of a manometer and the static pressure tap at the other leg of the manometer, as shown in *Figure 82 on page 79*.

INCLINED MANOMETER

This instrument is a simple, fool proof device, which responds directly to the air pressure exerted against it (transmitted from the pitot tube), and reads directly in inches of water. Ranges vary. The technician should have one or more instruments to cover the range of 0-8 inches of water as shown in *Figure 82 on page 79*.

Before using the inclined manometer, ensure the instrument is level, and then adjust the meniscus to the zero mark. The adjustment knob is located at the base of the fluid reservoir.

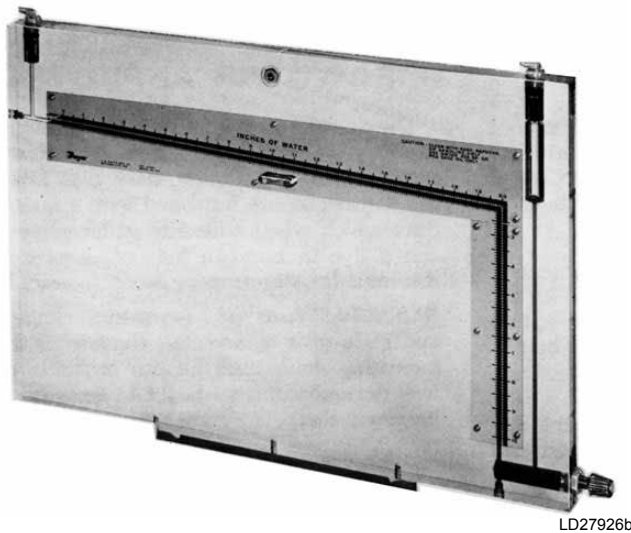

FIGURE 82 - INCLINED MANOMETER

FILTER GAUGE

The filter gauge, a diaphragm-operated gauge, has several advantages over a liquid manometer.

Unless extreme accuracy is required, this instrument may replace the manometer for average air conditioning work, and like the manometer, is available in a variety of ranges. A minehelic gauge is only two in. in diameter and has a limited scale. A magnehelic gauge is four in. in diameter and has a limited scale. Several instruments may be required to cover the normal ranges encountered in average air conditioning jobs as shown in *Figure 83 on page 79*.



LD11693

FIGURE 83 - MINIHELIC FILTER GAUGE



LD19130

FIGURE 84 - MAGNEHELIC FILTER GAUGE

The filter gauge should be factory-installed level. Adjust indicator to zero with no airflow or pressure difference across the sensors. The adjustment screw is located at the bottom behind the plastic cover. When replacing the cover, do not over tighten. The cover could "bottom out," causing the indicator to stick. When the airflow is initiated, the indicator should move to the right. If it moves in the opposite direction, reverse the tubes.

U-TUBE MANOMETER

Pressure is defined as force per unit area. The best way to measure air pressure is to balance a column of liquid of known weight against the air pressure, and measure the height of liquid columns so balanced. The units of measure commonly used are inches of mercury (in. Hg.), using mercury as the fluid; and inches of water (inches wg), using water or oil as the fluid.

Instruments employing this principle are called manometers. The simplest form is the basic and well-known U-tube manometers as shown in *Figure 85 on page 80*. This device indicates the difference between two pressures or between a single pressure and atmosphere, when one side is open to atmosphere.

If a U-tube is filled to the halfway point with water, and air pressure is exerted on one of the columns, the fluid will be displaced. Thus, one leg of water column will rise and the other will fall. The difference in height, h , which is the sum of the readings above and below the halfway point indicated the pressure in inches of the water column.

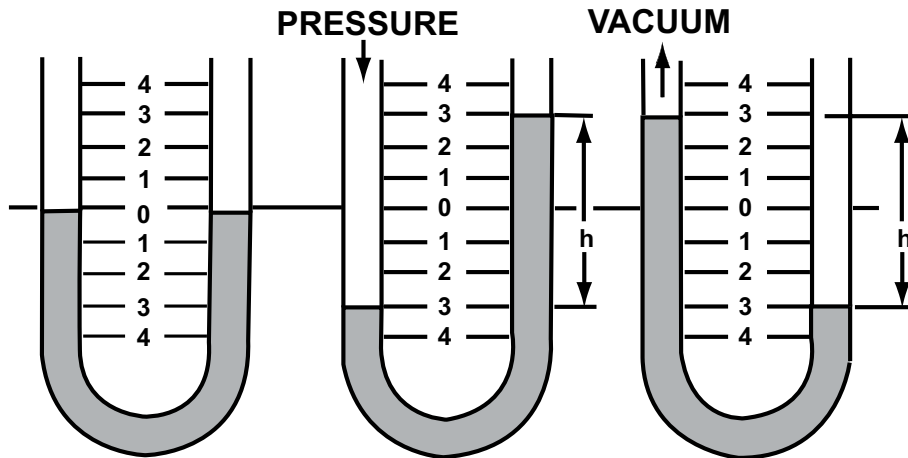

LD06364a

FIGURE 85 - U-TUBE MANOMETERS

The U-tube manometer is a primary standard because the difference in height between the two columns is always a true indication of the pressure regardless of the variations in the internal diameter of the tubing.

For use on all air units, the manometers should cover at least a 26 in. range as shown in *Figure 86 on page 80*.



LD27928b

FIGURE 86 - SLACK TUBE MANOMETER

DUCT PRESSURES

Velocity

When air moves at a given velocity (V) in FPM in a duct, it creates a pressure corresponding to the velocity, which is a measure of the kinetic energy in the fluid and is known as the velocity pressure (VP). VP is always exerted in the direction of air flow. The relationship between the velocity and the VP may be expressed by the following formulas:

$$V_p = \left(\frac{V}{4005} \right)^2$$

$$V = 4005 \sqrt{V_p}$$

$$4005 \sqrt{0.250} = 2002 \text{ FPM}$$

It is a simple matter to determine the velocity (FPM) of an the air stream so the VP can be measured. For example, if a Pitot Tube manometer hook-up reads 0.25 inches water, the previous equation should be substituted:

Static Pressure

Independent of its velocity, air, when confined within an enclosure such as a duct or tank, will exert itself perpendicularly to the walls of the enclosure. This is the compressive pressure existing in a fluid, and it is known as the static pressure (SP). Unlike VP, which is always positive, SP, when it is above atmospheric pressure will be positive but when below atmospheric pressure it will be negative. The discharge side of a fan in an air system will read a positive pressure, the inlet side will read a negative or minus pressure.

Total Pressure

Static pressure is exerted whether air is at rest or in motion. The algebraic sum of static pressure and velocity pressure gives the total pressure (TP).

$$Vp = TP - SP$$

The manometer does not sense the actual VP directly but by using the pitot tube hook-up with the static opening connected to the low pressure side of the gauge, and the total pressure opening connected to the high pressure side of the gauge, the manometer will read the difference between the two, or the VP.

VP and SP change in the ductwork with every change in the duct configuration, but the total pressure, on the other hand, remains constant. As a result, as the VP decreases, the SP increases and vice versa, because the SP is always the difference between the total pressure and the VP. However, in an actual duct system, the internal friction would cause a loss of total pressure.

The SP in an exhaust system is always below atmospheric pressure, and it is customary among ventilation engineers to omit the minus sign affecting the static (gauge pressure).

When the unit is designed for connection to a duct system, and the installing contractor assembles the ducts, elbows, registers, grilles, etc. to the outlet and/or inlet of the AHU, the SP drop through this external ductwork is called external SP as shown in *Figure 87 on page 81*.

The selected fans must be capable of moving the desired airflow through the entire air moving system including the AHU (internal SP), and the duct system (external SP).

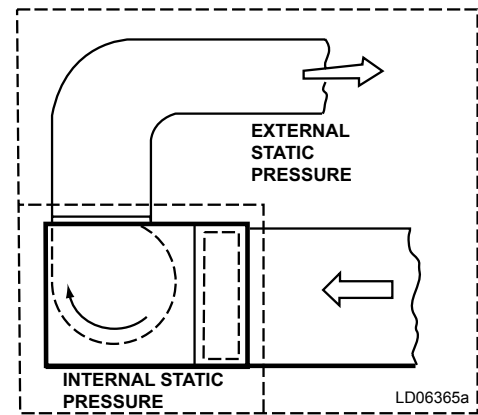

FIGURE 87 - STATIC PRESSURE AIR SYSTEM

At a given flow rate the internal pressure losses plus the external SP losses equal the system SP or the summation SP.

These pressures are important when troubleshooting for issues such as reduced capacity, vibration and noise. Changes in the cross sectional area of a duct (contractions or enlargements) cause changes in the velocity of the air flowing through the duct.

When the velocity decreases, the VP decreases. Some of the velocity energy is lost because where the area changes in the duct. Some of the velocity energy is converted into SP energy in the continuing ductwork. This conversion of velocity energy to SP is called static regain.

REQUESTING ASSISTANCE

When contacting Johnson Controls for assistance, provide the following information:

- Johnson Controls Order Number
- Job Name (not contractor)
- Unit Model Number
- Customer's Unit ID
- Design and actual data
 - Fan RPM.
 - Unit SP (across fan).– Unit CFM
 - Pressure drop of water across cooling coil (PSIG)
 - Air pressure drop across cooling coil
 - Temperature differential across cooling coil.
 - Motor voltage and amperes

- For fan or motor RPM, use a tachometer, stroboscope or revolution counter.
- The voltage and amperes can be obtained by using the appropriate multimeter test device.
- A sketch of the duct configuration would assist us in trying to resolve the problem.
- The most important item is to provide a detailed explanation of the problem.
- An orifice is the best method of measuring flow in piping and in the air system.

ADJUSTING, REMOVING, AND INSTALLING SHEAVES

Fixed Pitch Sheaves (T.B Woods With Sure Grip Bushings)

Tools and Materials Required

- Standard mechanic's hand tools
- Medium flat file
- Torque wrenches (0 to 250 in-lb)
- Hex (Allen) socket set for torque wrench
- Standard 3/8 in. or 1/2 in. socket set
- Hammer
- Fine Emery cloth
- Contact cleaner or mineral spirits

Removing Sheave

1. Remove the belts.
2. Remove the cap screws from bushing/sheave as shown in *Figure 88 on page 82*.

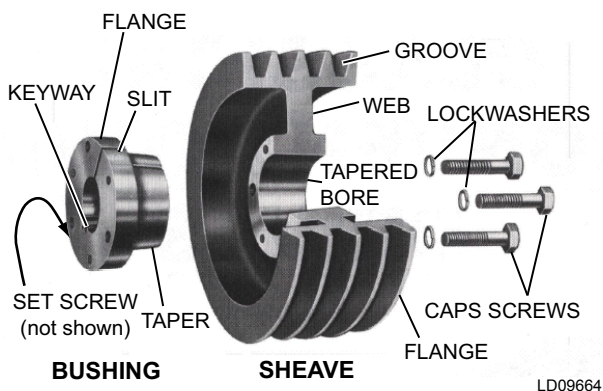
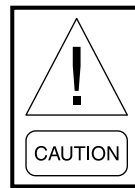

FIGURE 88 - INSERTING CAP SCREWS

3. Separate the sheave from the bushing.
4. **Standard Mounted** - Thread the cap screws into the threaded holes in the sheave. Hand tighten it-against bushing flange.
5. **Reverse Mounted** - Thread the cap screws into the threaded holes in bushing. Hand tighten it against the sheave web.
6. Tighten each cap screw gradually and evenly in rotation to push the sheave off the taper of the bushing. Tap lightly with a hammer, if necessary.
7. Remove or loosen the set screw from the flange of the bushing. Inspect it, and if necessary, replace it.
8. Pull the bushing off of the shaft. If the bushing will not come off, insert a screwdriver into the slit in the bushing.
9. Remove the key from the keyway.

Installing Sheave



Do not use lubricants in this installation. Bushing and sheave mating surfaces must be clean and oil free.

1. Inspect the tapered bore of the sheave and the tapered surface of the bushing. Remove any paint, dirt, oil or grease.
2. Select the type of mounting that best suits this application as shown in *Figure 89 on page 82* and *Figure 90 on page 83*.

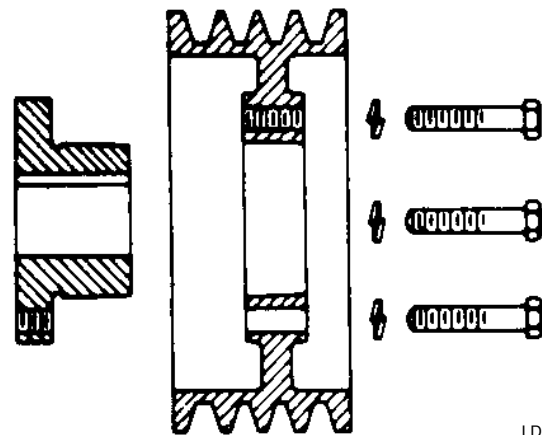

LD05630

FIGURE 89 - STANDARD MOUNTING

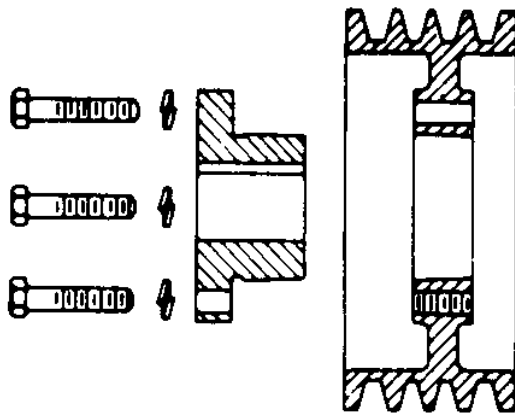

LD05631

FIGURE 90 - REVERSE MOUNTING



Excessive wedging will split the bushing.
Do not tighten the set screw to standard torque values at this time.
Do not use the lubricant on the cap screws.

Standard Mounting

1. Install the shaft key. If a key was furnished with the bushing, use that key.
2. Install the bushing on the clean shaft, flange end first. If the bushing will not freely slide onto the shaft, insert a screwdriver or similar object into the flange sawcut to act as a wedge to open the bushings bore.
3. If using the set screw, tighten it enough to prevent the bushing from sliding onto the shaft.
4. Slide the sheave into position on the bushing, aligning the drill holes in the sheave with the tapped holes in the bushing flange.
5. Loosely thread the caps crews with the lock washers into the assembly.

Reverse Mounting

1. With large end of the out, slide the sheave onto the shaft as far as possible. Install the shaft key.
2. If a key was furnished with bushing, use that key.
3. Install the bushing onto the shaft so that the tapered end will mate with the sheave.
4. If using the set screw, tighten it enough to prevent the bushing from sliding onto the shaft.

- a. Pull the sheave up onto the bushing, align the drilled holes in the bushing flange with the tapped holes in the sheave.
- b. Loosely thread the cap screws with lock washers into the assembly.

Using a torque wrench, tighten all the cap screws evenly and progressively in rotation to the torque value as shown in *Table 19 on page 83*. There must be a gap between the bushing flange and sheave hub when installation is complete.



Do not over torque. Do not attempt to close the gap between the bushing flange and the sheave hub.

TABLE 19 - CAP SCREW TORQUE VALUES

TAPERED BUSHING	SIZE AND THREAD OF CAP SCREW	FT-LB TO APPLY WITH TORQUE WRENCH
QT	1/4 x 1	9
JA	No. 10-24	5
SH-SDS-SD	1/4-20	9
SK	5/16-18	15
SF	3/8-16	30
E	1/2-13	60
F	9/16-12	110
J	5/8-11	135

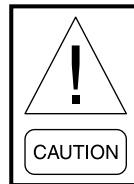

The tightening force on the screws is multiplied many times by the wedging action of the tapered surface. If extreme tightening force is applied, or if a lubricant is used, bursting pressures will be created in the hub of the mating part.

5. Tighten all set screws according to the values in *Table 20 on page 83*.

TABLE 20 - SET SCREW TORQUE VALUES

SET SCREW DIAMETER	HEX WRENCH SIZE ACROSS FLATS	MIN. RECOMMENDED TORQUE	
		IN-LB	FT-LBS
1/4	1/8	66 - 85	5.5 - 7.08
5/16	5/32	126 - 164	10.5 - 13.7
3/8	3/16	228 - 296	19.0 - 24.7
7/16	7/32	348 - 452	29.0 - 35.7
1/2	1/4	504 - 655	42.0 - 54.6
5/8	5/16	1104 - 1435	92.0 - 119.6

Adjusting Sheave

1. Before belts are installed, check alignment as described in *Belt Replacement Tensioning and Sheave Alignment for Top Mount* on page 58.
2. If adjustment is required, measure the space between the straight edge and the sheave.
3. Follow steps 2–5 under *Removing Sheave* on page 82 in this section. Move the bushing in the proper direction the distance measured.
4. Proceed with the instructions in *Installing Sheave* on page 82 in this section.

Adjustable Pitch Sheaves (T.B. Woods - Model JVS)

Tools and Material Required

- Standard mechanic's hand tools
- Medium flat file
- Torque wrenches (0-250 in-lb)
- Hex (Allen) socket set for torque wrench
- Square and straight edge
- Fine Emery cloth

Removing Sheave

1. Remove the belts.
2. Loosen both clamp screws with an Allen wrench as shown in *Figure 91* on page 84.

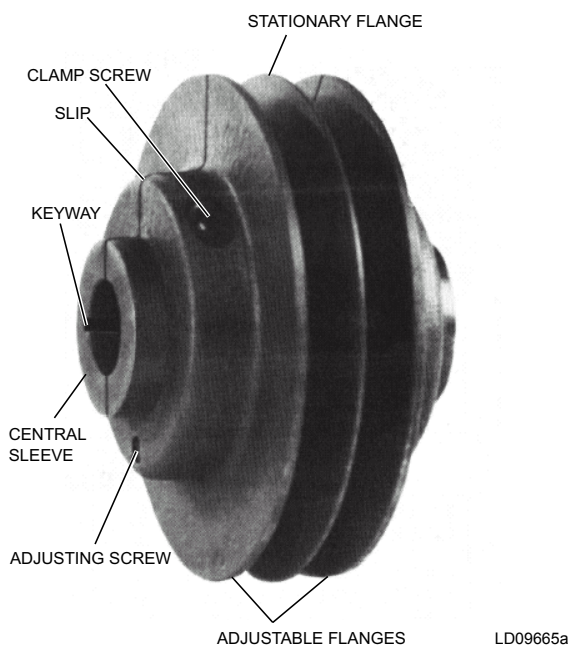

FIGURE 91 - ADJUSTABLE PITCH SHEAVE (JVS)

3. Clean and remove any burrs from the shaft from the sheave to the end.
4. Slide sheave off shaft. If tight, insert screwdriver into slit in central sleeve.

Installing Sheave

1. Loosen the clamp screws on the new sheave.
2. Slide the JVS sheave onto the shaft. Place the fan and motor sheaves on their respective shafts far enough to have the shaft exposed past its chamfer, which will facilitate proper alignment later in the process.
3. The central sleeve of this sheave is split at one end only. Install this end first as the split allows the sheave assembly to be secured to the shaft.
4. Adjust the sheave to the approximate pitch diameter desired. One turn of the adjusting screw will vary the pitch diameter 0.2 in. Seven turns are required to adjust the sheave from the minimum to the maximum pitch diameter.
5. Put slight finger pressure on the face of the adjustable flanges near the split (180 ° from the adjusting screw) to permit free and equal movement of the flanges during pitch adjustments. Otherwise, tipping and binding may occur.
6. Align the sheave with the companion sheave.
7. If there is a difference of more than 1/8 in. between the width of the companion sheave and any adjustable pitch sheave, align them, using Steps 5-6.
8. Alignment procedure for adjustable sheaves:
9. Use a square and straight edge to align the center or stationary flange of the adjustable sheave with the center flange of the companion sheave.
10. Insure the shaft of the motor is parallel to the shaft of the fan.
11. Tighten the two clamp screws to the following torque values:
 - JVS Model: 130- 160 in-lb. or 13 ft-lb
 - All other JVS Models: 325 in-lb or 27 ft-lb



Be careful not to grasp flanges in such a manner as to cock them while tightening the clamp screws.

12. Install the belts and tighten properly.
13. Recheck the alignment and speed.

Adjusting Sheave

1. To adjust the pitch diameter, loosen both clamp screws.
2. Remove the belts.
3. Follow Steps 3–8 in *Installing Sheave on page 82* in this section.

Adjustable Pitch Sheaves (T.B. Woods - Model FHP)

Tools and Material Required

- Standard mechanic's hand tools
- Medium flat file
- Torque wrench (0-250 in-lb)
- Hex (Allen) socket set for torque wrench
- Square and straight edge
- Fine Emery cloth

Removing Sheave

4. Remove the belts.
5. Loosen the set screws on the adjustable flange(s) of the sheave (Allen wrench) as shown in *Figure 92 on page 85*.

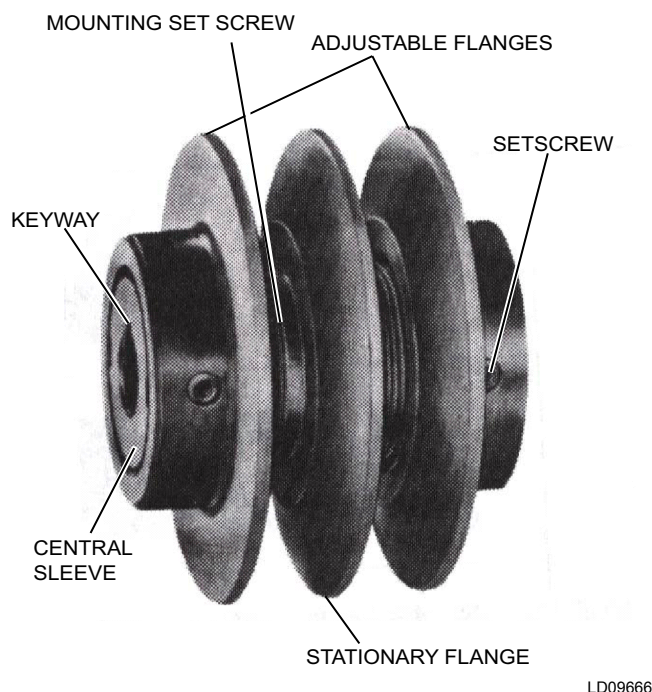

FIGURE 92 - ADJUSTABLE PITCH SHEAVE (FHP)

6. Screw the adjustable flange(s) open to expose and loosen the mounting setscrew in the central sleeve over the key.
7. Clean and remove any burrs from the shaft from the sheave to end.
8. Slide the sheave off of the shaft.

Installing Sheave

1. Loosen set screws on adjustable flange(s) of new sheave (Allen wrench).
2. Screw the adjustable flange(s) open to expose and loosen the mounting setscrew in the central sleeve over the keyway.
3. Inspect the shaft and key for any nicks and burrs. Remove same and clean shaft.
4. Insert the key into the keyway.
5. Slide the new sheave onto the shaft with the mounting setscrew over the key and toward the motor.
6. The fan and motor sheaves should be placed on their respective shafts far enough to have the shaft exposed past its chamfer, if possible, which will facilitate ease of alignment later in this process.
7. Align the adjustable sheave's stationary flange with the respective flange of the companion sheave. On adjustable sheaves of two or more grooves, if there is a difference of more than 1/8" between the width of the companion sheave and any adjustable pitch sheave, align using Steps 7–10.
8. Alignment procedure for multiple groove adjustable sheaves:
9. Use a square and straight edge to align the center or stationary flange of the adjustable sheave with the center flange of the companion sheave.
10. Insure the shaft of the motor is parallel to the shaft of the fan.
11. Secure the adjustable sheave to the shaft by tightening the setscrew over the key to the proper torque value.
12. Adjust the sheave flange(s) to the desired pitch diameter. Each turn of the flange changes the pitch diameter approximately 0.2 in. Six turns are required to adjust the sheave from minimum to maximum for A or B belts, and seven turns for 5V belts.



***Both flanges of a two-groove sheave
MUST be adjusted evenly.***

13. Lock the adjustable flange(s) in position by tightening the set screw(s) to the proper torque value.
14. To prevent damage to the central sleeve threads, the set screws **MUST** be over one of the flat areas of the central sleeve. If the flange is not properly locked, the sheave will fail rapidly.
15. Install the belts and tighten properly.
16. Recheck the alignment and speed.

Adjusting Sheave

1. Remove the belts.
2. To adjust pitch diameter loosen setscrew(s) on adjustable flange(s) of sheave.
3. Follow Steps 9–12 in *Installing Sheave on page 82* in this section.

SECTION 5 - WIRING DIAGRAMS



External wiring, unless specified as an optional connection in the manufacturer's product line, is not to be connected inside the control panel cabinet. Devices such as relays, switches, transducers and controls may not be installed inside the control panel. No external wiring is allowed to run through the control panel. All wiring must be in accordance with Johnson Controls published specifications and must be performed only by qualified Johnson Controls personnel. Johnson Controls will not be responsible for damages/problems resulting from improper connections to the controls or application of improper control signals. Failure to follow this will void the manufacturer's warranty and cause serious damage to property or injury to persons.



Do not penetrate the wireways in any manner. These sheet metal channels, which run along the top panel, contain electrical wires and connections. Electrical shock and/or damage to the unit may result.

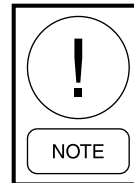

The purpose of drawings in this section is to aid in installation, start-up and troubleshooting. Actual wiring configuration may deviate from these drawings and are subject to change without notice.

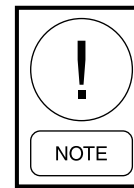

Never use silicone caulk/sealant or caulk/sealant containing silicone in or on any air handling equipment.



Rotating parts and electrical shock hazards exist. Follow the latest lock out and tag out procedures for the fan motor(s) and heat power disconnects before servicing. Failure to follow proper safety precautions may result in serious injury or death. Refer to the general safety guidelines and safety symbols located at the front of this manual.

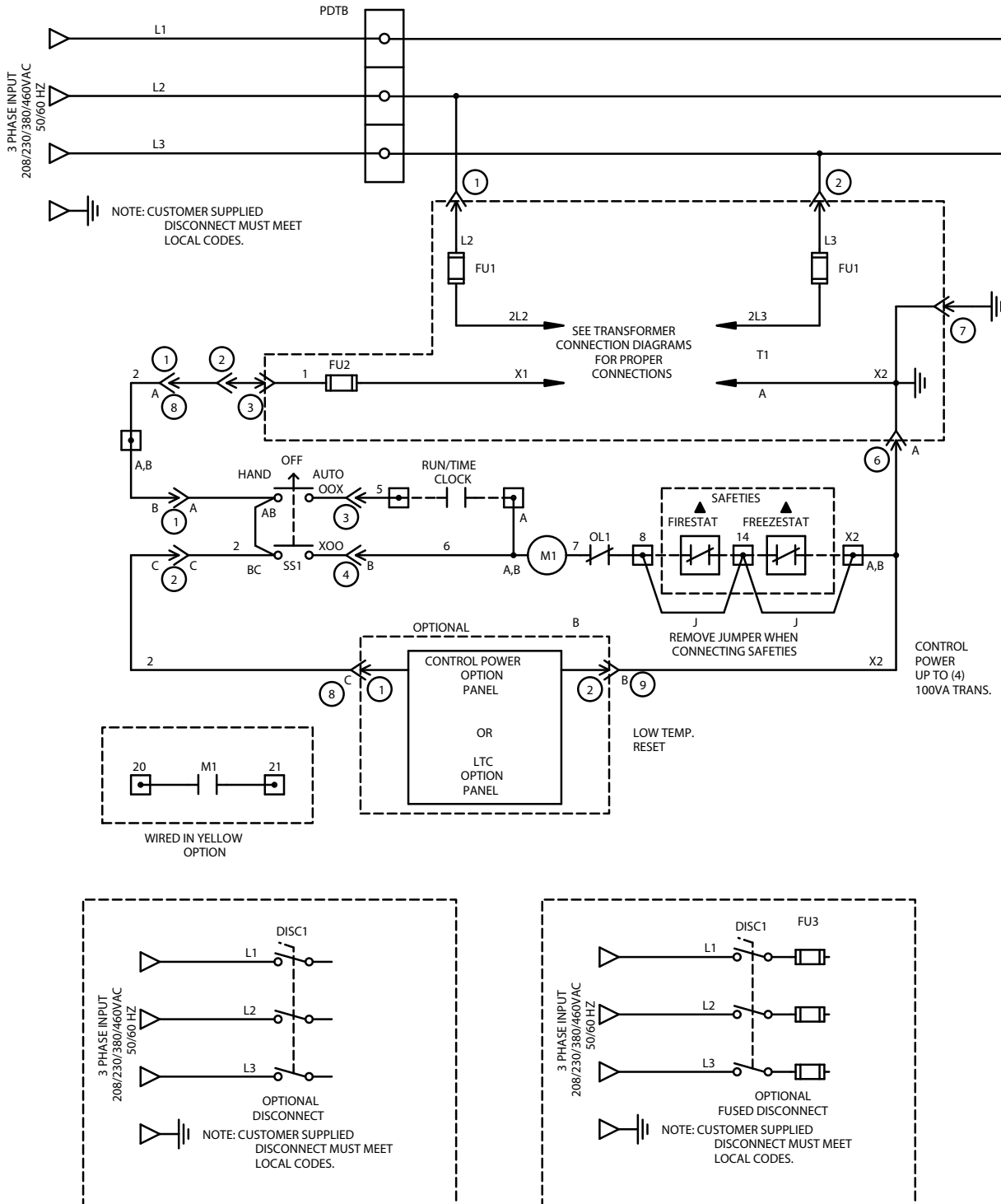

LD09683

FIGURE 93 - FULL VOLTAGE STARTER

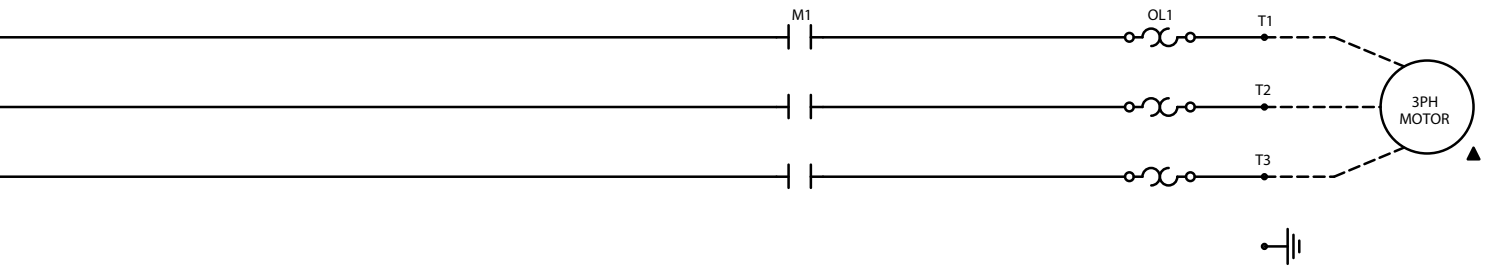

NOTES:

- ◻ - TERMINAL POINT
- ▲ - REMOTE DEVICE (BY OTHERS)

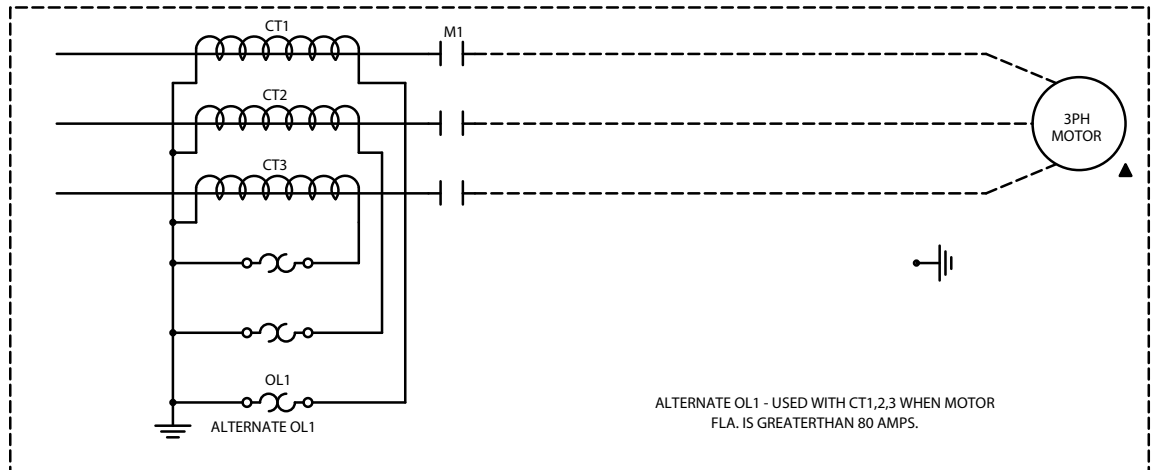

ALTERNATE OL1 - USED WITH CT1,2,3 WHEN MOTOR
 FLA. IS GREATER THAN 80 AMPS.

LD09683

FIGURE 93 - FULL VOLTAGE STARTER (CONT'D)

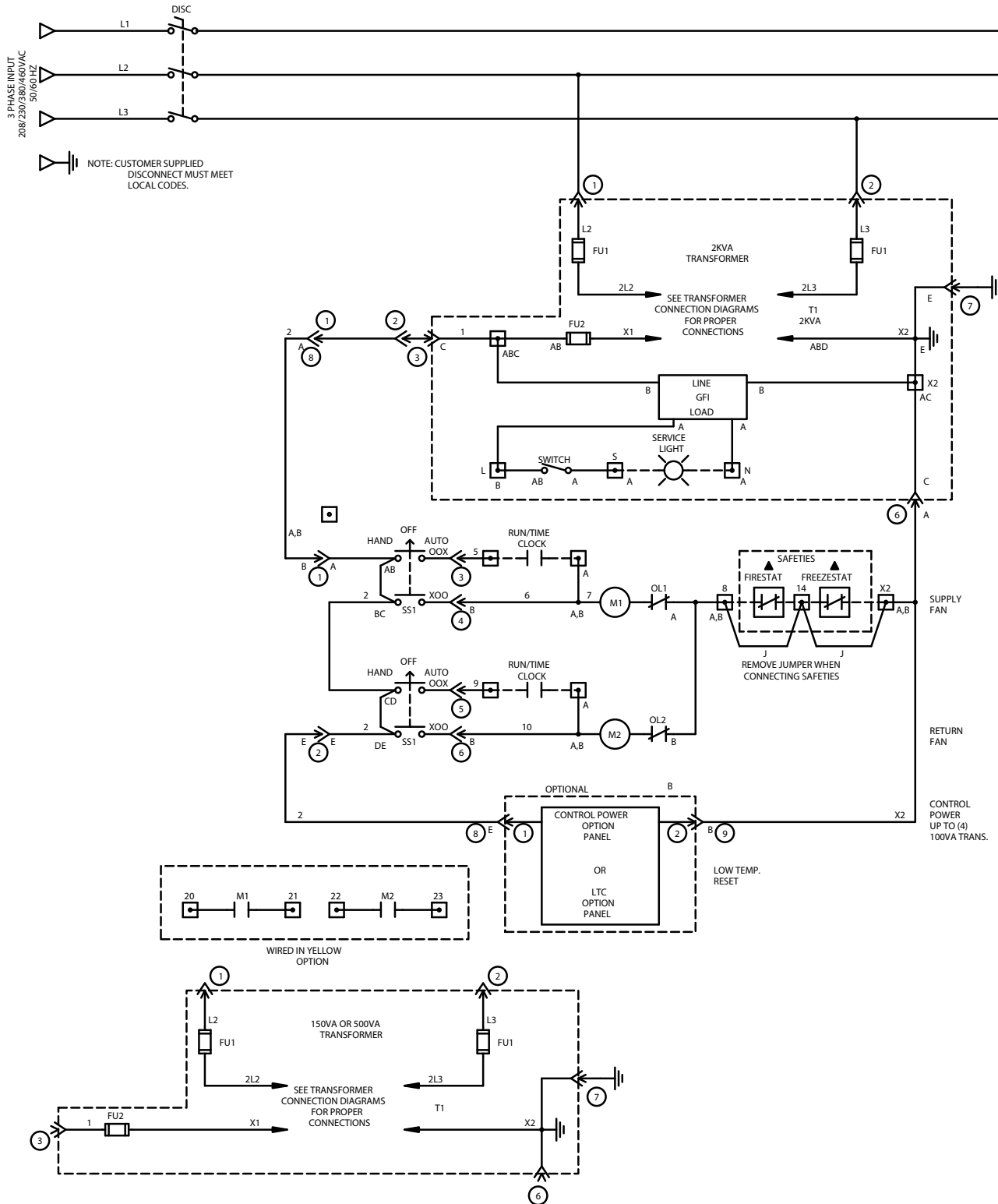

LD09684

FIGURE 94 - FULL VOLTAGE STARTER WITH SINGLE POINT POWER CONNECTION (204195)

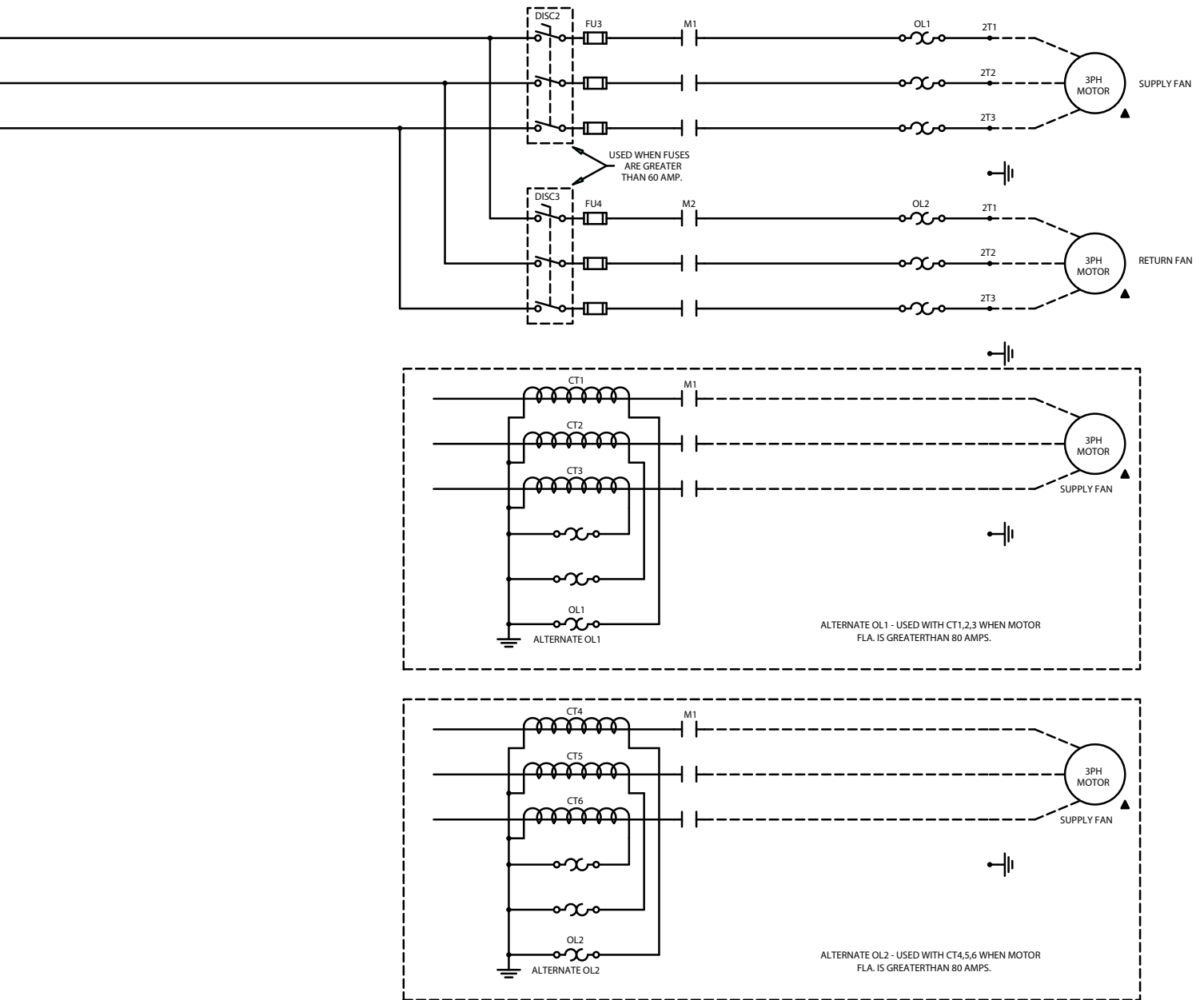

NOTES:

- ◻ - TERMINAL POINT
- ▲ - REMOTE DEVICE (BY OTHERS)

LD09684

FIGURE 94 - FULL VOLTAGE STARTER WITH SINGLE POINT POWER CONNECTION (204195) (CONT'D)

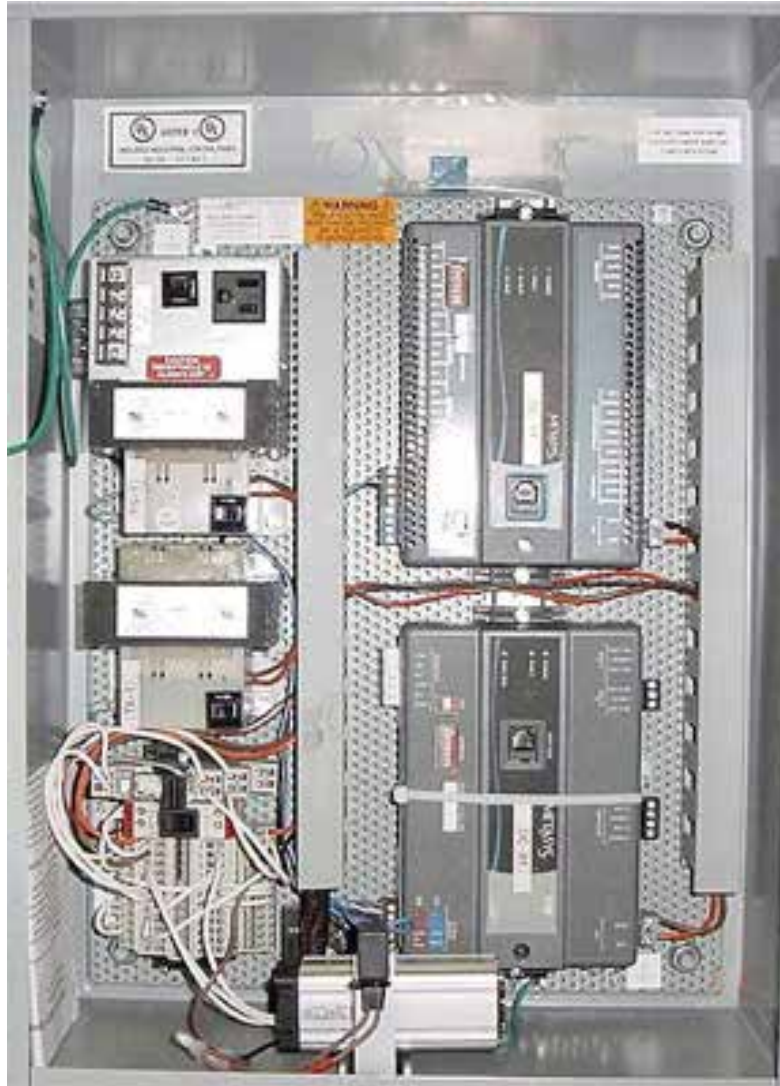

LD12500

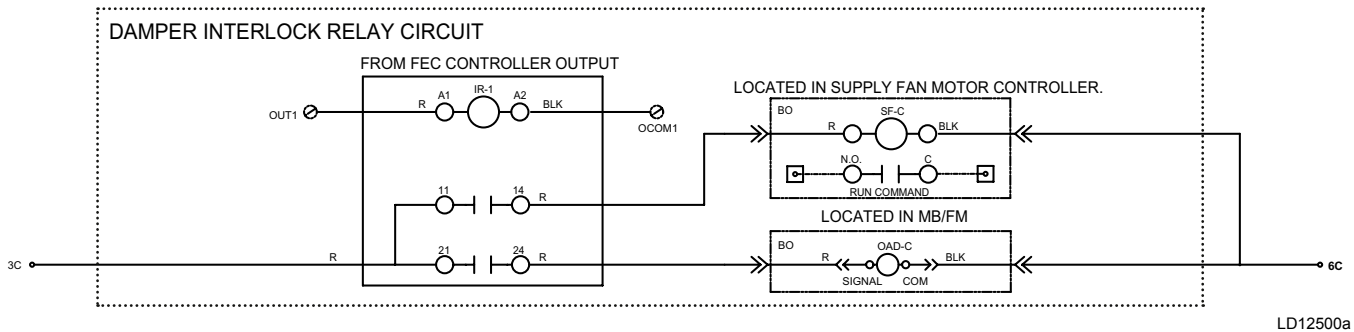

LD12500a

FIGURE 95 - OUTSIDE AIR DAMPER KIT (RELAY INSTALLATION)

INSTALLING KIT (IF APPLICABLE)

1. This kit will be required for some of Johnson FEC control standards (100% outside air).
2. Install relay (P/N 025-39136-001) on the DIN rail provided in the panel.
3. Wire the relay as shown in s shown in *Figure 95 on page 92*, using the wire called for in the kit.

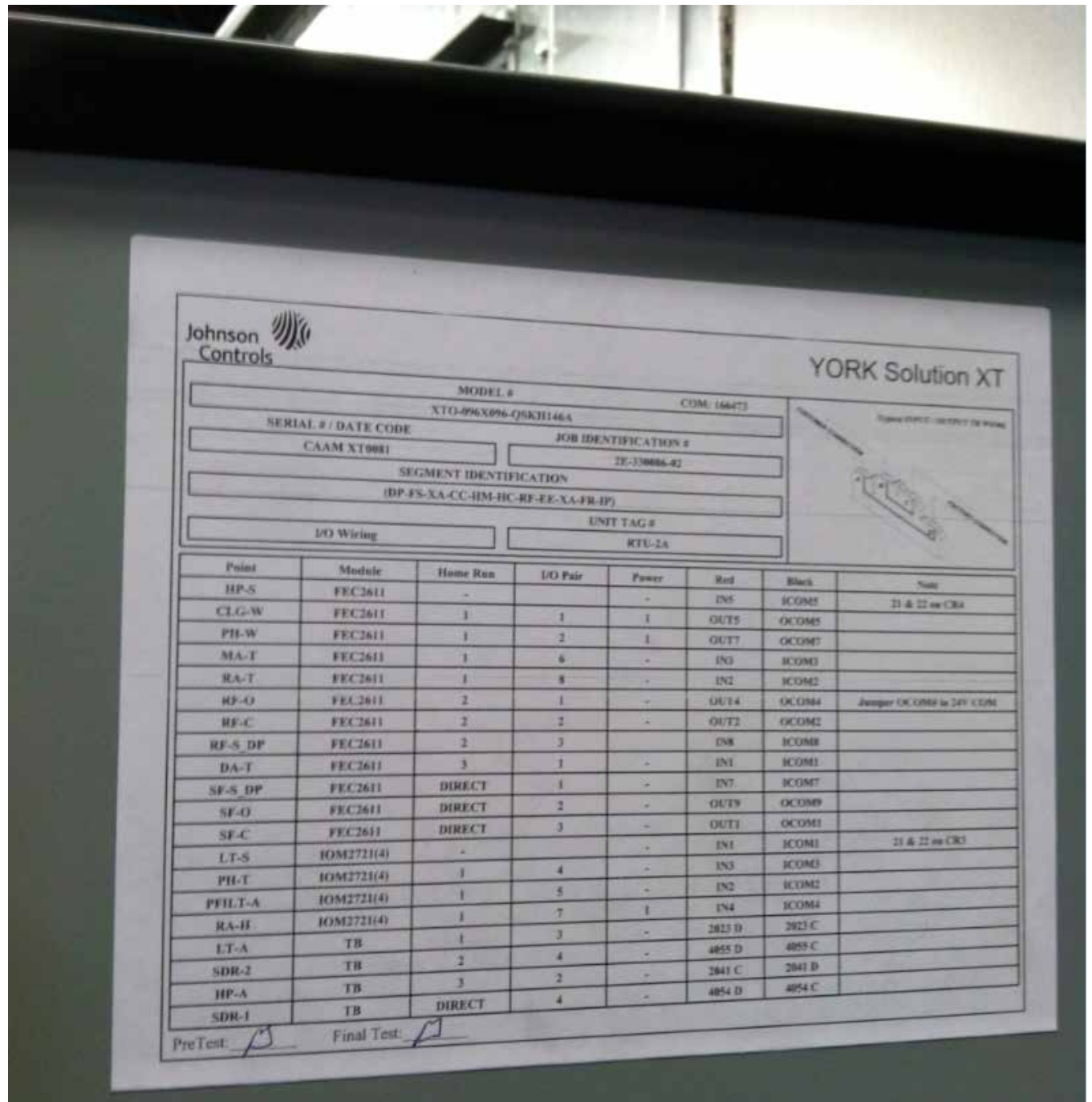

Termination Chart

FIGURE 96 - SOLUTION XT TERMINATION CHART INSIDE ENCLOSURE DOOR

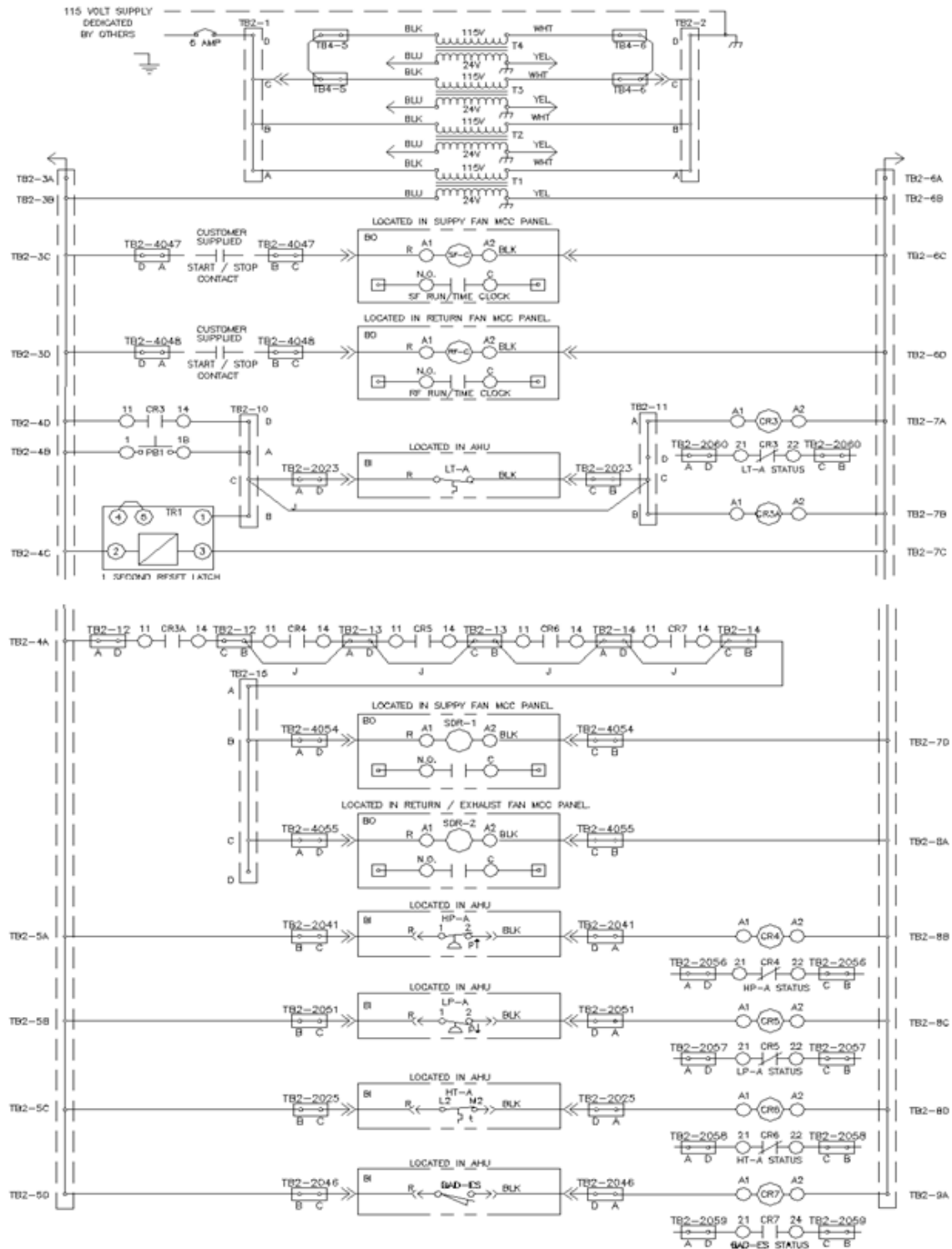

LD17195

FIGURE 97 - TYPICAL FPC WIRING DIAGRAM

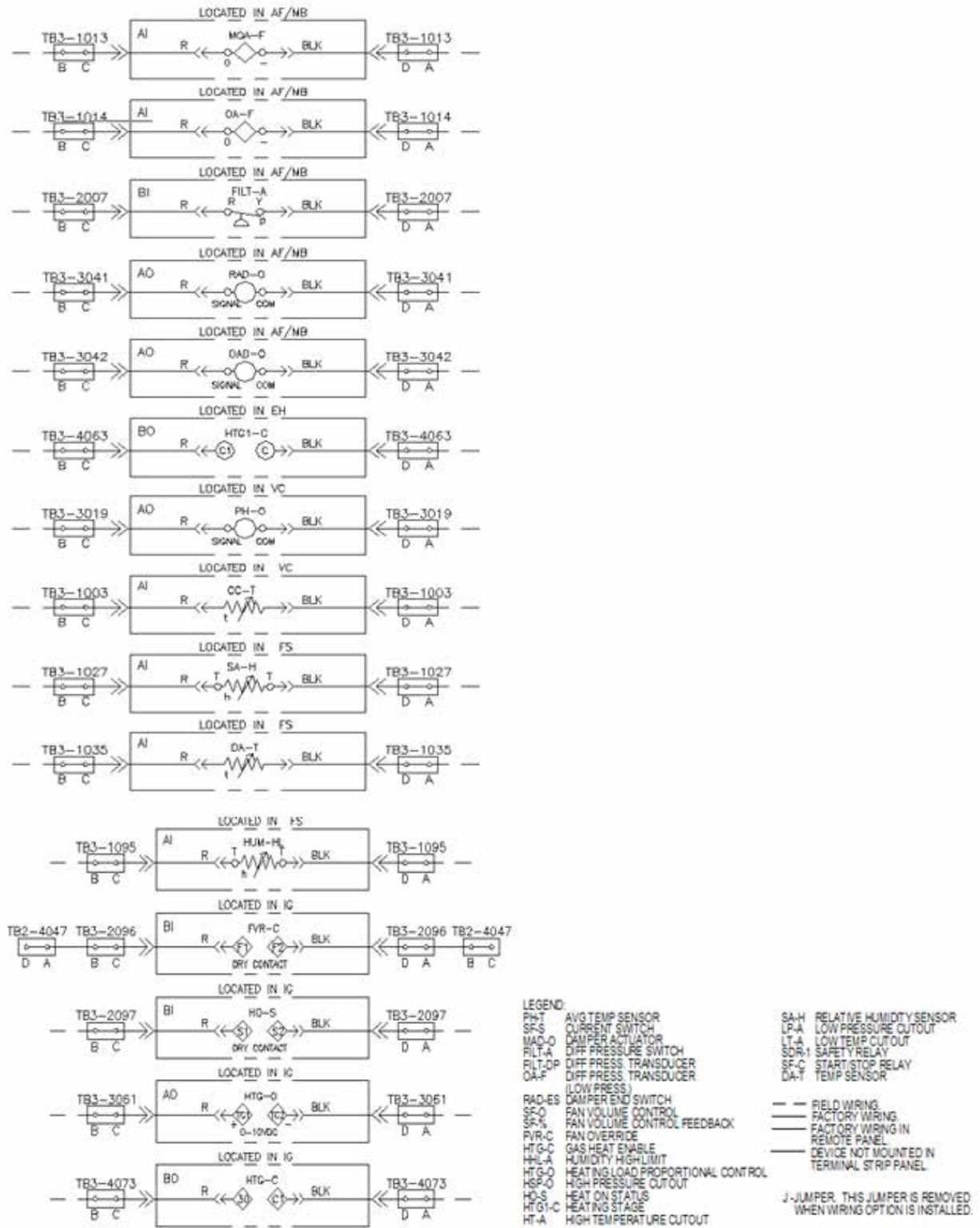
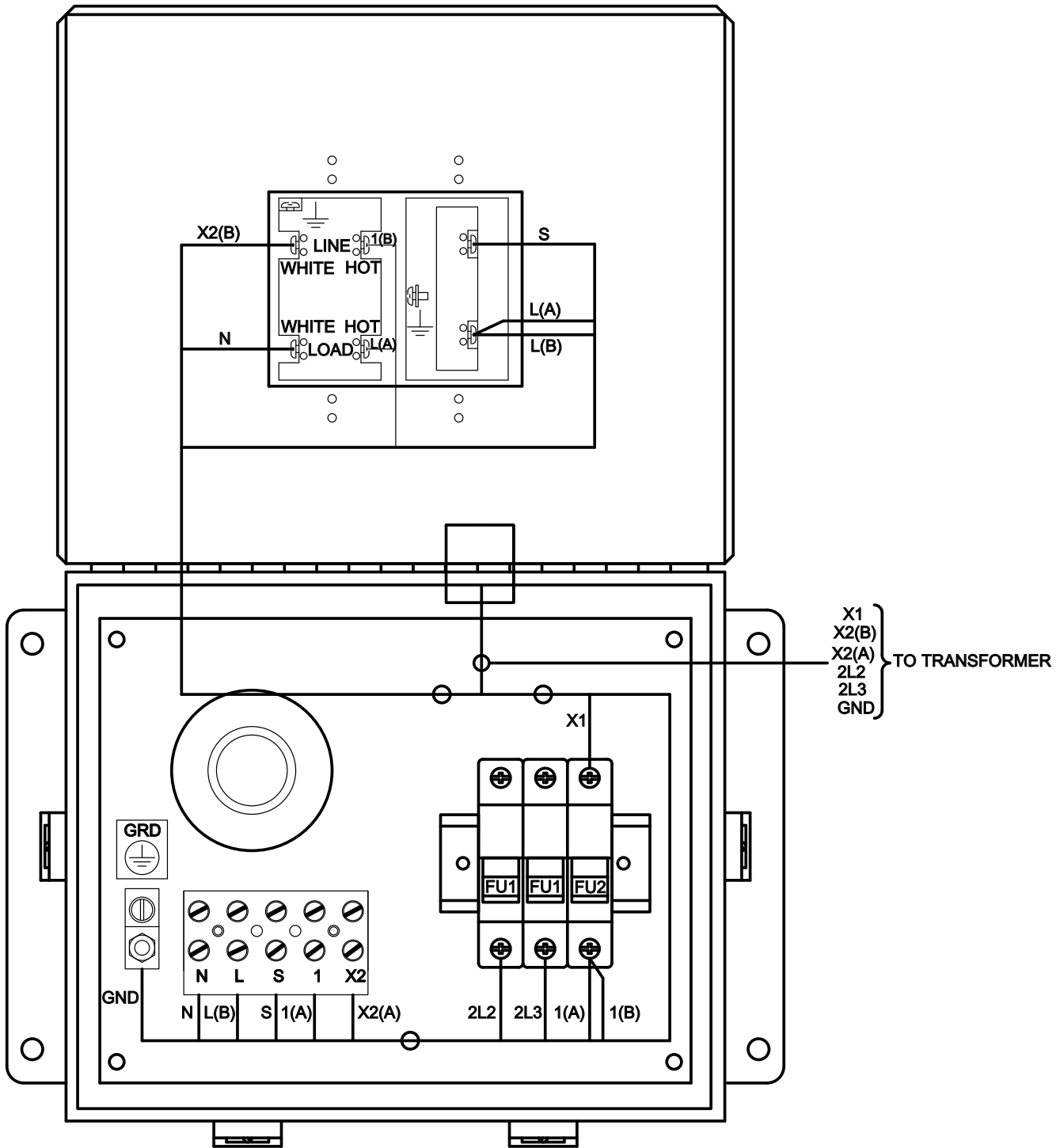

FIGURE 97 - TYPICAL FPC WIRING DIAGRAM (CONT'D)

LD17196



LD09691

FIGURE 98 - TRANSFORMER ENCLOSURE WIRING DETAIL (SHOWN OPEN)

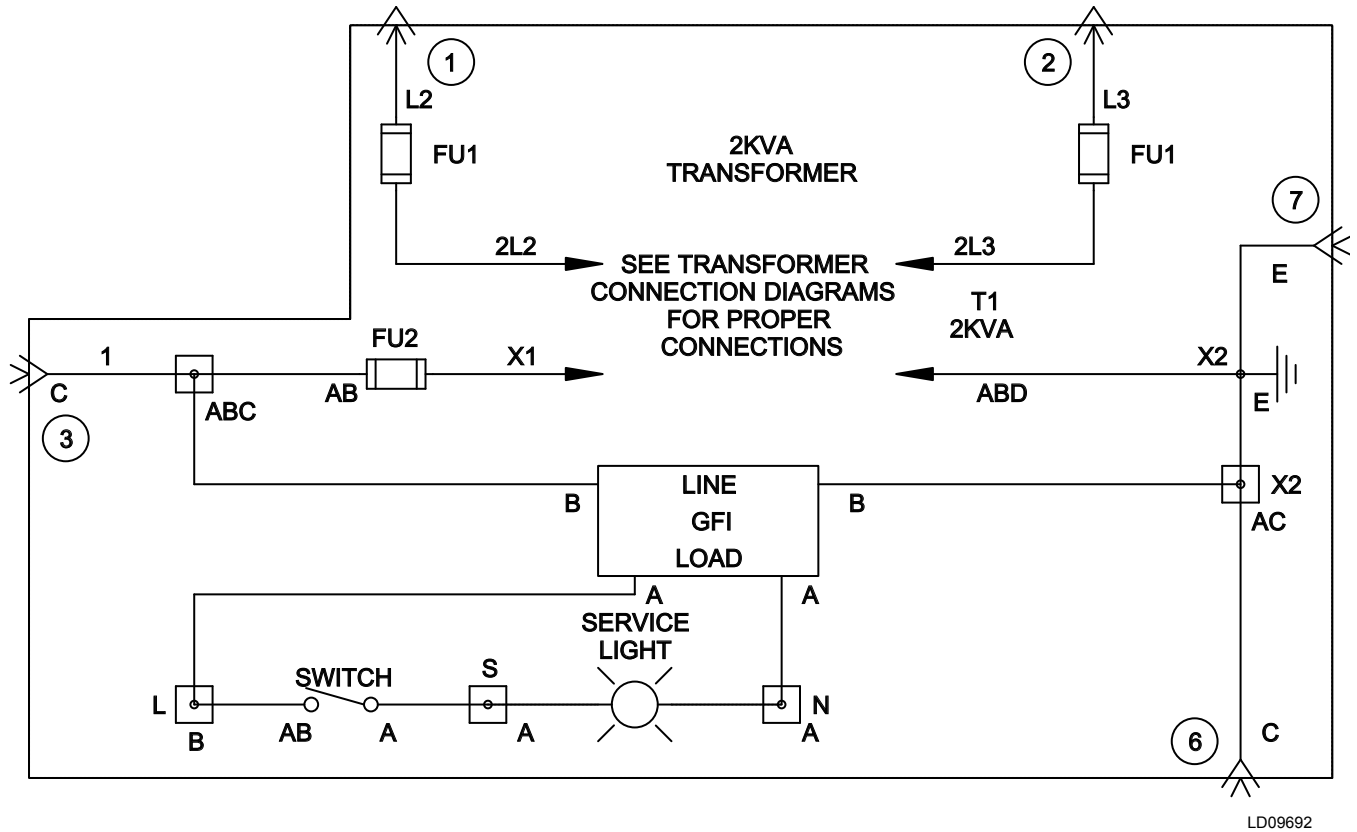

FIGURE 99 - TRANSFORMER WIRING DIAGRAM

THIS PAGE INTENTIONALLY LEFT BLANK.

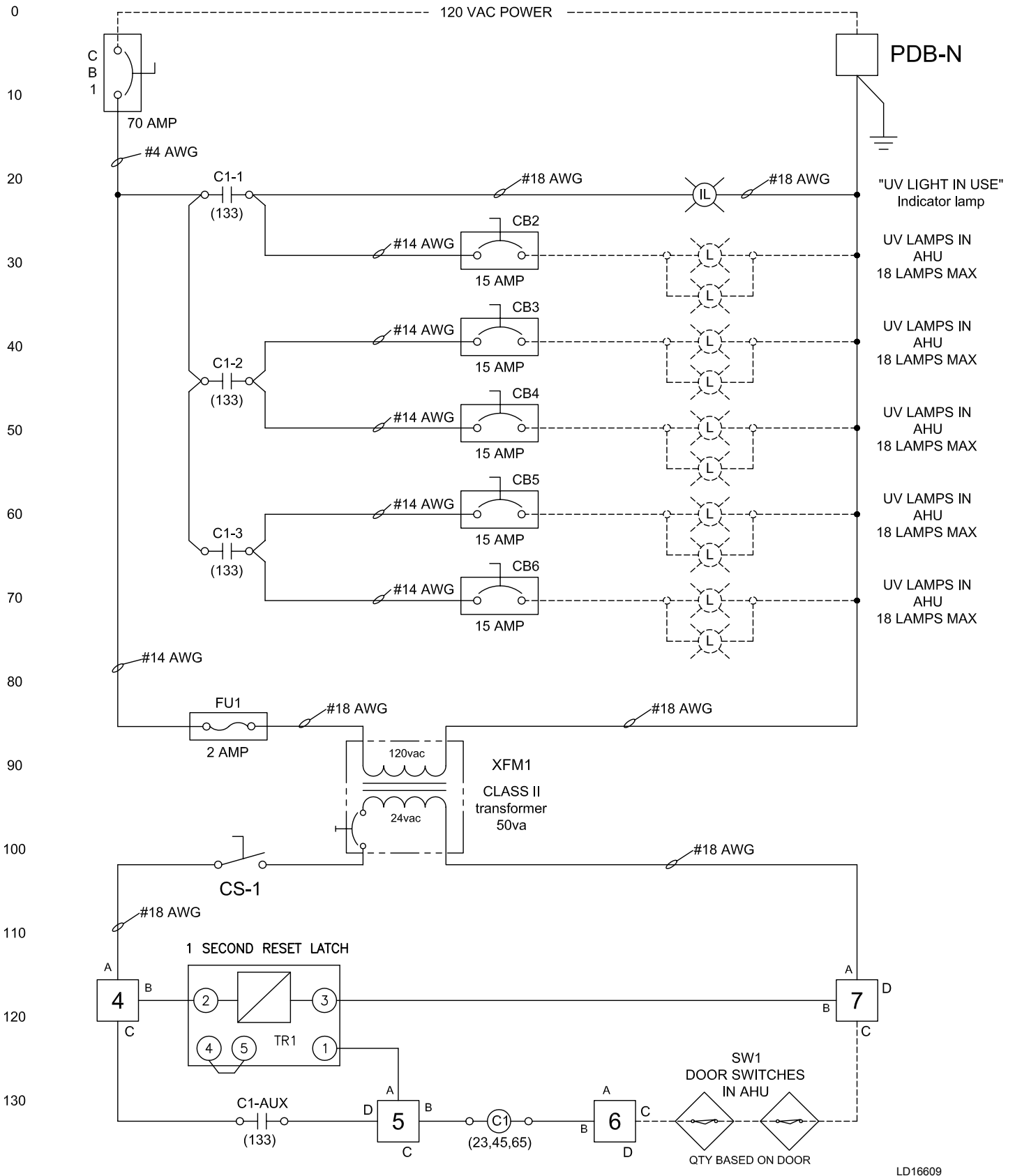
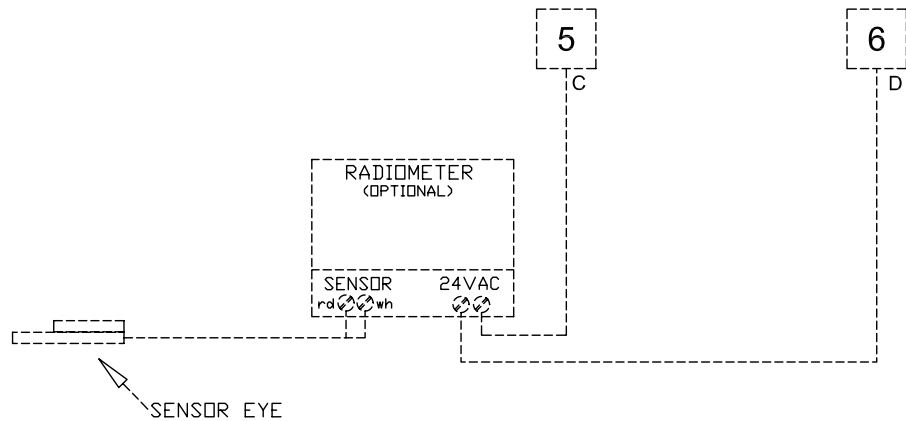

FIGURE 101 - UV CONTROL PANEL WIRING (GREATER THAN 8 AMPS)

OPTIONAL RADIOMETER WIRING.



Sequence of Operation:

Disconnecting Means of UV lighting will be accomplished by "CB1" internal to the panel. "CB1" is cable of being locked out by panel latching mechanism.

"SW1" is a proximity switch with a magnet, which will close a set of normally open contracts. The magnet will engage the "SW1" contact whenever it is within 1/2" of the switch.

"TDR1" is one second (1sec) time delay relay having normally open contacts. When power is initiated, its contacts will close for one second then re-open. To reset, power, power must be removed from "TDR1"

"C1" is a dpdt 24 vac control relay, used to seal-in its coil and provide interlocking means to the UV lights.

If all doors are closed, all the "SW1"s will allow "C1" to energize, as long as power is available.

By selecting "CS-1" to the "on" position, the 24vac control power circuit will be energized. As long as all doors with door switches (SW1) are closed and upon detection of power to the 1 second time-delay realy (TDR-1), the "TDR-1" normally open contracts will close for one second, energizing the contactor "C1" will remain energized. Should any one door having "SW1" mounted, were to open, "C1" will de-energize, deactivating the UV lamps. Closing all doors will not turn on UV lights. "CS-1" will be required, to be cycled "Off" then back "On" to allow the lights to come back on. If the power is removed from the UV control panell and re-energized (such as when power fluctuates off then back on), the UV lights will reactivate automatically. The "IL" "UV Light In USe" indcator lamp will allow the user to know if the lights have been energized.

LD16609

FIGURE 101 - UV CONTROL PANEL WIRING (GREATER THAN 8 AMPS) (CONT'D)

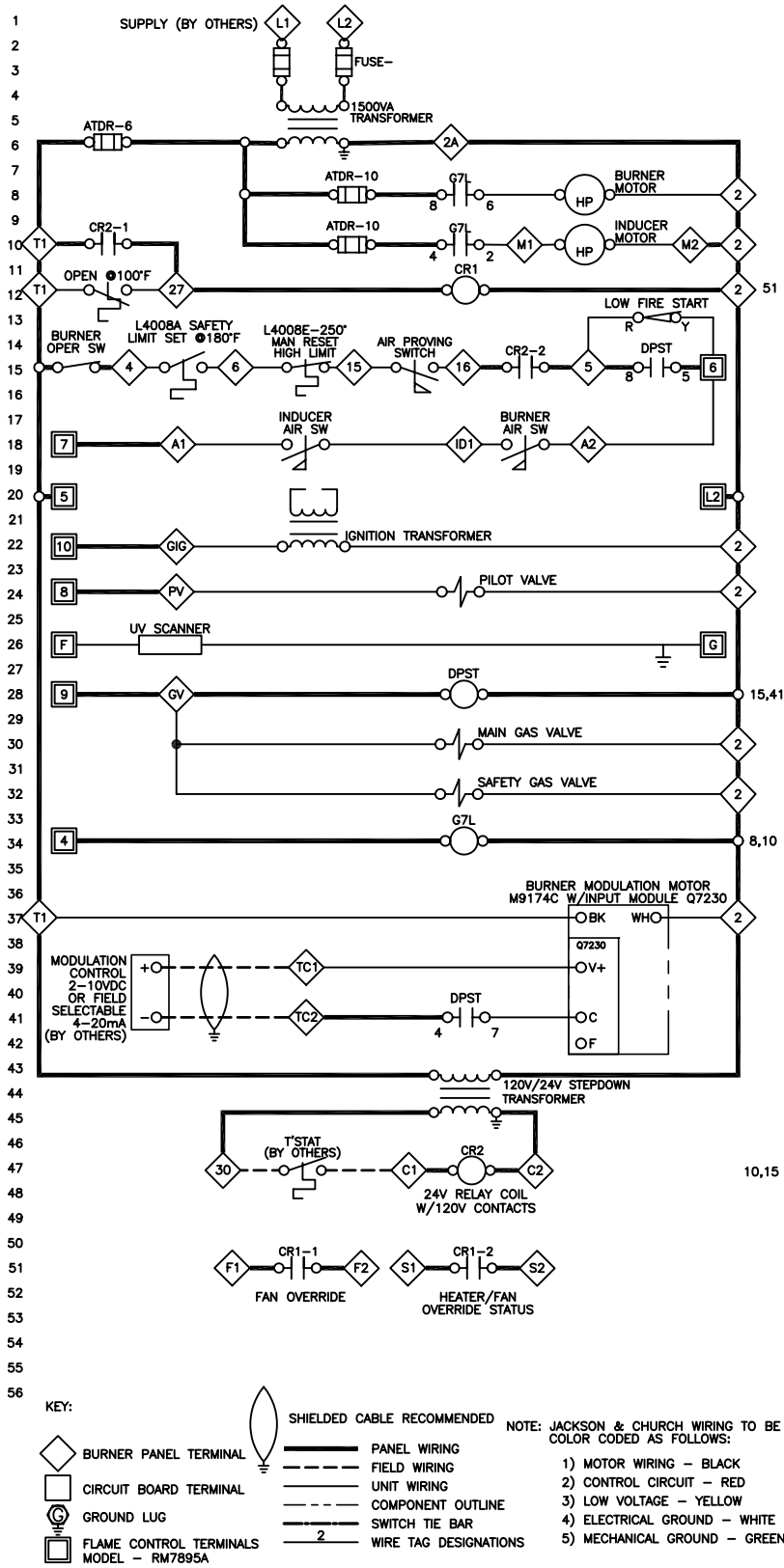

FIGURE 102 - GAS HEAT, SINGLE PHASE, 1500VA TRANSFORMER WIRING DIAGRAM

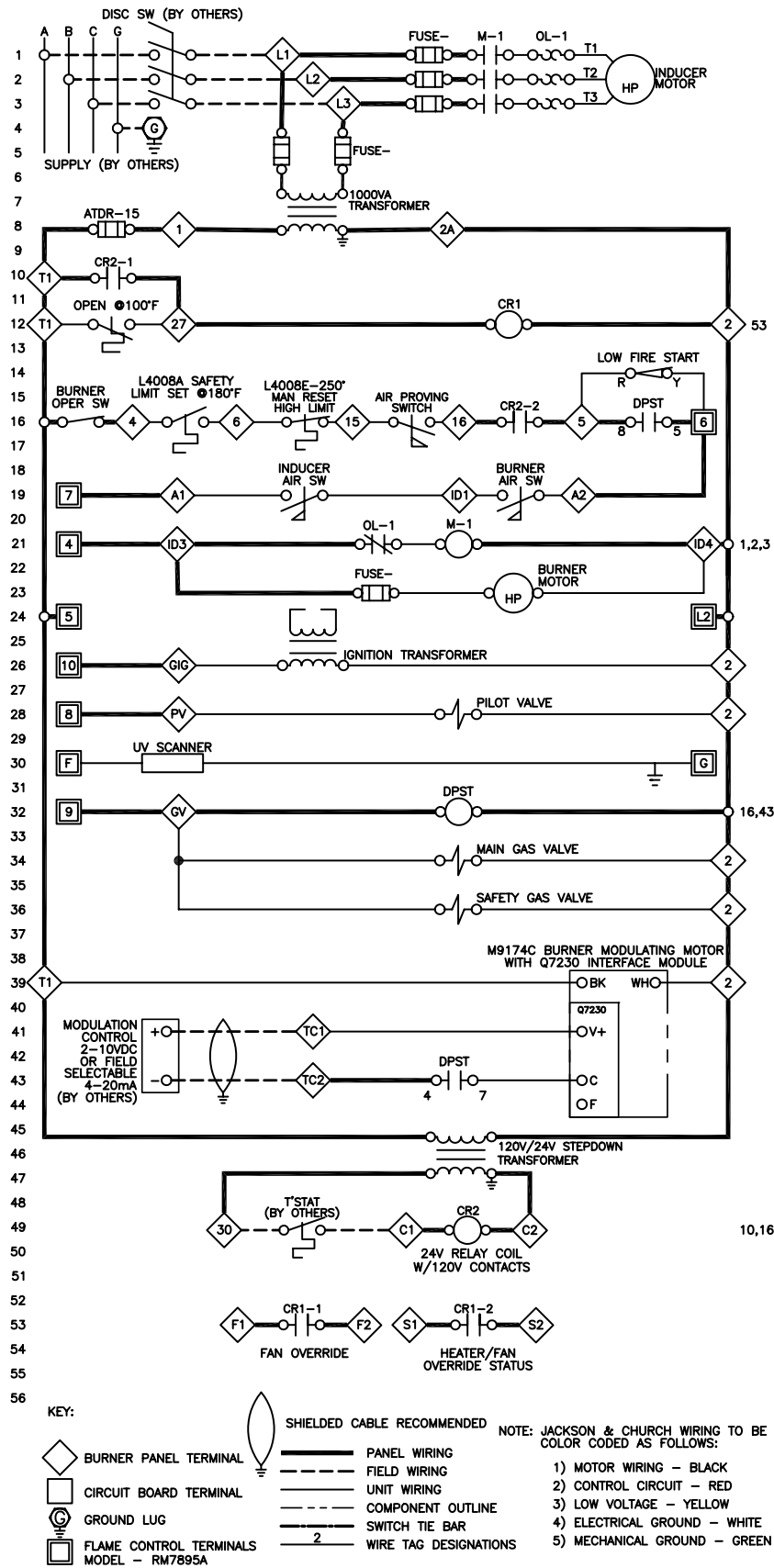

FIGURE 103 - GAS HEAT, THREE PHASE, 1000VA TRANSFORMER WIRING DIAGRAM

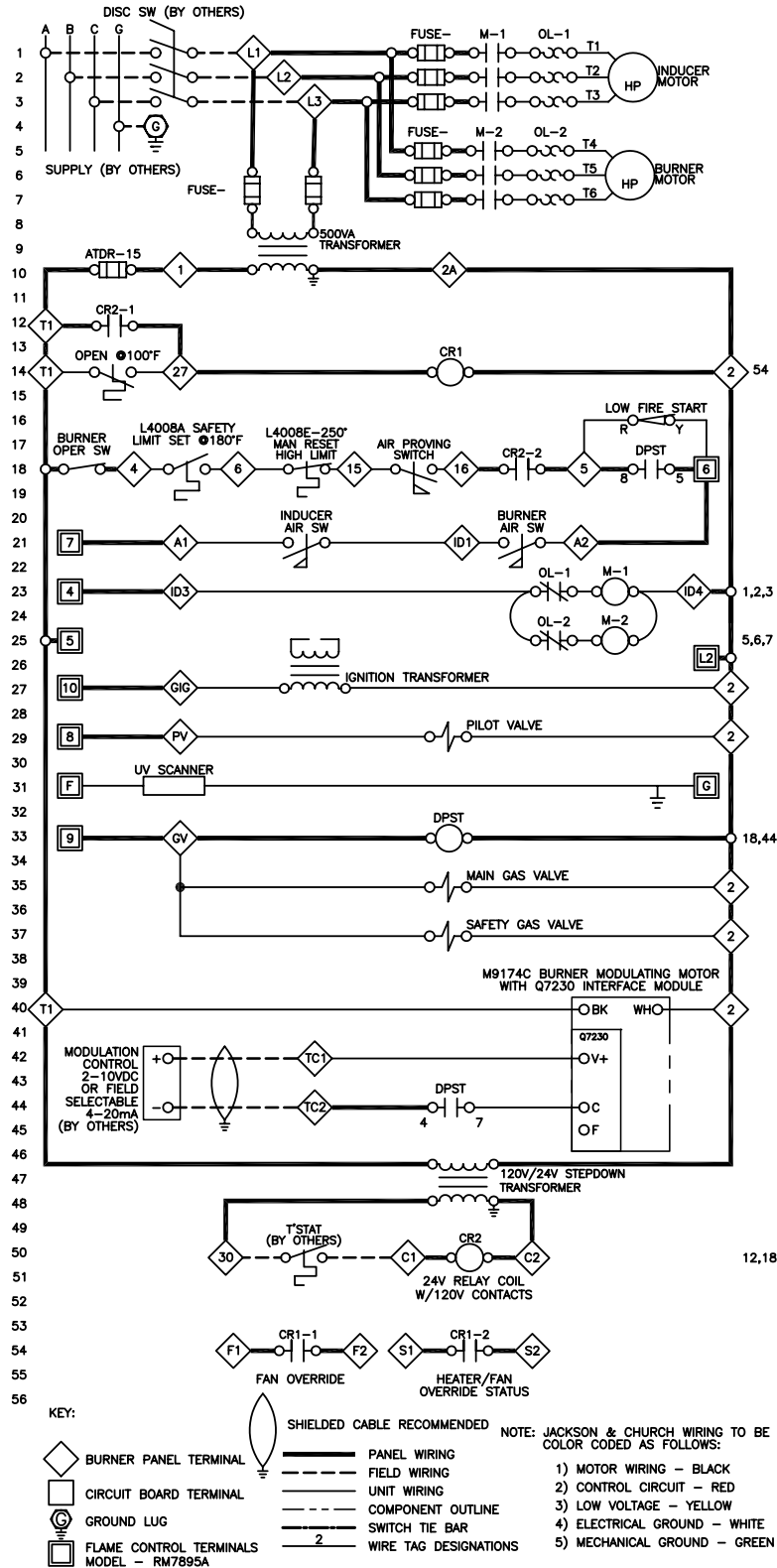

FIGURE 104 - GAS HEAT, THREE PHASE, 500VA TRANSFORMER WIRING DIAGRAM

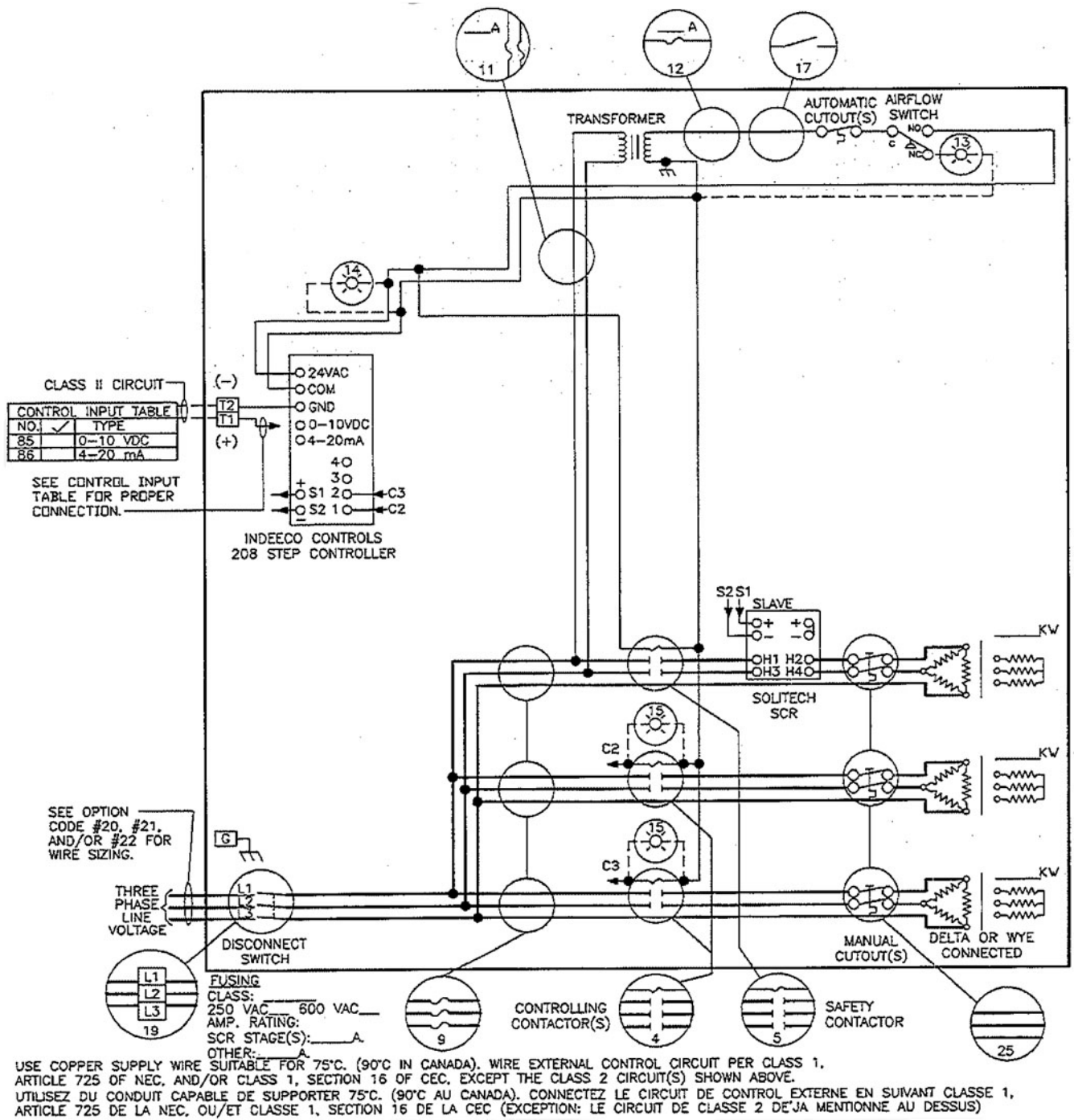
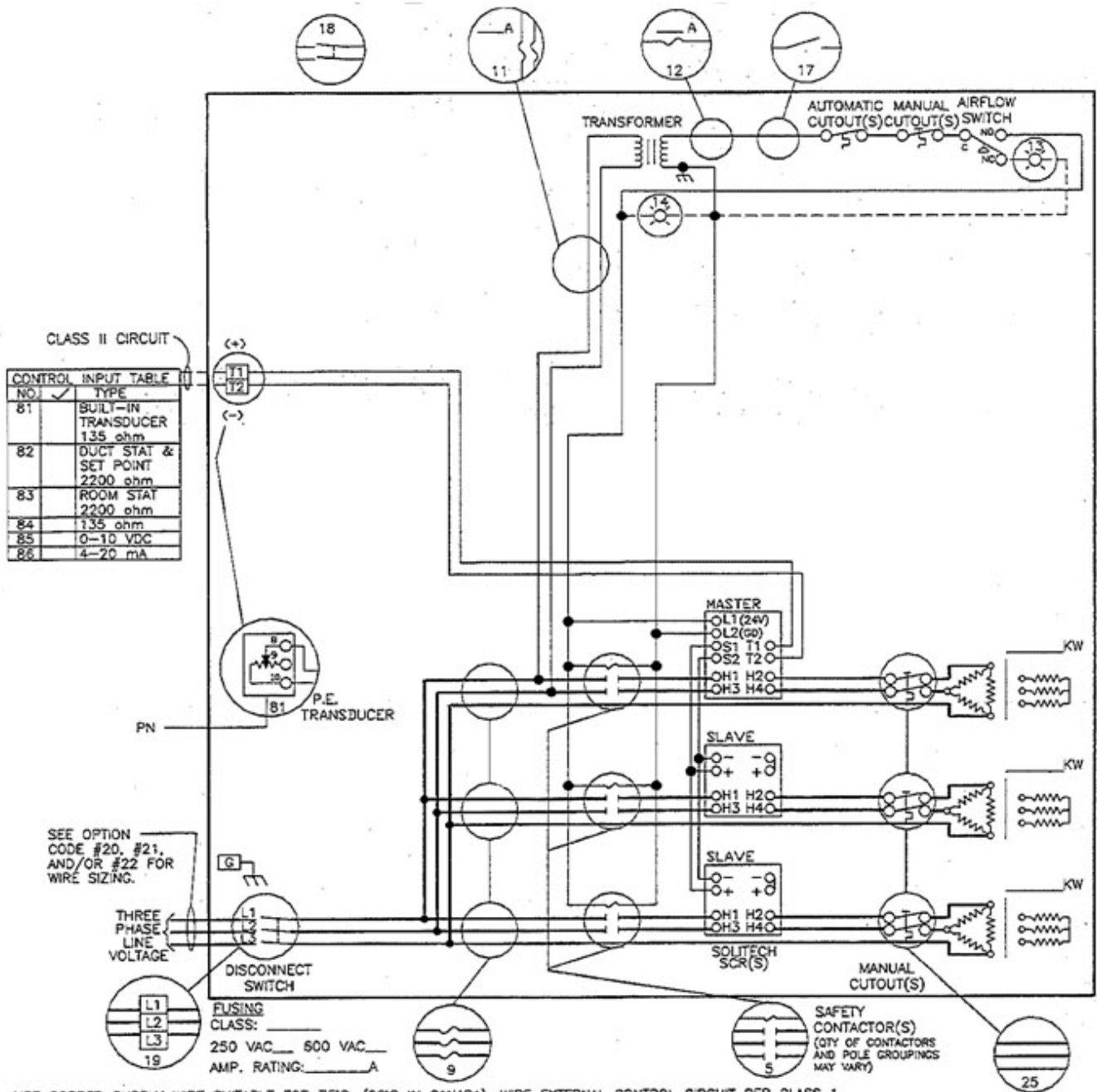

FIGURE 105 - TYPICAL WIRING DIAGRAM FOR ELECTRIC HEAT CONTROL TYPE VERMIER



USE COPPER SUPPLY WIRE SUITABLE FOR 75°C. (90°C IN CANADA). WIRE EXTERNAL CONTROL CIRCUIT PER CLASS 1, ARTICLE 725 OF NEC, AND/OR CLASS 1, SECTION 16 OF CEC, EXCEPT THE CLASS 2 CIRCUIT(S) SHOWN ABOVE.
 UTILISEZ DU CONDUIT CAPABLE DE SUPPORTER 75°C. (90°C AU CANADA). CONNECTEZ LE CIRCUIT DE CONTROL EXTERNE EN SUVANT CLASSE 1, ARTICLE 725 DE LA NEC, OU/ET CLASSE 1, SECTION 16 DE LA CEC (EXCEPTION: LE CIRCUIT DE CLASSE 2 DE JA MENTIONNE AU DESSUS)

LD16612

FIGURE 106 - TYPICAL WIRING DIAGRAM FOR CONTROL TYPE FULL SCR

APPENDIX A – START-UP CHECKLIST

 BY JOHNSON CONTROLS	AIR HANDLING UNITS
START-UP CHECKLIST	Supersedes: 100.00-CL1 (909) Form 100.00-CL1 (313)

AIR HANDLER START-UP CHECKLIST

OFFICE LOCATION _____	unit tag # _____
Qualified TECHNICIAN _____	unit model # _____
JOB NAME _____	UNIT SERIAL # _____
YORK JOB ID OR CONTRACT # _____	START DATE _____
JOB SITE LOCATION _____	
JOB SITE CONTACT AND PHONE # _____	

IMPORTANT SAFETY REQUIREMENT: FOLLOW THE LATEST "LOCK OUT TAG OUT" PROCEDURE.

PRE START-UP

GENERAL UNIT INSPECTION

Identify and perform appropriate "lock out/tag out" and safety rules. For details on points below see appropriate section of the Installation Instruction provided with each air handler.

For VFD equipped air handlers, refer to the VFD forms for additional requirements.



Serious damage to the AHU and/or system is eminent if the AHU is operated under any of the following conditions:

- Without proper control of dampers.

- With smoke dampers closed.
- During a fire alarm or smoke purge test.
- Any airflow restriction greater than normal.

Solution	AH Units	Form	102.20-OM1	Air Modulator	VFD Quick Start	Form	100.42-NO1
Custom	AH Units	Form	100.31-NOM1				
<input type="checkbox"/>	Equipment received as ordered.	<input type="checkbox"/>	Unit installed with proper clearances.	<input type="checkbox"/>	Unit checked for damage to interior and exterior.	<input type="checkbox"/>	Visually inspect roof curb for tight seal around unit.
<input type="checkbox"/>	Unit installed on flat and level surface. Outdoor unit mounted within roof slope limitations where applicable.	<input type="checkbox"/>	All penetrations MUST be sealed. All conduits MUST be sealed internally.	<input type="checkbox"/>	Terminal screws and wiring connections secure in control, electric and Air Modulator panels.	<input type="checkbox"/>	Clean air filters installed properly and secured.
<input type="checkbox"/>	Air hoods installed properly.	<input type="checkbox"/>	Filter gauge set to zero.	<input type="checkbox"/>	Condensate drain properly trapped.	<input type="checkbox"/>	All field wiring complete and inspected.
<input type="checkbox"/>	All wiring and tubing connections made at shipping splits.	<input type="checkbox"/>	All shipping splits sealed and secured properly.	<input type="checkbox"/>	All field piping connections complete.	<input type="checkbox"/>	Pipe chase floor sealed at penetrations.
<input type="checkbox"/>	All shipped loose parts installed.	<input type="checkbox"/>	All shipping bolts and other material have been removed. (Fan, VIFB, Energy Recovery Wheel, Damper).	<input type="checkbox"/>	Installer has cleaned out interior.	<input type="checkbox"/>	Damper linkage is tight and in correct "power off" position.
<input type="checkbox"/>	Verify all plug-ins and wire connections are tight on UV equipment.	<input type="checkbox"/>	Controls installation complete.	<input type="checkbox"/>	Verify Energy Recovery Wheel turns freely and wheel segments are fully engaged.	<input type="checkbox"/>	Verify all spacers removed from door edges.
<input type="checkbox"/>	Verify all ductwork is complete and available for full air flow.	<input type="checkbox"/>	Verify correct piping of split system. Reference Section 2 of Solution IOM & Split System Application Guide (050.40-ES3).				

Fan INSPECTION	
<input type="checkbox"/> Check bearings and locking collars for properly tightened setscrews, bolts and nuts.	<input type="checkbox"/> Fan wheel properly aligned, tight on shaft and freely moving.
<input type="checkbox"/> Sheaves properly aligned and tight on shaft.	<input type="checkbox"/> Check fan base isolators and thrust restraints for proper adjustment. Note: Do not remove functional bolts from seismic isolators.
<input type="checkbox"/> Belt tension adjusted properly per drive pkg. label on fan.	
<input type="checkbox"/> Check fan alignment with unit discharge. Adjust with isolation.	<input type="checkbox"/> Fan bearings have been re-lubricated properly.

START-UP

PERFORM THE FOLLOWING STEPS IN ORDER:

Refer to safety standards. Ensure all door latches are secured before starting.

<input type="checkbox"/> 1. With all Electric Power off, all disconnect switches open and fuses removed, check each circuit with an Ohm meter to ground observing no continuity. Reinstall fuses.	<input type="checkbox"/> 8. Immediately check current draw of each leg of each motor.
<input type="checkbox"/> 2. Energize power to the unit disconnect switch.	<input type="checkbox"/> 9. VFD, refer to manufactures start up guide
<input type="checkbox"/> 3. Verify correct voltage, phase and cycles.	<input type="checkbox"/> 10. Check doors and latches for air leaks.
<input type="checkbox"/> 4. Energize fan motor(s) briefly (bump) and check for correct fan rotation.	<input type="checkbox"/> 11. Check for obvious audible leaks.
<input type="checkbox"/> 5. Check operation of dampers. Insure unit will not operate with all dampers closed.	<input type="checkbox"/> 12. Apply steam to cold coils slowly to prevent damage.
<input type="checkbox"/> 6. Energize fan motor(s). Observe fan(s) for smooth operation.	<input type="checkbox"/> 13. Observe energy recovery wheel rotation is correct.
<input type="checkbox"/> 7. Check motor nameplate Full Load Amp rating.	<input type="checkbox"/> 14. Purge on energy recovery wheel is set to specification.

RECORD DATA

POWER SUPPLY: Unit Nameplate V___ PH___ CYC, ___ Verify V ___/___/___

DATA	SUPPLY FAN MOTOR	EXHAUST/RETURN FAN MOTOR
Nameplate	Volts _____ Amps _____	Volts _____ Amps _____
Run Amps	_____ / _____ / _____	_____ / _____ / _____
Catalog Number	_____	_____
Spec Number	_____	_____
Horse Power	_____	_____
RPM	Nameplate _____ Actual _____	Nameplate _____ Actual _____
Frame size	_____	_____
Service Factor	_____	_____
Jump (Skip) Frequencies	_____ / _____ / _____	_____ / _____ / _____

	SUPPLY FAN	EXHAUST/RETURN FAN
Manufacture Name	_____	_____
Type or Model Number	_____	_____
Code or Shop Order Number	_____	_____
Serial Number	_____	_____

	SUPPLY FAN DRIVE KIT	EXHAUST/RETURN FAN DRIVE KIT
Belts (Qty & ID #)	_____	_____
Belt Tension	Tag _____ Actual _____	Tag _____ Actual _____
Fan RPM (DN)	Tag _____ Actual _____	Tag _____ Actual _____

OTHER UTILITIES

Steam Pressure	Heating Coils _____ PSI,	Humidifier _____ PSI
Hot Water Pressure/Temp.	Supply _____ PSI, _____ °F,	Return _____ PSI, _____ °F
Chilled Water Pressure/Temp.	Supply _____ PSI, _____ °F,	Return _____ PSI, _____ °F
Potable Water Pressure	_____ PSI,	Pneumatic Air Pressure _____ PSI

MAINTENANCE

Upon completion of start-up the customer assumes responsibility for periodic maintenance of this equipment in order to continue warranty. Refer to the Installation Operation and Maintenance Manual (Form 102.20-OM1).

Customer's agent signature: _____ **Date:** _____



THIS PAGE INTENTIONALLY LEFT BLANK.

APPENDIX B – LONG-TERM STORAGE

 BY JOHNSON CONTROLS	LONG-TERM STORAGE REQUIREMENT - FIELD PREPARATION AIR HANDLING UNITS	
SERVICE POLICY & PROCEDURES	Supersedes 50.20-NM3 (307)	Form 50.20-NM3 (909)

Failure to comply with these requirements will render any written or implied YORK warranty null and void.

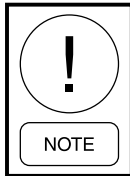

Upon completion of the long term storage period, the warranty commences:

- *Solution - 18 months parts only. (not to exceed 36 months from ship date with delayed start up).*
- *Custom - 18 months factory parts (not to exceed 18 months from ship date).*
- *Labor 12 months only w/ delayed start up.*

I. Supplementary Documentation

The following documentation is required to FULLY COMPLY with the Long-Term Storage requirements.

- A. Long-Term Storage Requirements – GENERAL (refer to Form 50.20-NM1)
- B. Long-Term Storage – PERIODIC CHECKLIST AND LOGS,
 AIR HANDLING UNITS (refer to Form 50.20-CL3).

II. Field Preparation for Long-Term Storage

A. GENERAL

1. Remove and dispose of shipping materials.
2. Perform a visual inspection of the equipment.

Indoor Units

It is Johnson Controls' intention that a shipping wrapper be applied to unpainted indoor units for protection from weather, road dirt, etc. during inland transit and that the wrapper be removed at the time of delivery to allow for a thorough inspection, both inside and out. Visible damage should be noted on the signed and dated bill of lading with a request that the carrier inspect the damage within 72 hrs of notification. The shipping wrapper must

be removed and replaced with a tarp or similar protective covering. Any concealed damaged reported after 15 days will compromise a claim settlement. Inspection requests may be done by telephone or in person, but should be confirmed in writing. If assistance is needed with the claim process, contact your Johnson Controls Sales person.

Outdoor Units

Outdoor units are not fully wrapped. Exposed openings are covered for protection from weather, road dirt, etc. during inland transit. A thorough inspection, both inside and out, should be done at the time of delivery. Visible damage should be noted on the signed and dated bill of lading with a request that the carrier inspect the damage within 72 hrs of notification. Concealed damage must be reported within 15 days of delivery with a request that the carrier inspect the damage within 72 hrs of notification. Any concealed damaged reported after 15 days will compromise a claim settlement. Inspection requests may be done by telephone or in person, but should be confirmed in writing. If assistance is needed with the claim process, contact your Johnson Controls Sales person.

3. Touch up any paint that has worn or chipped off using paint supplied in ship loose items. Prepare the surface as required using a wire brush.
4. Verify that all ship loose items are present. Note any missing items on the Periodic Check List and Log Sheet (50.20-CL3).
5. Locate unit(s) so that passing traffic will not damage shafts, coil connections, damper linkages or unit panels.

6. Refrigerant coils must be evacuated and pre-charged with 5 PSIG nitrogen holding charge. DO NOT damage or disturb these coils and connections.
7. Water coils must have all inlet and outlet connections capped or closed tight to prevent foreign materials and liquids from gaining entrance during the storage period.

B. ELECTRICAL EQUIPMENT AND COMPONENTS (Control Panels, Power Panels, Option Panels, Motors, etc.)

1. Electrical Equipment and Components shall not be stored or left in an outdoor environment.
2. Electrical Equipment and Components shall not be stored or left in a wet or damp environment. Components sealed in plastic shrink-wrap are not exempt from this requirement. Moisture will collect inside the plastic, resulting in corrosion of the cabinet, the electronic components and/or copper bus bars.
3. Cortec® spray (Part VpCL-248) shall be applied to all components in the motor terminal box. The spray shall be applied to all exposed areas of concern.
4. YORK Vapor Emitter(s) shall be installed inside each electrical and electronic components cabinet(s) to protect against corrosion.

Openings in cabinets shall be taped closed to minimize air infiltration during the storage period. The quantity of emitters is determined by measuring the gross volume of the component space occupied. YORK Part Number 026-37705-000 will protect a volume up to 5 cubic feet. YORK Part Number 026-37706-000 will protect a volume up to 11 cubic ft. Both emitters have a service life of 12 months.

5. A Vapor Type Corrosion inhibitor must be installed in the following equipment and components:
 - a. Place one corrosion inhibitor, YORK part number 026-37706-000, inside the power panel.
 - b. Place one corrosion inhibitor, YORK part number 026-37705-000, inside the control panel.
 - c. Place one corrosion inhibitor, YORK part number 026-37705-000, inside each VFD panel.

C. MECHANICAL

1. Spray all exposed shafts and sheaves with anti-corrosion spray, YORK part number 026-37707-007.
2. Disconnect belts and wrap all motors and sheaves in plastic with a YORK vapor emitter, part number 026-37705-000.

 BY JOHNSON CONTROLS	LONG-TERM STORAGE PERIODIC CHECKLIST AND LOGS AIR HANDLING UNITS	
	SERVICE POLICY & PROCEDURES	Supersedes: 50.20-CL3 (507)

Contract No.	_____	Date Delivered	_____
Job Name	_____	Date of Storage Prep.	_____
Serial No	_____	Condition of Unit Delivered	_____
Unit Model No	_____	Explain:	_____
	_____		_____
	_____		_____
	_____		_____

B

**Failure to comply with these requirements will render
 any written or implied Johnson Controls warranty null and void.**

I. Supplementary Documentation

The following documentation is required to FULLY COMPLY with the long term storage requirements.

- A. Long-Term Storage Requirements - GENERAL (refer to Form 50.20-NM1).
- B. Long-Term Storage Requirement - LONG -TERM STORAGE REQUIREMENT FIELD PREPARATION, AIR HANDLING UNITS (refer to Form 50.20-NM3).

II. Checks

1.0 Monthly Checks

- 1.1 Visually inspect Air Handler for damage.
 - 1.1.1 Motors/Drives - The motors and sheaves should be inspected externally for evidence of damage to the protective covering. An inspection is necessary only if it is apparent that the control protection has been disturbed. If this is found, the motor should be re-protected by wrapping and tightly sealing the control with plastic and inserting a desiccant to absorb moisture.
- 1.2 Refrigerant Coils - Check holding charge pressure monthly to be sure that the pressure has not dropped. If pressure has dropped, the unit should be inspected for signs of visible damage which may have caused the loss of pressure. If pressure drops more than 2 psi, the unit should be pressure tested to locate the leak, the leak repaired, and the unit recharged with nitrogen to 5 psig pressure. Note this in the comments section of the monthly log sheet (see page 2 of this document).
- 1.3 Rotate fan shaft several revolutions by hand every month.

FORM 102.20-OM2 (000)

2.0 Quarterly			
	Grease Bearings	Inspect Protective Covering	Comments
Date			
Initial			
Date			
Initial			
Date			
Initial			
Date			
Initial			

4.0 Annual			
	Install New Vapor Emitters	Re-spray Exposed Shafts and Sheaves	Comments
Date			
Initial			

B

The following factors can be used to convert from English to the most common SI Metric values.

TABLE 21 - SI METRIC CONVERSION

MEASUREMENT	MULTIPLY ENGLISH AHU	BY FACTOR	TO OBTAIN METRIC AHU
Capacity	Tons Refrigerant Effect (ton)	3.516	Kilowatts (kW)
Power	Horsepower	0.7457	Kilowatts (kW)
Flow Rate	Gallons / Minute (gpm)	0.0631	Liters / Second (l/s)
Length	Feet (ft)	0.3048	Meters (m)
	Inches (in)	25.4	Millimeters (mm)
Weight	Pounds (lbs)	0.4538	Kilograms (kg)
Velocity	Feet / Second (fps)	0.3048	Meters / Second (m/s)
Pressure Drop	Feet of Water (ft)	2.989	Kilopascals (kPa)
	Pounds / Square Inch (psi)	6.895	Kilopascals (kPa)

TEMPERATURE

To convert degrees Fahrenheit (°F) to degrees Celsius (°C), subtract 32° and multiply by 5/9 or 0.5556.

Example: $(45.0^{\circ}\text{F} - 32^{\circ}) \times 0.5556 = 7.22^{\circ}\text{C}$

To convert a temperature range (i.e., a range of 10°F) from Fahrenheit to Celsius, multiply by 5/9 or 0.5556.

Example: $10.0^{\circ}\text{F range} \times 0.5556 = 5.6^{\circ}\text{C range}$

NOTES



P.O. Box 1592, York, Pennsylvania USA 17405-1592
Copyright © by Johnson Controls 2015
Form 102.20-OM1 (615)
Issue Date: June 1, 2015
New Release

800-861-1001
www.johnsoncontrols.com

Subject to change without notice. Printed in USA
ALL RIGHTS RESERVED