

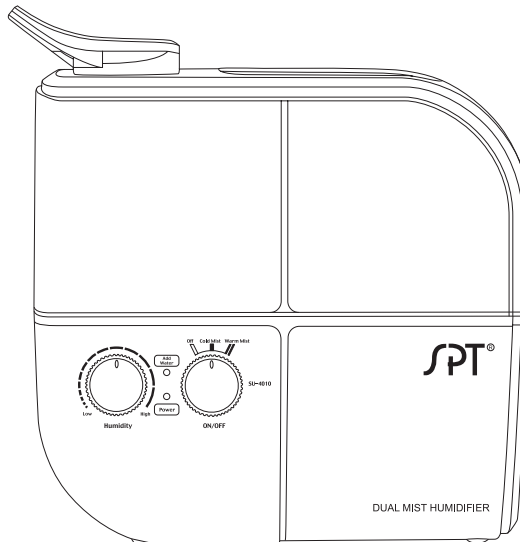

DUAL MIST HUMIDIFIER OWNER'S MANUAL

Model **SU- 4010**
SU- 4010G



NOTE: AFTER READING THIS MANUAL, IF YOU HAVE ANY QUESTIONS OR COMMENTS ON YOUR SUNPENTOWN DUAL MIST HUMIDIFIER, CALL **1-800-330-0388**

NOTE: TO PROLONG THE LIFE OF THIS HUMIDIFIER, THE BEST CHOICE IS TO FILL WITH DISTILLED WATER. FRAGRANCES OR OIL ADDED IN THE WATER WILL CAUSE THE MACHINE TO MALFUNCTION. FRAGRANCES OR OIL ADDED IN THE WATER WILL VOID THE WARRANTY.

(THIS UNIT CANNOT BE USED IN FOREIGN COUNTRIES AS DESIGNED FOR USE IN USA ONLY)

 **SUNPENTOWN INTERNATIONAL INC.**

IMPORTANT SAFETY INSTRUCTIONS

READ AND SAVE THESE SAFETY INSTRUCTIONS BEFORE USING THIS HUMIDIFIER

When using electrical appliances, basic precautions should always be followed to reduce the risk of fire, electric shock, and injury to persons, including the following:

1. Always place this humidifier on a firm, flat and level surface. This humidifier may not work properly on an uneven, non-heat-resistant furniture surface and high magnetic area.

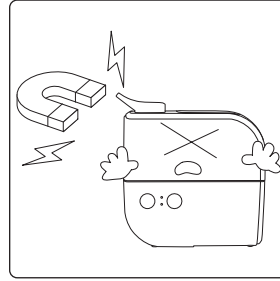
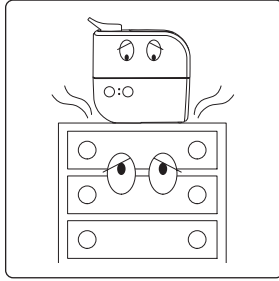
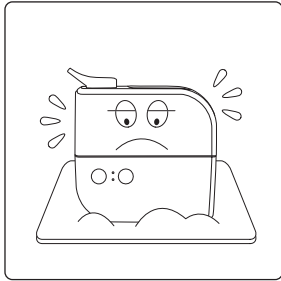

2. Place this humidifier in an area where it is not accessible to children. Don't use it to clean glasses. Don't use without the water tank.

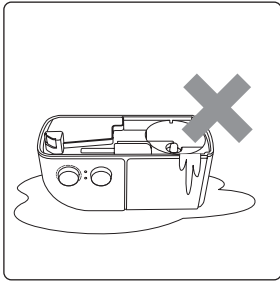
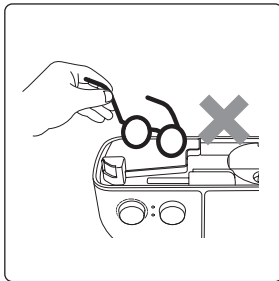
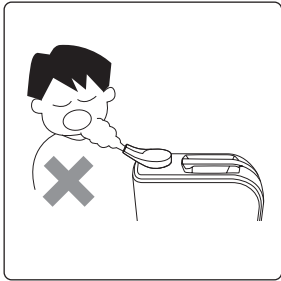

3. Do not place the humidifier near any heat sources such as stoves, radiators, heaters or high moist, freezing areas.

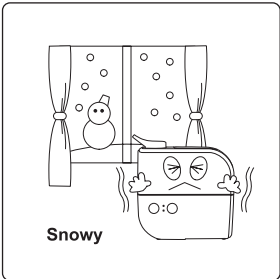
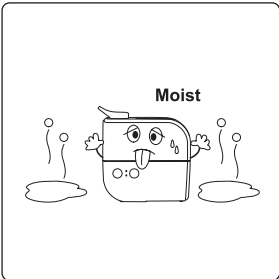
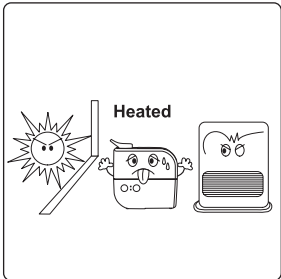

4. Before using the humidifier, check the power cord for any signs of damage. If the cord is found to be damaged, **DO NOT USE** and return the humidifier to the manufacturer under the warranty agreement for repair.

5. This appliance has a polarized plug (one blade is wider than the other). To reduce the risk of shock, this plug is intended to fit only one way in a polarized outlet. If the plug does not fit fully in the outlet, reverse the plug. If it still does not fit, contact a qualified electrician. **DO NOT attempt to defeat this safety feature.**
6. To disconnect the humidifier, first turn controls to the **OFF** position, then grip the plug and pull it from the wall outlet. Never pull the plug by the cord.

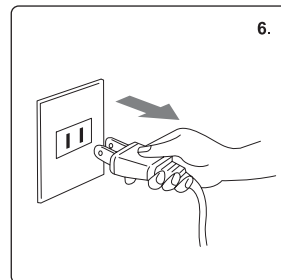
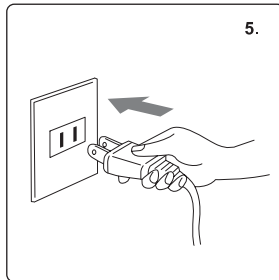

7. A loose fit between the AC outlet (receptacle) and plug may cause overheating and a distortion of the plug. Contact a qualified electrician to replace loose or worn outlet.
8. The humidifier should always be unplugged and emptied when not in operation, while being serviced or cleaned.
9. Never tilt or attempt to move the humidifier while it is operating or filled with water. **UNPLUG** the humidifier before moving.
10. This humidifier requires regular cleaning. Especially for the metal mist-generator plate and water tank.
11. Turn the humidifier **OFF** if the relative humidity exceeds 60%, or if you notice moisture on the inside of your windows. For proper humidity reading use a hygrometer, which is available in many hardware and department stores.
12. **DO NOT** touch the steam vapor. Steam can cause burns.
13. **DO NOT** block the mist grille. This will damage the humidifier.

INTRODUCTION

Thank you for purchasing SPT Warm and Cool mist Humidifier.

HOW DOES IT WORK?

Water passes into the Humidified System where it is vibrated, heated and purified.

The Warm or Cold Moisture system then pulls the air through the top nozzles and spreads invisible moisture-balanced air into the room.

MODEL SU-4010 SU-4010G :

Your humidifier is made up of these parts:

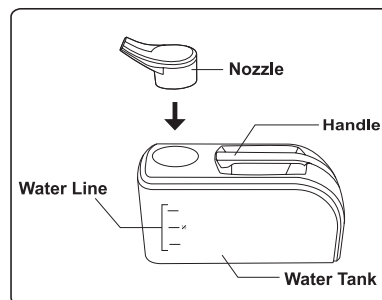
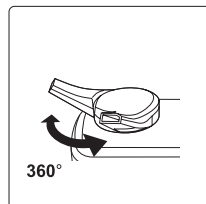

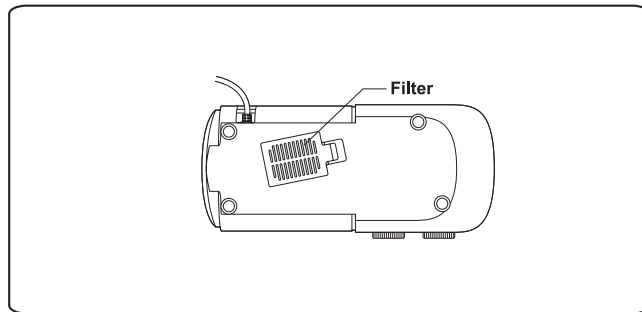
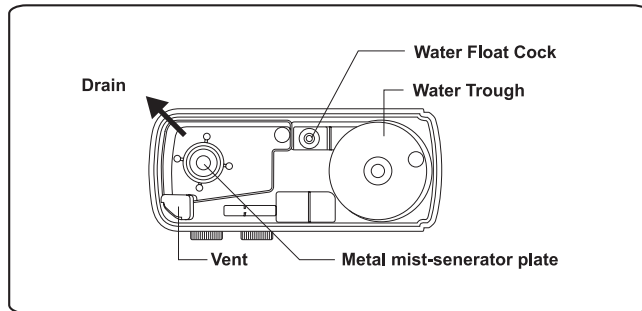
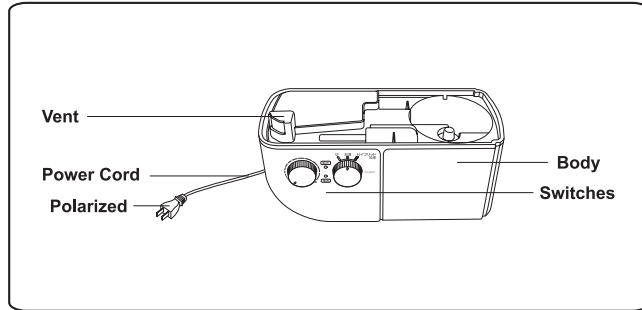
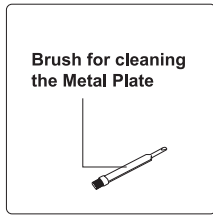
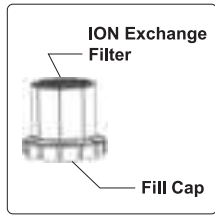

SETUP

- Select a firm, level, and flat location - at least six inches (15 cm) from any wall for proper airflow.
Place the humidifier on a water-resistant surface, as water can damage furniture and some flooring.

FILLING

- Remove the water tank by grasping the handle and pull it straight up. Set aside (Fig. 1).

NOTE: WHEN CARRYING THE FILLED WATER TANK, PLEASE USE THE HANDLE AND PLACE YOUR OTHER HAND UNDER THE TANK FOR ADDITIONAL SUPPORT.

- Remove the nozzle and pull it straight up. Set aside (Fig. 2)
 - Turn the Water Tank upside down so that the Fill Cap is facing up; unscrew the Fill Cap and ION Exchange Filter by turning it counter-clockwise and set aside.
Fill the Water Tank with **COOL** tap water (Fig. 3). **Distilled water** is recommended. **DO NOT USE HOT WATER.** Doing so may damage the humidifier.
 - Replace the fill cap and ION Exchange Filter by turning it clockwise and don't forget the washer (Fig. 4). **DO NOT OVER TIGHTEN.**
 - Turn the Water Tank right side up. Position the Nozzle and Water Tank into the humidifier and push it into place (Fig. 5).
 - Some water will flow into the Removable Tray when the filled tank is properly in place.
 - Once the filled tank has been positioned, do not attempt to move the humidifier. If it has to be moved, unplug the humidifier and remove the water tank first.
- CAUTION: DO NOT POUR WATER INTO THE NOZZLE HOLE ON TOP OF THE HUMIDIFIER (Fig. 2). DOING SO MAY DAMAGE THE HUMIDIFIER OR CAUSE PERSONAL INJURY.**

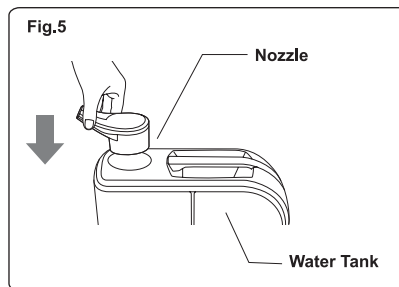
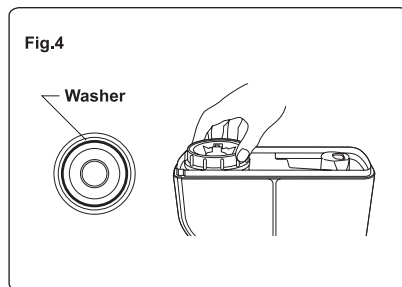
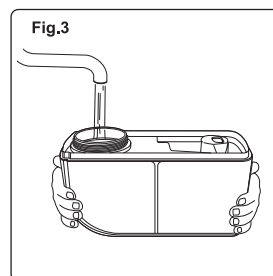
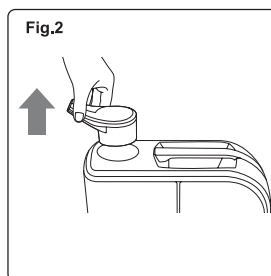
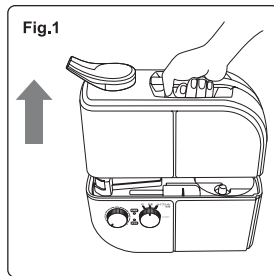

OPERATION

POWER

CAUTION: DO NOT PLUG IN THE HUMIDIFIER WITH WET HANDS AS AN ELECTRICAL SHOCK COULD OCCUR.

• Plug the filled humidifier into a polarized 120V outlet. **DO NOT FORCE THE POLARIZED PLUG INTO THE OUTLET;** it will only fit one way.

HUMIDITY CONTROL KNOB

1. Set the Humidity Knob to the desired position (Fig. 6).
HIGH: For fast humidifying.
LOW: For more gradual humidification.

NOTE: You will not hear a difference when turning the humidifier from High to Low.

HUMIDIFIER POWER ON/OFF KNOB

1. TURN ON the Humidifier Power Knob to the desired position (Fig. 7).
Off: Power Off.
Cold Mist: Allow 5-10 minutes for the humidifier to begin producing Cold moisture.
Warm Mist: Allow 5-10 minutes for the humidifier to begin producing Warm moisture.
2. Indicator LED
Add Water: **Red** LED.
Power ON: **Green** LED.

REPLACEMENT INSTRUCTION

1. Remove the old Ion Exchange Filter from the Fill Cap by turning counter-clockwise (Fig.6-1).
2. Set the new Ion Exchange Filter onto the fill cap and turn clockwise to secure (Fig. 6-1).

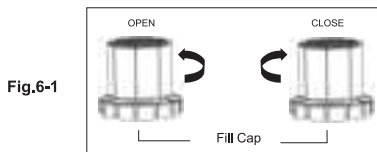
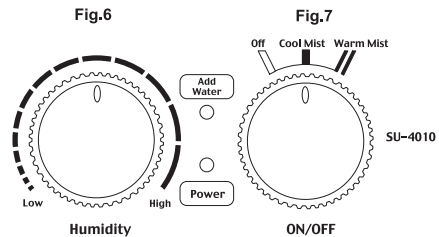

Fig.6-1



NOTE: It's recommended to replace this water filter (Ion Exchange Filter) once every 6 months, based on 6 hours of use per day, with humidity set in the middle.

WEEKLY CLEANING

We recommend cleaning the humidifier weekly.

- First, turn off and unplug the humidifier. Wait at least 10 minutes for the unit to cool.
- Remove the water tank by grasping the handle and pull it straight up. Set aside (Fig. 1).
- Clean the Water Trough (Fig. 8).
- Clean the Water Float Cock (Fig. 9).

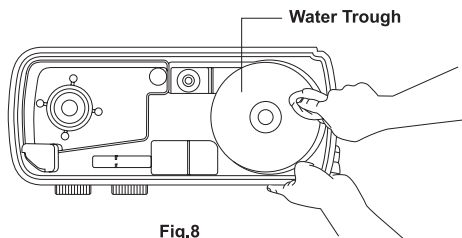

Fig.8

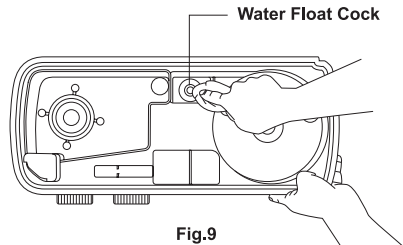

Fig.9

NOTE: Empty any water from the Base and Removable Tray.

NOTE: THE USE OF OTHER WATER TREATMENT PRODUCTS, CHEMICALS, SOAPS, DETERGENTS OR ABRASIVE CLEANSERS NOT RECOMMENDED IN THE MANUAL MAY CAUSE DAMAGE TO THE HUMIDIFIER OR AFFECT PERFORMANCE.

CLEANING THE METAL MIST GENERATOR PLATE

If the unit stops producing mist, even while there is water in the tank, the mineral build-up may need to be removed from the Mist Generator (Vibration Unit) of the Power Unit.

- Remove the water tank by grasping the handle and pull it straight up. Set aside (Fig. 1).
- Use the attached brush or a soft, dry cloth to wipe the outer surfaces of the Metal Mist Generator Plate (Fig. 10). Some deposit may remain, but should not interfere with the operation of the unit.

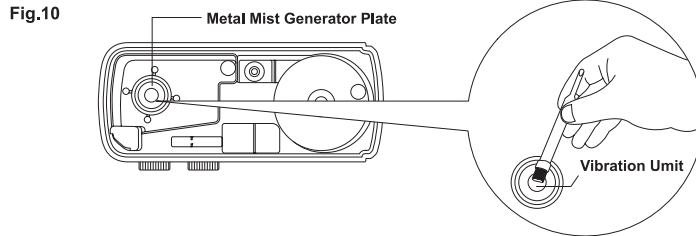

NOTE: How often you should perform this special maintenance depends upon the hardness of the water you are using and how quickly mineral deposits form on the interior surfaces of the humidifier. **DO NOT** clean the Mist Generator under running water. Doing so may cause damage or personal injury.

CLEANING THE INLET GRILLE FILTER

- Remove the filter by pushing the Inlet Grille Filter notch. Set aside (Fig. 11).
- Lift up the filter to remove it from humidifier.
- Use the vacuum cleaner to clean it.
- Wash the filter using warm, soapy water.
- Use paper towels to wipe off any excess water on the filter.

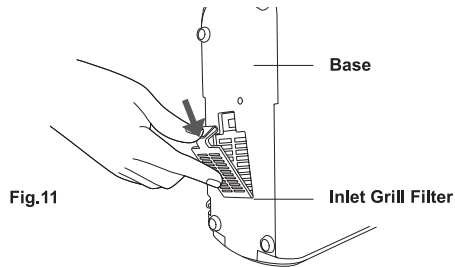

TROUBLESHOOTING

PROBLEM

Unit will not start when Knob is ON.

SOLUTION

1. Check to be sure that the power cord is plugged into a 120V, AC outlet.
2. Check the electrical outlet by plugging in a working appliance.
3. Unplug the unit. Remove and reassemble the water tank to make sure it is properly fitted.

END-OF-THE-SEASON CARE AND STORAGE

- Follow **WEEKLY CLEANING** instructions when the humidifier will not be used for at least one week or more, or at the end of the season.
- Dry the humidifier completely before storing. **DO NOT** store it with water inside the Removable Tray, Base, or Water Tank.
- Pack the unit in its original carton and store in a cool, dry location.
- Before next use, remember to clean the humidifier.

TECHNICAL SPECIFICATIONS

Model	SU-4010	SU-4010G
Color	Blue	Green
Width	13.18in	
Depth	5.31in	
Height	12.40in	
Weight	7.50lbs	
Input Voltage	120 volts AC, 60Hz	

CUSTOMER ASSISTANCE LINE

If you experience a problem, please see the warranty for information. Please **DO NOT** attempt to repair this unit yourself. Doing so, will void your warranty and could cause damage to the fan or personal injury to yourself. If you have any questions concerning this appliance, please call: **1-800-330-0388**

YOUR GUARANTEE

If this product is found to be faulty as a result of faulty materials or workmanship within 1 year from date of purchase, it will be repaired or replaced free of charge. This guarantee is subject to the following terms:

1. Sunpentown must be notified of the fault.
2. Proof of purchase must be presented to Sunpentown's nominated representative.
3. The warranty will be voided if the product is modified, misused or repaired by an unauthorized person.
4. The guarantee after repair or replacement will not be extended beyond the original one-year period.
5. All replacement parts or units will be new or reconditioned.
6. Parts or units, which are replaced, become the property of Sunpentown.
7. The warranty applies for the use of the product in the USA.
8. Warranty does not include freight charges.

This **GUARANTEE** is in addition to your Statutory Rights. Please keep this warranty for your record. **DO NOT** return it.