

SIEMENS



Installation Manual

SENTRON 3/6 Bus Plug with Optional SEM3™ Package

usa.siemens.com/busway

	<h2 style="text-align: center; background-color: #0056b3; color: white; padding: 5px;">NOTICE</h2> <p>The SEM3™ metering system offers a range of hardware options that affect input ratings. Use only parts and assemblies that are made specifically for use with the SEM3™ system. Failure to do so could permanently damage the meter. This document provides installation instructions applicable to each hardware option.</p>
---	---

SEM3™ (Siemens Embedded Micro Metering Module) Certifications

The unauthorized repair of equipment, or tampering by unqualified personnel, will result in dangerous conditions that can cause death, serious injury or property damage.

IMPORTANT

Information contained herein is general and NOT intended for specific application purposes. The user is responsible for application, installation, operation and maintenance of the equipment purchased. Siemens reserves the right to make changes at any time without notice or obligation. Should a conflict arise between the general information contained in this publication and the contents of drawings or supplementary material or both, the latter shall take precedence.

SUMMARY

These instructions do NOT purport to cover all details or variations in equipment, nor to provide for every possible contingency to be met in connection with installation, operation or maintenance. Should further information be desired or problems arise which are not covered contact the local sales office.

THE CONTENTS OF THIS INSTRUCTION MANUAL SHALL NOT BECOME PART OF OR MODIFY ANY PRIOR OR EXISTING AGREEMENT, COMMITMENT OR RELATIONSHIP. THE SALES CONTRACT CONTAINS ALL OBLIGATIONS OF SIEMENS INDUSTRY, INC. THE WARRANTY CONTAINED IN THE CONTRACT BETWEEN THE PARTIES IS THE SOLE WARRANTY OF SIEMENS INDUSTRY, INC. ANY STATEMENT CONTAINED HEREIN DOES NOT CREATE NEW WARRANTIES OR MODIFY THE EXISTING WARRANTIES.

Standards Compliance for the SEM3™ Product

Approvals and Certifications



- **Accuracy**
 - ANSI C12.1
 - ANSI C12.20/0.2
- **Safety and Construction**
 - CSA C22.2 No. 1010-1 Safety Requirements for Electrical Equipment for Measurement
 - UL 916 Energy Management Equipment
 - UL61010-1 (IEC 61010-1) Test and Measurement Equipment
- **Electromagnetic Compatibility**
 - IEC 61000-4-2 Electrostatic Discharge (B)
 - IEC 61000-4-3 Radiated Immunity (A)
 - IEC 61000-4-4 Electric Fast Transient
 - IEC 61000-4-5 Surge Immunity (B)
 - IEC 61000-4-6 Conducted Immunity
 - FCC Part 15 Subpart B, Class A Digital Device, Radiated Emissions
- **Environmental Conditions**
 - Altitude up to 3000 meters
- **Siemens SENTRON Busway Certifications**
 - UL 857
 - NEMA BU1
 - CSA C22.2
 - IEC 439-1 (1993), IEC 439-2 (1993) and IEC 529 (1989)
 - BS EN 60529, BS EN 60439-1 and BE EN 60439-2
 - UL 1479
 - DIN 4102 Parts 9 and 12
 - BS 6387 Parts 11.1 and 11.2

	<h2 style="text-align: center; background-color: #0056b3; color: white; padding: 5px;">⚠ DANGER</h2> <ul style="list-style-type: none"> • Hazardous voltages and exposed electrical conductors will cause death, serious injury, or property damage. • De-energize before working inside busway system. Only qualified personnel should work on or around this equipment after becoming thoroughly familiar with all warnings, safety notices, and maintenance procedures contained herein. 	
---	---	---

Table of Contents

1.0 Definitions	2
1.1 Qualified Personnel	2
1.2 Danger	2
1.3 Warning	2
1.4 Caution	2
1.5 Tip	2
2.0 References	2
3.0 Storage Instructions	2
4.0 Preparing for Installation	2
5.0 Basics of SEM3™	2
5.1 Energy Management System	3
5.2 SEM3 Features	3
6.0 Installation & Removal	3
6.1 Installation Conditions	3-4
6.2 SEM3™ FCC Notice	4
6.3 Control Wiring	4-6
6.4 Other SEM3™ Components	6-8
7.0 Configuring the Metering System	8-9
7.1 Assign Static IP Address	9-10
7.2 Web User Interface	10
7.3 Addressing the Meter Racks	10-11
8.0 Sample Network Topology	12
9.0 Additions to the Network	13
10.0 Contact Information and Support	13
11.0 Notes	14-17

This document makes frequent reference to both the Storage, Installation and Maintenance Instructions for SENTRON Busway Systems and the SEM3™ – Embedded Micro Metering Module™ User Guide.

1.0 DEFINITIONS

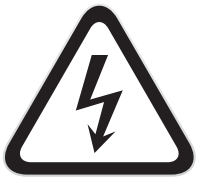
1.1 QUALIFIED PERSONNEL

FOR THE PURPOSE OF THIS MANUAL AND PRODUCT LABELS, A QUALIFIED PERSON IS ONE WHO IS FAMILIAR WITH THE INSTALLATION, CONSTRUCTION AND OPERATION OF THE EQUIPMENT AND THE HAZARD INVOLVED. IN ADDITION, HE OR SHE HAS THE FOLLOWING QUALIFICATIONS:

- Is trained and authorized to energize, de-energize, clear, ground and tag circuits and equipment in accordance with established industry safety procedures.
- Is trained in the proper care and use of protective equipment such as rubber gloves, hard hat, safety glasses or face shields, flash clothing, etc., in accordance with established industry safety practices.
- Is trained in rendering first aid.

1.2 DANGER

FOR THE PURPOSE OF THIS MANUAL AND PRODUCT LABELS, **DANGER** INDICATES AN IMMINENTLY HAZARDOUS SITUATION WHICH, IF NOT AVOIDED, WILL RESULT IN DEATH OR SERIOUS INJURY.

1.3 WARNING

FOR THE PURPOSE OF THIS MANUAL AND PRODUCT LABELS, **WARNING** INDICATES A POTENTIALLY HAZARDOUS SITUATION WHICH, IF NOT AVOIDED, COULD RESULT IN DEATH OR SERIOUS INJURY.

1.4 CAUTION

FOR THE PURPOSE OF THIS MANUAL AND PRODUCT LABELS, **CAUTION** INDICATES A POTENTIALLY HAZARDOUS SITUATION WHICH, IF NOT AVOIDED, MAY RESULT IN MINOR OR MODERATE INJURY.

1.5 TIP

FOR THE PURPOSE OF THIS MANUAL AND PRODUCT LABELS, **TIP** INDICATES A PRACTICE, TECHNIQUE OR AWARENESS THAT MAY EASE INSTALLATION.

2.0 REFERENCES

This instructional document makes references to multiple existing documents and websites:

SEM3™ Website: www.usa.siemens.com/SEM3

Siemens Busway Website: www.usa.siemens.com/busway

SEM3™ User Manual: http://w3.usa.siemens.com/us/internet-dms/btlv/PowerDistributionComm/PowerDistribution/docs_EABU%20docs/SIE_MA_SEM3UserManual.pdf

Energy Management Software:

<http://w3.usa.siemens.com/powerdistribution/us/en/product-portfolio/power-monitoring/energy-management-software/Pages/energy-management-software.aspx>

3.0 STORAGE INSTRUCTIONS

Upon receipt, immediately inspect busway components for possible concealed damage from shipping and/or handling. If damage has occurred, file a claim with the carrier. If there is no damage, restore the packaging to its original condition to prepare for job site storage. Store busway indoors in a clean and dry area with uniform temperature to minimize condensation. Protect against mechanical damage and exposure to lime dust (concrete), water, corrosive fumes or liquids and salts.

Failure to properly store and protect the busway can cause damage and will void the warranty.

4.0 PREPARING FOR INSTALLATION

Deliver busway to installation location prior to unpacking. Shipping crates/cartons display exterior identification of the packaged busway components. Each busway component is further identified by an item number located on the nameplate, which corresponds to the item number on the busway installation drawing(s).

Inspect each busway component for possible damage. Consult the factory if damage is found. Confirm that the contact surfaces are not damaged and are clean and dry. Abrasives should NOT be used on these surfaces because contact surfaces are electroplated. Inspect joint insulators for cracking or any sign of damage.

5.0 BASICS OF SEM3™

The SEM3™ (Siemens Embedded Micro Metering Module) system is designed to measure the current, voltage, and energy consumption of up to 45 circuits.

The SEM3™ consists of a controller, racks, cables, meter modules and current transformers (CTs) that can be tailored to a specific application, in this case a bus plug. Each CT is terminated into a meter module that in turn is mounted in a rack. The racks get power from and communicate back to the controller through product specific communications cables that are part of the SEM3™ product line.

The SEM3™ integrated bus plug is preconfigured to communicate via Modbus TCP through an Ethernet port on the exterior of the controller plug to outside systems. Real-time values may be viewed on the controller web pages. If Modbus RTU is required for your application, please contact Siemens Customer Service, (see Section 10.0).

The controller web interface is used to configure the SEM3™ system to the application. System info, CT ratio setting and alarms as well as configuring the meter modules into 1, 2, or 3 pole meters are all accomplished through embedded and easy to use web pages.

Reference SEM3™ Website link Section 2.0.

5.1 ENERGY MANAGEMENT SYSTEM

You can use SEM3™ meters as standalone devices, but their extensive capabilities are fully realized when integrated with WinPM.net software as part of an enterprise energy management (EEM) system.

EEM systems give energy consumers the tools to meet all the challenges and opportunities of the new energy environment. EEM systems use real-time information to directly address a broad range of requirements throughout the power delivery chain and across an entire enterprise. These systems offer an integrated solution to managing distributed generation, energy purchasing, energy cost control, operations and efficiency.

Applications that include SEM3™ typically require additional equipment. Display & analysis software tools are almost always used to manage, interpret and distribute the data measured by a meter. There are usually a variety of tools used, and often these tools are connected using different communications standards and protocols.

Reference [Energy Management Software](#) link, Section 2.0.

5.2 The SEM3™ meters

The SEM3™ meters provide all common active, reactive and apparent energy parameters: kWh, kVARh and kVAh, respectively.

Energy registers can be logged automatically on a programmed schedule by a supervisory system such as WinPM.Net. Reference [Energy Management Software](#) link Section 2.0.

All energy parameters represent the total for all three phases. Energy readings are true RMS. Beyond this value, readings roll over to zero (0).

SEM3™ meter modules provide real-time values, including true RMS per phase and total for:

- Voltage and current
- Active power (kW) and reactive power (kVAR)
- Apparent power (kVA)
- Power factor and frequency

6.0 BUS PLUG INSTALLATION AND REMOVAL

Refer to the [Storage, Installation and Maintenance Instructions for SENTRON Busway Systems](#) (Section 11.7) for installation and removal procedure of the SENTRON 3/6 Bus Plug. If possible, de-energize the busway when installing this product. Ensure all breakers are in the **OFF** position when installing and removing bus plugs.

Metered bus plugs are designed for connection to a controller bus plug to create a metering network. Each controller is designed to manage data from a maximum of 45 meter modules. It is recommended to position metered bus plugs near the network controller bus plug to limit the length of control wiring and the number of connection points in each network.

Bus plugs should be installed on the busway prior to connecting network control wiring. Limits on control wiring length are noted in Section 6.3.

TIP: It is suggested to determine the network layout and meter module address plan PRIOR to installing bus plugs on the busway. A meter module configuration label (Figure 1) is provided on the cover of each bus plug for recording network and addressing information. Additionally, a plexiglass view port covers all meter modules allowing for the user to view meter module phasing and rack addressing. This view port also allows racks to be re-addressed without opening the front cover of the bus plug. See Section 7.3 for meter addressing.

TIP: Depending upon amperage, voltage and length requirements, the drop cords from the bus plugs may be difficult to maneuver. During installation of plugs it is suggested to keep any wire management devices in place from shipment. Only remove this wire management device when the plug is installed on the busway and the receptacle is required to be plugged into a downstream load. Additional measures may be required to compensate for added weight of the plugs due to these cords.

For busway maintenance procedures please see section 12 of the [Storage, Installation and Maintenance Instructions for SENTRON Busway Systems](#) manual.

6.1 INSTALLATION CONDITIONS

Ambient temperature may range from 32°F to 104°F (0°C to 40°C) due to the use of thermal trip breakers in many applications.

Mains supply allow voltage fluctuations of 10% less than nominal low range and 10% more than nominal high range.

SEM3™ is Measurement Category IV (CAT IV). CAT IV may be used for utility level measurements on primary over-current devices. Energy is limited by circuit breakers to less than 110 kVA, with the current not exceeding 11 kA.

Installation and maintenance of the SEM3™ metering system should only be performed by qualified, competent personnel that have appropriate training and experience with high voltage and current devices.

DANGER: Do not use digital output devices for primary protection functions. These include applications where the devices perform energy limiting functions or provide protection of people from injury. Do not use the SEM3™ in situations where failure of the devices can cause injury or death, or cause sufficient energy to be released such that the equipment is a fire hazard. The meter can be used for energy management functions.

6.2 SEM3™ FCC Notice

This equipment has been tested and found to comply with the limits for a Class A and Class B digital device 240V and below and 480V and below respectively, pursuant to Part 15 of the FCC Rules. These limits are designed to provide reasonable protection against harmful interference when the equipment is operated in a commercial environment. This equipment generates, uses and can radiate radio frequency energy and, if not installed and used in accordance with the instruction manual, may cause harmful interference to radio communications. Operation of this equipment in a residential area is likely to cause harmful interference in which case the user will be required to correct the interference at his or her own expense.

6.3 CONTROL WIRING

Once the bus plugs are installed on the duct, the control wiring may be configured. Two types of control wires are used:

- 1) 600V Class 2 cables or 2) CAT6 Ethernet cables.

1) **600V Isolated Communication cables** are used to "daisy chain" metered bus plugs (not containing the SEM3™ controller) back to a central controller bus plug. The cables are used for two-way communication from the controller to the rack/meter module. Communication cables should only be installed after the bus plugs are installed on the busway.

CAUTION: It is recommended to de-energize the SENTRON busway when installing the communication cables for the metered bus plugs. This limits hazards associated with working near live electrical conductors.

Communication cables are Class 2 shielded cables (Figure 2) and are suitable for use in 600V applications. Care should be taken to follow codes and standards for clearance and isolation of Class 2 wiring from power wiring. These are **NOT** standard Ethernet cables.

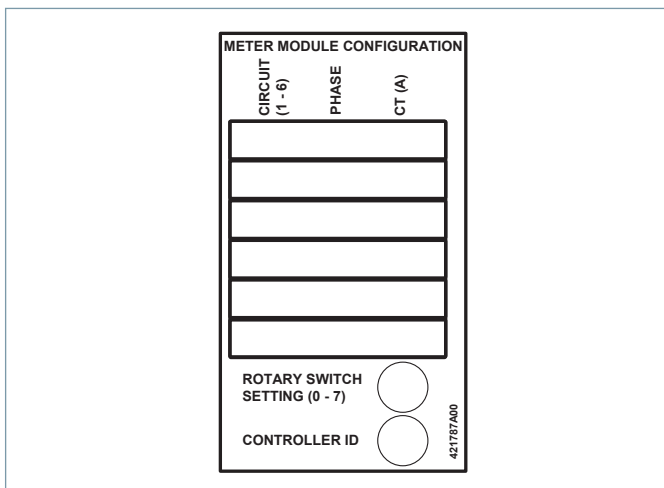

Figure 1: Meter Module Configuration Label



Figure 2: 600V Isolated Communication Cables

CAUTION: Failure to use SEM3™ components from Siemens could cause damage to the product and place the user at risk of electrical shock or fire.

Figure 3 shows the RJ45 communications ports on the rear of a metered bus plug. Similarly, controller bus plugs have two RJ45 communication ports labeled R1 and R2 on the rear side of the controller housing. A "daisy chain" metering network is formed by connecting communication cables between the meter plug ports and controller ports R1 and R2. Each controller bus plug can support a maximum of 45 meter modules split between ports R1 and R2. Note that controller plugs have up to six meter modules which must be included when calculating the total number of meter modules in the network. Please refer to Section 8.0 for an illustration of a typical network topology. Communication cables are available in 6, 12, 24, 36, 60, 120 and 240 inch lengths.

Communication cable length for any network should be limited as listed below:

- Total communication cable length from controller to end of "daisy chained" run, metering 24 poles, **NOT TO EXCEED 60 FEET.**
- Total communication cable length, metering 18 poles, **NOT TO EXCEED 100 FEET.**
- Total communication cable length, metering fewer than 18 poles, **NOT TO EXCEED 200 FEET.**

TIP: Minimizing the total length of communication cable in a network will promote efficient communication between the controller & meter modules. Metering accuracy is unaffected by overall cable length.

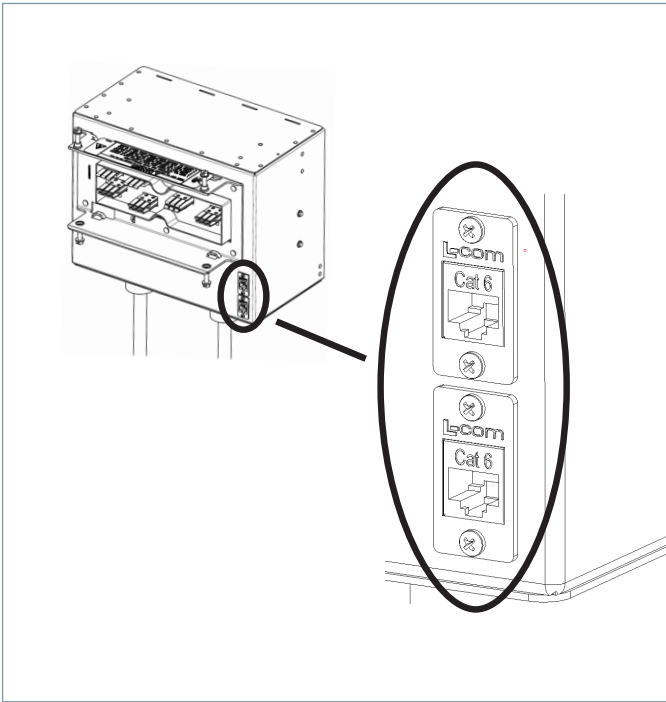

Figure 3: Metered Plug with Input and Output Ports

Communication cables between meter plugs may be connected in a "daisy chain" fashion using either RJ45 port shown in Figure 3. There is no specific "input" or "output" functionality to these ports on the metered plugs. However, setting the rotary dial to the proper setting is required as described in Section 7.3. Connection of "daisy chained" meter plugs to the controller plug shown in Figure 4 is described next.

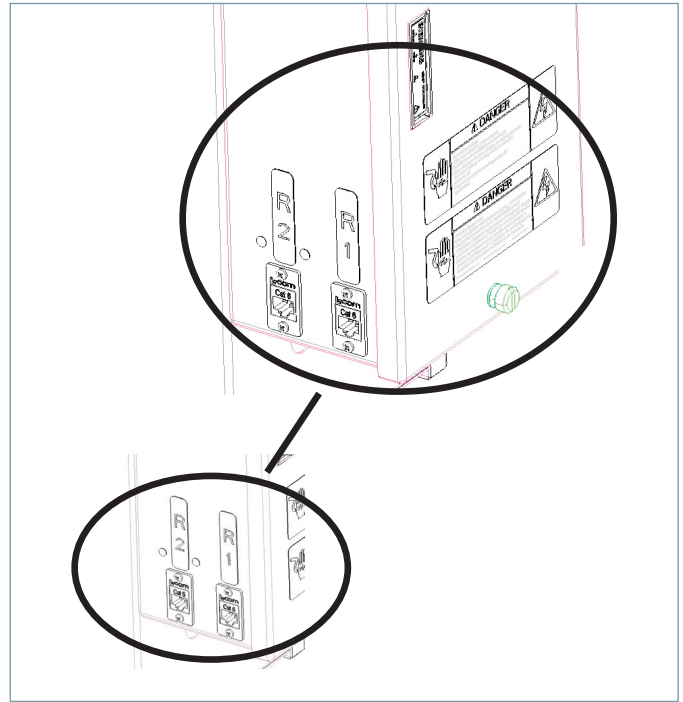

Figure 4: Controller Plug with Input and Output Ports

The SEM3™ controller plug (Figure 4) provides power to and manages data from the SEM3™ metered bus plug network. This plug is designed to accept input from a network containing TWO sets of "daisy chained" metered bus plugs using ports R1 and R2 as shown. It is generally recommended to position the controller plug at the center of the metered plug network. Communication cables connected to ports R1 and R2 are required to transmit power and information between the "daisy chained" meter plugs and the controller plug.

Note: The controller plug is factory constructed with internal metering; these meters are included in the R1 branch. The controller in this bus plug will aggregate inputs from metered plugs and output data via the Ethernet port marked PC on the front of the bus plug. 10/100BASE-T port with an RJ45 modular connector). The Ethernet port is capable of data rates up to 100Mbps.

TIP: It is generally recommended to balance the number of meter modules connected to ports **R1** and **R2** on the controller bus plugs.

Note: Cable management is highly recommended to avoid damage or accidental disconnection of communication cables. Siemens offers a cable management system to best protect communication cable wiring. This system has catalog number BPSCMK12 and may be routed on any flat surface or the busway per user preference. This kit consists of 12 24-inch spines.

2) CAT6 Ethernet cables are required to transmit data from the SEM3™ controller to an upstream data management system. The port labeled PC shown in Figure 5 is the data output port and should be used for connecting to upstream data management systems. Multiple CAT6 cables may be connected via an Ethernet switch shown in Figure 5 below (sold separately).



Figure 5: SIEMENS Scalance 8-Port Ethernet Switch

The output of this Ethernet switch may then be routed back to a centralized building management system via CAT6 cable. Details on this and other network topologies are described in Section 8.0.

6.4 OTHER SEM3™ COMPONENTS

- 1) **Current Transformers (CTs) for use** in the SEM3™ system are 100 mA output and are self protecting/shorting. CTs are factory installed in the bus plug. **Any modification of factory wiring will void the warranty.** More information on Current Transformers may be found in the **SEM3™ User Manual** found at www.usa.siemens.com/SEM3
- 2) **Meter Modules** are single phase meters that collect energy information via a SEM3™ CT. Meter modules are available in either high (0.2%) or low accuracy (1%) versions. The meter module snaps into a SEM3™ rack assembly, producing an audible click when locked into position. The Meter Rack provides a hard coded address for each meter module. Two and three phase circuits require meter modules to be installed contiguously in the rack. Gaps between modules prevent multi-pole circuit output. Each module must have the phase

switch on the top of the module set to the phase that the CT is metering. Phase A, B or C (Line 1, 2 or 3 respectively). SEM3™ bus plugs, unless field-wired, are factory configured with meter modules installed and circuit switches pre-set. Additionally, a meter module configuration label is provided on the bus plug cover showing phasing & circuit information, see Section 7.3.

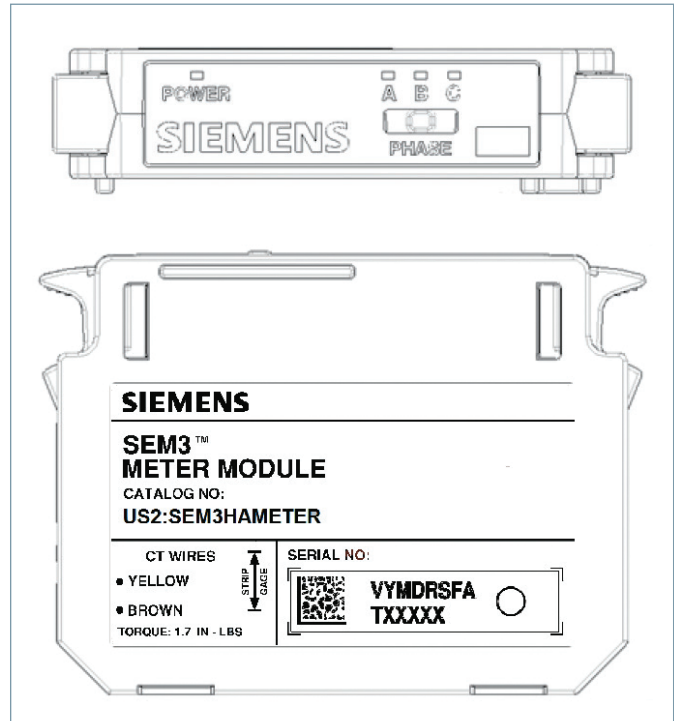

Figure 6: SEM3™ Meter Module

Note: Once the meter module is placed into the meter rack and energized, the phase position will be indicated by a different color LED for each position. Colors are orange for phase A (line 1), yellow for phase B (line 2), green for phase C (line 3). LED'S are adjacent to the phase numbers. The power indication LED also indicates communications by flashing. CT sizing for each meter module will be done through the controller web page configuration.

- 3) **Meter Racks** have the addresses for the module to controller communications hard coded into them. Three and six meter racks are available in the SENTRON 3/6 Bus Plug. The three and six module racks have a rotary switch to allow them to be configured for multiple address ranges. See section 7.3 for directions on addressing the racks and modules.
- 4) The **Controller** functions as the set up interface for the system. System settings, CT ratios, PT ratios, alarm settings, communications settings and passwords are all set using the web page interface of the controller. See Section 7.1 for directions on configuring the SEM3™ controller.

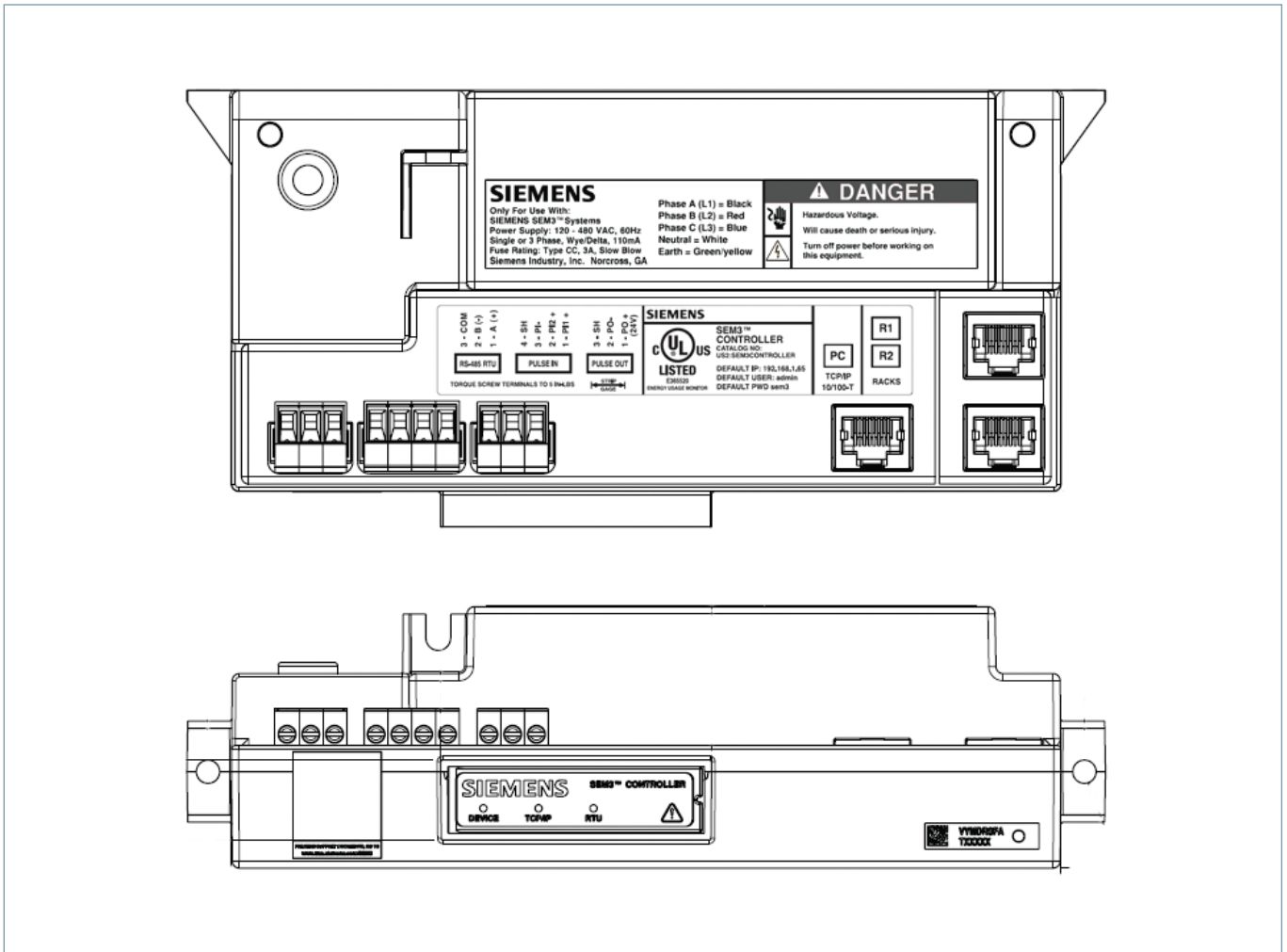

Figure 7: SEM3™ Controller

The control module houses the controller for the bus plug application, shown in figure 8. The control module also contains a fused switch that controls power to the SEM3™ controller. This switch is shipped in the **ON** position, meaning the SEM3™ will turn on when the plug is installed and the busway is powered. The fusible switch may be used to turn off the controller. Control power for the SEM3™ is tapped off the bus on the line side of the breakers, so metering continues even when the breakers are in the **OFF** position.

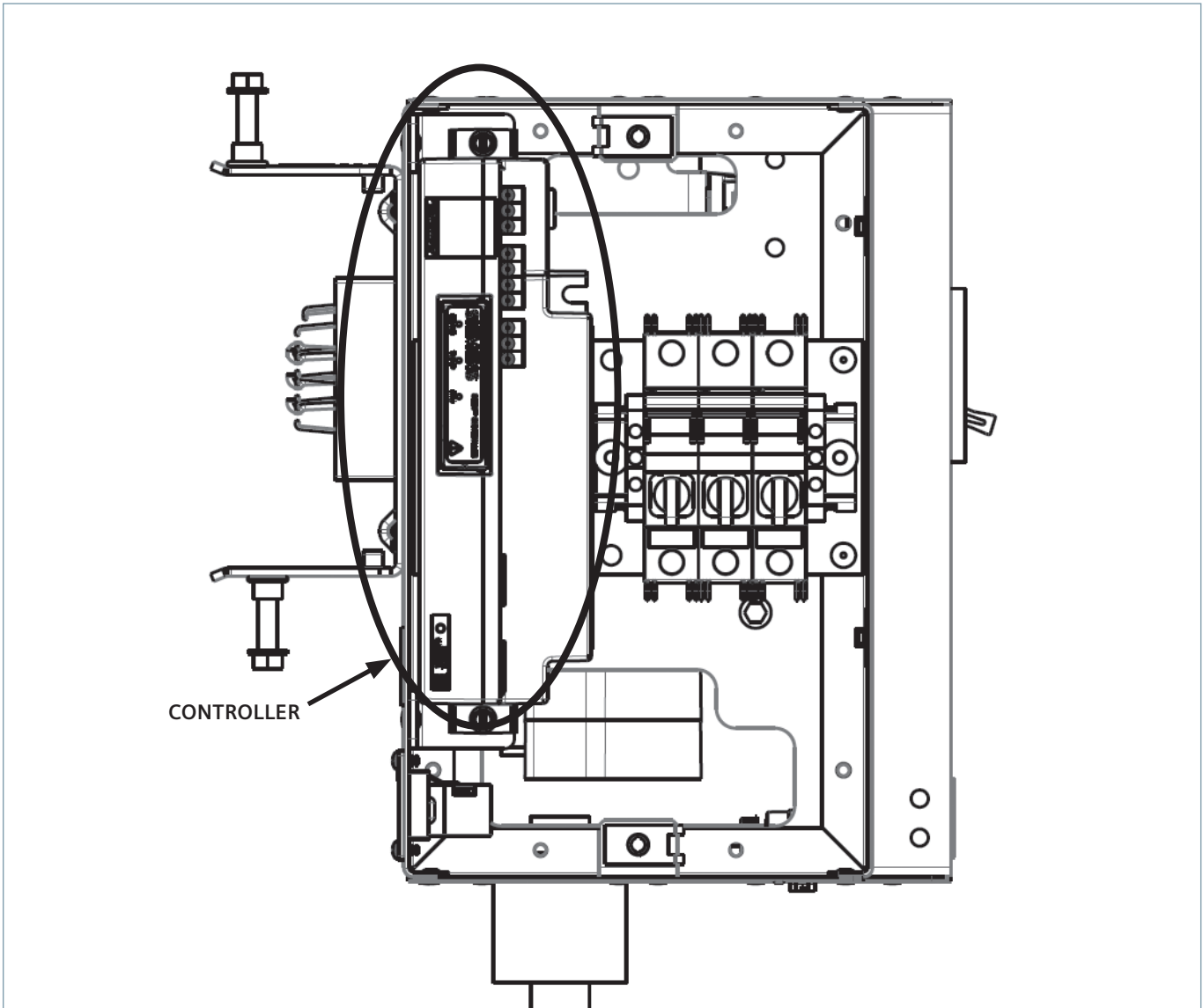

Figure 8: Control Module on Controller Bus Plug

7.0 CONFIGURING THE METERING SYSTEM

To start: Connect the controller to a PC using the Ethernet / Modbus TCP port. The port labeled **PC** is located on the front surface of the control module as shown in Figure 9. Connection to this port requires a CAT6 cable. This **PC** port may alternately be connected to an Ethernet switch to consolidate multiple ontrroller outputs.

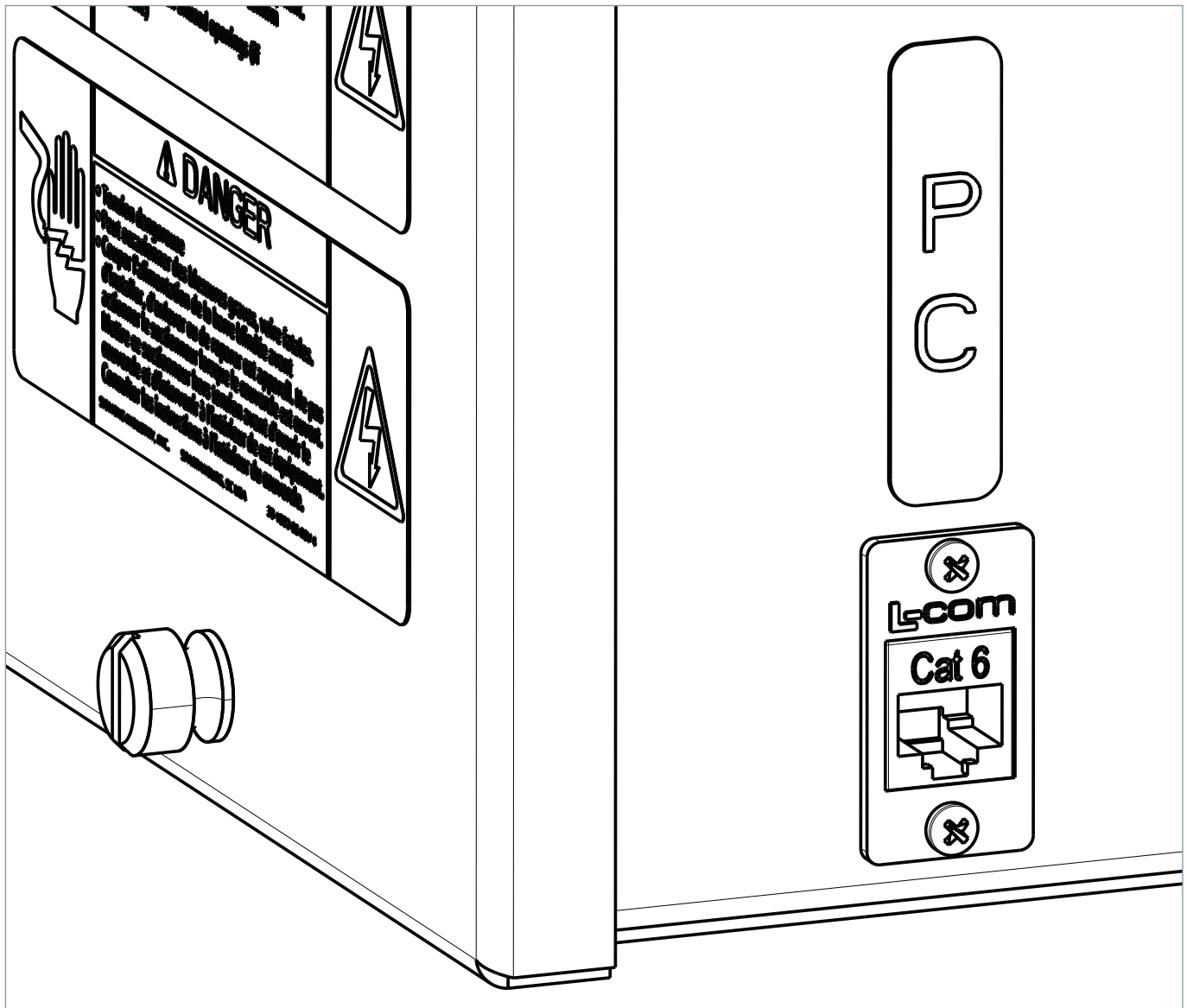

Figure 9: PC Output Port on Control Module

TIP: An Ethernet switch may be used to collect output from multiple controllers. Aggregated data can then be sent to an upstream data management system via a CAT6 cable from the Ethernet switch. Please see Section 8.0 for a description of this network topology.

7.1 ASSIGN STATIC IP ADDRESSES

To change the PC/computer's IP address: (in Windows 7/8).

- 1) Type "network and sharing" into the Search box in the Start Menu and select Network and Sharing Center when displayed.
- 2) Then when the Network and Sharing Center opens, click on Change adapter settings.

3) Right-click on your local adapter and select Properties.

4) In the Local Area Connection Properties window highlight Internet Protocol Version 4 (TCP/IPv4), then click the Properties button.

5) Select the radio button and enter the correct IP address. (Ex. 192.168.1.100, and Subnet mask 255.255.0.0. The PC static IP address should be in the same IP address range as the SEM3™ controller.)

6) Click OK to close out of the Local Area Connections Properties window.

To confirm, open the command prompt and do an "ipconfig" to see if the network adapter settings have been successfully changed.

How to "Ping" your SEM3 Controller: (Default IP address: 192.168.1.65)

Open a Command Prompt and in the prompt type "ping" followed by a space and the IP Address of the SEM3™ and press **Enter**. (Do NOT type the quotation marks.)

The following should appear in the prompt window:

```
Pinging 192.168.1.65 with 32 bytes of data:
Reply from 192.168.1.65: bytes=32 time=56ms TTL=250
Reply from 192.168.1.65: bytes=32 time=60ms TTL=250
Reply from 192.168.1.65: bytes=32 time=69ms TTL=250
Reply from 192.168.1.65: bytes=32 time=78ms TTL=250
Ping statistics for 192.168.1.65:
    Packets: Sent = 4, Received = 4, Lost = 0 (0% loss),
    Approximate round trip times in milli-seconds:
        Minimum = 56ms, Maximum = 78ms, Average = 65ms
```

If not, then check your connection between the PC's Ethernet port and the Controller MODBUS TCP/IP port.

Open a browser (such as Explorer, Chrome, etc.) and type the IP address **192.168.1.65** in the top window. Default user name is **admin**. Default password is **SEM3**. User name and password can be set to user preference and ARE case-sensitive. Default login brings user in at Supervisor level so that all screens can be seen and modified. It is recommended that user account(s) and password(s) be set as soon as possible.

To reset user name and password navigate to the **User Profile** page.

7.2 Web User Interface

For a detailed description on using the web user interface of the SEM3™ product please refer to the **SEM3™ User Manual** or **Quick Reference Guide** found at www.usa.siemens.com/SEM3.

7.3 Addressing the Meter Racks

SEM3™ meter racks are hard-coded with discrete addresses that allow simultaneous module-to-controller communications. Three and six meter racks have a rotary dial for adjusting the racks address range. All meter racks are shipped from the factory with the rotary switch set to 0. Upon installation and set-up the installer must adjust the rotary switch to uniquely address each rack networked with a common controller. See Table 1. The rotary switch is shown in Figure 10.

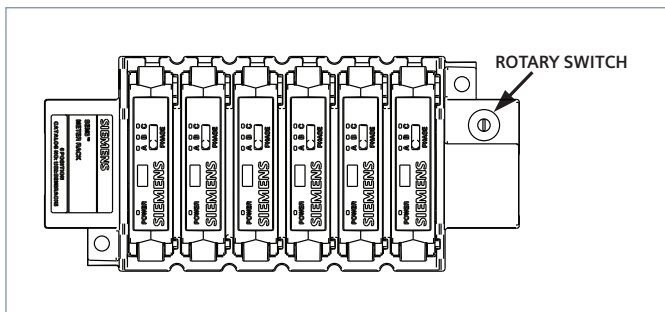

Figure 10: Six Pole Meter Module Rack with 10 Position Rotary Switch

Note: Meter racks are internal to the bus plug. However, a view port with rotary switch access hole allows the user to ensure proper phasing of the meter modules and verify that they are receiving power. The small hole over the rotary switch allows for the rack to be addressed without opening the bus plug cover. The location of the six meter rack is shown in Figure 11. It may be necessary to remove the front cover of the plug to access and adjust the rotary switch. Loosen the two thumb screws on the bus plug cover to access the rack.

DANGER: Ensure that breakers are in the OFF position before removing the bus plug cover. Contact with live conductors will result in serious injury or death.

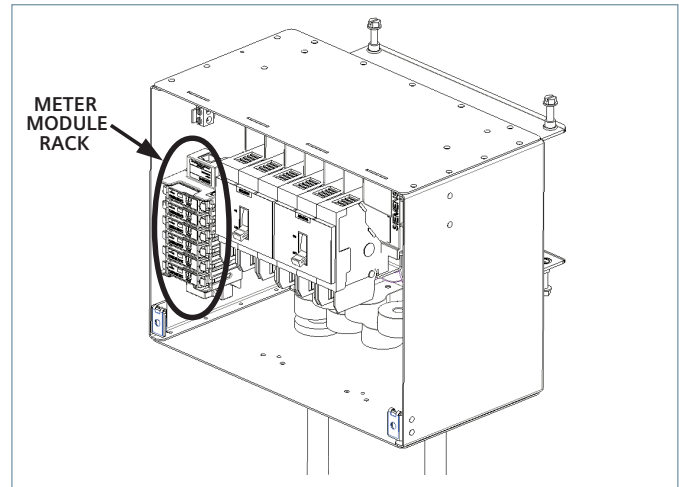

Figure 11: Internal Location of Meter Module Rack In Metered Bus Plug

Note that the internal layout of the bus plug is common for metered and controller bus plugs. In either case, the rotary switch must be adjusted to suit the network configuration. See Table 1.

Depending on the number of "daisy chained" bus plugs, three meter module rack rotary switches are set to one of the following: 0, 1, 2, 3, 4, 5, 6, 7, 8, 9, A, B, C, D, E or F. Each "daisy chained" meter module rack communicating with the same controller must be assigned a unique switch setting. Similarly, six position racks are set to one of the following: 0, 1, 2, 3, 4, 5, 6, 7, 8 or 9. This is illustrated in Table 1.

It is critical to note that there is an exclusivity condition for the six meter module racks. **0** and **8** cannot both be chosen as rotary switch settings for six position racks communicating with the same controller. This is also the case for six position rack designations **1** and **9**. This is because Modbus addresses cannot be repeated when communicating with the same controller. See Table 1.

If a combination of three and six meter plugs is required then the user must ensure that the corresponding Modbus addresses are not repeated between the three and six meter racks. Also remember that the maximum number of poles that the controller can monitor is 45 (given cable length restrictions in section 6.3).

Table 1 illustrates the Modbus Addressing Schemes as a function of rotary switch settings for both the three and six meter module rack bus plugs.

Once the rotary switch has been set, replace the bus plug covers and properly label the plug's rack setting and controller on the cover label. It is now safe to turn the breakers to the **ON** position.

Table 1: Modbus Addressing for Meter Modules

Single Phase Monitor Modbus Addresses	3 Position Rack Rotary Switch Setting	3 Position Rack Modbus Addresses	6 Position Rack Rotary Switch Setting	6 Position Rack Modbus Addresses	Single Phase Monitor Modbus Addresses	3 Position Rack Rotary Switch Setting	3 Position Rack Modbus Addresses	6 Position Rack Rotary Switch Setting	6 Position Rack Modbus Addresses
1	0	1	0*	1	33	8	33	4	33
2		2		2	34		34		
3		3		3	35		35		
4				4	36		36		
5	1	5		5	37	9	37		37
6		6	6	38	38				
7		7		39	39				
8					40				
9	2	9	1*	9	41	A	41	5	41
10		10		10	42		42		
11		11		11	43		43		
12				12	44				44
13	3	13		13	45	B	45		45
14		14	14	46	46				
15		15		47	47				
16					48				
17	4	17	2	17	49	C	49	6	49
18		18		18	50		50		
19		19		19	51		51		
20				20	52				52
21	5	21		21	53	D	53		53
22		22	22	54	54				
23		23		55	55				
24					56				
25	6	25	3	25	57	E	57	7	57
26		26		26	58		58		
27		27		27	59		59		
28				28	60				60
29	7	29		29	61	F	61		61
30		30	30	62	62				
31		31		63	63				
32					63				

*Rotary switch addressing setting of **0** is identical to that of **8**, similarly **1** is identical to **9**. This means racks with switch settings of **0** and **8** or **1** and **9** cannot be connected to the same controller for the six meter module racks.

8.0 Sample Network Topology

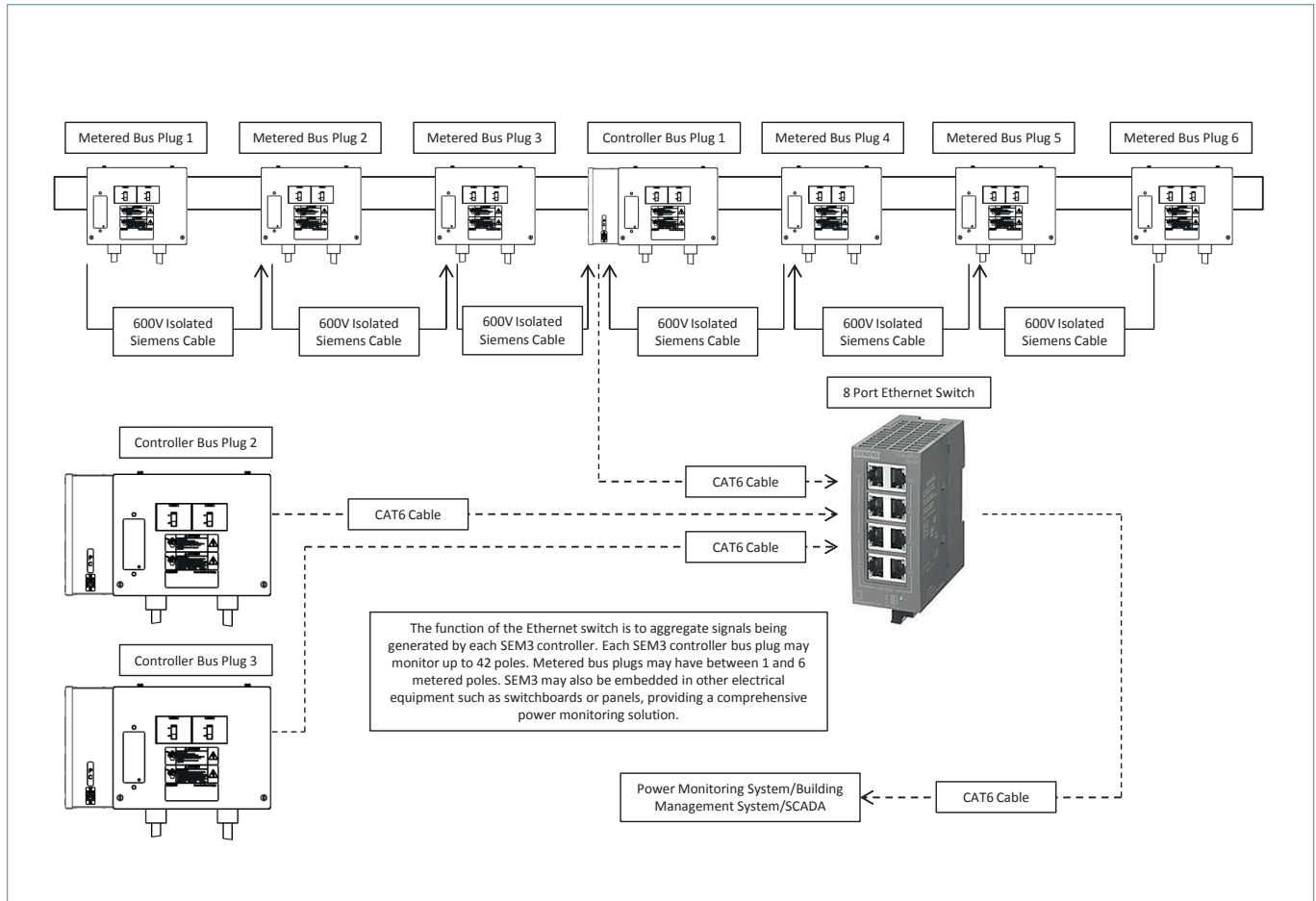

Many applications consist of long straight runs of busway with regularly spaced bus plugs. In the above diagram, a segment of a typical typical busway application is shown. In this case the end user has requested six pole metering in each bus plug. The run above consists of 7 six pole plugs, meaning 42 poles are monitored by the one controller bus plug located in the middle of the run.

Note that this configuration is within the 45 meter limitation for the maximum number of poles monitored by one SEM3™ controller. Additionally the maximum length of 600V isolated communication cable for 24 meters or more is 60 feet. Five plugs fit on every 10 foot section of bus, meaning the configuration is well within the 60 foot limit.

The rotary switches on the racks are set to unique identifiers for each rack, ranging from 0 in the left-most plug to 7 in the right. The isolated communication cable is "daisy chained"

from plug to plug on the rear surface. Isolated communications cable enters the control module through the ports labeled R1 and R2. This input completes the first level of data aggregation at the controller level.

A CAT6 Ethernet cable, with maximum suggested length of 200 feet, exits the PC port of the controller plug. An Ethernet switch is used to aggregate data from multiple controllers located throughout the facility. These controllers are located to monitor existing power cable runs. The Ethernet switch acts to consolidate the data, and routes it via CAT6 to a master building management system.

9.0 Additions to the Network

If additional plugs are required after an initial installation, one of two procedures should be followed.

If there is inadequate controller metering capacity, such that the new meters cannot be connected to an existing installed controller bus plug, a new controller bus plug must be installed. This plug will NOT be "daisy chained" to any neighbors, and addressing the rack is not required (default setting 0). CAT6 cable must be run from the PC port to the selected data aggregator. See Section 6.3 for CAT6 wiring instructions. Refer to Section 7.0 for commissioning an additional controller.

If the existing installation allows for any meters in an additional plug to be uniquely addressed, then a controller plug is not required. Simply install the additional plug per Section 6.0. The rotary switch must be set so as to uniquely address the meters in the new bus plug, see Section 7.3 to address the meter rack appropriately. "Daisy chain" the isolated communication cable to the neighboring plug per Section 6.3. The meters will be visible via the controller they are connected to.

If a SCADA system is integrated with the SEM3™ network, additional steps may be required to integrate any system modifications or new metering points. See Section 10.0.

10.0 Contact Information and Support

For PRE-sales support questions, contact Siemens Customer Support at **1-866-663-7324**.

For POST-sales support questions, contact Siemens Technical Support at **1-800-333-7421**.

NOTE: THESE PROCEDURES DO NOT REPRESENT AN EXHAUSTIVE SURVEY OF MAINTENANCE STEPS NECESSARY TO ENSURE SAFE OPERATION OF THE EQUIPMENT. PARTICULAR APPLICATIONS MAY REQUIRE ADDITIONAL PROCEDURES. SHOULD ADDITIONAL INFORMATION BE DESIRED OR SHOULD PARTICULAR PROBLEMS ARISE WHICH ARE NOT COVERED SUFFICIENTLY FOR THE PURCHASER'S PURPOSES, THE MATTER SHOULD BE REFERRED TO THE LOCAL SIEMENS SALES OFFICE OR CALL 1-800-241-4453 FOR EMERGENCY CUSTOMER SERVICE.

Notes:

Notes:

Notes:

Notes:

Subject to changes and errors. The information given in this document only contains general descriptions and/or performance features which may not always specifically reflect those described, or which may undergo modification in the course of further development of the products. The requested performance features are binding only when they are expressly agreed upon in the concluded contract.

Siemens Industry, Inc.
5400 Triangle Parkway
Norcross, GA 30092

1-800-241-4453
info.us@siemens.com

Subject to change without prior notice
Order No. BUIM-SEN36-0516
Printed in USA
All rights reserved
© 2016 Siemens Industry, Inc.