

Rosemount™ 5900S

Radar Level Gauge



NOTICE

Read this manual before working with the product. For personal and system safety, and for optimum product performance, make sure you thoroughly understand the contents before installing, using, or maintaining this product.

For equipment service or support needs, contact your local Emerson Automation Solutions/Rosemount Tank Gauging representative.

Spare Parts

Any substitution of non-recognized spare parts may jeopardize safety. Repair, e.g. substitution of components etc, may also jeopardize safety and is under no circumstances allowed.

Rosemount Tank Radar AB will not take any responsibility for faults, accidents, etc caused by non-recognized spare parts or any repair which is not made by Rosemount Tank Radar AB.

Specific ETSI Requirements (Europe)

The Rosemount 5900S is required to be installed at a permanent fixed position at a closed (not open) metallic tank or reinforced concrete tank, or similar enclosure structure made of comparable attenuating material. Flanges and attachments of the Rosemount 5900S equipment shall provide the necessary microwave sealing by design.

Manholes or connection flanges at the tank shall be closed to ensure a low-level leakage of the signal into the air outside the tank.

Installation and maintenance of the Rosemount 5900S equipment shall be performed by professionally trained individuals only.

Specific FCC Requirements (USA)

Rosemount 5900S generates and uses radio frequency energy. If it is not installed and used properly, that is, in strict accordance with the manufacturer's instructions, it may violate FCC regulations on radio frequency emission.

Rosemount TankRadar 5900S has been FCC certified under test conditions which assume a metallic tank.

Specific IC Requirements (Canada)

Radio approvals for this device apply for installation in complete enclosed container to prevent unwanted RF emission. In open air application site license is required. Installation shall be done by trained installers, in compliance with the manufacturer's instructions.

The use of this device is on a "no-interference, no-protection" basis. That is, the user shall accept operations of high-powered radar in the same frequency band which may interfere with or damage this device. Devices found to interfere with primary licensing operations will be required to be removed at the user's expense.

Low Emission of Microwave Radiation

The microwave radiation emitted by a Rosemount 5900S radar level gauge is very low compared to limits given by the Rec. 1999/519/EC (much less than 0.1 mW). No additional safety measures are needed.

⚠ CAUTION

The products described in this document are NOT designed for nuclear-qualified applications. Using non-nuclear qualified products in applications that require nuclear-qualified hardware or products may cause inaccurate readings. For information on Rosemount nuclear-qualified products, contact your local Emerson Sales Representative.

⚠ WARNING

WARNING - Substitution of components may impair Intrinsic Safety.

AVERTISSEMENT - La substitution de composants peut compromettre la sécurité intrinsèque.

WARNING - To prevent ignition of flammable or combustible atmospheres, disconnect power before servicing.

AVERTISSEMENT - Ne pas ouvrir en cas de présence d'atmosphère explosive.

Contents

Chapter 1	Introduction.....	7
	1.1 Safety messages.....	7
	1.2 Symbols.....	8
	1.3 Manual overview.....	9
	1.4 Technical documentation.....	10
	1.5 Service support.....	11
	1.6 Product recycling/disposal.....	11
	1.7 Packing material.....	11
Chapter 2	Overview.....	13
	2.1 Introduction.....	13
	2.2 Main label.....	15
	2.3 Components.....	16
	2.4 System overview.....	17
	2.5 Antennas.....	24
	2.6 Installation procedure.....	26
Chapter 3	Installation.....	27
	3.1 Safety messages.....	27
	3.2 Installation considerations.....	29
	3.3 Mechanical installation.....	47
	3.4 Electrical installation.....	77
Chapter 4	Configuration.....	95
	4.1 Safety messages.....	95
	4.2 Overview.....	96
	4.3 Configuration using Rosemount TankMaster.....	99
	4.4 Basic configuration.....	100
	4.5 Advanced configuration.....	111
	4.6 LPG configuration.....	116
	4.7 Calibration using WinSetup.....	129
	4.8 FOUNDATION™ Fieldbus overview.....	133
	4.9 Device capabilities.....	137
	4.10 General block information.....	138
	4.11 Analog Input block.....	140
	4.12 Analog Output block.....	147
	4.13 Resource block.....	149
	4.14 475 Field Communicator Menu Tree.....	154
	4.15 Configuration using AMS Device Manager.....	155

	4.16 Alert setup.....	171
	4.17 LPG Setup using DeltaV / AMS Device Manager.....	175
Chapter 5	Operation.....	183
	5.1 Safety messages.....	183
	5.2 Viewing measurement data in Rosemount TankMaster.....	184
	5.3 Alarm handling.....	184
	5.4 Viewing measurement data in AMS Device Manager.....	185
Chapter 6	Service and troubleshooting.....	187
	6.1 Safety messages.....	187
	6.2 Service.....	188
	6.3 Troubleshooting.....	203
	6.4 Resource block.....	214
	6.5 Transducer block.....	214
	6.6 Analog Input (AI) function block.....	215
	6.7 Alerts.....	216
	6.8 Viewing device status in AMS Device Manager.....	220
Appendix A	Specifications and reference data.....	223
	A.1 General.....	223
	A.2 Communication / Display / Configuration.....	224
	A.3 FOUNDATION™ Fieldbus characteristics.....	224
	A.4 Electric.....	226
	A.5 Mechanical.....	226
	A.6 Environment.....	228
	A.7 Rosemount 5900S SIL 2 version (SIS option code S).....	229
	A.8 Rosemount 5900S SIL 3 version (SIS option code 3).....	229
	A.9 Rosemount 5900S with parabolic antenna.....	230
	A.10 Rosemount 5900S with horn antenna.....	231
	A.11 Rosemount 5900S with still-pipe array antenna.....	231
	A.12 Rosemount 5900S with LPG/LNG antenna.....	232
	A.13 Dimensional drawings.....	234
	A.14 Ordering information.....	238
Appendix B	Product Certifications.....	253
	B.1 European directive information.....	253
	B.2 Ordinary Location Certification.....	253
	B.3 Telecommunication compliance.....	253
	B.4 CE-mark.....	253
	B.5 Installing Equipment in North America.....	254
	B.6 North America.....	254
	B.7 Europe.....	256
	B.8 International.....	257

B.9 Brazil.....	258
B.10 China.....	259
B.11 Technical Regulations Customs Union (EAC).....	259
B.12 Japan.....	259
B.13 Republic of Korea.....	260
B.14 Additional Certifications.....	260
B.15 Custody Transfer Certifications.....	261
B.16 Product Certifications Rosemount 2051	263
B.17 Approval Drawings.....	265
Appendix C FOUNDATION™ Fieldbus Block Information.....	267
C.1 Resource block.....	267
C.2 Analog Input block.....	273
C.3 Analog Output block.....	277
C.4 Measurement Transducer block.....	279
C.5 Volume Transducer block.....	286
C.6 Register Transducer block.....	287
C.7 Advanced Configuration Transducer block.....	289
C.8 LPG Transducer block	293
C.9 Supported units.....	296

1 Introduction

1.1 Safety messages

Instructions and procedures in this section may require special precautions to ensure the safety of the personnel performing the operations. Information that potentially raises safety issues is indicated by a warning symbol () . Refer to the following safety messages before performing an operation preceded by this symbol.

WARNING

Failure to follow these installation guidelines could result in death or serious injury.

- Ensure only qualified personnel perform the installation.
- Use the equipment only as specified in this manual. Failure to do so may impair the protection provided by the equipment.

Explosions could result in death or serious injury.

- Verify that the operating atmosphere of the transmitter is consistent with the appropriate hazardous locations certifications.
- Before connecting a handheld communicator in an explosive atmosphere, ensure that the instruments in the loop are installed in accordance with intrinsically safe or non-incendive field wiring practices.
- Do not remove the gauge cover in explosive atmospheres when the circuit is alive.

Electrical shock could cause death or serious injury.

- Use extreme caution when making contact with the leads and terminals.

WARNING

Any substitution of non-recognized parts may jeopardize safety. Repair, e.g. substitution of components, etc. may also jeopardize safety and is under no circumstances allowed.

WARNING





Physical access

Unauthorized personnel may potentially cause significant damage to and/or misconfiguration of end users' equipment. This could be intentional or unintentional and needs to be protected against.

Physical security is an important part of any security program and fundamental to protecting your system. Restrict physical access by unauthorized personnel to protect end users' assets. This is true for all systems used within the facility.

1.2 Symbols

Table 1-1: Symbols

	The CE marking symbolizes the conformity of the product with the applicable European Community Directives.
	The EU-Type Examination Certificate is a statement of a Notified Certification Body declaring that this product meets the Essential Health and Safety Requirements of the ATEX directive
	The FM APPROVED Mark indicates that the equipment is approved by FM Approvals according to applicable Approval Standards and is applicable for installation in hazardous locations
	Protective Earth
	Ground
81 C	External cabling must be approved for use in min. 81°C

1.3 Manual overview

This manual provides installation, configuration, and maintenance information for the Rosemount 5900S Series Radar Level Gauge. The manual is based on a typical Rosemount Tank Gauging system with a Rosemount 2410 Tank Hub connected to supported devices such as the Rosemount 5900S. It also includes a brief overview of FOUNDATION™ Fieldbus, and provides device specific information to allow installation of a Rosemount 5900S in Foundation fieldbus networks.

Chapter [Overview](#) provides a brief description of the various components in a Rosemount Tank Gauging system and recommended installation procedure.

Chapter [Installation](#) covers installation considerations as well as mechanical and electrical installation.

Chapter [Configuration](#) describes how to configure the Rosemount 5900S by using tools such as Rosemount TankMaster, Rosemount 475 Field Communicator, or AMS Device Manager. This section also provides an overview of FOUNDATION™ Fieldbus operation with the Rosemount 5900S.

Chapter [Operation](#) describes how to view measurement data in TankMaster. It also provides a brief description of alarm handling.

Chapter [Service and troubleshooting](#) covers tools, troubleshooting, and various service instructions.

Appendix [Specifications and reference data](#) contains specifications, dimensional drawings, and ordering table.

Appendix [Product Certifications](#) contains information on approvals and certifications.

Appendix [FOUNDATION™ Fieldbus Block Information](#) describes the various function and transducer blocks which are used for the Rosemount 5900S.

1.4 Technical documentation

The Rosemount™ Tank Gauging System includes the following documentation:

Reference manuals

- Rosemount Tank Gauging System Configuration Manual (00809-0300-5100)
- Rosemount 2460 System Hub (00809-0100-2460)
- Rosemount 2410 Tank Hub (00809-0100-2410)
- Rosemount 5900S Radar Level Gauge (00809-0100-5900)
- Rosemount 5900 Proof Test with Reference Reflector (00809-0200-5900)
- Rosemount 5900C Radar Level Gauge (00809-0100-5901)
- Rosemount 2240S Multi-Input Temperature Transmitter (00809-0100-2240)
- Rosemount 2230 Graphical Field Display (00809-0100-2230)
- Rosemount 5300 Guided Wave Radar (00809-0100-4530)
- Rosemount 5400 Radar Level Transmitter (00809-0100-4026)
- Rosemount Tank Gauging Wireless System (00809-0100-5200)
- Rosemount TankMaster WinOpi (00809-0200-5110)

Product data sheets

- Rosemount Tank Gauging System Data Sheet (00813-0100-5100)
- Rosemount 2460 System Hub Product Data Sheet (00813-0100-2460)
- Rosemount 2410 Product Data Sheet (00813-0100-2410)
- Rosemount 5900S Product Data Sheet (00813-0100-5900)
- Rosemount 5900C Product Data Sheet (00813-0100-5901)
- Rosemount 2240S Product Data Sheet (00813-0100-2240)
- Rosemount 2230 Product Data Sheet (00813-0100-2230)
- Rosemount 5300 Product Data Sheet (00813-0100-4530)
- Rosemount 5400 Product Data Sheet (00813-0100-4026)

1.5 Service support

For service support contact the nearest Emerson Automation Solutions /Rosemount Tank Gauging representative. Contact information can be found on the web site www.Emerson.com.

1.6 Product recycling/disposal

Recycling of equipment and packaging should be taken into consideration and disposed of in accordance with local and national legislation/regulations.

1.7 Packing material

Rosemount Tank Radar AB is fully certified according to ISO 14001 environmental standards. By recycling the corrugated paperboard, or wooden boxes, used for shipping our products you can contribute to take care of the environment.

Reuse and recycling

Experience has shown that wooden boxes can be used several times for various purposes. After careful disassembly the wooden parts may be reused. Metal waste may be converted.

Energy recovery

Products which have served their time may be divided into wood and metal components and the wood can be used as fuel in sufficient ovens.

Due to its low moisture content (approximately 7%) this fuel has a higher calorific value than ordinary wood fuel (moisture content approximately 20%).

When burning interior plywood the nitrogen in the adhesives may increase emissions of nitrogen oxides to the air 3-4 times more than when burning bark and splinter.

Note

Landfill is not a recycling option and should be avoided.

2 Overview

2.1 Introduction

The Rosemount™ 5900S is a two-wire radar level gauge for high accuracy non-contact measurements. The level gauge continuously emits a radar signal with varying frequency towards the product surface. This allows very accurate level measurements by processing the difference between the frequencies of the emitted and received radar signals.

The Rosemount 5900S is an integral part of the flexible Rosemount Tank Gauging system. The advanced and robust design makes it suitable for a vast range of applications. It is designed for high accuracy level measurements as well as handling complex tank shapes and obstacles in the tank that may interfere with measurement signals.

Figure 2-1: System Integration

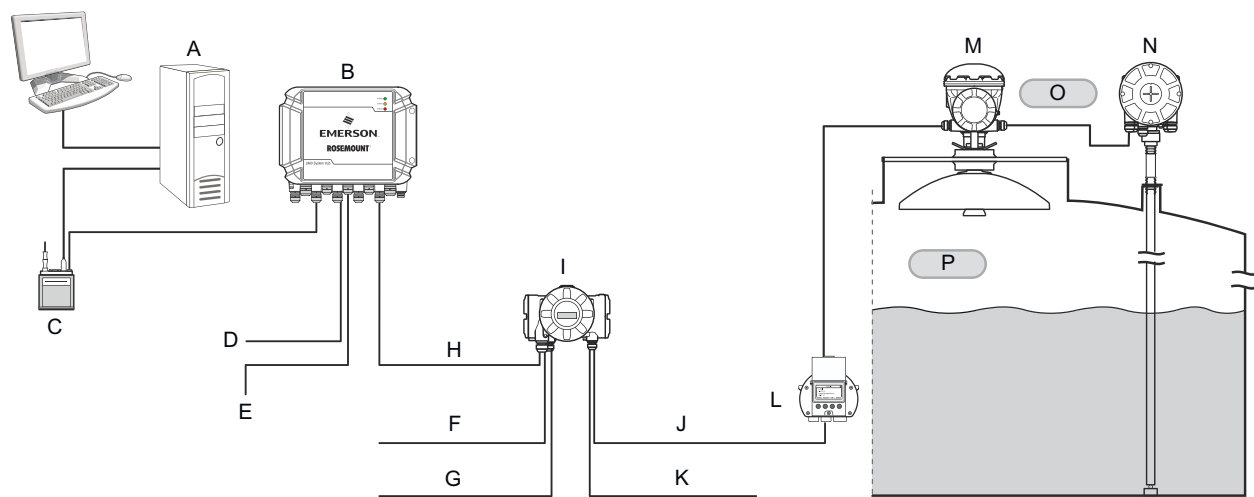

- | | |
|------------------------------|--|
| A. Rosemount TankMaster | I. Rosemount 2410 Tank Hub |
| B. Rosemount 2460 System Hub | J. Tankbus |
| C. Modem | K. Secondary bus (IS) |
| D. Host | L. Rosemount 2230 Field Display |
| E. Servo gauges | M. Rosemount 5900S Radar Level Gauge |
| F. Secondary Bus (Non-IS) | N. Rosemount 2240S Temperature Transmitter |
| G. Relay Outputs | O. Zone 1 |
| H. Primary Bus | P. Zone 0 |

The Rosemount 5900S delivers measurement data and status information to a Rosemount 2410 Tank Hub via the intrinsically safe Tankbus⁽¹⁾. Data from a group of tanks is buffered

⁽¹⁾ The intrinsically safe Tankbus complies with the FISCO FOUNDATION™ Fieldbus standard.

by a Rosemount 2460 System Hub, and is distributed to a Rosemount TankMaster PC, or another host system, whenever the system hub receives a request for data.

2.2 Main label

Figure 2-2: Rosemount 5900S Main Label

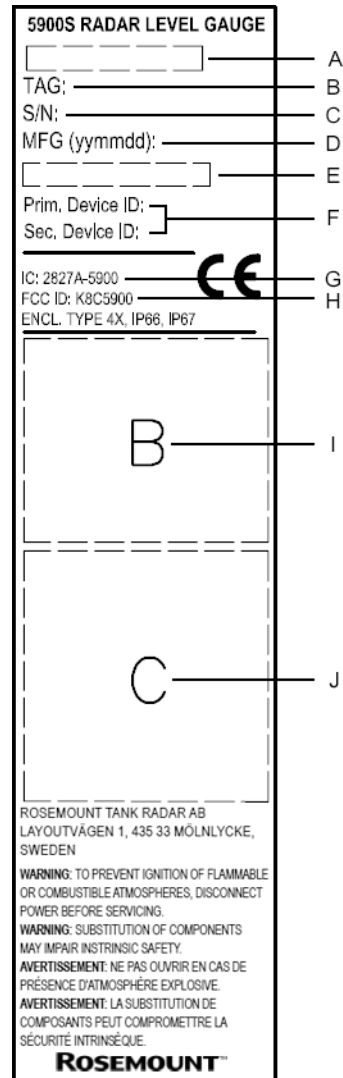

- A. Model Code
- B. Tag number
- C. Serial number
- D. Manufacturing date
- E. SIL Baseline
- F. Device Id
- G. IC Id
- H. FCC Id
- I. Explosion protection
- J. Explosion protection

2.3 Components

Figure 2-3: Rosemount 5900S Components

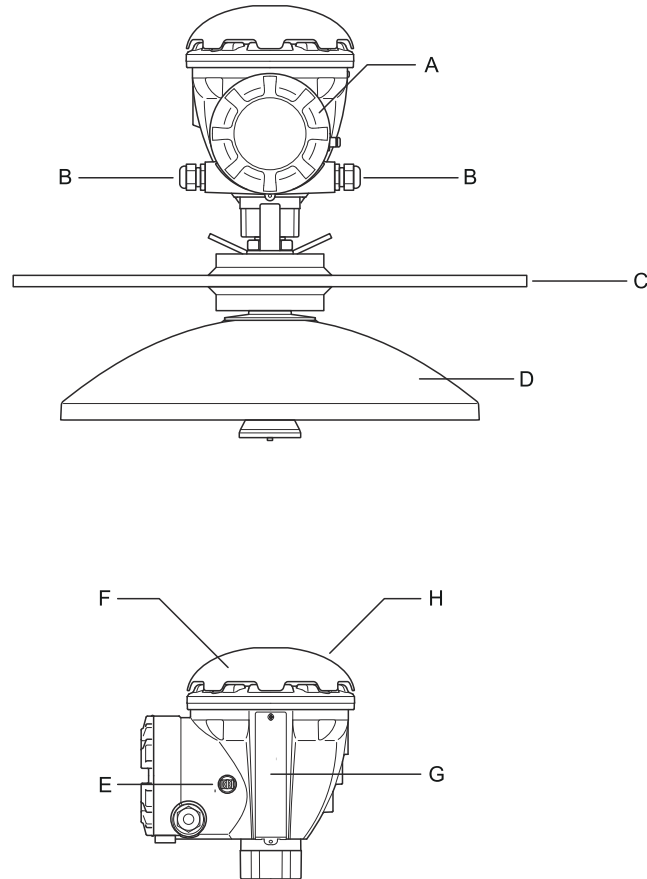

- A. *Terminal compartment*
- B. *Cable entries ($\frac{1}{2}$ - 14 NPT, M20 x 1.5 adapters)*
- C. *Flange*
- D. *Antenna*
- E. *Grounding terminal*
- F. *Weather protection hood*
- G. *Label*
- H. *Transmitter head with signal processing electronics*

2.4 System overview

The Rosemount Tank Gauging system is a state-of-the art inventory and custody transfer radar tank level gauging system. It is developed for a wide range of applications at refineries, tank farms and fuel depots, and fulfills the highest requirements on performance and safety.

The field devices on the tank communicate over the intrinsically safe Tankbus. The Tankbus is based on a standardized fieldbus, the FISCO⁽²⁾ FOUNDATION™ Fieldbus, and allows integration of any device supporting that protocol. By utilizing a bus powered 2-wire intrinsically safe fieldbus the power consumption is minimized. The standardized fieldbus also enables integration of other vendors' equipment on the tank.

The Rosemount Tank Gauging product portfolio includes a wide range of components to build small or large customized tank gauging systems. The system includes various devices, such as radar level gauges, temperature transmitters, and pressure transmitters for complete inventory control. Such systems are easily expanded thanks to the modular design.

The Rosemount Tank Gauging system is a versatile system that is compatible with and can emulate all major tank gauging systems. Moreover, the well-proven emulation capability enables step-by-step modernization of a tank farm, from level gauges to control room solutions.

It is possible to replace old mechanical or servo gauges with modern Rosemount Tank Gauging devices, without replacing the control system or field cabling. It is further possible to replace old HMI/SCADA-systems and field communication devices without replacing the old gauges.

There is a distributed intelligence in the various system units which continuously collect and process measurement data and status information. When a request for information is received an immediate response is sent with updated information.

The flexible Rosemount Tank Gauging system supports several combinations to achieve redundancy, from control room to the different field devices. Redundant network configuration can be achieved at all levels by doubling each unit and using multiple control room work stations.

⁽²⁾ See documents IEC 61158-2

Figure 2-4: Rosemount Tank Gauging System Architecture

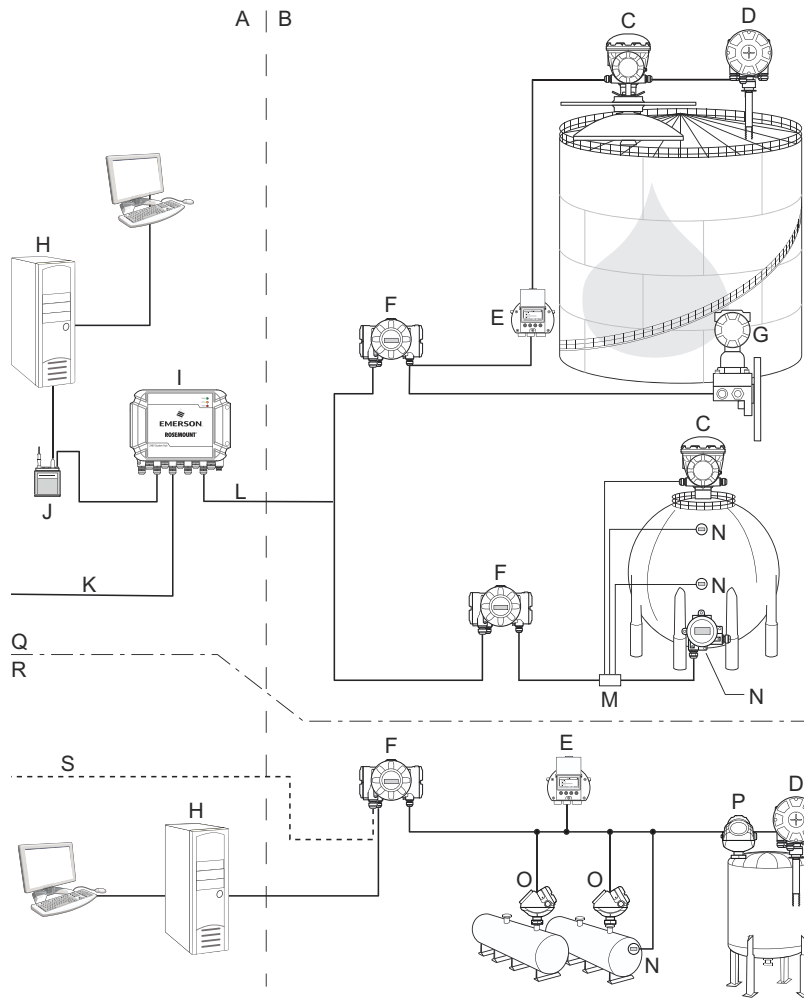

- | | |
|--|--|
| A. Non-hazardous area | K. Plant Host Computer |
| B. Hazardous area | L. TRL2 Modbus |
| C. Rosemount 5900S Radar Level Gauge | M. Segment coupler |
| D. Rosemount 2240S Temperature Transmitter | N. Rosemount 644 Temperature Transmitter |
| E. Rosemount 2230 Graphical Field Display | O. Rosemount 5300 Level Transmitter |
| F. Rosemount 2410 Tank Hub | P. Rosemount 5400 Level Transmitter |
| G. Rosemount 3051S Pressure Transmitter | Q. Custody transfer / Inventory tank gauging |
| H. Rosemount TankMaster PC | R. Operational control |
| I. Rosemount 2460 System Hub | S. Plant host computer |
| J. Rosemount 2180 Field Bus Modem | |

Figure 2-5: Rosemount Tank Gauging System Architecture for Wireless Systems

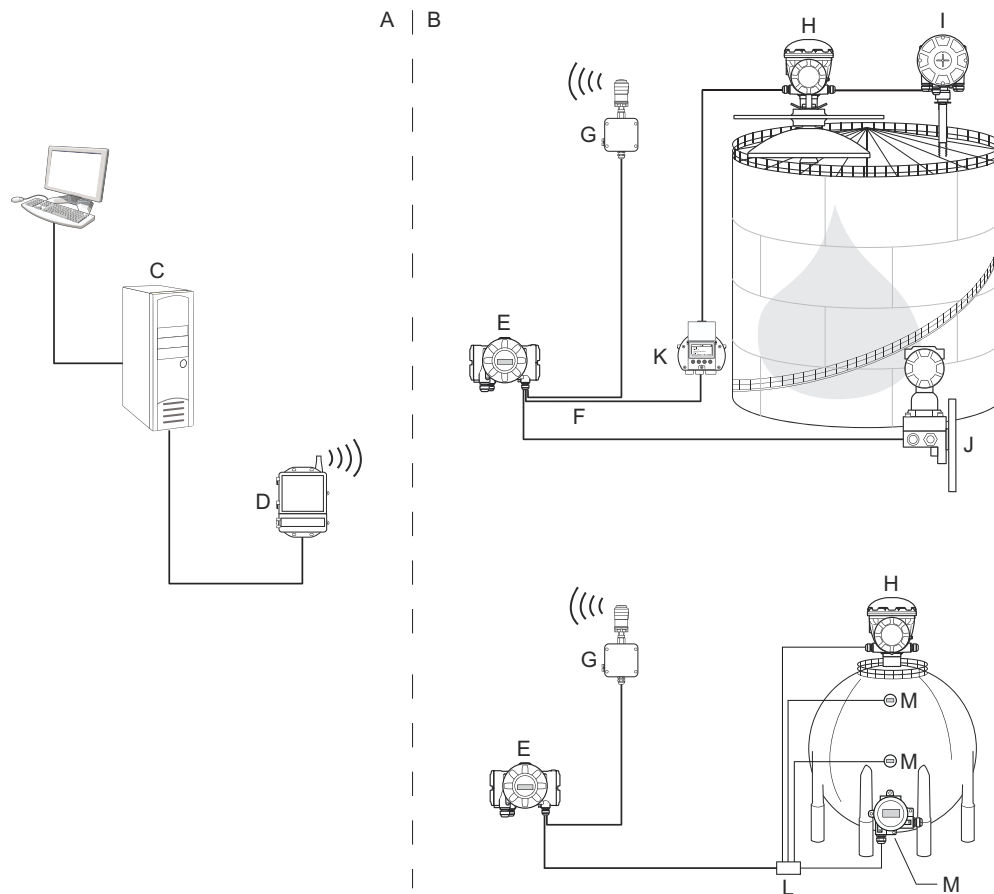

- A. Non-hazardous area
- B. Hazardous area
- C. Rosemount TankMaster PC
- D. Emerson Wireless 1420 Gateway
- E. Rosemount 2410 Tank Hub
- F. Tankbus
- G. Emerson Wireless 775 THUM Adapter
- H. Rosemount 5900S Radar Level Gauge
- I. Rosemount 2240S Temperature Transmitter
- J. Rosemount 3051S Pressure Transmitter
- K. Rosemount 2230 Graphical Field Display
- L. Segment coupler
- M. Rosemount 644 Temperature Transmitter

Figure 2-6: Rosemount Tank Gauging System Architecture in a FOUNDATION Fieldbus Network

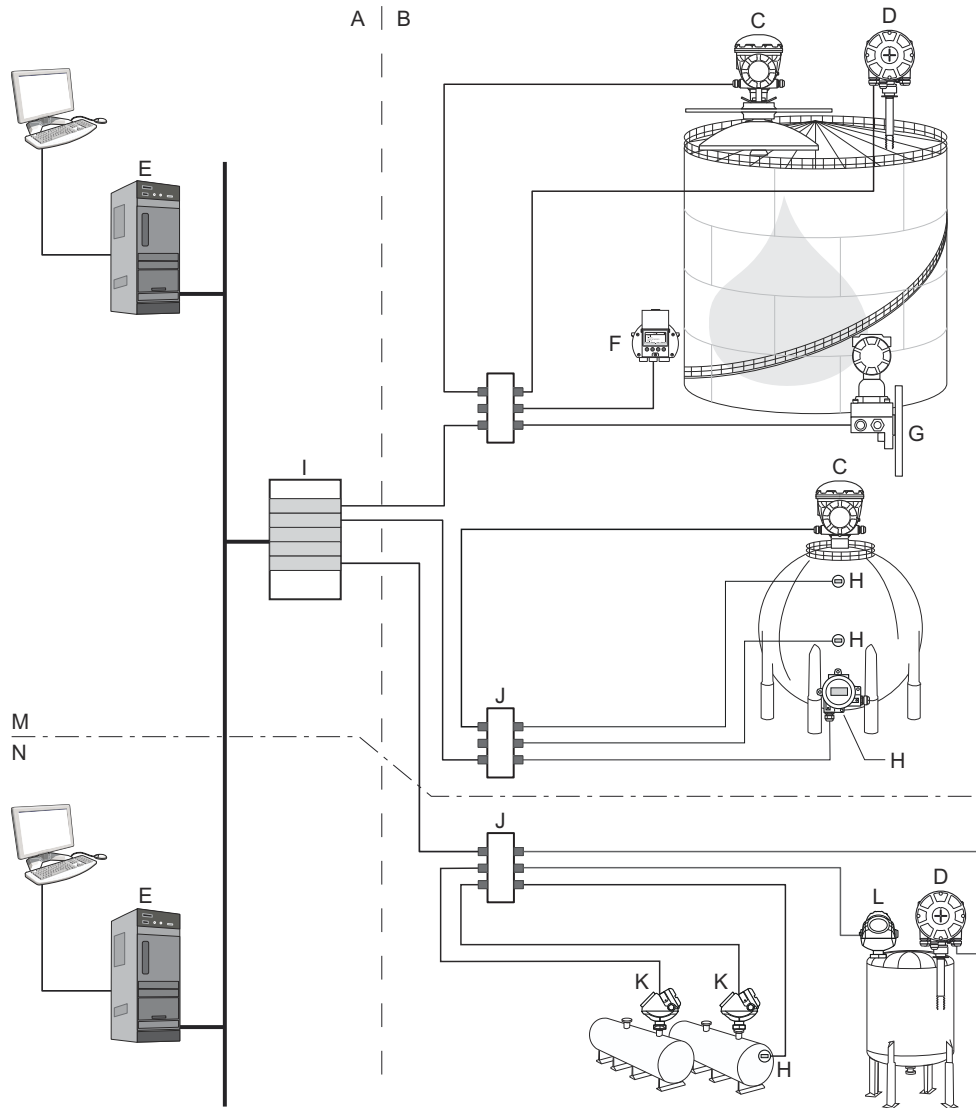

- | | | | |
|----|---|----|---|
| A. | Non-hazardous area | H. | Rosemount 644 Temperature Transmitter |
| B. | Hazardous area | I. | FOUNDATION Fieldbus Power Supply |
| C. | Rosemount 5900S Radar Level Gauge | J. | Segment coupler |
| D. | Rosemount 2240S Temperature Transmitter | K. | Rosemount 5300 Level Transmitter |
| E. | PC | L. | Rosemount 5400 Level Transmitter |
| F. | Rosemount 2230 Graphical Field Display | M. | Custody transfer / Inventory tank gauging |
| G. | Rosemount 3051S Pressure Transmitter | N. | Operational control |

2.4.1 TankMaster HMI software

Rosemount TankMaster is a powerful Windows-based Human Machine Interface (HMI) for complete tank inventory management. It provides configuration, service, set-up, inventory, and custody transfer functions for Rosemount Tank Gauging systems and other supported instruments.

Rosemount TankMaster is designed to be used in the Microsoft® Windows environment providing easy access to measurement data from your Local Area Network (LAN).

The Rosemount TankMaster WinOpi program lets the operator monitor measured tank data. It includes alarm handling, batch reports, automatic report handling, historical data sampling as well as inventory calculations such as Volume, Observed Density and other parameters. A plant host computer can be connected for further processing of data.

The Rosemount TankMaster WinSetup program is a graphical user interface for installation, configuration and service of devices in the Rosemount Tank Gauging system.

2.4.2 Rosemount 2460 System Hub

The Rosemount 2460 System Hub is a data concentrator that continuously polls and stores data from field devices such as radar level gauges and temperature transmitters in a buffer memory. Whenever a request for data is received, the system hub can immediately send data from the updated buffer memory for a group of tanks.

Measured and calculated data from one or more tanks is communicated via the Rosemount 2410 Tank Hub to the system hub buffer memory. Whenever a request is received, the system hub can immediately send data from a group of tanks to a TankMaster PC, or a host.

The Rosemount 2460 can be used to connect devices from other vendors as well, such as Honeywell® Enraf and Whessoe.

The Rosemount 2460 has eight slots for communication interface boards. These boards can be individually configured for communication with hosts or field devices. They can be ordered either for TRL2, RS485, Enraf BPM or Whessoe 0-20 mA/RS485 communication. Two slots can also be configured for RS232 communication.

One of the system hub's three Ethernet ports is used for Modbus TCP connection to host systems. By simply connecting the system hub to the existing LAN network, communication over Ethernet is established.

The system hub can provide redundancy for critical operations, by using two identical devices. The primary system hub is active and the other one is in passive mode. If the primary unit stops working properly, the secondary unit is activated and a failure message is sent to TankMaster (or a DCS system).

2.4.3 Rosemount 2410 Tank Hub

The Rosemount 2410 Tank Hub acts as a power supply to the connected field devices in the hazardous area using the intrinsically safe Tankbus.

The tank hub collects measurement data and status information from field devices on a tank. It has two external buses for communication with various host systems.

There are two versions of the Rosemount 2410 Tank Hub; one for single tank operation and one for multiple tanks operation. The multiple tanks version of the Rosemount 2410 supports up to 10 tanks and 16 devices. With the Rosemount 5300 and Rosemount 5400 level transmitters the Rosemount 2410 supports up to 5 tanks.

The Rosemount 2410 is equipped with two relays which support configuration of up to 10 “virtual” relay functions allowing you to specify several source signals for each relay.

The Rosemount 2410 supports Intrinsically Safe (IS) and Non-Intrinsically Safe (Non-IS) analog 4-20 mA inputs/outputs. By connecting an Emerson Wireless 775 THUM Adapter to the IS HART 4-20 mA output, the tank hub is capable of wireless communication with an Emerson Wireless Gateway in a *WirelessHART*® network.

2.4.4 Rosemount 5900S Radar Level Gauge

The Rosemount 5900S Radar Level Gauge is an intelligent instrument for measuring the product level inside a tank. Different antennas can be used in order to meet the requirements of different applications. The Rosemount 5900S can measure the level of almost any product, including bitumen, crude oil, refined products, aggressive chemicals, LPG and LNG.

The Rosemount 5900S sends microwaves towards the surface of the product in the tank. The level is calculated based on the echo from the surface. No part of the Rosemount 5900S is in actual contact with the product in the tank, and the antenna is the only part of the gauge that is exposed to the tank atmosphere.

The 2-in-1 version of the Rosemount 5900S Radar Level Gauge has two radar modules in the same transmitter housing allowing two independent level measurements using one antenna and one tank opening.

2.4.5 Rosemount 5300 Guided Wave Radar

The Rosemount 5300 is a premium 2-wire guided wave radar for level measurements on liquids, to be used in a wide range of medium accuracy applications under various tank conditions. Rosemount 5300 includes the Rosemount 5301 for liquid level measurements and the Rosemount 5302 for liquid level and interface measurements.

2.4.6 Rosemount 5400 Radar Level Transmitter

The Rosemount 5400 is a reliable 2-wire non-contact radar level transmitter for liquids, to be used in a wide range of medium accuracy applications under various tank conditions.

2.4.7 Rosemount 2240S Multi-Input Temperature Transmitter

The Rosemount 2240S Multi-input Temperature Transmitter can connect up to 16 temperature spot sensors and an integrated water level sensor.

2.4.8 Rosemount 2230 Graphical Field Display

The Rosemount 2230 Graphical Field Display presents inventory tank gauging data such as level, temperature, and pressure. The four softkeys allow you to navigate through the different menus to provide all tank data, directly in the field. The Rosemount 2230

supports up to 10 tanks. Up to three Rosemount 2230 displays can be used on a single tank.

2.4.9 Rosemount 644 Temperature Transmitter

The Rosemount 644 is used with single spot temperature sensors.

2.4.10 Rosemount 3051S Pressure Transmitter

The Rosemount 3051S series consists of transmitters and flanges suitable for all kinds of applications, including crude oil tanks, pressurized tanks and tanks with / without floating roofs.

By using a Rosemount 3051S Pressure Transmitter near the bottom of the tank as a complement to a Rosemount 5900S Radar Level Gauge, the density of the product can be calculated and presented. One or more pressure transmitters with different scalings can be used on the same tank to measure vapor and liquid pressure.

2.4.11 Rosemount 2180 Field Bus Modem

The Rosemount 2180 Field Bus Modem (FBM) is used for connecting a TankMaster PC to the TRL2 communication bus. The Rosemount 2180 is connected to the PC using either the USB or the RS232 interface.

2.4.12 Emerson Wireless Gateway and Emerson Wireless 775 THUM™ Adapter

An Emerson Wireless THUM Adapter allows wireless communication between a Rosemount 2410 Tank Hub and an Emerson Wireless Gateway. The gateway is the network manager that provides an interface between field devices and the Rosemount TankMaster inventory software or host / DCS systems.

See the Rosemount Tank Gauging [System Data Sheet](#) for more information on the various devices and options.

2.5 Antennas

2.5.1 Horn antenna

The Rosemount 5900S with Horn Antenna is designed for an 8 inch antenna to be used in small size openings on fixed roofs tanks.

The Rosemount 5900S is designed for measurements of a variety of oil products and chemicals. However, for bitumen/asphalt and similar products the Parabolic antenna is recommended.

Figure 2-7: Horn Antenna

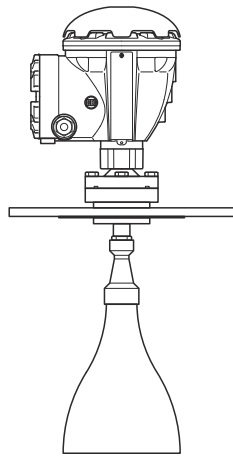

2.5.2 Parabolic antenna

The Rosemount 5900S with Parabolic Antenna measures level of all types of liquids, from light products to bitumen/asphalt. The gauge is designed for mounting on tanks with fixed roofs and has custody transfer accuracy.

The design of the parabolic antenna provides extreme tolerance against sticky and condensing products. The narrow beam of this antenna makes it very suitable in narrow tanks with internal structures.

Figure 2-8: Parabolic Antenna

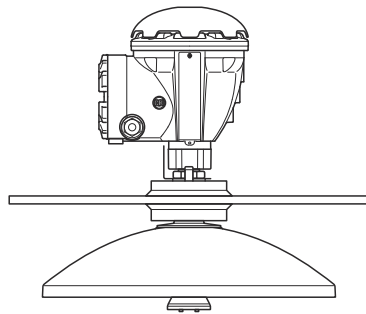

2.5.3 Array antenna

The Rosemount 5900S with Still-pipe Array Antenna is used on tanks with still pipes and with all products suited for still pipes, except Methanol, for which the other antennas are better suited.

The gauge uses a low-loss radar propagation mode which virtually eliminates the influence of the still pipe condition. Measurement is made with highest accuracy even when the pipe is old, rusty and covered with deposits.

The Still-pipe Array Antenna fits 5, 6, 8, 10, and 12 inch pipes. It can be mounted on an existing still pipe and there is no need to take the tank out of operation during installation.

There are two versions of the Rosemount 5900S with Still-pipe Array Antenna: fixed and hinged hatch. The hinged hatch enables full pipe size product sampling or verification hand-dips.

Figure 2-9: Array Antenna

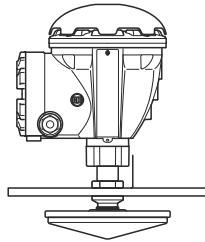

2.5.4 LPG/LNG Antenna

The Rosemount 5900S with LPG/LNG Antenna is designed for level measurements in LPG and LNG tanks. A 4 inch still-pipe is used as a wave guide for the measurement and prevents a turbulent surface from disturbing the measurement. Radar signals are transmitted inside the pipe towards the surface.

The pressure sealing is a PTFE window with drip-off design. It is approved for use in pressure vessels. As standard the gauge is equipped with a fire-proof block valve. An optional vapor space pressure sensor is also available.

The Rosemount 5900S with LPG/LNG Antenna is available in two versions for 150 PSI and 300 PSI.

The Verification Pin allows you to verify measurements without opening the tank by comparing the measured distance with the actual distance to the Verification Pin.

Figure 2-10: LPG/LNG Antenna

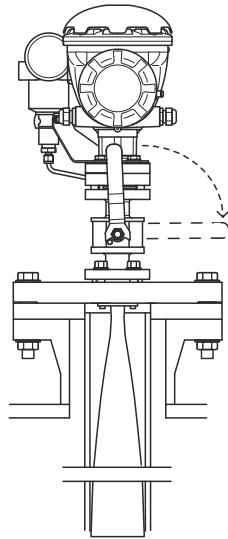

2.6 Installation procedure

Follow these steps for proper installation:

Procedure

1. Review installation considerations. See [Installation considerations](#).
2. Mount the gauge. See [Mechanical installation](#).
3. Wire the gauge. See [Electrical installation](#).
4. Make sure covers and cable/conduit connections are tight.
5. Power up the gauge.
6. Configure the gauge. See [Configuration](#).
7. Verify measurements.
8. (Optional) Enable the Write Protection switch.
9. (Optional) SIL configuration.

3 Installation

3.1 Safety messages

Instructions and procedures in this section may require special precautions to ensure the safety of the personnel performing the operations. Information that potentially raises safety issues is indicated by a warning symbol (⚠). Refer to the following safety messages before performing an operation preceded by this symbol.

⚠ WARNING

Failure to follow safe installation and servicing guidelines could result in death or serious injury.

- Ensure only qualified personnel perform the installation.
- Use the equipment only as specified in this manual. Failure to do so may impair the protection provided by the equipment.
- Do not perform any service other than those contained in this manual unless you are qualified.
- To prevent ignition of flammable or combustible atmospheres, disconnect power before servicing.
- Substitution of components may impair Intrinsic Safety.

Explosions could result in death or serious injury.

- Verify that the operating atmosphere of the transmitter is consistent with the appropriate hazardous locations certifications.
- Before connecting a handheld communicator in an explosive atmosphere, ensure that the instruments in the loop are installed in accordance with intrinsically safe or non-incendive field wiring practices.
- Do not remove the gauge cover in explosive atmospheres when the circuit is alive.

High voltage that may be present on leads could cause electrical shock.

- Avoid contact with the leads and terminals.
- Make sure the main power to the transmitter is off and the lines to any other external power source are disconnected or not powered while wiring the gauge.

NOTICE

The device is designed for installation in complete enclosed container to prevent unwanted RF emission. Installation must be in accordance with local regulations and may require local radio approvals.

Installation in open air applications may be subject for site license approval.

Installation shall be done by trained installers, in compliance with the manufacturer's instructions.

3.2 Installation considerations

When finding an appropriate location on the tank for a Rosemount 5900S Radar Level Gauge, the conditions of the tank must be carefully considered. The Rosemount 5900S should be installed so that the influence of disturbing objects is kept to a minimum, preferably outside the radar signal beam.

Ensure that environmental conditions are within specified limits as listed in [Specifications and reference data](#).

Ensure that the Rosemount 5900S Radar Level Gauge is installed such that it is not exposed to higher pressure and temperature than specified in [Specifications and reference data](#).

It is the responsibility of the user to ensure that the device meets the specific inside tank installation requirements such as:

- chemical compatibility of wetted materials
- design/operation pressure and temperature

For a complete specification of the Rosemount 5900S device, you can identify the model code on the attached antenna label and match with data in [Ordering information](#).

Do not install the Rosemount 5900S in non-intended applications, for example environments where it may be exposed to extremely intense magnetic fields or extreme weather conditions.

Antennas with plastic surfaces and painted surface, may under certain extreme conditions generate an ignition-capable level of electrostatic charge. When installing in hazardous areas ensure using tools, cleaning material etc. which can not generate electrostatic charge.

3.2.1 Horn antenna requirements

The Rosemount 5900S with Horn Antenna must be installed so that there are no pipes or other obstacles that could prevent the radar beam from reaching the tank bottom unobstructed. There are two flanges available; a horizontal flange for vertical installation, and an inclined flange for installation close to the tank wall.

Please refer to mechanical installation drawings for more information on the installation requirements of the Horn Antenna and service space requirements.

Nozzle requirements

Table 3-1: Minimum Nozzle Diameter for the Rosemount 5900S with Horn Antenna

Flange	Minimum nozzle diameter (mm/in.)	Maximum nozzle height (mm)
Horizontal flange	180/7.1	330
4° inclined flange	185/7.3	330

Figure 3-1: Nozzle Requirements for the Horn Antenna Gauge

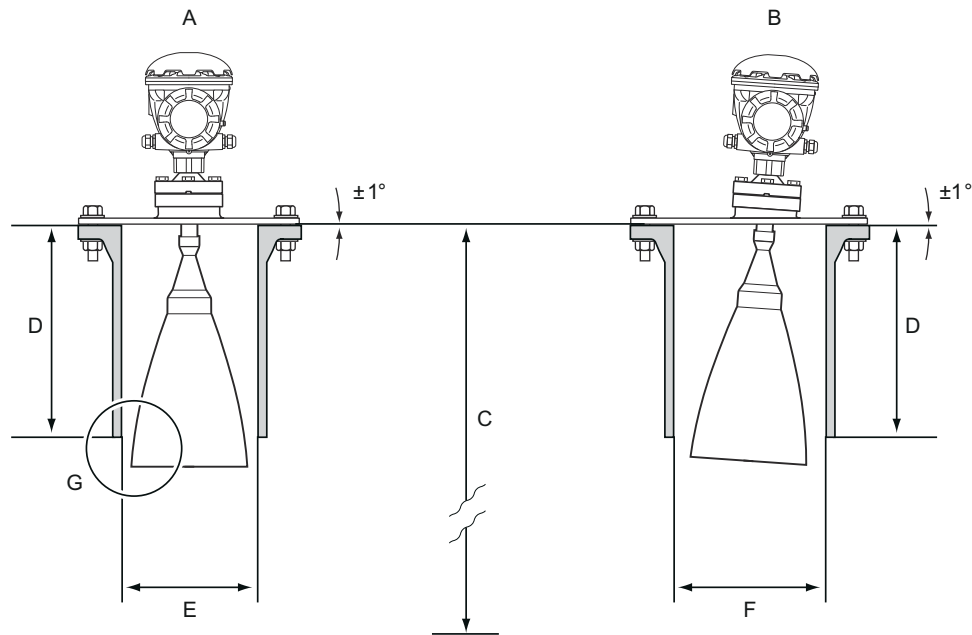

- A. Horizontal flange
- B. 4° inclined flange
- C. Minimum 800 mm (31.5 in.) for highest accuracy. Minimum 500 mm (19.7 in.) with reduced accuracy.
- D. Maximum height: 330 mm (13 in.)
- E. Minimum nozzle diameter 180 mm (7.1 in.)
- F. Minimum nozzle diameter 185 mm (7.3 in.)
- G. Note! For best performance the antenna should extend below the nozzle.

Free space requirements

There are two flanges available for the Horn Antenna gauge. One flange has a 4° inclination and the other is horizontal. See installation drawing for flange dimensions.

The horizontal flange can be used if the wall does not intrude into the 30° wide radar beam from the Horn Antenna.

In case a vertical antenna axis installation is not possible without the tank wall penetrating the radar beam, the Rosemount 5900S has to be directed away from the wall by using the 4° flange. The inclination is necessary to ensure maximum accuracy.

Consider minimum free space distance L according to [Table 3-2](#) and [Figure 3-2](#).

Table 3-2: Minimum Distance L to Tank Wall for the Rosemount 5900S with Horn Antenna

Flange	Minimum distance L to tank wall (m)
Horizontal flange	$R \times 0.2$ (R=tank reference height)
4° flange	0.6 ⁽¹⁾

(1) In exceptional cases the Rosemount 5900S with Horn Antenna can be installed closer to the tank wall if required. Please contact Emerson Automation Solutions/Rosemount Tank Gauging for advice.

In certain cases, when maximum accuracy is not required, the horizontal flange can be used even if the wall intrudes into the radar beam. In doubtful cases, please contact Emerson Automation Solutions / Rosemount Tank Gauging or one of its representatives for advice.

Figure 3-2: Two Different Flange Options are Available

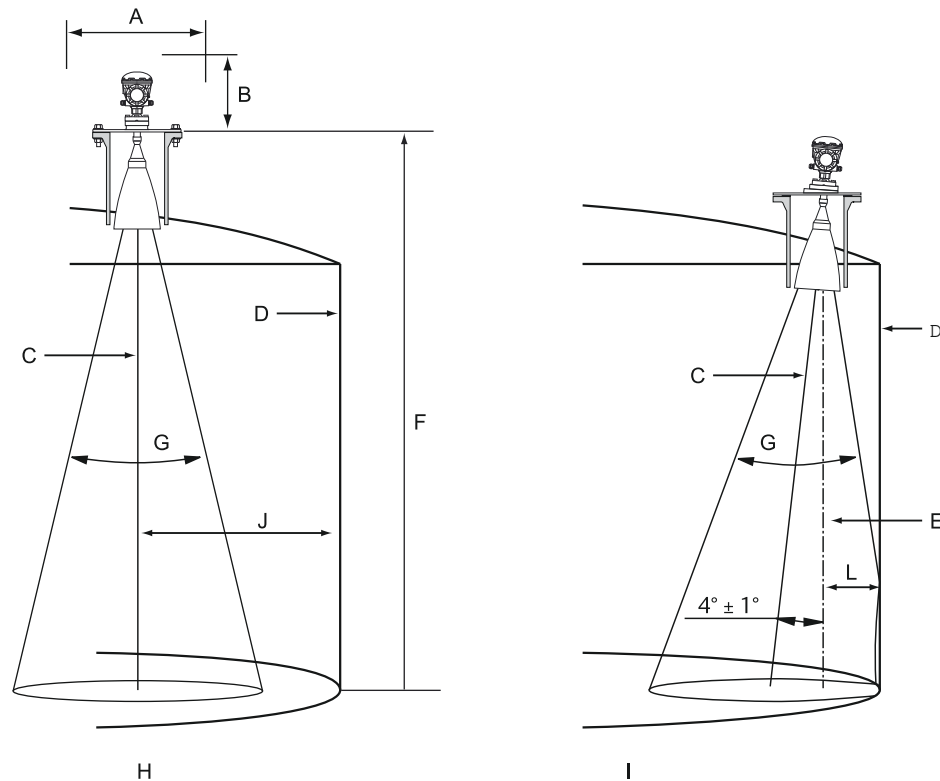

- A. Service space 550 mm (21.7 in.)
- B. Service space 500 mm (19.7 in.)
- C. Antenna axis
- D. Tank wall
- E. Vertical plumb line
- F. Tank reference height (R)
- G. 30° radar beam
- H. Horizontal flange
- I. Inclined flange
- J. Minimum distance (L) to tank wall

3.2.2 Parabolic antenna requirements

Inclination

The inclination of the Rosemount 5900S with Parabolic Antenna should not exceed 1.5° towards the center of the tank. For products with high condensation such as bitumen/ asphalt applications, the radar beam should be directed vertically without any inclination.

Figure 3-3: Maximum Inclination with Parabolic Antenna

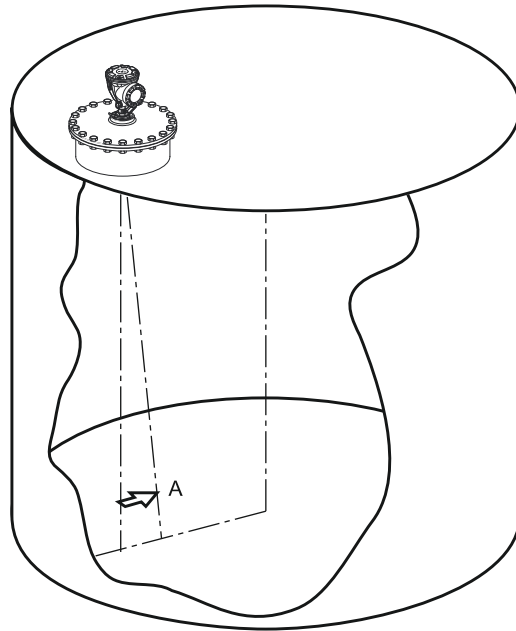

A. Maximum inclination 1.5°

Flange requirements

The Rosemount 5900S with Parabolic Antenna is mounted on the tank nozzle by using the Flange Ball. It is designed for easy adjustment of gauge inclination within the specified limits.

There are two versions of the Flange Ball. One that is clamped to the flange by using a nut, and another one which is welded to the flange.

The Flange Ball has to be mounted on the flange prior to mounting the gauge on the tank nozzle.

The flange needs to fulfill certain requirements in order to ensure that the radar beam is not disturbed by the tank wall. This allows the radar signal to be reflected on the product surface and transmitted back to the level gauge at a maximum signal strength.

The tank flange has to meet the following inclination requirements (see [Figure 3-4](#)) in order to allow proper adjustment of the antenna:

- maximum 4.5° away from the tank wall
- maximum of 2° towards the tank wall

Figure 3-4: Maximum Inclination of Tank Flange

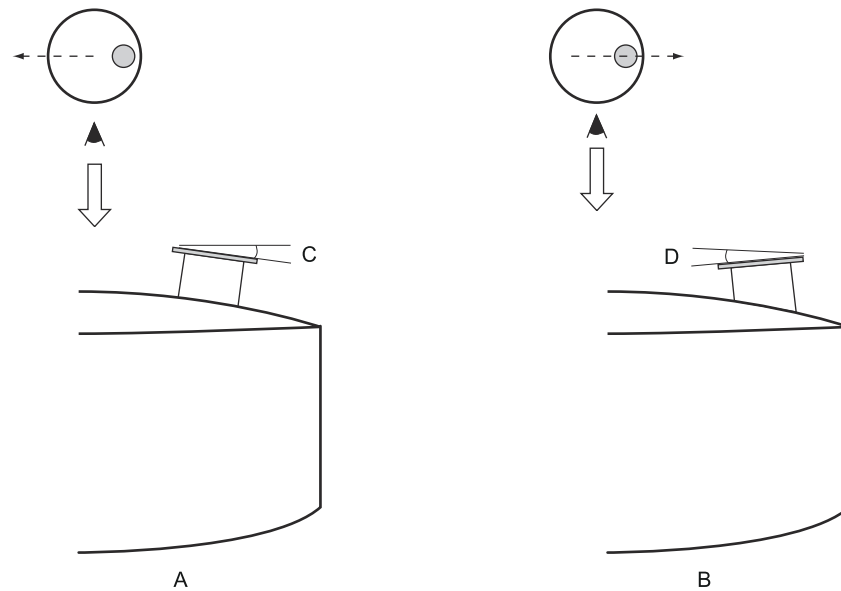

- A. Maximum inclination towards tank center
- B. Maximum inclination towards tank wall
- C. 4.5° max
- D. 2.0° max

In case the tank flange does not meet the requirements as illustrated in [Figure 3-4](#), the inclination requirements for the Parabolic Antenna can still be met by using the welded Flange Ball. The Flange Ball can be mounted at a maximum angle of 17° to the flange as illustrated in [Figure 3-5](#):

Figure 3-5: Maximum Inclination with Welded Flange

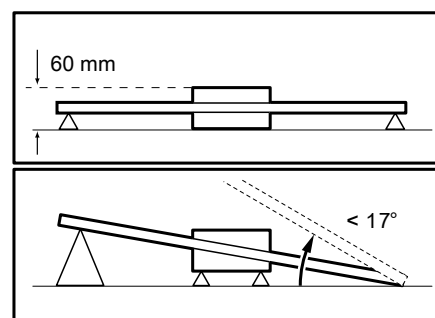

Nozzle requirements

When installing the Rosemount 5900S with Parabolic Antenna on a 20 inch nozzle, the nozzle height must not exceed 600 mm (24 in.). There has to be a free passage for the radar beam within a 5° angle from the edge of the parabolic reflector to the lower end of the nozzle.

The Rosemount 5900S should be installed so that the distance between flange and product surface exceeds 800 mm (31 in.). Highest accuracy is obtained for product levels below this point.

Nozzles with larger diameter may be higher than 600 mm (24 in.) as long as the requirement of 5° free passage is fulfilled.

Figure 3-6: Nozzle Requirements for the Rosemount 5900S with Parabolic Antenna

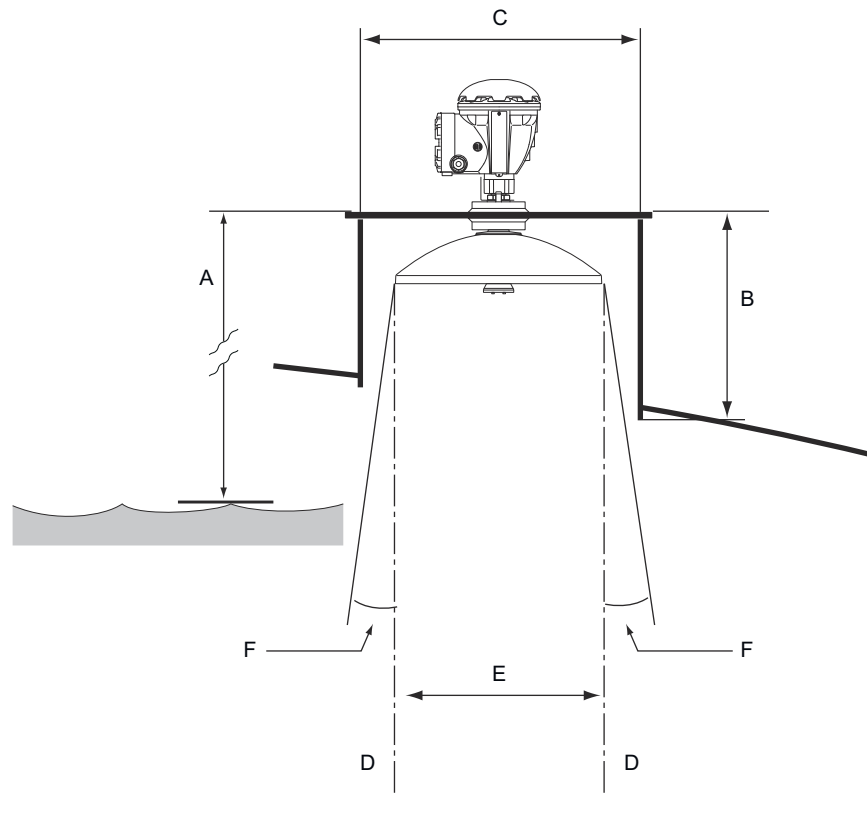

- A. Minimum 800 mm (31 in.) for highest accuracy. Minimum 500 mm (20 in.) with reduced accuracy.
- B. Recommended height: 400 mm (16 in.). Maximum height: 600 mm (24 in.).
- C. Minimum nozzle diameter: 500 mm (20 inch.)
- D. Vertical plumb line
- E. Ø 440 mm (17.3 in.)
- F. 5° minimum

Free space requirements

The radar beam of the Rosemount 5900S with Parabolic Antenna is 10° wide. Obstacles (construction bars, pipes larger than Ø 2", etc.) within the radar beam are generally not accepted, as these may result in disturbing echoes. However, in most cases, a smooth tank wall or small objects will not have any significant influence on the radar beam.

The antenna axis should be located at least 800 mm (31 in.) from the tank wall for best performance. For evaluation contact Emerson Automation Solutions/ Rosemount Tank Gauging.

Figure 3-7: Free Space Requirements for the Rosemount 5900S with Parabolic Antenna

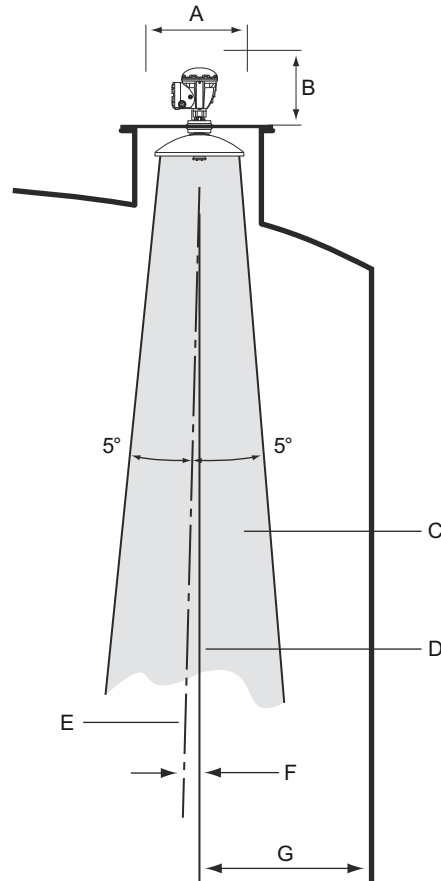

- A. Recommended space 550 mm (22 in.) for installation and service
- B. Recommended space 500 mm (20 in.) for installation and service
- C. Free passage
- D. Vertical plumb line
- E. Antenna axis
- F. Max. 1.5°
- G. Min. 0.8 m (31 in.)

3.2.3 Still Pipe antenna requirements

The Rosemount 5900S is designed for still-pipe mounting and can be mounted on existing still-pipe flanges without taking the tank out of operation. The Rosemount 5900S Still-pipe Array Antenna is available for pipe size 5, 6, 8, 10 and 12 inch.

There are two versions available in order to suit various requirements for easy installation and maintenance:

- The Rosemount 5900S Still Pipe Array antenna **Fix** version which has a flange for easy mounting when there is no need for opening the Still Pipe for hand dipping
- The Rosemount 5900S Still Pipe Array antenna **Hatch** version suitable for still-pipes that need to be opened for hand dipping

Still-pipe requirements

The Rosemount 5900S Still-pipe Array Antenna fits 5, 6, 8, 10 and 12 inch flanges and pipes. The adaptation is accomplished by selecting a suitable Still-pipe Array Antenna.

The still-pipe must be vertical⁽³⁾ within 0.5° (0.2 m over 20 m).

Table 3-3 shows the wide range of schedules and pipe inner diameters that the Array antennas can be mounted in.

Table 3-3: Antenna Size and Appropriate Pipe Inner Diameter

Antenna size (inch)	Antenna dimension (mm)	Suitable for pipe dimension	
		Size	Inner diameter (mm)
5	120.2	SCH10-SCH60	125.3 - 134.5
6	145.2	SCH10-SCH60	150.3 - 161.5
8	189	SCH20-SCH80	193.7 - 206.3
10	243	SCH10-SCH60	247.7 - 264.7
12	293.5	SCH 10-40-XS	298.5 - 314.7

⁽³⁾ Please contact Emerson / Rosemount Tank Gauging for advice if this requirement can not be met.

Flange requirements

The Rosemount 5900S with Still-pipe Array Antenna fits flanges of size 5, 6, 8, 10 and 12 inch. The gauge has a flange for sealing the tank. The tank flange must be horizontal within $\pm 2^\circ$.

Figure 3-8: The Flange Must Be Horizontal Within $\pm 2^\circ$

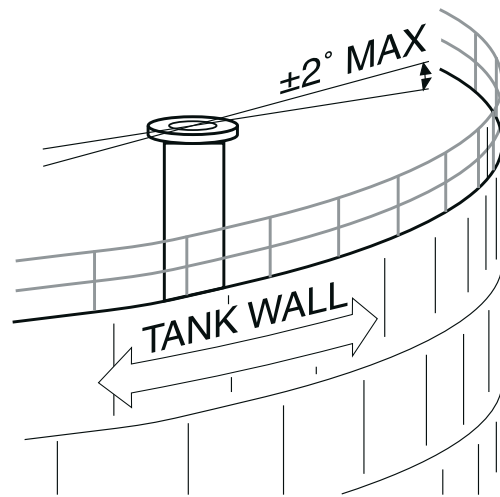

Recommended installation

When designing new tanks, an 8 inch still-pipe or larger is recommended. This is particularly important in tanks with sticky and viscous products. See drawing D9240041-917 “Recommended still-pipes” for more information on recommended still-pipes for the Rosemount 5900S. Before manufacturing a new still-pipe, we recommend that you contact Emerson Automation Solutions / Rosemount Tank Gauging for advice.

For highest performance, the total area of the slots or holes in the still-pipe must not exceed the values shown in [Table 3-4](#) below. The listed values refer to the total area of the holes over the entire length of the pipe, regardless of its length. In some cases it is possible to allow a larger total area than stated in [Table 3-4](#). When the limits are exceeded, please contact Emerson Automation Solutions / Rosemount Tank Gauging for advice.

Table 3-4: Maximum Area of Slots and Holes

Pipe Dimension (inch)	Max. Area of Slots and Holes (m ²)
5	0.1
6	0.1
8	0.4
10	0.8
12	1.2

Free space

The following free space is recommended for mounting the Rosemount 5900S with Still-pipe Array Antenna:

Figure 3-9: Free Space Requirements for Rosemount 5900S with Array Antenna Fix Version

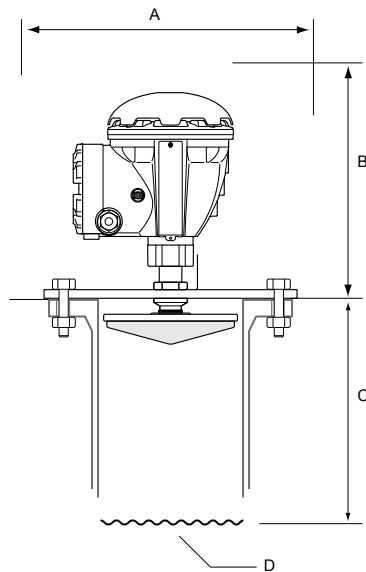

Table 3-5: Free Space Requirements

Position	Free Space
A	Recommended space 550 mm (22 in.) for installation and service
B	Recommended space 500 mm (20 in.) for installation and service
C	Minimum 800 mm (31 in.) for highest accuracy Minimum 500 mm (20 in.) with reduced accuracy
D	Product surface

Figure 3-10: Free Space Requirements for Rosemount 5900S with Array Antenna Hatch Version

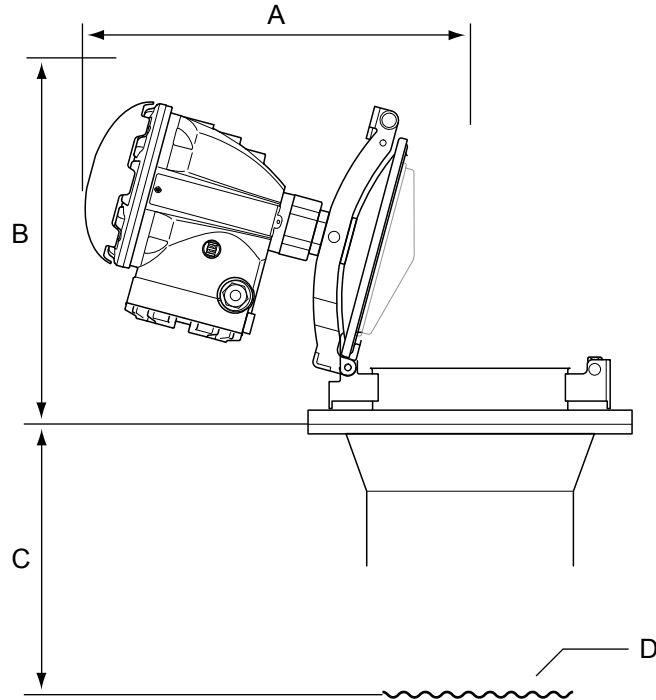

Table 3-6: Free Space

Position	Free Space
A	See Table 3-7
B	Recommended space 500 mm (20 in.) for installation and service
C	Minimum 800 mm (31 in.) for highest accuracy Minimum 500 mm (20 in.) with reduced accuracy
D	Product surface

Table 3-7: Free Space (A) for Opening the Hatch

Antenna Size (inch)	Space (A) (mm/in.)
5	470/18.5
6	470/18.5
8	480/18.9
10	490/19.3
12	490/19.3

3.2.4 LPG/LNG antenna requirements

Temperature and pressure measurement

Measurements of temperature and pressure is a prerequisite for high accuracy level measurements in LPG/LNG tanks. A Rosemount Tank Gauging system may include Rosemount 5900S Radar Level Gauges, Rosemount 2240S Multi-input Temperature Transmitters, Rosemount 644 Temperature Transmitters as well as pressure transmitters in order to obtain all necessary measurement variables.

Still-pipe and Verification Pin

A still-pipe must be installed prior to the gauge installation. The still-pipe is customer supplied and should be manufactured according to the installation drawings.

Three types of steel pipe are recommended:

- DN100
- 4 inch SCH 10 stainless steel pipe
- 4 inch SCH 40 stainless steel pipe

When ordering the level gauge specify the pipe type in the Required System Information (RSI) form.

The still-pipe must be vertical within $\pm 0.5^\circ$ and the customer flange must be horizontal within $\pm 1^\circ$ as illustrated in [Figure 3-11](#).

The still-pipe is manufactured with a number of holes to allow proper circulation of the product, and to ensure equalization of product density inside and outside the pipe. The hole diameter should be 20 mm or 3/4". All holes in the upper still-pipe section must be placed along a line on one side of the pipe.

The Verification Pin allows you to verify Rosemount 5900S level measurements when the tank is pressurized. It is mounted on the still-pipe in a hole oriented 90 degrees to the other holes.

The Verification Pin should be placed at a position of 1200 mm (47 in.) below the flange as illustrated in [Figure 3-11](#). There must be a minimum distance of 200 mm (8 in.) between the Verification Pin and the maximum product level. In order to fulfill this requirement, the Verification Pin may be mounted higher, up to 1000 mm below the flange.

The Verification Pin must be aligned with a bolt hole on the still-pipe flange as illustrated in [Figure 3-11](#). The Verification Pin's position must be clearly marked on the still-pipe flange (see [Figure 3-11](#)) to allow proper alignment of the Rosemount 5900S gauge.

See installation drawing D9240 041-910 for LPG/LNG Still-pipe for information on how to install the Verification Pin on the still-pipe. Installation instructions are enclosed with the Verification Pin and Deflection Plate.

See [LPG configuration](#) and see the Rosemount Tank Gauging System [Configuration Manual](#) for further information on how to configure the Rosemount 5900S for LPG/LNG measurements.

Figure 3-11: Installation of Verification Pin and Inclination Requirements for Flange and Still-pipe

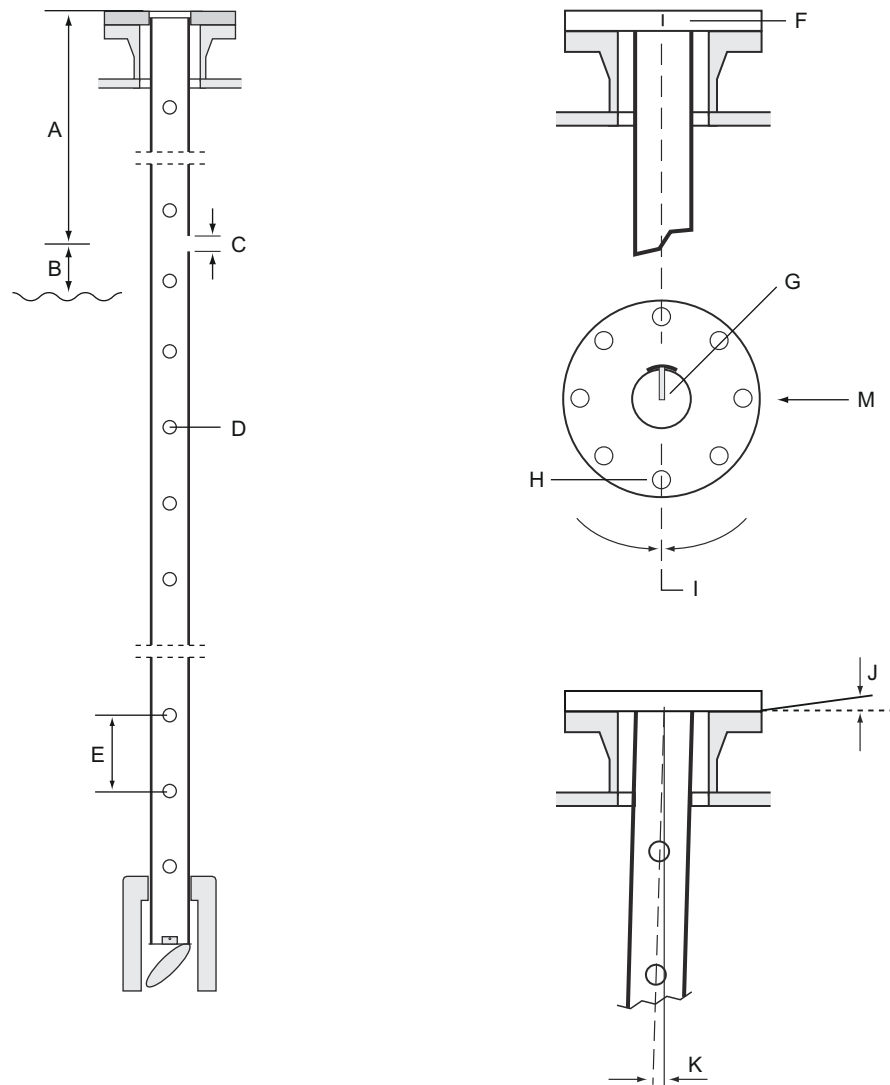

- | | |
|---|---|
| A. 1000 <math>< L < 2500</math> mm (39 <math>< L < 98</math> in.).
Recommended: 1200 mm (47 in.) | G. The Verification Pin is directed towards the bolt hole at the pipe flange marking. |
| B. Min. 200 mm (8 in.) from Verification pin to product | H. Bolt hole |
| C. Hole for Verification Pin; \varnothing 20 mm. | I. Align Verification Pin and bolt hole within 1°. |
| D. Holes for density equalization; \varnothing 20 mm (3/4 in.) | J. Maximum 1° |
| E. 500 mm (20 in.) | K. Maximum 0.5° |
| F. Mark on still-pipe flange | |

Deflection plate with calibration ring

A Deflection Plate is mounted at the lower end of the still-pipe and is integrated with a ring that is used for calibrating the gauge during the installation phase when the tank is empty. Installation instructions are enclosed with the Verification Pin and Deflection Plate.

Figure 3-12: Still-pipe with Deflection Plate and Verification Pin

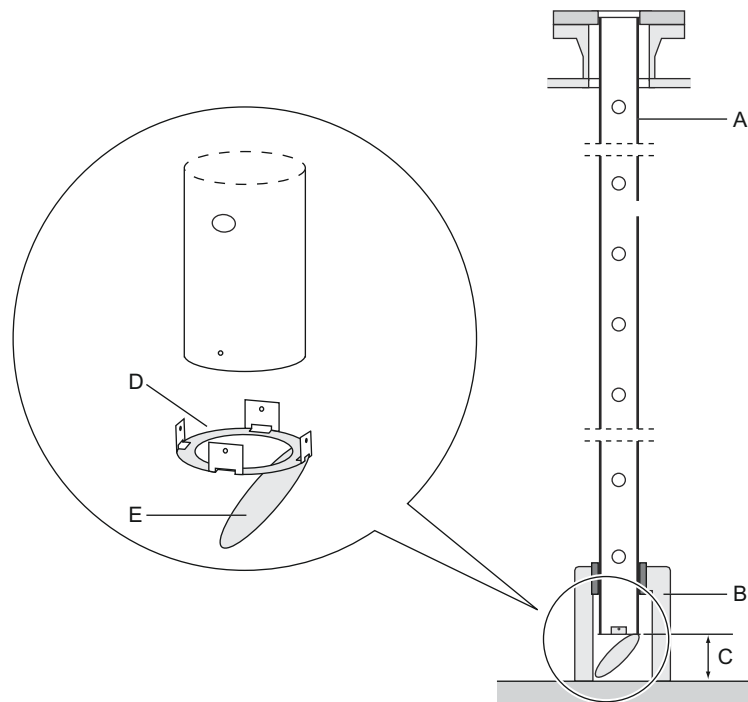

- A. Still-pipe
- B. Support
- C. Minimum 150 mm (6 in.)
- D. Calibration ring
- E. Deflection plate

The Deflection Plate can be attached to the still-pipe by using one of three methods:

- Welding
- M4 screw and nut
- Riveting

For pipe dimensions 4 inch SCH 40 and DN 100, an extra ring is needed for the Deflection Plate as illustrated in [Figure 3-13](#) and [Figure 3-14](#).

See [LPG configuration](#) and the Rosemount Tank Gauging [System Configuration Manual](#) for further information on how to configure the Rosemount 5900S for LPG/LNG measurements.

Figure 3-13: Mounting the Deflection Plate on Pipe 4 inch SCH 40

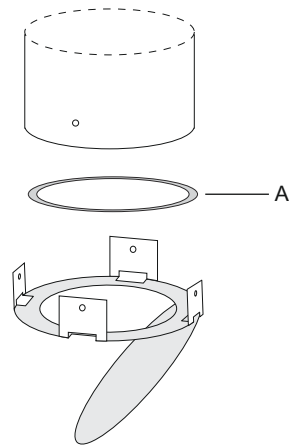

A. Ring is marked 4" SCH40

Figure 3-14: Mounting the Deflection Plate on Pipe DN 100

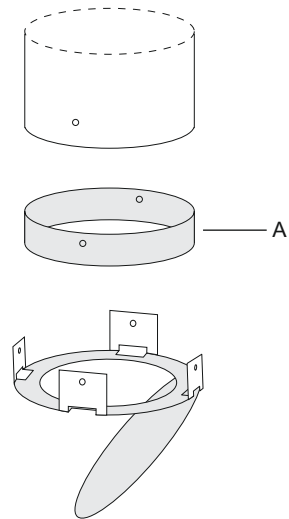

A. Ring is marked DN100

Free space

The following free space is recommended for mounting the Rosemount 5900S with LPG/LNG Antenna:

Figure 3-15: Free Space Requirements for Rosemount 5900S with LPG/LNG antenna

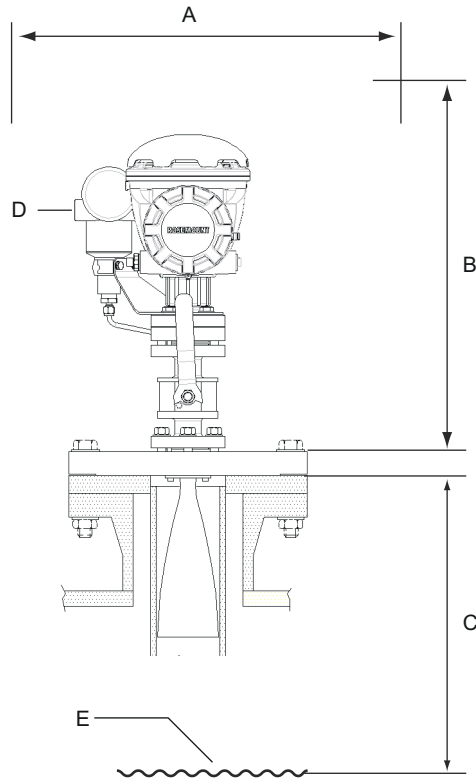

- A. Recommended space 550 mm (22 in.) for installation and service
- B. Recommended space 1000 mm (39 in.) for installation and service
- C. Minimum 1200 mm (47 in.) to product surface for highest accuracy. Minimum 800 mm (31 in.) with reduced accuracy
- D. Optional pressure transmitter
- E. Product surface

Extension pipe for minimum distance

The Rosemount 5900S Radar Level Gauge should be placed such that there is a minimum gap of 1200 mm (47 in.) between the flange and the maximum product level (see [Still-pipe and Verification Pin](#)). If necessary, an extension pipe can be used to raise the level gauge. This will allow measurements closer to the top of the tank than would otherwise be possible, as illustrated in [Figure 3-16](#).

Figure 3-16: Rosemount 5900S with Extension Pipe

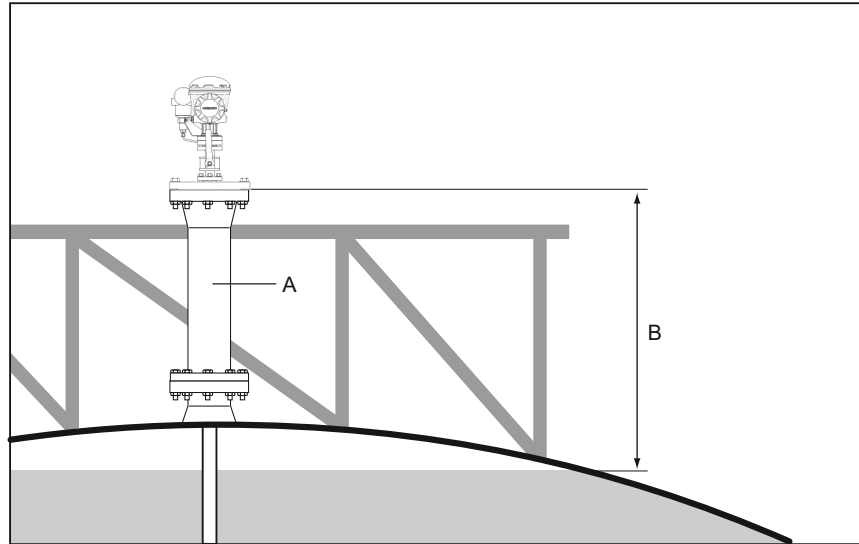

- A. Extension pipe
- B. Minimum 1200 mm (47 in.) to product surface

3.3 Mechanical installation

3.3.1 Mounting the Horn antenna

This section describes how to install the Rosemount 5900S with with Horn Antenna.

Follow this instruction to install the Horn antenna and transmitter head assembly on a tank.

Prerequisites

- Check that all parts and tools are available before carrying them up to the tank roof.
- See [Horn antenna requirements](#) for information on mounting considerations before installing the gauge on the tank.

Procedure

1. Put a gasket on the socket and carefully insert the horn antenna and flange assembly.

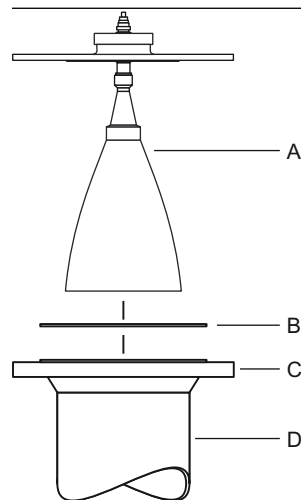

- A. Horn antenna and flange assembly
- B. Gasket (Customer supplied)
- C. Customer supplied flange
- D. Nozzle

2. Tighten the flange with required torque depending on gasket and flange type by using suitable screws and nuts (customer supplied).

- Put the adapter on the flange. The groove on the adapter should be directed approximately 90° to the line of sight from the nozzle to the center of the tank.

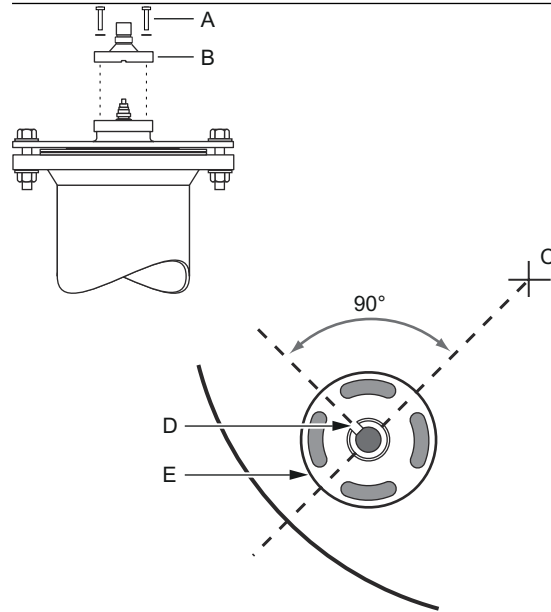

- A. Four M10 screws and washers
- B. Adapter
- C. Tank center
- D. Groove
- E. Adapter

- Tighten the four M10 screws with washers by hand so that the adapter can be rotated.
- Put the transmitter head onto the antenna adapter.

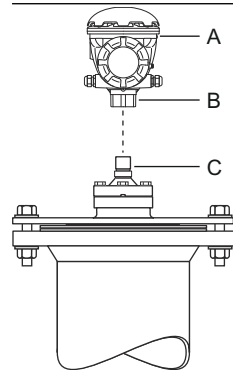

- A. Transmitter head
- B. Nut
- C. Adapter

- Ensure that the guide pin inside the transmitter head fits the groove on the adapter.

7. Tighten the nut that connects the transmitter head to the adapter.
8. Align the level gauge by using the cross hairs on top of the transmitter head.

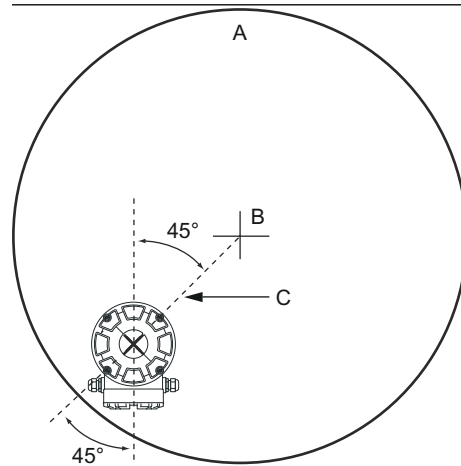

- A. Tank
- B. Tank center
- C. Line of sight

9. In case the weather protection hood is attached, the gauge can be aligned by using a line of sight along the screws on top of the head.
10. Ensure that the gauge is directed at an angle of 45° to the line of sight from the center of the tank to the nozzle.
11. Tighten the adapter screws ($4 \times M10$).
12. In case the Weather Protection Hood was removed, put it back on top of the head and tighten the screw.

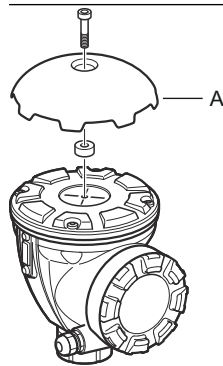

- A. Weather Protection Hood

13. Wire the gauge and configure by using the Rosemount TankMaster WinSetup software (see the Rosemount Tank Gauging [System Configuration Manual](#)).

3.3.2 Parabolic antenna

Mounting the clamped Flange Ball

Follow this instruction when installing the clamped Flange Ball on a flange.

Prerequisites

1. Use a flange of thickness 6 - 30 mm.
2. Make sure that the diameter of the hole is 96 mm. Make a small recess at one side of the flange hole.

Figure 3-17: Flange Requirements

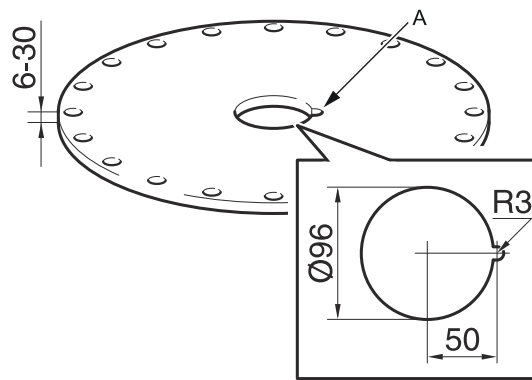

A. Recess

Procedure

1. Put the O-ring on the flange and insert the Flange Ball into the hole. Make sure that the guide pin on the side of the Flange Ball fits into the recess on the flange.

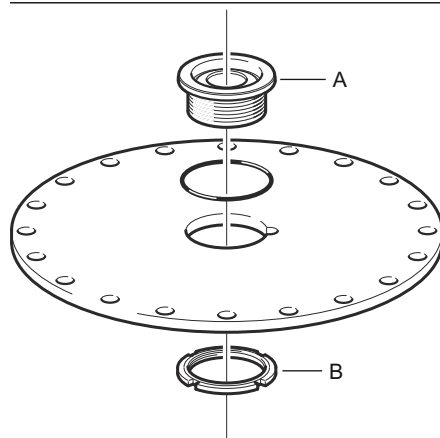

A. Flange Ball
B. Nut

2. Tighten the nut so that the Flange Ball fits tightly to the flange (torque 50 Nm).

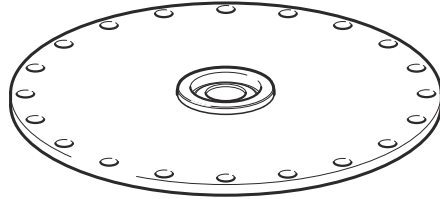

Mounting the welded Flange Ball

Follow this instruction when installing the welded Flange Ball on a flange.

Prerequisites

For horizontal mounting according to requirements in chapter [Parabolic antenna requirements](#), make sure that the diameter of the hole is 116 ± 2 mm.

Figure 3-18: Flange Requirements

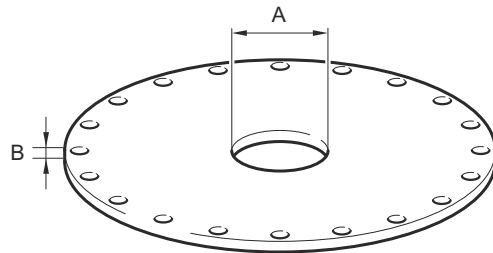

- A. 116 ± 2 mm
- B. 6-38 mm

In case the flange requirements in chapter [Parabolic antenna requirements](#) are not met, the hole needs to be machined to an oval shape prepared for inclined welding of the Flange Ball.

Procedure

1. Let the protection plates remain on the Flange Ball until welding is finished. These plates protect the surface of the Flange Ball from welding sparks.

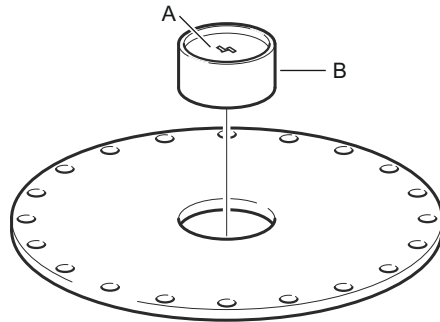

A. Protection plate
B. Flange Ball

2. Make sure that the Flange Ball is mounted in such a way that the groove is directed upwards when the flange is mounted on the tank nozzle.

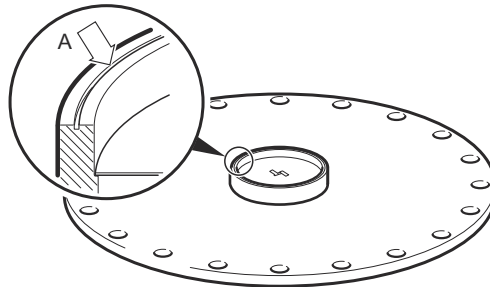

A. Groove

3. If the tank flange is inclined, make sure that the Flange Ball is welded so that the Flange Ball is horizontal when it is mounted on the tank. The tank flange inclination should not exceed 17 degrees.

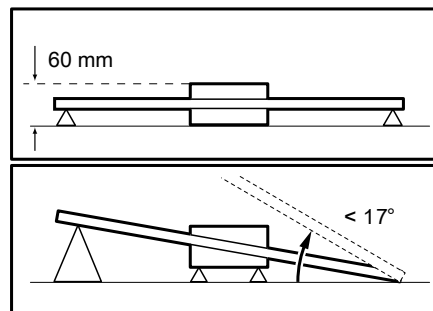

4. Remove the protection plates when the Flange Ball is welded to the flange.

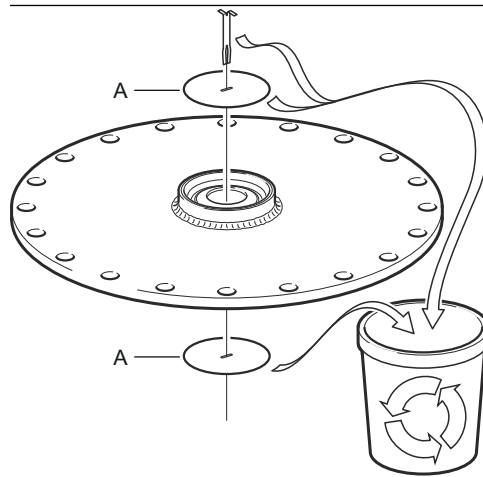

A. Protection plate

Mounting the parabolic antenna

This section describes how to install the Rosemount 5900S with Parabolic antenna.

Follow this instruction to install the Parabolic antenna and transmitter head assembly on a tank.

Prerequisites

- See [Parabolic antenna requirements](#) for considerations before installing the gauge on the tank.
- Check that all parts and tools are available before carrying them up to the tank top.

Procedure

1. Fit the Parabolic Reflector onto the Antenna Feeder and tighten the five M5 screws.

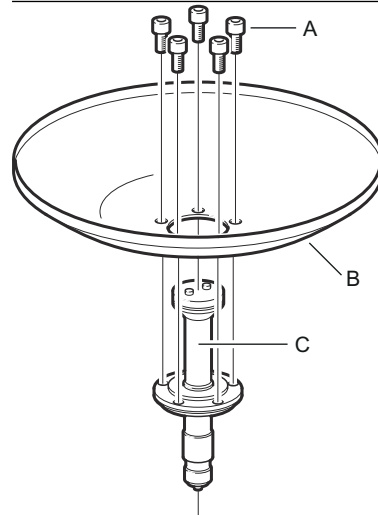

- A. M5x5
- B. Parabolic Reflector
- C. Antenna Feeder

2. Tighten the screws.

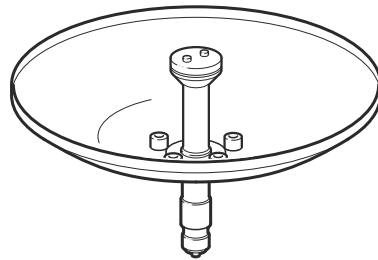

3. Put the two O-rings in the grooves on the upper surface of the Flange Ball.
-

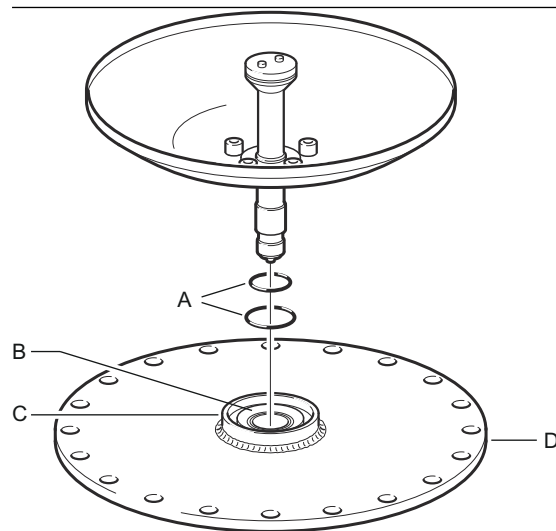

- A. 2 O-rings
 - B. Grooves
 - C. Flange Ball
 - D. Flange
-

4. Turn the flange around and insert the Antenna Waveguide into the flange hole.

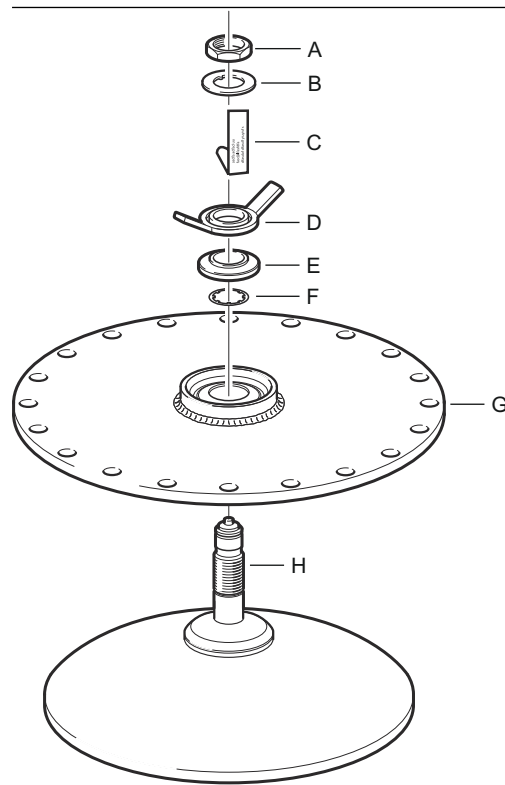

- A. Nut
- B. Tab Washer
- C. Antenna label plate
- D. Finger Nut
- E. Washer Ball
- F. Stop Washer
- G. Flange
- H. Antenna Waveguide

5. Mount the washers and nuts.

Note that the purpose of the Stop Washer is to prevent the antenna from falling down into the tank. Therefore it fits tightly to the Antenna Waveguide.

6. Tighten the finger nut and the upper nut by hand.

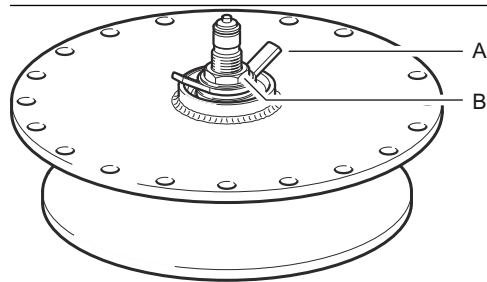

- A. Finger Nut
B. Upper Nut
-

7. Place the antenna and flange assembly on the tank nozzle and tighten the flange screws.

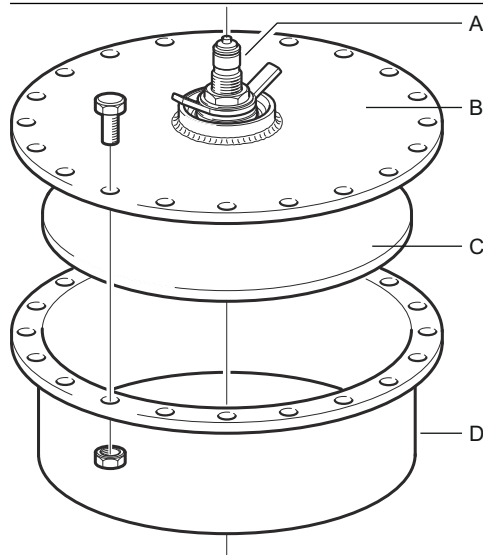

- A. Antenna Waveguide
B. Flange
C. Antenna
D. Nozzle
-

- Put the level gauge on the Antenna Waveguide. Ensure that the guide pin inside the transmitter head fits into the groove on the Antenna Waveguide.

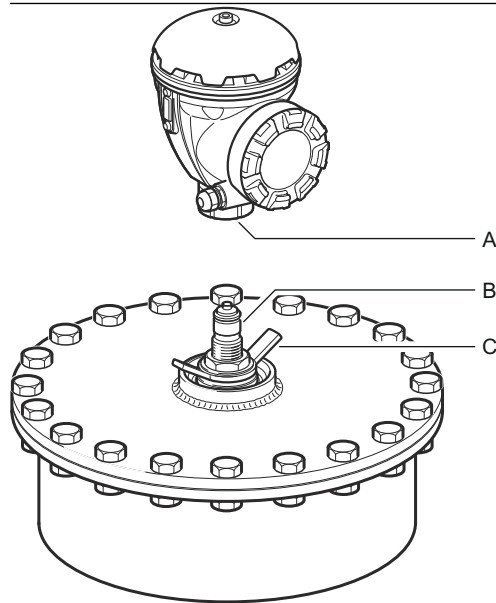

- A. Nut
- B. Antenna Waveguide
- C. Finger Nut

-
- Tighten the nut that connects the transmitter head to the antenna.
 - Loosen the finger nut slightly.

11. Align the level gauge by using the cross hairs on top of the transmitter head.
In case the weather protection hood is attached, the gauge can be aligned by using a line of sight along the screws on top of the head.
-

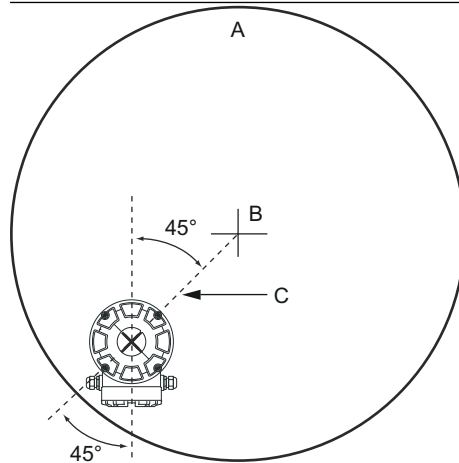

- A. Tank
B. Tank center
C. Line of sight
-

12. Ensure that the gauge is directed at an angle of 45° to the line of sight from the center of the tank to the wall.

13. Use the marks on the Washer Ball to adjust the gauge so the antenna is inclined roughly 1.5° towards the center of the tank.

Note

For products with high condensation, such as bitumen, the gauge should be mounted with 0° inclination in order to achieve maximum signal strength.

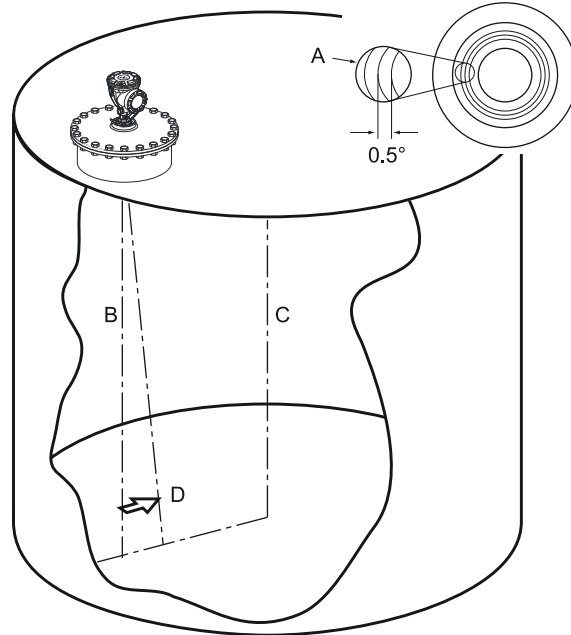

- A. Marks
 - B. Plumb line
 - C. Tank center
 - D. Incline antenna 1.5° towards tank center
-

14. Tighten the finger nut.

15. You may use a level (optional) to verify correct inclination of 1.5° towards the tank center. Ensure that the level is put on a flat and steady surface on top of the transmitter head. If needed, loosen the finger nut and adjust the gauge.

Note

Make sure the air bubble touches, but doesn't overlap the 1.5° mark.

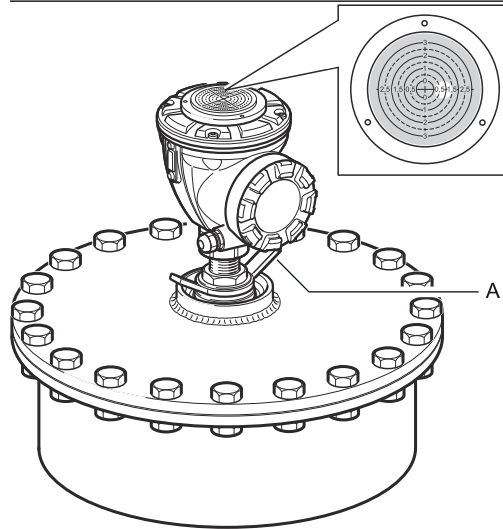

A. Finger Nut

16. Tighten the finger nut firmly.

17. In case the Weather Protection Hood was removed, put it back on top of the transmitter head and tighten the screw.

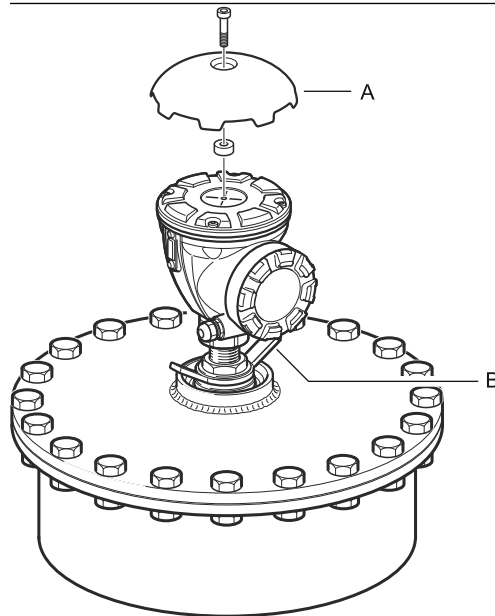

A. Weather Protection Hood
B. Finger Nut

18. Tighten the upper nut to lock the finger nut (you may temporarily remove the transmitter head to make room for tools if needed), and secure by folding the tab washer over the nut.

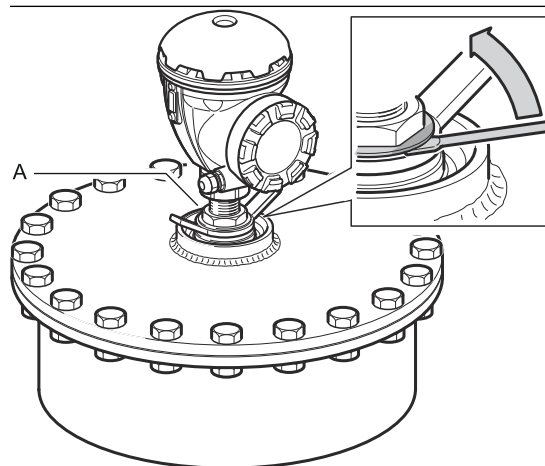

A. Upper Nut

19. Wire the gauge and configure by using the RosemountTankMaster WinSetup software (see the Rosemount Tank Gauging [System Configuration Manual](#)).

3.3.3 Array antenna - fix version

Prerequisites

See [Still Pipe antenna requirements](#) for information on mounting considerations before installing the gauge on the tank.

Measure the pipe inner diameter before closing the still-pipe. Enter this value during the configuration.

Follow this instruction when installing the Rosemount 5900S with Array Antenna Fixed version.

Procedure

1. Insert the Antenna Waveguide into the flange hole, and place the antenna label into position, with text down.

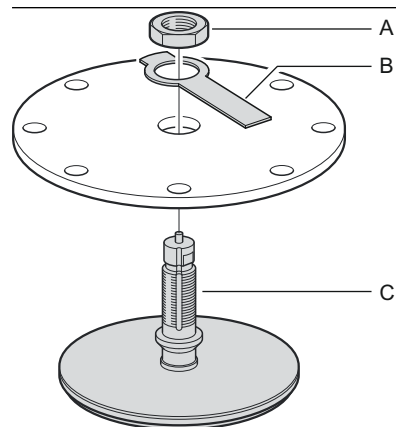

- A. Nut
- B. Antenna label plate
- C. Antenna Waveguide

2. Tighten the nut.

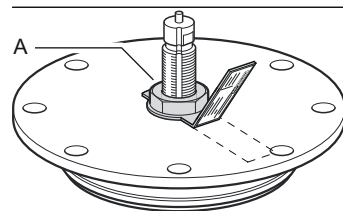

- A. Nut

3. Secure the nut by folding the tab on the label plate over the nut.
4. Bend the antenna label plate at the slot mark to a position with the text clearly visible.

5. Put the antenna and flange assembly on the tank nozzle and tighten the flange screws.

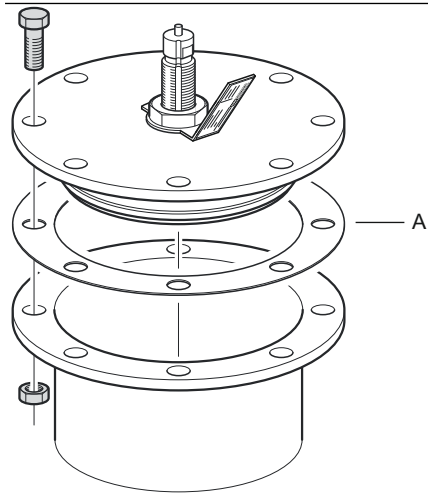

A. Gasket

6. Carefully put the gauge on top of the Antenna Waveguide and tighten the nut. Ensure that the guide pin inside the transmitter head fits the groove on the Waveguide.

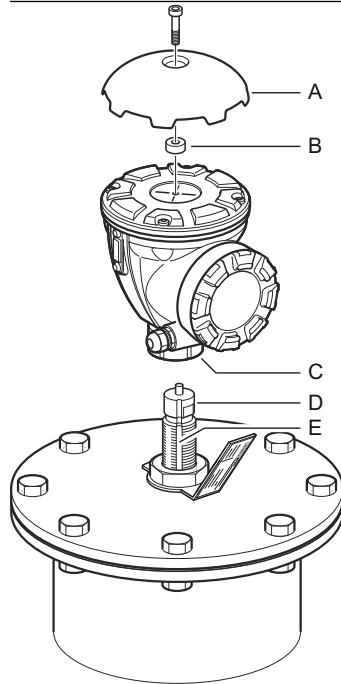

- A. Weather Protection Hood
- B. Spacer
- C. Nut
- D. Antenna Waveguide
- E. Groove

7. In case the Weather Protection Hood was removed, put it back on top of the transmitter head and tighten the screw.
8. Wire the gauge and configure by using the Rosemount TankMaster WinSetup software, (see the Rosemount Tank Gauging [System Configuration Manual](#)).

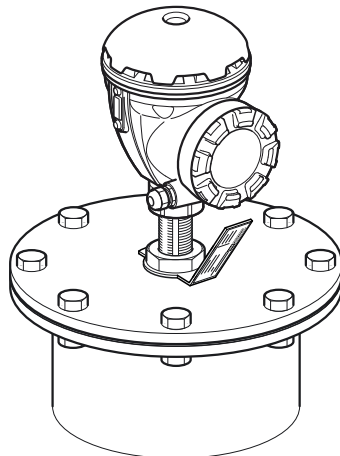

3.3.4 Array antenna - hinged hatch

Prerequisites

See [Still Pipe antenna requirements](#) for information on mounting considerations before installing the gauge on the tank.

Follow this instruction when installing the Rosemount 5900S with Array Antenna Hinged Hatch version.

Procedure

1. Mount the hatch on the nozzle. The hatch has a welded flange with a hole pattern that fits the nozzle flange.

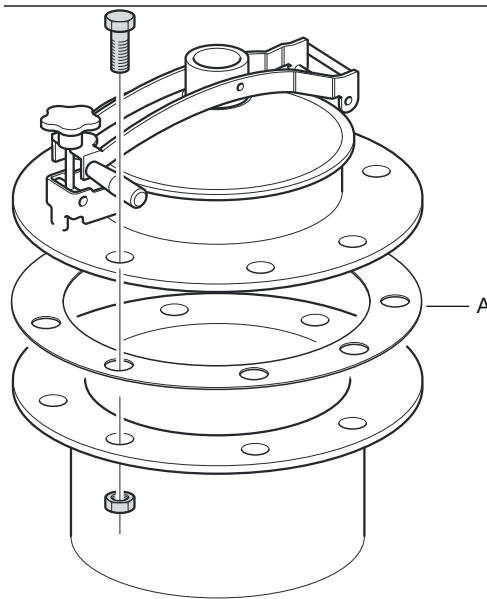

A. Gasket

2. Tighten the flange screws. The smaller hatches may have a couple of pin bolts in addition to the screws.

3. Mount the antenna on the lid. Ensure that the guide pin inside the lid fits the groove on the Antenna Waveguide.

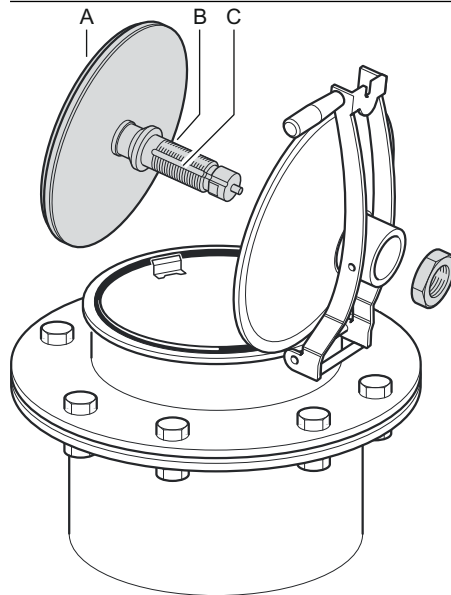

- A. Antenna
- B. Antenna Waveguide
- C. Groove

4. Tighten the nut which holds the antenna to the lid.

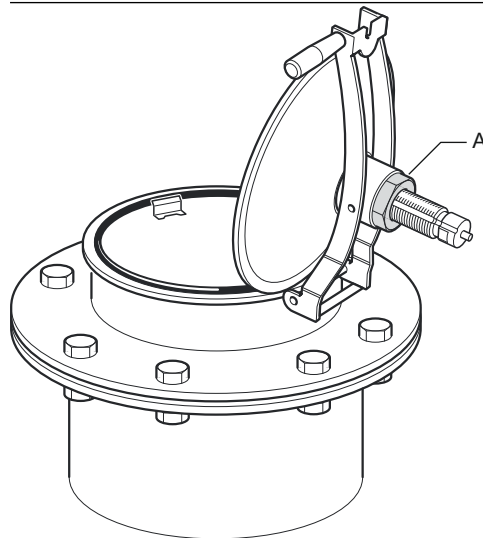

- A. Nut

5. Check that the O-ring is properly seated all around the cover and is pressed down behind the Hand Dip Plate.

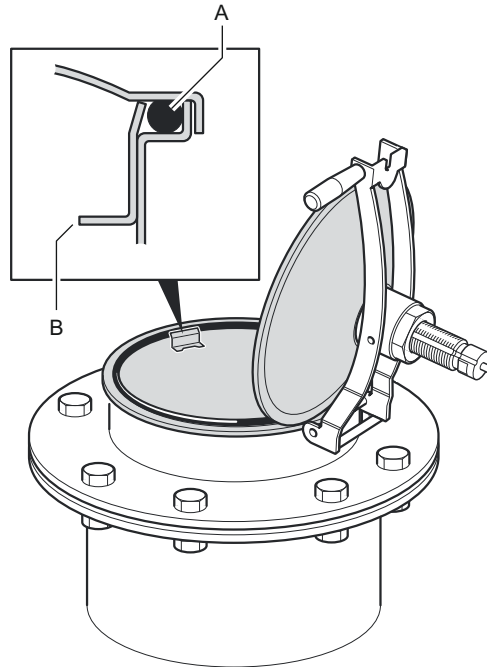

- A. O-ring
- B. Hand Dip Plate

6. Close the lid and tighten the locking screw.

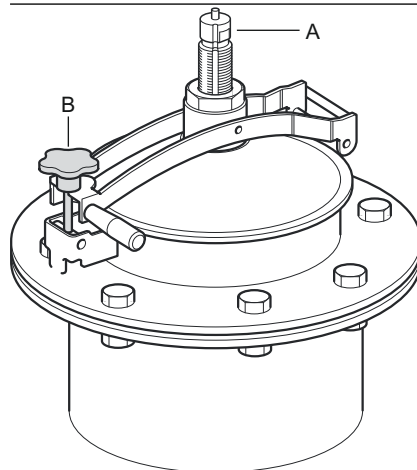

- A. Antenna Waveguide
- B. Tighten the locking screw

7. Carefully put the gauge on top of the Antenna Waveguide and tighten the nut. Ensure that the guide pin inside the transmitter head fits the groove on the Antenna Waveguide.

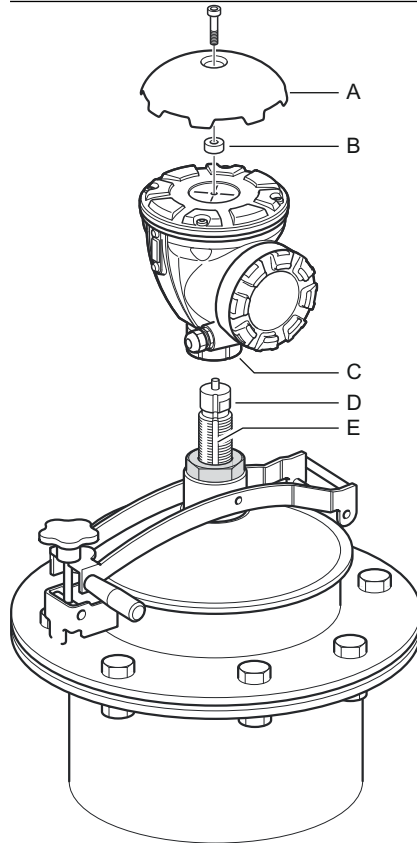

- A. Weather Protection Hood
- B. Spacer
- C. Nut
- D. Antenna Waveguide
- E. Groove

8. In case the Weather Protection Hood was removed, put it back on top of the transmitter head and tighten the screw.

9. Wire the gauge and configure by using the Rosemount TankMaster WinSetup software (see the Rosemount Tank Gauging [System Configuration Manual](#)).

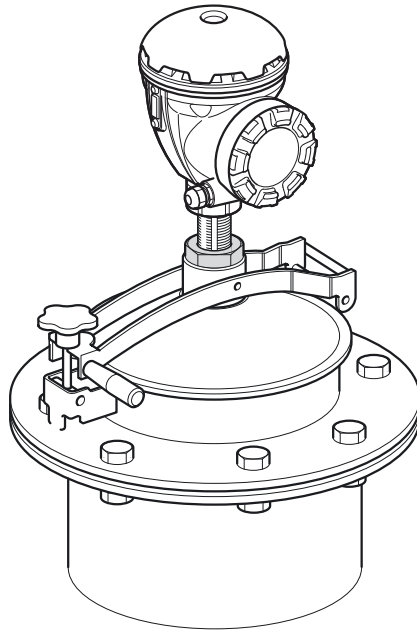

3.3.5 LPG/LNG antenna

Prerequisites

Ensure that all parts and tools are available before carrying them to the tank top.

Note

There must be a mark on the still-pipe flange to show the direction of the Verification Pin. Carefully check that the closing is aligned to the mark on the still-pipe flange as described below.

See [LPG/LNG antenna requirements](#) for information on mounting considerations before installing the gauge on the tank.

Follow this step by step instruction when installing the LPG/LNG antenna.

Procedure

1. Install the still-pipe according to mechanical installation drawing 9240041-910.
2. Check that the cone antenna fits into the still-pipe. The gap between the cone antenna and the pipe must not exceed 2 mm.

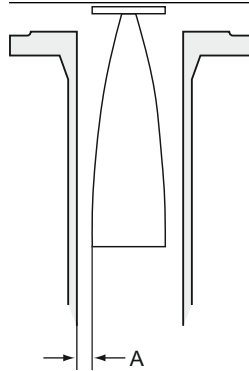

A. Maximum 2 mm

3. Mount the antenna on the closing using four M6 Allen head screws. Be careful when handling the closing and antenna assembly. It is important that the antenna is undamaged without dents.

Let the protection cap remain on the waveguide until the antenna is installed.

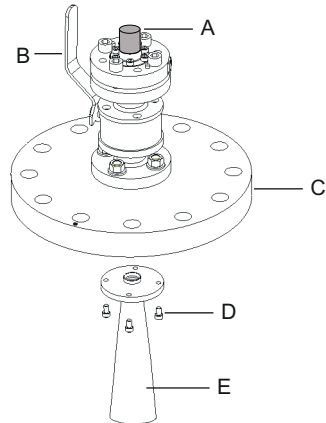

- A. Protection cap
- B. Ball valve
- C. Closing
- D. Four M6 screws
- E. Antenna

4. Place a gasket (customer supplied) on the still-pipe flange.

- Carefully fit the antenna into the still-pipe.

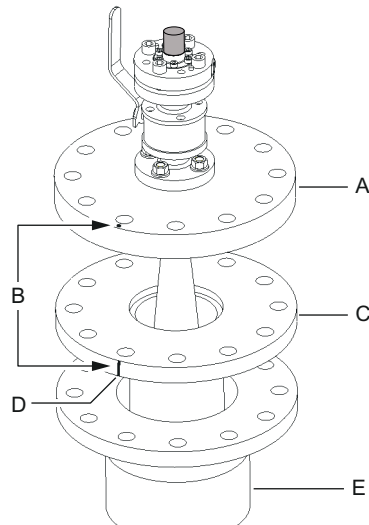

- A. Closing
- B. Align mark with notch on the pipe flange
- C. Still-pipe flange
- D. Notch that indicates direction of the Verification Pin
- E. Nozzle

- Direct the closing so that the mark aligns with the notch on the pipe flange.
- Tighten the closing onto the still-pipe flange (customer supplied screws and nuts).
The tank is now sealed and can, as far as Rosemount Tank Gauging equipment is concerned, be pressurized.

Note

For a safe installation on a pressurized tank it is important that the gauge is installed in accordance with the appropriate local, national, and international standards, codes, and practices.

- Remove the protection cap from the waveguide.

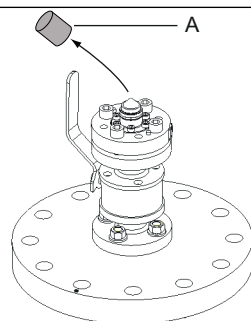

- A. Protection cap

- Put the adapter on the flange.
Ensure that the guide pins on the flange fit the holes at the bottom of the adapter.

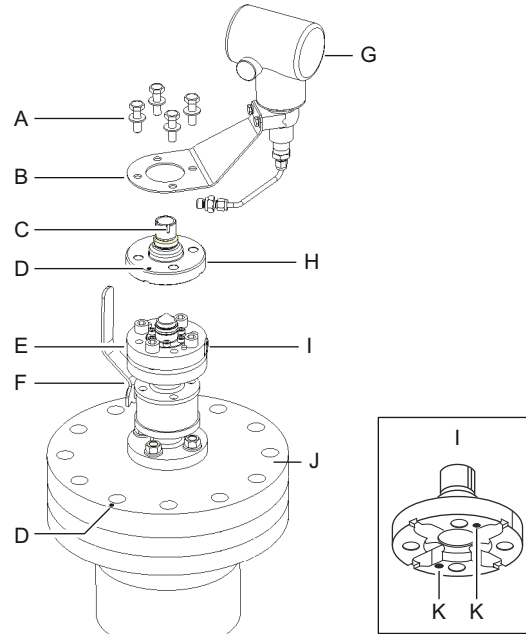

- A. Four M10 screws
- B. Bracket
- C. Groove
- D. Mark
- E. Flange
- F. Ball valve
- G. Pressure transmitter
- H. Adapter
- I. Entry for pressure transmitter
- J. Closing
- K. Holes for guide pins

- Ensure that the mark on top of the adapter aligns with the mark on the closing.
- Mount the bracket and the pressure transmitter.
- Tighten the four M10 screws with washers.
- Connect the pipe at the pressure transmitter input to the entry on the flange and tighten the nut.
- Put the Rosemount 5900S radar gauge on the adapter. Ensure that the guide pin inside the waveguide of the radar gauge fits the groove on the adapter. The direction of the Verification Pin is indicated by marks on the still-pipe flange and the closing. See [LPG/LNG antenna requirements](#) for more information.
(The second groove on the adapter is used for measurement verification when replacing a TankRadar Rex level gauge with a Rosemount 5900S).

15. Tighten the nut that connects the transmitter head to the adapter.

Note

The adapter has two grooves. Use the one that allows the transmitter head to be aligned with the Verification Pin as illustrated in [Step 16](#).

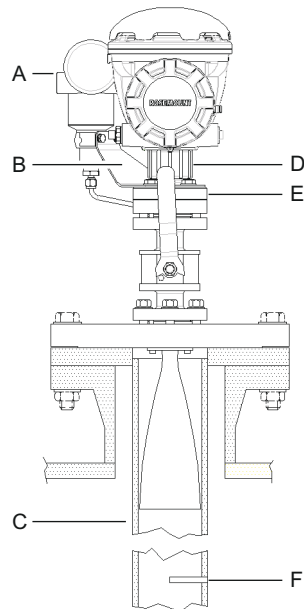

-
- A. Pressure transmitter
 - B. Bracket for pressure transmitter
 - C. Still-pipe
 - D. Nut
 - E. Adapter
 - F. Verification Pin
-

16. Verify that the level gauge head is properly aligned. The cover on the terminal compartment shall be parallel to the Verification Pin. The notch on the still-pipe flange indicates the direction of the Verification Pin.

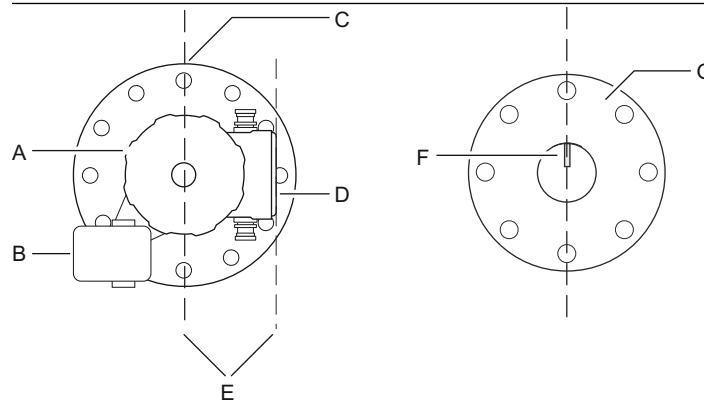

- A. Rosemount 5900 Level Gauge
- B. Pressure transmitter
- C. Mark that indicates direction of the Verification Pin
- D. Cover on the terminal compartment
- E. Parallel
- F. Verification Pin
- G. Still-pipe

17. Wire the gauge, and configure by using the Rosemount TankMaster WinSetup software as described in the Rosemount Tank Gauging [System Configuration Manual](#).
18. Configure the level gauge for LPG measurements (see [LPG configuration](#)).

3.4 Electrical installation

3.4.1 Cable/conduit entries

The electronics housing has two entries for ½ - 14 NPT. Optional M20×1.5, minifast and eurofast adapters are also available. The connections must be made in accordance with local or plant electrical codes.

Make sure that unused ports are properly sealed to prevent moisture or other contamination from entering the terminal block compartment of the electronics housing.

Note

Use the enclosed metal plugs to seal unused ports. The plastic plugs mounted at delivery are not sufficient as seal!

Note

Thread sealing (PTFE) tape or paste on male threads of conduit is required to provide a water/dust tight conduit seal and to meet the required degree of ingress protection as well as to enable future removal of the plug/gland.

NPT is a standard for tapered threads. Engage the gland with 5 to 6 threads. Note that there will be a number of threads left outside the housing as illustrated below.

Figure 3-19: Cable Entry with NPT Threaded Gland

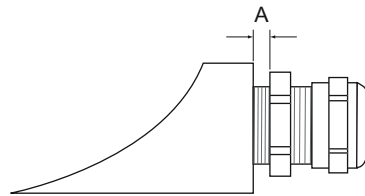

A. The NPT threaded gland leaves a number of threads outside the housing

Ensure that glands for the cable entries meet requirements for IP class 66 and 67.

3.4.2 Grounding

The housing should always be grounded in accordance with national and local electrical codes. Failure to do so may impair the protection provided by the equipment. The most effective grounding method is direct connection to earth ground with minimal impedance. There are three grounding screw connections provided. Two are located inside the terminal compartment of the housing and the third is located on the housing. The internal ground screws are identified by a ground symbol: \perp .

Note

Grounding the transmitter via threaded conduit connection may not provide sufficient ground.

Grounding - FOUNDATION™ Fieldbus

Signal wiring of the fieldbus segment can not be grounded. Grounding out one of the signal wires may shut down the entire fieldbus segment.

Shield wire ground

To protect the fieldbus segment from noise, grounding techniques for shield wire usually require a single grounding point for shield wire to avoid creating a ground loop. The ground point shall be located at the power supply.

The devices designed for “daisy-chain” connection offer an isolated shield loop-through terminal in order to enable a continuous shield throughout the Tankbus network.

In order to avoid unintentional grounding points, the cable shield inside the terminal compartment must be isolated.

3.4.3 Cable selection for the Tankbus

Use shielded twisted pair wiring for the Rosemount 5900S Series in order to comply with FISCO⁽⁴⁾ requirements and EMC regulations. The preferred cable is referred to as type “A” fieldbus cable. The cables must be suitable for the supply voltage and approved for use in hazardous areas, where applicable. In the U.S. explosion-proof conduits may be used in the vicinity of the vessel.

Use wire rated at least 5 °C above maximum ambient temperature.

We recommend cable size 1.0 mm² or 18 AWG in order to facilitate wiring. However, cables within the range 0.5 to 1.5 mm² or 20 to 16 AWG can be used.

The FISCO FOUNDATION™ Fieldbus specification requires that cables for the Tankbus comply with the following cable parameters:

Table 3-8: FISCO Cable Parameters

Parameter ⁽¹⁾	Value
Loop resistance	15 Ω/km to 150 Ω/km
Loop inductance	0.4 mH/km to 1 mH/km
Capacitance	45 nF/km to 200 nF/km
Maximum length of each spur ⁽²⁾ cable	60 m in apparatus class IIC and IIB
Maximum cable length including trunk ⁽³⁾ and spurs	1000 m in apparatus class IIC and 1900 m in apparatus class IIB

(1) For further information see requirements of the IEC 61158-2 standard

(2) A spur is an unterminated part of the network.

(3) A trunk is the longest cable path between two devices on the fieldbus network, and is the part of the network which has terminations at both ends. In the Rosemount Tank Gauging system, a trunk is typically located between the Rosemount 2410 Tank Hub and a segment coupler or the last device in a daisy-chain configuration.

(4) See IEC 61158-2

3.4.4 Hazardous areas

When the Rosemount Rosemount 5900S level gauge is installed in hazardous areas, local regulations and specifications in applicable certificates must be observed.

3.4.5 Power requirements

The Rosemount 5900S is powered over the intrinsically safe Tankbus by the Rosemount 2410 Tank Hub. The 2410 feeds the intrinsically safe fieldbus segment by acting as a FISCO power supply on the Tankbus.

When installed in a FOUNDATION Fieldbus system without a Rosemount 2410 Tank Hub, the Rosemount 5900S is powered by the FF segment.

3.4.6 Power budget

The Rosemount 5900S power consumption is 50 mA for standard devices, and 100 mA for the Rosemount 5900S 2-in-1 versions. This has to be considered when connecting field devices to the Tankbus. See section “Power Budget” in the Rosemount 2410 Tank Hub [Reference Manual](#) for more information.

3.4.7 Tankbus

The Rosemount Tank Gauging system is easy to install and wire. Devices can be “daisy-chained” thus reducing the number of external junction boxes.

In a Rosemount Tank Gauging system devices communicate with a Rosemount 2410 Tank Hub via the intrinsically safe Tankbus. The Tankbus complies with the FISCO⁽⁵⁾ FOUNDATION Fieldbus standard. The Rosemount 2410 acts as power supply to the field devices on the Tankbus. A FISCO system enables more field devices to be connected to the segment compared to conventional IS systems based on the entity concept.

Termination

A terminator is needed at each end of a FOUNDATION™ Fieldbus network. Generally, one terminator is placed in the fieldbus power supply, and the other one in the last device in the fieldbus network.

Note

Ensure that there are **two** terminators on the fieldbus.

In a Rosemount Tank Gauging system the Rosemount 2410 Tank Hub acts as power supply. Since the tank hub normally is the first device in the fieldbus segment, the built-in termination is enabled at factory.

Other devices such as the standard version of the Rosemount 5900S Radar Level Gauge, the Rosemount 2230 Graphical Field Display, and the Rosemount 2240S Multi-input Temperature Transmitter also have built-in terminators which can easily be enabled by inserting a jumper in the terminal block when necessary.

(5) FISCO=Fieldbus Intrinsically Safe Concept

Segment design

When designing a FISCO fieldbus segment a few requirements need to be considered. Cabling has to comply with FISCO requirements as described in [Cable selection for the Tankbus](#).

You will also have to ensure that the total operating current of the connected field devices is within the output capability of the Rosemount 2410 Tank Hub. The 2410 is able to deliver 250⁽⁶⁾ mA. Consequently, the number of field devices has to be considered so that the total current consumption is less than 250 mA, see [Power budget](#).

Another requirement is to ensure that all field devices have at least 9 V input voltage at their terminals. Therefore you will have to take into account the voltage drop in the fieldbus cables.

Distances are normally quite short between the Rosemount 2410 Tank Hub and field devices on the tank. In many cases you can use existing cables as long as the FISCO requirements are fulfilled (see [Cable selection for the Tankbus](#)).

See chapter “The Tankbus” in the Rosemount 2410 Tank Hub [Reference Manual](#) for more information on segment design of a Rosemount Tank Gauging system.

3.4.8 Typical installation

The example below ([Figure 3-20](#)) illustrates a system with daisy-chained field devices on a single tank. Terminators are installed at both ends of the fieldbus segment as required in a FOUNDATION Fieldbus system. In this case terminators are enabled in the Rosemount 2410 Tank Hub and a field device at the end of the network segment.

In addition to the field instruments on the Tankbus, [Figure 3-20](#) illustrates how an instrument such as a pressure transmitter can be connected to the intrinsically safe 4 -20 mA analog input of the 2410 Tank Hub.

Maximum number of HART Slave Devices:

Passive current loop: 5

Active current loop: 3

(6) In Smart Wireless Systems the 2410 can deliver 200 mA on the Tankbus

Figure 3-20: Example of a Tankbus Connection for a Single Tank

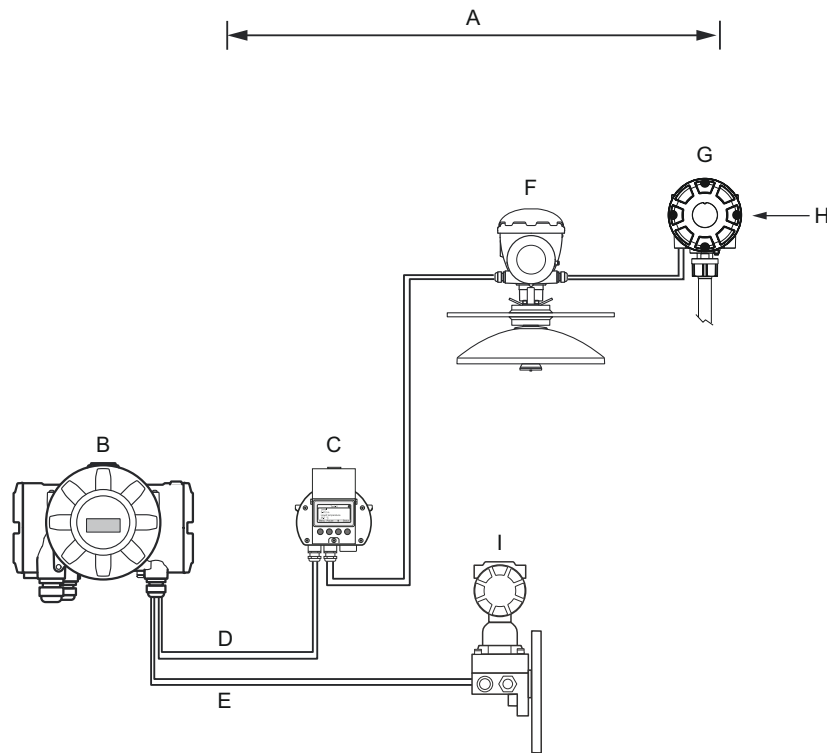

- A. Tankbus length up to 1000 meter depending on number of devices and cable type
- B. Rosemount 2410 Tank Hub with intrinsically safe power supply, integrated power conditioner, and built-in terminator
- C. Rosemount 2230 Display
- D. Tankbus
- E. IS Analog Input (Secondary bus)
- F. Rosemount 5900S Radar Level Gauge
- G. Rosemount 2240S Multi-input Temperature Transmitter
- H. Built-in terminator enabled on the last device
- I. Rosemount 3051S Pressure Transmitter

The maximum distance between the tank hub and the field devices on the tank depends on the number of devices connected to the Tankbus and the quality of cables.

See chapter “Electrical Installation” in the Rosemount 2410 Tank Hub [Reference Manual](#) for more information about cable selection, power budget, the Tankbus, and more examples on how to install systems that include the Rosemount 2410 Tank Hub.

3.4.9 Rosemount 5900S in a FOUNDATION™ Fieldbus system

The Rosemount 5900S Radar Level Gauge supports the FOUNDATION Fieldbus (FF) technology and lets you integrate it into an existing FF network. As long as the power supply meets certain requirements (see [Figure 3-21](#) and [Figure 3-22](#)) the Rosemount 5900S ⁽⁷⁾ will be able to operate as any other FF device.

Figure 3-21: Example of an I.S. FOUNDATION Fieldbus System

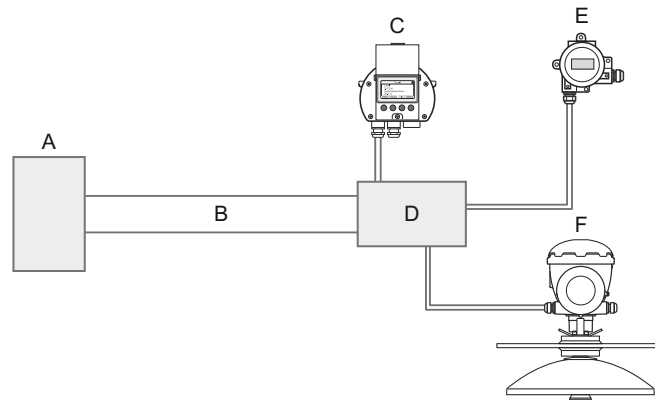

- A. I.S. Power Supply
- B. Trunk
- C. Rosemount 2230 Display
- D. Segment Coupler
- E. Rosemount 644 Temperature Transmitter
- F. Rosemount 5900S Radar Level Gauge

Ensure that the power supply is able to provide the total current needed for all the connected devices. See [Power requirements](#) and [Power budget](#) for further information.

Ensure that:

- the Rosemount 5900S and other devices connected to the FOUNDATION Fieldbus (FF) system are compliant with the FISCO or Entity parameters of the power supply.
- the short circuit protection of the Segment Coupler⁽⁸⁾ matches the current consumption of the connected devices.

⁽⁷⁾ See [Product Certifications](#) for Rosemount 5900S approval information

⁽⁸⁾ See the [Rosemount 2410 Reference Manual \(Document No. 300530EN\)](#) for more information on the Segment Coupler.

Figure 3-22: Example of a Non-I.S. FOUNDATION Fieldbus System

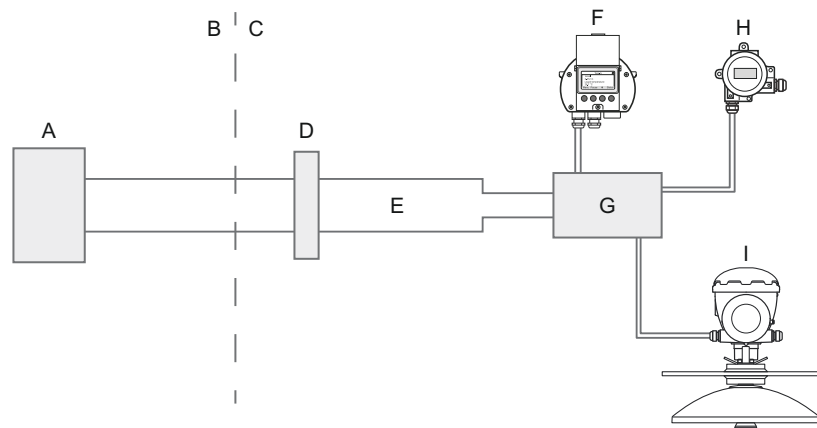

- A. Non-I.S. Power Supply
- B. SAFE AREA
- C. HAZARDOUS AREA
- D. Barrier
- E. IS Trunk
- F. Rosemount 2230 Display
- G. Segment Coupler
- H. Rosemount 644 Temperature Transmitter
- I. Rosemount 5900S Radar Level Gauge

3.4.10 Wiring

To connect the Rosemount 5900S level gauge:

Procedure

1. ⚠ Ensure that the power supply is switched off.
2. Remove the cover on the terminal compartment.
3. Run the wires through the appropriate cable gland/conduits. Install cables with a drip loop in such a way that the lower part of the loop is under the cable/conduit entry.
4. Connect wires as described in [Terminal blocks](#).
5. Ensure that the positive lead is connected to the terminal marked FB+ and the negative lead to the terminal marked FB-.
6. Use metal plugs to seal unused ports.
7. ⚠ The cover on the terminal compartment should be tightened to mechanical stop (metal to metal). Make sure the cover is fully engaged to meet explosion-proof requirements and to prevent water from entering the terminal compartment.
8. Tighten the cable gland/conduit. Note that adapters are required for M20 glands.

Note

Ensure that O-rings and seats are in good condition prior to mounting the cover in order to maintain the specified level of ingress protection. The same requirements

apply for cable inlets and outlets (or plugs). Cables must be properly attached to the cable glands.

Figure 3-23: Terminal Compartment

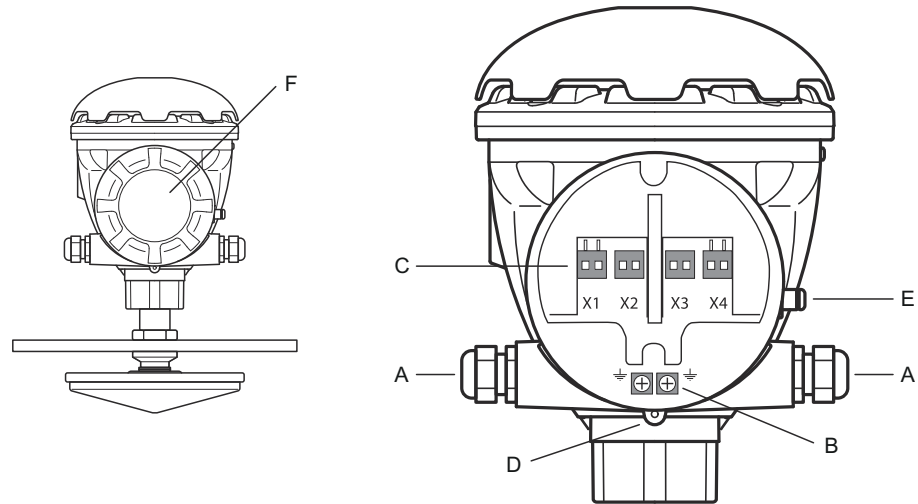

- A. Cable glands
- B. Internal Ground screws
- C. Terminals for signal and power supply
- D. Locking screw (Unscrew to lock)
- E. External Ground screw
- F. Cover

Conductor recommendations

Ensure that you use cables suitable for the terminal block of the Rosemount 5900S. The terminal block is designed for cables that meet the specifications as illustrated below.

Figure 3-24: Conductor and Insulation Requirements

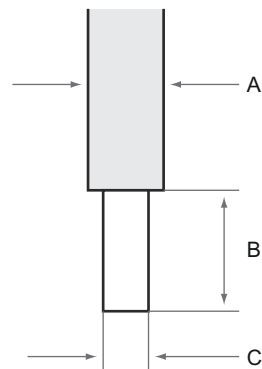

- A. Conductor insulation. Maximum diameter \varnothing : 2.9 mm.
- B. Stripping length: 8 to 9 mm.
- C. Conductor cross-sectional area, see [Table 3-9](#).

Table 3-9: Conductor Cross-sectional Area

Conductor connection	Cross-section	
	Minimum	Maximum
Solid	0.2 mm ² / AWG 24	1.5 mm ² /AWG16
Flexible	0.2 mm ² / AWG 24	1.5 mm ² /AWG16
With wire end ferrule	0.25 mm ² / AWG 24	1.5 mm ² /AWG16
With plastic collar ferrule	0.25 mm ² / AWG 24	0.75 mm ² /AWG19

In case conductor insulation diameter exceeds 2.9 mm it may not be possible to insert cable properly into the terminal block. In such a case the stripping length may have to be increased. Adjust stripping length such that no bare conductor appears outside the terminal when conductor is attached to the terminal block.

A solid conductor, or a flexible conductor with end ferrule, can easily be pushed into the terminal block without using any tools. In case a flexible (stranded) conductor is used, you will have to push the release button in order to insert the conductor.

Figure 3-25: Push the Conductor Into the Terminal Block

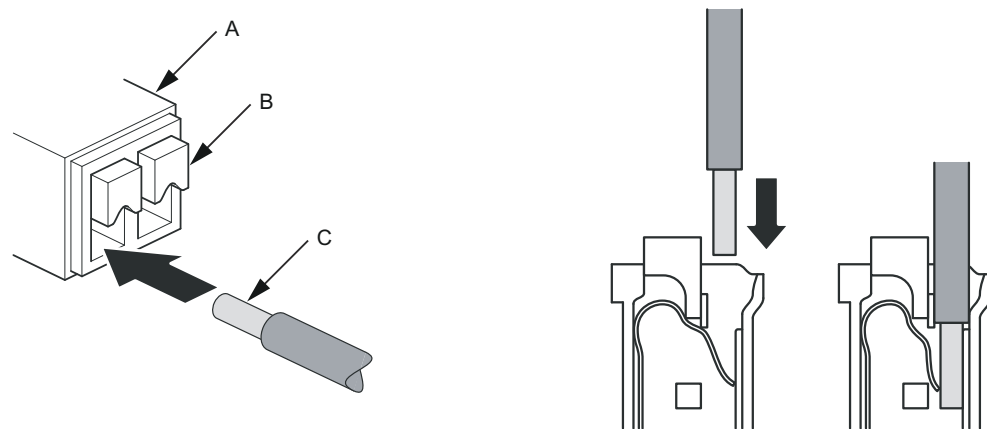

- A. Terminal block
- B. Release buttons
- C. Conductor

To disconnect, push the release button and remove the conductor.

Figure 3-26: Push the Button to Release the Conductor from the Terminal Block

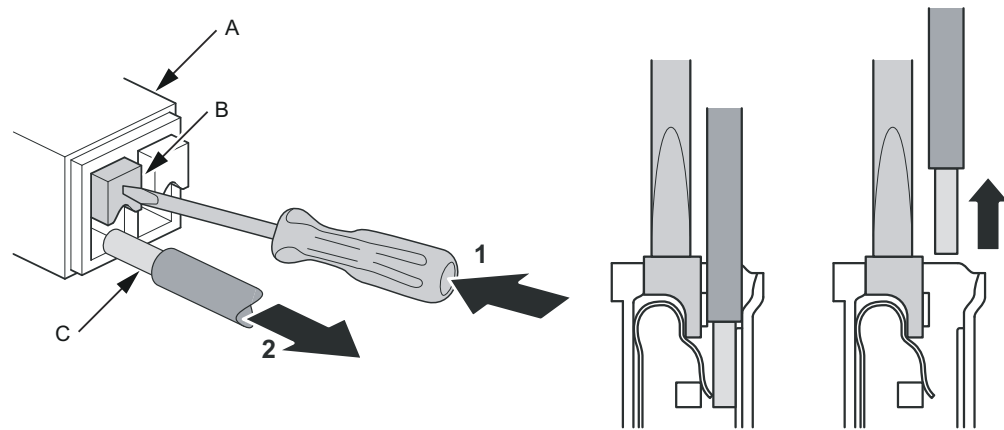

- A. Terminal block
- B. Release buttons
- C. Conductor

3.4.11 Terminal blocks

Figure 3-27: Rosemount 5900S Terminal Compartment

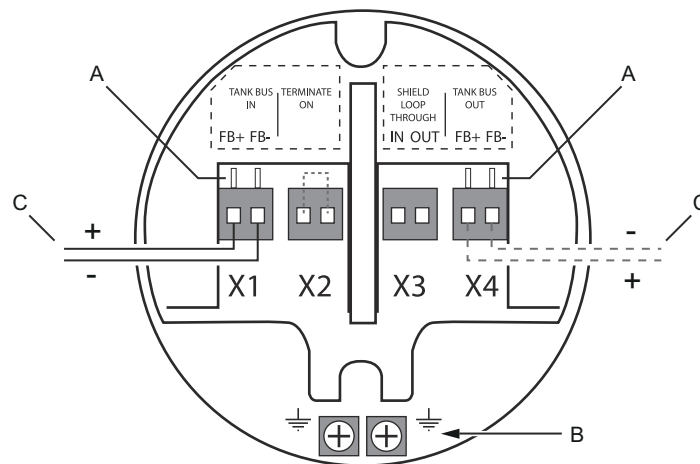

- A. Test terminals
- B. Ground terminals, internal
- C. Field bus

Table 3-10: Terminal Block Connections for the Rosemount 5900S

Connection	Description
X1: Tankbus in	Intrinsically safe Tankbus input, power and communication (spur in FOUNDATION Fieldbus system)
X2: Terminate on	The integrated line terminator is connected over the Tankbus when a jumper is placed in the terminal block
X3: Shield loop through	Cable shield daisy-chain connector (not grounded)
X4: Tankbus out	Tankbus output connected to X1 for optional daisy-chain connection to other devices
Test terminals	Test terminals for temporary connection of a Field Communicator

The X1 terminal is connected to the intrinsically safe Tankbus.

A jumper on the X2 terminal enables the built-in termination. The termination should be used if the Rosemount 5900S gauge is installed at the end of a Tankbus network. See [Tankbus](#) for more information on how to terminate the Tankbus.

The X3 terminal is used for connecting the cable shield in order to enable a continuous shield throughout the Tankbus network.

The X4 terminal can be used for “daisy-chain” connection to other devices such as the Rosemount 2240S Multi-input Temperature Transmitter, or the Rosemount 2230 Graphical Field Display. See also [Figure 3-30](#).

Terminal block Two-in-One version

The Rosemount 5900S Two-in-One version can be connected to a single Tankbus or two separate Tankbuses.

Figure 3-28: Terminal Compartment 2-in-1 Version

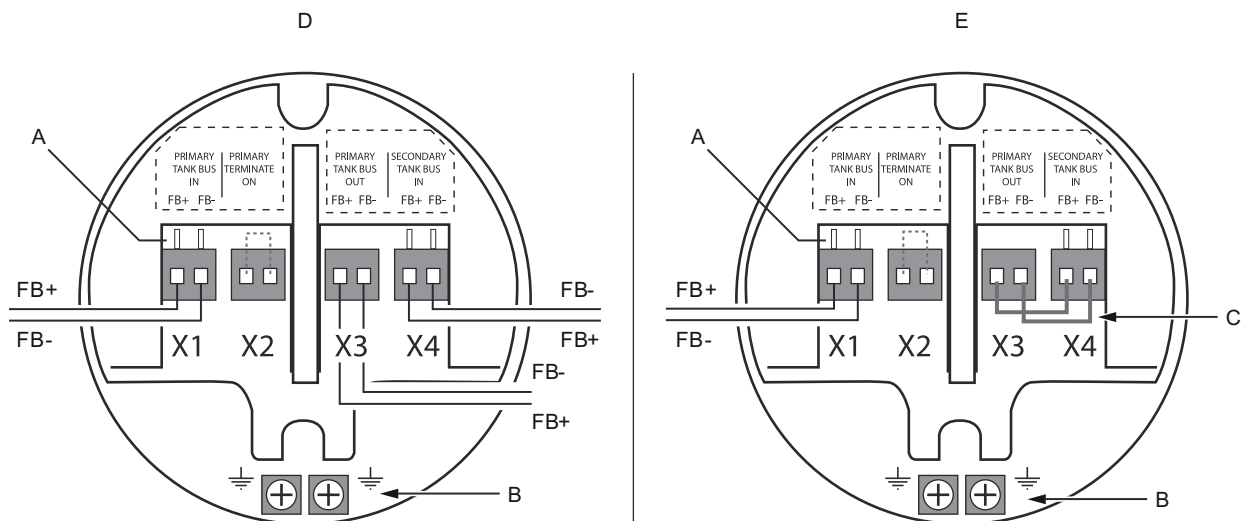

- A. Test terminals
- B. Ground terminals, internal
- C. Jumpers between X3 and X4
- D. Two tankbuses
- E. Single tankbus
- FB. Field Bus

When using two separate tankbuses, connect X1 to Tankbus 1 and X4 to Tankbus 2. Connect to X1 when using a single tankbus, and jumpers between X3 and X4.

Table 3-11: Terminal Block Connections for the Rosemount 5900S with Two Tankbuses

Connection	Two-in-One / Two tankbuses
X1: Primary Tankbus in	Intrinsically safe Tankbus input for level gauge 1, power and communication
X2: Primary Terminate on	Termination for primary tankbus. The integrated line terminator is connected over the Tankbus when a jumper is placed in the terminal block.
X3: Primary Tankbus out	Primary Tankbus output connected to X1 for optional daisy-chain connection to other devices
X4: Secondary Tankbus in	Intrinsically safe Tankbus input for level gauge 2, power and communication
Test terminals	Test terminals for temporary connection of a field communicator

Table 3-12: Terminal Block Connections for the Rosemount 5900S with Single Tankbus

Connection	Two-in-One / Single tankbus
X1: Primary Tankbus in	Intrinsically safe Tankbus input, power and communication
X2: Primary Termination	Termination for primary tankbus. The integrated line terminator is connected over the Tankbus when a jumper is placed in the terminal block.
X3: Primary Tankbus out	Jumpers between X3 and X4
X4: Secondary Tankbus in	
Test terminals	Test terminals for temporary connection of a field communicator

Gauge terminal block SIL safety system

The Rosemount 5900S has a SIL3 alarm output which is connected to the Rosemount 2410 Tank Hub.

Figure 3-29: Terminal Compartment

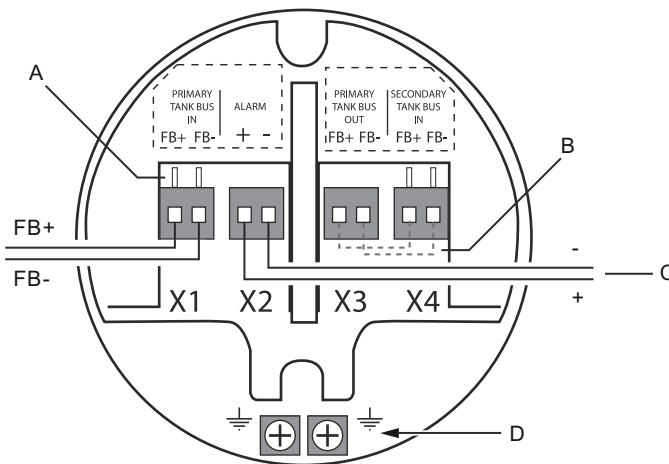

- A. Test terminals
- B. 2-in-1: optional jumpers between X3 and X4 for connection to second level gauge
- C. SIL Alarm
- D. Ground terminals, internal
- FB. Field Bus

For the 2-in-1 SIL version of the Rosemount 5900S, optional jumpers are placed between terminals X3 and X4 for connection to the second radar level gauge.

Table 3-13: Terminal Block Connections for the Rosemount 5900S with SIL Option

Connection	SIL Safety System
X1: Primary Tankbus in	Intrinsically safe Tankbus input, power and communication
X2: Alarm	SIL3 alarm output (connect to Exi terminal block on Rosemount 2410 Tank Hub)
X3: Primary Tankbus out	Optional jumpers between X3 and X4 for connection to second level gauge of the Rosemount 5900S / 2-in-1 version
X4: Secondary Tankbus in	
Test terminals	Test terminals for temporary connection of a field communicator

See the Rosemount 5900 Radar Level Gauge and 2410 Tank hub [Safety Manual](#) for Use in Safety Instrumented Systems for more information on how to setup a Rosemount Tank Gauging SIL3 safety system.

3.4.12 Wiring diagrams

The standard version of the Rosemount 5900S has a single intrinsically safe fieldbus input. You may activate a built-in fieldbus termination by short-circuiting the X2 connector.

An intrinsically safe output on connector X4 can be used for “daisy-chain” connection to other devices in a Rosemount Tank Gauging system.

Connector X3 is used for a fieldbus input/output cable shield connection (separated from chassis ground).

[Figure 3-30](#) illustrates a typical wiring diagram with a Rosemount 5900S level gauge connected to a Rosemount 2240S temperature transmitter. In this example the termination is enabled in the temperature transmitter which is the last device on the Tankbus (see [Tankbus](#)).

In case you prefer to connect the temperature transmitter to the tank hub, you may “daisy-chain” the Rosemount 5900S to the temperature transmitter, and terminate the Tankbus by a jumper in terminal X2 on the Rosemount 5900S terminal block.

Figure 3-30: Rosemount 5900S Wiring Diagram

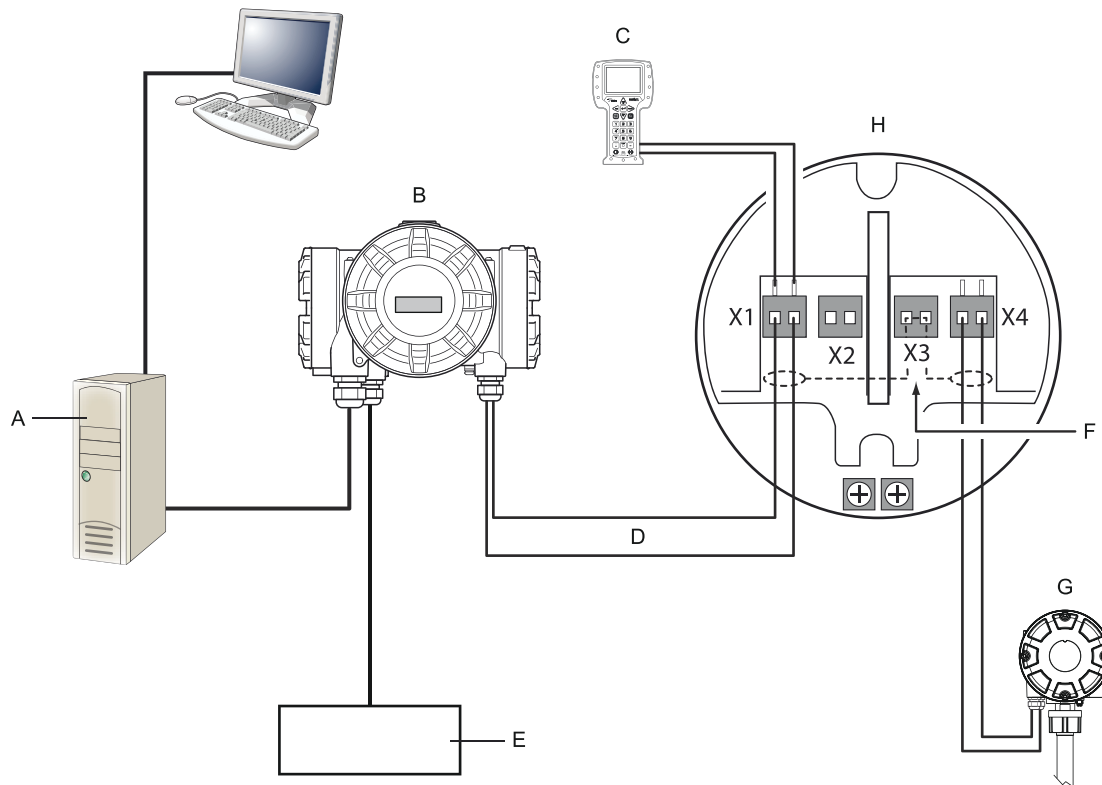

- A. Rosemount TankMaster PC
- B. Rosemount 2410 Tank Hub
- C. Field communicator
- D. Tankbus
- E. Power supply
- F. Shield
- G. Rosemount 2240S Multi-input Temperature Transmitter with built-in terminator
- H. Rosemount 5900S Radar Level Gauge

See also [Terminal blocks](#) for information on terminal block connections.

The Rosemount 5900S 2-in-1 version

The 2-in-1 version of the Rosemount 5900S has two separate level gauges in the same housing. One of the tankbuses can be terminated in the Rosemount 5900S terminal compartment.

The 2-in-1 version can be connected to two separate tankbuses as illustrated in [Figure 3-31](#) and [Figure 3-33](#), or to a single tankbus as illustrated in [Figure 3-32](#).

Terminal X1 is an intrinsically safe tankbus input for level gauge 1, and terminal X4 connects to the second level gauge.

[Figure 3-31](#) illustrates a wiring diagram with a 2-in-1 version of the Rosemount 5900S Radar Level Gauge which is “daisy-chained” to a Rosemount 2240S Multi-input

Temperature Transmitter. Note that the Primary Tankbus is terminated in the Rosemount 5900S terminal block (X2).

Figure 3-31: Rosemount 5900S Wiring Diagram for 2-in-1 Version with two Tankbuses

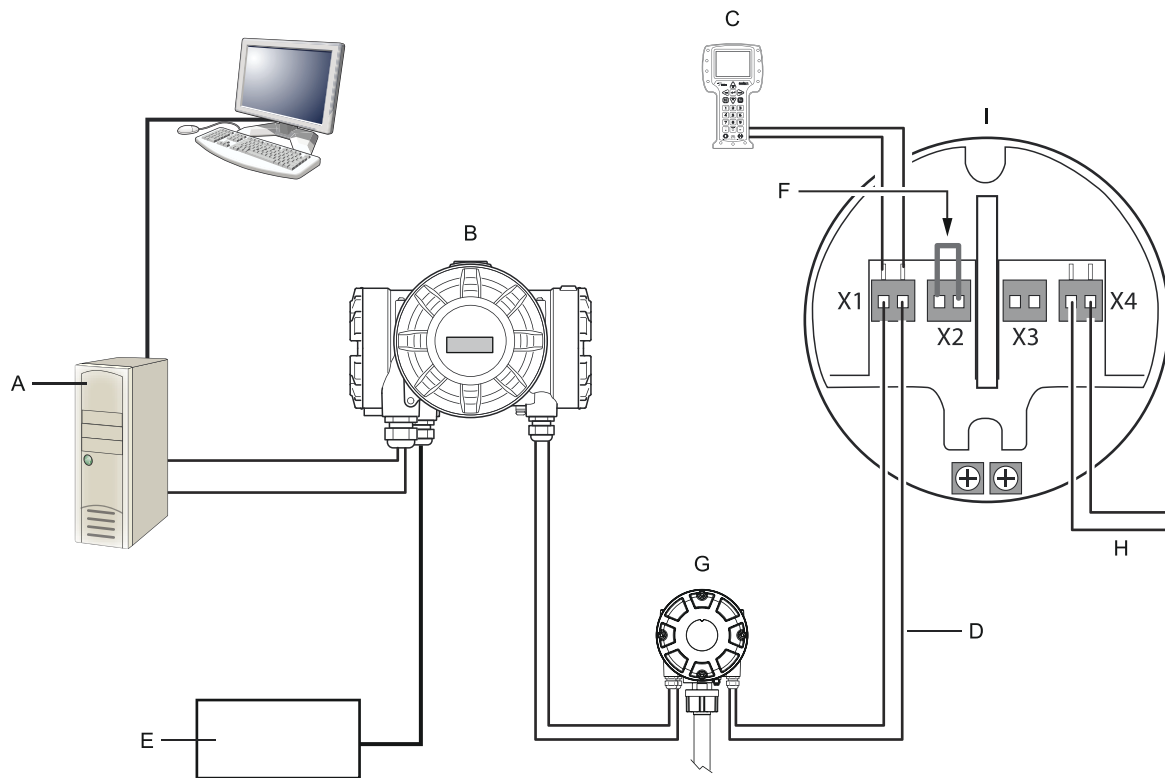

- A. Rosemount TankMaster PC
- B. Rosemount 2410 Tank Hub
- C. Field Communicator
- D. Primary Tankbus in (gauge 1)
- E. Power supply
- F. Termination
- G. Rosemount 2240S Multi-input Temperature Transmitter
- H. Secondary Tankbus (gauge 2)
- I. Rosemount 5900S Radar Level Gauge (2-in-1)

See also [Terminal blocks](#) for information on terminal block connections.

Figure 3-32 illustrates the 2-in-1 version of the Rosemount 5900S with a single intrinsically safe Tankbus. The Tankbus is connected to the first level gauge via terminal X1, and to the second level gauge via jumpers between terminals X3 (Primary Tankbus out) and X4 (Secondary Tankbus in).

Tankbus termination is enabled in the Rosemount 5900S terminal block (X2).

Figure 3-32: Rosemount 5900S Wiring Diagram for 2-in-1 Version with a Single Tankbus

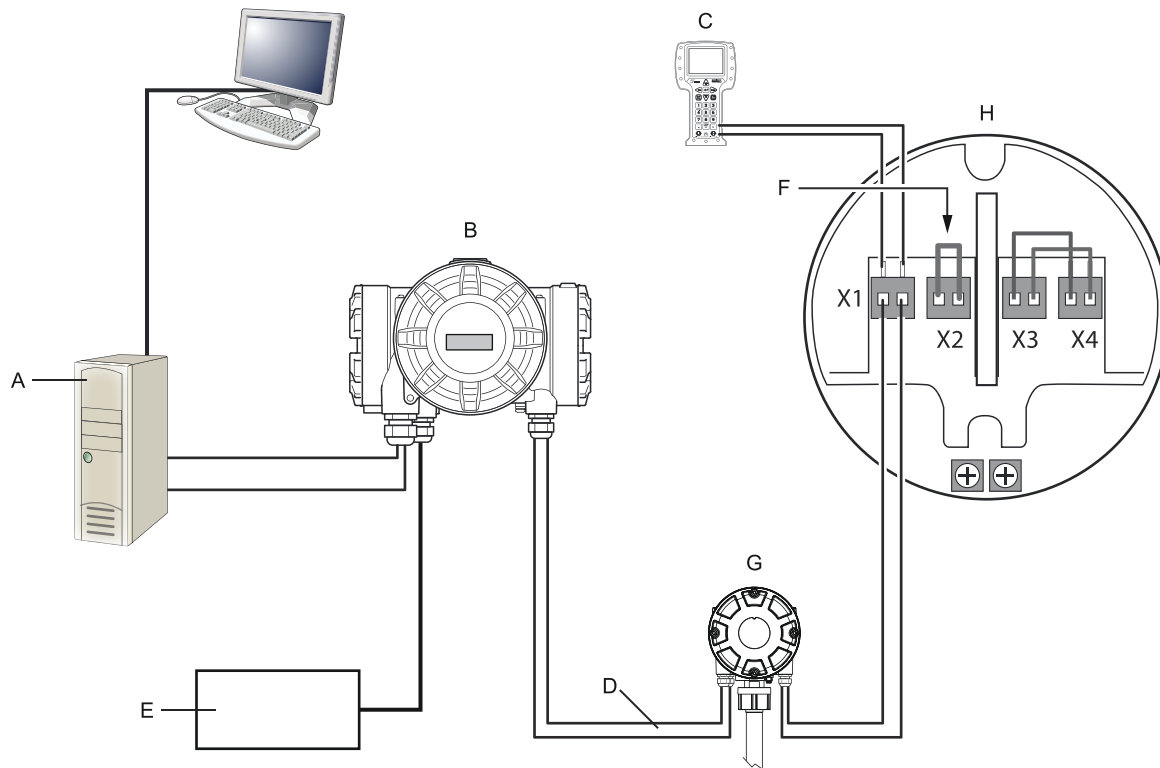

- A. Rosemount TankMaster PC
- B. Rosemount 2410 Tank Hub
- C. Field Communicator
- D. Tankbus
- E. Power supply
- F. Termination
- G. Rosemount 2240S Multi-input Temperature Transmitter
- H. Rosemount 5900S Radar Level Gauge (2-in-1)

In [Figure 3-33](#) a Rosemount 2240S temperature transmitter is wired to the second gauge of a 2-in-1 version of the Rosemount 5900S.

The Primary Tankbus is terminated in the terminal block (X2).

The Secondary Tankbus is terminated by enabling the built-in termination of the temperature transmitter.

Figure 3-33: Wiring diagram for Rosemount 5900S 2-in-1 Version with Two Tankbuses

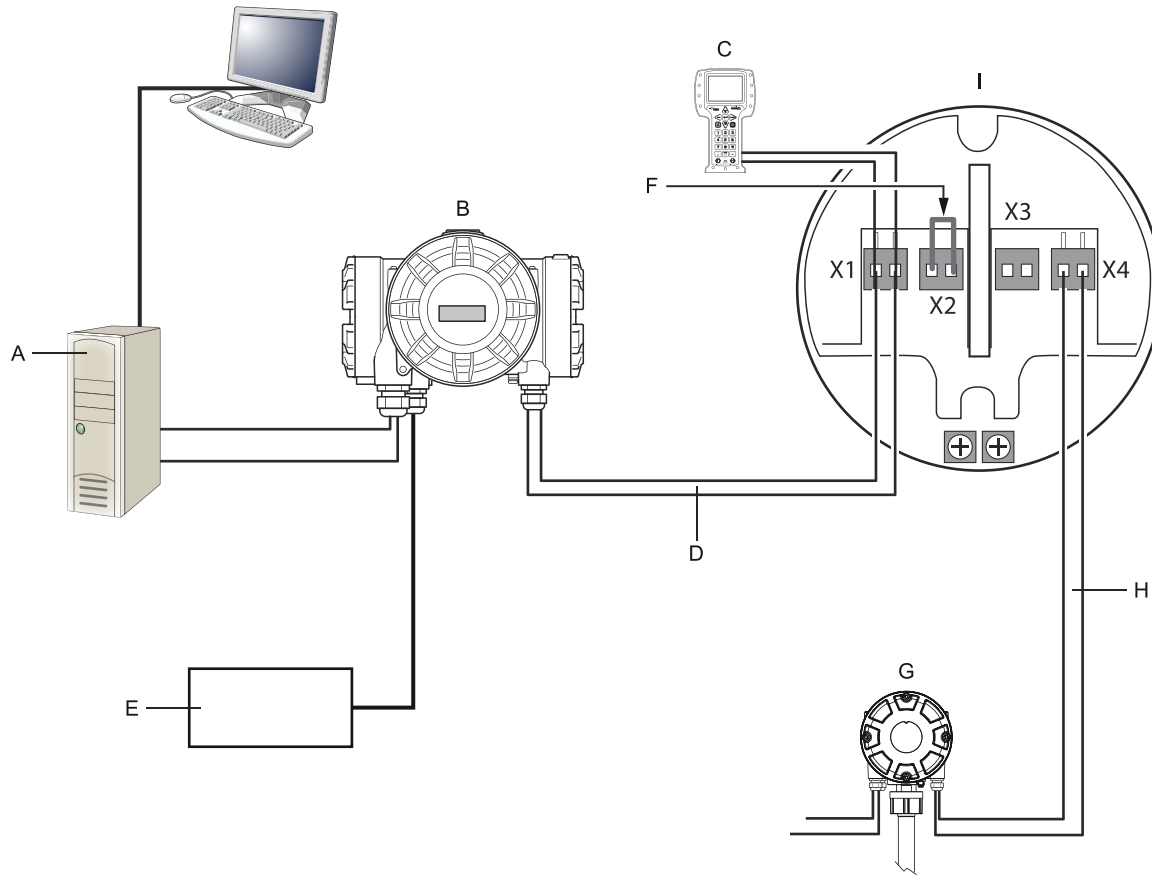

- A. TankMaster PC
- B. Rosemount 2410 Tank Hub
- C. Field Communicator
- D. Primary Tankbus in (gauge 1)
- E. Power supply
- F. Termination
- G. Rosemount 2240S Multi-input Temperature Transmitter
- H. Secondary Tankbus (gauge 2)
- I. Rosemount 5900S Radar Level Gauge (2-in-1)

4 Configuration

4.1 Safety messages

Instructions and procedures in this section may require special precautions to ensure the safety of the personnel performing the operations. Information that potentially raises safety issues is indicated by a warning symbol (⚠). Refer to the following safety messages before performing an operation preceded by this symbol.

⚠ WARNING

Failure to follow safe installation and servicing guidelines could result in death or serious injury.

- Ensure only qualified personnel perform the installation.
- Use the equipment only as specified in this manual. Failure to do so may impair the protection provided by the equipment.
- Do not perform any service other than those contained in this manual unless you are qualified.
- Substitution of components may impair Intrinsic Safety.

Explosions could result in death or serious injury.

- Verify that the operating atmosphere of the transmitter is consistent with the appropriate hazardous locations certifications.
 - Before connecting a handheld communicator in an explosive atmosphere, ensure that the instruments in the loop are installed in accordance with intrinsically safe or non-incendive field wiring practices.
 - Do not remove the gauge cover in explosive atmospheres when the circuit is alive.
-

4.2 Overview

The Rosemount™ 5900S can be installed in Rosemount Tank Gauging systems including Rosemount 2460 System Hubs and Rosemount 2410 Tank Hubs. The Rosemount 5900S also supports installation in FOUNDATION™ Fieldbus systems. See [System overview](#) for more information.

Installation of the Rosemount 5900S is a simple and straight-forward procedure. In a Rosemount Tank Gauging system with Rosemount 2410 Tank Hub and Rosemount 2460 System Hub it basically includes the following steps:

1. Preparations: make a note of Unit ID, Modbus address⁽⁹⁾, antenna type, tank geometry parameters such as tank height, tank type, strapping table.
2. Set up communication protocol and communication parameters.
3. Configuration of the Rosemount 2460 System Hub.
4. Configuration of the Rosemount 2410 Tank Hub.
5. Configuration of field devices such as the Rosemount 5900S Radar Level Gauge and the Rosemount 2240S Multiple-Input Temperature Transmitter.
6. Calibration of the Rosemount 5900S.

Installation of the Rosemount 5900S in FOUNDATION Fieldbus systems is supported by a complete set of Resource, Function, and Transducer blocks. You can easily integrate the level gauge into any existing FOUNDATION Fieldbus network by using an appropriate configuration tool such as the AMS Device Manager. See section [FOUNDATION™ Fieldbus overview](#) for more information.

The Rosemount™ TankMaster™ WinSetup program is the recommended tool for installation and configuration of a Rosemount 5900S Radar Level Gauge in systems that include a Rosemount 2410 Tank Hub. The Rosemount 5900S is preferably installed as part of the procedure when installing a tank hub:

1. Install and configure the Rosemount 2410 Tank Hub by using the device installation wizard in TankMaster WinSetup.
2. Ensure that automatic installation of field devices is enabled when finishing the tank hub installation. The Rosemount 2410 Tank Hub, Rosemount 5900S Level Gauge, and other field devices on the Tankbus will automatically appear in the WinSetup workspace.
3. Configure the Rosemount 5900S level gauge via the *Properties* window.

If a Rosemount 5900S level gauge is added to an existing system, the tank hub's database must be updated before the level gauge is configured. The tank database maps the level gauge to the tank on which it is installed.

A detailed description of how to install and configure a Rosemount 5900S and other devices by using the Rosemount TankMaster WinSetup software is provided in the Rosemount Tank Gauging [System Configuration Manual](#) .

(9) See the Rosemount Tank Gauging [System Configuration Manual](#) .

Note

If the system contains a Rosemount 2460 System Hub it should be installed and configured before other devices such as level gauges and temperature multiplexers.

See section [FOUNDATION™ Fieldbus overview](#) for more information on installing the Rosemount 5900S in FOUNDATION Fieldbus systems.

The Rosemount 5900S supports basic configuration which is sufficient in most cases. There are a number of advanced configuration options available as well, which may be used for special applications when further fine-tuning is needed.

4.2.1 Basic configuration

Basic configuration includes specifying parameters for a standard configuration. This is sufficient in most cases. A basic configuration includes the following items:

- Measurement units
- Tank geometry; tank height, tank type, tank bottom type, pipe diameter, hold off distance, calibration distance, etc.
- Process conditions; rapid level changes, turbulence, foam, solids, product dielectric range
- Volume; standard tank types, strapping table
- Tank scan; analyze the Rosemount 5900S measurement signal
- Empty tank handling; optimize measurements close to the tank bottom

See [Basic configuration](#) for more information.

4.2.2 Advanced configuration

In addition to basic configuration, the Rosemount 5900S supports advanced functions for optimizing measurement performance in certain applications. It can be fine-tuned to handle a wide range of product properties, various tank types, disturbing objects, and turbulent conditions in the tank.

Examples of advanced functions supported by the Rosemount 5900S and the Rosemount TankMaster WinSetup configuration program:

- Surface echo tracking
- Filter settings

See [Advanced configuration](#) for more information.

4.2.3 Configuration tools

Different tools are available for configuration of a Rosemount 5900S level gauge:

- Rosemount TankMaster Winsetup
- Field Communicator
- AMS Device Manager for FOUNDATION™ Fieldbus systems
- FOUNDATION Fieldbus hosts supporting DD4

The Rosemount TankMaster Winsetup is a user-friendly software package that includes basic configuration options as well as advanced configuration and service functions.

For DeltaV users, the DD can be found at www.easydeltav.com. For other hosts that use Device Descriptions (DD) and DD Methods for device configuration, the latest DD versions can be found on Foundation's website at www.fieldbus.org.

4.3 Configuration using Rosemount TankMaster

The Rosemount TankMaster WinSetup program is the recommended configuration tool for the Rosemount 5900S. Typically a Rosemount 2410 Tank Hub is connected to a Rosemount 2460 System Hub which communicates with host system via TRL2 Modbus, RS485 Modbus, Modbus TCP, or emulation protocol. A Rosemount 5900S can be installed and configured by one of the following methods:

- as part of the installation and configuration procedure of a Rosemount 2410 Tank Hub (recommended)
- by using the Rosemount TankMaster installation wizard

A Rosemount 5900S level gauge is typically installed as part of the installation procedure when installing a Rosemount 2410 Tank Hub in Rosemount TankMaster WinSetup. Then the level gauge appears in the WinSetup workspace and is configured in a separate stage via the *Properties* window.

See the Rosemount Tank Gauging [Configuration Manual](#) for more information on how to configure a Rosemount 5900S Radar Level Gauge.

4.3.1 Installation wizard

The Rosemount TankMaster WinSetup installation wizard is a tool that facilitates installation and configuration of Rosemount 5900S and other devices. This may be useful in case the Rosemount 5900S was not installed as part of the installation procedure for the Rosemount 2410.

See the Rosemount Tank Gauging [System Configuration Manual](#) for more information.

Note

In case the Rosemount 5900S level gauge was installed “offline” via a Rosemount 2410 Tank Hub, it needs to be configured separately via the *Properties* window.

To install a Rosemount 5900S by using the Rosemount TankMaster WinSetup wizard do the following:

Procedure

1. Start the TankMaster WinSetup program.
2. Select the **Devices** folder.
3. Click the right mouse button and select **Install New**.
4. Follow the instructions.

There are a number of configuration options available which are not included in the installation wizard. See [Basic configuration](#) and [Advanced configuration](#) for information on how to use various options such as Tank Scan, Empty Tank Handling, Surface Echo Tracking and Filter Settings.

4.4 Basic configuration

4.4.1 Tank geometry

The following parameters are used for tank geometry configuration of a Rosemount 5900S Radar Level Gauge:

Figure 4-1: Tank Geometry Parameters for the Rosemount 5900S

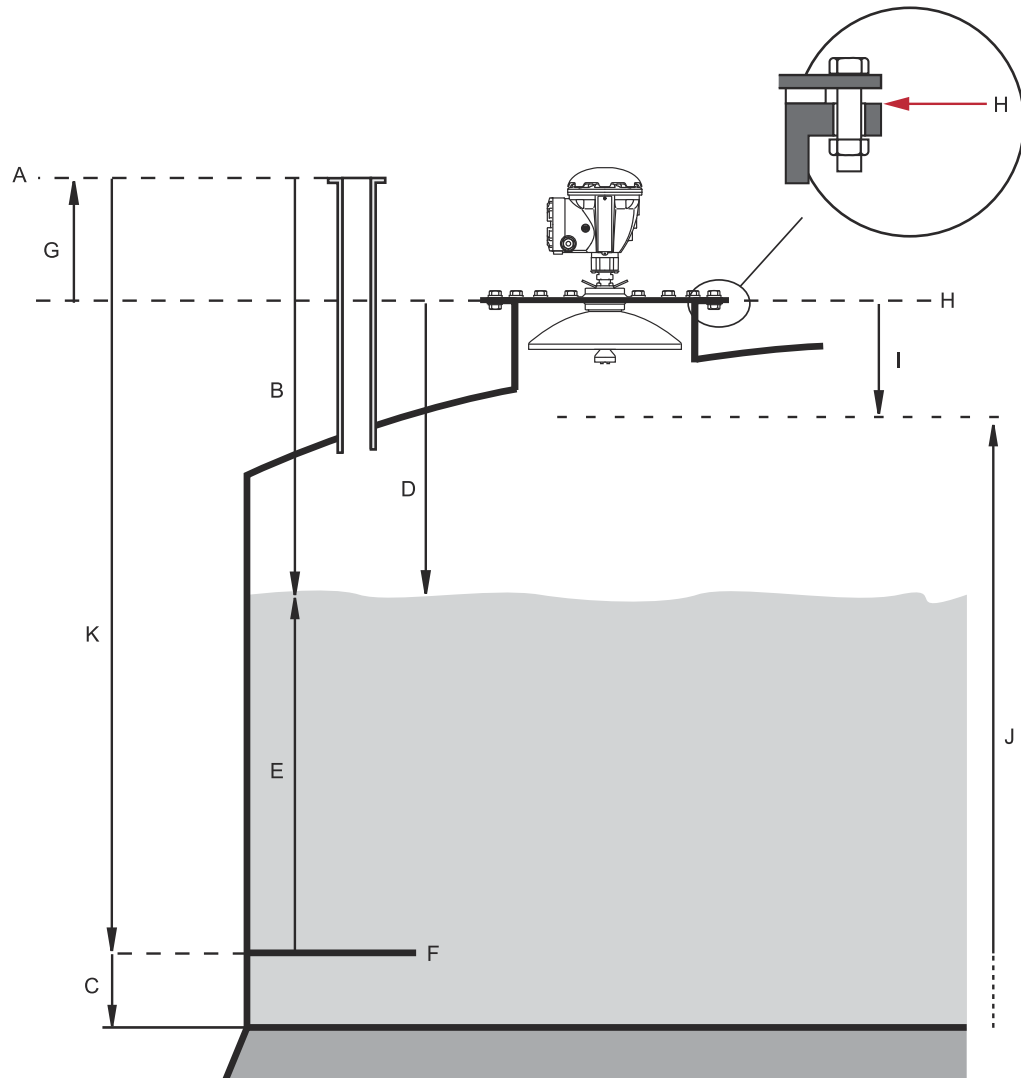

- A. Tank Reference Point
- B. Tank Ullage
- C. Minimum Level Offset (C)
- D. Ullage
- E. Level
- F. Zero Level (Dipping Datum Point)
- G. Gauge Reference Distance (G)
- H. Gauge Reference Point
- I. Hold Off Distance
- J. Measuring range
- K. Tank Reference Height (R)

Table 4-1: Definition of Tank Geometry Parameters

Parameter	Definition
Tank Height (R)	Distance from Tank Reference Point to Zero level
Gauge Reference Distance (G)	Distance from Tank Reference Point to the Gauge Reference Point
Minimum Level Offset (C)	Distance from Zero Level to tank bottom
Hold Off Distance	Defines how close to the Gauge Reference Point levels can be measured

The Rosemount 5900S with Array Antenna and hinged hatch allows you to hand dip by opening the lid and moving the gauge away from the tank opening. A hand dip plate is located inside the hatch. The plate is used as the Tank Reference Point for the tank geometry parameter Tank Height (R).

Figure 4-2: Tank Geometry for Array Antenna with Hinged Hatch

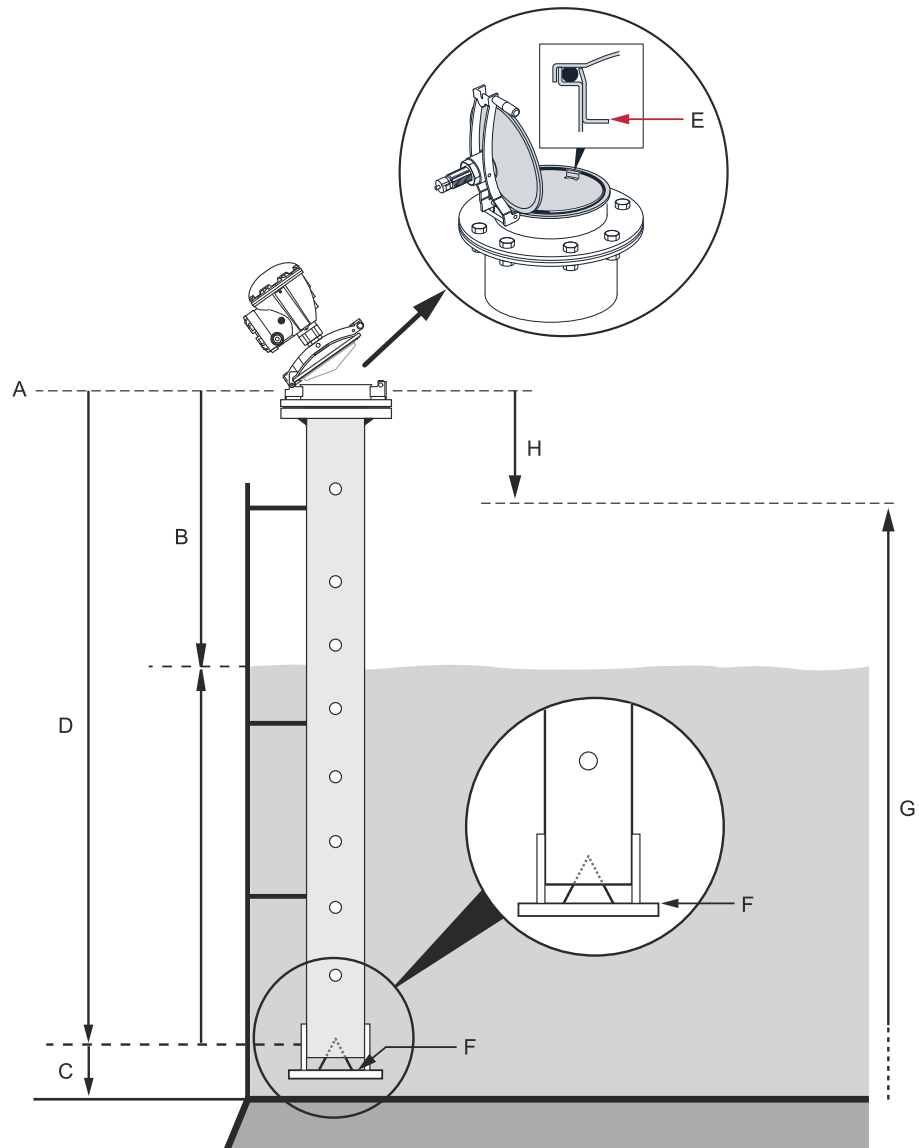

- A. Tank Reference Point
- B. Tank Ullage
- C. Minimum Level Offset (C)
- D. Tank Reference Height (R)
- E. Hand dip plate / Tank Reference Point
- F. Zero Level (Dipping Datum Point)
- G. Measuring range
- H. Hold Off Distance

Tank Reference height (R)

The Tank Reference Height (R) is the distance from the hand dipping nozzle (Tank Reference Point) to the Zero Level (Dipping Datum Plate) close to, or at the bottom of the tank. For the Array Antenna with hinged hatch the reference point is located at the hand dip plate as illustrated in Figure 4-2.

Gauge Reference distance (G)

The Gauge Reference Distance (G) is measured from the Gauge Reference Point to the Tank Reference Point, which is located at the top surface of the customer's flange or manhole cover on which the level gauge is mounted as illustrated in Figure 4-1 and Figure 4-3.

For the hinged hatch version of the Rosemount 5900S with Array Antenna, the Tank Reference Point and the Gauge Reference Point are located at the same position i.e. at the hand-dip plate on the Still Pipe Gauge Stand as illustrated in Figure 4-2.

Set $G=0$ for the Rosemount 5900S with Array Antenna hinged hatch version when using the hand dip plate as the Tank Reference Point (see Figure 4-2).

G is positive if the Tank Reference Point is located above the Gauge Reference Point. Otherwise G is negative.

Figure 4-3: Definition of Gauge Reference Distance

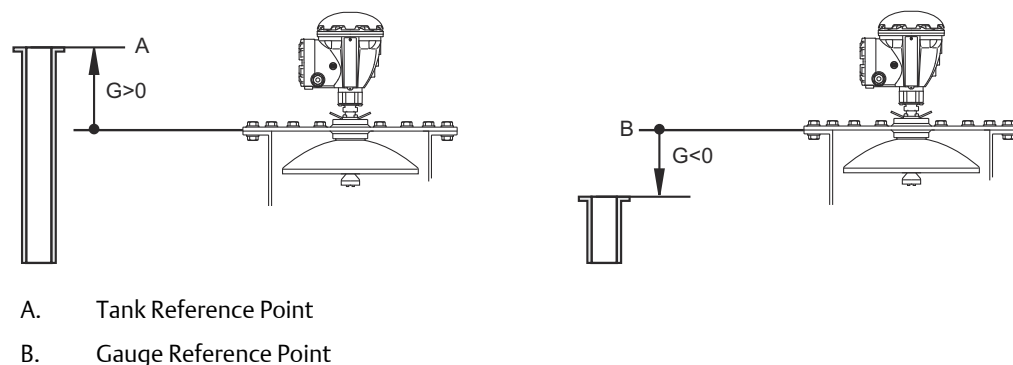

Minimum Level Offset (C)

The Minimum Level Distance (C) is defined as the distance between the Zero Level (Dipping Datum Point) and the Minimum Level of the product surface (tank bottom). By specifying a C-distance, the measuring range can be extended to the bottom of the tank.

If $C > 0$, negative level values will be displayed when the product surface is below the Zero Level. Select the **Show negative level values as zero** check box in *Rosemount TankMaster WinSetup* if you want levels below the Zero Level to be displayed as Level=0.

Measurements below the Zero Level will not be approved if the C-distance=0, i.e. the Rosemount 5900S will report an invalid level.

Hold Off distance

The Hold Off distance defines how close to the Gauge Reference Point a level value is accepted. Normally the Hold Off distance does not need to be changed. However, if there are disturbing echoes in the upper part of the tank, for example from the tank nozzle, you can increase the Hold Off distance in order to avoid measurements in the region close to the antenna.

Calibration distance

Use this variable to calibrate the Rosemount 5900S so that measured product levels match hand dipped levels. A minor adjustment may be necessary when the gauge is installed if, for example, there is a deviation between the actual tank height and the height given by tank drawings.

See [Calibration using WinSetup](#) for more information.

Pipe diameter

When a Rosemount 5900S Radar Level Gauge is installed in a still-pipe, the inner diameter of the pipe must be specified. The Pipe Diameter is used to compensate for the lower microwave propagation speed inside the pipe. An incorrect value results in a scale factor error. If locally supplied still pipes are used, make sure the inner diameter is noted before the pipe is installed.

4.4.2

Tank Scan

The *Tank Scan* window is a useful tool for analyzing the measurement signal. It allows you to view tank echoes and setup the most important parameters to enable the gauge to distinguish between the surface echo and disturbing echoes and noise.

To open the *Tank Scan* window:

Procedure

1. Start the TankMaster WinSetup program.
2. In the *TankMaster WinSetup* workspace, click the right mouse button on the icon that represents the Rosemount 5900S Radar Level Gauge.
3. From the popup menu choose the **Properties** option.
The *RLG Properties* window appears.
4. In the *RLG Properties* window, select the **Advanced Configuration** tab.
5. Click the **Tank Scan** button to open the *Tank Scan* window:

Figure 4-4: The Tank Scan Window

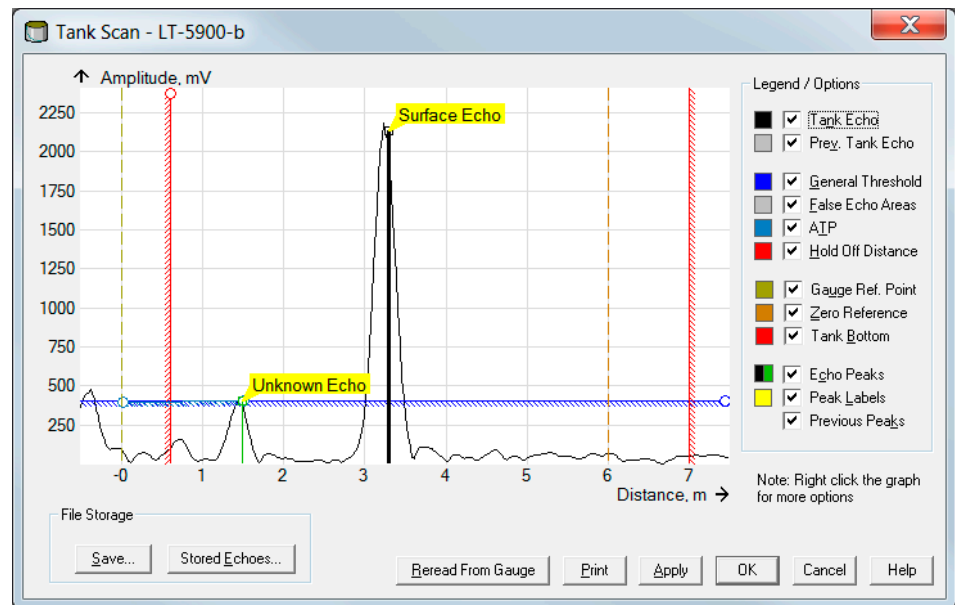

When the *Tank Scan* window is opened, the system starts reading tank data from the gauge (indicated by a progress bar in the lower right-hand corner).

Tank scan window

The *Tank Scan* window contains the Graph Area, Legend/Options area, File Storage buttons, and various action buttons.

The Tank Echo curve shows the measurement signal in graphical form. In addition to the surface echo there might be echoes from obstacles in the tank.

In the graph area you can configure the gauge to filter out echoes that originate from obstacles in the tank in order to facilitate tracking of the product surface echo.

The tank echo and echo peaks can be refreshed at any time with the **Reread From Gauge** button. The new echo curve will be shown as a black line and the previous curve as a grey line. The graph may show up to two old echo curves. An old echo peak will be marked by a small cross. This can be used to compare the existing tank signal with previous signals.

See the Rosemount Tank Gauging [System Configuration Manual](#) for more information on how to use the Tank Scan function.

4.4.3 Empty tank handling

The Empty Tank Handling function handles situations when the surface echo is close to the tank bottom. It has the ability to:

- track weak product echoes
- handle lost echoes

If the surface echo is lost this function makes the Rosemount 5900S present a zero-level measurement.

To open the *Empty Tank Handling* window:

Procedure

1. In the *TankMaster WinSetup* workspace, click the right mouse button on the icon that represents the desired Rosemount 5900S Radar Level Gauge.
2. From the popup menu choose the **Properties** option.
The *RLG Properties* window appears.
3. In the *RLG Properties* window, select the **Advanced Configuration** tab.
4. Click the **Empty Tank Handling** button:

Figure 4-5: The WinSetup Empty Tank Handling Window

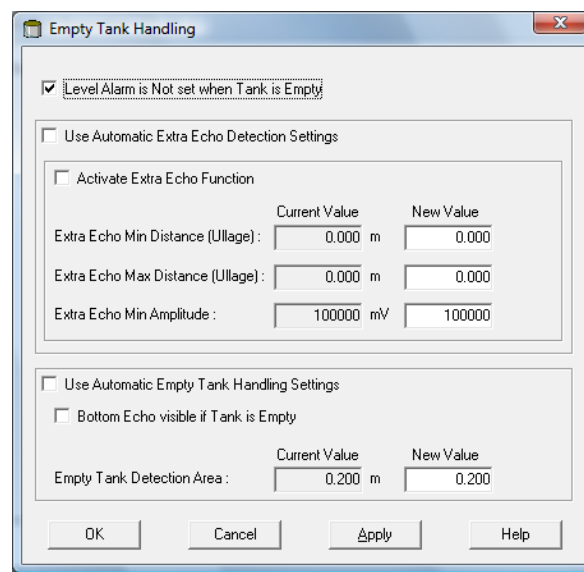

Level alarm is not set when tank is empty

In case the product surface echo is lost in the Empty Tank Detection Area close to the tank bottom, the device will enter Empty Tank state and an Invalid Level Alarm is triggered (appears in the *Diagnostics* window).

Enable this check box if you don't want this alarm to be triggered when the gauge enters empty tank state.

Activate Extra Echo function

The Extra Echo Detection function is used for tanks with a dome or conical bottom shape provided the tank bottom does not produce a strong echo when the tank is empty. This function results in more robust measurements near the tank bottom.

For tanks with a conical bottom, an echo may appear beneath the actual tank bottom when the tank is empty. If the device is not able to detect the tank bottom this function can be used to ensure that the device stays in empty tank state as long as this extra echo is present.

You can find out if such an echo exists by using the Tank Scan function when the tank is empty. Ensure that the scan extends below the tank bottom. The tank spectrum can be used to find suitable values for parameters such as the Extra Echo Min Distance, Extra Echo Max Distance and Extra Echo Min Amplitude. The tank is considered empty when an echo appears within the Min and Max Distance at an amplitude above the specified threshold.

Extra Echo Min Distance

Defines the minimum distance to the extra echo. This parameter should be greater than the Tank Height.

Extra Echo Max Distance

Defines the maximum distance to the extra echo. This parameter should be greater than the Extra Echo Min Distance.

Extra Echo Min Amplitude

Defines the minimum signal strength of the extra echo. If the signal strength exceeds this value and is found in the region between Min Distance and Max Distance, the device stays in empty tank state and presents Level=0.

Figure 4-6: Extra Echo Function

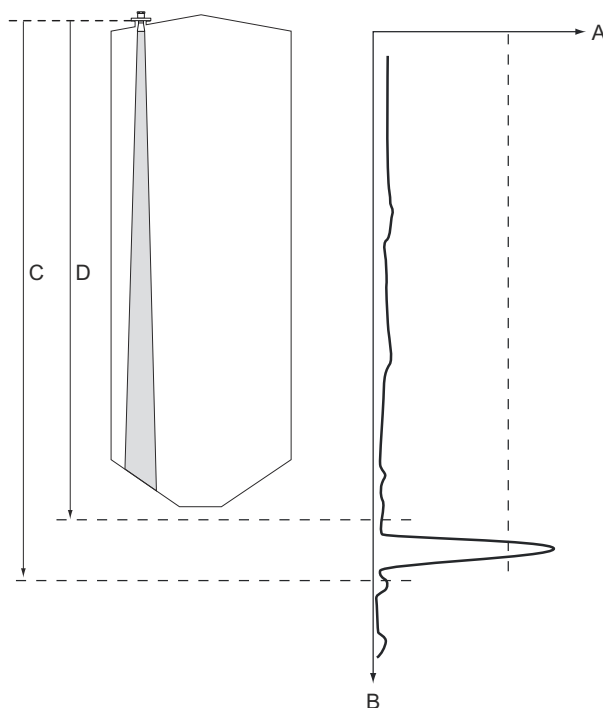

- A. Amplitude
- B. Distance
- C. Extra Echo Max. Distance
- D. Extra Echo Min. Distance

Bottom echo visible if tank is empty

By using this function the level gauge will be able to track relatively weak surface echoes close to the tank bottom by treating the bottom echo as a disturbance echo. This function may be useful for products which are relatively transparent for microwaves such as oil.

Before activating this function, you should use the WinSetup/Tank Scan function to find out if there is a clearly visible echo at the tank bottom when the tank is empty. If this is the case, the **Bottom Echo Visible If Tank Is Empty** check box in the *Empty Tank Handling* window should be marked.

If the Bottom Echo Visible... function is disabled, searching for the product surface echo is limited to a region close to the tank bottom (Empty Tank Detection Area).

If there is no strong bottom echo interfering with the surface echo, mark the **Use Automatic Empty Tank Handling Settings** check box to let the level gauge automatically control the empty tank handling function.

Figure 4-7: Bottom Echo Visible

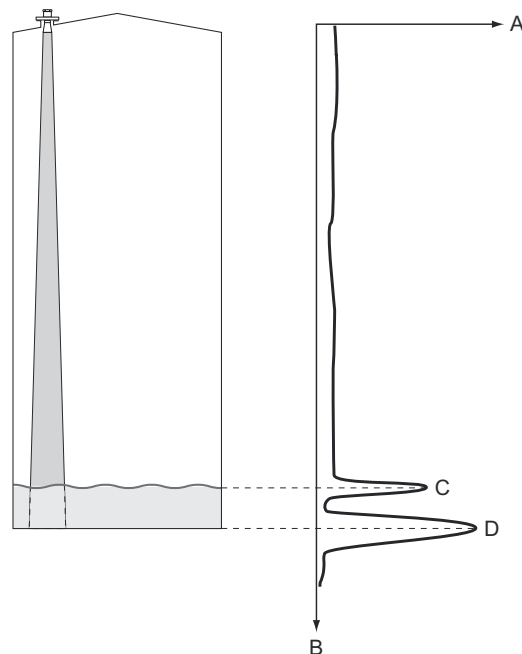

- A. Amplitude
- B. Distance
- C. Surface echo
- D. Echo at tank bottom

Empty Tank Detection Area

The Empty Tank Detection Area defines a range within a lower limit of 200 mm (8 in.) above the tank bottom. If the surface echo is lost in this region, the tank is considered empty (the device enters Empty Tank State) and the level gauge presents a zero level reading.

If the tank is empty the level gauge searches for the product surface in a region 2 x Empty Tank Detection Area. It is important that there are no disturbances in this area, since when a new echo is found it is considered to be the product surface. To ensure robust measurements in this region, disturbances may need to be filtered out.

The Empty Tank Detection Area is used in case there is no visible bottom echo. The Bottom Echo Visible if Tank is Empty function shall be disabled.

Figure 4-8: Empty Tank Detection Area

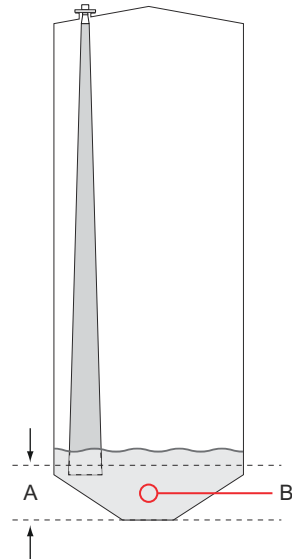

- A. Minimum 200 mm (8 in.)
- B. Empty Tank Detection Area (If the product surface is lost in this region the tank is considered empty.)

4.5 Advanced configuration

There are a number of advanced configuration options for the Rosemount 5900S gauge which may be useful in certain situations. These options are available via the Rosemount TankMaster Winsetup program and the *Rosemount 5900 RLG Properties* window.

4.5.1 Environment

Foam

You can use this parameter to optimize the gauge for conditions with low and varying surface echo amplitudes such as foam. When the foam is light and airy the actual product level is measured. For heavy and dense foam the transmitter measures the level of the upper surface of the foam.

Turbulent surface

Splash loading, agitators, mixers, or boiling products may cause a turbulent surface. Normally the waves in a tank are quite small and cause local rapid level changes. By setting the Turbulent Surface parameter the performance of the level gauge will be improved when there are small and quickly changing amplitudes and levels.

Rapid level changes

Optimize the level gauge for measurement conditions where the product level changes quickly due to filling and emptying of the tank. The Rosemount 5900S is able to track level changes of up to 1.5 inch/s (40 mm/s). The Rapid Level Changes function allows the Rosemount 5900S to track level changes of up to 8 inch/s (200 mm/s).

The Rapid Level Changes function shall not be used in normal conditions when the product surface moves slowly.

Solid products

Setting this parameter optimizes the gauge for solid products, for example concrete or grains, which are not transparent for radar signals. For instance, this parameter can be used when the application is a silo with product build-up.

Product dielectric range

The Dielectric Constant is related to the reflectivity of the product. This parameter can be used to optimize measurement performance. However, the level gauge will still be able to perform well even if the actual Dielectric Constant differs from the configured value.

4.5.2 Tank shape

The Tank Type and Tank Bottom Type parameters optimize the Rosemount 5900S for various tank geometries and for measurements close to the tank bottom.

4.5.3 Surface Echo Tracking

The Surface Echo Tracking function can be used to eliminate problems with certain types of ghost echoes below the product surface. This may, for example, occur in still-pipes as a result of multiple reflections between the pipe wall, flange and antenna. In the tank spectrum these echoes appear as amplitude peaks at various distances below the product surface.

To activate this function, ensure that there are no disturbing echoes above the product surface and select the **Always Track First Echo** check box.

To open the *Surface Echo Tracking* window:

Procedure

1. In the *TankMaster WinSetup* workspace, click the right mouse button on the desired Rosemount 5900S icon.
2. Choose the **Properties** option from the popup menu.
3. In the *RLG Properties* window, select the **Advanced Configuration** tab.
4. Click the **Surface Echo Tracking** button:

Figure 4-9: The WinSetup Surface Echo Tracking Window

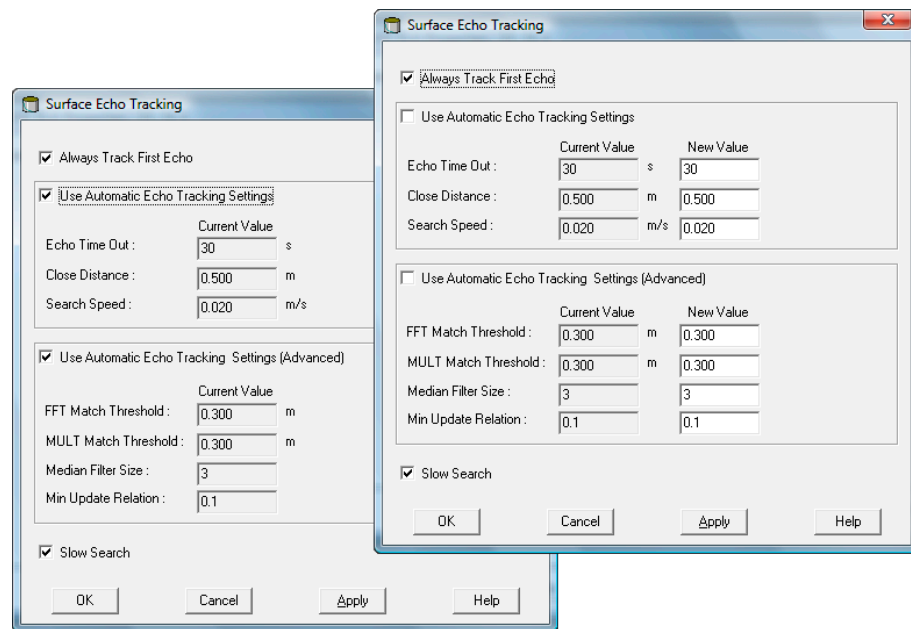

Echo Time Out

Use Echo Time Out to define the delay time until the gauge will start searching for a surface echo after it has been lost. Until this period of time has elapsed, the gauge will not start searching or trigger any alarms.

Close Distance

This parameter defines a window centered at the current surface level in which new surface echo candidates can be selected. The size of the window is \pm Close Distance. Echoes outside this window will not be considered as surface echoes. The level gauge will immediately jump to the strongest echo (highest amplitude) inside this window. If there are rapid level changes in the tank, you may need to increase the Close Distance window in order to prevent the gauge from missing any level changes. On the other hand, if the Close Distance window is too large, the gauge might select an invalid echo as the surface echo.

Slow Search

The Slow Search function controls the search behavior if the product surface echo is lost, and may typically be used for tanks with turbulent conditions. The gauge starts searching for the surface at the last known product level, and gradually increases the search region until the product surface is found. When this function is disabled, the gauge searches through the whole tank.

Search Speed

The Search Speed parameter indicates how quickly the search region (Slow Search window) is expanded when the Slow Search function is active.

4.5.4 Filter setting

To open the *Filter Setting* window:

Procedure

1. In the *TankMaster WinSetup* workspace, click the right mouse button on the desired Rosemount 5900S Radar Level Gauge icon.
2. Choose the **Properties** option from the popup menu.
3. In the *RLG Properties* window, select the **Advanced Configuration** tab.
4. Click the **Filter Setting** button:

Figure 4-10: The WinSetup Filter Setting Window

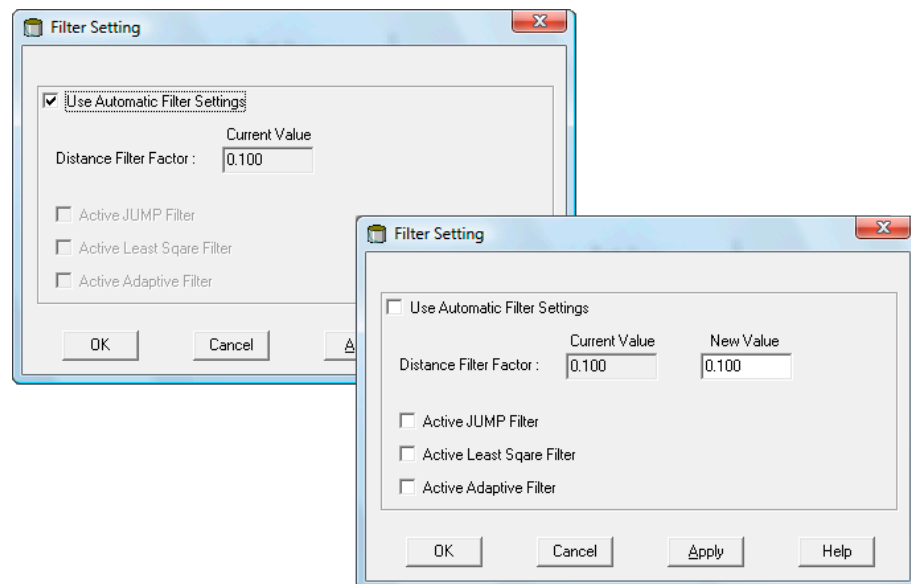

Distance Filter Factor

This parameter defines the amount of product level filtering (1 = 100%).

A low Filter Factor means that a new level value is calculated by adding a small fraction (for instance 1%) of the level change to the last known level value. It makes the level value steady but the device reacts slowly to level changes in the tank.

A high filter factor means that a larger fraction of the level change is added to the current level value. This setting makes the device react quickly to level changes but the presented level value can sometimes be somewhat jumpy.

Jump Filter

The Jump Filter is typically used for applications with turbulent surface and makes the echo tracking work smoother as the level passes, for example, an agitator. If the surface echo is lost and a new surface echo is found, the Jump Filter makes the level gauge wait some

time before it jumps to the new echo. In the mean time the gauge decides whether the new echo can be considered a valid echo.

The Jump Filter does not use the Distance Filter Factor and can be used at the same time as the Least Square or the Adaptive Filter functions.

Least Square Filter

The Least Square filter gives increased accuracy for slow filling or emptying of a tank. The level value follows the surface with high accuracy and without delay as the level changes. The Least Square filter can not be used at the same time as the Adaptive Filter.

Adaptive Filter

The Adaptive Filter automatically adapts to the movement of the surface level. It tracks product level fluctuations and continuously adjusts the filter grade accordingly. The filter can preferably be used in tanks in which fast tracking of level changes are important and turbulence occasionally cause unstable level readings.

4.6 LPG configuration

4.6.1 Preparations

Prerequisites

Before starting configuration of the Rosemount™ 5900S for LPG measurements, ensure that all mechanical installations are made according to instructions, and all external sensors such as pressure and temperature sensors are properly connected.

For Rosemount 5900S with FOUNDATION™ Fieldbus the LPG Setup is described in [LPG Setup using DeltaV / AMS Device Manager](#).

Highly pressurized vapor above the product surface affects the propagation speed of microwaves. The Rosemount 5900S level gauge is able to compensate for this, thus avoiding deviations in measured level due to the vapor.

When the gauge is installed on the empty tank, calibrate the gauge and configure for LPG measurements.

To install a Rosemount 5900S for LPG measurements perform the following major steps:

Procedure

1. Install the tank and the Rosemount 5900S level gauge in Rosemount TankMaster WinSetup as described in the Rosemount Tank Gauging [System Configuration Manual](#). Ensure that the appropriate tank and device types are selected, and the temperature and pressure sensors are properly configured. Check that the gauge communicates with the TankMaster PC.
2. Install the Rosemount 5900S gauge on the still-pipe. Measure the exact distance to the Verification Pin.
3. Configure the Rosemount 5900S according to the standard procedure for a Rosemount 5900S level gauge (see the Rosemount Tank Gauging [System Configuration Manual](#)). Rosemount TankMaster Winsetup is the recommended configuration tool.
4. Configure the vapor pressure sensor.
5. Set Correction Method to Air Correction Only.
6. Calibrate the Rosemount 5900S.
7. Configure the Verification Pin.
8. Verify position of Verification Pin.
9. Set up the Correction Method that applies to the particular type of product in the tank.

The LPG installation procedure using Rosemount TankMaster Winsetup is described in section [LPG setup using Rosemount™ TankMaster](#).

4.6.2 LPG setup using Rosemount™ TankMaster

This section describes how to configure the Rosemount 5900S for LPG measurements by using the Rosemount TankMaster configuration tool.

Prerequisites

In the following description it is assumed that the Rosemount 5900S with LPG/LNG Antenna is installed on the tank, and a basic configuration is performed as described in the Rosemount Tank Gauging [System Configuration Manual](#).

Configure the vapor pressure sensor

Prerequisites

Ensure that a Vapor Pressure source device is up and running.

Procedure

1. Verify that the tank is empty and the tank atmosphere contains air only.
2. Check that the ball valve (optional) on the gauge is open.
3. Configure a **Vapor Pressure** source device. Open the *ATD Properties* window and select the **Advanced Parameter Source Configuration** tab.

This tab lets you map tank parameters such as **Vapor Pressure** to source devices connected to the Tankbus.

Figure 4-11: Advanced Parameter Source Configuration Tab

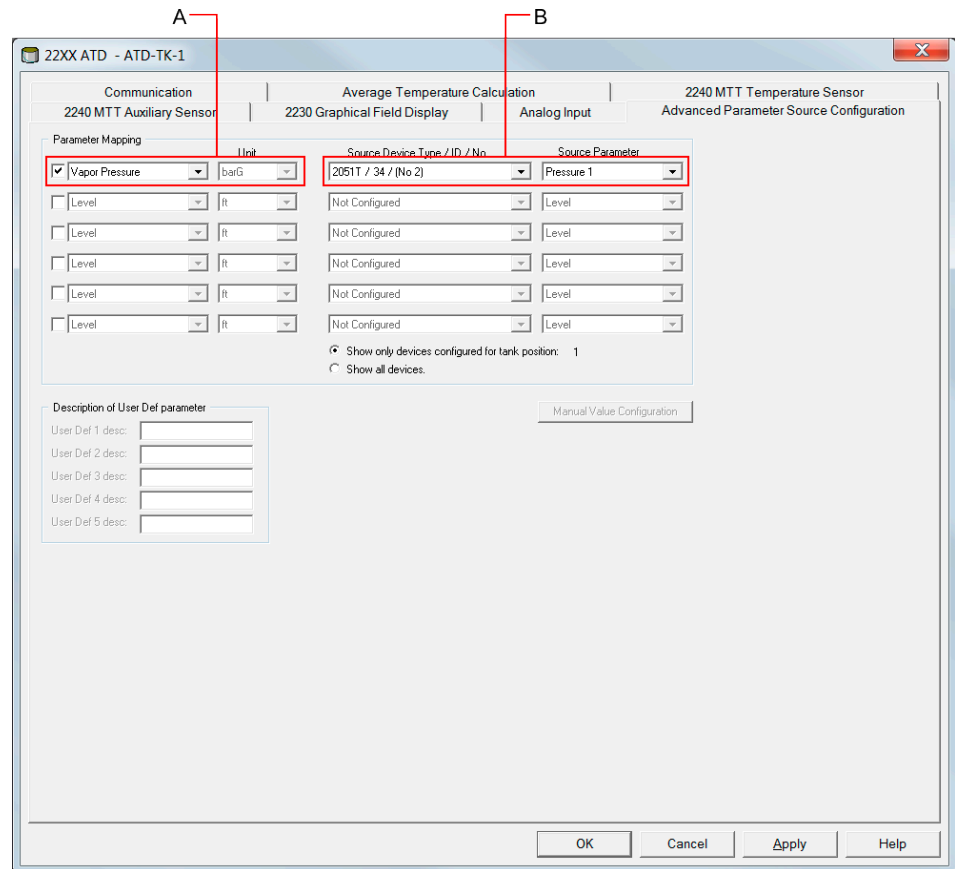

- A. Tank parameter Vapor Pressure
- B. Source device and source parameter

Note

Pressure measurement is not required for correction method One or more known gases, known mixratio (see [Choose correction method](#)).

Set the temperature parameter mapping

Rosemount™ 644 temperature transmitters have to be mapped manually in order to provide input for Vapor Temperature and Average Liquid Temperature calculations.

For Rosemount 2240S Multi-input Temperature Transmitters, temperature readings from the appropriate elements are automatically mapped to **Vapor Temperature** and **Liquid Average Temperature**.

The following description shows how to configure Rosemount 644 transmitters as temperature source devices.

Procedure

1. Choose **Temperature 1** in the *Parameter Mapping* list for the first 644 Temperature Transmitter. In case there are more than one 644 transmitters on the tank, they will have to be mapped too: for the second and third 644 transmitter, choose **Temperature 2** and **Temperature 3** in the *Parameter Mapping* list.

Note that the actual Vapor Temperature and Liquid Temperature tank parameters are not mapped. For example, the resulting Vapor Temperature will be calculated based on the output from Rosemount 644 transmitters located above the current product surface.

2. In the *Source Device Type* field, for each temperature parameter (Temperature 1, 2, 3) choose the actual Rosemount 644 transmitter to be used as source device as illustrated below.
3. In the *Source Parameter* list, choose **Temperature 1**. Note that Temperature 1 is the source parameter designation for temperature output from a Rosemount 644.

Parameter Mapping	Unit	Source Device Type / ID / No	Source Parameter
<input checked="" type="checkbox"/> Vapor Pressure	barG	2051T / 34 / (No 2)	Pressure 1
<input checked="" type="checkbox"/> Temperature 1	C	644 / 45 / (No 3)	Temperature 1
<input checked="" type="checkbox"/> Temperature 2	C	644 / 54 / (No 4)	Temperature 1
<input checked="" type="checkbox"/> Temperature 3	C	644 / 56 / (No 5)	Temperature 1
<input type="checkbox"/> Level	m	Not Configured	Level
<input type="checkbox"/> Level	m	Not Configured	Level

Show only devices configured for tank position: 1
 Show all devices

Description of User Def parameter
 User Def 1 desc:

Manual Value Configuration

Note

Ensure that temperature element positions are properly configured. This is normally done in the basic configuration of the Rosemount 5900S level gauge and is required for proper calculation of Vapor Temperature and Average Liquid Temperature.

Air Correction Only

Prior to calibrating and configuring the Verification Pin you will need to set the appropriate LPG correction method.

Procedure

1. In the Rosemount TankMaster WinSetup work space, select the **Logical View** tab.
2. Select the icon that represents the radar level gauge.
3. Click the right mouse button and select **LPG Setup** to open the *LPG Setup* window:

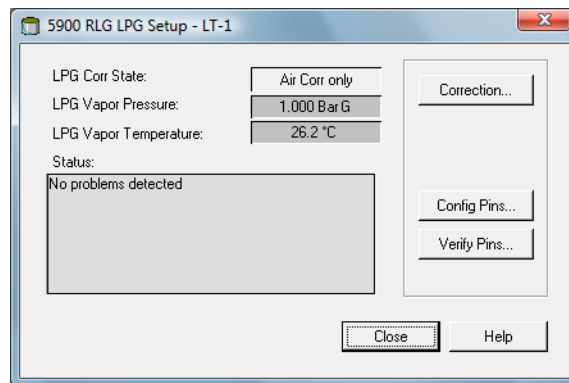

4. In the **LPG Setup** window click the **Correction** button.

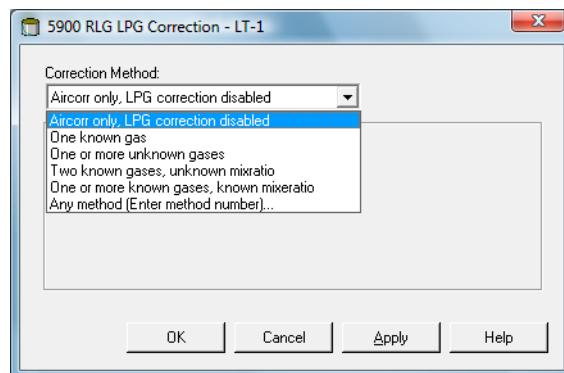

5. Choose **Air Correction Only** from the list of correction methods and click the **OK** button.

This setting is used during the Pin Verification procedure. When the LPG Setup is finished and the tank is going to be put into operation, the correction method needs to be changed to a method that applies to the particular type of product that is used.

Note

The Air Correction Only option shall only be used when the tank atmosphere contains air and no other gases.

Calibrate

Prerequisites

Ensure that there is no liquid above the calibration ring⁽¹⁰⁾ at the end of the still-pipe when calibrating the gauge. Then the calibration ring is the only object that will be detected by the gauge. The product level presented by the Rosemount 5900S will be equal to the position of the calibration ring measured from the Zero Level near the bottom of the tank.

Procedure

1. Check the distance measured by the Rosemount 5900S from the Gauge Reference Point⁽¹¹⁾ to the calibration ring.

This is referred to as the Ullage⁽¹¹⁾ value defined by: $Ullage = R - L$, where

- R is the tank height measured from the Tank Reference Point to the Zero Level. For LPG tanks the calibration ring is used as Zero Level and the Tank Reference Point is equal to the Gauge Reference Point.
- L is the product level measured from the Zero Level.

If the Ullage value is not equal to the actual distance between the **Gauge Reference Point** and the calibration ring, you will need to adjust the **Calibration Distance** parameter.

2. Right-click the device icon and select the **Properties** → **Geometry** tab.

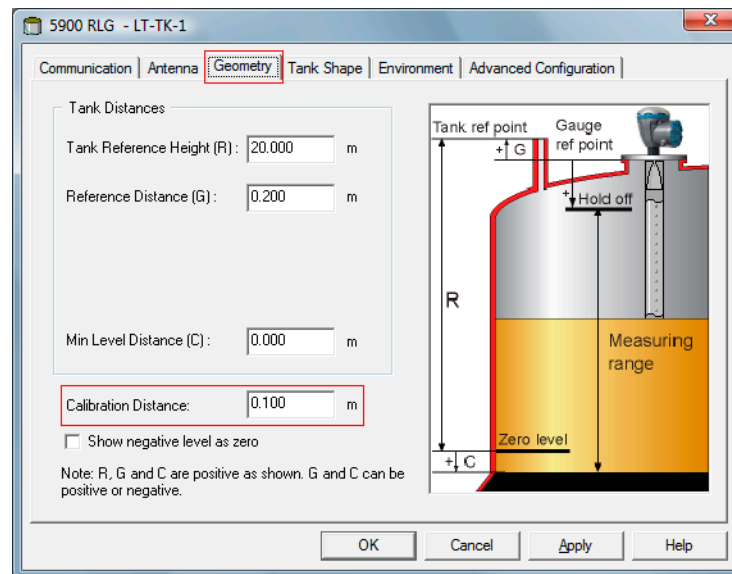

(10) See [LPG/LNG antenna requirements](#).

(11) See [Tank geometry](#).

3. Enter the desired **Calibration Distance**.

Note

It is important that the Inner Diameter of the still-pipe is properly configured. Open the **Antenna** tab in case you would like to verify the configuration. See [LPG/LNG antenna requirements](#) for more information.

Configure the verification pin

Prerequisites

Make sure that the position of the Verification Pin is accurately measured and the inner diameter of the still-pipe is available.

Note

When the product surface is close to a Verification Pin, the radar echoes from the Verification Pin and the product surface interfere. This may reduce the accuracy of the measured distance to the Verification Pin. It is recommended that verification is not performed if the distance between the Verification Pin and the product surface is less than 900 mm (see [LPG/LNG antenna requirements](#)).

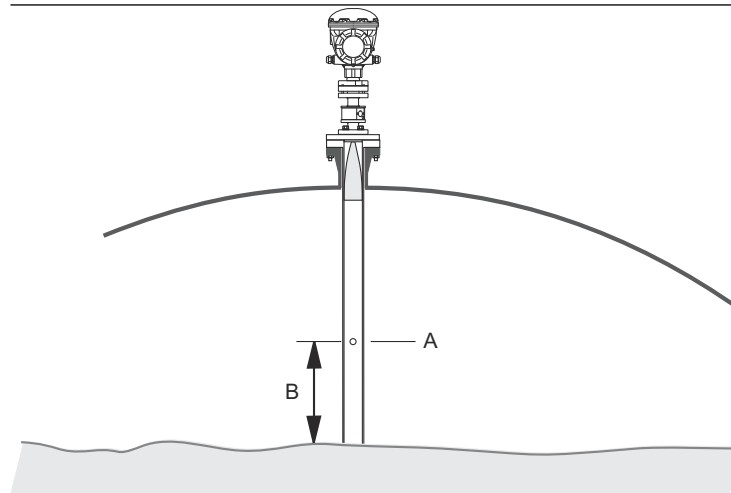

- A. Verification Pin
 - B. Minimum clearance 900 mm
-

Since hand dipping can not be performed in high pressurized tanks, Emerson Automation Solutions/ Rosemount Tank Gauging has developed a unique method to verify level gauging in such tanks. The method is based on measurements in a special radar wave propagation mode against a fixed Verification Pin in order to verify the measurement.

Procedure

1. In the Rosemount™ TankMaster WinSetup work space, select the *Logical View* tab.
2. Select the icon that represents the desired radar level gauge.

3. Click the right mouse button and select **LPG Setup** to open the *LPG Setup* window:

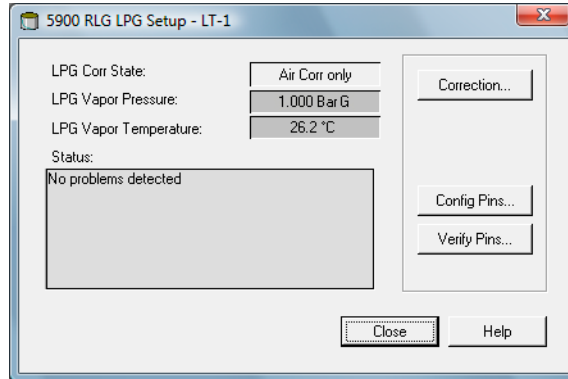

4. In the *LPG Setup* window, click the **Config Pins** button.

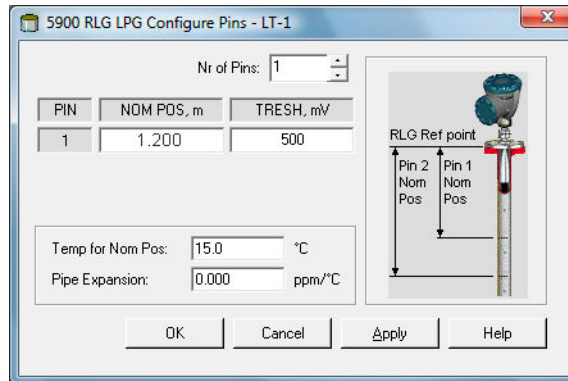

5. In the *LPG Configure Pins* window, enter the position of the Verification Pin in the **Nominal Position (NOM POS)** input field.

The position is measured from the Gauge Reference Point to the actual position of the Verification Pin.

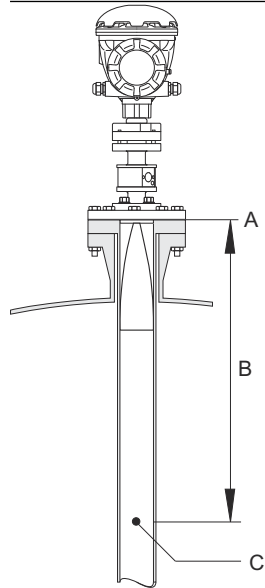

- A. Gauge Reference Point
- B. Distance from gauge reference point to Verification Pin
- C. Verification Pin

Note

The value entered in the *Nominal Pos* field refers to the mechanical distance from the Gauge Reference Point to the actual Verification Pin. This value will only act as a starting point for the verification process in which the electrical distance from the Gauge Reference Point to the Verification Pin is calculated. In most cases the electrical distance deviates from the actual mechanical distance.

6. Ensure that the Threshold value is 500 mV.

The amplitude of the echo from the Verification Pin must be above the threshold value in order to appear in the *LPGVerify* window (see [Verify the gauge measurement](#)). In case the Verification Pin does not show up, it is possible to use a smaller threshold value. Check that the product level is not above the Verification Pin.

Verify the gauge measurement

Procedure

1. In the Rosemount™ TankMaster WinSetup work space, select the *Logical View* tab.
2. Select the icon that represents the desired radar level gauge.
3. Click the right mouse button and select **LPG Setup** to open the *LPG Setup* window:

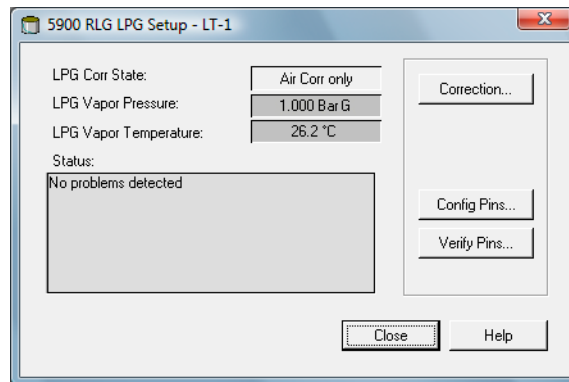

4. In the *LPG Setup* window, click the **Verify Pins** button to open the *LPG Verify Pins* window.

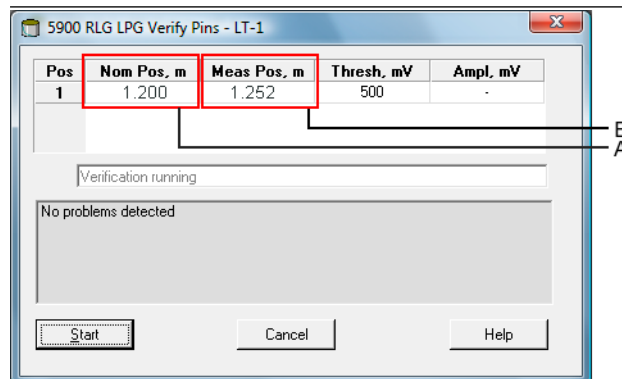

- A. Nominal position
- B. Measured position

5. Ensure that the Nominal Position of the Verification Pin appears.
6. In the *LPG Verify Pins* window, click the **Start** button to start the verification process. When verification is finished, the position measured by the level gauge appears in the *Measured Position* field.
7. Note the position of the Verification Pin that is presented in the *Measured Position* field.

8. If the position deviates from the Nominal Position, return to the *LPG Configure Pins* window and enter the measured position in the *Nominal Position* field.

Note

The nominal position that was entered the first time refers to the mechanical distance. The measured position refers to the electrical distance which is the distance “seen” by the level gauge.

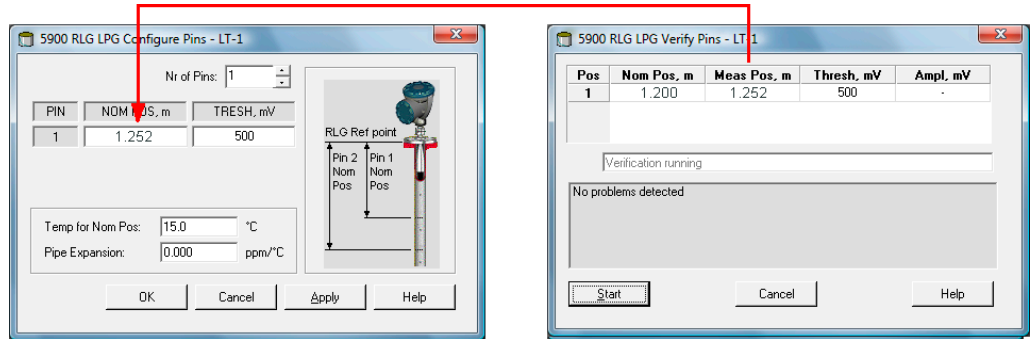

9. Repeat [Step 4](#) to [#unique_145/unique_145_Connect_42_Step7](#) until the message Successful Verification appears, indicating that Nominal Position corresponds to Measured Position.

Choose correction method

There are several options available depending on gas mixture in the tank.

Procedure

1. In the *LPG Setup* window click the **Correction** button to open the *LPG Correction* window:

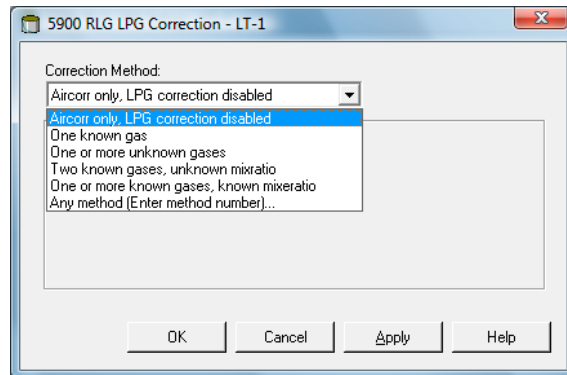

2. Choose one of the following correction methods:

Option	Description
Air Correction, LPG correction disabled	This method should only be used when there is no vapor in the tank, i.e. when the tank is empty and contains air only. It is used in the initial step when calibrating the Rosemount 5900S.
One known gas	This method may be used when there is only one gas type in the tank. It provides the highest accuracy among the different correction methods. Note that even small amounts of another gas reduces the accuracy.
One or more unknown gases	Use this method for hydrocarbons, for example Propane/ Buthane, when the exact mixture is not known.
Two gases with unknown mixratio	This method is suitable for a mixture of two gases even if the mixratio is not known.
One or more known gases with known mixratio	This method may be used when there is a well known mixture of up to 4 products in the tank.

Now the Rosemount 5900S level gauge is ready to measure the product level when the tank is put into operation.

4.7 Calibration using WinSetup

The Calibrate function is a Rosemount TankMaster WinSetup tool that lets you adjust a Rosemount 5900S level gauge in order to minimize the offset between actual (hand dipped) product levels and the values measured by the level gauge. By using the Calibrate function you can optimize measurement performance over the whole measurement range from the top to the bottom of the tank.

The Calibration function calculates the Calibration Distance based on fitting a straight line to the deviations between hand dipped levels and levels measured by the transmitter.

The Calibration function is specially suitable for a Rosemount 5900S with Still-pipe Array Antenna. The radar propagation velocity is affected by the still-pipe. Based on the pipe inner diameter, the Rosemount 5900S automatically compensates for the pipe influence. Since the average pipe diameter may be difficult to determine accurately, a minor calibration is often needed. The Calibrate function automatically calculates a Correction Factor in order to optimize the Rosemount 5900S measurements along the still-pipe.

4.7.1 Hand dipping

Follow these instructions when you make hand dip measurements:

Prerequisites

Only one person should perform manual ullage measurements in order to guarantee good repeatability between measurements.

Use only one tape for the calibration. The tape should be made of steel and calibrated by an approved testing institute. It must also be free from bends and kinks. The thermal expansion factor and calibration temperature shall also be provided.

A dip hatch should be available close to the level gauge. If the dip hatch is far away from the level gauge, differences in roof movements may result in large errors.

Procedure

1. Hand dip until three consecutive readings within 1 mm are obtained.
2. Correct the tape according to the calibration record.
3. Note the hand dipped ullage and the gauge level reading simultaneously

4.7.2 Calibration procedure

Prerequisites

Do not calibrate when

- the tank is being emptied or filled
- agitators are running
- when there are windy conditions
- when there is foam on the product surface

The calibration procedure includes the following steps:

Procedure

1. Record the hand dipped ullage values and the corresponding values measured by the level gauge.
2. Enter the hand dipped level values and the level gauge values into the WinSetup *Calibration Data* window (see [To enter calibration data](#)).
3. Inspect the resulting calibration graph and, if necessary, exclude measurement points which should not be used in the adjustment calculation.

4.7.3 To enter calibration data

Prerequisites

Make sure that the following information is available when you intend to use the **Calibrate** function in Rosemount TankMaster WinSetup:

- A list of hand dipped ullage values.
- A list of level values measured by the Rosemount 5900S that correspond to the hand dipped ullage/level values.

Procedure

1. In the Rosemount TankMaster WinSetup workspace window select the Rosemount 5900S level gauge to be calibrated.
2. Click the right mouse button and choose **Calibrate**, or choose **Calibrate** from the **Service/Devices** menu.

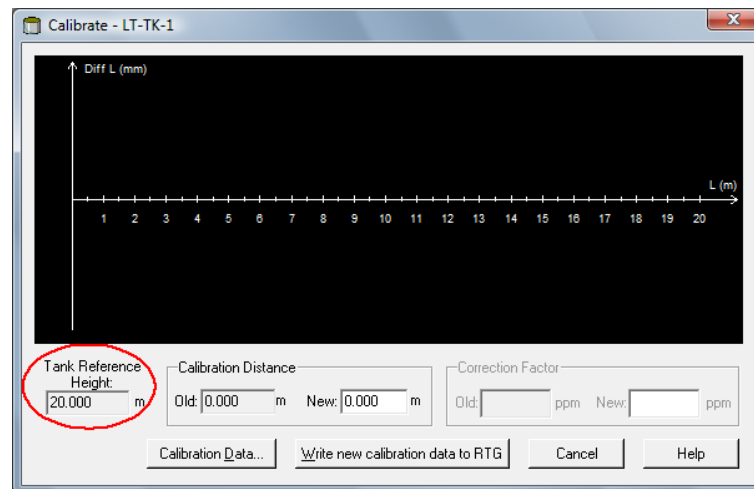

3. The *Calibrate* window is empty before any data is entered. Ensure that the gauge communicates properly with TankMaster by verifying that the Tank Reference Height appears in the lower left corner.
4. Click the **Calibration Data** button.

Figure 4-12: Calibration Data Window

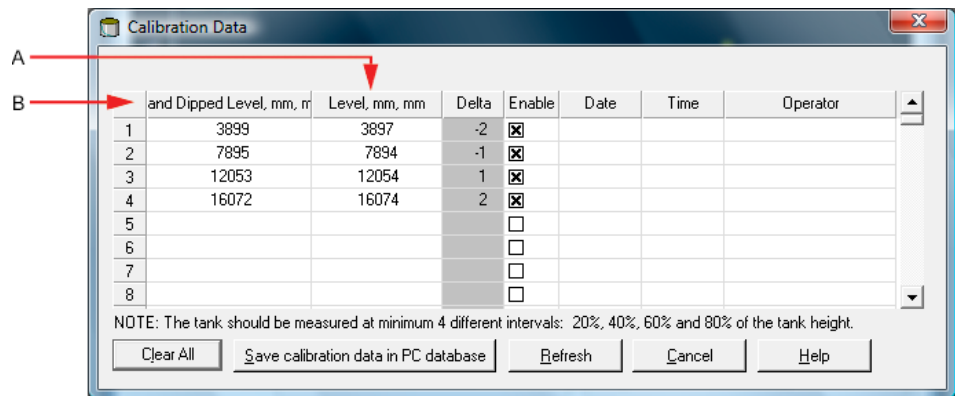

- A. Level gauge
- B. Hand dip

5. Enter hand dipped level values and the corresponding levels measured by the Rosemount 5900S level gauge. It is recommended that the hand dipped levels are based on the average value of three consecutive measurements within 1 mm. For further information see [Hand dipping](#).

Note

Measurement unit mm is used in the *Calibration Data* window.

6. Click the **Refresh** button. Now WinSetup calculates the deviations between hand dipped and measured levels.
7. Click the **Save Calibration Data in PC Database** button in order to save the entered values and return to the *Calibrate* window.

The *Calibrate* window displays a straight line fitted through measurement points that represent the difference between hand dipped level values, and values measured by the level gauge. For still pipe antennas a sloping line is displayed, otherwise the line is horizontal. The slope is due to the linear impact by the still pipe on the microwave velocity of propagation.

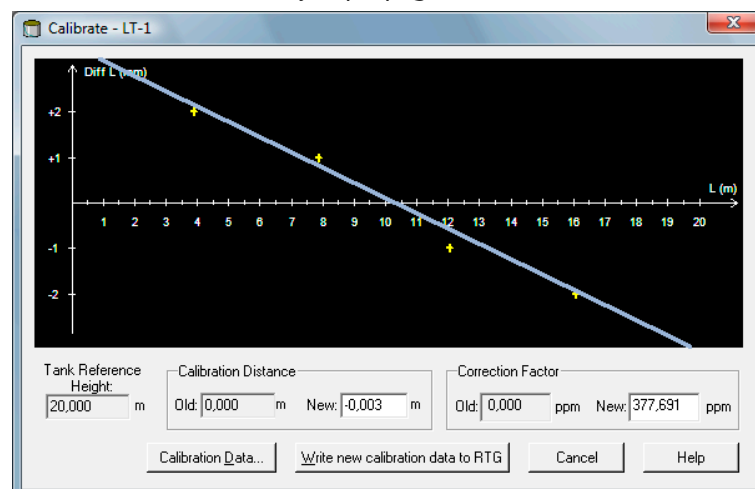

8. Check that the line fits well to the measurement points. If a point deviates significantly from the line, it can be excluded from the calculations. Open the **Calibration Data** window (click the **Calibration Data** button) and uncheck the corresponding check box in the **Enable** column.
9. Click the **Write new calibration data to RTG** button to save the current calibration data to the level gauge database registers.

Note

By clicking the **Write new calibration data to RTG** button, the Level values in the *Calibration Data* window are recalculated and the old Calibration Data is replaced.

Now you can check the calibration result in the *Calibrate* window again:

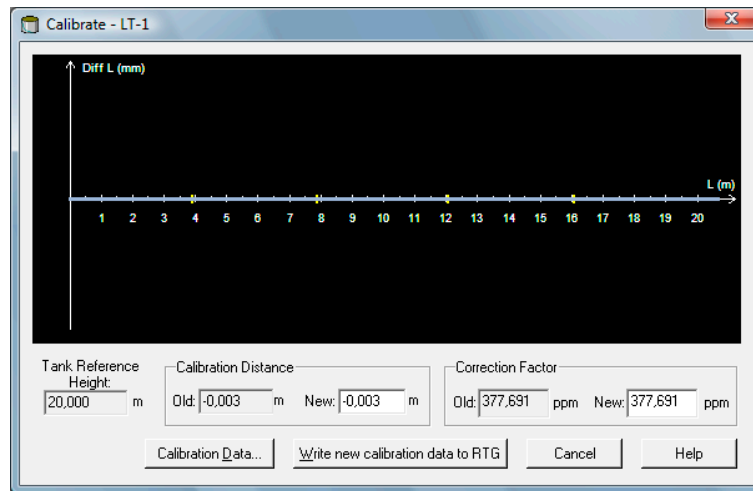

Note that all measured values are adjusted according to the calculated Calibration Distance and Correction Factor. In the *Calibration Data* window you can also see that the level values measured by the Rosemount 5900S gauge are adjusted. Of course, the hand dipped levels are unaltered.

Hand Dipped Level, mm, nr	Level, mm, mm	Delta	Enable	Date	Time	Operator
1	3899	3899	0	<input checked="" type="checkbox"/>		
2	7895	7895	0	<input checked="" type="checkbox"/>		
3	12053	12053	0	<input checked="" type="checkbox"/>		
4	16072	16072	0	<input checked="" type="checkbox"/>		
5				<input type="checkbox"/>		
6				<input type="checkbox"/>		
7				<input type="checkbox"/>		
8				<input type="checkbox"/>		

NOTE: The tank should be measured at minimum 4 different intervals: 20%, 40%, 60% and 80% of the tank height.

Note

Do not change the Calibration Distance in the *Properties/Tank Geometry* window when calibration is finished.

4.8 FOUNDATION™ Fieldbus overview

This section covers basic configuration procedures for the Rosemount 5900S Radar Level Gauge with FOUNDATION Fieldbus.

For detailed information about FOUNDATION Fieldbus technology and function blocks used in the Rosemount 5900S Series, refer to [FOUNDATION™ Fieldbus Block Information](#) and the FOUNDATION Fieldbus Blocks [Reference Manual](#) (Document No. 00809-0100-4783).

4.8.1 FOUNDATION™ Fieldbus block operation

Function blocks within the fieldbus device perform the various functions required for process control. Function blocks perform process control functions, such as Analog Input (AI) functions, as well as Proportional-Integral Derivative (PID) functions. The standard function blocks provide a common structure for defining function block inputs, outputs, control parameters, events, alarms, and modes, and combining them into a process that can be implemented within a single device or over the fieldbus network. This simplifies the identification of characteristics that are common to function blocks.

In addition to function blocks, fieldbus devices contain two other block types to support the function blocks. These are the resource block and the transducer block.

Resource blocks contain the hardware specific characteristics associated with a device; they have no input or output parameters. The algorithm within a resource block monitors and controls the general operation of the physical device hardware. There is only one resource block defined for a device.

Transducer blocks connect function blocks to local input/output functions. They read sensor hardware and write to effector (actuator) hardware.

Resource block

The resource block contains diagnostic, hardware, electronics, and mode handling information. There are no linkable inputs or outputs to the resource block.

Measurement transducer block (TB1100)

The Measurement transducer block contains device information including diagnostics and the ability to configure, set to factory defaults and restart the level gauge.

Register transducer block (TB1200)

The register transducer block allows a service engineer to access all database registers in the device.

Advanced configuration transducer block (TB1300)

The Advanced Configuration transducer block contains parameters for setup and configuration of the advanced level measurement and echo tracking functions.

Volume transducer block (TB1400)

The Volume transducer block contains parameters for configuration of volume calculations.

LPG transducer block (TB1500)

The LPG transducer block contains parameters for setup and configuration of the LPG calculations, and for verification and status of the corrections.

Analog Input block

Figure 4-13: Analog Input Block

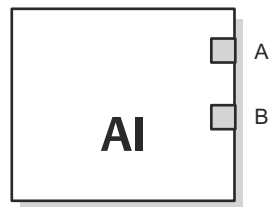

- A. *OUT_D = Discrete output that signals a selected alarm condition*
- B. *OUT = The block output value and status*

The Analog Input (AI) function block processes field device measurements and makes them available to other function blocks. The output value from the AI block is in engineering units and contains a status indicating the quality of the measurement. The measuring device may have several measurements or derived values available in different channels. Use the channel number to define the variable that the AI block processes and passes on to linked blocks. For further information refer to [Analog Input block](#) and [Analog Input block](#).

PID block

The PID Function block combines all of the necessary logic to perform proportional/integral/derivative (PID) control. The block supports mode control, signal scaling and limiting, feed forward control, override tracking, alarm limit detection, and signal status propagation.

The block supports two forms of the PID equation: Standard and Series. You can choose the appropriate equation using the MATHFORM parameter. The Standard ISA PID equation is the default selection.

Input Selector block

The Input Selector (ISEL) function block can be used to select the first good, Hot Backup, maximum, minimum, or average of as many as eight input values and place it at the output. The block supports signal status propagation.

Arithmetic block

The Arithmetic (ARTH) function block provides the ability to configure a range extension function for a primary input. It can also be used to compute nine different arithmetic functions.

Signal Characterizer block

The Signal Characterizer (SGCR) function block characterizes or approximates any function that defines an input/output relationship. The function is defined by configuring as many as twenty X,Y coordinates. The block interpolates an output value for a given input value using the curve defined by the configured coordinates. Two separate analog input signals

can be processed simultaneously to give two corresponding separate output values using the same defined curve.

Integrator Block

The Integrator (INT) function block integrates one or two variables over time.

This block will accept up to two inputs, has six options how to totalize the inputs, and two trip outputs. The block compares the integrated or accumulated value to pre-trip and trip limits and generates discrete output signals when the limits are reached.

Control Selector Block

The Control Selector function block selects one of two or three inputs to be the output. The inputs are normally connected to the outputs of PID or other function blocks. One of the inputs would be considered Normal and the other two overrides.

Output Splitter Block

The Output Splitter function block provides the capability to drive two control outputs from a single input. It takes the output of one PID or other control block to control two valves or other actuators.

Analog Output Block

Figure 4-14: Analog-Output Block

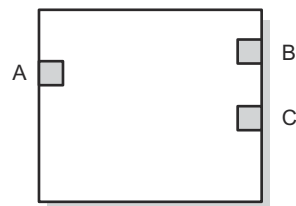

- A. *CAS_IN = The remote setpoint value from another function block*
- B. *BKCAL_OUT = The value and status required by the BKCAL_IN input of another block to prevent reset windup and to provide bumpless transfer to closed loop control.*
- C. *OUT = The block output value and status*

The Analog Output function block accepts an output value from a field device and assigns it to a specified I/O channel. For further information refer to “Analog Output block” on page 242 and “Analog Output block” on page 126.

Function block summary

The following function blocks are available for the Rosemount 5900S Series:

- Analog Input (AI)
- Analog Output (AO)
- Proportional/Integral/Derivative (PID)
- Signal Characterizer (SGCR)
- Integrator (INT)
- Arithmetic (ARTH)

- Input Selector (ISEL)
- Control Selector (CS)
- Output Splitter (OS)

4.9 Device capabilities

4.9.1 Link Active Scheduler

The Rosemount 5900S can be designated to act as the backup Link Active Scheduler (LAS) in the event that the LAS is disconnected from the segment. As the backup LAS, the Rosemount 5900S will take over the management of communications until the host is restored.

The host system may provide a configuration tool specifically designed to designate a particular device as a backup LAS. Otherwise, this can be configured manually.

4.9.2 Capabilities

Virtual Communication Relationship (VCRs)

There are a total of 20 VCRs. One is permanent and 19 are fully configurable by the host system. 40 link objects are available.

Table 4-2: Communication Parameters

Network Parameter	Value
Slot Time	8
Maximum Response Delay	5
Minimum Inter PDU Delay	8

Block Execution Times

Table 4-3: Execution Times

Block	Execution time (ms)
Analog Input (AI)	10
Analog Output (AO)	10
Proportional/Integral/Derivative (PID)	15
Signal Characterizer (SGCR)	10
Integrator (INT)	10
Arithmetic (ARTH)	10
Input Selector (ISEL)	10
Control Selector (CS)	10
Output Splitter (OS)	10

4.10 General block information

4.10.1 Modes

Changing modes

⚠ To change the operating mode, set the `MODE_BLK.TARGET` to the desired mode. After a short delay, the parameter `MODE_BLOCK.ACTUAL` should reflect the mode change if the block is operating properly.

Permitted modes

It is possible to prevent unauthorized changes to the operating mode of a block. To do this, configure `MODE_BLOCK.PERMITTED` to allow only the desired operating modes. It is recommended to always select OOS as one of the permitted modes.

Types of modes

For the procedures described in this manual, it will be helpful to understand the following modes:

AUTO	The functions performed by the block will execute. If the block has any outputs, these will continue to update. This is typically the normal operating mode.
Out of Service (OOS)	The functions performed by the block will not execute. If the block has any outputs, these will typically not update and the status of any values passed to downstream blocks will be "BAD". To make some changes to the configuration of the block, change the mode of the block to OOS. When the changes are complete, change the mode back to AUTO.
MAN	In this mode, variables that are passed out of the block can be manually set for testing or override purposes.
Other types of modes	Other types of modes are Cas, RCas, ROut, IMan and LO. Some of these may be supported by different function blocks in the Rosemount 5900S. For more information, see the Function Block manual (Document No. 00809-0100-4783).

Note

When an upstream block is set to OOS, this will impact the output status of all downstream blocks. The figure below depicts the hierarchy of blocks:

Figure 4-15: Hierarchy of Blocks

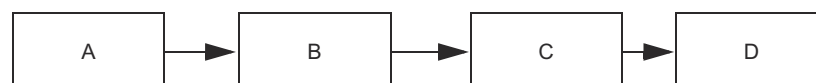

- A. Resource Block
 - B. Transducer Block
 - C. Analog Input (AI Block)
 - D. Other function blocks
-

4.10.2 Block instantiation

The Rosemount 5900S supports the use of function block instantiation. Then the number of blocks and block types can be defined to match specific application needs. The number of blocks that can be instantiated is only limited by the amount of memory within the device and the block types that are supported by the device. Instantiation does not apply to standard device blocks like the Resource and transducer blocks.

By reading the parameter “FREE_SPACE” in the Resource block you can determine how many blocks you can instantiate. Each block that you instantiate takes up 4.6% of the “FREE_SPACE”.

Block instantiation is done by the host control system or configuration tool, but not all hosts implement this functionality. Please refer to your specific host or configuration tool manual for more information.

4.10.3 Factory configuration

The following fixed configuration of function blocks is provided:

Table 4-4: Function Blocks for the Rosemount 5900S

Function Block	Index	Default Tag	Available
Analog Input ⁽¹⁾	1600	AI 1600	Fixed
Analog Input	1700	AI 1700	Fixed
Analog Input	1800	AI 1800	Fixed
Analog Input	1900	AI 1900	Fixed
Analog Input	2000	AI 2000	Fixed
Analog Input	2100	AI 2100	Fixed
Analog Output ⁽²⁾	2200	AO 2200	Default, deletable
Analog Output	2300	AO 2300	Default, deletable
PID	2400	PID 2400	Default, deletable
Control Selector	2500	CSEL 2500	Default, deletable
Output Splitter	2600	OSPL 2600	Default, deletable
Signal Characterizer	2700	CHAR 2700	Default, deletable
Integrator	2800	INTEG 2800	Default, deletable
Arithmetic	2900	ARITH 2900	Default, deletable
Input Selector	3000	ISEL 3000	Default, deletable

(1) See [Factory supplied AI blocks](#) for more information.

(2) See [Analog Output block](#) for more information.

4.11 Analog Input block

4.11.1 Configure the AI block

⚠ A minimum of four parameters are required to configure the AI block. The parameters are described below with example configurations shown at the end of this section.

CHANNEL

Select the channel that corresponds to the desired sensor measurement:

Table 4-5: AI Block Channels for the Rosemount 5900S

AI Block Parameter	TB Channel Value	Process Variable
Level	1	CHANNEL_LEVEL
Distance	2	CHANNEL_DISTANCE
Level Rate	3	CHANNEL_LEVELRATE
Signal Strength	4	CHANNEL_SIGNAL_STRENGTH
Internal Temperature	5	CHANNEL_HOUSING_TEMPERATURE
Volume	6	CHANNEL_VOLUME

L_TYPE

The L_TYPE parameter defines the relationship of the transmitter measurement (Level, Distance, Level Rate, Signal Strength, Internal Temperature, and Volume) to the desired output of the AI Block. The relationship can be direct, indirect, or indirect root.

- Direct** Select direct when the desired output will be the same as the transmitter measurement (level, distance, level rate, signal strength, volume, and internal temperature).
- Indirect** Select indirect when the desired output is a calculated measurement based on the transmitter measurement (level, distance, level rate, signal strength, volume, and internal temperature). The relationship between the transmitter measurement and the calculated measurement will be linear.
- Indirect square root** Select indirect square root when the desired output is an inferred measurement based on the transmitter measurement and the relationship between the sensor measurement and the inferred measurement is square root.

XD_SCALE and OUT_SCALE

The XD_SCALE and OUT_SCALE each include three parameters: 0%, 100%, and engineering units. Set these based on the L_TYPE:

- L_TYPE is direct** When the desired output is the measured variable, set the XD_SCALE to represent the operating range of the process. Set OUT_SCALE to match XD_SCALE.

L_TYPE is indirect When an inferred measurement is made based on the sensor measurement, set the XD_SCALE to represent the operating range that the sensor will see in the process. Determine the inferred measurement values that correspond to the XD_SCALE 0 and 100% points and set these for the OUT_SCALE.

L_TYPE is indirect square root When an inferred measurement is made based on the transmitter measurement and the relationship between the inferred measurement and sensor measurement is square root, set the XD_SCALE to represent the operating range that the sensor will see in the process. Determine the inferred measurement values that correspond to the XD_SCALE 0 and 100% points and set these for the OUT_SCALE.

Engineering units

Note

To avoid configuration errors, only select engineering units for XD_SCALE and OUT_SCALE that are supported by the device.

Related information

[Supported units](#)

4.11.2 Factory supplied AI blocks

The Rosemount 5900S is supplied with six pre-configured AI blocks according to [Table 4-6](#). The block configuration can be changed if needed.

Table 4-6: Factory Supplied AI Blocks for the Rosemount 5900S

AI Block	Channel	L-Type	Units
1	CHANNEL_LEVEL	Direct	Meter
2	CHANNEL_DISTANCE	Direct	Meter
3	CHANNEL_LEVELRATE	Direct	Meter per hour
4	CHANNEL_SIGNAL_STRENGTH	Direct	mV
5	CHANNEL_HOUSING_TEMPERATURE	Direct	deg C
6	CHANNEL_VOLUME	Direct	m ³

4.11.3 Modes

The AI Function Block supports three modes of operation as defined by the MODE_BLK parameter:

- Manual (Man)** The block output (OUT) may be set manually.
- Automatic (Auto)** OUT reflects the analog input measurement or the simulated value when simulation is enabled.
- Out of Service (O/S)** The block is not processed. FIELD_VAL and PV are not updated and the OUT status is set to Bad: Out of Service. The BLOCK_ERR parameter shows Out of Service. In this mode, you can make

changes to all configurable parameters. The target mode of a block may be restricted to one or more of the supported modes.

4.11.4 Application example

Level value

A Rosemount 5900S Radar Level Gauge measures the product level in a 15 m high tank.

Table 4-7: Analog Input Function Block Configuration for a Rosemount 5900S Level Gauge

Parameter	Configured Values
L_TYPE	Direct
XD_SCALE	EU_0=0. EU_100=15. Engineering unit=meter.
OUT_SCALE	EU_0=0. EU_100=15. Engineering unit=meter.
CHANNEL	CH1: Level

4.11.5 Simulation

To perform lab test of process variables and alerts, you can either change the mode of the AI block to manual and adjust the output value, or you can enable simulation through the configuration tool and manually enter a value for the measurement value and its status. In both cases, you must first set the SIMULATE switch (1) on the field device to the ON position.

With simulation enabled, the actual measurement value has no impact on the OUT value or the status.

Figure 4-16: Simulation Switch

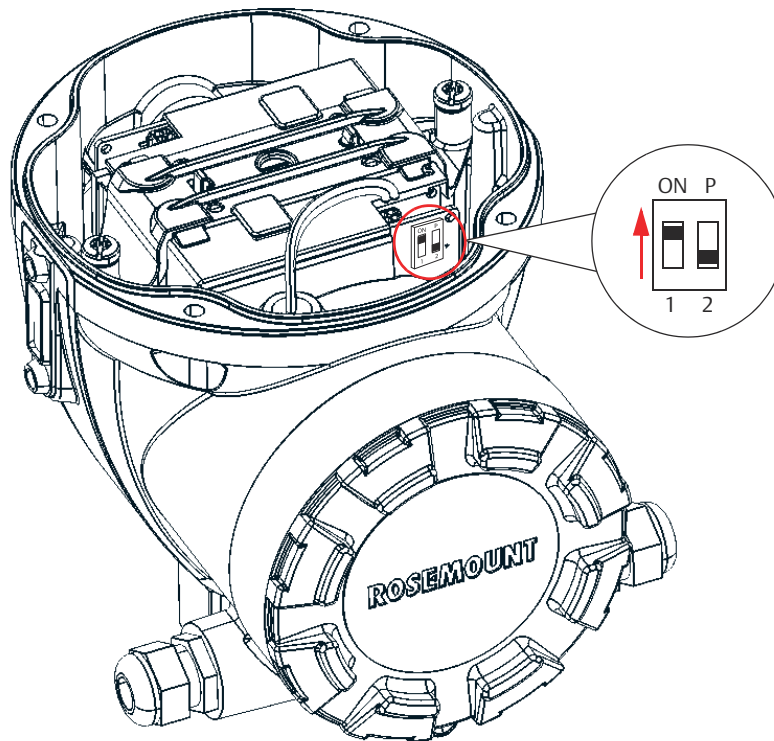

4.11.6 Process alarms

Process Alarm detection is based on the OUT value. Configure the alarm limits of the following standard alarms:

- High (HI_LIM)
- High high (HI_HI_LIM)
- Low (LO_LIM)
- Low low (LO_LO_LIM)

To avoid alarm chattering when the variable is oscillating around the alarm limit, an alarm hysteresis in percent of the PV span can be set using the ALARM_HYS parameter.

The priority of each alarm is set in the following parameters:

- HI_PRI
- HI_HI_PRI
- LO_PRI
- LO_LO_PRI

4.11.7 Alarm priority

Alarms are grouped into five levels of priority:

Table 4-8: Alarm Levels of Priority

Priority number	Priority description
0	The alarm condition is not used.
1	An alarm condition with a priority of 1 is recognized by the system, but is not reported to the operator.
2	An alarm condition with a priority of 2 is reported to the operator, but does not require operator attention (such as diagnostics and system alerts).
3-7	Alarm conditions of priority 3 to 7 are advisory alarms of increasing priority.
8-15	Alarm conditions of priority 8 to 15 are critical alarms of increasing priority.

4.11.8 Status handling

Normally, the status of the PV reflects the status of the measurement value, the operating condition of the I/O card, and any active alarm condition. In Auto mode, OUT reflects the value and status quality of the PV. In Man mode, the OUT status constant limit is set to indicate that the value is a constant and the OUT status is Good.

The Uncertain - EU range violation status is always set, and the PV status is set high- or low-limited if the sensor limits for conversion are exceeded.

In the STATUS_OPTS parameter, you can select from the following options to control the status handling:

BAD if Limited	Sets the OUT status quality to Bad when the value is higher or lower than the sensor limits.
Uncertain if Limited	Sets the OUT status quality to Uncertain when the value is higher or lower than the sensor limits.
Uncertain if in Manual mode	The status of the Output is set to Uncertain when the mode is set to Manual.

Note

The instrument must be in Manual or Out of Service mode to set the status option. The AI block only supports the BAD if Limited option. Unsupported options are not grayed out; they appear on the screen in the same manner as supported options.

4.11.9 Advanced features

The AI function block provided with Rosemount™ fieldbus devices provides added capability through the addition of the following parameters:

- ALARM_TYPE** Allows one or more of the process alarm conditions detected by the AI function block to be used in setting its OUT_D parameter.
- OUT_D** Discrete output of the AI function block based on the detection of process alarm condition(s). This parameter may be linked to other function blocks that require a discrete input based on the detected alarm condition.
- VAR_SCAN** Time period in seconds over which the variability index (VAR_INDEX) is computed.
- VAR_INDEX** Process variability index measured as the integral of average absolute error between PV and its mean value over the previous evaluation period. This index is calculated as a percent of OUT span and is updated at the end of the time period defined by VAR_SCAN.

4.11.10 Filtering

The filtering feature changes the response time of the device to smooth variations in output readings caused by rapid changes in input. You can adjust the filter time constant (in seconds) using the PV_FTIME parameter. Set the filter time constant to zero to disable the filter feature.

Figure 4-17: Analog Input Function Block Timing Diagram

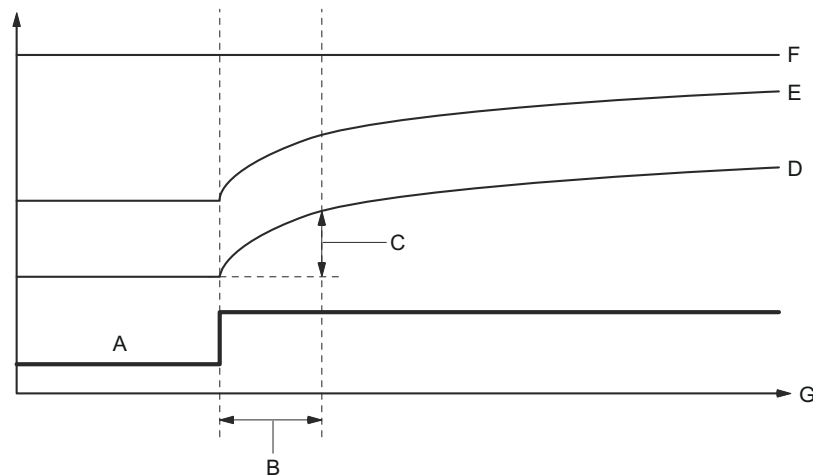

- A. FIELD_VAL
- B. PV_FTIME
- C. 63% of Change
- D. PV
- E. OUT (mode in auto)
- F. OUT (mode in man)
- G. Time (seconds)

4.11.11 Signal conversion

You can set the signal conversion type with the Linearization Type (L_TYPE) parameter. You can view the converted signal (in percent of XD_SCALE) through the FIELD_VAL parameter.

You can choose from direct or indirect signal conversion with the L_TYPE parameter.

$$\text{FIELD_VAL} = \frac{100 \times (\text{Channel Value} - \text{EU}^*\text{@0\%})}{(\text{EU}^*\text{@100\%} - \text{EU}^*\text{@0\%})}$$

* XD_SCALE values

Direct

Direct signal conversion allows the signal to pass through the accessed channel input value (or the simulated value when simulation is enabled).

$$\text{PV} = \text{Channel Value}$$

Indirect

Indirect signal conversion converts the signal linearly to the accessed channel input value (or the simulated value when simulation is enabled) from its specified range (XD_SCALE) to the range and units of the PV and OUT parameters (OUT_SCALE).

$$\text{PV} = \left(\frac{\text{FIELD_VAL}}{100} \right) \times (\text{EU}^{**}\text{@100\%} - \text{EU}^{**}\text{@0\%}) + \text{EU}^{**}\text{@0\%}$$

** OUT_SCALE values

Indirect square root

Indirect Square Root signal conversion takes the square root of the value computed with the indirect signal conversion and scales it to the range and units of the PV and OUT parameters.

$$\text{PV} = \sqrt{\left(\frac{\text{FIELD_VAL}}{100} \right)} \times (\text{EU}^{**}\text{@100\%} - \text{EU}^{**}\text{@0\%}) + \text{EU}^{**}\text{@0\%}$$

** OUT_SCALE values

When the converted input value is below the limit specified by the LOW_CUT parameter, and the Low Cutoff I/O option (IO_OPTS) is enabled (True), a value of zero is used for the converted value (PV). This option is useful to eliminate false readings when the differential pressure measurement is close to zero, and it may also be useful with zero-based measurement devices such as flowmeters.

Note

Low Cutoff is the only I/O option supported by the AI block. You can set the I/O option in Manual or Out of Service mode only.

4.12 Analog Output block

The Rosemount 5900S is supplied with two pre-configured Analog Output (AO) blocks according to [Table 4-10](#). The block configuration can be changed if needed. See [Analog Output block](#) for more information.

CHANNEL

Select the channel that corresponds to the desired sensor measurement:

Table 4-9: AO Block Channels for the Rosemount 5900S

AO Block Parameter	TB Channel Value	Process Variable
Vapor Temperature	7	CHANNEL_VAPOR_TEMPERATURE
Pressure	8	CHANNEL_PRESSURE
User Defined	9	CHANNEL_USERDEFINED
Tank Temperature	10	CHANNEL_TANK_TEMPERATURE

Table 4-10: Factory Supplied AO Blocks for the Rosemount 5900S

AO Block	Channel	Units
1	CHANNEL_VAPOR_TEMPERATURE	deg C
2	CHANNEL_PRESSURE	bar

XD_SCALE

The XD_SCALE includes three parameters: 0%, 100%, and engineering units. Set the XD_SCALE engineering unit to represent the unit for the AO block channel value.

4.12.1 Application example

LPG

A Rosemount 5900S Radar Level Gauge configured for LPG measurements with temperature and pressure sensors.

Figure 4-18: Function Block Configuration for Rosemount 5900S in LPG Applications

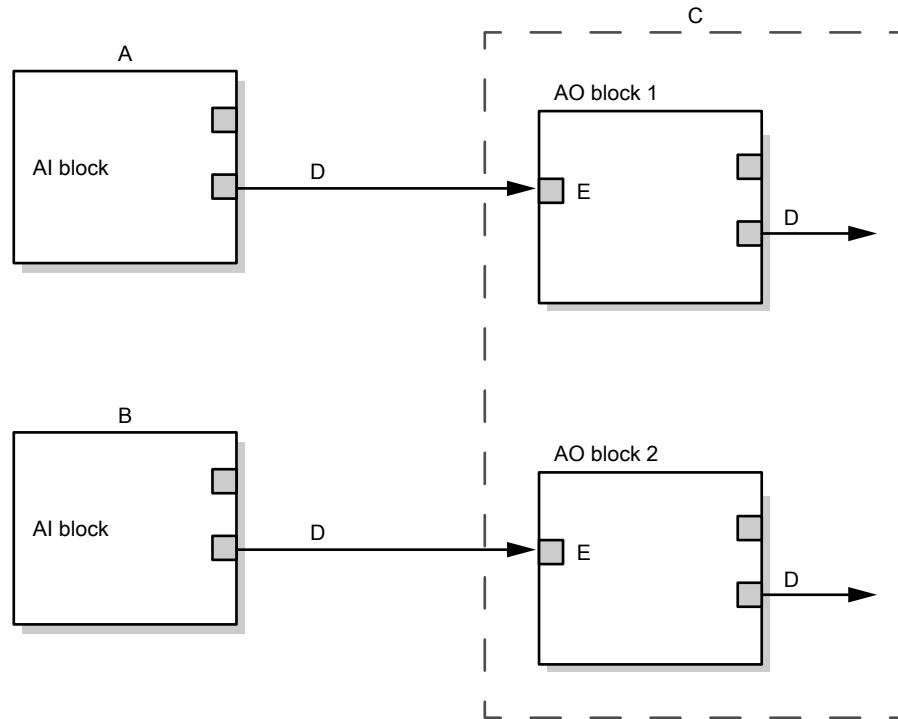

- A. Temperature device
- B. Pressure device (Rosemount 2051)
- C. Rosemount 5900S Radar Level Gauge
- D. OUT=Block output and status
- E. CAS_IN=Remote setpoint value from another function block

4.13 Resource block

4.13.1 FEATURES and FEATURES_SEL

The FEATURES parameter is read only and defines which features are supported by the Rosemount 5900S. Below is a list of FEATURES the Rosemount 5900S supports.

FEATURES_SEL is used to turn on any of the supported features that are found in the FEATURES parameter. The default setting of the Rosemount 5900S is HARD W LOCK. Choose one or more of the supported features if any.

UNICODE

All configurable string variables in the Rosemount 5900S, except tag names, are octet strings. Either ASCII or Unicode may be used. If the configuration device is generating Unicode octet strings, you must set the Unicode option bit.

REPORTS

The Rosemount 5900S supports alert reports. The Reports option bit must be set in the features bit string to use this feature. If it is not set, the host must poll for alerts. If this bit is set, the transmitter will actively report alerts.

SOFT W LOCK and HARD W LOCK

Inputs to the security and write lock functions include the hardware security switch, the hardware and software write lock bits of the FEATURE_SEL parameter, and the WRITE_LOCK parameter.

The WRITE_LOCK parameter prevents modification of parameters within the device except to clear the WRITE_LOCK parameter. During this time, the block will function normally updating inputs and outputs and executing algorithms. When the WRITE_LOCK condition is cleared, a WRITE_ALM alert is generated with a priority that corresponds to the WRITE_PRI parameter.

The FEATURE_SEL parameter enables the user to select a hardware or software write lock or no write lock capability. To enable the hardware security function, enable the HARDW_LOCK bit in the FEATURE_SEL parameter. When this bit has been enabled the WRITE_LOCK parameter becomes read only and will reflect the state of the hardware switch.

In order to enable the software write lock, the SOFTW_LOCK bit must be set in the FEATURE_SEL parameter. Once this bit is set, the WRITE_LOCK parameter may be set to “Locked” or “Not Locked.” Once the WRITE_LOCK parameter is set to “Locked” by the software lock, all user requested writes shall be rejected.

Table 4-11 displays all possible configurations of the WRITE_LOCK parameter.

Table 4-11: Write_Lock Parameter

FEATURE_SEL HARDW_LOC K bit	FEATURE_SEL SOFTW_LOCK bit	SECURITY SWITCH	WRITE_LOCK	WRITE_LOCK Read/Write	Write access to blocks
0 (off)	0 (off)	NA	1 (unlocked)	Read only	All
0 (off)	1 (on)	NA	1 (unlocked)	Read/Write	All

Table 4-11: Write_Lock Parameter (continued)

FEATURE_SEL HARDW_LOCK K bit	FEATURE_SEL SOFTW_LOCK bit	SECURITY SWITCH	WRITE_LOCK	WRITE_LOCK Read/Write	Write access to blocks
0 (off)	1 (on)	NA	2 (locked)	Read/Write	None
1 (on)	0 (off) ⁽¹⁾	0 (unlocked)	1 (unlocked)	Read only	All
1 (on)	0 (off)	1 (locked)	2 (locked)	Read only	None

(1) The hardware and software write lock select bits are mutually exclusive and the hardware select has the highest priority. When the HARDW_LOCK bit is set to 1 (on), the SOFTW_LOCK bit is automatically set to 0 (off) and is read only.

4.13.2 MAX_NOTIFY

The MAX_NOTIFY parameter value is the maximum number of alert reports that the resource can have sent without getting a confirmation, corresponding to the amount of buffer space available for alert messages. The number can be set lower, to control alert flooding, by adjusting the LIM_NOTIFY parameter value. If LIM_NOTIFY is set to zero, then no alerts are reported.

4.13.3 Field diagnostic alerts

The Resource Block acts as a coordinator for Field Diagnostic alerts. There are four alert parameters (FD_FAIL_ALM, FD_OFFSPEC_ALM, FD_MAINT_ALM, and FD_CHECK_ALM) which contain information regarding some of the device errors which are detected by the transmitter software.

There is a FD_RECOMMEN_ACT parameter which is used to display the recommended action text for the highest priority alarm. FD_FAIL_ALM has the highest priority followed by FD_OFFSPEC_ALM, FD_MAINT_ALM, and FD_CHECK_ALM which has the lowest priority.

Failure alerts

A Failure alert indicates a condition within a device that will make the device or some part of the device non-operational. This implies that the device is in need of repair and must be fixed immediately. There are five parameters associated with Failure alerts specifically, they are described below.

FD_FAIL_MAP

This parameter maps conditions to be detected as active for this alarm category. Thus the same condition may be active in all, some, or none of the four alarm categories. The parameter contains a list of conditions in the device which makes the device non-operational that will cause an alarm to be sent. Below is a list of the conditions with the highest priority first. This priority is not the same as the FD_FAIL_PRI parameter described below. It is hard coded within the device and is not user configurable.

1. Software Incompatibility Error
2. Memory Failure - FF I/O Board

3. Device Error
4. Internal Communication Failure
5. Electronics Failure

FD_FAIL_MASK

This parameter will mask any of the failed conditions listed in FD_FAIL_MAP. A bit on means that the condition is masked out from alarming and being broadcast to the host through the alarm parameter.

FD_FAIL_PRI

Designates the alarming priority of the FD_FAIL_ALM, see [Alarm priority](#). The default is 0 and the recommended values are between 8 and 15.

FD_FAIL_ACTIVE

This parameter displays which of the conditions is active.

FD_FAIL_ALM

Alarm indicating a condition within a device which makes the device non-operational.

Out of specification alerts

An Out of Specification alert indicates that the device operates out of the specified measurement range. If the condition is ignored, the device will eventually fail. There are five parameters associated with Out of Specification alerts, they are described below.

FD_OFFSPEC_MAP

The FD_OFFSPEC_MAP parameter contains a list of conditions indicating that the device or some part of the device operates out of specification. Below is a list of the conditions with the highest priority first. This priority is not the same as the FD_OFFSPEC_PRI parameter described below. It is hard coded within the device and is not user configurable.

Below is a list of the conditions⁽¹²⁾:

1. Device Major Information
2. Device Warning

FD_OFFSPEC_MASK

The FD_OFFSPEC_MASK parameter will mask any of the failed conditions listed in FD_OFFSPEC_MAP. A bit on means that the condition is masked out from alarming and being broadcast to the host through the alarm parameter.

FD_OFFSPEC_PRI

This parameter designates the alarming priority of the FD_OFFSPEC_ALM, see [Alarm priority](#). The default is 0 and the recommended values are 3 to 7.

FD_OFFSPEC_ACTIVE

The FD_OFFSPEC_ACTIVE parameter displays which of the conditions is detected as active.

(12) Note that Out of Specification alerts are not enabled by default.

FD_OFFSPEC_ALM

An alarm indicating that the device operates out of the specified measurement range. If the condition is ignored, the device will eventually fail.

Maintenance required alerts

A Maintenance required alert indicates that the device or some part of the device needs maintenance soon. If the condition is ignored, the device will eventually fail. There are five parameters associated with Maintenance Required alerts, they are described below.

FD_MAINT_MAP

The FD_MAINT_MAP parameter contains a list of conditions indicating that the device or some part of the device needs maintenance soon. The priority is not the same as the MAINT_PRI parameter described below. It is hard coded within the device and is not user configurable.

Note that maintenance alarms are not enabled by default for the Rosemount 5900S.

Below is a list of the conditions:

1. Auxiliary Device Measurement Close to Limit

FD_MAINT_MASK

The FD_MAINT_MASK parameter will mask any of the failed conditions listed in FD_MAINT_MAP. A bit on means that the condition is masked out from alarming and being broadcast to the host through the alarm parameter.

FD_MAINT_PRI

FD_MAINT_PRI designates the alarming priority of the FD_MAINT_ALM, see [Alarm priority](#). The default is 0 and the recommended values are 3 to 7.

FD_MAINT_ACTIVE

The FD_MAINT_ACTIVE parameter displays which of the conditions is active.

FD_MAINT_ALM

An alarm indicating that the device needs maintenance soon. If the condition is ignored, the device will eventually fail.

Function Check alerts

A Function Check alert indicates that the device is temporary non-valid due to some activities, for example maintenance, on the device.

There are five parameters associated with Function Check alerts, they are described below.

FD_CHECK_MAP

The FD_CHECK_MAP parameter contains a list of informative conditions that do not have a direct impact on the primary functions of the device. Below is a list of the conditions:

1. Check function

FD_CHECK_MASK

The FD_CHECK_MASK parameter will mask any of the failed conditions listed in FD_CHECK_MAP. A bit on means the condition is masked out from alarming and being broadcast to the host through the alarm parameter.

FD_CHECK_PRI

FD_CHECK_PRI designates the alarming priority of the FD_CHECK_ALM, see [Alarm priority](#). The default is 0 and the recommended values are 1 or 2.

FD_CHECK_ACTIVE

The FD_CHECK_ACTIVE parameter displays which of the conditions is active.

FD_CHECK_ALM

FD_CHECK_ALM is an alarm indicating that the device output is temporary invalid due to on-going work on the device.

4.13.4 Recommended actions for alerts

The RECOMMENDED_ACTION parameter displays a text string that will give a recommended course of action to take based on which type and which specific event of the alerts is active (See [Table 6-10](#)).

4.14 475 Field Communicator Menu Tree

The Rosemount 5900S can be configured by using a 475 Field Communicator. The menu tree below shows the available options for configuration and service.

Figure 4-19: Field Communicator Menu Tree

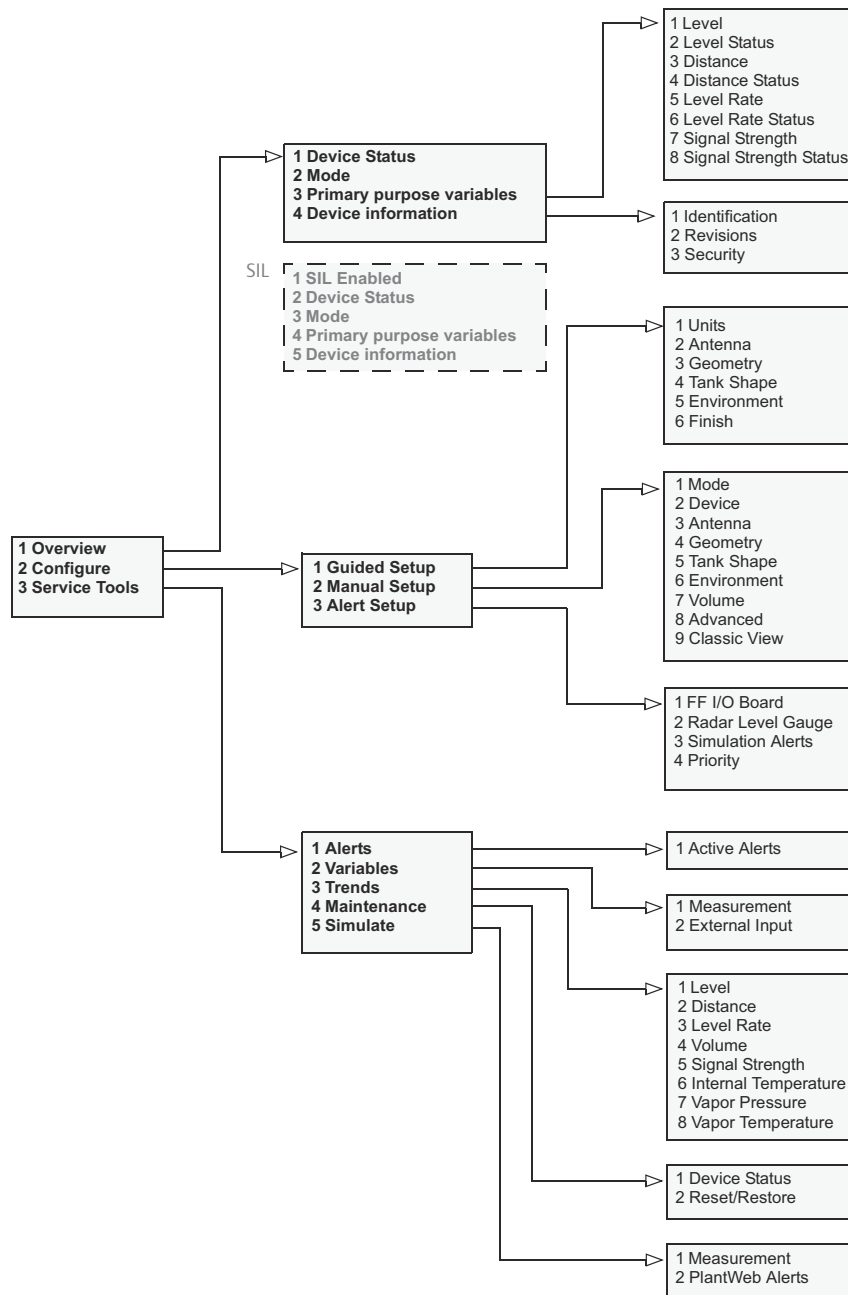

4.15 Configuration using AMS Device Manager

The Rosemount 5900S supports DD Methods to facilitate device configuration. The following description shows how to use the AMS Device Manager application to configure the Rosemount 5900S in a FOUNDATION Fieldbus system.

For more information on configuration parameters see [Basic configuration](#) and [Advanced configuration](#).

4.15.1 Starting the guided setup

To configure the Rosemount 5900S in the AMS Device Manager application:

Procedure

1. Open the **View** → **Device Connection View**.
2. Double-click the FF network icon and expand the network node to view the devices.
3. Right-click or double-click the desired gauge icon to open the list of menu options:

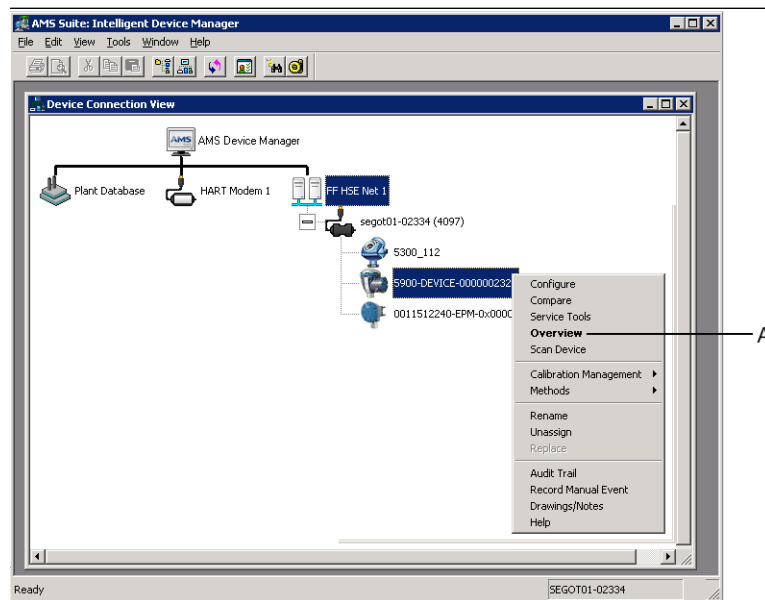

A. Overview

4. Select the **Overview** option for an overview of the current device and measurement status.

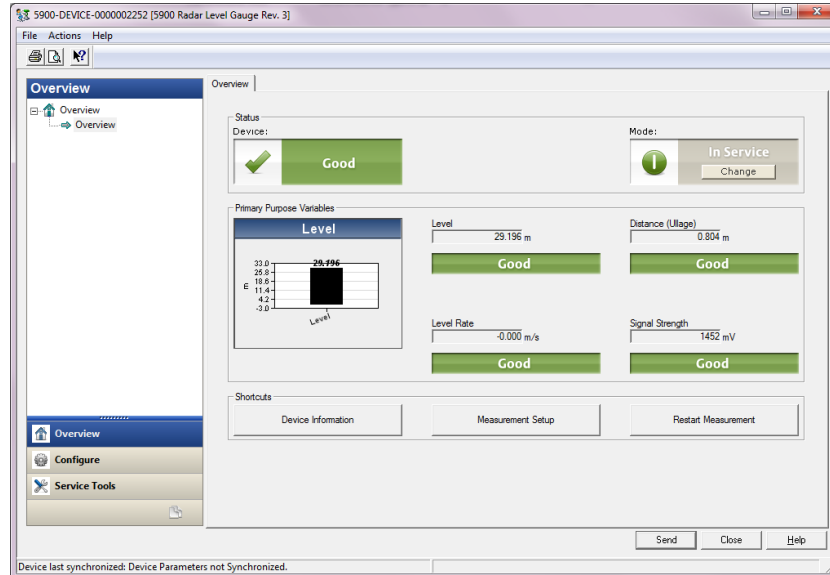

5. Click the **Change** button and set the device to **Out Of Service (OOS)** mode. In case you don't change device mode now, it will automatically be changed when starting the **Measurement Setup** wizard.
6. Do one of the following to start the configuration wizard:
 - in the *Overview* window, click the **Measurement Setup** button
 - select the **Configure** option and in the *Guided Setup* window click the **Measurement Setup** button

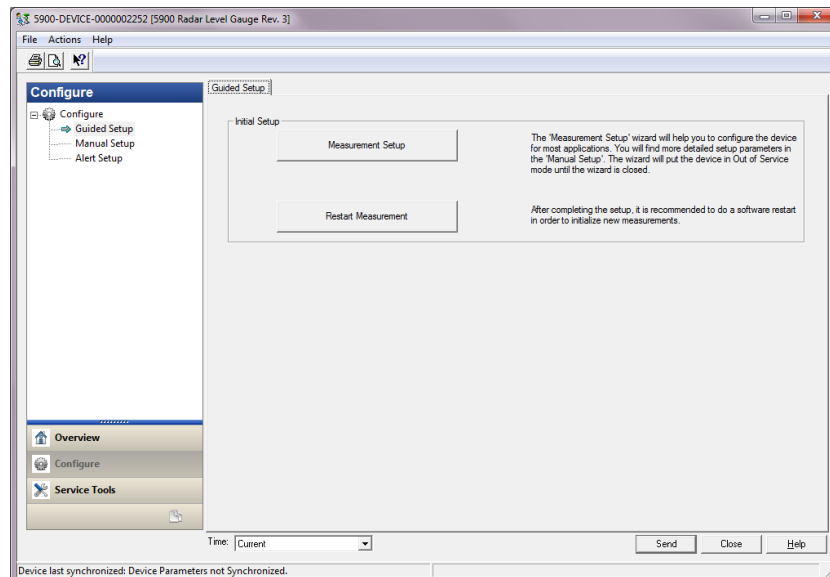

7. In case the device was not set to Out Of Service mode, a warning message will appear that the device needs to be in Out Of Service mode in order to make configuration changes. By clicking the **Next** button, the Rosemount 5900S level gauge will automatically be set to Out Of Service (OOS) mode, and the *Measurement Setup - Units* window appears.

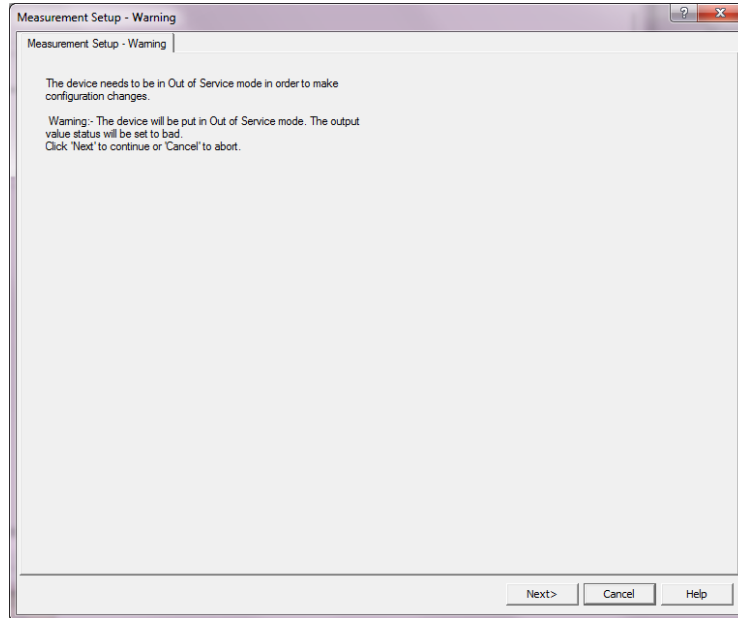

8. Click the **Next** button to proceed.

4.15.2 Measurement setup

Procedure

1. Start the Guided Setup as described in [Starting the guided setup](#).

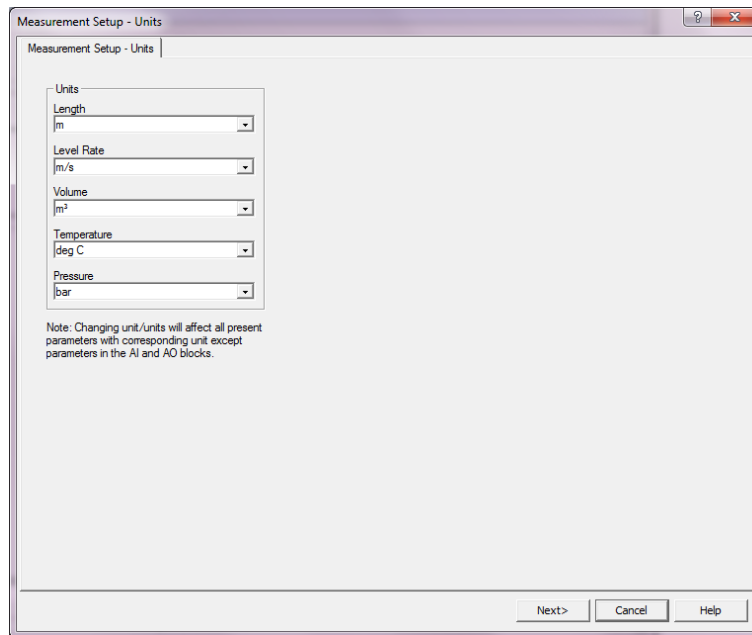

2. Choose measurement units for Length, Level Rate, Volume, Temperature, and Pressure. Note that parameters in the Analog Input and Analog Output blocks are not affected.

3. Click the **Next** button to open the *Measurement Setup - Antenna* window.

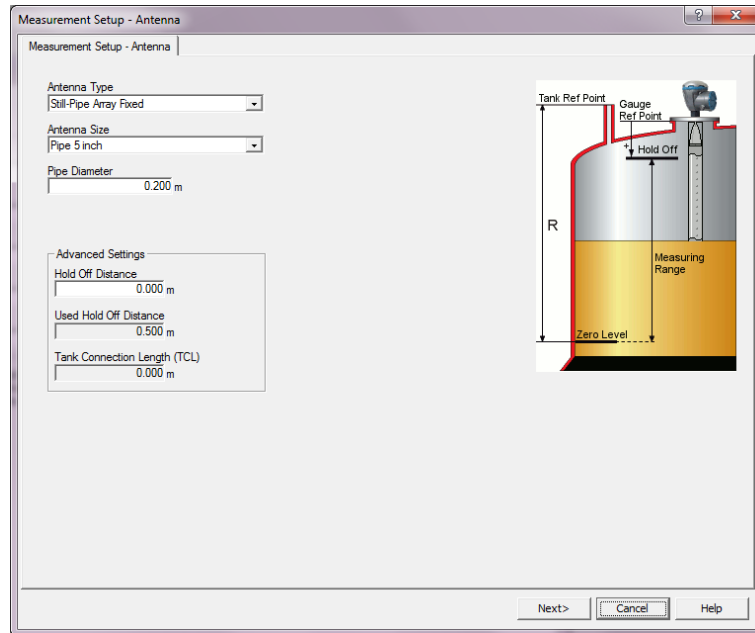

4. Choose one of the predefined Antenna Types to match the antenna attached to the Rosemount 5900S Radar Level Gauge.
5. Optional: For Still-pipe Array antennas the antenna size is also required. Sizes ranging from 5 to 12 inch are available.
6. Optional: Enter the Pipe Diameter if the Rosemount 5900S is installed in a Still-pipe.

FOUNDATION™ Fieldbus parameters:

TRANSDUCER 1100>ANTENNA_TYPE

TRANSDUCER 1100>ANTENNA_SIZE

TRANSDUCER 1100>PIPE_DIAMETER

TRANSDUCER 1100>HOLD_OFF_DIST

7. Click the **Next** button to open the *Measurement Setup - Geometry* window.

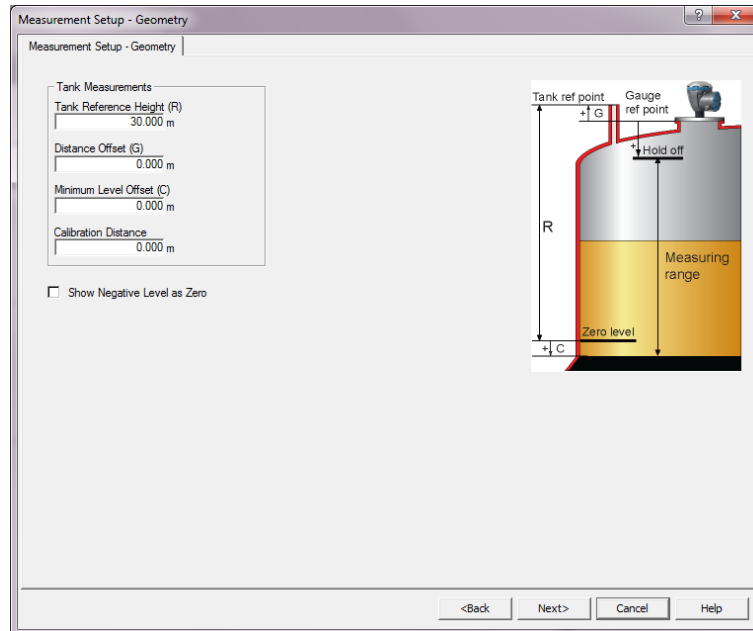

8. Tank Reference Height (R) is the distance from the Tank Reference Point to the Zero Level near the tank bottom. Ensure that this number is as accurate as possible.
9. The Reference Distance (G) is the distance between the Tank Reference Point and the Gauge Reference Point, which is located at the upper surface of the nozzle flange or manhole cover on which the gauge is mounted. G is positive if the Tank Reference Point is located above the Gauge Reference Point, otherwise G is negative.
10. The Minimum Level Distance (C) is defined as the distance between the Zero Level (Dipping Datum Point) and the minimum level (tank bottom) for the product surface. By specifying a C-distance the measuring range can be extended to the bottom of the tank.

C>0: the Rosemount 5900S presents negative level values when the product surface is below the Zero Level.

You can use the **Show negative level values as zero** check box if you wish to present product levels below the Zero Level (Datum plate) as equal to zero.

FOUNDATION Fieldbus parameters:

TRANSDUCER 1100>TANK_HEIGHT_R

TRANSDUCER 1100>OFFSET_DIST_G

TRANSDUCER 1100>BOTTOM_OFFSET_DIST_C

TRANSDUCER 1100>TANK_PRESENTATION

11. Click the **Next** button and proceed to the *Measurement Setup - Tank Shape* window:

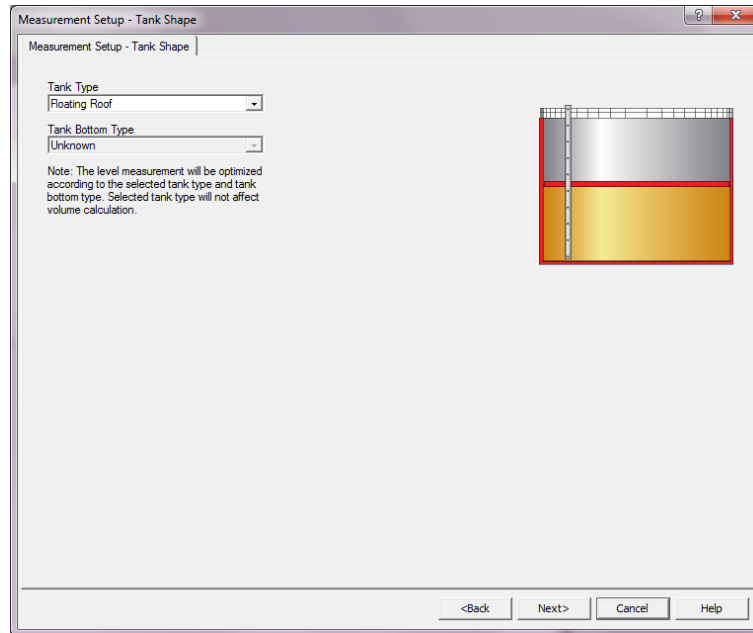

12. Select a Tank Type option that matches the actual tank. Choose **Unknown** if none of the available options is applicable.
13. Select Tank Bottom Type that matches the actual tank. Choose **Unknown** if no option is applicable.

FOUNDATION Fieldbus parameters:

TRANSDUCER 1100>TANK_SHAPE

TRANSDUCER 1100>TANK_BOTTOM_TYPE

- Click the **Next** button to open the *Measurement Setup - Environment* window.

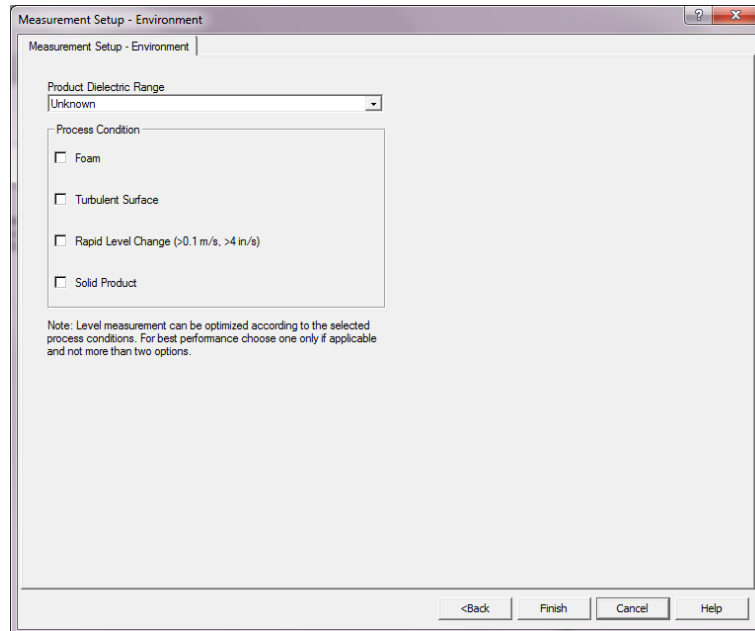

- Select check boxes that correspond to the conditions in the tank. Use as few options as possible. It is recommended that no more than two options are used simultaneously.
- Choose **Product Dielectric Range** from the drop-down list. Use the Unknown option if the correct value range is unknown or if the contents of the tank is changing on a regular basis.

FOUNDATION Fieldbus parameters:

TRANSDUCER 1100>PRODUCT_DC

TRANSDUCER 1100>TANK_ENVIRONMENT

17. Click the **Finish** button.

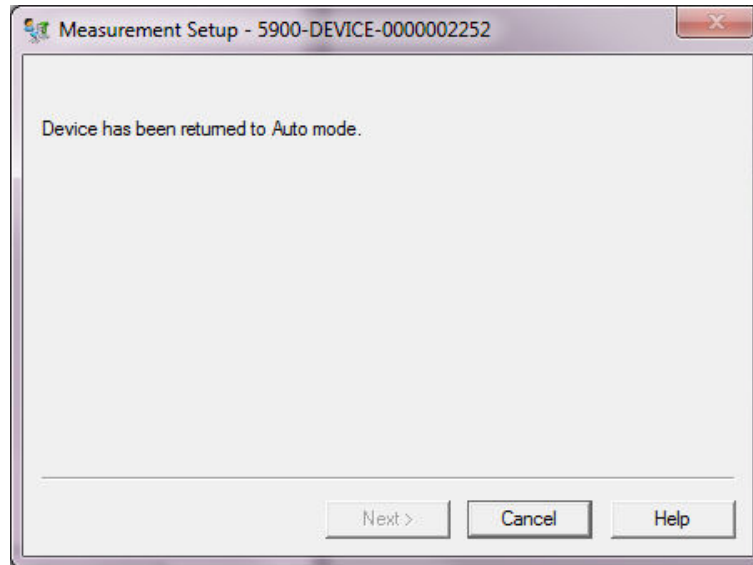

18. In the *Measurement Setup* window click the **Cancel** button and return to the **Guided Setup** tab.

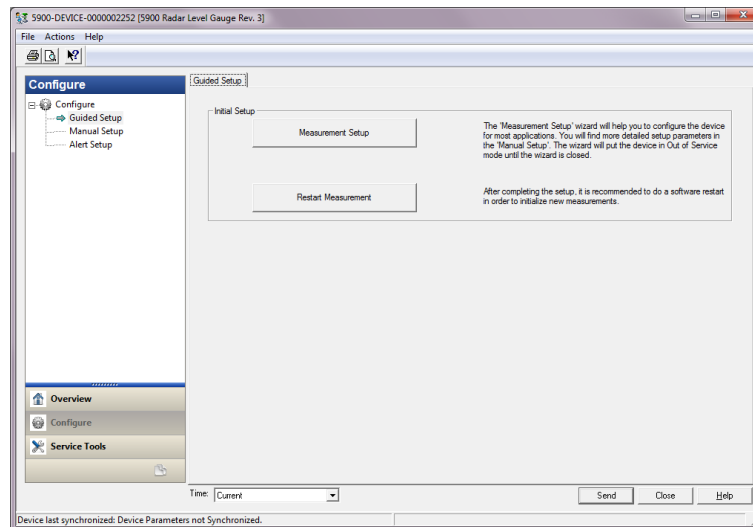

19. When the guided setup is finished, it is recommended that the Rosemount 5900S is restarted by clicking the **Restart Measurement** button⁽¹³⁾.
20. Now you can continue with volume configuration and advanced configuration if desired. See [Volume configuration](#) and [Advanced configuration](#).

(13) Restarting the Rosemount 5900S does not affect the FOUNDATION Fieldbus communication.

4.15.3 Volume configuration

To open the Volume configuration option:

Procedure

1. Open the AMS Device Manager application.
2. Open **Configure** → **Manual Setup** → **Volume**.

The Volume tab lets you configure the Rosemount 5900S for volume measurements. You can choose a calculation method based on one of the pre-defined standard tank types or the Strapping Table option. The Strapping Table can be used in case a standard tank type does not provide sufficient accuracy.

Depending on the chosen Volume Calculation Method, i.e. Ideal Sphere, Vertical or Horizontal Cylinder, you will need to specify one or both of the two parameters Tank Diameter (L1) and Tank Length (L2).

A Volume Offset parameter can be specified if you like to use a non-zero volume for the zero level. This may be useful if you would like to include the product volume below the zero level in the total volume.

Figure 4-20: Volume Configuration

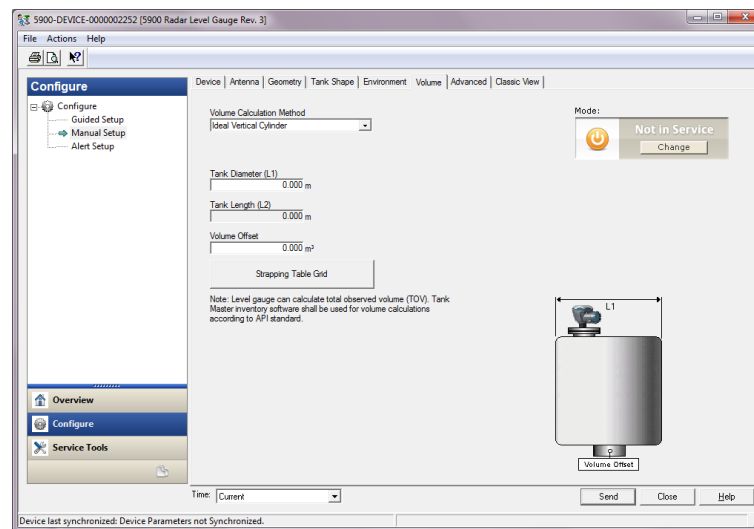

4.15.4 Advanced configuration

Several advanced configuration options are available for the Rosemount 5900S Radar Level Gauge. These may be used to optimize measurement performance for certain applications.

To find the advanced configuration options:

Procedure

1. Open the AMS Device Manager application.
2. Open **Configure** → **Manual Setup** → **Advanced**.

Figure 4-21: Advanced Configuration

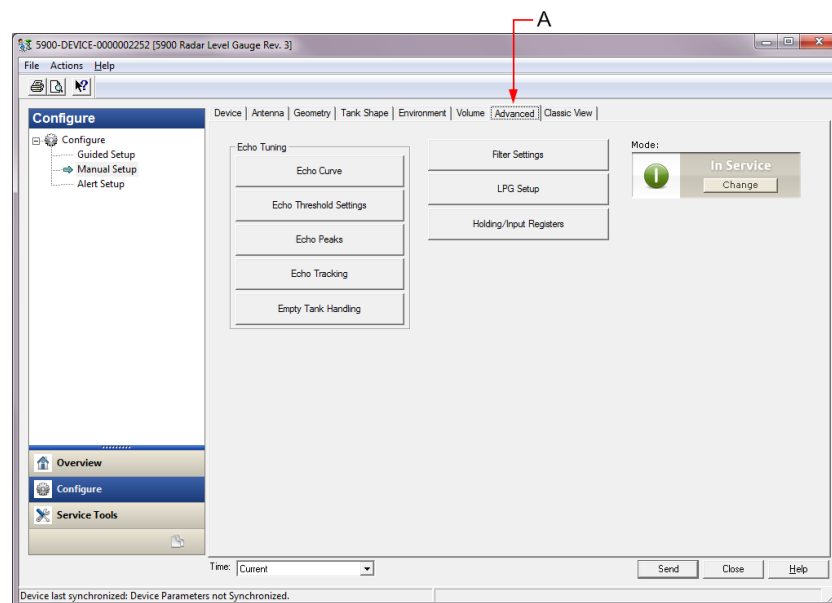

A. *Advanced*

The *Advanced Configuration* window offers several functions for optimizing the Rosemount 5900S level gauge for various measurement conditions. For example, the Echo Threshold Settings function lets you create an Amplitude Threshold table to filter out echoes from disturbing objects.

See [Advanced configuration](#) for more information on how to use various options such as Echo Curve (Tank Scan), Empty Tank Handling, Surface Echo Tracking and Filter Settings.

Echo curve

The *Echo Curve* window lets you analyze the measurement signal from a Rosemount 5900S. It allows you to view tank echoes and configure parameters to enable the gauge to distinguish between surface echoes and disturbing echoes and noise. For details see [Tank Scan](#).

Figure 4-22: Echo Curve Configuration

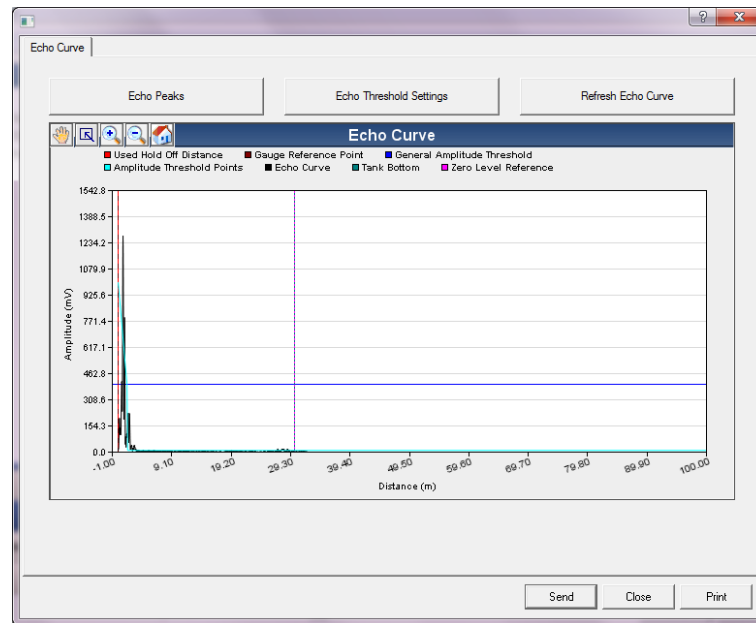

The **Echo Peaks** button lets you open the *Echo Peaks* window which allows you to register false echoes.

The **Echo Threshold Settings** button opens the *Echo Threshold Settings* window which lets you set a general amplitude threshold to filter out noise. You may also create a customized amplitude threshold curve to optimize disturbing echo filtering.

For more information see chapter “Service Functions/Tank Scan” in the Rosemount Tank Gauging [System Configuration Manual](#).

Echo threshold settings

The *Echo Threshold Settings* window lets you create a general amplitude threshold to filter out noise. You may also create a customized amplitude threshold curve to optimize disturbing echo filtering.

Figure 4-23: Echo Threshold Configuration

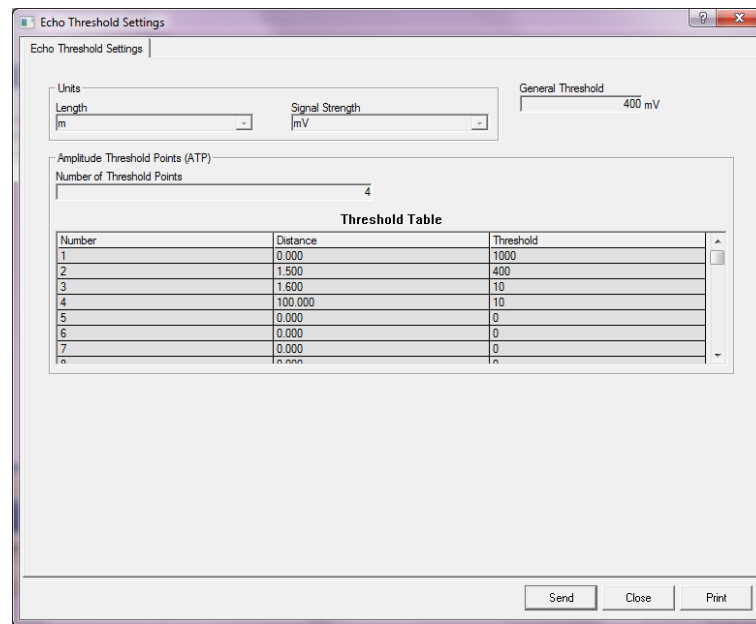

Echo peaks

The *Echo Peaks* window lets you register false echoes. You may also point out which peak is the actual product surface. This function may be useful to facilitate surface echo tracking in a tank with many disturbing objects.

When using this function you should check that registered echoes correspond to actual objects in the tank.

Figure 4-24: False Echo Registration

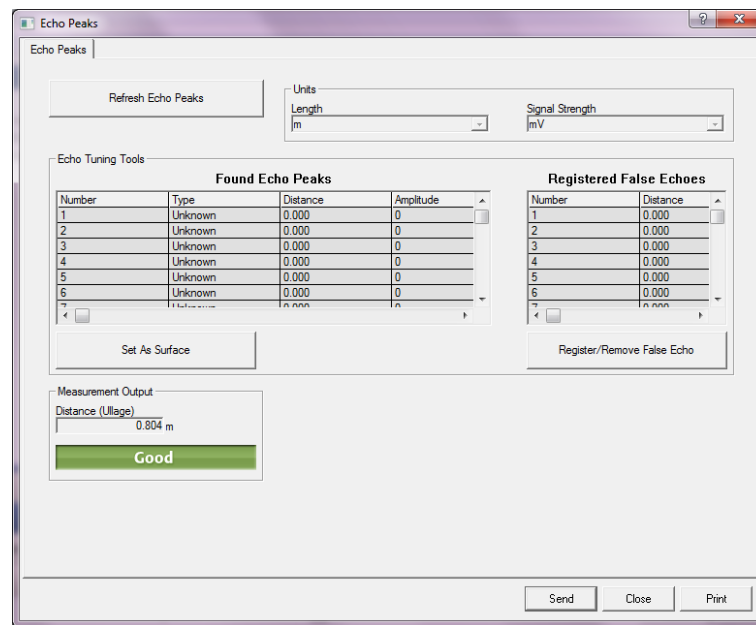

Echo tracking

The Surface Echo Tracking function can be used to eliminate problems with certain types of “ghost” echoes below the product surface. This may, for example, occur in Still-pipes as a result of multiple reflections between the pipe wall, flange and antenna. In the tank spectrum these echoes appear as amplitude peaks at various distances below the product surface.

To activate this function, ensure that there are no disturbing echoes above the product surface and select the **Always Track First Echo** check box.

Figure 4-25: Echo Tracking Configuration

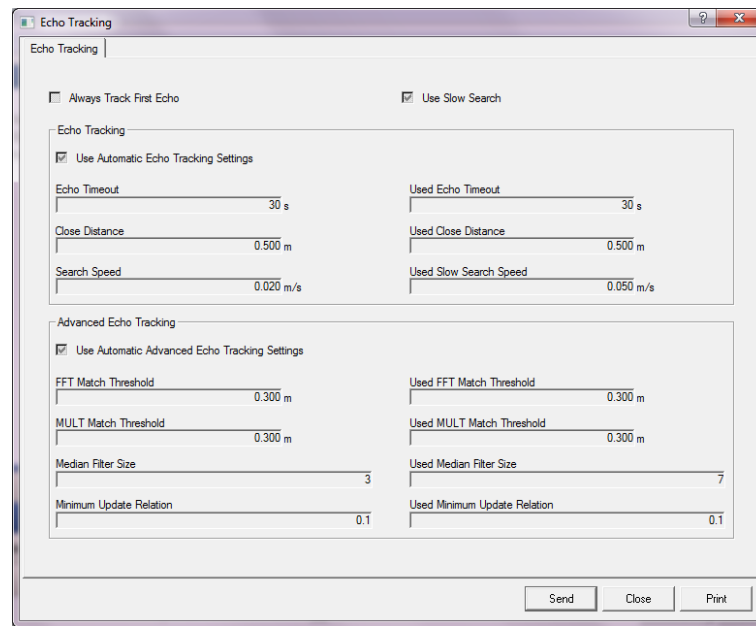

For details see [Surface Echo Tracking](#).

Empty tank handling

The Empty Tank Handling function facilitates surface tracking close to the tank bottom for products with a low dielectric constant. Such products are relatively transparent for microwaves, and strong echoes from the tank bottom may interfere with the relatively weak measurement signal from the surface. Using this function may therefore improve measurement performance when the product surface is close to the tank bottom.

In case the product surface echo is lost in the Empty Tank Detection Area close to the tank bottom, the device will enter Empty Tank state and an Invalid Level alarm is triggered.

Figure 4-26: Empty Tank Configuration

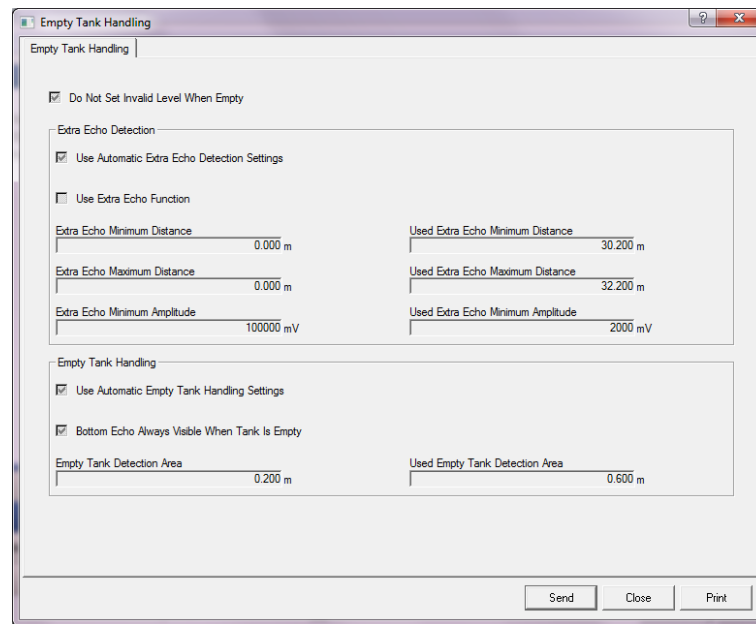

The Extra Echo Detection function is used for tanks with a dome or conical bottom shape provided the tank bottom does not produce a strong echo when the tank is empty. For tanks with a conical bottom, an echo may appear beneath the actual tank bottom when the tank is empty. If the device is not able to detect the tank bottom this function can be used to ensure that the device stays in empty tank state as long as this extra echo is present.

For further details see [Empty tank handling](#).

Filter settings

The *Filter Settings* window provides various functions for optimizing echo tracking depending on tank conditions and movement of the product surface.

Figure 4-27: Filter Settings

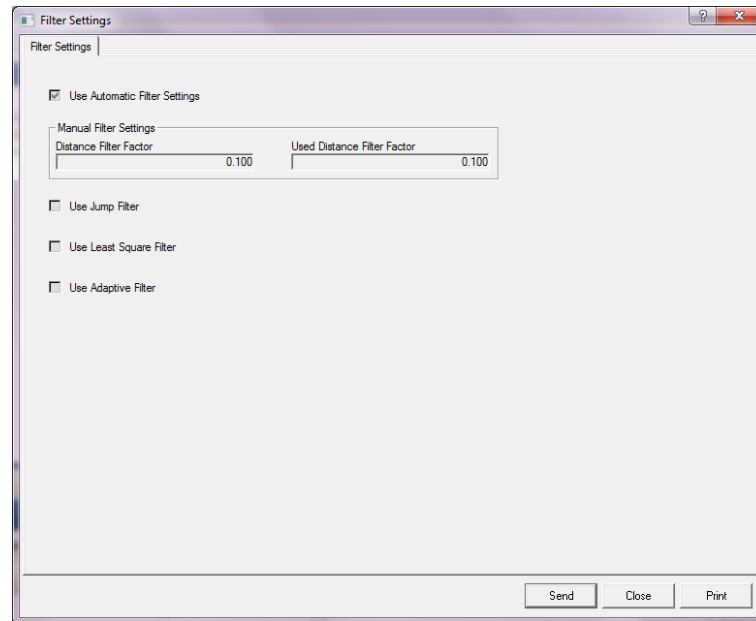

The Distance Filter Factor defines the amount of product level filtering (1 = 100%).

A low Filter Factor makes the level value steady but the device reacts slowly to level changes in the tank.

A high Filter Factor makes the device react quickly to level changes but the presented level value can sometimes be somewhat jumpy.

The Jump Filter is typically used for applications with turbulent surface and makes the echo tracking work smoother as the level passes, for example, an agitator.

The Least Square Filter provides increased accuracy for slow filling or emptying of a tank. The Least Square filter can not be used at the same time as the Adaptive Filter.

The Adaptive Filter automatically adapts to the movement of the surface level. It tracks product level fluctuations and continuously adjusts the filter grade accordingly. The filter can preferably be used in tanks in which fast tracking of level changes are important and turbulence occasionally cause unstable level readings.

4.16 Alert setup

The *Alert Setup* window allows you to configure and enable/disable alerts.

For details on how to view active alerts see [Viewing active alerts in AMS Device Manager](#).

To open the *Alert Setup* window:

Procedure

1. From the **Start** menu; open the AMS Device Manager application.
2. Open the **View** → **Device Connection View**.
3. Double-click the FF network icon and expand the network node.

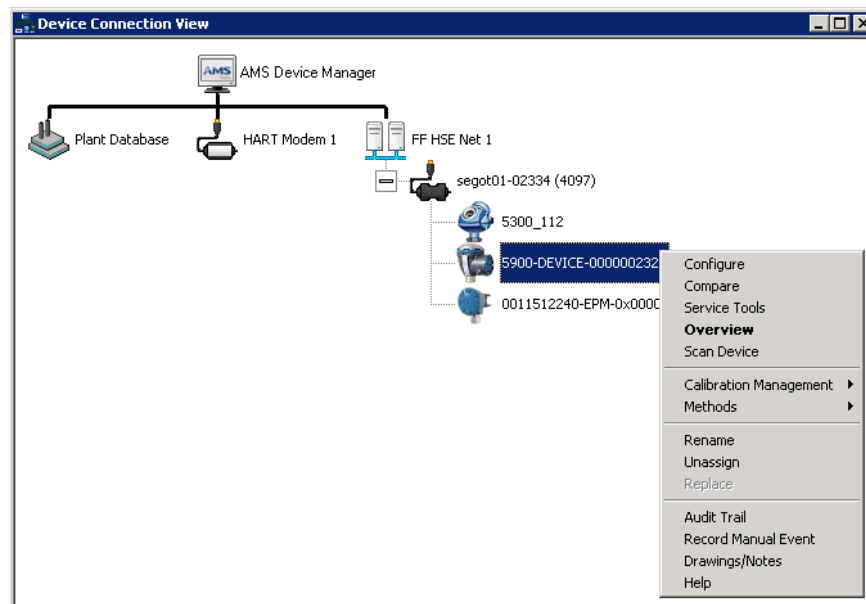

4. Right-click or double-click the desired gauge icon to open the list of menu options.
5. Click the right mouse button and choose the **Configure** option.
6. Select the **Alert Setup** option.

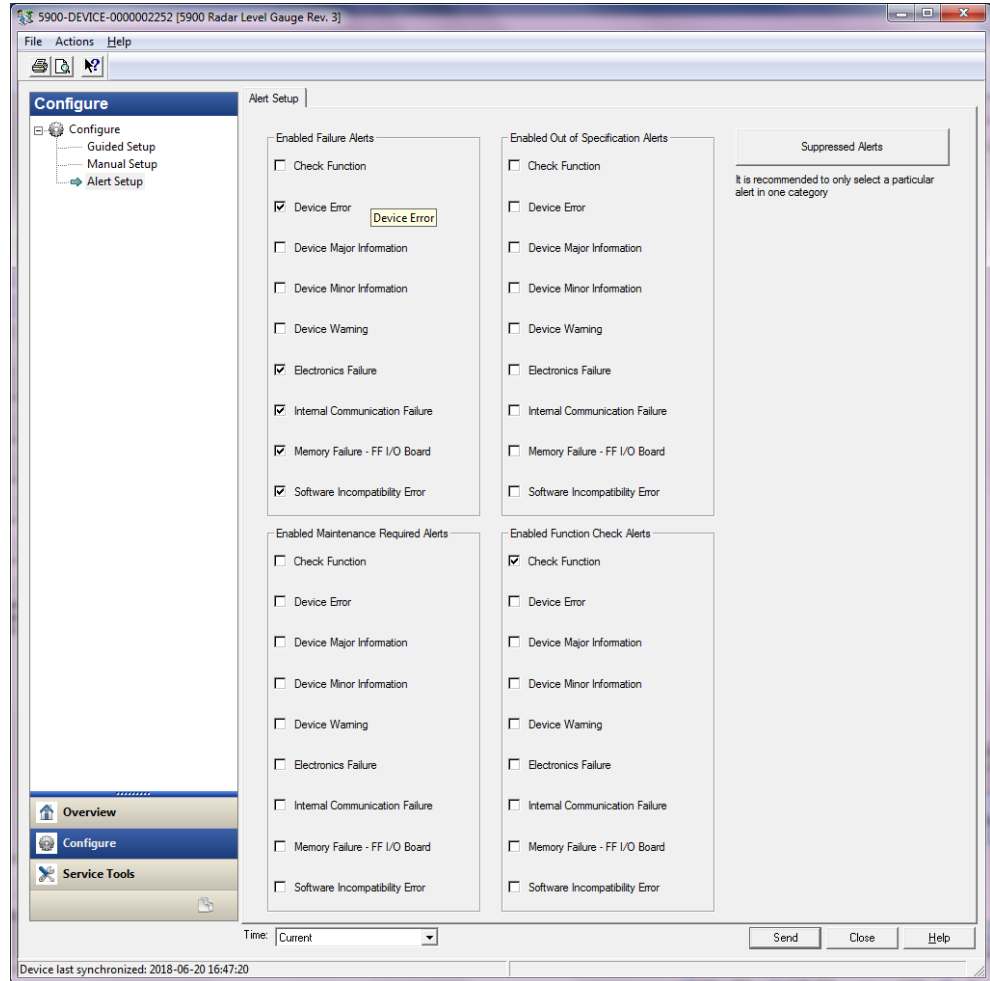

7. Configure alerts for the different error types. The first time this window is opened, the default setup of error types and alerts (Failure, Maintenance Required, Out of Specification, and Function Check) will appear, see [Alert default settings](#).
8. You may change the configuration for each error type by selecting the appropriate check box to match your requirements. Note that it is possible to map an error condition to several alert categories if desired.
9. See [Alert default settings](#) for information on the default setup for error types and alerts (Failure, Maintenance, Out of Specification, and Function Check).
10. Click the **Send** button to save the current alert setup once the configuration is finished.

4.16.1 Alert default settings

The following alert default settings are used for the Rosemount 5900. You may configure error types in a different way if you like. For example, the Device major information error is configured as a Maintenance Required alert (disabled) for the Rosemount 5900S by default. The *Alert Setup* window allows you to enable the alert as Failure, Out of Specification, Maintenance Required, or Function Check.

Table 4-12: Default Alert Configuration

Error type	Default configuration	Enabled / Disabled
Check Function	Function check alert	Enabled
Device error	Failure alert	Enabled
Device major information	Out of Specification alert	Disabled
Device minor information	Maintenance Required alert	Disabled
Device warning	Out of Specification alert	Disabled
Electronics failure	Failure alert	Enabled
Internal communication failure	Failure alert	Enabled
Memory Failure - FF I/O Board	Failure alert	Enabled
Software Incompatibility Error	Failure alert	Enabled

4.16.2 Alert simulation

When simulating alerts, only those alerts which are setup according to the default configuration will be seen, see [Alert default settings](#).

Figure 4-28: Alert Simulation Disabled

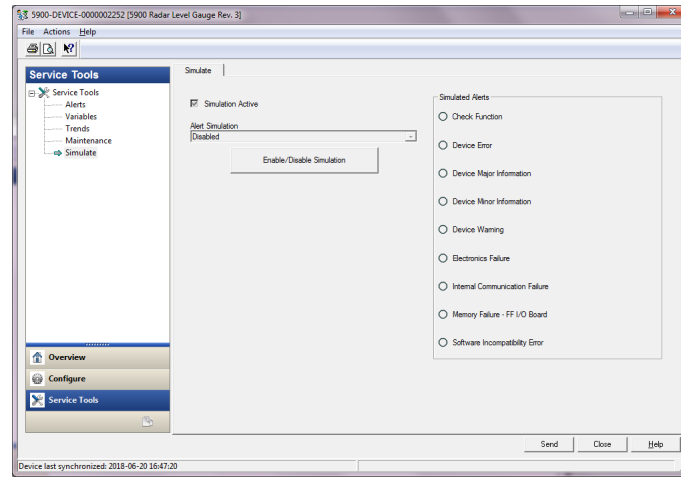
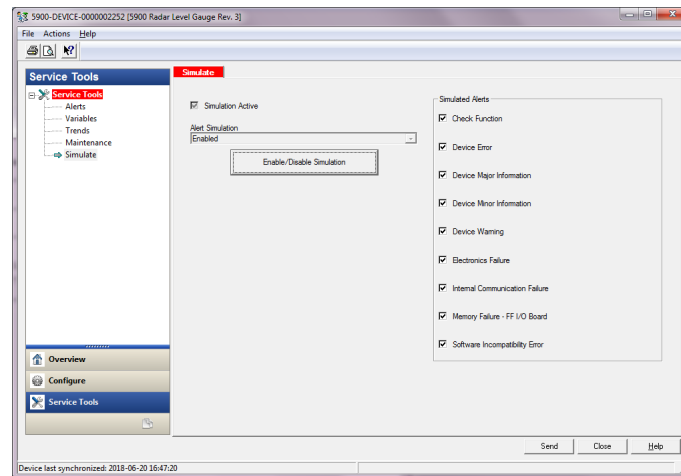

Figure 4-29: Alert Simulation Enabled



4.17 LPG Setup using DeltaV / AMS Device Manager

The Rosemount 5900S can be setup in a FOUNDATION Fieldbus system for LPG applications. DeltaV/AMS Device Manager supports configuration as described on the following pages. Prior to performing the LPG Setup it is recommended that you read [Preparations](#) for information on how to prepare a Rosemount 5900S for LPG configuration.

To configure a Rosemount 5900S for LPG applications:

Procedure

1. Open *Control Studio* or some other appropriate tool for configuration of FOUNDATION Fieldbus function blocks.

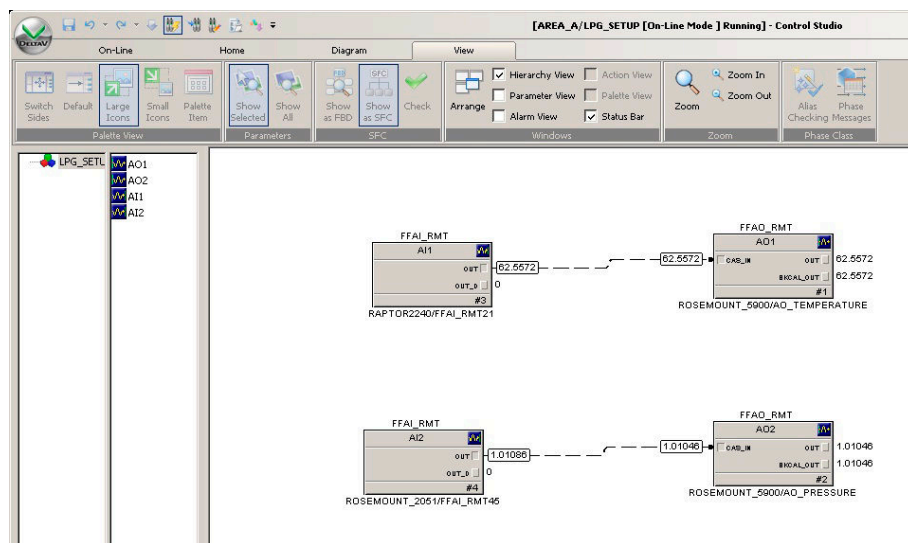

2. Ensure that the Analog Output blocks are connected to the appropriate devices for Vapor Temperature and Vapor Pressure.
3. In *DeltaV/AMS Device Manager*, open the **View** → **Device Connection View**.
4. Double-click the FF network icon and expand the network node to view the devices.
5. Right-click or double-click the Rosemount 5900S level gauge icon to open the list of menu options.
6. Choose the **Configure** option.

7. Choose **Manual Setup** and select the **Advanced** tab.

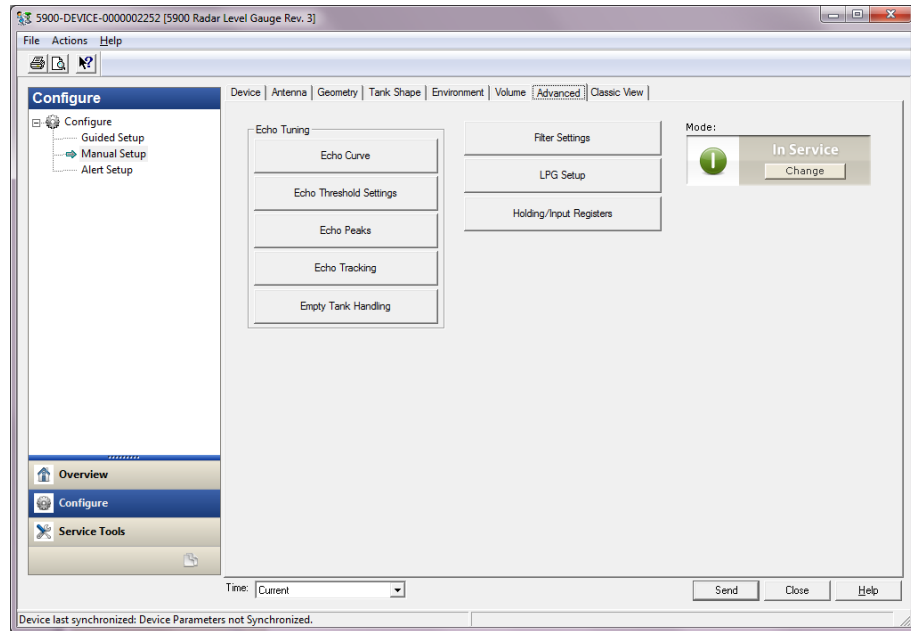

8. Click the **LPG Setup** button.
9. Select the **Vapor Pressure and Temperature** tab.

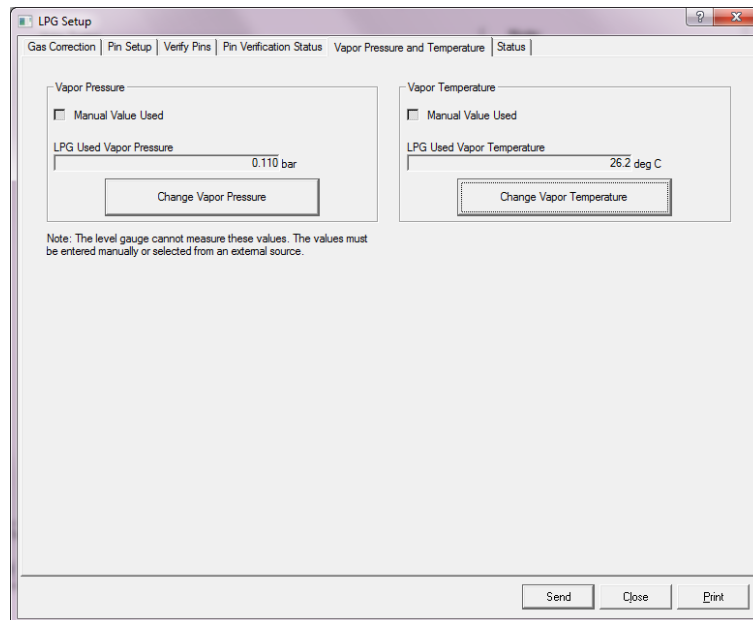

10. Verify that Vapor Pressure and Vapor Temperature appear in the corresponding fields. If not, check that the devices are properly wired and the Analog Output blocks are configured in, for example, Control Studio. In case you would like to use manual values, click the **Change Vapor Temperature/Change Vapor Pressure** button and follow the method's instructions.

11. Select the **Gas Correction** tab.

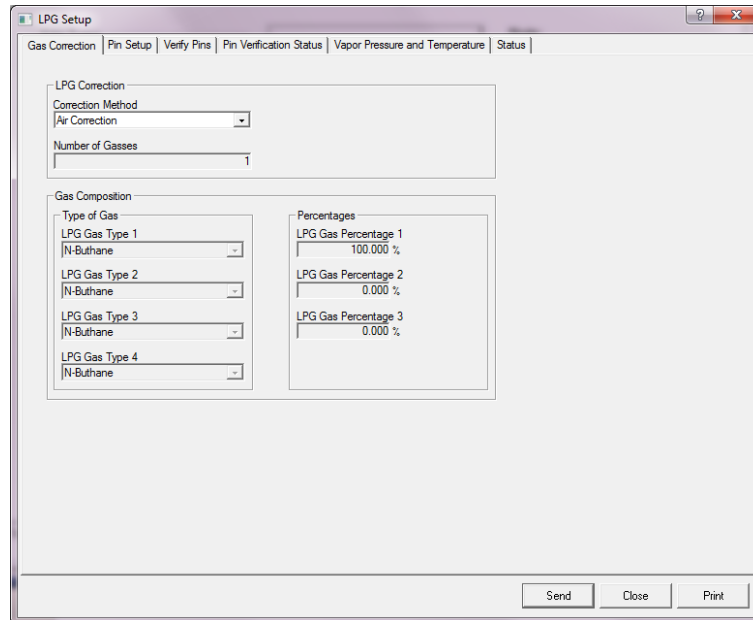

12. Choose correction method **Air Correction**. This setting is used during the Pin Verification procedure. When the LPG Setup is finished, and the tank is ready to be put into operation, the correction method must be set to correspond with the type of product in the tank.

FOUNDATION Fieldbus parameters:

TRANSDUCER 1500>LPG_CORRECTION_METHOD

13. Calibrate. Check the distance to the calibration ring at the end of the still-pipe as measured by the Rosemount 5900S Radar Level Gauge. Adjust the Calibration Distance in case the measured distance is not equal to the actual distance between the Tank Reference Point and the calibration ring. See [Tank geometry](#) for more information on tank geometry settings.

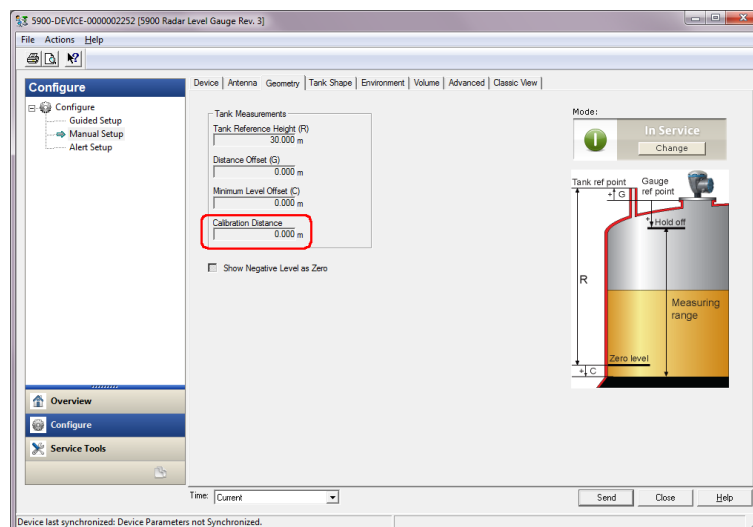

Note

It is important that the Inner Diameter of the still-pipe is properly configured. Open the **Antenna** tab in case you would like to verify the Inner Diameter configuration.

See [LPG/LNG antenna requirements](#) for more information on still-pipe requirements for the Rosemount 5900S with LPG/LNG Antenna.

FOUNDATION Fieldbus parameter:

TRANSDUCER 1100>CALIBRATION_DIST

14. Select the **Pin Setup** tab to configure the Verification Pin.

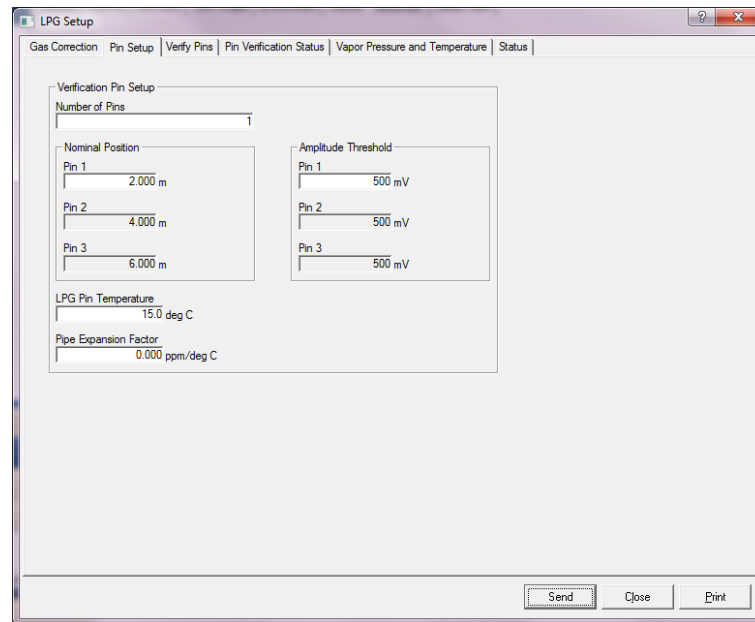

15. Enter nominal position. Normally, there is one verification pin placed at 2500 mm below the flange. In case there are two or three verification pins, enter nominal position for each one. In addition to that, a calibration ring should be installed at the bottom end of the still-pipe. It will be used for calibrating the tank geometry parameters. See [LPG/LNG antenna requirements](#) for more information.

The Pipe Expansion Factor lets you compensate for thermal expansion of the still-pipe.

FOUNDATION Fieldbus parameters:

TRANSDUCER 1500>LPG_NUMBER_OF_PINS

TRANSDUCER 1500>LPG_PIN1_CONFIGURATION

TRANSDUCER 1500>LPG_PIN2_CONFIGURATION

TRANSDUCER 1500>LPG_PIN3_CONFIGURATION

TRANSDUCER 1500>LPG_PIN_TEMPERATURE

TRANSDUCER 1500>LPG_PIN_TEMP_EXP_PPM

16. Verify pin position:
a) Open the **Verify Pins** tab.

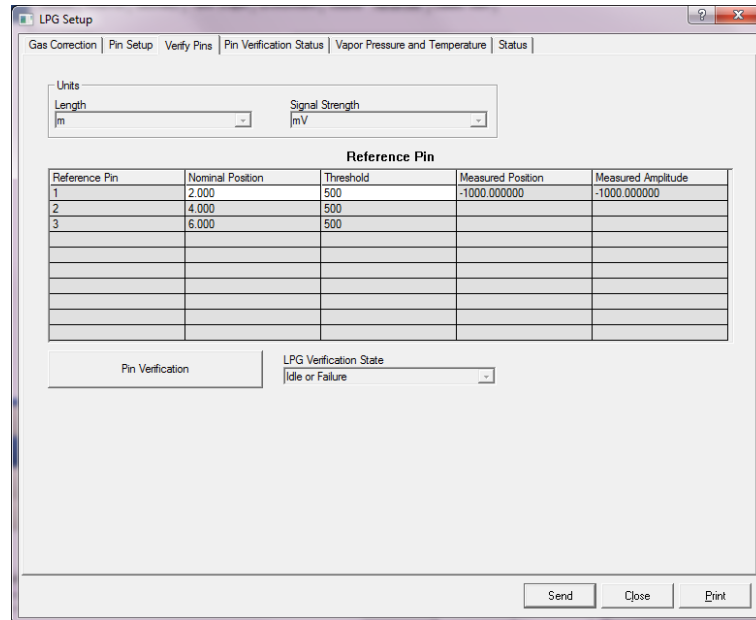

- b) Click the **Pin Verification** button to start the verification process.
- c) Compare **Measured Position** with **Nominal Position** (actual position of the Verification Pin in the Still-pipe).
- d) In case the Measured Position deviates from the Nominal Position, note the Measured Position and return to the **Pin Setup** tab.
- e) Enter the Measured position into the *Nominal Position* field and click the **Send** button.
- f) Repeat 16.a to 16.e. until the message `Successful Verification` appears, indicating that Nominal Position corresponds to the Measured Position.

FOUNDATION Fieldbus parameters:

TRANSDUCER 1500>LPG_VER_PIN1_

TRANSDUCER 1500>LPG_PIN1_CONFIGURATION

17. Select the **Gas Correction** tab.

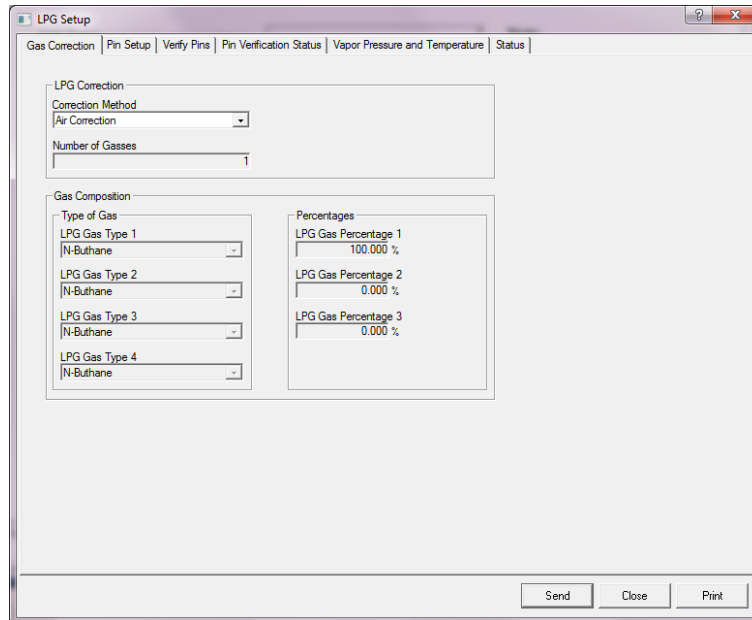

18. Choose the appropriate correction method for the product in the tank:

Option	Description
Air Correction	This method should only be used when there is no vapor in the tank, i.e. when the tank is empty and contains air only. It is used in the initial step when calibrating the Rosemount 5900S.
One known gas	This method may be used when there is only one gas type in the tank. It provides the highest accuracy among the different correction methods. Note that even small amounts of another gas reduces the accuracy.
One or more unknown gases	Use this method for hydrocarbons, for example Propane/ Butane, when the exact mixture is not known.
Two gases with unknown mixratio	This method is suitable for a mixture of two gases even if the mixratio is not known.
One or more known gases with known mixratio	This method may be used when there is a well known mixture of up to 4 products in the tank.

Now the Rosemount 5900S level gauge is ready to measure the product level when the tank is put into operation.

FOUNDATION Fieldbus parameters:

TRANSDUCER 1500>LPG_CORRECTION_METHOD

TRANSDUCER 1500>LPG_NUMBER_OF_GASSES

TRANSDUCER 1500>LPG_GAS_TYPE1, TRANSDUCER 1500>LPG_GAS_PERC1

TRANSDUCER 1500>LPG_GAS_TYPE2, TRANSDUCER 1500>LPG_GAS_PERC2
TRANSDUCER 1500>LPG_GAS_TYPE3, TRANSDUCER 1500>LPG_GAS_PERC3
TRANSDUCER 1500>LPG_GAS_TYPE4

5 Operation

5.1 Safety messages

Instructions and procedures in this section may require special precautions to ensure the safety of the personnel performing the operations. Information that potentially raises safety issues is indicated by a warning symbol () . Refer to the following safety messages before performing an operation preceded by this symbol.

WARNING

Failure to follow safe installation and servicing guidelines could result in death or serious injury.

- Ensure only qualified personnel perform the installation.
- Use the equipment only as specified in this manual. Failure to do so may impair the protection provided by the equipment.
- Do not perform any service other than those contained in this manual unless you are qualified.

Explosions could result in death or serious injury.

- Verify that the operating atmosphere of the transmitter is consistent with the appropriate hazardous locations certifications.
 - Before connecting a handheld communicator in an explosive atmosphere, ensure that the instruments in the loop are installed in accordance with intrinsically safe or non-incendive field wiring practices.
 - Do not remove the gauge cover in explosive atmospheres when the circuit is alive.
-

5.2 Viewing measurement data in Rosemount TankMaster

The Rosemount™ TankMaster program has several options for viewing measurement and inventory data for single tanks and tank groups. TankMaster also offers the option to create custom views with your own set of parameters. See the Rosemount TankMaster WinOpi [Reference Manual](#) for more information.

Figure 5-1: Example of a Bargraph View in Rosemount TankMaster WinOpi

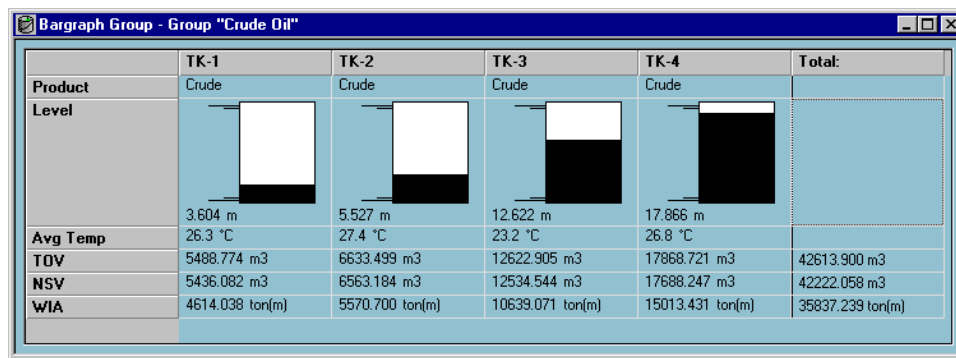

5.3 Alarm handling

The Rosemount™ TankMaster WinOpi program supports a wide range of alarm functions. Alarms can be set for various measurement data such as Level, Average Temperature, and Vapor Pressure. Alarm limits can also be specified for inventory data such as Net Standard Volume (NSV).

Active alarms can be shown in the *Alarm Summary* window. The Alarm Log lets you view alarms that are no longer active. The Alarm Log can be saved to disk for future reference.

See the Rosemount TankMaster WinOpi [Reference Manual](#) for more information.

Alerts

For information on how to setup and view active Field Diagnostic alerts see [Field diagnostic alerts](#) and [Alerts](#).

5.4 Viewing measurement data in AMS Device Manager

To view measurement data such as Level, Volume, Level Rate, and Signal Strength in AMS Device Manager:

Procedure

1. Open the **View** → **Device Connection View**.
2. Double-click the FF network icon and expand the network node to view the devices.
3. Right-click or double-click the desired Rosemount 5900S gauge icon to open the list of menu options:

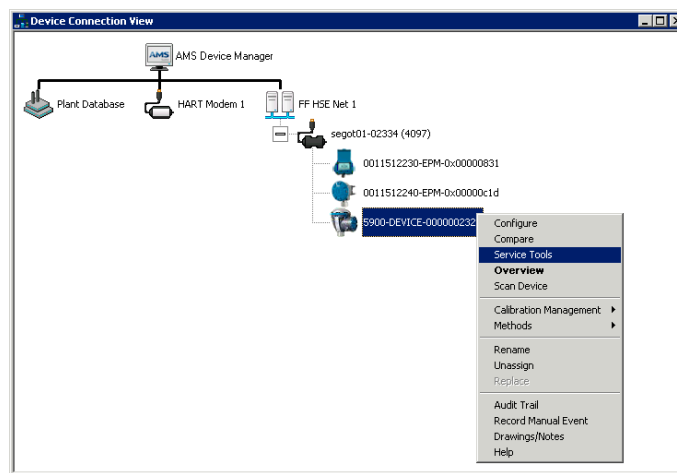

4. Choose the **Service Tools** option.

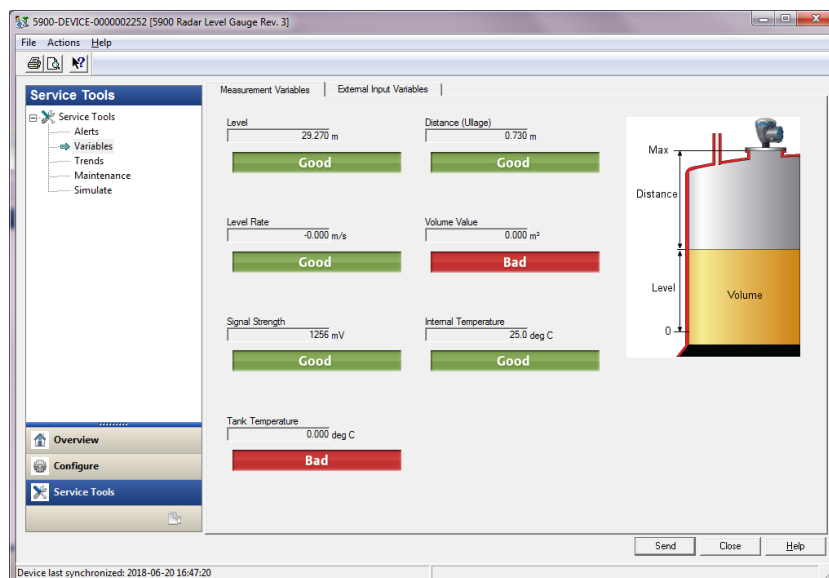

6 Service and troubleshooting

6.1 Safety messages

Instructions and procedures in this section may require special precautions to ensure the safety of the personnel performing the operations. Information that potentially raises safety issues is indicated by a warning symbol (⚠). Refer to the following safety messages before performing an operation preceded by this symbol.

⚠ WARNING

Failure to follow safe installation and servicing guidelines could result in death or serious injury.

- Ensure only qualified personnel perform the installation.
- Use the equipment only as specified in this manual. Failure to do so may impair the protection provided by the equipment.
- Do not perform any service other than those contained in this manual unless you are qualified.
- To prevent ignition of flammable or combustible atmospheres, disconnect power before servicing.
- Substitution of components may impair Intrinsic Safety.

Explosions could result in death or serious injury.

- Verify that the operating atmosphere of the transmitter is consistent with the appropriate hazardous locations certifications.
 - Before connecting a handheld communicator in an explosive atmosphere, ensure that the instruments in the loop are installed in accordance with intrinsically safe or non-incendive field wiring practices.
 - Do not remove the gauge cover in explosive atmospheres when the circuit is alive.
-

6.2 Service

This section briefly describes functions which may be useful for service and maintenance of a Rosemount 5900S Radar Level Gauge. If not otherwise stated, most examples are based on using the Rosemount TankMaster WinSetup tool to access these functions. See the Rosemount Tank Gauging [System Configuration Manual](#) for more information on how to use the WinSetup program.

6.2.1 Viewing input and holding registers using TankMaster™

In a Rosemount Tank Gauging system, measurement data is continuously stored in Input Registers of devices such as the Rosemount 2410 Tank Hub, Rosemount 5900 Radar Level Gauge, and other devices. By viewing the input registers of a device, you can verify that the device is working properly.

Holding Registers store various device parameters used to control measurement performance.

Procedure

1. Start the TankMaster WinSetup program.
2. In the **TankMaster WinSetup** workspace window, select the device icon.

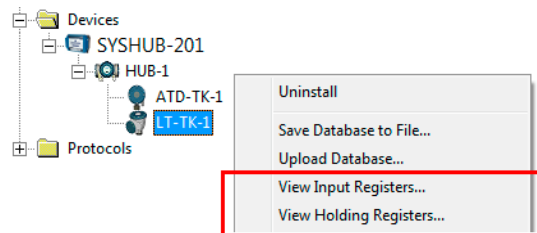

3. Right-click and select **View Input/View Holding Registers** option, or from the **Service** menu choose **Devices** → **View Input/View Holding Registers**.

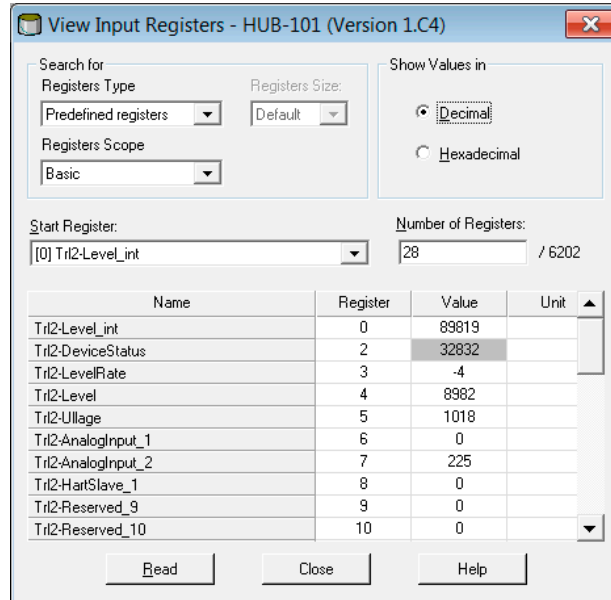

- In the **Registers Type** list, select **Predefined** or **All**.

Option	Description
Predefined	View a basic selection of registers.
All	View a range of registers by your own choice (for advanced service).

- For the **All** option, you have to specify a range of registers by setting a start value in the **Start Register input** field, and the total number of registers to be displayed in the **Number of Registers** field (1-500). Up to 50 registers is recommended for a quick update of the list.
- The **Registers Scope** drop-down list has three options:

Scope	Description	Access level
Basic	Standard setting that includes the most commonly used registers	View Only
Service	Includes a wider range of registers for advanced service and troubleshooting	Supervisor
Developer	For advanced users only	Administrator

- In the **Show Values in** pane, choose the appropriate register format **Decimal** or **Hexadecimal**.
- Click the **Read** button.
Now the **Value** column is updated with the current register values.

6.2.2 Backing up the level gauge configuration

Input and holding registers for the Rosemount 5900S Radar Level Gauge can be stored on disk. This can be useful for backup purposes and troubleshooting. You can save a predefined set of holding registers to make a backup copy of the current gauge configuration. The backup file can be used to restore the level gauge configuration.

Backing up a device configuration using TankMaster™

Using Rosemount TankMaster WinSetup to save the current device configuration to file:

Procedure

1. Start the Rosemount TankMaster WinSetup program.
2. In the **TankMaster WinSetup** workspace window, right-click the device icon.
3. Choose the **Save Database to File** option.

This option is also available from the **Service/Devices** menu.

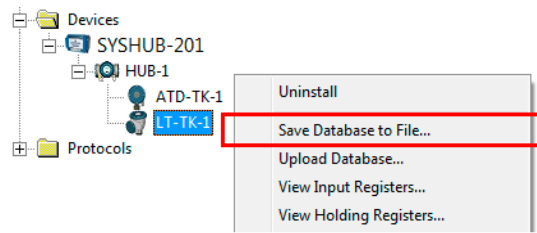

4. Choose the **Holding Registers** and **Predefined Registers** options (the User-Defined option should only be used for advanced service).

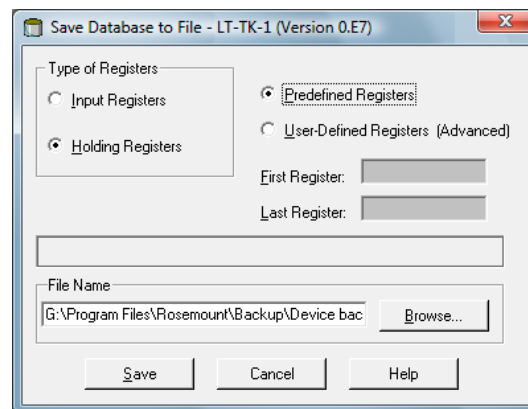

5. Click the **Browse** button, select a folder and type a name for the backup file.
6. Click the **Save** button to start saving the database registers.

Backing up multiple device configurations using TankMaster™

Using Rosemount TankMaster WinSetup to save configuration for multiple devices:

Procedure

1. Start the Rosemount TankMaster WinSetup program.
2. In the *WinSetup* workspace window select the **Devices** folder.
3. Click the right mouse button and choose the **Save Database of All to Files** option.

This option is also available from the **Service/Devices** menu.

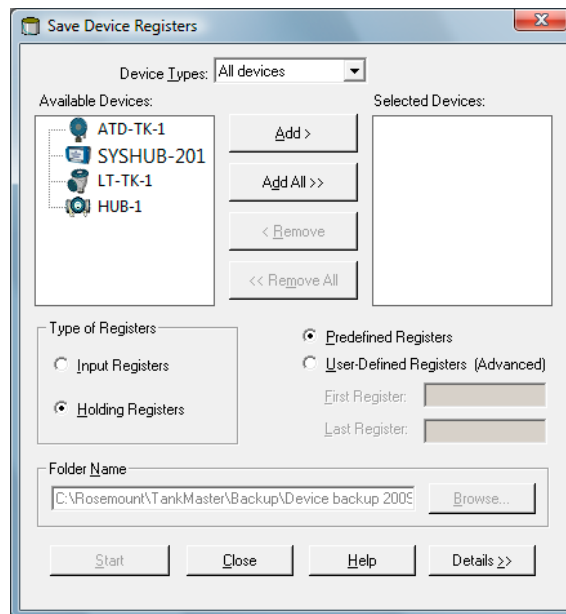

4. Select a device from the *Available Devices* pane and press the **Add** button in order to move it to the *Selected Devices* pane. Repeat for all devices you wish to include.
5. Choose the **Holding Registers** and **Predefined Registers** options (the User-Defined option should only be used for advanced service).
6. Click the **Browse** button, select a folder and type a name for the backup file.
7. Click the **Start** button to save the database backup.

The backup file can be viewed as a text file in any word processing program:

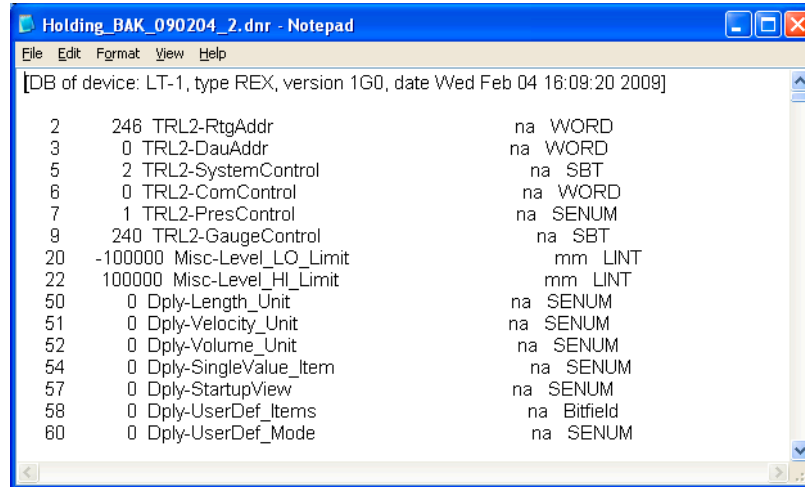

6.2.3 Recover a backup configuration database using TankMaster™

Rosemount TankMaster WinSetup lets you replace the current Holding Register database with a backup database stored on disk. This can be useful, for example, if you want to recover lost configuration data.

To load a Holding Register database do the following:

Procedure

1. In the **TankMaster WinSetup** workspace window, select the device icon.
2. Right-click and select **Upload Database**, or from the **Service** menu choose **Devices/Upload Database**.

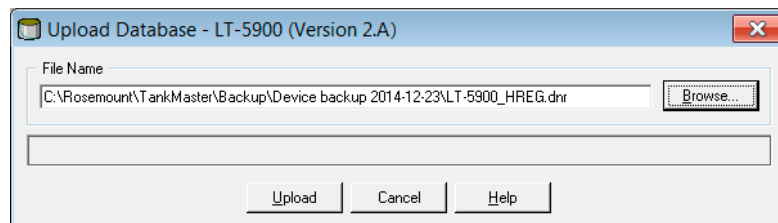

3. Click the **Browse** button and choose a database file to be uploaded, or type a path and file name.
4. Click the **Upload** button.

6.2.4 View and configure diagnostic registers using TankMaster™

The Rosemount TankMaster WinSetup program lets you view the current device status. The **View Diagnostic Register** window shows a selection of database registers that gives

you an instant view of how the gauge operates. You may also configure the window by adding registers of special interest.

Procedure

1. In the **TankMaster WinSetup** workspace window, right-click the device icon.

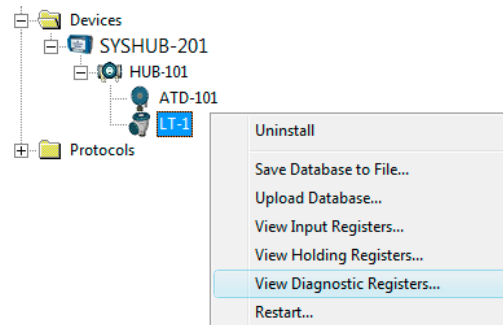

2. Right-click and select **View Diagnostic Registers**.

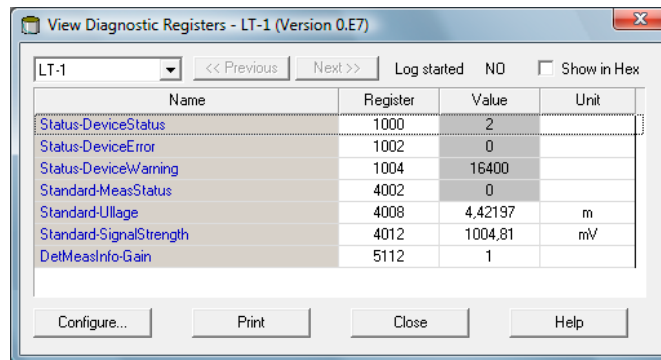

Diagnostics registers window

The register values in the diagnostics window are of read only type. They are loaded from the device as the window is opened.

A grey background color of the table cell in the Value column means that the register is of either Bitfield or ENUM type. An expanded Bitfield/ENUM window can be opened for this type of register. Double-click the cell to open the Expanded Bitfield/ENUM window.

If needed, the values can be presented as hexadecimal numbers. This applies to all registers of Bitfield and ENUM types. Select the **Show in Hex** check box to present Bitfield and ENUM registers as hexadecimal numbers.

The **Configure** button lets you open the *Configure Diagnostic Registers* window where you can change the list of registers to be displayed in the *View Diagnostic Registers* window. See the Rosemount Tank Gauging [System Configuration Manual](#) for more information.

The **Configure Diagnostic Registers** window also has a **Log Setup** button for access to the **Register Log Scheduling** window which allows you to setup a log schedule for automatic start and stop of register logging. See [Logging measurement data using TankMaster™](#) for more information.

6.2.5 Upgrading the device firmware using TankMaster™

Rosemount TankMaster WinSetup includes the option to upgrade the Rosemount 5900S and other devices in a Rosemount Tank Gauging system with new firmware.

Prerequisites

Note

The Rosemount 5900S must not be in SIL Safety mode when it is reprogrammed. Ensure that necessary safety precautions are considered.

Procedure

1. Ensure that the Rosemount 5900S communicates with TankMaster without any interruptions or disturbances.
2. In the **Rosemount TankMaster WinSetup** workspace window (Logical View), open the **Devices** folder and select the device to be upgraded (or select the **Devices** folder to allow multiple devices programming).
3. Right-click and select the **Program** option (**Program All** option for multiple devices programming). The device will automatically appear in the **Program These Devices** pane.

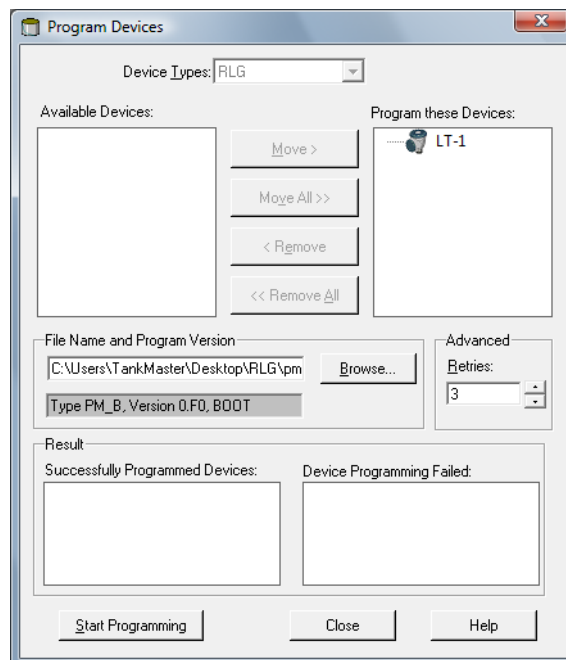

4. In case the **Devices** folder in the WinSetup workspace was selected for multiple programming, choose the desired device to be programmed from the **Available Devices** pane and click the **Move** button.

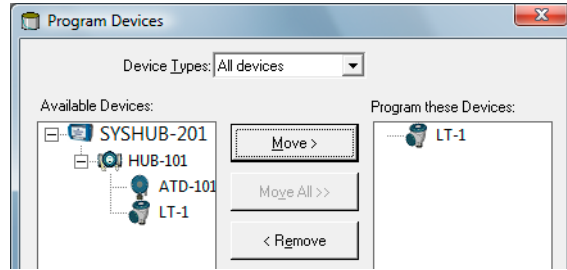

5. Repeat for each device to be programmed. Use the **Remove** button if you wish to change the list of devices to be programmed.
6. Click the **Browse** button to locate the flash program file. File extension *.cry is used for these files.
7. Click the **Start Programming** button.

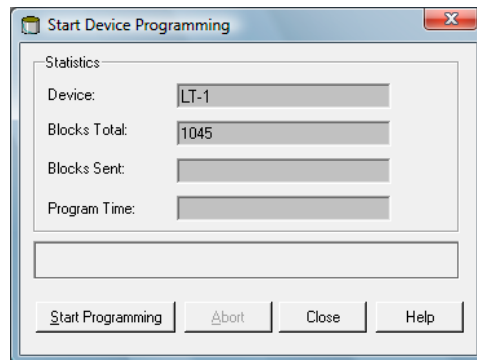

Now the **Start Device Programming** window appears.

8. Click the **Start Programming** button to activate device programming.
If a Rosemount 2460 System Hub is used, a maximum of 25 devices can be programmed. If there are more devices the programming must be divided in two steps.
9. Update the TankMaster installation by adding new *.ini files for the Rosemount 5900S gauge to the TankMaster installation folder:
Two *.ini files are used for the Rosemount 5900S, RLG.ini and RLG0xx.ini, where xx is the identification code of the application software.
 - a) Copy the RLG.ini file to the C:\Program Files\Rosemount\Server folder.
 - b) Copy the RLG0xx.ini file to the C:\Program Files\Rosemount\Shared folder.

6.2.6 Write protection using TankMaster™

A Rosemount 5900S can be software write protected to avoid unintentional configuration changes. Software write protection locks the holding register database.

Procedure

1. Start the Rosemount TankMaster WinSetup program.
2. In the **TankMaster WinSetup** workspace, select the **Logical View** tab.
3. Right-click the device icon.

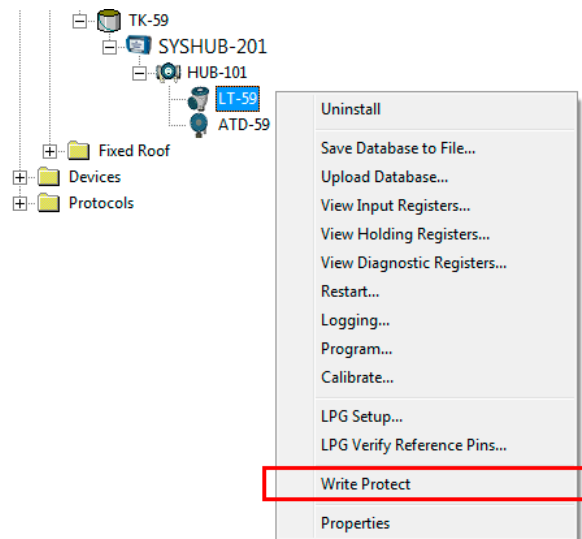

4. Select **Write Protect**.



5. In the **New State** drop-down list, select **Protected**, and then click the **Apply** button to save the new write protect state.
Now the holding register database is locked. As long as the device is write protected no configuration changes can be made.
6. Click the **OK** button to close the **Write Protect** window.

Unlock the device

To unlock the device:

Procedure

1. Choose the **Write Protect** option to open the *Write Protect* window.
2. Set **New State** to **Not Protected**.
3. Press the **Apply** button to save the new state and the **OK** button to close the window.

Write protection using AMS Device Manager

To lock the device:

Procedure

1. In AMS Device Manager the Write Protection function is available in the **Device** tab under **Configure Manual Setup**.

A check box indicates whether the device is write protected or not.

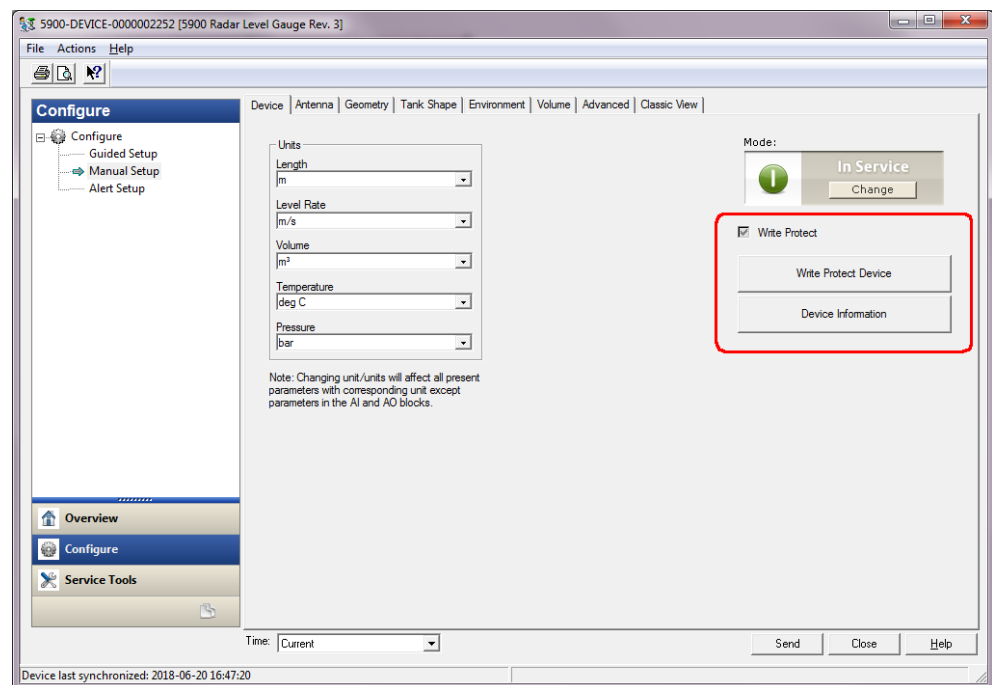

2. Click the **Write Protect Device** button.
3. Enter a password.

6.2.7 Write protection switch

A switch can be used to prevent unauthorized changes in the Rosemount 5900S database. The switch also prevents modification of FOUNDATION™ Fieldbus parameters.

To write protect the gauge do the following:

Procedure

1. Check if there is any sealed screw. Contact Emerson Automation Solutions/ Rosemount Tank Gauging before breaking the seal if warranty is still valid. Completely remove the seal so that it does not damage the threads.

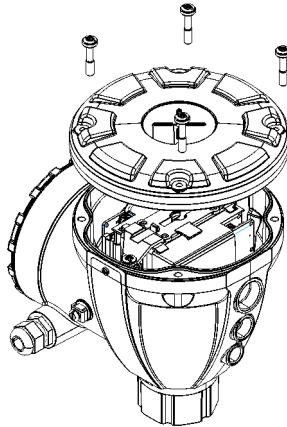

2. Loosen the screws and remove the cover.

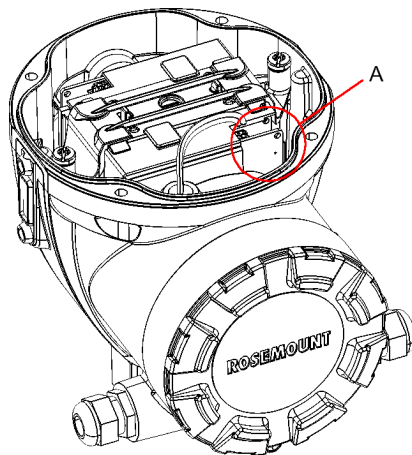

A. Write protection switch

3. Locate the write protection switch. It is the second switch (2) marked P.

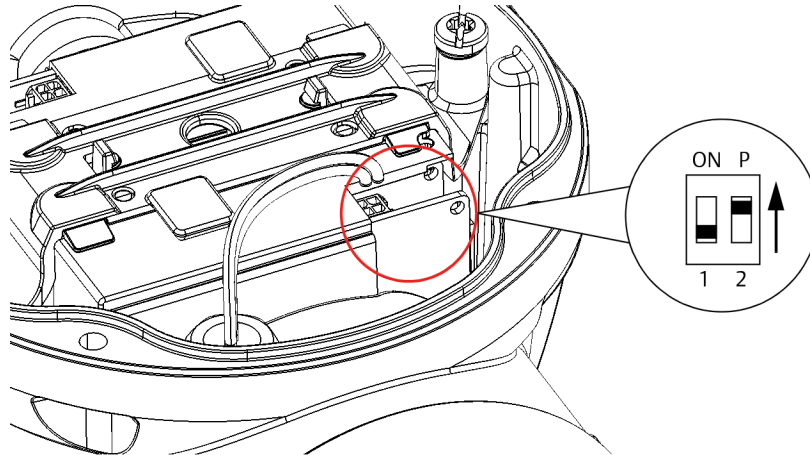

4. To write protect the level gauge, move switch P to the upper position.
5. Check that contact surfaces on the housing and cover are clean. Replace the cover and tighten the screws. Make sure that the cover is fully engaged to meet explosion-proof requirements and to prevent water from entering the terminal compartment.

Note

Ensure that O-rings and seats are in good condition prior to mounting the cover in order to maintain the specified level of ingress protection.

6.2.8 Logging measurement data using TankMaster™

The Rosemount 5900S supports logging of diagnostic registers. This function is useful for verifying that the gauge works properly. The logging function can be accessed by using the Rosemount TankMaster WinSetup program.

Procedure

1. Start the Rosemount TankMaster WinSetup program.
2. In the **TankMaster WinSetup** workspace window, select the device icon.

3. Right-click and select **Logging**.

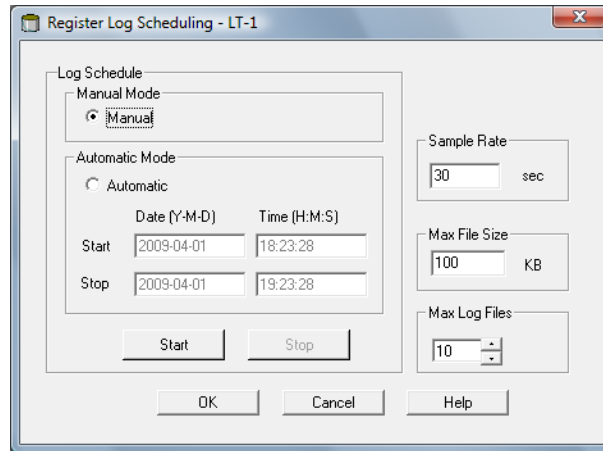

4. Select **Manual** or **Automatic** mode.

Option	Description
Manual	Manual mode lets you start logging at any time. Logging will proceed until it is stopped by clicking the Stop button.
Automatic	In Automatic mode you have to specify a Start and Stop time. Logging will proceed until the stop date and time is reached.

The resulting log file will not exceed the size specified by the Max File Size parameter. When the number of log files has reached the Max Log Files value, TankMaster starts replacing the contents of existing log files.

Log files

Log files are stored in plain text file format and can be viewed in any word processing program. They are stored in the following folder: C:\Rosemount\TankMaster\Log, where C is the disk drive where the Rosemount TankMaster software is installed. A log file contains the same input registers as the **View Diagnostic Registers** window, see [View and configure diagnostic registers using TankMaster™](#). You can change which input registers to be included in the log file by configuring the **View Diagnostic Registers** window, see the Rosemount Tank Gauging [System Configuration Manual](#) for more information.

Figure 6-1: Log File

SEGO701-01729_LT-1_3.log - Notepad

File Edit Format View Help

 Device Name: LT-1
 Device: 5900
 Started logging: 2009-02-05 16:54:48

Date	Time	IR1002	IR1004	IR1000	IR4002	IR4012	IR5112	IR1420	IR0	IR4	IR54	IR4006	IR2
2009-02-05	16:54:58	0	0	0	65536	2382,43	8	1	96521	9652	9652	9,85209	
2009-02-05	16:55:08	0	0	0	65536	2382,7	8	1	96521	9652	9652	9,8521	
2009-02-05	16:55:18	0	0	0	65536	2385,7	8	1	96521	9652	9652	9,85215	
2009-02-05	16:55:28	0	0	0	65536	2382,06	8	1	96522	9652	9652	9,85213	
2009-02-05	16:56:14	0	0	0	65536	2383,5	8	1	96522	9652	9652	9,8522	
2009-02-05	16:56:24	0	0	0	65536	2388,86	8	1	96522	9652	9652	9,85217	
2009-02-05	17:03:29	0	0	0	65536	2380,95	8	1	96521	9652	9652	9,85204	
2009-02-05	17:07:08	0	0	0	65536	2382,85	8	1	96521	9652	9652	9,85205	
2009-02-05	17:07:18	0	0	0	65536	2382,93	8	1	96521	9652	9652	9,85207	
2009-02-05	17:07:28	0	0	0	65536	2382,92	8	1	96521	9652	9652	9,85207	

6.2.9 Loading the default database using TankMaster™

The Default Database is the original factory settings of the holding register database. Rosemount TankMaster WinSetup offers the option to load the Default Database. This can be useful if, for example, you want to try new database settings and then want to reload the original factory settings, or when tank conditions have been altered.

Prerequisites

If error messages appear or other problems occur concerning the Database a troubleshooting is recommended before loading the Default Database.

Note

The device address remains unaltered when the default database is loaded.

Procedure

1. In the **TankMaster WinSetup** workspace window, select the desired device icon.
2. Right-click and select **View Holding Register**.

3. Choose the **All** option and type **65510** in the **Start Register** input field.

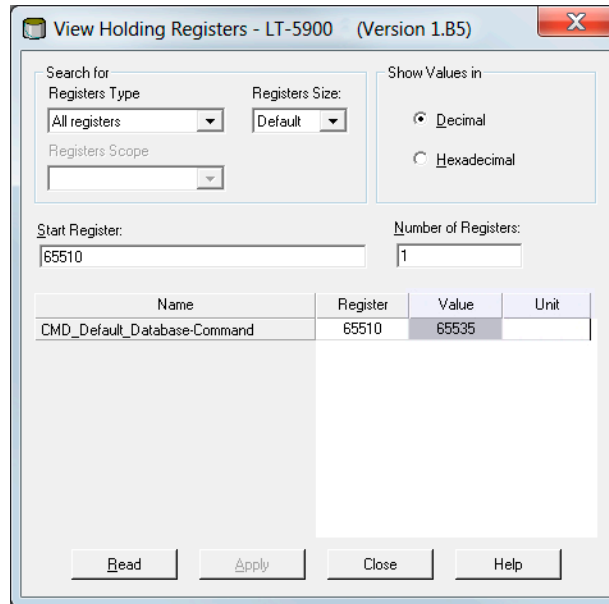

4. Type the desired number of registers to be displayed in the **Number of Registers** field and click the **Read** button.
5. Double-click in the **Value** (65535) field.

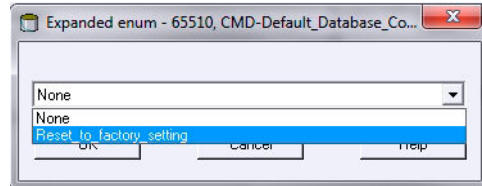

6. From the drop-down list, select the **Reset_to_factory_setting** option.
7. Click the **OK** button.

6.3 Troubleshooting

This section describes various problems that may occur due to malfunctioning devices or incorrect installations. Note that symptoms and actions related to the Rosemount 2410 Tank Hub and Rosemount 2460 System Hub (2160 Field Communication Unit in legacy systems) are not applicable for FOUNDATION™ Fieldbus systems.

Table 6-1: Troubleshooting Chart for the Rosemount 5900S

Symptom	Possible cause	Action
No communication with the Rosemount 5900S Radar Level Gauge	Wiring	<ul style="list-style-type: none"> • Check that the device appears in the <i>Device Live List</i>, see the Rosemount 2410 Tank Hub Reference Manual for more information • Check that wires are properly connected to the terminals • Check for dirty or defective terminals • Check wire insulation for possible short circuits to ground • Check that there are no multiple shield grounding points • Check that the cable shield is grounded at the power supply end (Rosemount 2410 Tank Hub) only • Check that the cable shield is continuous throughout the Tankbus network • Check that the shield inside the instrument housing does not come into contact with the housing • Check that there is no water in conduits • Use shielded twisted pair wiring • Connect wiring with drip loops • Check the Rosemount 2410 Tank Hub wiring • See Electrical installation
	Incorrect Tankbus termination	<ul style="list-style-type: none"> • Check that there are two terminators on the Tankbus. Normally the built-in termination in the Rosemount 2410 Tank Hub is enabled. • Check that terminations are placed at both ends of the Tankbus
	Too many devices on the Tankbus	<ul style="list-style-type: none"> • Check that the total current consumption of the devices on the Tankbus is less than 250 mA. See the Rosemount 2410 Tank Hub Reference Manual for more information. • Remove one or more devices from the Tankbus. The Rosemount 2410 Tank Hub supports a single tank. The multiple tank version of the 2410 supports up to 10 tanks.

Table 6-1: Troubleshooting Chart for the Rosemount 5900S (continued)

Symptom	Possible cause	Action
	Cables are too long	<ul style="list-style-type: none"> Check that the input voltage on the device terminals is 9 V or more
	Hardware failure	<ul style="list-style-type: none"> Check the Rosemount 5900S Radar Level Gauge Check the Rosemount 2460 System Hub Check the Rosemount 2180 Field Bus Modem (FBM) Check the communication port on the control room PC Contact Emerson Automation Solutions /Rosemount Tank Gauging service department
	Software failure	<ul style="list-style-type: none"> Restart the Rosemount 5900S gauge. Use for example the Restart command in Rosemount TankMaster WinSetup Restart all devices by disconnecting and connecting the power supply to the Rosemount 2410 Tank Hub Contact Emerson Automation Solutions /Rosemount Tank Gauging service department
No communication with the Rosemount 5900S Radar Level Gauge	Rosemount 2180 Field Bus Modem (FBM)	<ul style="list-style-type: none"> Check that the FBM is connected to the right port on the control room PC Check that the FBM is connected to the right port on the Rosemount 2460 System Hub
	Connection to Rosemount 2460 System Hub	<ul style="list-style-type: none"> Check that the right field bus port on the Rosemount 2460 System Hub is connected to the Primary bus on the Rosemount 2410 Tank Hub Check communication port LED:s inside the Rosemount 2460
	Incorrect configuration of Rosemount 2460 System Hub	<ul style="list-style-type: none"> In the system hub's tank database, check the Modbus communication addresses of the Rosemount 5900S and the Rosemount 2410 Tank Hub Check configuration of communication parameters for the field ports Check that the correct communication channel is selected See the Rosemount Tank Gauging System Configuration Manual for more information on how to configure the Rosemount 2460 System Hub

Table 6-1: Troubleshooting Chart for the Rosemount 5900S (continued)

Symptom	Possible cause	Action
	Incorrect configuration of Rosemount 2410 Tank Hub	<ul style="list-style-type: none"> Check the Rosemount 2410 tank database; ensure that the device is available and mapped to the right tank In Rosemount TankMaster WinSetup open the <i>Rosemount 2410 Tank Hub /Tank Database</i> window and check that the Level Modbus address is equal to the 2410 Level Modbus address in the Rosemount 2460 System Hub's tank database See the Rosemount Tank Gauging System Configuration Manual for more information on how to configure the tank database of the Rosemount 2410.
	Connection to Rosemount 2410 Tank Hub	<ul style="list-style-type: none"> Check wiring to the Rosemount 2410 Tank Hub Check the Rosemount 2410 Tank Hub; check the Error LED or the integral display for information
	Configuration of communication protocol	In the Rosemount TankMaster WinSetup/Protocol Channel Properties window: <ul style="list-style-type: none"> Check that the protocol channel is enabled Check the protocol channel configuration (port, parameters, modem)
No level measurement	Communication failure	<ul style="list-style-type: none"> Check wiring Check the Modbus communication address for the Rosemount 5900S. See the Rosemount Tank Gauging System Configuration Manual for more information on how to setup the Modbus address of a Rosemount 5900S Radar Level Gauge. Check configuration of the Rosemount 2410 Tank Hub's tank database Check configuration of the Rosemount 2460 System Hub's tank database
	Configuration	<ul style="list-style-type: none"> Check that the Rosemount 5900S is configured (see the Rosemount Tank Gauging System Configuration Manual for more information)
	Incorrect configuration of the Rosemount 2460 System Hub's tank database	<ul style="list-style-type: none"> Check the Modbus communication address in the system hub's tank database. In Rosemount TankMaster WinSetup open the <i>Rosemount 2460/Tank Database</i> window and check that the 2410 Level Modbus address in the tank database is equal to the Level Modbus address in the 2410 tank database. See the Rosemount Tank Gauging System Configuration Manual for more information on how to configure the Rosemount 2460 System Hub's tank database.

Table 6-1: Troubleshooting Chart for the Rosemount 5900S (continued)

Symptom	Possible cause	Action
	Incorrect configuration of the Rosemount 2410 Tank Hub's tank database	<ul style="list-style-type: none"> Check the Rosemount 2410 tank database; ensure that the level gauge is available and mapped to the right tank In Rosemount TankMaster WinSetup open the <i>Rosemount 2410 Tank Hub /Tank Database</i> window and check that the Level Modbus address is equal to the 2410 Level Modbus address in the Rosemount 2460 System Hub's tank database See the Rosemount Tank Gauging System Configuration Manual for more information on how to configure the 2410 tank database
	Software or hardware failure	<ul style="list-style-type: none"> Check diagnostics information, see View and configure diagnostic registers using TankMaster™ Check Device Status input register, see Device status Contact Emerson Automation Solutions /Rosemount Tank Gauging service department
Incorrect level measurement	Incorrect configuration	<ul style="list-style-type: none"> Check configuration of tank geometry and antenna parameters: - Tank Reference Height (R) - Gauge Reference Distance (G) - Calibration distance - Antenna type - Antenna size (Still pipe Array) See the Rosemount Tank Gauging System Configuration Manual for more information on how to use Rosemount TankMaster WinSetup for configuration of tank geometry and antenna parameters. Verify that the mechanical installation of the Rosemount 5900S fulfills installation requirements. Check for example: - nozzle height and diameter - obstacles in the vicinity of the nozzle - distance to tank wall - inclination - total slot/hole area in still pipe See chapter Installation considerations. Check configuration of Environment parameters such as Foam, Turbulent Surface etc. and other advanced configuration options. WinSetup: Rosemount 5900S Properties/Environment, Rosemount 5900S Properties/Advanced Configuration. Check status and diagnostics information, see View and configure diagnostic registers using TankMaster™.

Table 6-1: Troubleshooting Chart for the Rosemount 5900S (continued)

Symptom	Possible cause	Action
	Disturbing objects in the tank	<ul style="list-style-type: none"> Check that the Rosemount 5900S has not locked on an interfering object in the tank Use the Tank Scan function in Rosemount TankMaster WinSetup to analyze the measurement signal: - Check if there are any disturbing echoes from obstacles in the tank - Check if there is a strong echo at the bottom of the tank; use deflection plate at the end of still pipe. See the Rosemount Tank Gauging System Configuration Manual for more information on how to use the Tank Scan function
The level gauge configuration can not be saved	The gauge is write protected	<ul style="list-style-type: none"> Check position of the write protection switch and make sure that it is in the OFF position, see Write protection switch. Check write protection setting in Rosemount TankMaster WinSetup, see Write protection using TankMaster™.

6.3.1 Device status

Table 6-2 shows device status messages that may appear on the display of the Rosemount 2410 Tank Hub, or in the Rosemount TankMaster program. Device status can be found in Input register 4000. See [Viewing input and holding registers using TankMaster™](#) for more information on how to view Input registers.

Table 6-2: Device Status Messages

Message	Description	Action
Running Boot Software	<ul style="list-style-type: none"> The application software could not be started. The application SW is not loaded in the flash memory The previous upload of the flash SW failed 	<p>Reprogram the gauge with new software.</p> <p>Contact Emerson Automation Solutions /Rosemount Tank Gauging service department.</p>
Device Warning	A device warning is active.	See Warning messages for details.
Device Error	A device error is active.	See Error messages for details.
BOOT Beta Version	Beta version of boot program used	Ensure that approved software is used
APPL Beta Version	Beta version of application program used	Ensure that approved software is used
Level correction error	The LPG module is enabled but the module is either incorrectly configured, or there is no sensor input data for pressure or temperature.	See Input register 4702 LPGIregArea-LPG_Corr_Error for more information.

Table 6-2: Device Status Messages (continued)

Message	Description	Action
Invalid Measurement	The level gauge indicates that measurement is invalid. This may be caused by an actual measurement problem or some other error indication.	Check Error Messages, Warning Messages and Measurement Status for details.
Write Protected	The configuration registers are write protected.	Do one of the following: 1. Use the Lock/Unlock function to turn off the software write protection. 2. Change position of the Write Protection switch to OFF.
Default Database	All configuration registers are set to default values.	Ensure that device calibration is valid.
Simulation Active	The Rosemount 5900S is in simulation mode.	Reset Rosemount 5900S simulation mode.
SIL Mode Enabled	The level gauge operates in SIL mode.	Ensure that the gauge is properly configured for SIL application.
FF Out of Service	The level gauge is set to Out of Service mode in order to allow service or configuration.	Ensure that mode is changed back to In Service when the gauge is back in operation.
RM Reprogramming In Progress	New software is downloaded to the Rosemount 5900S	Verify Rosemount 5900S operation when reprogramming is finished.

6.3.2 Warning messages

Table 6-3 shows a list of Warning messages that may appear on the integral display of the Rosemount 2410 Tank Hub and in the Rosemount TankMaster program. You also have the option to view Input register 1004 for an overview of active device warnings. Warnings are less serious than errors.

For each warning message that may appear, detailed information can be found in Input registers 6100 to 6130 as shown in Table 6-3.

Table 6-3: Warning Messages

Message	Description	Action
RAM warning	Input register no. 6100. Bit 0: DSP Stack Bit 1: DSP RAM low	Contact Emerson Automation Solutions /Rosemount Tank Gauging service department.
FEPROM warning	Input register no. 6102.	
HREG warning	Input register no. 6104. Bit 0: DSP Factory holding registers	Load default database and restart the Rosemount 5900S. Contact Emerson Automation Solutions/Rosemount Tank Gauging service department if the problem persists.

Table 6-3: Warning Messages (continued)

Message	Description	Action
Other memory warning	Input register no. 6106.	Contact Emerson Automation Solutions /Rosemount Tank Gauging service department
MWM warning	Input register no. 6108. Bit 1: Version mismatch between PM and RM	
RM warning	Input register no. 6110 Bit 1: SW config Bit 5: FPROM Checksum Bit 6: FPROM Version Bit 9: HREG Checksum Bit 10: HREG Limit Bit 11: HREG Write Bit 12: HREG Read Bit 13: HREG Version Bit 14: MWM Invalid Id Bit 30: SW Serious Warning	
Other hardware warning	Input register no. 6122.	
Configuration warning	Input register no. 6128. Bit 0: Super Test Active Bit 1: ATP Table Invalid Bit 2: Special Correction Table Invalid Bit 3: Near Zone Correction Table Invalid Bit 4: Config Model Code invalid Bit 5: Config LPG Pins Visible Bit 6: Config LPG Error Bit 7: Simulation Mode Used Bit 8: Default Sweep Mode Used Bit 9: Test Sweep used Bit 10: ACT Table Invalid Bit 11: UCT Table Invalid Bit 12: Simple Simulation Mode Warning Bit 13: Ramp Simulation Mode Warning Bit 14: TSM Filter Too Narrow Bit 15: MMS Offset Update disabled	<ul style="list-style-type: none"> • Load the default database and restart the level gauge, see Loading the default database using TankMaster™. • Configure the level gauge or load a backup configuration file (see Recover a backup configuration database using TankMaster™). • Contact Emerson Automation Solutions/Rosemount Tank Gauging service department if the problem persists.
SW warning	Input register no. 6130. Bit 8: DSP Undefined software warning	Contact Emerson Automation Solutions/Rosemount Tank Gauging service department

6.3.3 Error messages

Table 6-4 shows a list of error messages that may appear on the integral display of the Rosemount 2410 Tank Hub and in the Rosemount TankMaster program. You also have the option to view Input register 1002 for an overview of active device errors.

For each error message that may appear, detailed information can be found in Input registers 6000 to 6030 as shown in Table 6-4.

Table 6-4: Error Messages for the Rosemount 5900S

Message	Description	Action
RAM error	<p>Input register no. 6000.</p> <p>A gauge data memory (RAM) error has been detected during the startup tests.</p> <hr/> <p>Note This automatically resets the gauge.</p> <hr/> <p>Serious RAM problem: Bit 0: DSP RAM Bit 1: DSP stack Bit 2: DSP RAM checksum Bit 3: DSP RAM low</p>	Contact Emerson Automation Solutions /Rosemount Tank Gauging service department
FEPROM error	<p>Input register no. 6002.</p> <p>An error in the gauge program memory (FEPROM) has been detected during the startup tests.</p> <hr/> <p>Note This automatically resets the gauge.</p> <hr/> <p>Serious FEPROM problem: Bit 0: DSP Boot checksum Bit 1: DSP Boot version Bit 2: DSP Application checksum Bit 3: DSP Application version Bit 4: FEPROM device Bit 5: FEPROM erase Bit 6: FEPROM write Bit 7: FEPROM active block not used</p>	

Table 6-4: Error Messages for the Rosemount 5900S (continued)

Message	Description	Action
Database (Hreg) error	<p>Input register no. 6004.</p> <p>An error in the transmitter configuration memory (EEPROM) has been detected. The error is either a checksum error that can be solved by loading the default database or a hardware error.</p> <hr/> <p>Note The default values are used until the problem is solved.</p> <hr/> <p>The following bits indicate a serious Holding register problem: Bit 0: DSP checksum Bit 1: DSP limit Bit 2: DSP version Bit 3: Write error</p>	Load default database and restart the Rosemount 5900S Radar Level Gauge. Contact Emerson Automation Solutions /Rosemount Tank Gauging service department if the problem persists.
Other Memory error	Input register no. 6006.	Contact Emerson Automation Solutions /Rosemount Tank Gauging service department.
Microwave Module error	Input register no. 6008. Bit 0: Not connected	
RM error	Input register no. 6010 Bit 1: SW configuration Bit 5: FEPROM Checksum Bit 6: FEPROM Version Bit 9: HREG Checksum Bit 10: HREG Limit Bit 11: HREG Write Bit 12: HREG Read Bit 13: HREG Version Bit 14: MWM Invalid Id Bit 30: SW Serious Error	
Other hardware error	Input register no. 6022. An unspecified hardware error has been detected. Bit 0: Internal Temp Out of Range	

Table 6-4: Error Messages for the Rosemount 5900S (continued)

Message	Description	Action
Configuration error	<p>Input register no. 6028. At least one configuration parameter is outside allowed range.</p> <hr/> <p>Note The default values are used until the problem is solved.</p> <hr/> <p>Bit 0: Start Code Bit 1: FF Unit Conversion</p>	<ul style="list-style-type: none"> • Load the default database and restart the level gauge, see Loading the default database using TankMaster™. • Configure the level gauge or load a backup configuration file (see Recover a backup configuration database using TankMaster™). • Contact Rosemount Tank Gauging service department if the problem persists.
Software error	<p>Input register no. 6030. An error has been detected in the Rosemount 5900S gauge software.</p> <p>Bit 0: DSP Undefined SW Error Bit 1: DSP Task Not Running Bit 3: Simulated error</p>	Contact Emerson Automation Solutions /Rosemount Tank Gauging service department

6.3.4 Measurement status

Measurement Status information can be found by viewing Input register 4002. [Table 6-5](#) presents the various status bits that may appear.

Table 6-5: Measurement Status for the Rosemount 5900S

Message	Description	Action
Full tank	The level measurement is in Full Tank state. The transmitter waits for the surface echo to be detected at the top of the tank.	The transmitter leaves the Full Tank state when the product surface gets below the Full Tank Detection Area.
Empty tank	The level measurement is in Empty Tank state. The transmitter waits for the surface echo to be detected at the bottom of the tank.	The transmitter leaves the Empty Tank state when the product surface gets above the Empty Tank Detection Area. See Empty tank handling .
Dirty antenna	The antenna is so contaminated that the level measurement might be affected.	Clean the antenna.
Sweep linearization warning	The sweep is not correctly linearized.	Check Warning messages. If MWM Warning is active this might indicate a transmitter error. Contact Emerson Automation Solutions/ Rosemount Tank Gauging service department.
Tank signal clip warning	The last Tank Signal was clipped.	Check Warning Messages. If MWM Warning is active this might indicate a transmitter error. Contact Emerson Automation Solutions/ Rosemount Tank Gauging service department.
No surface echo	The Surface Echo Pulse can not be detected.	Check if the configuration can be changed so that the surface echo can be tracked in this current region.

Table 6-5: Measurement Status for the Rosemount 5900S (continued)

Message	Description	Action
Predicted level	The presented level is predicted. The surface echo could not be detected.	See No surface echo above.
Sampling failed	The sampling of the last tank signal failed.	Check Warning Messages.
Invalid volume value	The given volume value is invalid.	Check Volume Status for details.
Simulation Mode	The simulation mode is active. The presented measurement values are simulated.	No action needed.
Advanced Simulation Mode	The advanced simulation mode is active. The given measurements are simulated.	To turn off the Advanced Simulation mode set Holding Register 3600=0 (see Viewing input and holding registers using TankMaster™).
Tracking Extra Echo	The transmitter is in the empty tank state tracking an extra echo.	Verify that the level gauge tracks the product surface when the tank is filled.
Bottom Projection Active	The bottom projection function is active.	Verify that the level gauge properly tracks the product surface.
Pipe Measurement Enabled	Pipe Measurement is active.	No action needed.
Surface close to registered false echo	Close to a registered false echo measurement accuracy may be slightly reduced.	By using the Register False Echo function the transmitter can track the product surface in the vicinity of disturbing objects.
Sudden level jump detected	This may result from various measurement problems.	Check interior of the tank to find out what causes the problem tracking the surface.

6.4 Resource block

Error conditions found in the Resource block.

Table 6-6: Resource Block BLOCK_ERR Messages

Condition Name	Description
Block configuration error	Configuration Error is used to indicate that you have selected an item in FEATURES_SEL or CYCLE_SEL that was not set in FEATURES or CYCLE_TYPE, respectively
Simulate active	This indicates that the simulation switch is in place. This is not an indication that the I/O blocks are using simulated data
Power up	
Out of Service	The actual mode is out of service

Table 6-7: Resource Block DETAILED_STATUS Messages

Condition Name	Recommended action
Sensor Transducer block error	<ol style="list-style-type: none"> 1. Restart processor 2. Call service center
Manufacturing block error	<ol style="list-style-type: none"> 1. Restart processor 2. Call service center
Non-volatile memory error	<ol style="list-style-type: none"> 1. Restart processor 2. Call service center
ROM integrity error	<ol style="list-style-type: none"> 1. Restart processor 2. Call service center

6.5 Transducer block

Error conditions found in the transducer block.

Table 6-8: Transducer Block BLOCK_ERR Messages

Condition Name	Description
Other error	Set whenever XD_ERROR is non-zero. See also Viewing device status in AMS Device Manager .
Out of Service	The actual mode is out of service.

6.6 Analog Input (AI) function block

Table 6-9 lists conditions reported in the BLOCK_ERR parameter. Conditions in bold type are available for the Analog Input block. Conditions in *italics* are inactive for the AI block and are given here only for your reference.

A block alarm will be generated whenever the BLOCK_ERR has an error bit set. Block error types for the AI block are defined below in bold type.

Table 6-9: BLOCK_ERR Conditions

Condition Number	Condition Name and Description
0	<i>Other</i>
1	Block Configuration Error: the selected channel carries a measurement that is incompatible with the engineering units selected in XD_SCALE, the L_TYPE parameter is not configured, or CHANNEL = zero.
2	<i>Link Configuration Error</i>
3	Simulate Active: Simulation is enabled and the block is using a simulated value in its execution.
4	<i>Local Override</i>
5	<i>Device Fault State Set</i>
6	<i>Device Needs Maintenance Soon</i>
7	Input Failure/Process Variable has Bad Status: The hardware is bad, or a bad status is being simulated.
8	Output Failure: The output is bad based primarily upon a bad input.
9	<i>Memory Failure</i>
10	<i>Lost Static Data</i>
11	<i>Lost NV Data</i>
12	<i>Readback Check Failed</i>
13	<i>Device Needs Maintenance Now</i>
14	<i>Power Up</i>
15	Out of Service: The actual mode is out of service.

6.7 Alerts

The AMS Device Manager lets you view active alerts. The alarm parameters (FD_FAIL_ALM, FD_OFFSPEC_ALM, FD_MAINT_ALM, and FD_CHECK_ALM) contain information regarding some of the device errors. Active error conditions are displayed in the FD_xxx_ACTIVE parameter and can easily be listed by using the Service Tools option in AMS Device Manager. See [Field diagnostic alerts](#) for more information on the different alert types.

6.7.1 Viewing active alerts in AMS Device Manager

Procedure

1. From the **Start** menu; open the **AMS Device Manager** application.
2. Open the **View** → **Device Connection View**.
3. Double-click the FF network icon and expand the network node to view the devices.
4. Right-click or double-click the desired gauge icon to open the list of menu options:

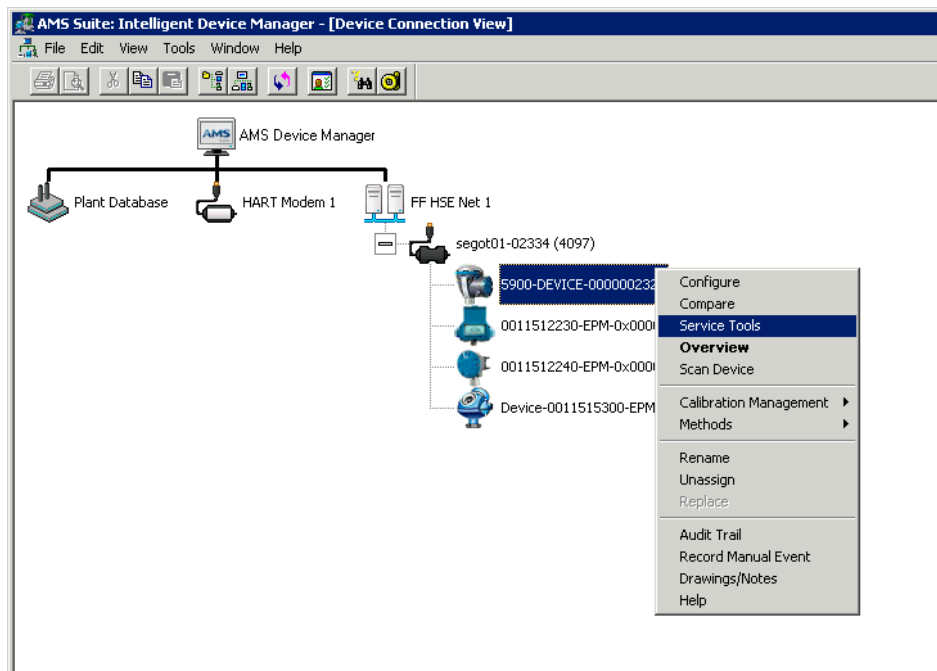

5. Select the **Service Tools** option.
6. In the *Navigation Pane* select the **Alerts** option

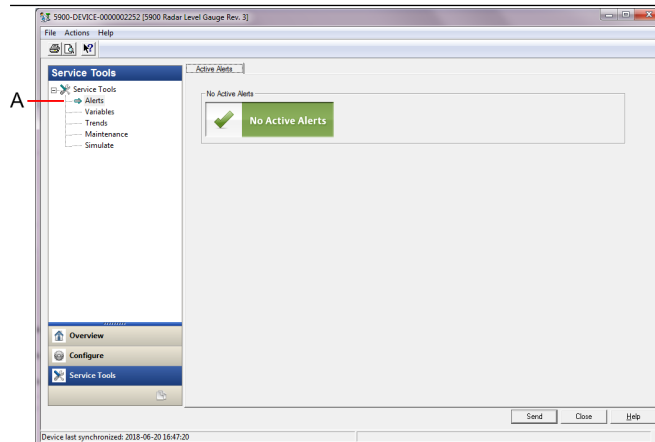

A. Alerts

The **Active Alerts** tab shows the alerts that are currently active. All types of alerts can be shown; Failure, Out of Specification, Maintenance Required, and Function Check. A brief description of the error is presented as well as the recommended action.

- Alerts are listed in order of priority beginning with Failure. By scrolling down you will see Out of Specification, Maintenance Required, and Function Check alerts as well. See [Viewing device status in AMS Device Manager](#) for more information.

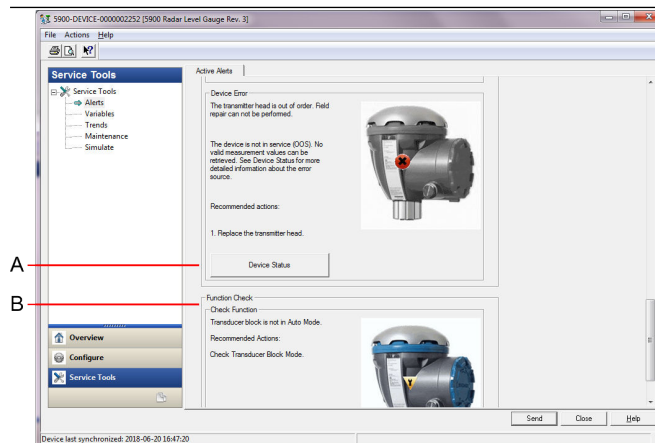

- Device Status
- Active Alerts

See [Alert setup](#) for details on how to setup alerts for the Rosemount 5900S Radar Level Gauge.

6.7.2 Recommended actions

The `FD_RECOMMEN_ACT` parameter displays a text string that will give a recommended course of action to take based on which type and which specific event of the alerts are active, see [Table 6-10](#).

Table 6-10: RECOMMENDED_ACTION

Alert Type	Host Diagnostic Message	Description	Recommended Action
None	N/A	None	No action required
Failure	Software Incompatibility Error	FF I/O Board software and radar level gauge main firmware versions are incompatible. The device is not in service (OOS).	<ol style="list-style-type: none"> 1. Replace the transmitter head. 2. Contact Emerson Automation Solutions/Rosemount Tank Gauging department.
	Memory Failure - FF I/O Board	Configuration data has been corrupted or pending configuration changes has been lost due to power loss before data storage was completed. Default values are loaded into the faulty block. Potential errors in stored data may cause unwanted behavior. The device is not in service (OOS) and status for all variables is BAD. Device recovery is possible.	<ol style="list-style-type: none"> 1. Do Factory Reset - FF I/O Board. 2. If error persists, it may indicate a faulty memory chip. Replace the transmitter head.
	Device Error	The transmitter head is out of order. Field repair might be possible. The device is not in service (OOS). No valid measurement values can be retrieved.	<ol style="list-style-type: none"> 1. Replace the transmitter head.
	Internal Communication Failure	The communication between the radar level gauge main board and the FF I/O Board has been lost	<ol style="list-style-type: none"> 1. Replace the transmitter head.
	Electronics Failure	The device has detected a fault with an electrical component on the FF I/O Board module assembly. The device is not in service (OOS).	<ol style="list-style-type: none"> 1. Replace the transmitter head.
Out of Specification	Device Major Information	Measurement values are retrieved but device needs to be serviced. Problem with installation or physical environment that might affect measurement and device behavior in the long term. See Device Status for more information on the error source (see Viewing device status in AMS Device Manager).	<ol style="list-style-type: none"> 1. Check the mechanical installation and environment.

Table 6-10: RECOMMENDED_ACTION (continued)

Alert Type	Host Diagnostic Message	Description	Recommended Action
	Device Warning	Measurement values can not be retrieved. Last good value with a BAD status is displayed. Field repair might be possible.	<ol style="list-style-type: none"> 1. Restart the level measurement. 2. Cycle power to the device by disconnecting the FF bus. 3. Factory reset measurement configuration and reconfigure device. 4. If error persists, contact Emerson Automation Solutions/ Rosemount Tank Gauging department.
Maintenance Required	Device Minor Information	Unexpected measurement values retrieved due to configuration related problem.	<ol style="list-style-type: none"> 1. Check configuration of the device. <p>See Device Status for more information on the error source (see Viewing device status in AMS Device Manager).</p>
Function Check	Check function	Transducer Block is not in Auto Mode	<p>Regular preparation work is in progress. One or more Transducer Blocks are in Out of Service mode.</p> <ol style="list-style-type: none"> 1. Return Transducer Block to Auto mode.

6.8 Viewing device status in AMS Device Manager

To view the current device status:

Procedure

1. Start AMS Device Manager and open the **View** → **Device Connection View**.
2. Double-click the FF network icon and expand the network node to view the devices.
3. Right-click or double-click the desired gauge icon to open the list of menu options.
4. Choose **Service Tools**.

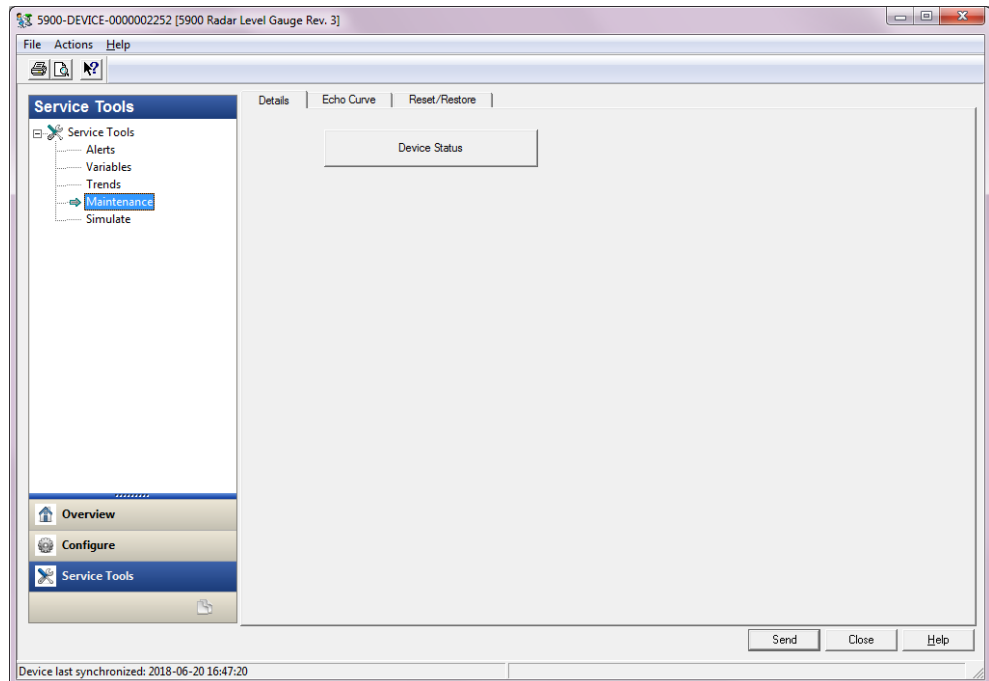

5. In the *Navigation Pane* select the **Maintenance** option.
6. Select the **Details** tab and click the **Device Status** button.
7. In the *Device Status* tab, check boxes indicate the current status of the device grouped in separate categories. See also [Device status](#). See [Alert setup](#) for details on how to setup alerts for the Rosemount 5900S Radar Level Gauge.

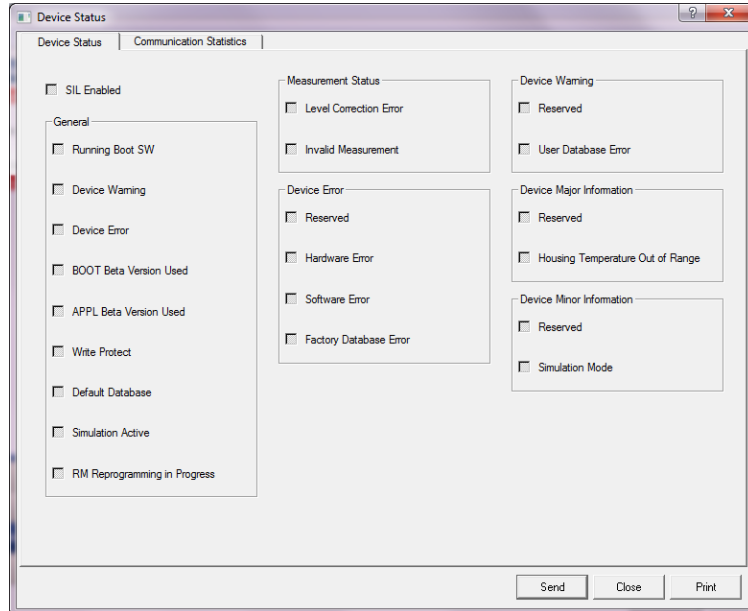

The *Communication Statistics* tab shows you the internal communication statistics. This may be a useful tool for troubleshooting in case of communication warnings or errors.

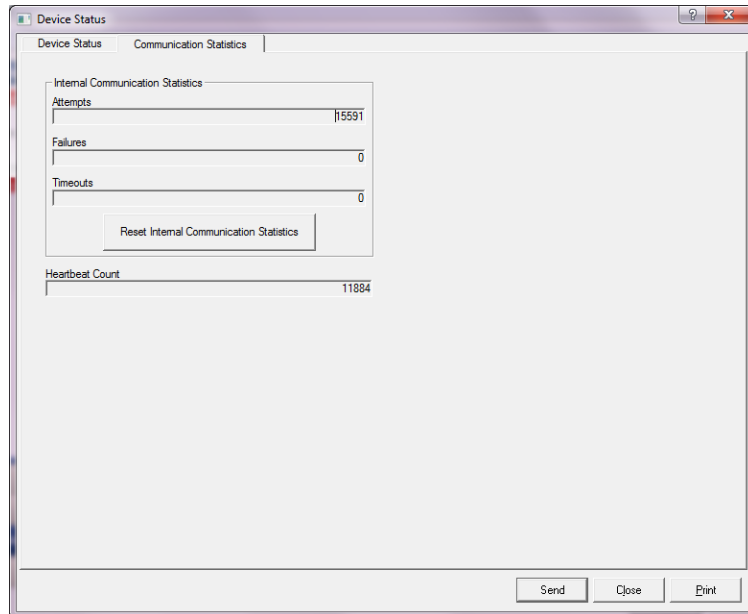

A Specifications and reference data

A.1 General

A.1.1 Instrument accuracy

Rosemount 5900S standard version ± 0.5 mm (0.020 in.)

Rosemount 5900S 2-in-1 version ± 0.5 mm (0.020 in.)⁽¹⁴⁾

Instrument accuracy is under reference conditions. Reference conditions are: Measurement in test bench at Rosemount Tank Radar AB in Mölnlycke Sweden. Test bench is calibrated minimum yearly by an accredited laboratory (SP Technical Research Institute of Sweden. Measuring range is up to 30 m (98 ft). Ambient temperature and humidity is close to constant during tests. Total uncertainty in test bench is below 0.15 mm (0.006 in.).

A.1.2 Temperature stability

Typically < ± 0.5 mm (0.020 in.) in -40 to +70 °C (-40 to +158 °F)

A.1.3 Fieldbus (standard)

FOUNDATION™ Fieldbus FISCO (Tankbus)

A.1.4 Update time

New measurement every 0.3 s

A.1.5 Repeatability

0.2 mm (0.008 in.)

A.1.6 Maximum level rate

Up to 200 mm/s

A.1.7 Metrology sealing possibility

Yes

⁽¹⁴⁾ Some level offset may be expected on the secondary unit.

A.1.8 Installation considerations

See [Installation considerations](#).

A.1.9 Measurement principle

The FMCW-method (Frequency Modulated Continuous Wave) means that the transmitted radar signal has a linear frequency variation around 10 GHz. The reflection from the liquid surface has a slightly different frequency compared with the signal transmitted from the antenna when the reflection is received. The difference in frequency is directly proportional to the distance between the antenna and the liquid surface, and thereby also the liquid level. This technology enables a very accurate and stable measured value.

Figure A-1: Principle of FMCW Technology

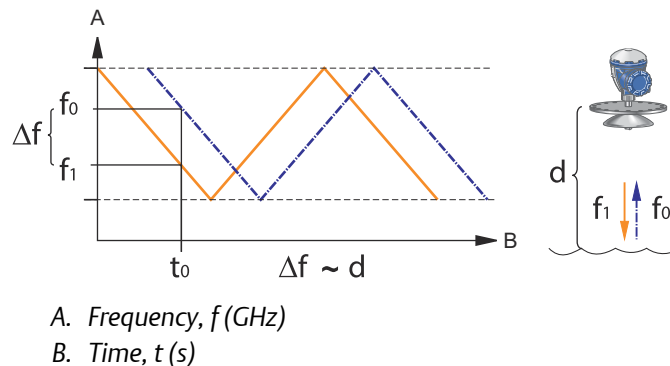

A.2 Communication / Display / Configuration

A.2.1 Output variables and units

- Level, and ullage: meter, centimeter, millimeter, feet, or inch
- Level rate: meter/second, meter/hour, feet/second, feet/hour, inch/minute
- Signal strength: mV

A.2.2 Configuration tools

Rosemount TankMaster WinSetup, Field Communicator

A.3 FOUNDATION™ Fieldbus characteristics

Polarity sensitive

No

Quiescent current draw

51 mA

Lift-off minimum voltage

9.0 VDC

Device capacitance / inductance

See [Product Certifications](#).

Class (Basic or Link Master)

Link Master (LAS)

Number of available VCRs

Maximum 20, including one fixed

Links

Maximum 40

Minimum slot time / maximum response delay/ minimum intermessage delay

8/5/8

Blocks and Execution time

Table A-1: Execution Time

Block	Execution time
1 Resource block	N/A
5 Transducer blocks (Level, Register, Adv_Config, Volume, and LPG)	N/A
6 Analog Input (AI)	10 ms
2 Analog Output (AO)	10 ms
1 Proportional/Integral/Derivate (PID)	15 ms
1 Signal Characterizer (SGCR)	10 ms
1 Integrator (INT)	10 ms
1 Arithmetic (ARTH)	10 ms
1 Input Selector (ISEL)	10 ms
1 Control Selector (CS)	10 ms
1 Output Splitter (OS)	10 ms

For more information, see the FOUNDATION Fieldbus Blocks [Manual](#).

Instantiation

Yes

Conforming FOUNDATION Fieldbus

ITK 6

Field Diagnostics support

Yes

Action support wizards

Restart measurement, write protect device, factory reset - measurement configuration, start/stop device simulation, set as surface, reset statistics, change all modes, register/remove false echo, refresh echo peaks, pin verification, change vapor pressure, change vapor temperature.

Advanced diagnostics

Software, memory/database, electronics, internal communication, simulation, level correction, level measurement, ambient temperature, vapor pressure/temperature correction, LPG verification pin, and manual measurement values.

A.4 Electric

A.4.1 Tankbus cabling

0.5-1.5 mm² (AWG 22-16), twisted shielded pairs

A.4.2 Power supply

FISCO: 9.0 - 17.5 VDC polarity insensitive (for example from Rosemount 2410 Tank Hub)
Entity: 9.0 - 30.0 VDC polarity insensitive

A.4.3 Bus current draw

50 mA (100 mA for the 2-in-1 version)

A.4.4 Microwave output power

< 1 mW

A.4.5 Build-in Tankbus terminator

Yes (to be connected if required)

A.4.6 Daisy chain possibility

Yes

A.5 Mechanical

A.5.1 Housing material & surface treatment

Polyurethane-coated die-cast aluminum

A.5.2 Cable entry (connection/glands)

Two ½ - 14 NPT entries for cable glands or conduits. One metal plug to seal any unused port is enclosed in the transmitter delivery.

Optional:

- M20 x 1.5 conduit / cable adapter
- Cable glands in metal (½ - 14 NPT)
- 4-pin male eurofast connector or A size Mini 4-pin male minifast connector

A.5.3 Total weight

Table A-2: Weight of Transmitter Head

Transmitter head	Weight
Rosemount 5900S single version	5.1 kg (11.2 lbs)
Rosemount 5900S 2-in-1 version	5.4 kg (11.9 lbs)

Table A-3: Weight With Antenna

Transmitter head with antenna	Weight
Rosemount 5900S with horn antenna	Appr. 12 kg (26 lbs)
Rosemount 5900S with parabolic antenna	Appr. 17 kg (37 lbs)
Rosemount 5900S with still-pipe array antenna	Appr. 13.5-24 kg (30-53 lbs)
Rosemount 5900S with LPG/LNG antenna, 6-in. 150 psi	Appr. 30 kg (66 lbs)
Rosemount 5900S with LPG/LNG antenna, 6-in. 300 psi	Appr. 40 kg (88 lbs)

A.5.4 Antennas

The Rosemount 5900S antennas have a drip-off design which for some versions also include inclined polished PTFE surfaces. Condensation on the antenna is minimized, and the radar signal remains strong. This results in maintenance free operation, high accuracy and reliability. There is always a suitable antenna for every tank type, tank opening and application:

- Parabolic
- Horn
- Still-pipe array
- LPG/LNG

A.5.5 Transmitter head

The same transmitter head is used for all Rosemount 5900S antenna types, minimizing spare part requirements:

- The dual compartment transmitter housing, with electronics and cabling separated, can be replaced without opening the tank
- It is protected against lightning, moisture/rain, and has a surface protection against sulphur and salt spray atmospheres
- Electronics consists of one or two encapsulated units. The 2-in-1 solution has duplicate, galvanically isolated electronic units in the same housing
- No need for re-calibration

A.6 Environment

A.6.1 Ambient operating temperature

-40 to +70 °C (-40 to +158 °F). Minimum start-up temperature is -50 °C (-58 °F)

A.6.2 Storage temperature

-50 to +85 °C (-58 to +185 °F)

A.6.3 Humidity

0-100% relative humidity

A.6.4 Ingress protection

IP 66/67 and NEMA[®] 4X

A.6.5 Vibration resistance

IEC 60770-1 level 1 and IACS UR E10 test 7

A.6.6 Telecommunication

Compliance with:

- FCC 15B Class A, and 15C
- RED (EU directive 2014/53/EU) ETSI EN 302372; EN 50371
- IC (RSS210-5)

A.6.7 Electromagnetic compatibility

- EMC (EU directive 2014/30/EU) EN 61326-1; EN 61326-3-1
- OIML R85:2008

A.6.8 Transient / built-in lightning protection

According to IEC 61000-4-5, level 2 kV line to ground. Complies with IEEE 587 Category B transient protection and IEEE 472 surge protection.

A.6.9 Low Voltage Directive (LVD)

LVD (EU directive 2014/35/EU) EN/IEC 61010-1

A.7 Rosemount 5900S SIL 2 version (SIS option code S)

A.7.1 Rosemount 5900S 2-in-1 version

Separation

Galvanically separated gauge electronics, and shared antenna for the two units

Wiring

Separated or common

Tank hub connection

- Connection of both units to one hub, or
- Separate connection of units to two different hubs

Built-in Tankbus terminator

Single Tankbus connection: Yes (to be connected if required).

Dual Tankbus connection: Possible to terminate the primary Tankbus.

Daisy chain possibility

Yes

A.8 Rosemount 5900S SIL 3 version (SIS option code 3)

Measuring range

1.2 to 30 m (3.9 to 100 ft) below flange.

Separation

Galvanically separated gauge electronics, and shared antenna

Built-in Tankbus terminator

No

Daisy chain possibility

Yes

Electric properties for intrinsically safe alarm signal

12.5 VDC, 1-2 mA for normal condition (no alarm)

Wiring

- Additional separate 2-wire cable for alarm or
- A single cable incorporating two 2-wire cables (alarm and level)

For cable specification, see [Cable entry \(connection/glands\)](#)

A.9 Rosemount 5900S with parabolic antenna

Operating temperature in tank

Max. +180 °C (+356 °F) with FEP O-ring, or +230 °C (+445 °F) with Kalrez® O-ring

Measuring range

0.8 to 30 m (2.6 to 100 ft) below flange.

Possibility to measure 0.5 to 50 m (1.6 to 164 ft). Accuracy may be reduced. For longer measuring range, consult your local representative.

Pressure range

Clamped/threaded: -0.2 to 0.2 bar (-2.9 to 2.9 psig)

Welded: -0.2 to 10 bar (-2.9 to 145 psig)

Material exposed to tank atmosphere

Antenna: Material corresponds to AISI 316/316L and EN 1.4401 /1.4404

Sealing: PTFE

O-ring: FEP, or Kalrez®

Antenna dimension

440 mm (17 in.)

Manway size and installation

500 mm (20-in.) opening.

The parabolic antenna is installed on the manway cover by using the flange ball. It is designed for easy adjustment of the antenna inclination and orientation within the specified limits.

The flexible flange ball can be installed on both horizontal or inclined manways without any special arrangements.

A.10 Rosemount 5900S with horn antenna

Operating temperature in tank

Max. +180 °C (+356 °F)

Measuring range

0.8 to 20 m (2.6 to 65 ft) below flange.

Possibility to measure 0.5 to 30 m (1.6 to 100 ft). Accuracy may be reduced. For longer measuring range, consult your local representative.

Pressure range

-0.2 to 2 bar (-2.9 to 29 psig)

Material exposed to tank atmosphere

Antenna and flange: Material corresponds to AISI 316/316L and EN 1.4401 /1.4404

Sealing: PTFE

O-ring: Viton®

Antenna dimension

175 mm (7 in.)

Nozzle diameter

Minimum 200 mm (8 in.)

Tank connection

The flange can be horizontal or 4° inclined for installation close to the tank wall.

The horizontal flange is used when highest accuracy and reliability is required. The 4° inclined version can be used to maintain high accuracy when the gauge is installed close to the tank wall.

A.11 Rosemount 5900S with still-pipe array antenna

Operating temperature in tank

-40 to 120 °C (-40 to 248 °F)

Measuring range

0.8 to 30 m (2.6 to 100 ft) below flange.

Possibility to measure 0.5 to 40 m (1.6 to 130 ft). Accuracy may be reduced. For longer measuring range, consult your local representative.

Pressure range

Fixed version: -0.2 to 2 bar (-2.9 to 29 psig) at 20 °C (68 °F).

Hinged hatch version: -0.2 to 0.5 bar (-2.9 to 7.2 psig) for 5 to 8-in. pipes.

-0.2 to 0.25 bar (-2.9 to 3.6 psig) for 10 and 12-in. pipes.

Material exposed to tank atmosphere

Antenna: Polyphenylenesulphide (PPS)

Sealing: PTFE

O-ring: FMVQ

Flange: Material corresponds to AISI 316/316L and EN 1.4401 /1.4404

Still-pipe dimensions

5-, 6-, 8-, 10- or 12 in.

Tank connection

5 in. hole pattern according to ANSI 5 in. Class 150

6 in. hole pattern according to ANSI 6 in. Class 150 / DN 150 PN 16

8 in. hole pattern according to ANSI 8 in. Class 150 / DN 200 PN 10

10 in. hole pattern according to ANSI 10 in. Class 150 / DN 250 PN 16

12 in. hole pattern according to ANSI 12 in. Class 150

Low Loss Mode

To get the accuracy, required for custody transfer bulk liquid storage applications, the antenna uses Low Loss Mode technology, invented for Rosemount Tank Gauging products, to transmit radar waves in the still-pipe center.

This virtually eliminates signal and accuracy degradation due to rust and product deposits inside the still-pipe.

A.12 Rosemount 5900S with LPG/LNG antenna

Operating temperature at ball valve

-55 to 90 °C (-67 to 194 °F)

Operating temperature in tank

-170 to 90 °C (-274 to 194 °F)

Measuring range

1.2 to 30 m (3.9 to 100 ft) below flange.

Possibility to measure 0.8 to 60 m (2.6 to 200 ft). Accuracy may be reduced. For longer measuring range, consult your local representative.

Pressure range

-1 to 25 bar (-14.5 to 365 psig).

Note! Flanges may have higher pressure rating than 25 bar, but maximum tank pressure is still 25 bar.

Pressure sensor (option)

Rosemount 2051. It is available with various hazardous location certifications, see [Product Certifications](#).

For more information see the Rosemount 2051 [Product Data Sheet](#).

Material exposed to tank atmosphere

Antenna and flange: Material corresponds to AISI 316/316L and EN 1.4401 /1.4404

Sealing: PTFE

Still-pipe dimension compatibility

Antenna choices for 4-in. sch. 10, 4-in. sch 40, or 100 mm (99 mm inner diameter) still-pipe dimensions

Flange size and rating

4 in. Class 150/300

6 in. Class 150/300

8 in. Class 150/300

Pressure seal

The pressure seal includes a double-block function, consisting of a PTFE seal and a fire-proof ball valve. A pressure sensor enables correction due to vapor for best measurement performance.

Verification possibility

A patented reference device function enables measurement verification with the tank in service. A verification pin mounted in a still-pipe hole, and a deflection plate with a verification ring at the lower still-pipe end provide reference echoes at fixed pre-defined distances.

A.13 Dimensional drawings

Figure A-2: Dimensions of Rosemount 5900S with Parabolic Antenna

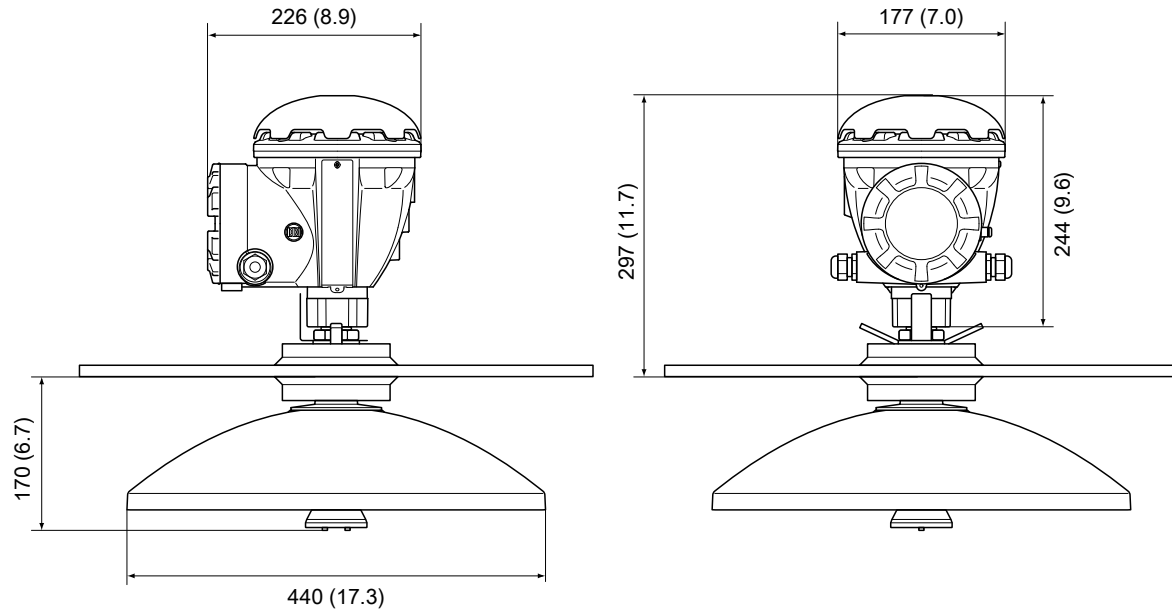

Dimensions are in millimeters (inches).

Figure A-3: Dimensions of Rosemount 5900S with Horn Antenna

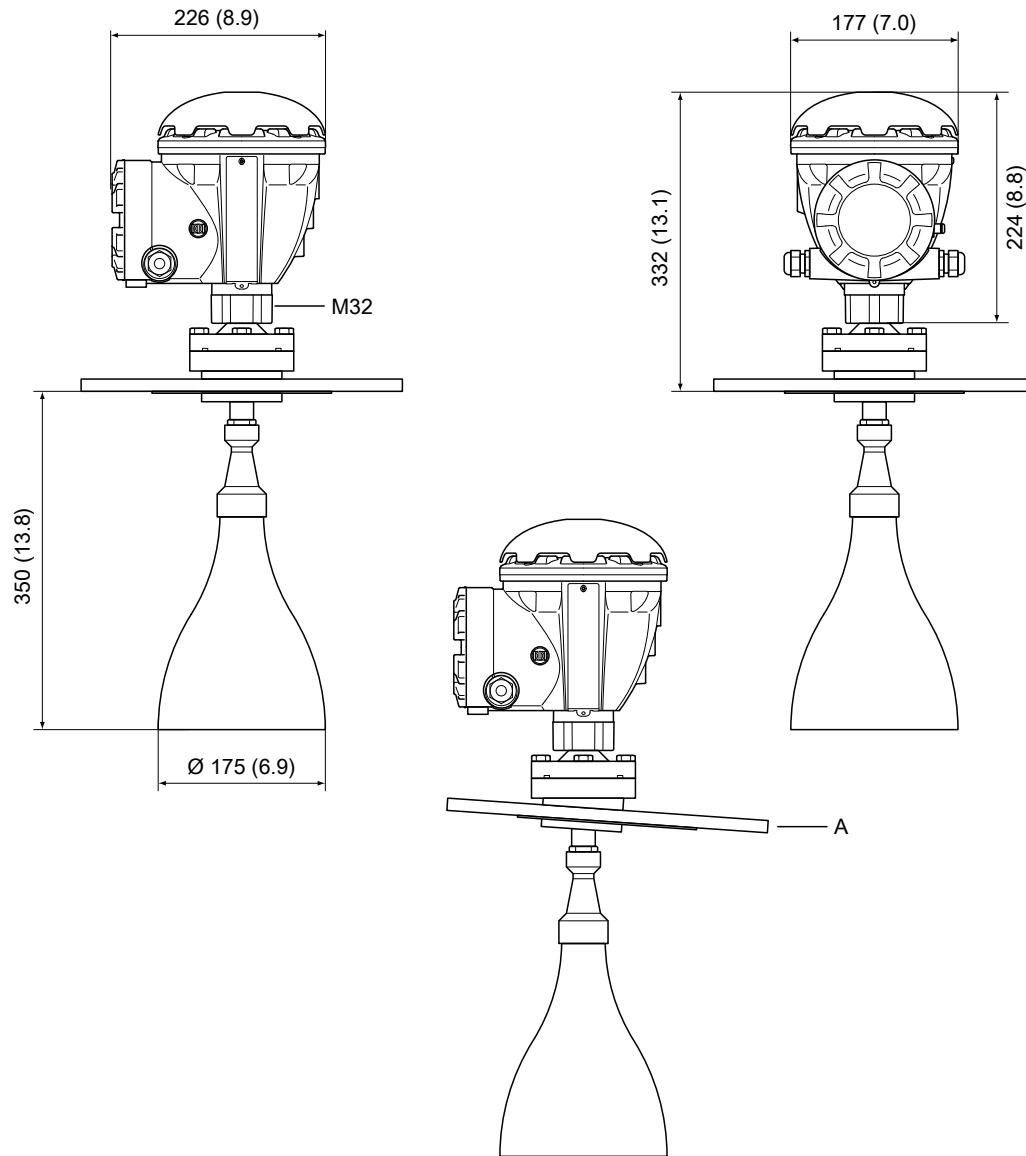

A. Flange Inclined 4°

Dimensions are in millimeters (inches).

Figure A-4: Dimensions of Rosemount 5900S with Still-Pipe Array Antenna

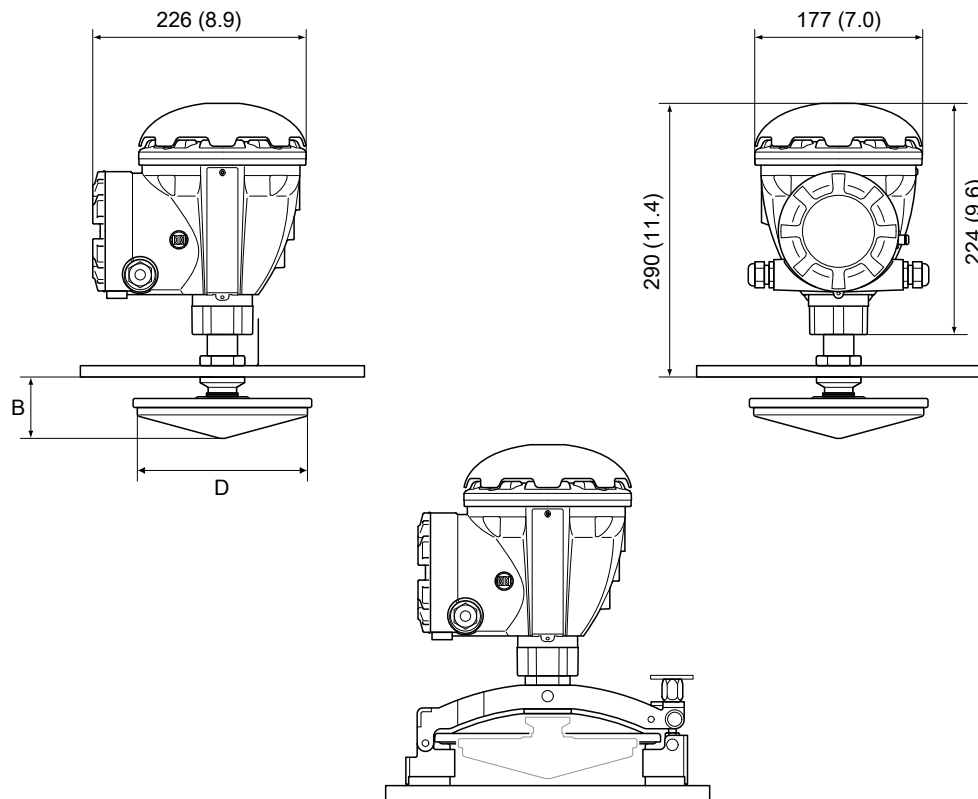

Dimensions are in millimeters (inches).

Table A-4: Available sizes for Still-Pipe Array Antenna

Antenna diameter (D)	B (mm)
5 in. / DN125 (Ø 120 mm)	56
6 in. / DN150 (Ø 145 mm)	59
8 in. / DN200 (Ø 189 mm)	65
10 in. / DN250 (Ø 243 mm)	73
12 in. / DN300 (Ø 293 mm)	79

Figure A-5: Dimensions of Rosemount 5900S with LPG/LNG Still-Pipe Antenna

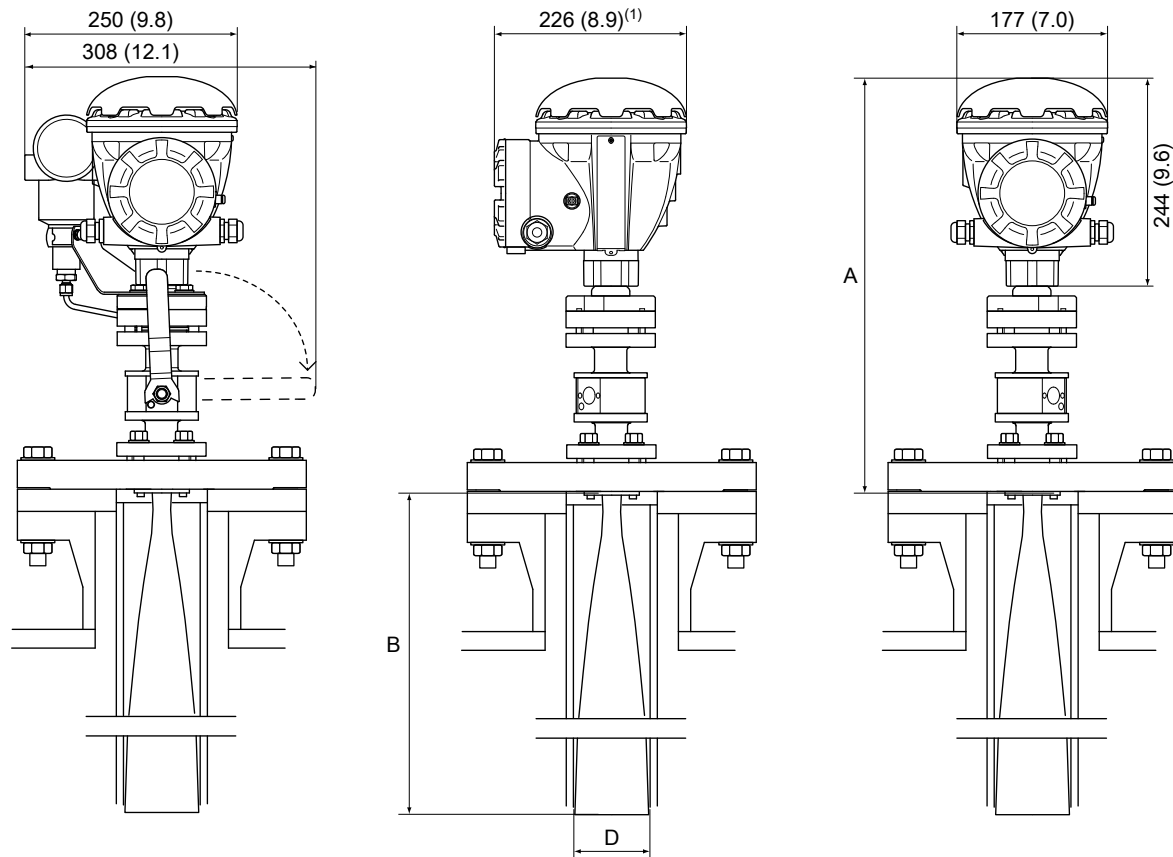

A. max. 490 (19.3), depending on flange type

1. 302 mm with pressure transmitter

Dimensions are in millimeters (inches).

Table A-5: Available sizes for LPG/LNG Still-Pipe antenna

Antenna diameter (D)	B (mm)
4 in. Sch10 (Ø 107 mm)	752
4 in. Sch40 (Ø 101 mm)	534
DN100 (Ø 99 mm)	502

A.14 Ordering information

A.14.1 Rosemount 5900S Radar Level Gauge with parabolic antenna

Table A-6: Rosemount 5900S Radar Level Gauge with Parabolic Antenna Ordering Information

Model	Product Description
5900S	Radar Level Gauge
Performance class	
P	Premium: ±0.5 mm (0.020 in.) instrument accuracy
Safety certification (SIS)	
3 ⁽¹⁾	Certified IEC 61508 SIL 3 capable
S ⁽²⁾	Certified IEC 61508 SIL 2 capable
F	None. Ready for upgrade to Safety certification (SIS)
0	None
Redundancy	
2	2-in-1: Dual independent radar level gauge electronics
F	None. Ready for upgrade to 2-in-1
1	None. Single radar level gauge electronics
Tankbus: Power and communication	
F	Bus powered 2-wire FOUNDATION™ Fieldbus (IEC 61158)
Hazardous location certification	
I1	ATEX Intrinsic Safety
I7	IECEx Intrinsic Safety
I5	FM-US Intrinsic Safety
I6	FM-Canada Intrinsic Safety
I2	INMETRO Intrinsic Safety (Brazil)
IP ⁽³⁾	KC Intrinsic Safety (South Korea)
IW	CCOE/PESO Intrinsic Safety (India)
I4 ⁽⁴⁾	Japan Intrinsic Safety
IM	Technical Regulations Customs Union (EAC) Intrinsic Safety
NA	None
Custody transfer type approval⁽⁵⁾	
R ⁽⁶⁾⁽⁷⁾	OIML R85 edition 2008
A ⁽⁶⁾⁽⁷⁾	CMI (Czech Republic)
B ⁽⁶⁾⁽⁷⁾	NMI (Australia)

Table A-6: Rosemount 5900S Radar Level Gauge with Parabolic Antenna Ordering Information
(continued)

C ⁽⁶⁾ (8)	PTB Eich (Germany)
E ⁽⁶⁾ (7)	TJA (Estonia)
G ⁽⁶⁾ (7)	GUM (Poland)
I ⁽⁷⁾ (9)	Ministero (Italy)
K ⁽⁶⁾ (7)(10)	GOST (Kazakhstan)
L ⁽⁹⁾ (11)	LNE (France)
M ⁽⁷⁾ (9)	BMS (Belgium)
N ⁽⁹⁾ (12)	NMi (The Netherlands)
O ⁽⁶⁾ (7)	ONML (Algeria)
Q ⁽⁶⁾ (7)	IPQ (Portugal)
S ⁽⁶⁾ (7)(10)	GOST (Russia)
T ⁽⁷⁾ (9)	ANM (Tunisia)
W ⁽⁶⁾ (7)	METAS (Switzerland)
Y ⁽⁶⁾ (7)	Justervesenet (Norway)
0	None
Level measurement method	
1	10 GHz FMCW radar technology
2	10 GHz FMCW radar technology for US installation
Housing	
A	Standard enclosure, polyurethane-covered aluminum. IP 66/67
Cable entry/Conduit connections	
1	½ - 14 NPT, female thread. (1 plug included)
2	M20 x 1.5 adapters, female thread. (2 adapters and 1 plug included)
G	Metal cable glands (½ - 14 NPT). Minimum temperature -20 °C (-4 °F). ATEX/IECEX Exe approved. (2 glands and 1 plug included)
E	eurofast [®] male connector (1 plug included)
M	minifast [®] male connector (1 plug included)
Antenna	
1P	Parabolic antenna
Antenna size	
F	20 in./DN 500, Ø=440 mm (17.3 in.)
Antenna material	
S	SST AISI 316L/EN 1.4436

Table A-6: Rosemount 5900S Radar Level Gauge with Parabolic Antenna Ordering Information
(continued)

Tank seal	
PF	PTFE with FEP fluoropolymer O-ring
PK	PTFE with Kalrez® perfluoroelastomer O-ring
Tank connection	
WE	Welded installation
CL	Clamped/threaded installation
Antenna options	
0	None
V ⁽¹³⁾	Proof test verification reflector
Options (include with selected model number)	
Safety certificate	
QT ⁽¹⁴⁾	IEC 61508 certificate and FMEDA-data (printed copy)
Calibration certificate	
Q4	Calibration certificate (printed copy)
S4	Witnessed calibration certificate (witnessed by factory selected accredited third party)
Material traceability certificate	
Q8 ⁽¹⁵⁾	Antenna material traceability certification per EN 10204 3.1
Overfill protection approval	
U1 ⁽¹⁶⁾	TÜV/DIBt WHG approval for overfill protection
U2	SVTI approval for overfill protection (Switzerland)
Tag plate	
ST	Engraved SST tag plate
Extended warranty	
WR3	3-year limited warranty
WR5	5-year limited warranty
Typical Model Number: 5900S P S F F I5 L 2 A 1 1 P F S P F WE 0 Q4	

- (1) Requires Redundancy code 2 and Rosemount 2410 with Safety certification (SIS) code 3.
- (2) Requires Rosemount 2410 with either Analog output 4-20 mA or Relay output code 1 or 2.
- (3) Requires Custody transfer type approval code R or 0.
- (4) Not available with Cable entry/Conduit connections code E or M.
- (5) Requires the same Custody transfer type approval code for both the Rosemount 2410 and the Rosemount 5900S.
- (6) Requires Options code Q4.
- (7) Requires integral display in Rosemount 2410 or Rosemount 2230 or Rosemount TankMaster.
- (8) Requires integral display in Rosemount 2410 or Rosemount 2230 with Custody transfer approval code C or Rosemount TankMaster.
- (9) Requires Options code S4.
- (10) Requires Hazardous location certification code I1.

- (11) Requires integral display in Rosemount 2410 or Rosemount 2230 with Custody transfer approval code L or Rosemount TankMaster.*
- (12) Requires integral display in Rosemount 2410 or Rosemount 2230 with Custody transfer approval code N or Rosemount TankMaster.*
- (13) Not available with Options code U1.*
- (14) Requires Safety certification (SIS) code 3 or S.*
- (15) Not available for transmitter head sparepart.*
- (16) Requires one or more relay outputs in the Rosemount 2410 Tank Hub.*

A.14.2 Rosemount 5900S Radar Level Gauge with horn antenna

Table A-7: Rosemount 5900S Radar Level Gauge with Horn Antenna Ordering Information

Model	Product Description
5900S	Radar Level Gauge
Performance class	
P	Premium: ±0.5 mm (0.020 in.) instrument accuracy
Safety certification (SIS)	
3 ⁽¹⁾	Certified IEC 61508 SIL 3 capable
S ⁽²⁾	Certified IEC 61508 SIL 2 capable
F	None. Ready for upgrade to Safety certification (SIS)
0	None
Redundancy	
2	2-in-1: Dual independent radar level gauge electronics
F	None. Ready for upgrade to 2-in-1
1	None. Single radar level gauge electronics
Tankbus: Power and communication	
F	Bus powered 2-wire FOUNDATION™ Fieldbus (IEC 61158)
Hazardous location certification	
I1	ATEX Intrinsic Safety
I7	IECEX Intrinsic Safety
I5	FM-US Intrinsic Safety
I6	FM-Canada Intrinsic Safety
I2	INMETRO Intrinsic Safety (Brazil)
IP ⁽³⁾	KC Intrinsic Safety (South Korea)
IW	CCOE/PESO Intrinsic Safety (India)
I4 ⁽⁴⁾	Japan Intrinsic Safety
IM	Technical Regulations Customs Union (EAC) Intrinsic Safety
NA	None
Custody transfer type approval⁽⁵⁾	
R ⁽⁶⁾⁽⁷⁾	OIML R85 edition 2008
A ⁽⁶⁾⁽⁷⁾	CMI (Czech Republic)
B ⁽⁶⁾⁽⁷⁾	NMI (Australia)
C ⁽⁶⁾⁽⁸⁾	PTB Eich (Germany)
E ⁽⁶⁾⁽⁷⁾	TJA (Estonia)
G ⁽⁶⁾⁽⁷⁾	GUM (Poland)

Table A-7: Rosemount 5900S Radar Level Gauge with Horn Antenna Ordering Information (continued)

I ⁽⁷⁾⁽⁹⁾	Ministero (Italy)
K ⁽⁶⁾⁽⁷⁾⁽¹⁰⁾	GOST (Kazakhstan)
L ⁽⁹⁾⁽¹¹⁾	LNE (France)
M ⁽⁷⁾⁽⁹⁾	BMS (Belgium)
N ⁽⁹⁾⁽¹²⁾	NMi (The Netherlands)
O ⁽⁶⁾⁽⁷⁾	ONML (Algeria)
Q ⁽⁶⁾⁽⁷⁾	IPQ (Portugal)
S ⁽⁶⁾⁽⁷⁾⁽¹⁰⁾	GOST (Russia)
T ⁽⁷⁾⁽⁹⁾	ANM (Tunisia)
W ⁽⁶⁾⁽⁷⁾	METAS (Switzerland)
Y ⁽⁶⁾⁽⁷⁾	Justervesenet (Norway)
0	None
Level measurement method	
1	10 GHz FMCW radar technology
2	10 GHz FMCW radar technology for US installation
Housing	
A	Standard enclosure, polyurethane-covered aluminum. IP 66/67
Cable entry/Conduit connections	
1	½ - 14 NPT, female thread. (1 plug included)
2	M20 x 1.5 adapters, female thread. (2 adapters and 1 plug included)
G	Metal cable glands (½ - 14 NPT). Minimum temperature -20 °C (-4 °F). ATEX/IECEx Exe approved. (2 glands and 1 plug included)
E	euromast® male connector (1 plug included)
M	minifast® male connector (1 plug included)
Antenna	
1H	Horn antenna
Antenna size	
8	8 in. / DN 200, Ø=175 mm (6.9 in.)
Antenna material	
S	SST AISI 316/316L and SST EN 1.4401/1.4404
Tank seal	
PV	PTFE with Viton® fluoroelastomer O-ring
Tank connection	
ANSI Hole Pattern (SST AISI 316/316 L) – Flat Face	
8A	8 in. Class 150

Table A-7: Rosemount 5900S Radar Level Gauge with Horn Antenna Ordering Information (continued)

8Z	8 in. Class 150, inclined 4 degrees
EN Hole Pattern (SST EN 1.4401/1.4404) – Flat Face	
LA	DN 200/PN 10
LZ	DN 200/PN 10, inclined 4 degrees
Antenna options	
0	None
Options (include with selected model number)	
Safety certificate	
QT ⁽¹³⁾	IEC 61508 certificate and FMEDA-data (printed copy)
Calibration certificate	
Q4	Calibration certificate (printed copy)
S4	Witnessed calibration certificate (witnessed by factory selected accredited third party)
Material traceability certificate	
Q8 ⁽¹⁴⁾	Antenna material traceability certification per EN 10204 3.1
Overfill protection approval	
U1 ⁽¹⁵⁾	TÜV/DIBt WHG approval for overfill protection
U2	SVTI approval for overfill protection (Switzerland)
Tag plate	
ST	Engraved SST tag plate
Extended warranty	
WR3	3-year limited warranty
WR5	5-year limited warranty
Typical Model Number: 5900S PF 2 F I5 R 2 A G 1H 8 S PV 8Z 0 ST	

- (1) Requires Redundancy code 2 and Rosemount 2410 with Safety certification (SIS) code 3.
- (2) Requires Rosemount 2410 with either Analog output 4-20 mA or Relay output code 1 or 2.
- (3) Requires Custody transfer type approval code R or 0.
- (4) Not available with Cable entry/Conduit connections code E or M.
- (5) Requires the same Custody transfer type approval code for both the Rosemount 2410 and the Rosemount 5900S.
- (6) Requires Options code Q4.
- (7) Requires integral display in Rosemount 2410 or Rosemount 2230 or Rosemount TankMaster.
- (8) Requires integral display in Rosemount 2410 or Rosemount 2230 with Custody transfer approval code C or Rosemount TankMaster.
- (9) Requires Options code S4.
- (10) Requires Hazardous location certification code I1.
- (11) Requires integral display in Rosemount 2410 or Rosemount 2230 with Custody transfer approval code L or Rosemount TankMaster.
- (12) Requires integral display in Rosemount 2410 or Rosemount 2230 with Custody transfer approval code N or Rosemount TankMaster.
- (13) Requires Safety certification (SIS) code 3 or S.
- (14) Not available for transmitter head sparepart.
- (15) Requires one or more relay outputs in the Rosemount 2410 Tank Hub.

A.14.3 Rosemount 5900S Radar Level Gauge with still-pipe array antenna

Table A-8: Rosemount 5900S Radar Level Gauge with Still-Pipe Array Antenna Ordering Information

Model	Product Description
5900S	Radar Level Gauge
Performance class	
P	Premium: ±0.5 mm (0.020 in.) instrument accuracy
Safety certification (SIS)	
3 ⁽¹⁾	Certified IEC 61508 SIL 3 capable
S ⁽²⁾	Certified IEC 61508 SIL 2 capable
F	None. Ready for upgrade to Safety certification (SIS)
0	None
Redundancy	
2	2-in-1: Dual independent radar level gauge electronics
F	None. Ready for upgrade to 2-in-1
1	None. Single radar level gauge electronics
Tankbus: Power and communication	
F	Bus powered 2-wire FOUNDATION™ Fieldbus (IEC 61158)
Hazardous location certification	
I1	ATEX Intrinsic Safety
I7	IECEx Intrinsic Safety
I5	FM-US Intrinsic Safety
I6	FM-Canada Intrinsic Safety
I2	INMETRO Intrinsic Safety (Brazil)
IP ⁽³⁾	KC Intrinsic Safety (South Korea)
IW	CCOE/PESO Intrinsic Safety (India)
I4 ⁽⁴⁾	Japan Intrinsic Safety
IM	Technical Regulations Customs Union (EAC) Intrinsic Safety
NA	None
Custody transfer type approval⁽⁵⁾	
R ⁽⁶⁾⁽⁷⁾	OIML R85 edition 2008
A ⁽⁶⁾⁽⁷⁾	CMI (Czech Republic)
B ⁽⁶⁾⁽⁷⁾	NMI (Australia)
C ⁽⁶⁾⁽⁸⁾	PTB Eich (Germany)
E ⁽⁶⁾⁽⁷⁾	TJA (Estonia)

Table A-8: Rosemount 5900S Radar Level Gauge with Still-Pipe Array Antenna Ordering Information
(continued)

G ⁽⁶⁾⁽⁷⁾	GUM (Poland)
I ⁽⁷⁾⁽⁹⁾	Ministero (Italy)
K ⁽⁶⁾⁽⁷⁾⁽¹⁰⁾	GOST (Kazakhstan)
L ⁽⁹⁾⁽¹¹⁾	LNE (France)
M ⁽⁷⁾⁽⁹⁾	BMS (Belgium)
N ⁽⁹⁾⁽¹²⁾	NMi (The Netherlands)
O ⁽⁶⁾⁽⁷⁾	ONML (Algeria)
Q ⁽⁶⁾⁽⁷⁾	IPQ (Portugal)
S ⁽⁶⁾⁽⁷⁾⁽¹⁰⁾	GOST (Russia)
T ⁽⁷⁾⁽⁹⁾	ANM (Tunisia)
W ⁽⁶⁾⁽⁷⁾	METAS (Switzerland)
Y ⁽⁶⁾⁽⁷⁾	Justervesenet (Norway)
0	None
Level measurement method	
1	10 GHz FMCW radar technology
2	10 GHz FMCW radar technology for US installation
Housing	
A	Standard enclosure, polyurethane-covered aluminum. IP 66/67
Cable entry/Conduit connections	
1	½ - 14 NPT, female thread. (1 plug included)
2	M20 x 1.5 adapters, female thread. (2 adapters and 1 plug included)
G	Metal cable glands (½ - 14 NPT). Minimum temperature -20 °C (-4 °F). ATEX/IECEx Exe approved. (2 glands and 1 plug included)
E	eurofast® male connector (1 plug included)
M	minifast® male connector (1 plug included)
Antenna	
1A	Still-pipe array antenna
Antenna size	
5	5 in./DN 125, Ø=120 mm (4.7 in.)
6	6 in./DN 150, Ø=145 mm (5.7 in.)
8	8 in./DN 200, Ø=189 mm (7.4 in.)
A	10 in./DN 250, Ø=243 mm (9.8 in.)
B	12 in./DN 300, Ø=293 mm (11.8 in.)

Table A-8: Rosemount 5900S Radar Level Gauge with Still-Pipe Array Antenna Ordering Information
(continued)

Antenna material	
S	SST (AISI 316L / EN 1.4404) and PPS (polyphenylene sulfide)
Tank seal	
FF	Fixed flange installation with fluorosilicone O-ring
HH	Integrated hatch installation with fluorosilicone O-ring (direct access to pipe with hand gauge)
Tank connection	
ANSI Hole Pattern (SST AISI 316/316 L) – Flat Face	
5A	5 in. Class 150
6A	6 in. Class 150
8A	8 in. Class 150
AA	10 in. Class 150
BA	12 in. Class 150
EN Hole Pattern (SST EN 1.4404) – Flat Face	
KA	DN 150 PN 16
LA	DN 200 PN 10
MB	DN 250 PN 16
Antenna options	
0	None
C	Clamp flange in galvanized steel (for still-pipes without a flange). Available for 6, 8, 10, and 12 in. tank connections.
V ⁽¹³⁾ (14)(15)	Proof test verification reflector (size equal to Tank connection)
Options (include with selected model number)	
Safety certificate	
QT ⁽¹⁶⁾	IEC 61508 certificate and FMEDA-data (printed copy)
Calibration certificate	
Q4	Calibration certificate (printed copy)
S4	Witnessed calibration certificate (witnessed by factory selected accredited third party)
Material traceability certificate	
Q8 ⁽¹⁷⁾	Antenna material traceability certification per EN 10204 3.1
Overfill protection approval	
U1 ⁽¹⁸⁾	TÜV/DIBt WHG approval for overfill protection
U2	SVTI approval for overfill protection (Switzerland)
Tag plate	
ST	Engraved SST tag plate

Table A-8: Rosemount 5900S Radar Level Gauge with Still-Pipe Array Antenna Ordering Information
(continued)

Extended warranty	
WR3	3-year limited warranty
WR5	5-year limited warranty
Typical Model Number: 5900S P F 1 F I5 R 2 A 1 1A 5 S FF AA C Q4	

- (1) Requires Redundancy code 2 and Rosemount 2410 with Safety certification (SIS) code 3.
- (2) Requires Rosemount 2410 with either Analog output 4-20 mA or Relay output code 1 or 2.
- (3) Requires Custody transfer type approval code R or 0.
- (4) Not available with Cable entry/Conduit connections code E or M.
- (5) Requires the same Custody transfer type approval code for both the Rosemount 2410 and the Rosemount 5900S.
- (6) Requires Options code Q4.
- (7) Requires integral display in Rosemount 2410 or Rosemount 2230 or Rosemount TankMaster.
- (8) Requires integral display in Rosemount 2410 or Rosemount 2230 with Custody transfer approval code C or Rosemount TankMaster.
- (9) Requires Options code S4.
- (10) Requires Hazardous location certification code I1.
- (11) Requires integral display in Rosemount 2410 or Rosemount 2230 with Custody transfer approval code L or Rosemount TankMaster.
- (12) Requires integral display in Rosemount 2410 or Rosemount 2230 with Custody transfer approval code N or Rosemount TankMaster.
- (13) Requires Antenna size 6 or 8.
- (14) Not available with Options code U1.
- (15) Requires Custody transfer type approval code 0 or R.
- (16) Requires Safety certification (SIS) code 3 or S.
- (17) Not available for transmitter head sparepart.
- (18) Requires one or more relay outputs in the Rosemount 2410 Tank Hub.

A.14.4 Rosemount 5900S Radar Level Gauge with LPG/LNG antenna

Table A-9: Rosemount 5900S Radar Level Gauge with LPG/LNG Antenna Ordering Information

Model	Product Description
5900S	Radar Level Gauge
Performance class	
P	Premium: ±0.5 mm (0.020 in.) instrument accuracy
Safety certification (SIS)	
3 ⁽¹⁾	Certified IEC 61508 SIL 3 capable
S ⁽²⁾	Certified IEC 61508 SIL 2 capable
F	None. Ready for upgrade to Safety certification (SIS)
0	None
Redundancy	
2	2-in-1: Dual independent radar level gauge electronics
F	None. Ready for upgrade to 2-in-1
1	None. Single radar level gauge electronics
Tankbus: Power and communication	
F	Bus powered 2-wire FOUNDATION™ Fieldbus (IEC 61158)
Hazardous location certification	
I1	ATEX Intrinsic Safety
I7	IECEx Intrinsic Safety
I5	FM-US Intrinsic Safety
I6	FM-Canada Intrinsic Safety
I2	INMETRO Intrinsic Safety (Brazil)
IP ⁽³⁾	KC Intrinsic Safety (South Korea)
IW	CCOE/PESO Intrinsic Safety (India)
I4 ⁽⁴⁾	Japan Intrinsic Safety
IM	Technical Regulations Customs Union (EAC) Intrinsic Safety
NA	None
Custody transfer type approval⁽⁵⁾	
R ⁽⁶⁾⁽⁷⁾	OIML R85 edition 2008
A ⁽⁶⁾⁽⁷⁾	CMI (Czech Republic)
B ⁽⁶⁾⁽⁷⁾	NMI (Australia)
C ⁽⁶⁾⁽⁸⁾	PTB Eich (Germany)
E ⁽⁶⁾⁽⁷⁾	TJA (Estonia)

Table A-9: Rosemount 5900S Radar Level Gauge with LPG/LNG Antenna Ordering Information (continued)

G ⁽⁶⁾⁽⁷⁾	GUM (Poland)
I ⁽⁷⁾⁽⁹⁾	Ministero (Italy)
K ⁽⁶⁾⁽⁷⁾⁽¹⁰⁾	GOST (Kazakhstan)
L ⁽⁹⁾⁽¹¹⁾	LNE (France)
M ⁽⁷⁾⁽⁹⁾	BMS (Belgium)
N ⁽⁹⁾⁽¹²⁾	NMi (The Netherlands)
O ⁽⁶⁾⁽⁷⁾	ONML (Algeria)
Q ⁽⁶⁾⁽⁷⁾	IPQ (Portugal)
Ϛ ⁽⁶⁾⁽⁷⁾⁽¹⁰⁾	GOST (Russia)
T ⁽⁷⁾⁽⁹⁾	ANM (Tunisia)
W ⁽⁶⁾⁽⁷⁾	METAS (Switzerland)
Y ⁽⁶⁾⁽⁷⁾	Justervesenet (Norway)
0	None
Level measurement method	
1	10 GHz FMCW radar technology
2	10 GHz FMCW radar technology for US installation
Housing	
A	Standard enclosure, polyurethane-covered aluminum. IP 66/67
Cable entry/Conduit connections	
1	½ - 14 NPT, female thread. (1 plug included)
2	M20 x 1.5 adapters, female thread. (2 adapters and 1 plug included)
G	Metal cable glands (½ - 14 NPT). Minimum temperature -20 °C (-4 °F). ATEX/IECEx Exe approved. (2 glands and 1 plug included)
E	eurofast [®] male connector (1 plug included)
M	minifast [®] male connector (1 plug included)
Antenna	
G1	LNG still-pipe antenna (with integrated ball-valve)
G2 ⁽¹³⁾	LPG/LNG still-pipe antenna (with integrated ball-valve and pressure transmitter)
G4 ⁽¹⁴⁾⁽¹³⁾	LPG/LNG still-pipe antenna (with integrated ball-valve and dual pressure transmitters)
Antenna size	
A	4 in. Schedule 10, Ø=107 mm (4.2 in.)
B	4 in. Schedule 40, Ø=101 mm (4.0 in.)
D	DN 100, Ø=99 mm (3.9 in.)
Antenna material	
S	SST AISI 316/316L and SST EN1.4401/1.4404

Table A-9: Rosemount 5900S Radar Level Gauge with LPG/LNG Antenna Ordering Information (continued)

Tank seal	
PT	PTFE sealing
Tank connection	
ANSI Flanges (SST AISI 316/316 L) – Raised Face	
1B ⁽¹⁵⁾⁽¹⁶⁾⁽¹⁷⁾	1.5 in. Class 300
2A ⁽¹⁵⁾⁽¹⁶⁾⁽¹⁷⁾	2 in. Class 150
2B ⁽¹⁵⁾⁽¹⁶⁾⁽¹⁷⁾	2 in. Class 300
3A ⁽¹⁵⁾⁽¹⁶⁾⁽¹⁷⁾	3 in. Class 150
3B ⁽¹⁵⁾⁽¹⁶⁾⁽¹⁷⁾	3 in. Class 300
4A	4 in. Class 150
4B	4 in. Class 300
6A	6 in. Class 150
6B	6 in. Class 300
8A	8 in. Class 150
8B	8 in. Class 300
Antenna options	
V	Measurement verification kit with 1 verification pin and 1 pipe end deflector kit
Options (include with selected model number)	
Safety certificate	
QT ⁽¹⁸⁾	IEC 61508 certificate and FMEDA-data (printed copy)
Calibration certificate	
Q4	Calibration certificate (printed copy)
S4	Witnessed calibration certificate (witnessed by factory selected accredited third party)
Material traceability certificate	
Q8 ⁽¹⁹⁾	Antenna material traceability certification per EN 10204 3.1
Overfill protection approval	
U1 ⁽²⁰⁾	TÜV/DIBt WHG approval for overfill protection
U2	SVTI approval for overfill protection (Switzerland)
Tag plate	
ST	Engraved SST tag plate
Hydrostatic pressure test	
P1	Antenna hydrostatic pressure testing
Extended warranty	
WR3	3-year limited warranty

Table A-9: Rosemount 5900S Radar Level Gauge with LPG/LNG Antenna Ordering Information (continued)

WR5	5-year limited warranty
Typical Model Number: 5900S P S F F I 5 R 2 A 1 G 1 B S Q A 4 B V S T	

- (1) Requires Redundancy code 2 and Rosemount 2410 with Safety certification (SIS) code 3.
- (2) Requires Rosemount 2410 with either Analog output 4-20 mA or Relay output code 1 or 2.
- (3) Requires Custody transfer type approval code R or 0.
- (4) Not available with Cable entry/Conduit connections code E or M.
- (5) Requires the same Custody transfer type approval code for both the Rosemount 2410 and the Rosemount 5900S.
- (6) Requires Options code Q4.
- (7) Requires integral display in Rosemount 2410 or Rosemount 2230 or Rosemount TankMaster.
- (8) Requires integral display in Rosemount 2410 or Rosemount 2230 with Custody transfer approval code C or Rosemount TankMaster.
- (9) Requires Options code S4.
- (10) Requires Hazardous location certification code I1.
- (11) Requires integral display in Rosemount 2410 or Rosemount 2230 with Custody transfer approval code L or Rosemount TankMaster.
- (12) Requires integral display in Rosemount 2410 or Rosemount 2230 with Custody transfer approval code N or Rosemount TankMaster.
- (13) Requires Hazardous location certification code I1, I2, I5, I6, I7, IP, I4 or IM.
- (14) Requires Redundancy code 2.
- (15) Requires Antenna size code A.
- (16) Requires Custody transfer type approval code R or 0.
- (17) Not available with Safety certification (SIS) code 3.
- (18) Requires Safety certification (SIS) code 3 or S.
- (19) Not available for transmitter head sparepart.
- (20) Requires one or more relay outputs in the Rosemount 2410 Tank Hub.

B Product Certifications

Rev 7.15

B.1 European directive information

The most recent revision of the EU Declaration of Conformity can be found at Emerson.com/Rosemount.

B.2 Ordinary Location Certification

As standard, the transmitter has been examined and tested to determine that the design meets the basic electrical, mechanical, and fire protection requirements by a nationally recognized test laboratory (NRTL) as accredited by the Federal Occupational Safety and Health Administration (OSHA). Complies with FM 3810:2005 and CSA: C22.2 No. 1010.1.

B.3 Telecommunication compliance

B.3.1 FCC

This device complies with Part 15C of the FCC Rules. Operation is subject to the following two conditions: (1) This device may not cause interference, and (2) this device must accept any interference received, including interference that may cause undesired operation.

Certificate: K8C5900

B.3.2 IC

This device complies with RSS210-7.

Certificate: 2827A-5900

B.3.3 Radio Equipment Directive (RED)

This device complies with ETSI EN 302 372 and EN 62479. EU directive 2014/53/EU. The device shall be installed according to requirements ETSI EN 302372.

B.4 CE-mark

The product complies with applicable EU directives (EMC, ATEX, LVD, and RED). Based on the low emitted effects from the gauges (below 0.1 mW) compared to limits given by the Rec. 1999/519/EC, no additional measures are needed.

B.5 Installing Equipment in North America

The US National Electrical Code® (NEC) and the Canadian Electrical Code (CEC) permit the use of Division marked equipment in Zones and Zone marked equipment in Divisions.

The markings must be suitable for the area classification, gas, and temperature class. This information is clearly defined in the respective codes.

B.6 North America

B.6.1 I5 USA Intrinsic Safety

Certificate	FM 17US0030X
Standards	FM Class 3600:2018, FM Class 3610:2018, FM Class 3810:2005, ANSI/ISA 61010-1:2004, ANSI/NEMA 250:2003, ANSI/IEC 60529:2004, ANSI/UL 60079-0:2013 Ed 6, ANSI/UL 60079-11:2014 Ed 6.3, ANSI/UL 60079-26:2017 Ed 3
Markings	IS/I,II,III/1/ABCDEFG/T4 DIP/II,III/1/EFG/T5 CL 1 ZN 0 AEx ia IIC T4 Ga CL 1 ZN 0/1 AEx ib IIC T4 Ga/Gb Ta = -50°C to 80°C - 9240040-917; Type 4X; IP66; IP67

	Ui (Vmax)	Ii (I _{max})	Pi	Ci	Li
Entity parameters	30 V	300 mA	1.3 W	1.1 nF	1.5 μH
FISCO parameters	17.5V	380 mA	5.32 W	1.1 nF	1.5 μH

Specific Conditions for Safe Use (X):

1. The enclosure contains aluminum and is considered to present a potential risk of ignition by impact or friction. When installed as EPL Ga, care must be taken during installation and use to prevent impact or friction.
2. Non-metallic surfaces and the surface of the painted housing may, under certain extreme conditions, generate an ignition-capable level of electrostatic. Appropriate measures must be taken to prevent electrostatic discharge.
3. Using the box provided on the nameplate, the User shall permanently mark the type of protection chosen for the specific installation. Once the type of protection has been marked it shall not be changed.
4. When installed as Ex ib Ga/Gb, the partition wall materials separating EPL Ga from EPL Gb are constructed of different materials depending on the antenna option. Please refer to Control Drawing D9240040-917 for the material type of each antenna. The material shall not be subject to environmental conditions which might adversely affect the partition wall.

5. Maximum Process Temperatures are as follows:

When option n=Tank Seal	O-ring Type	Min/Max Process Temperature Range
PV or QV	Viton	-15°C to +180°C
PK, FK, HK or QK	Kalrez	-20°C to +230°C
PE or QE	EPDM	-40°C to +110°C
PB or QB	BUNA-N	-35°C to +90°C
PM, FF, HH or QM	FVMQ	-60°C to +155°C
PF or QF	FEP	-60°C to +180°C

B.6.2 I6 Canada Intrinsic Safety

Certificate	FM17CA0016X
Standards	CSA-C22.2 No. 25-2017 CSA-C22.2 No. 94-M91:1991 (R2011) CSA-C22.2 No. 1010-1:2004 (R2009) CSA-C22.2 No. 60529:2016 CSA-C22.2 No. 60079-0:2015 CSA-C22.2 No. 60079-11:2014 CSA-C22.2 No. 60079-26:2016
Markings	IS/I,II,III/1/ABCDEFG/T4 Ex ia IIC T4 Ga Ex ib IIC T4 Ga/Gb DIP/II,III/1/EFG/T5 Ta = -50°C to 80°C 9240040-917 Type 4X; IP66; IP67

	Ui (Vmax)	Ii (Imax)	Pi	Ci	Li
Entity parameters	30 V	300 mA	1.3 W	1.1 nF	1.5 μH
FISCO parameters	17.5V	380 mA	5.32 W	1.1 nF	1.5 μH

Specific Conditions for Safe Use (X):

1. The enclosure contains aluminum and is considered to present a potential risk of ignition by impact or friction. When installed as EPL Ga, care must be taken during installation and use to prevent impact or friction.
2. Non-metallic surfaces and the surface of the painted housing may, under certain extreme conditions, generate an ignition-capable level of electrostatic. Appropriate measures must be taken to prevent electrostatic discharge.

3. Using the box provided on the nameplate, the User shall permanently mark the type of protection chosen for the specific installation. Once the type of protection has been marked it shall not be changed.
4. When installed as Ex ib Ga/Gb, the partition wall materials separating EPL Ga from EPL Gb are constructed of different materials depending on the antenna option. Please refer to Control Drawing D9240040-917 for the material type of each antenna. The material shall not be subject to environmental conditions which might adversely affect the partition wall.
5. Maximum Process Temperatures are as follows:

When option n= Tank Seal	O-ring Type	Min/Max Process Temperature Range
PV or QV	Viton	-15°C to +180°C
PK, FK, HK or QK	Kalrez	-20°C to +230°C
PE or QE	EPDM	-40°C to +110°C
PB or QB	BUNA-N	-35°C to +90°C
PM, FF, HH or QM	FVMQ	-60°C to +155°C
PF or QF	FEP	-60°C to +180°C

B.7 Europe

B.7.1 I1 ATEX Intrinsic Safety

Certificate	FM09ATEX0057X
Standards	EN IEC 60079-0:2018, EN 60079-11:2012, EN 60079-26:2015, EN 60529:1991+A1(2000)+A2(2013)
Markings	 II 1 G Ex ia IIC T4 Ga II 1/2 G Ex ib IIC T4 Ga/Gb Ta = -50°C to 80°C; IP66, IP67

	Ui (Vmax)	Ii (Imax)	Pi	Ci	Li
Entity parameters	30 V	300 mA	1.3 W	1.1 nF	1.5 μH
FISCO parameters	17.5V	380 mA	5.32 W	1.1 nF	1.5 μH

Specific Conditions for Safe Use (X):

1. The enclosure contains aluminum and is considered to present a potential risk of ignition by impact or friction. When installed as EPL Ga, care must be taken during installation and use to prevent impact or friction.

2. Non-metallic surfaces and the surface of the painted housing may, under certain extreme conditions, generate an ignition-capable level of electrostatic. Appropriate measures must be taken to prevent electrostatic discharge.
3. Using the box provided on the nameplate, the User shall permanently mark the type of protection chosen for the specific installation. Once the type of protection has been marked it shall not be changed.
4. When installed as Ex ib Ga/Gb, the partition wall materials separating EPL Ga from EPL Gb are constructed of different materials depending on the antenna option. Please refer to Control Drawing D9240040-917 for the material type of each antenna. The material shall not be subject to environmental conditions which might adversely affect the partition wall.
5. Maximum Process Temperatures are as follows:

When option n=Tank Seal	O-ring Type	Min/Max Process Temperature Range
PV or QV	Viton	-15°C to +180°C
PK, FK, HK or QK	Kalrez	-20°C to +230°C
PE or QE	EPDM	-40°C to +110°C
PB or QB	BUNA-N	-35°C to +90°C
PM, FF, HH or QM	FVMQ	-60°C to +155°C
PF or QF	FEP	-60°C to +180°C

B.8 International

B.8.1 I7 IECEx Intrinsic Safety

Certificate	IECEx FMG 09.0009X
Standards	IEC 60079-0:2017, IEC 60079-11:2011, IEC 60079-26:2014
Markings	Ex ia IIC T4 Ga Ex ib IIC T4 Ga/Gb Ta = -50°C to +80°C; IP66, IP67

	Ui (Vmax)	Ii (Imax)	Pi	Ci	Li
Entity parameters	30 V	300 mA	1.3 W	1.1 nF	1.5 μH
FISCO parameters	17.5V	380 mA	5.32 W	1.1 nF	1.5 μH

Specific Conditions for Safe Use (X):

1. The enclosure contains aluminum and is considered to present a potential risk of ignition by impact or friction. When installed as EPL Ga, care must be taken during installation and use to prevent impact or friction.

2. Non-metallic surfaces and the surface of the painted housing may, under certain extreme conditions, generate an ignition-capable level of electrostatic. Appropriate measures must be taken to prevent electrostatic discharge.
3. Using the box provided on the nameplate, the User shall permanently mark the type of protection chosen for the specific installation. Once the type of protection has been marked it shall not be changed.
4. When installed as Ex ib Ga/Gb, the partition wall materials separating EPL Ga from EPL Gb are constructed of different materials depending on the antenna option. Please refer to Control Drawing D9240040-917 for the material type of each antenna. The material shall not be subject to environmental conditions which might adversely affect the partition wall.
5. Maximum Process Temperatures are as follows:

When option n= Tank Seal	O-ring Type	Min/Max Process Temperature Range
PV or QV	Viton	-15°C to +180°C
PK, FK, HK or QK	Kalrez	-20°C to +230°C
PE or QE	EPDM	-40°C to +110°C
PB or QB	BUNA-N	-35°C to +90°C
PM, FF, HH or QM	FVMQ	-60°C to +155°C
PF or QF	FEP	-60°C to +180°C

B.9 Brazil

B.9.1 I2 INMETRO Intrinsic Safety

Certificate UL-BR 17.0982X

Standards ABNT NBR IEC 60079-0:2013, 60079-11:2013, 60079-26:2016

Markings Ex ia IIC T4 Ga/Gb
Tamb: -50 °C to + 80 °C
IP66/IP67

	Ui (Vmax)	Ii (Imax)	Pi	Ci	Li
Entity parameters	30 V	300 mA	1.3 W	1.1 nF	1.5 μH
FISCO parameters	17.5V	380 mA	5.32 W	1.1 nF	1.5 μH

Special Conditions for Safe Use (X):

1. See certificate for special conditions.

B.10 China

B.10.1 I3 China Intrinsic Safety

Certificate GYJ16.1251X
Standards GB 3836.1 - 2010, GB 3836.4 - 2010, GB 3836.20 - 2010
Markings Ex ia IIC T4 Ga

	Ui (Vmax)	Ii (Imax)	Pi	Ci	Li
Entity parameters	30 V	300 mA	1.3 W	1.1 nF	1.5 μH
FISCO parameters	17.5V	380 mA	5.32 W	1.1 nF	1.5 μH

Special Conditions for Safe Use (X):

1. See certificate for special conditions.

B.11 Technical Regulations Customs Union (EAC)

B.11.1 IM EAC Intrinsic Safety

Certificate RU C-SE.AA87.B.00346
Markings Ga/Gb Ex ia IIC T4 X
 Tamb: -50 °C to + 80 °C
 IP66/IP67

	Ui (Vmax)	Ii (Imax)	Pi	Ci	Li
Entity parameters	30 V	300 mA	1.3 W	1.1 nF	1.5 μH
FISCO parameters	17.5V	380 mA	5.32 W	1.1 nF	1.5 μH

Special Conditions for Safe Use (X):

1. See certificate for special conditions.

B.12 Japan

B.12.1 I4 Japan Intrinsic Safety

Certificate CML 17JPN2301X
Markings Ex ia IIC T4 Ga/Gb
 $-50\text{ °C} \leq T_a \leq +80\text{ °C}$

	Ui (Vmax)	Ii (Imax)	Pi	Ci	Li
Entity parameters	30 V	300 mA	1.3 W	1.1 nF	1.5 μH
FISCO parameters	17.5V	380 mA	5.32 W	1.1 nF	1.5 μH

Special Conditions for Safe Use (X):

1. See certificate for special conditions.

B.13 Republic of Korea

B.13.1 IP Korea Intrinsic Safety

Certificate 14-KB4BO-0573X
Markings Ex ia IIC T4 Ga/Gb
 (-50 °C ≤ Ta ≤ +80 °C)

	Ui (Vmax)	Ii (Imax)	Pi	Ci	Li
Entity parameters	30 V	300 mA	1.3 W	1.1 nF	1.5 μH
FISCO parameters	17.5V	380 mA	5.32 W	1.1 nF	1.5 μH

Special Conditions for Safe Use (X):

1. See certificate for special conditions.

B.14 Additional Certifications

B.14.1 Functional Safety Certification (SIS)

3 Functional Safety

Certificate ROS 1312032 C001
 SIL 3 2-in-1 (1oo2) option (SIS-relays)
Standards IEC 61508:2010 Parts 1-7

S Functional Safety

Certificate ROS 1312032 C004
 SIL 2 1-in-1 (1oo1) option, with 4-20mA or K1/K2 relay
Standards IEC 61508:2010 Parts 1-7
Certificate ROS 1312032 C005
 SIL 2 2-in-1 (1oo1) option, with 4-20mA or K1/K2 relay
Standards IEC 61508:2010 Parts 1-7

B.14.2 Germany WHG Certification (DIBt)

Certificate Z-65.16-500

B.14.3 Belgium Overfill Certification (Vlarem)

Certificate 99/H031/13072201

B.14.4 India Intrinsic Safety

Certificate P349859/1

Markings Ex ia IIC Ga/Gb

B.15 Custody Transfer Certifications

Australia Custody Transfer

Certificate No 5/1/7

Standards Regulation 60: National Measurement Regulations 1999

Belgium Custody Transfer

BMS NR. P6.0.014.02-B-16

Certificate

Bulgaria Custody Transfer

Bulgaria Institute of Metrology 18.10.5106.1

China Custody Transfer

CPA Pattern Approval

Certificate 2012-L134

Croatia Custody Transfer

Certificate 558-02-01_01-15-2

Czech Republic Custody Transfer

Certificate 0111-CS-C022-10

Estonia Custody Transfer

Certificate TJA 6.13-3_15.09.11

France Custody Transfer

Certificate No. LNE-24609

Germany Custody Transfer

Certificate PTB-1.5-4058175

India Custody Transfer

Certificate IND/13/12/191

Indonesia Custody Transfer

Certificate DITJEN MIGAS CT approval 26.10.2010

Italy Custody Transfer

Certificate 183349 (Raptor system)

Kazakhstan Custody Transfer

GOST Pattern Approval:

Certificate KZ.02.02.06177-2018 No.14983 (5900)
KZ.02.02.04018-2014 No.10790 (System)

Malaysia Custody Transfer

Certificate ATS 09-11

Netherlands Custody Transfer

NMI TC7982
Certificate

Norway Custody Transfer

Certificate No. N-11-7146

Poland Custody Transfer

Certificate ZT-7 2013

Portugal Custody Transfer

Certificate P12_101.12_31

Russia Custody Transfer

GOST Pattern Approval:

Certificate SE.C.29.639.A No. 66902 (5900)

Serbia Custody Transfer

Certificate 393-7_0-01-2088

South Africa Custody Transfer

Certificate SAEx S11-065

Switzerland Custody Transfer

Certificate Zulassungszertifikat CH-L-11127-01

OIML Custody Transfer

Certificate R85-2008-SE-11.01

B.16 Product Certifications Rosemount 2051

Extract from Rosemount 2051 Product Certifications Rev: 1.13

B.16.1 North America

IE USA FISCO

Certificate FM16US0231X

Standards FM Class 3600 – 2011, FM Class 3610 – 2010, FM Class 3611 – 2004, FM Class 3810 – 2005

Markings IS CLI, DIV 1, GP A, B, C, D when connected per Rosemount drawing 02051-1009 ($-50^{\circ}\text{C} \leq T_a \leq +60^{\circ}\text{C}$); Type 4x

Special Conditions for Safe Use (X):

1. The Model 2051 transmitter housing contains aluminum and is considered a potential risk of ignition by impact or friction. Care must be taken into account during installation and use to prevent impact and friction.

IF Canada Intrinsic Safety

Certificate 2041384

Standards CSA Std. C22.2 No. 142 - M1987, CSA Std. C22.2 No. 213 - M1987, CSA Std. C22.2 No. 157 - 92, ANSI/ISA 12.27.01 – 2003, CAN/CSA-E60079-0:07, CAN/CSA-E60079-11:02

Markings Intrinsically safe for Class I, Division 1, Groups A, B, C, and D when connected in accordance with Rosemount drawing 02051-1008. Ex ia IIC T3C. Single Seal. Enclosure Type 4X

B.16.2 Europe

IA ATEX FISCO

Certificate Baseefa08ATEX0129X
Standards EN60079-0:2012+A11:2013, EN60079-11:2012
Markings  II 1 G Ex ia IIC T4 Ga (-60°C ≤ Ta ≤ +60°C)

	Ui	Ii	Pi	Ci	Li
FISCO parameters	17.5V	380 mA	5.32 W	0 μF	0 mH

Special Conditions for Safe Use (X):

1. If the equipment is fitted with an optional 90V transient suppressor, it is incapable of withstanding the 500V isolation from earth test and this must be taken into account during installation.
2. The enclosure may be made of aluminum alloy and given a protective polyurethane paint finish; however care should be taken to protect it from impact and abrasion when located in Zone 0.

B.16.3 International

IG IECEx FISCO

Certificate IECExBAS08.0045X
Standards IEC60079-0:2011, IEC60079-11:2011
Markings Ex ia IIC T4 Ga (-60°C ≤ Ta ≤ +60°C)

	Ui	Ii	Pi	Ci	Li
FISCO parameters	17.5V	380 mA	5.32 W	0 nF	0 μH

Special Conditions for Safe Use (X):

1. If the equipment is fitted with an optional 90V transient suppressor, it is incapable of withstanding the 500V isolation from earth test and this must be taken into account during installation.
2. The enclosure may be made of aluminum alloy and given a protective polyurethane paint finish; however care should be taken to protect it from impact and abrasion when located in Zone 0.
3. The equipment contains thin wall diaphragms. The installation, maintenance and use shall take into account the environmental conditions to which the diaphragms will be subjected. The manufacturer's instructions for installation and maintenance shall be followed in detail to assure safety during its expected lifetime.

B.17 Approval Drawings

Follow the installation guidelines presented in Factory Mutual system control drawings in order to maintain certified ratings for installed devices.

The following drawing is included in the documentation for the Rosemount 5900S Radar Level Gauge:

9240040-917 System Control Drawing for hazardous location installation of intrinsically safe FM ATEX, FM IECEx, FM-US, and FM-C approved apparatus.

See the “Manuals & Drawings” CD ROM that is shipped with the Rosemount 5900S Radar Level Gauge for electronic copies of the system control drawings.

Drawings are also available on the Emerson web site www.Emerson.com.

C FOUNDATION™ Fieldbus Block Information

C.1 Resource block

This section contains information on the Resource Block of the Rosemount 5900S Radar Level Gauge.

The resource block defines the physical resources of the device. The resource block also handles functionality that is common across multiple blocks. The block has no linkable inputs or outputs.

Table C-1: Resource Block Parameters

Index Number	Parameter	Description
01	ST_REV	The revision level of the static data associated with the function block.
02	TAG_DESC	The user description of the intended application of the block.
03	STRATEGY	The strategy field can be used to identify grouping of blocks.
04	ALERT_KEY	The identification number of the plant unit.
05	MODE_BLK	The actual, target, permitted, and normal modes of the block: Target: The mode to “go to” Actual: The mode the “block is currently in” Permitted: Allowed modes that target may take on Normal: Most common mode for actual
06	BLOCK_ERR	This parameter reflects the error status associated with the hardware or software components associated with a block. It is a bit string, so that multiple errors may be shown.
07	RS_STATE	State of the function block application state machine.
08	TEST_RW	Read/write test parameter - used only for conformance testing.
09	DD_RESOURCE	String identifying the tag of the resource which contains the Device Description for this resource.
10	MANUFAC_ID	Manufacturer identification number – used by an interface device to locate the DD file for the resource.
11	DEV_TYPE	Manufacturer’s model number associated with the resource - used by interface devices to locate the DD file for the resource.
12	DEV_REV	Manufacturer revision number associated with the resource - used by an interface device to locate the DD file for the resource.

Table C-1: Resource Block Parameters (continued)

Index Number	Parameter	Description
13	DD_REV	Revision of the DD associated with the resource - used by an interface device to locate the DD file for the resource. The DD_REV specifies the minimum DD revision that is compatible with the device (within the same device revision). A vendor can release an updated DD with the DD_REVISION higher than the DD_REV. This allows a vendor to release an updated DD files set that will be compatible with an existing device revision in the field. The host can always load a higher DD_REVISION for a given DEV_REV/DEV_REVISION. As per Foundation requirement the DD_REV will always be 01.
14	GRANT_DENY	Options for controlling access of host computers and local control panels to operating, tuning, and alarm parameters of the block. Not used by device.
15	HARD_TYPES	The types of hardware available as channel numbers.
16	RESTART	Allows a manual restart to be initiated. Several degrees of restart are possible. They are the following: 1 Run – is the passive state of the parameter 2 Restart resource – not used 3 Restart with defaults – intended to reset parameters to default values, i.e. their value before any configuration was done 4 Restart processor – does a warm start of CPU
17	FEATURES	Used to show supported resource block options. The supported features are: <ul style="list-style-type: none"> • HARD_WRITE_LOCK_SUPPORT • SOFT_WRITE_LOCK_SUPPORT • REPORT_SUPPORT • UNICODE_SUPPORT • MULTI_BIT_ALARM • FAULT_STATE_SUPPORT
18	FEATURES_SEL	Used to select resource block options.
19	CYCLE_TYPE	Identifies the block execution methods available for this resource.
20	CYCLE_SEL	Used to select the block execution method for this resource. The Rosemount 5900S supports the following: Scheduled: Blocks are only executed based on the function block schedule. Block Execution: A block may be executed by linking to another blocks completion.
21	MIN_CYCLE_T	Time duration of the shortest cycle interval of which the resource is capable.
22	MEMORY_SIZE	Available configuration memory in the empty resource. To be checked before attempting a download.

Table C-1: Resource Block Parameters (continued)

Index Number	Parameter	Description
23	NV_CYCLE_T	Minimum time interval specified by the manufacturer for writing copies of NV parameters to non-volatile memory. Zero means it will never be automatically copied. At the end of NV_CYCLE_T, only those parameters which have changed need to be updated in NVRAM.
24	FREE_SPACE	Percent of memory available for further configuration. Zero in a pre-configured device.
25	FREE_TIME	Percent of the block processing time that is free to process additional blocks.
26	SHED_RCAS	Time duration at which to give up on computer writes to function block RCas locations. Shed from RCas shall never happen when SHED_ROUT = 0
27	SHED_ROUT	Time duration at which to give up on computer writes to function block ROut locations. Shed from ROut shall never happen when SHED_ROUT = 0
28	FAULT_STATE	Condition set by loss of communication to an output block, fault promoted to an output block or physical contact. When FAIL_SAFE condition is set, then output function blocks will perform their FAIL_SAFE actions.
29	SET_FSTATE	Allows the FAIL_SAFE condition to be manually initiated by selecting Set.
30	CLR_FSTATE	Writing a Clear to this parameter will clear the device FAIL_SAFE if the field condition has cleared.
31	MAX_NOTIFY	Maximum number of unconfirmed notify messages possible.
32	LIM_NOTIFY	Maximum number of unconfirmed alert notify messages allowed.
33	CONFIRM_TIME	The time the resource will wait for confirmation of receipt of a report before trying again. Retry will not happen when CONFIRM_TIME=0.
34	WRITE_LOCK	When hardware write protection is selected, WRITE_LOCK becomes an indicator of the jumper setting and is unavailable for software write protection. When software write lock is selected, and WRITE_LOCK is set, no writings from anywhere else are allowed, except to clear WRITE_LOCK. Block input will continue to be updated.
35	UPDATE_EVT	This alert is generated by any change to the static data.
36	BLOCK_ALM	The block alarm is used for all configuration, hardware, connection failure or system problems in the block. The cause of the alarm is entered in the subcode field. The first alarm to become active will set the Active status in the Status parameter. As soon as the Unreported status is cleared by the alarm reporting task, another block alarm may be reported without clearing the Active status, if the subcode has changed.
37	ALARM_SUM	The current alarm status, unacknowledged states, unreported states, and disabled states of the alarms associated with the function block.
38	ACK_OPTION	Selection of whether alarms associated with the function block will be automatically acknowledged.

Table C-1: Resource Block Parameters (continued)

Index Number	Parameter	Description
39	WRITE_PRI	Priority of the alarm generated by clearing the write lock.
40	WRITE_ALM	This alert is generated if the write lock parameter is cleared.
41	ITK_VER	Major revision number of the inter operability test case used in certifying this device as interoperable. The format and range are controlled by the Fieldbus Foundation.
42	FD_VER	A parameter equal to the value of the major version of the Field Diagnostics specification that this device was designed to.
43	FD_FAIL_ACTIVE	This parameter reflects the error conditions that are being detected as active as selected for this category. It is a bit string, so that multiple conditions may be shown.
44	FD_OFFSPEC_ACTIVE	
45	FD_MAINT_ACTIVE	
46	FD_CHECK_ACTIVE	
47	FD_FAIL_MAP	This parameter maps conditions to be detected as active for this alarm category. Thus the same condition may be active in all, some, or none of the 4 alarm categories.
48	FD_OFFSPEC_MAP	
49	FD_MAINT_MAP	
50	FD_CHECK_MAP	
51	FD_FAIL_MASK	This parameter allows the user to suppress any single or multiple conditions that are active, in this category, from being broadcast to the host through the alarm parameter. A bit equal to '1' will mask i.e. inhibit the broadcast of a condition, and a bit equal to '0' will unmask i.e. allow broadcast of a condition.
52	FD_OFFSPEC_MASK	
53	FD_MAINT_MASK	
54	FD_CHECK_MASK	
55	FD_FAIL_ALM	This parameter is used primarily to broadcast a change in the associated active conditions, which are not masked, for this alarm category to a Host System.
56	FD_OFFSPEC_ALM	
57	FD_MAINT_ALM	
58	FD_CHECK_ALM	
59	FD_FAIL_PRI	This parameter allows the user to specify the priority of this alarm category.
60	FD_OFFSPEC_PRI	
61	FD_MAINT_PRI	
62	FD_CHECK_PRI	
63	FD_SIMULATE	This parameter allows the conditions to be manually supplied when simulation is enabled. When simulation is disabled both the diagnostic simulate value and the diagnostic value tracks the actual conditions. The simulate jumper is required for simulation to be enabled and while simulation is enabled the recommended action will show that simulation is active. Elements: see Table C-2 .

Table C-1: Resource Block Parameters (continued)

Index Number	Parameter	Description
64	FD_RECOMMEN_ACT	This parameter is a device enumerated summarization of the most severe condition or conditions detected. The DD help should describe by enumerated action, what should be done to alleviate the condition or conditions. 0 is defined as Not Initialized, 1 is defined as No Action Required, all others defined by manufacturer.
65	FD_EXTENDED_ACTIVE	An optional parameter or parameters to allow the user finer detail on conditions causing an active condition in the FD_*_ACTIVE parameters.
66	FD_EXTENDED_MAP	An optional parameter or parameters to allow the user finer control on enabling conditions contributing to the conditions in FD_*_ACTIVE parameters.
67	COMPATIBILITY_REV	This parameter is used when replacing field devices. The correct value of this parameter is the DEV_REV value of the replaced device.
68	HARDWARE_REVISION	Hardware revision.
69	SOFTWARE_REV	Software revision of source code with resource block.
70	PD_TAG	PD tag description of device.
71	DEV_STRING	This is used to load new licensing into the device. The value can be written but will always read back with a value of 0.
72	DEV_OPTIONS	Indicates which miscellaneous device licensing options are enabled.
73	OUTPUT_BOARD_SN	Output board serial number. For the Rosemount 5900S this is the same as Main Label Device ID which can be found on the main label that is attached to the housing.
74	FINAL_ASSY_NUM	Final assembly number given by manufacturer.
75	DOWNLOAD_MODE	Gives access to the boot block code for over-the-wire downloads. 0 = Uninitialized 1 = Run mode 2 = Download mode
76	HEALTH_INDEX	Parameter representing the overall health of the device, 100 being perfect and 1 being non-functioning. The value is based on the active PWA alarms.
77	FAILED_PRI	Designates the alarming priority of the FAILED_ALM and also used as switch b/w FD and legacy PWA. If value is greater than or equal to 1 then PWA alerts will be active in device else device will have FD alerts.
78	RECOMMENDED_ACTION	Enumerated list of recommended actions displayed with a device alert.
79	FAILED_ALM	Alarm indicating a failure within a device which makes the device non-operational.
80	MAINT_ALM	Alarm indicating the device needs maintenance soon. If the condition is ignored, the device will eventually fail.
81	ADVISE_ALM	Alarm indicating advisory alarms. These conditions do not have a direct impact on the process or device integrity.

Table C-1: Resource Block Parameters (continued)

Index Number	Parameter	Description
82	FAILED_ENABLE	Enabled FAILED_ALM alarm conditions. Corresponds bit for bit to the FAILED_ACTIVE. A bit on means that the corresponding alarm condition is enabled and will be detected. A bit off means the corresponding alarm condition is disabled and will not be detected. This parameter is the Read Only copy of FD_FAIL_MAP.
83	FAILED_MASK	Mask of FAILED_ALM. Corresponds bit of bit to FAILED_ACTIVE. A bit on means that the condition is masked out from alarming. This parameter is the Read Only copy of FD_FAIL_MASK.
84	FAILED_ACTIVE	Enumerated list of failure conditions within a device. All open bits are free to be used as appropriate for each specific device. This parameter is the Read Only copy of FD_FAIL_ACTIVE.
85	MAINT_PRI	Designates the alarming priority of the MAINT_ALM
86	MAINT_ENABLE	Enabled MAINT_ALM alarm conditions. Corresponds bit for bit to the MAINT_ACTIVE. A bit on means that the corresponding alarm condition is enabled and will be detected. A bit off means the corresponding alarm condition is disabled and will not be detected. This parameter is the Read Only copy of FD_OFFSPEC_MAP
87	MAINT_MASK	Mask of MAINT_ALM. Corresponds bit of bit to MAINT_ACTIVE. A bit on means that the condition is masked out from alarming. This parameter is the Read Only copy of FD_OFFSPEC_MASK.
88	MAINT_ACTIVE	Enumerated list of maintenance conditions within a device. This parameter is the Read Only copy of FD_OFFSPEC_ACTIVE.
89	ADVISE_PRI	Designates the alarming priority of the ADVISE_ALM
90	ADVISE_ENABLE	Enabled ADVISE_ALM alarm conditions. Corresponds bit for bit to the ADVISE_ACTIVE. A bit on means that the corresponding alarm condition is enabled and will be detected. A bit off means the corresponding alarm condition is disabled and will not be detected. This parameter is the Read Only copy of FD_MAINT_MASK & FD_CHECK_MASK.
91	ADVISE_MASK	Mask of ADVISE_ALM. Corresponds bit by bit to ADVISE_ACTIVE. A bit on means that the condition is masked out from alarming. This parameter is the Read Only copy of FD_MAINT_MASK & FD_CHECK_MASK.
92	ADVISE_ACTIVE	Enumerated list of advisory conditions within a device. All open bits are free to be used as appropriate for each specific device. This parameter is the Read Only copy of FD_MAINT_ACTIVE & FD_CHECK_ACTIVE.

Table C-2: FD_SIMULATE elements

Index	Parameter	Data Type	Size	Description
1	Diagnostic Simulate Value	Bit string	4	Writable. Used for diagnostics when simulation is enabled
2	Diagnostic Value	Bit string	4	Current diagnostics detected by the device.
3	Enable	Unsigned 8	1	Enable/Disable simulation. Dynamic, so simulation will always be disabled after a device restart.

C.2 Analog Input block

Figure C-1: Analog-Input Block

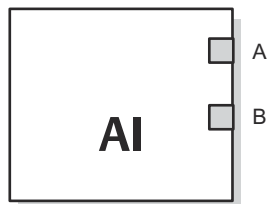

- A. *OUT_D = Discrete output that signals a selected alarm condition*
- B. *OUT = The block output value and status*

The Analog Input (AI) function block processes field device measurements and makes them available to other function blocks. The output value from the AI block is in engineering units and contains a status indicating the quality of the measurement. The measuring device may have several measurements or derived values available in different channels. Use the channel number to define the variable that the AI block processes.

The AI block supports alarming, signal scaling, signal filtering, signal status calculation, mode control, and simulation. In Automatic mode, the block's output parameter (OUT) reflects the process variable (PV) value and status. In Manual mode, OUT may be set manually. The Manual mode is reflected on the output status. A discrete output (OUT_D) is provided to indicate whether a selected alarm condition is active. Alarm detection is based on the OUT value and user specified alarm limits.

[Table C-3](#) lists the AI block parameters and their units of measure, descriptions, and index numbers.

Figure C-2: Analog Input Function Block Schematic

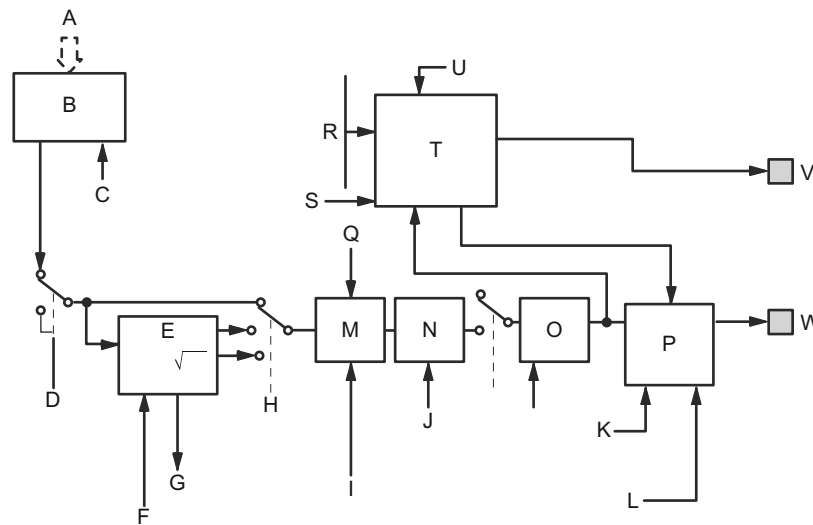

- A. Analog Measurement
- B. Access Analog Measurement
- C. CHANNEL
- D. SIMULATE
- E. Convert
- F. OUT_SCALE; XD_SCALE
- G. FIELD_VAL
- H. L_TYPE
- I. IO_OPTS
- J. PV_FTIME
- K. MODE
- L. STATUS_OPTS
- M. Cutoff
- N. Filter
- O. PV
- P. Status Calc.
- Q. LOW_CUT
- R. HI_HI_LIM; HI_LIM; LO_LO_LIM; LO_LIM
- S. ALARM_HYS
- T. Alarm Detection
- U. ALARM_TYPE
- V. OUT_D = discrete output that signals a selected alarm condition
- W. OUT = block output value and status

Table C-3: Definitions of Analog Input Function Block System Parameters

Index Number	Parameter	Units	Description
01	ST_REV	None	The revision level of the static data associated with the function block. The revision value will be incremented each time a static parameter value in the block is changed.
02	TAG_DESC	None	The user description of the intended application of the block.
03	STRATEGY	None	The strategy field can be used to identify grouping of blocks. This data is not checked or processed by the block.
04	ALERT_KEY	None	The identification number of the plant unit. This information may be used in the host for sorting alarms, etc.
05	MODE_BLK	None	The actual, target, permitted, and normal modes of the block. Target: The mode to “go to” Actual: The mode the “block is currently in” Permitted: Allowed modes that target may take on Normal: Most common mode for target
06	BLOCK_ERR	None	This parameter reflects the error status associated with the hardware or software components associated with a block. It is a bit string, so that multiple errors may be shown.
07	PV	EU of XD_SCALE	The process variable used in block execution.
08	OUT	EU of OUT_SCALE	The block output value and status.
09	SIMULATE	None	A group of data that contains the current transducer value and status, the simulated transducer value and status, and the enable/disable bit.
10	XD_SCALE	None	The high and low scale values, engineering units code, and number of digits to the right of the decimal point associated with the channel input value.
11	OUT_SCALE	None	The high and low scale values, engineering units code, and number of digits to the right of the decimal point associated with OUT.
12	GRANT_DENY	None	Options for controlling access of host computers and local control panels to operating, tuning, and alarm parameters of the block. Not used by device.
13	IO_OPTS	None	Allows the selection of input/output options used to alter the PV. Low cutoff enabled is the only selectable option.
14	STATUS_OPTS	None	Allows you to select option for status handling and processing.
15	CHANNEL	None	The CHANNEL value is used to select the measurement value. You must configure the CHANNEL parameter before you can configure the XD_SCALE parameter.
16	L_TYPE	None	Linearization type. Determines whether the field value is used directly (Direct) or is converted linearly (Indirect).
17	LOW_CUT	%	If percentage value of transducer input fails below this, PV = 0.
18	PV_FTIME	Seconds	The time constant of the first-order PV filter. It is the time required for a 63 percent change in the IN value.

Table C-3: Definitions of Analog Input Function Block System Parameters (continued)

Index Number	Parameter	Units	Description
19	FIELD_VAL	Percent	The value and status from the transducer block or from the simulated input when simulation is enabled.
20	UPDATE_EVT	None	This alert is generated by any change to the static data.
21	BLOCK_ALM	None	The block alarm is used for all configuration, hardware, connection failure or system problems in the block. The cause of the alert is entered in the subcode field. The first alert to become active will set the Active status in the Status parameter. As soon as the Unreported status is cleared by the alert reporting task, another block alert may be reported without clearing the Active status, if the subcode has changed.
22	ALARM_SUM	None	The summary alarm is used for all process alarms in the block. The cause of the alert is entered in the subcode field. The first alert to become active will set the Active status in the Status parameter. As soon as the Unreported status is cleared by the alert reporting task, another block alert may be reported without clearing the Active status, if the subcode has changed.
23	ACK_OPTION	None	Used to set auto acknowledgment of alarms.
24	ALARM_HYS	Percent	The amount the alarm value must return within the alarm limit before the associated active alarm condition clears.
25	HI_HI_PRI	None	The priority of the HI HI alarm.
26	HI_HI_LIM	EU of PV_SCALE	The setting for the alarm limit used to detect the HI HI alarm condition.
27	HI_PRI	None	The priority of the HI alarm.
28	HI_LIM	EU of PV_SCALE	The setting for the alarm limit used to detect the HI alarm condition.
29	LO_PRI	None	The priority of the LO alarm.
30	LO_LIM	EU of PV_SCALE	The setting for the alarm limit used to detect the LO alarm condition.
31	LO_LO_PRI	None	The priority of the LO LO alarm.
32	LO_LO_LIM	EU of PV_SCALE	The setting for the alarm limit used to detect the LO LO alarm condition.
33	HI_HI_ALM	None	The HI HI alarm data, which includes a value of the alarm, a timestamp of occurrence and the state of the alarm.
34	HI_ALM	None	The HI alarm data, which includes a value of the alarm, a timestamp of occurrence and the state of the alarm.
35	LO_ALM	None	The LO alarm data, which includes a value of the alarm, a timestamp of occurrence and the state of the alarm.
36	LO_LO_ALM	None	The LO LO alarm data, which includes a value of the alarm, a timestamp of occurrence and the state of the alarm.
37	OUT_D	None	Discrete output to indicate a selected alarm condition.

Table C-3: Definitions of Analog Input Function Block System Parameters (continued)

Index Number	Parameter	Units	Description
38	ALARM_SEL	None	Used to select the process alarm conditions that will cause the OUT_D parameter to be set.
39	STDDEV	Percent	The average absolute error between the PV and its previous mean value over that evaluation time defined by VAR_SCAN.
40	CAP_STDDEV	Seconds	The time over which the VAR_INDEX is evaluated.

C.2.1 Simulation

To perform lab test of process variables and alerts, you can either change the mode of the AI block to manual and adjust the output value, or you can enable simulation through the configuration tool and manually enter a value for the measurement value and its status. In both cases, you must first set the SIMULATE switch (1) on the field device to the ON position, see [Simulation](#).

With simulation enabled, the actual measurement value has no impact on the OUT value or the status.

C.3 Analog Output block

Figure C-3: Analog-Output Block

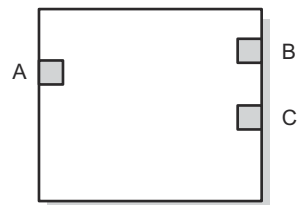

- A. CAS_IN = The remote setpoint value from another function block
- B. BKCAL_OUT = The value and status required by the BKCAL_IN input of another block to prevent reset windup and to provide bumpless transfer to closed loop control.
- C. OUT = The block output value and status

The Analog Output (AO) function block assigns an output value to a field device through a specified I/O channel. The block supports mode control, signal status calculation, and simulation. [Table C-4](#) lists the definitions of the system parameters. See also [Analog Output block](#).

Table C-4: Analog Output Function Block System Parameters

Parameter	Units	Description
BKCAL_OUT	EU of PV_SCALE	The value and status required by the BKCAL_IN input of another block to prevent reset windup and to provide bumpless transfer to closed loop control.

Table C-4: Analog Output Function Block System Parameters (continued)

Parameter	Units	Description
BLOCK_ERR	None	The summary of active error conditions associated with the block. The block errors for the AnalogOutput block are Simulate Active, Input Failure/Process Variable has Bad Status, Output Failure, Read back Failed, and Out of Service..
CAS_IN	EU of PV_SCALE	The remote setpoint value from another function block.
IO_OPTS	None	Allows you to select how the I/O signals are processed. The supported I/O options for the AO function block are SP_PV Track in Man, Increase to Close, and Use PV for BKCAL_OUT.
CHANNEL	None	Defines the output that drives the field device. See Analog Output block .
MODE	None	Enumerated attribute used to request and show the source of the setpoint and/or output used by the block.
OUT	EU of XD_SCALE	The primary value and status calculated by the block in Auto mode. OUT may be set manually in Man mode.
PV	EU of PV_SCALE	The process variable used in block execution. This value is converted from READBACK to show the actuator position in the same units as the setpoint value.
PV_SCALE	None	The high and low scale values, the engineering units code, and the number of digits to the right of the decimal point associated with the PV.
READBACK	EU of XD_SCALE	The measured or implied actuator position associated with the OUT value.
SIMULATE	EU of XD_SCALE	Enables simulation and allows you to enter an input value and status.
SP	EU of PV_SCALE	The target block output value (setpoint).
SP_HI_LIM	EU of PV_SCALE	The highest setpoint value allowed.
SP_LO_LIM	EU of PV_SCALE	The lowest setpoint value allowed.
SP_RATE_DN	EU of PV_SCALE per second	Ramp rate for downward setpoint changes. When the ramp rate is set to zero, the setpoint is used immediately.
SP_RATE_UP	EU of PV_SCALE per second	Ramp rate for upward setpoint changes. When the ramp rate is set to zero, the setpoint is used immediately.
SP_WRK	EU of PV_SCALE	The working setpoint of the block. It is the result of setpoint rate-of-change limiting. The value is converted to percent to obtain the block's OUT value.

C.3.1 Setting the output

To set the output for the AO block, you must first set the mode to define the manner in which the block determines its setpoint. In Manual mode the value of the output attribute (OUT) must be set manually by the user, and is independent of the setpoint. In Automatic mode, OUT is set automatically based on the value specified by the setpoint (SP) in

engineering units and the I/O options attribute (IO_OPTS). In addition, you can limit the SP value and the rate at which a change in the SP is passed to OUT.

In Cascade mode, the cascade input connection (CAS_IN) is used to update the SP. The back calculation output (BKCAL_OUT) is wired to the back calculation input (BKCAL_IN) of the upstream block that provides CAS_IN. This provides bumpless transfer on mode changes and windup protection in the upstream block. The OUT attribute or an analog readback value, such as valve position, is shown by the process value (PV) attribute in engineering units.

To support testing, you can enable simulation, which allows you to manually set the channel feedback. There is no alarm detection in the AO function block.

To select the manner of processing the SP and the channel output value configure the setpoint limiting options, the tracking options, and the conversion and status calculations.

C.4 Measurement Transducer block

The Measurement Transducer block contains the actual measurement data, including a level and distance reading. The transducer block includes information about sensor type, engineering units, and all parameters needed to configure the transmitter.

Table C-5: Measurement Transducer Block Parameters

Index Number	Parameter	Description
1	ST_REV	The revision level of the static data associated with the function block. The revision value increments each time a static parameter value in the block is changed.
2	TAG_DESC	The user description of the intended application of the block.
3	STRATEGY	The strategy field can be used to identify grouping of blocks. This data is not checked or processed by the block.
4	ALERT_KEY	The identification number of the plant unit. This information may be used in the host for sorting alarms, etc.
5	MODE_BLK	The actual, target, permitted, and normal modes of the block. Target: The mode to “go to” Actual: The mode the “block is currently in” Permitted: Allowed modes that target may take on Normal: Most common mode for target
6	BLOCK_ERR	This parameter reflects the error status associated with the hardware or software components associated with a block. It is a bit string, so that multiple errors may be shown.
7	UPDATE_EVT	This alert is generated by any change to the static data

Table C-5: Measurement Transducer Block Parameters (continued)

Index Number	Parameter	Description
8	BLOCK_ALM	The block alarm is used for all configuration, hardware, connection failure or system problems in the block. The cause of the alert is entered in the subcode field. The first alert to become active will set the Active status in the Status parameter. As soon as the Unreported status is cleared by the alert reporting task, another block alert may be reported without clearing the Active status, if the subcode has changed.
9	TRANSDUCER_DIRECTORY	Directory that specifies the number and starting indices of the transducers in the transducer block.
10	TRANSDUCER_TYPE	Identifies the transducer.
11	TRANSDUCER_TYPE_VER	
12	XD_ERROR	A transducer block alarm subcode.
13	COLLECTION_DIRECTORY	A directory that specifies the number, starting indices, and DD Item ID's of the data collections in each transducer within a transducer block.
14	RADAR_LEVEL_TYPE	
15	HOUSING_TEMPERATURE	Internal temperature of the level gauge electronics
16	TEMPERATURE_UNIT	Measurement unit for temperature
17	LEVEL	Distance from the zero level (tank bottom) to the product surface
18	LENGTH_UNIT	Length Unit
19	LEVEL_RATE	Velocity at which the product surface is moving
20	LEVEL_RATE_UNIT	Level Rate Unit
21	ENV_DEVICE_MODE	Service Mode (see Table C-6)
22	DIAGN_DEVICE_ALERT	Errors and warnings for 2410 Tank Hub usage. See Table C-15 .
23	DEVICE_VERSION_NUMBER	PM card SW version number
24	DIAGN_REVISION	PM revision
25	SERIAL_NO	Main Label Device ID
26	STATS_ATTEMPTS	Total number of messages sent to PM
27	STATS_FAILURES	Total number of failed messages to PM
28	STATS_TIMEOUTS	Total number of timed-out messages to PM
29	FF_DEVICE_NUMBER	CM board serial number
30	FF_WRITE_PROTECT	CM board write protection status
31	P1451_SLAVE_STATS	Communication statistics
32	P1451_HOST_STATS	Communication statistics

Table C-5: Measurement Transducer Block Parameters (continued)

Index Number	Parameter	Description
33	DISTANCE	Distance from the tank reference point (normally the lower side of the flange) to the product surface
34	SIGNAL_STRENGTH	Amplitude of the echo from the product surface. A high value indicates a good reflection by the surface
35	SIGNAL_STRENGTH_UNI	Signal strength unit
36	ANTENNA_TYPE	Antenna type on the device (see Table C-7)
37	TCL	Tank Connection Length. Electrical distance between the transmitter's reference point and the microwave unit. Only for user defined antennas.
38	PIPE_DIAMETER	Still-pipe inner diameter, see Tank geometry .
39	HOLD_OFF_DIST	Hold Off Distance defines how close to the gauge's reference point a level measurement is accepted, see Tank geometry .
40	ANTENNA_SIZE	Still-pipe Array antenna size
41	OFFSET_DIST_G	Gauge Reference Distance (G), see Tank geometry . Use the Distance Offset (G) if a reference point other than the lower side of the device flange is required.
42	TANK_HEIGHT_R	Tank Reference Height (R) is defined as the distance between the upper reference point and the lower reference point (zero level). See Tank geometry .
43	BOTTOM_OFFSET_DIST_C	Minimum Level Offset (C) defines a lower null zone which extends the measurement range beyond the Zero Level Reference Point down to the tank bottom. See Tank geometry .
44	CALIBRATION_DIST	Calibration Distance is by default set to zero. It is used to adjust the level measurement so that measured levels match hand dipped levels. See Tank geometry .
45	TANK_SHAPE	Tank Type (see Tank shape and Table C-9). Optimizes the 5900S for various tank geometries.
46	TANK_BOTTOM_TYPE	Tank Bottom Type. Optimizes the Rosemount 5900S for measurements close to the tank bottom. See Table C-10 .
47	TANK_ENVIRONMENT	Tank Environment. See Environment . Mark the check boxes that correspond to the conditions in your tank. For best performance you should not choose more than two options. See Table C-11 .
48	TANK_PRESENTATION	Tank Presentation. See Table C-12 .
49	PRODUCT_DC	Product dielectric constant
50	ENV_WRITE_PROTECT	Write protect
51	RM_VERSION_NUMBER	RM card version number
52	DEVICE_MODEL	Device Model

Table C-5: Measurement Transducer Block Parameters (continued)

Index Number	Parameter	Description
53	TANK_EXPANSION_COEFF	Tank Expansion Coefficient
54	TANK_CALIB_AVG_TEMP	Tank Calibration Average Temperature
55	DAMPING_VALUE	Damping Value
56	HEART_BEAT_COUNT	This number should be incrementing. It is an indication that the device is alive.
57	DEVICE_STATUS	Device Status. See also Device status .
58	DEVICE_COMMAND	Command
59	VOLUME	Product volume in the tank. A value of 0 could indicate that the volume calculation is not enabled.
60	VOLUME_UNIT	Unit code for all volume parameters
61	MODEL_CODE	Model code
62	FF_SUPPORT_INFO	FF Support Information
63	FF_APPL_VERSION_NUMBER	CM version number
64	SENSOR_DIAGNOSTICS	Sensor Diagnostics
65	VAPOR_PRESSURE	Tank vapor pressure. Data provided from AO block.
66	VAPOR_TEMPERATURE	Tank vapor temperature. Data provided from AO block.
67	USER_DEFINED	User Defined value
68	TANK_TEMPERATURE	Tank Temperature
69	PRESSURE_UNIT	Pressure Unit
70	USED_HOLD_OFF	Used Hold Off Distance

Table C-6: Device Mode

VALUE	ENV_DEVICE_MODE
0	Normal operation
2	Restart device
3	Set device to factory default

Table C-7: Antenna Type

VALUE	ANTENNA_TYPE
5001	Still-Pipe Array Fixed
5002	Still-Pipe Array Hatch
3002	Parabolic
2001	Horn
6001	LPG/LNG 150 psi Valve

Table C-7: Antenna Type (continued)

VALUE	ANTENNA_TYPE
6002	LPG/LNG 150 psi
6011	LPG/LNG 300 psi Valve
6012	LPG/LNG 300 psi
6021	LPG/LNG 600 psi Valve
6022	LPG/LNG 600 psi
7041	Cone 4 in. PTFE
7042	Cone 4 in. Quartz
7061	Cone 6 in. PTFE
7062	Cone 6 in. Quartz
7081	Cone 8 in. PTFE
7082	Cone 8 in. Quartz
3001	Parabolic 2930
4001	Still-Pipe 2940/3940
4501	Still-Pipe 2945/3945
1000	User defined Free Propagation
1001	User defined Still-Pipe
1003	User defined Still-Pipe Array

Table C-8: Antenna Size

VALUE	ANTENNA_SIZE
0	Pipe 5 inch
1	Pipe 6 inch
2	Pipe 8 inch
3	Pipe 10 inch
4	Pipe 12 inch

Table C-9: Tank Shape

VALUE	TANK_SHAPE
0	Unknown
1	Vertical Cylinder
2	Horizontal Cylinder
3	Spherical
4	Cubical
5	Floating Roof

Table C-10: Tank Bottom Type

VALUE	TANK_BOTTOM_TYPE
0	Unknown
1	Flat
2	Dome
3	Cone
4	Flat Inclined

Table C-11: Environment

VALUE	TANK_ENVIRONMENT
2	Rapid Level Change (>0.1 m/s, >4 in/s)
8	Turbulent Surface
10	Foam
20	Solid Product

Table C-12: Tank Presentation

VALUE	TANK_PRESENTATION
0	
0x00000001	Level above min distance possible
0x00000002	Predicting allowed
0x00000004	Bottom echo always visible when tank is empty
0x00000008	Tank contains double bounces
0x00000010	Use slow search
0x00000020	Enable double surface function
0x00000040	Select lower surface
0x00000080	Reserved
0x00000100	Show negative level as zero
0x00000200	Use monotone level ullage presentation
0x00000400	Use bottom projection
0x00000800	Reserved
0x00001000	Invalid level is NOT set if tank is empty or full
0x00002000	Do not set invalid level when empty
0x00004000	Do not set invalid level when full
0x00008000	Reserved
0x00010000	Use extra echo function
0x00020000	Always track first echo

Table C-12: Tank Presentation (continued)

VALUE	TANK_PRESENTATION
0x00040000	Use harder level rate filtering around beams
0x00080000	Reserved

Table C-13: Product Dielectric Constant

VALUE	PRODUCT_DC
0	Unknown
1	Range (< 2.5)
2	Range (< 2.5 - 4)
3	Range (< 4 -10)
4	Range (>10)

Table C-14: Device Status

VALUE	DEVICE_STATUS
0x00000001	Reserved
0x00000002	Running Boot SW
0x00000004	Device Warning
0x00000100	Device Error
0x00000800	BOOT Beta version used
0x00001000	APPL Beta version used
0x00008000	Level correction error
0x00010000	Invalid measurement
0x00020000	Write protected
0x00040000	Default database
0x00800000	Simulation active
0x02000000	SIL Enabled
0x20000000	RM reprogramming in progress

C.4.1 Diagnostic device alerts

Table C-15 lists conditions reported in the DIAGN_DEVICE_ALERT parameter.

Table C-15: Device Alerts

Value	Description
	No alarm active
0x0008 0000	Database error
0x0010 0000	Hardware error

Table C-15: Device Alerts (continued)

Value	Description
0x0020 0000	Configuration error
0x0040 0000	Software error
0x1000 0000	Simulation Mode
0x2000 0000	Software write protected

C.5 Volume Transducer block

Table C-16: Volume Transducer Block Parameters

Index Number	Parameter	Description
1	ST_REV	The revision level of the static data associated with the function block. The revision value increments each time a static parameter value in the block is changed.
2	TAG_DESC	The user description of the intended application of the block.
3	STRATEGY	The strategy field can be used to identify grouping of blocks. This data is not checked or processed by the block.
4	ALERT_KEY	The identification number of the plant unit. This information may be used in the host for sorting alarms, etc.
5	MODE_BLK	The actual, target, permitted, and normal modes of the block. Target: The mode to “go to” Actual: The mode the “block is currently in” Permitted: Allowed modes that target may take on Normal: Most common mode for target
6	BLOCK_ERR	This parameter reflects the error status associated with the hardware or software components associated with a block. It is a bit string, so that multiple errors may be shown.
7	UPDATE_EVT	This alert is generated by any change to the static data
8	BLOCK_ALM	The block alarm is used for all configuration, hardware, connection failure or system problems in the block. The cause of the alert is entered in the subcode field. The first alert to become active will set the Active status in the Status parameter. As soon as the Unreported status is cleared by the alert reporting task, another block alert may be reported without clearing the Active status, if the subcode has changed.
9	TRANSDUCER_DIRECTORY	Directory that specifies the number and starting indices of the transducers in the transducer block.

Table C-16: Volume Transducer Block Parameters (continued)

Index Number	Parameter	Description
10	TRANSDUCER_TYPE	Identifies the transducer.
11	TRANSDUCER_TYPE_VER	
12	XD_ERROR	A transducer block alarm sub code.
13	COLLECTION_DIRECTORY	A directory that specifies the number, starting indices, and DD Item ID's of the data collections in each transducer within a transducer block.
14	LENGTH_UNIT	Same as in measurement transducer block
15	VOLUME_UNIT	Same as in measurement transducer block
16	VOLUME	Calculated volume and status
17	VOLUME_STATUS	Detailed status
18	LEVEL	Used level value
19	VOLUME_CALC_METHOD	Used volume calculation method
20	VOLUME_IDEAL_DIAMETER	Diameter for pre-defined standard tank type
21	VOLUME_IDEAL_LENGTH	Length for pre-defined standard tank type
22	VOLUME_OFFSET	Lets you use a non-zero volume for the zero level. Can be used in case you want to include the product volume below the zero level.
23	VOLUME_INTERPOLATE_METHOD	Interpolation method for levels between strapping table points
24	VOLUME_STRAP_TABLE_LENGTH	Number of strapping table points
25	STRAP_LEVEL_1_30	Level values for strapping points 1 to 30
26	STRAP_VOLUME_1_30	Volume values for strapping points 1 to 30

C.6 Register Transducer block

The Register Transducer block allows access to Database registers and Input registers. This makes it possible to read a selected set of register directly by accessing the memory location.

The Register Transducer block is only available with advanced service.

⚠ CAUTION

Since the Register Transducer block allows access to most registers, it should be handled with care and ONLY to be changed by trained and certified service personnel, or as guided by Emerson Automation Solutions support personnel.

Table C-17: Register Transducer Block Parameters

Index Number	Parameter	Description
1	ST_REV	The revision level of the static data associated with the function block. The revision value increments each time a static parameter value in the block is changed.
2	TAG_DESC	The user description of the intended application of the block.
3	STRATEGY	The strategy field can be used to identify grouping of blocks. This data is not checked or processed by the block.
4	ALERT_KEY	The identification number of the plant unit. This information may be used in the host for sorting alarms, etc.
5	MODE_BLK	The actual, target, permitted, and normal modes of the block. Target: The mode to “go to” Actual: The mode the “block is currently in” Permitted: Allowed modes that target may take on Normal: Most common mode for target
6	BLOCK_ERR	This parameter reflects the error status associated with the hardware or software components associated with a block. It is a bit string, so that multiple errors may be shown.
7	UPDATE_EVT	This alert is generated by any change to the static data
8	BLOCK_ALM	The block alarm is used for all configuration, hardware, connection failure or system problems in the block. The cause of the alert is entered in the subcode field. The first alert to become active will set the Active status in the Status parameter. As soon as the Unreported status is cleared by the alert reporting task, another block alert may be reported without clearing the Active status, if the subcode has changed.
9	TRANSDUCER_DIRECTORY	Directory that specifies the number and starting indices of the transducers in the transducer block.
10	TRANSDUCER_TYPE	Identifies the transducer.
11	TRANSDUCER_TYPE_VER	Transducer type version
12	XD_ERROR	A transducer block alarm sub code.
13	COLLECTION_DIRECTORY	A directory that specifies the number, starting indices, and DD Item ID’s of the data collections in each transducer within a transducer block.
14	RB_PARAMETER	
15-44	INP_REG_n_TYPE	Describes characteristics of input register n. Indicates requested value is displayed as a floating point (/ decimal) number.

Table C-17: Register Transducer Block Parameters (continued)

Index Number	Parameter	Description
	INP_REG_n_FLOAT	Input register n value, displayed as floating point number
	INP_REG_n_INT_DEC	Input register n value, displayed as decimal number
45-74	DB_REG_n_TYPE	Describes characteristics of holding register n. Indicates requested value is displayed as a floating point (/ decimal) number.
	DB_REG_n_FLOAT	Holding register n value, displayed as floating point number.
	DB_REG_n_INT_DEC	Holding register n value, displayed as decimal number.
75	RM_COMMAND	Defines what action to perform; Read Input/Holding Register, Restart Device, Poll Program Complete.
76	RM_DATA	
77	RM_STATUS	
78	INP_SEARCH_START_NBR	Input register search start number
79	DB_SEARCH_START_NBR	Holding register search start number

C.7 Advanced Configuration Transducer block

Table C-18: Advanced Configuration Transducer Block Parameters

Index Number	Parameter	Description
1	ST_REV	The revision level of the static data associated with the function block. The revision value increments each time a static parameter value in the block is changed.
2	TAG_DESC	The user description of the intended application of the block.
3	STRATEGY	The strategy field can be used to identify grouping of blocks. This data is not checked or processed by the block.
4	ALERT_KEY	The identification number of the plant unit. This information may be used in the host for sorting alarms, etc.
5	MODE_BLK	The actual, target, permitted, and normal modes of the block. Target: The mode to “go to” Actual: The mode the “block is currently in” Permitted: Allowed modes that target may take on Normal: Most common mode for target

Table C-18: Advanced Configuration Transducer Block Parameters (continued)

Index Number	Parameter	Description
6	BLOCK_ERR	This parameter reflects the error status associated with the hardware or software components associated with a block. It is a bit string, so that multiple errors may be shown.
7	UPDATE_EVT	This alert is generated by any change to the static data
8	BLOCK_ALM	The block alarm is used for all configuration, hardware, connection failure or system problems in the block. The cause of the alert is entered in the subcode field. The first alert to become active will set the Active status in the Status parameter. As soon as the Unreported status is cleared by the alert reporting task, another block alert may be reported without clearing the Active status, if the subcode has changed.
9	TRANSDUCER_DIRECTORY	Directory that specifies the number and starting indices of the transducers in the transducer block.
10	TRANSDUCER_TYPE	Identifies the transducer.
11	TRANSDUCER_TYPE_VER	
12	XD_ERROR	A transducer block alarm sub code.
13	COLLECTION_DIRECTORY	A directory that specifies the number, starting indices, and DD Item ID's of the data collections in each transducer within a transducer block.
14	AUTO_CONF_MEAS_FUNC	Check box to enable manual settings of affected parameters
15	USED_EXTRA_ECHO_MIN_ULLAGE	Parameters and functions for Empty Tank Handling.
16	USED_EXTRA_ECHO_MAX_ULLAGE	See Empty tank handling for more information.
17	USED_EXTRA_ECHO_MIN_AMPL	
18	EXTRA_ECHO_MIN_ULLAGE	
19	EXTRA_ECHO_MAX_ULLAGE	
20	EXTRA_ECHO_MIN_AMPL	
21	USED_EMPTY_TANK_DETECTION_AREA	
22	EMPTY_TANK_DETECTION_AREA	
23	USED_ECHO_TIMEOUT	Parameters and functions for Echo Tracking.
24	USED_CLOSE_DIST	See Surface Echo Tracking for more information.
25	USED_SLOW_SEARCH_SPEED	
26	USED_FFT_MATCH_THRESH	

Table C-18: Advanced Configuration Transducer Block Parameters (continued)

Index Number	Parameter	Description
27	USED_MULT_MATCH_THRESH	
28	USED_MED_FILTER_SIZE	
29	USED_MIN_UPDATE_RELATION	
30	ECHO_TIMEOUT	
31	CLOSE_DIST	
32	SEARCH_SPEED	
33	FFT_MATCH_THRESHOLD	
34	MULT_MATCH_THRESHOLD	
35	MED_FILTER_SIZE	
36	MIN_UPDATE_RELATION	
37	USED_DIST_FILTER_FACTOR	Parameters for Filter Settings.
38	DIST_FILTER_FACTOR	See Filter setting for more information.
39	USE_LEVEL_MONITORING	A function which continuously scans the upper zone in the tank for new echoes. If an echo is found, which is not the present tracked surface, the function will initiate an instant jump to the upper echo. See Table C-22 .
40	DOUBLE_BOUNCE_OFFSET	Used for advanced configuration of spherical and horizontal cylinder tanks in case multiple reflections lead to incorrect interpretation of product surface level.
41	UPPER_PRODUCT_DC	Upper product dielectric constant
42	TANK_PRESENTATION_2	See Table C-12 .
43	AMPLITUDE_THRESHOLD	Echoes with amplitudes below the General Amplitude Threshold will be disregarded. Use this parameter to filter out noise.
44	ATP_LENGTH	Number of points in the Amplitude Threshold Point (ATP) table.
45	LENGTH_UNIT	Measurement unit for length parameters such as product level
46	LEVEL_RATE_UNIT	Measurement unit for level rate parameters.
47	SIGNAL_STRENGTH_UNIT	Measurement unit for amplitude of measurement signal.
48	ECHO_UPDATE	Refresh echo information in parameters 49 to 51. See Table C-20 .
49	ECHO_COMMAND	Save found echo as a registered false echo. Remove echo from registered false echo list. See Table C-21 .

Table C-18: Advanced Configuration Transducer Block Parameters (continued)

Index Number	Parameter	Description
50	ECHO_DISTANCE	Distance to found echo.
51	ECHO_AMPLITUDE	Signal Amplitude of found echo.
52	ECHO_CLASS	Classification of found echo, see Table C-19 .
53	ECHO_FALSE	Distance to registered false echo
54	ATP_DISTANCE	You can filter out weak disturbing echoes by creating a noise threshold table defined by ATP Distance and ATP Threshold points.
55	ATP_THRESHOLD	Amplitude threshold. See ATP_DISTANCE.

Table C-19: Echo Classification

VALUE	Description
0	Unknown
1	Irrelevant
2	Surface
3	False echo
4	Double Bounce
5	Secondary Surface
6	Tank Bottom Echo
7	Beam below surface
8	Beam above surface
9	LPG pin

Table C-20: Echo Update

VALUE	Description
0	Uninitialized
1	Normal operation
2	Read a snapshot of found echoes

Table C-21: Echo Command

VALUE	Description
0	Uninitialized
1	Add false echo
2	Remove false echo

Table C-22: Use Level Monitoring

VALUE	Description
0	Uninitialized
1	No
2	Yes

C.8 LPG Transducer block

The LPG transducer block contains parameters for setup and configuration of LPG calculations. It also contains parameters for verification and status of LPG corrections.

To be usable, the main transducer block has to include the appropriate source devices for gas pressure and gas temperature measurements.

See [LPG configuration](#) and [LPG Setup using DeltaV / AMS Device Manager](#) for more information on how to configure the Rosemount 5900S for LPG measurement. See also the application example in [Application example](#).

Table C-23: LPG-Hybrid Transducer Block Parameters

Index Number	Parameter	Description
1	ST_REV	The revision level of the static data associated with the function block. The revision value increments each time a static parameter value in the block is changed.
2	TAG_DESC	The user description of the intended application of the block.
3	STRATEGY	The strategy field can be used to identify grouping of blocks. This data is not checked or processed by the block.
4	ALERT_KEY	The identification number of the plant unit. This information may be used in the host for sorting alarms, etc.
5	MODE_BLK	The actual, target, permitted, and normal modes of the block. Target: The mode to “go to” Actual: The mode the “block is currently in” Permitted: Allowed modes that target may take on Normal: Most common mode for target
6	BLOCK_ERR	This parameter reflects the error status associated with the hardware or software components associated with a block. It is a bit string, so that multiple errors may be shown.
7	UPDATE_EVT	This alert is generated by any change to the static data

Table C-23: LPG-Hybrid Transducer Block Parameters (continued)

Index Number	Parameter	Description
8	BLOCK_ALM	The block alarm is used for all configuration, hardware, connection failure or system problems in the block. The cause of the alert is entered in the subcode field. The first alert to become active will set the Active status in the Status parameter. As soon as the Unreported status is cleared by the alert reporting task, another block alert may be reported without clearing the Active status, if the subcode has changed.
9	TRANSDUCER_DIRECTORY	Directory that specifies the number and starting indices of the transducers in the transducer block.
10	TRANSDUCER_TYPE	Identifies the transducer.
11	TRANSDUCER_TYPE_VER	
12	XD_ERROR	A transducer block alarm sub code.
13	COLLECTION_DIRECTORY	A directory that specifies the number, starting indices, and DD Item ID's of the data collections in each transducer within a transducer block.
14	LPG_SPECIAL_CONTROL	Special Control
15	LPG_CORRECTION_METHOD	Correction method
16	LPG_NUMBER_OF_GASSES	Number of gases
17	LPG_GAS_TYPE1	Gas type 1
18	LPG_GAS_PERC1	Percentage of gas type 1 in mixture of gases
19	LPG_GAS_TYPE2	Gas type 2
20	LPG_GAS_PERC2	Percentage of gas type 2 in mixture of gases
21	LPG_GAS_TYPE3	Gas type 3
22	LPG_GAS_PERC3	Percentage of gas type 3 in mixture of gases
23	LPG_GAS_TYPE4	Gas type 4
24	LPG_NUMBER_OF_PINS	Number of verification pins in the Still-pipe
25	LPG_PIN1_CONFIGURATION	Nominal position of Verification pin 1
26	LPG_PIN2_CONFIGURATION	Nominal position of Verification pin 2
27	LPG_PIN3_CONFIGURATION	Nominal position of Verification pin 3
28	LPG_PIN_TEMPERATURE	Ambient temperature when Verification Pin nominal position was entered.
29	LPG_PIN_TEMP_EXP_PPM	Expansion coefficient of still-pipe with verification pin
30	LPG_CORRECTION_ERROR	Correction error
31	LPG_CORRECTION_STATUS	Correction status
32	LPG_USED_GAS_PRESSURE	Gas pressure

Table C-23: LPG-Hybrid Transducer Block Parameters (continued)

Index Number	Parameter	Description
33	LPG_USED_GAS_PRESSURE_STATUS	Gas pressure status
34	LPG_USED_GAS_TEMP	Gas temperature
35	LPG_USED_GAS_TEMP_STATUS	Status of gas temperature measurement
36	LPG_VERIFICATION_STATE	
37	LPG_VERIFICATION_FAILURES	
38	LPG_VERIFICATION_WARNINGS	
39	LPG_VER_PIN1_MEAS	Measured position of verification pin 1
40	LPG_VER_PIN2_MEAS	Measured position of verification pin 2
41	LPG_VER_PIN3_MEAS	Measured position of verification pin 3
42	LPG_USER_GASPRESS_VALUE	
43	LPG_USER_GASTEMP_VALUE	
44	LPG_VERPIN_CORRPOS_1	Nominal position of verification pin 1
45	LPG_VERPIN_CORRPOS_2	Nominal position of verification pin 2
46	LPG_VERPIN_CORRPOS_3	Nominal position of verification pin 3
47	LPG_CORR_PPM	Pipe expansion coefficient
48	DEVICE_COMMAND	Command
49	LENGTH_UNIT	Measurement unit for length, see Supported units .
50	PRESSURE_UNIT	Measurement unit for pressure, see Supported units
51	TEMPERATURE_UNIT	Measurement unit for temperature, see Supported units
52	SIGNAL_STRENGTH_UNIT	Measurement unit for signal strength, see Supported units

Correction method

Table C-24: Identification Number for Various LPG Correction Methods

Value	Description
0	Air correction
1	One known gas
2	One or more unknown gases
3	Two gases, unknown mix ratio
4	Stable composition
100	Correction method 100

Table C-24: Identification Number for Various LPG Correction Methods (continued)

Value	Description
101	Correction method 101

Gas type

Table C-25: Identification Number for Various Gas Types

Value	Description
0	User gas 0
1	User gas 1
2	Default gas
3	Ammonia
4	N-Buthane
5	Isobuthane
6	Ethylene
7	Propadiene
8	Propylene
9	Propane
10	Air
11	Pentane
12	Isobuthylene
13	Chloroethylene
14	Nitrogen
100	LPG Gas 100
101	LPG Gas 101
102	LPG Gas 102

C.9 Supported units

Unit codes

Table C-26: Length Units

ID	Display	Description
1010	m	meter
1012	cm	centimeter
1013	mm	millimeter
1018	ft	feet
1019	in	inch

Table C-27: Level Rate Units

ID	Display	Description
1061	m/s	meter / second
1063	m/h	meter / hour
1067	ft/s	feet / second
1069	in/m	inch / minute
1073	ft/h	feet / hour

Table C-28: Temperature Units

ID	Display	Description
1000	K	Kelvin
1001	°C	Degree Celsius
1002	°F	Degree Fahrenheit

Table C-29: Signal Strength Units

ID	Display	Description
1243	mV	millivolt

Table C-30: Volume Units

ID	Display	Description
1034	m ³	Cubic meter
1043	ft ³	Cubic feet
1048	Gallon	US gallon
1051	Bbl	Barrel

Table C-31: Pressure Units

ID	Display	Description
1130	Pa	Pascal
1133	kPa	Kilo Pascal
1137	Bar	Bar
1138	mBar	Millibar
1140	atm	Atmospheres
1141	psi	pounds / square inch
1590	bar G	bar Gauge relative
1597	bar A	bar Absolute

Global Headquarters and Europe Regional Office Tank Gauging

Emerson Automation Solutions
Box 150
(Visiting address: Layoutvägen 1)
SE-435 23 Mölnlycke
Sweden

+46 31 337 00 00
+46 31 25 30 22
Sales.RTG@Emerson.com

North America Regional Office Tank Gauging

Emerson Automation Solutions
6005 Rogerdale Road
Mail Stop NC 136
Houston, TX 77072, USA

+1 281 988 4000 or +1 800 722 2865
Sales.RTG.HOU@Emerson.com

Latin America Regional Office

Emerson Automation Solutions
1300 Concord Terrace, Suite 400
Sunrise, FL 33323, USA

+1 954 846 5030
+1 954 846 5121
RMTLAContactUS@Emerson.com

Asia Pacific Regional Office

Emerson Automation Solutions
1 Pandan Crescent
Singapore 128461

+65 6777 8211
+65 6777 0947
Specialist-OneLevel.RMT-AP@Emerson.com

Middle East and Africa Regional Office

Emerson Automation Solutions
Emerson FZE
P.O. Box 17033
Jebel Ali Free Zone - South 2
Dubai, United Arab Emirates

+971 4 8118100
+971 4 8865465
RTGMEA.Sales@Emerson.com

 [Linkedin.com/company/Emerson-Automation-Solutions](https://www.linkedin.com/company/Emerson-Automation-Solutions)

 [Twitter.com/Rosemount_News](https://twitter.com/Rosemount_News)

 [Facebook.com/Rosemount](https://www.facebook.com/Rosemount)

 [Youtube.com/user/RosemountMeasurement](https://www.youtube.com/user/RosemountMeasurement)

©2019 Emerson. All rights reserved.

Emerson Terms and Conditions of Sale are available upon request. The Emerson logo is a trademark and service mark of Emerson Electric Co. Rosemount is a mark of one of the Emerson family of companies. All other marks are the property of their respective owners.