



**BOSCH**

Installer Guide

Air to water heat pump

**Compress 7400i AW**

5 OR | 7 OR

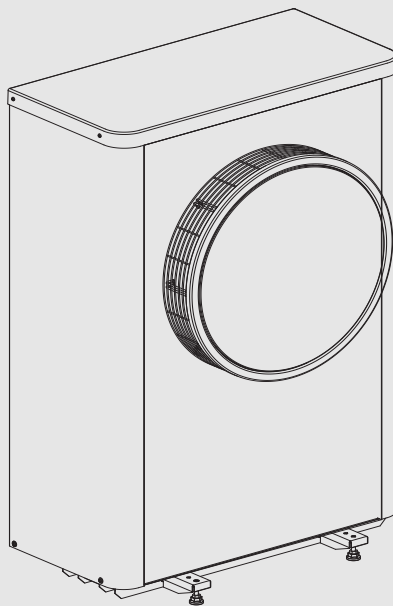

## Table of contents

<b>1</b>	<b>Explanation of symbols and safety instructions</b>	<b>2</b>
1.1	Explanation of symbols	2
1.2	General safety instructions	2
<b>2</b>	<b>Regulations</b>	<b>3</b>
2.1	Water quality	3
<b>3</b>	<b>Product description</b>	<b>5</b>
3.1	Scope of delivery	5
3.2	Heat pump details	5
3.3	Declaration of conformity	5
3.4	Type plate	5
3.5	Product overview	6
3.6	Dimensions	6
3.6.1	Dimensions of heat pump models 5 OR, 7 OR	6
3.7	Clearances during setup	7
<b>4</b>	<b>Preparing for installation</b>	<b>7</b>
4.1	Installation locations	7
4.2	For drainage	7
4.3	Minimum volume and execution of the heating system	8
<b>5</b>	<b>Installation</b>	<b>8</b>
5.1	Transport	8
5.1.1	Transport fitting	9
5.2	Unpacking	9
5.3	Checklist	9
5.4	Mounting method	9
5.4.1	Assembly of the heat pump	9
5.5	Connection	9
5.5.1	Pipework connections, general	9
5.5.2	Water connecting pipe	11
5.5.3	Connection of heat pump to the indoor unit	12
5.5.4	Electrical connection	12
5.6	Installing side panels and cover	14
<b>6</b>	<b>Maintenance</b>	<b>16</b>
<b>7</b>	<b>Installation of accessories</b>	<b>16</b>
7.1	Heating cable	16
<b>8</b>	<b>Environmental protection and disposal</b>	<b>18</b>
<b>9</b>	<b>Technical information</b>	<b>19</b>
9.1	Specifications – heat pump (alternating current)	19
9.2	Operating range of heat pump without auxiliary heater	20
9.3	Refrigerant circuit	21
9.4	Wiring diagram	22
9.4.1	Wiring diagram for transformer, alternating current	22
9.4.2	Wiring diagram for I/O module	23
9.4.3	Measurements for temperature sensor	24
9.5	Information on refrigerant	24

## 1 Explanation of symbols and safety instructions

### 1.1 Explanation of symbols

#### Warnings

In warnings, signal words at the beginning of a warning are used to indicate the type and seriousness of the ensuing risk if measures for minimizing danger are not taken.

The following signal words are defined and can be used in this document:



**DANGER**

**DANGER** indicates that severe or life-threatening personal injury will occur.



**WARNING**

**WARNING** indicates that severe to life-threatening personal injury may occur.



**CAUTION**

**CAUTION** indicates that minor to medium personal injury may occur.

#### NOTICE

**NOTICE** indicates that material damage may occur.

#### Important information



The info symbol indicates important information where there is no risk to people or property.

#### Additional symbols

Symbol	Meaning
▶	a step in an action sequence
→	a reference to a related part in the document
•	a list entry
–	a list entry (second level)

Table 1

### 1.2 General safety instructions

These installation instructions are intended for plumbers, heating system installers and electricians.

- ▶ Read all installation instructions (heat pump, control system etc) carefully before installation.
- ▶ Follow safety and warning instructions.
- ▶ Follow national and regional regulations, technical regulations and guidelines.
- ▶ Document all work that has been performed.

#### ⚠ Intended operation

This heat pump is intended to be used in a closed heating system for households. All other use is considered unsuitable. Any damage that is caused by such usage is excluded from liability.

**⚠ Installation, commissioning and service**

The heat pump may only be installed, brought into operation and maintained by authorised personnel.

- ▶ Use only original spare parts.

**⚠ Electrical work**

Electrical work may only be performed by authorised electrical installers.

Before commencing work:

- ▶ Disconnect mains voltage on all poles and ensure it cannot reconnect.
- ▶ Check to ensure that the power is disconnected.
- ▶ Also check the connection diagram for other parts of the system.

**⚠ Handover to the user**

When handing over, instruct the user how to operate the heating system and inform the user about its operating conditions.

- ▶ Explain how to operate the heating system and draw the user's attention to any safety relevant action.
- ▶ In particular, point out the following:
  - Modifications and repairs must only be carried out by an approved contractor.
  - Safe and environmentally compatible operation requires inspection at least once a year and proper cleaning and maintenance.
- ▶ Point out the possible consequences (personal injury, including danger to life or material damage) of non-existent or improper inspection, cleaning and maintenance.
- ▶ Leave the installation instructions and the operating instructions with the user for safekeeping.

**2 Regulations**

This is an original manual. This manual may not be translated without the approval of the manufacturer.

Follow the directives and regulations given below:

- Local provisions and regulations of the electricity supplier and corresponding special rules
- National building regulations
- **F-Gas regulation**
- **EN 50160** (Voltage characteristics of electricity supplied by public electricity networks)
- **EN 12828** (Heating systems in buildings - Design for water-based heating systems)
- **EN 1717** (Protection against pollution of potable water installations and general requirements of devices to prevent pollution by backflow)
- **EN 378** (Refrigerating systems and heat pumps - Safety and environmental requirements)

**2.1 Water quality**

**Water quality in the heating system**

Heat pumps operate at lower temperatures than other heating systems which means that the thermal de-airing is not as effective and oxygen levels are never as low as with a system incorporating an electric/oil/ gas boiler. This means that the heating system will be more susceptible to corrosion when exposed to aggressive water.

Preventive actions are required if the heating systems require recurrent filling or where a heating water sample does not show clear water.

Preventive actions can be to supplement the heating system with a magnetite filter and a de-airing valve.

Actions when the heating system requires recurrent filling:

- ▶ Check that the volume of the expansion vessel is sufficient for the heating system volume.
- ▶ Replace the expansion vessel.
- ▶ Check the heating system for leakages.

A system separation with the help of a heat exchanger may be required if the limits in table 2 can not be achieved.

The limits stated in table 2 are required to ensure the output data and operation of the heat pump throughout its entire life span.

Water quality	
Hardness	<3 °dH
Oxygen content	<1 mg/l
Carbon dioxide, CO <sub>2</sub>	<1 mg/l
Chloride ions, CL <sup>-</sup>	<250 mg/l
Sulphate, SO <sub>4</sub>	<100 mg/l
Conductivity	<350 µS/cm
pH	7,5 – 9

Table 2 Water quality

**Additional water treatment to prevent lime-scale deposits**

Poor quality of the heating water promotes the formation of sludge and lime-scale. This can lead to malfunctions and damage of the heat exchanger in the heat pump. According to the current guideline VDI 2035 "Avoidance of Damage in hot water heating systems" and depending on the degree of hardness of the filling water, the system volume and the total output of the system, water treatment may be required to avoid damage due to the formation of lime-scale.

**NOTICE**

**Risk of damage to system or appliance!**

Debris from the system can damage the appliance and reduce efficiency.

- ▶ Follow the guidance of BS7593 for treatment of water in domestic hot water heating systems<sup>1)</sup>.
- ▶ Do not use anti-freeze/glycol products.

**Suitable water treatment products (inhibitors/cleaners) can be obtained from the following manufacturers:**

ADEY	01242 546700 www.adey.com
FERNOX	0330 100 7750 www.fernox.com
SENTINEL	01928 704330 www.sentinelprotects.com/uk

Table 3

1) Only applicable in the United Kingdom.



If the limits for water hardness stated in table 2 are exceeded, the performance of the heat pump will deteriorate over time. If this performance degradation can be accepted, the limits in figure 1 are required to ensure the operation of the heat pump throughout its entire life span.

Heat pump output [kW]	Total alkalinity / total hardness of the filling water [°dh]	Maximum fill and top-up water volume $V_{\max}$ [m <sup>3</sup> ]
$\dot{Q} < 50$	Requirements according to figure 1	Requirements according to figure 1

Table 4 Table for heat pumps

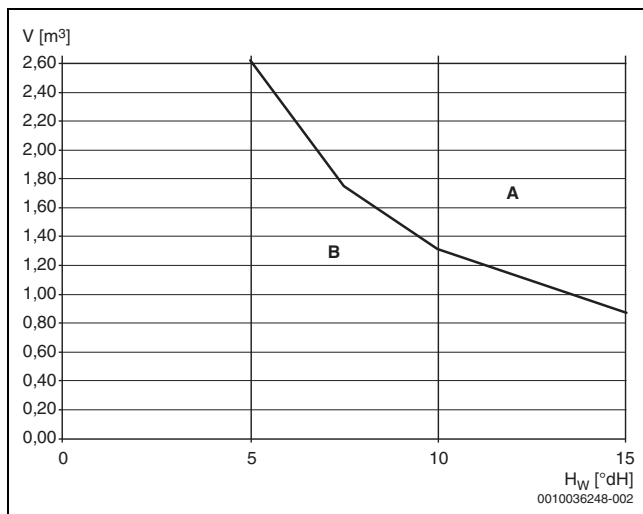

Fig. 1 Limits for water treatment in heat pump systems

- A Use completely de-mineralized fill water above the curve, conductivity  $\leq 10$  microsiemens /cm.
- B Use untreated tap water below the curve. Fill according to the drinking water regulation.
- $H_w$  Water hardness.
- $V$  Total water volume: Fill volume of the heating system and top-up volume over the life span of the heat pump.

If the total water volume is above the limit curve in the diagram ( $\rightarrow$ Fig. 1) suitable measures are required for water treatment.

Suitable measures are:

- Use of fully de-mineralized fill water with a Conductivity of  $\leq 10$  microsiemens / cm.

To prevent oxygen from entering the heating water, the expansion vessel must be adequately dimensioned.

When installing diffusion open pipes, a system separation with the help of a heat exchanger is required.

### 3 Product description

#### 3.1 Scope of delivery

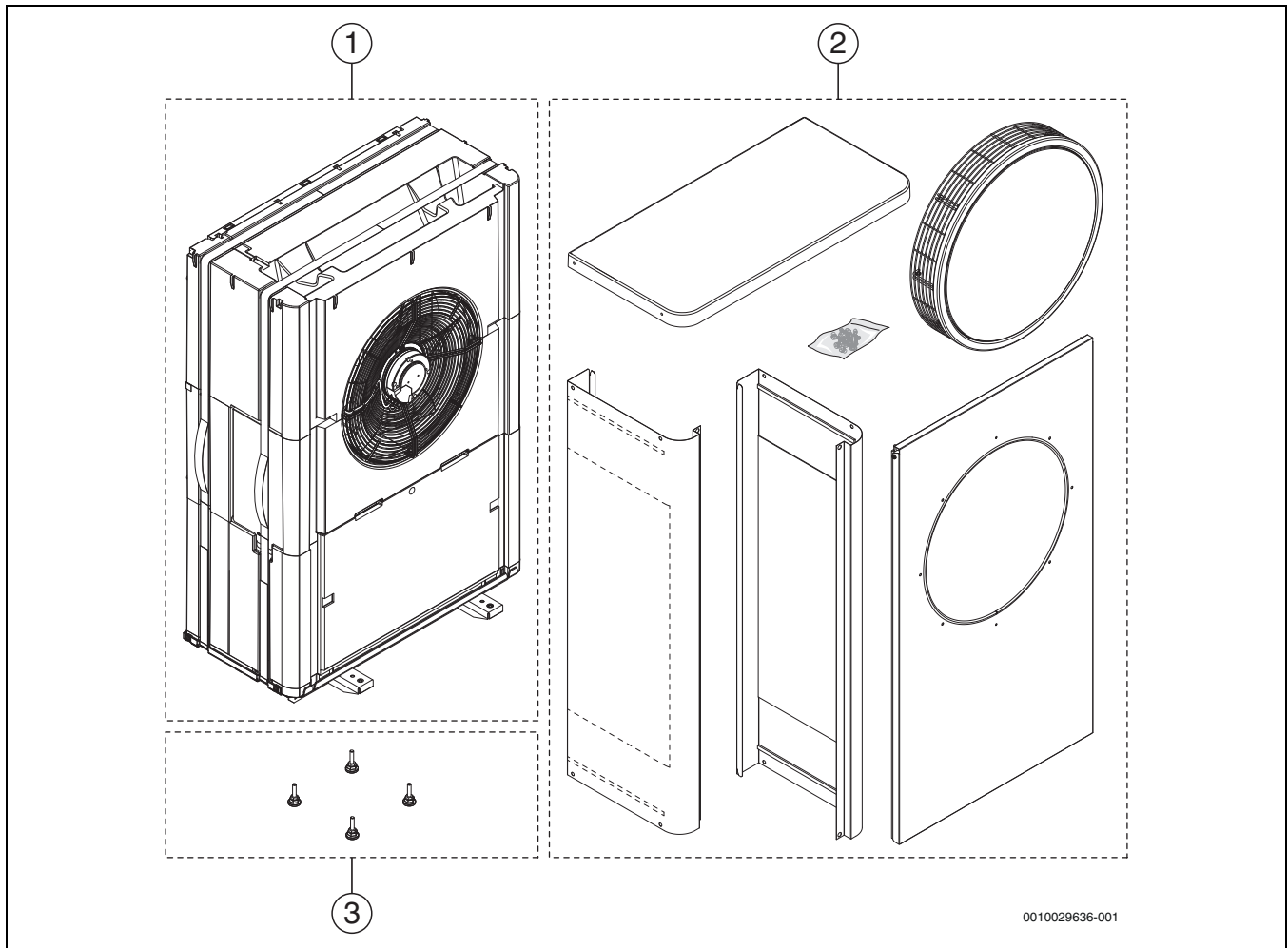

Fig. 2 Scope of delivery

- [1] Heat Pump
- [2] Cover and side panels
- [3] Tripod feet

#### 3.2 Heat pump details

The CS7400i AW heat pumps are intended for connection to the AWM/AWMS/AWMB or AWE/AWB indoor units.

Possible combinations:

AWM / AWMS / AWMB	AWE / AWB	CS7400i AW
9	9	5 OR
9	9	7 OR

Table 5 Outdoor unit combinations

AWM<sup>1)</sup>, AWMS<sup>2)</sup> and AWMB<sup>2)</sup> are equipped with an integrated electric booster heater.

AWMS<sup>2)</sup> is equipped with an integrated solar heat exchanger.

AWMB is equipped with an integrated buffer cylinder.

AWE is equipped with an integrated electric booster heater.

AWB<sup>2)</sup> is intended for an auxiliary heater (electric, oil and gas heating) with mixer.

1) Not available in United Kingdom.

2) Not available in United Kingdom and Ireland.

#### 3.3 Declaration of conformity

The design and operating characteristics of this product comply with the European and national requirements.

**CE** The CE marking declares that the product complies with all the applicable EU legislation, which is stipulated by attaching this marking.

The complete text of the Declaration of Conformity is available on the Internet: [worcester-bosch.co.uk](http://worcester-bosch.co.uk).

#### 3.4 Type plate

The data plate is located on the rear side of the heat pump. It contains information on the output, part number and serial number and also the date of manufacture. The product designation AirO S Hydro is also specified on the data plate.

### 3.5 Product overview

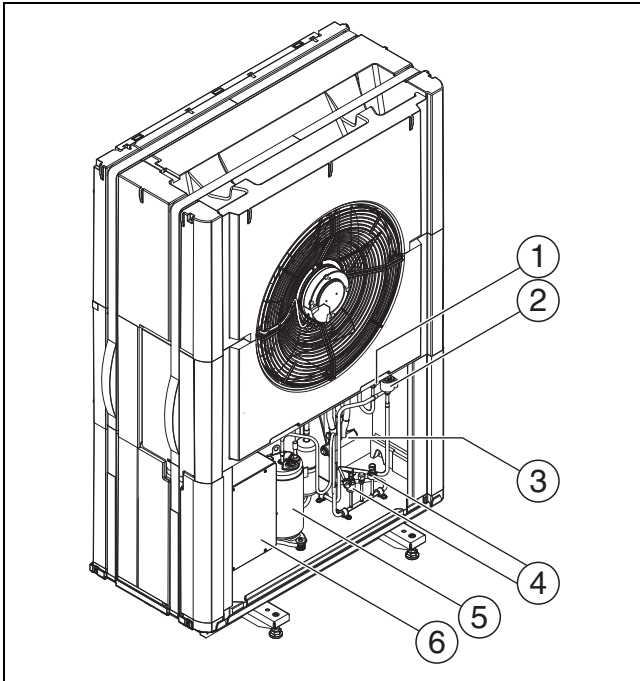

Fig. 3 Product overview

- [1] Electronic expansion valve VR1
- [2] Electronic expansion valve VRO
- [3] Four-way valve
- [4] Pressure switch/pressure sensor
- [5] compressor
- [6] Inverter



Description applies for all sizes.

### 3.6 Dimensions

#### 3.6.1 Dimensions of heat pump models 5 OR, 7 OR

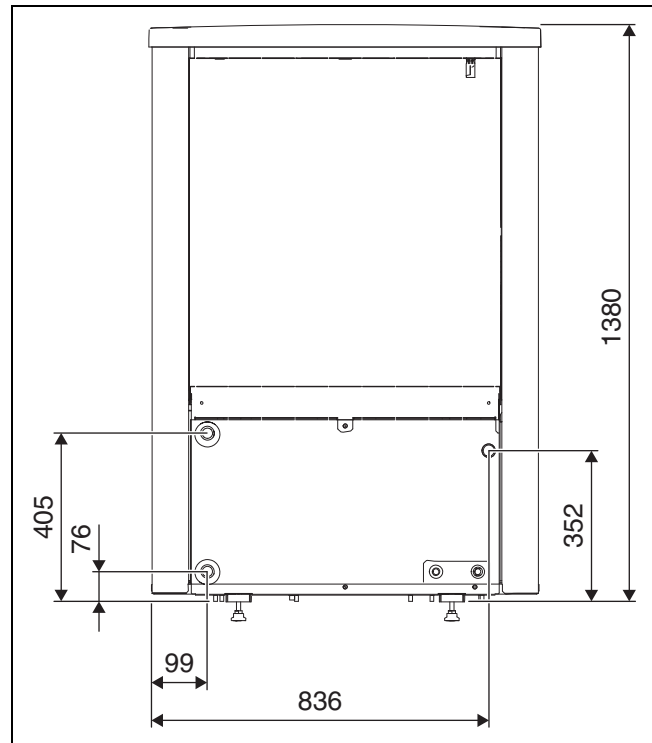

Fig. 4 Dimensions and connections of heat pump models 5 OR-7 OR, rear

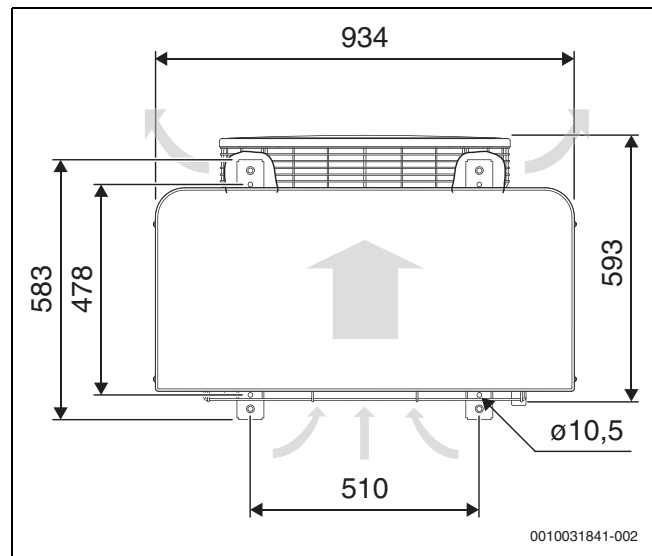

Fig. 5 Dimensions of heat pump models 5 OR-7 OR, view from top

### 3.7 Clearances during setup

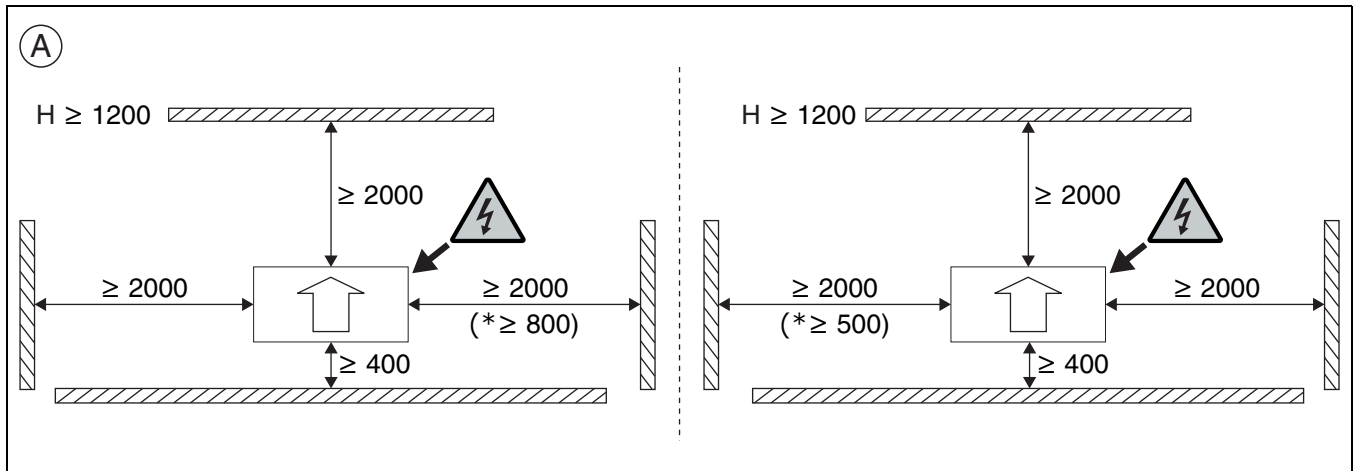

Fig. 6 Clearances during setup

- [\*] The clearance can be reduced on one side. This may however lead to a higher noise level.
- [A] Installation clearances of heat pump.

- ▶ With a freestanding installation (not near the building):
  - Do not install the heat pump so the intake side faces directly south to avoid the effects of the sun on the air temperature sensor.
  - Use a wall or similar object to protect the intake side.

## 4 Preparing for installation

### 4.1 Installation locations

- ▶ Place the heat pump outdoors on a flat stable surface.
- ▶ When setting up the heat pump, make sure it can be accessed at all times in order to carry out maintenance work. If access is restricted, e.g. due to installation on a roof, suitable measures must be taken to ensure that maintenance work can still be carried out without additional time expenditure or costly assembly aids.
- ▶ Bear in mind the sound propagation of the heat pump when placing it, particularly in view of avoiding of noise nuisance to neighbours.
- ▶ Whenever possible, do not place the heat pump in front of rooms sensitive to noise.
- ▶ Do not place the heat pump in a corner where it is flanked by walls on 3 sides. This can increase the noise level and soiling of the evaporator.

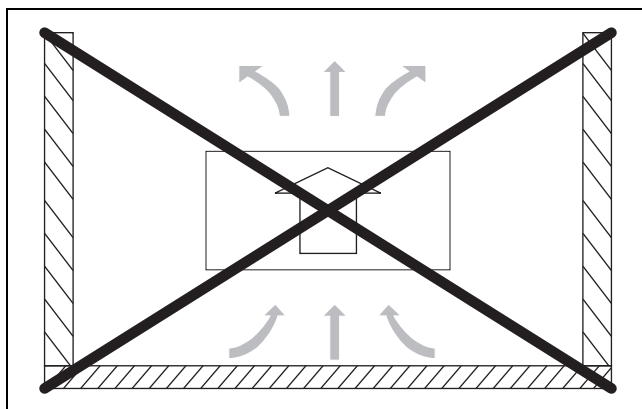

Fig. 7 Avoid setting up in locations surrounded by walls

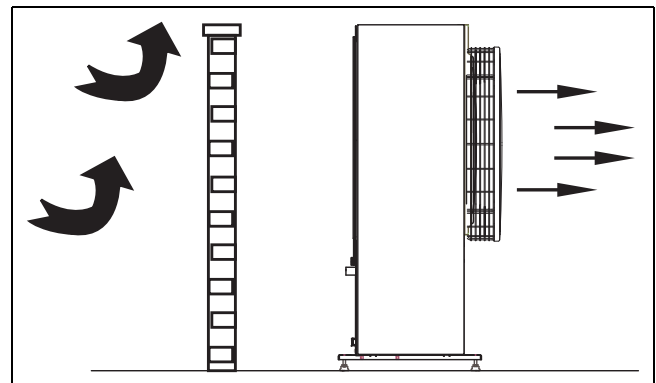

Fig. 8 Free standing heat pump

- ▶ Whenever possible, set up the heat pump so that the front is not directly facing the wind.
- ▶ Position the outdoor unit of the heat pump so that no snow or water from the roof drips or slides onto it. If this cannot be avoided, a protective roof must be installed.



If a protective roof is installed above the heat pump, bear in mind that it must be possible to lift the thermal insulation material of the heat pump up and off.

- ▶ With the models 5 OR–7 OR, make sure there is a clearance of at least 500 mm between the roof and heat pump.
- ▶ If the roof can be removed, the minimum clearance above the heat pump for all models is 400 mm.

### 4.2 For drainage

Remove condensate via a frost-free drain of the heat pump, possibly equipped with pipe trace heating. The drain must slope sufficiently to prevent water from accumulating in the pipe.

The condensate can be routed to either a gravel bed, a stone box or into a rainwater gully.

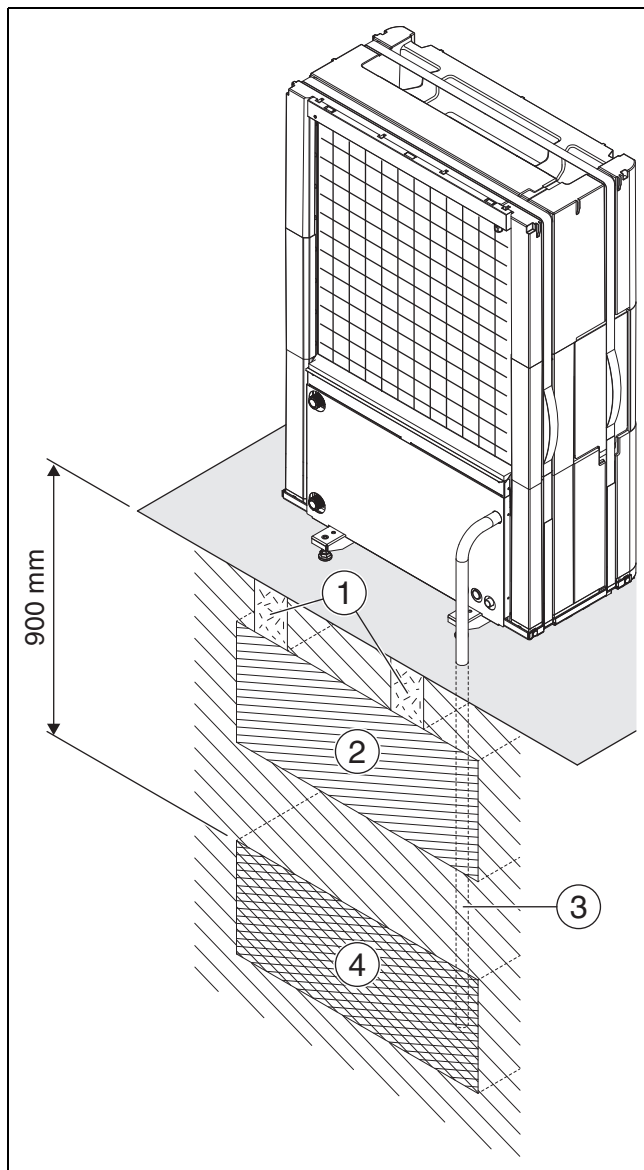

Fig. 9 Condensate pipe in gravel bed

- [1] Concrete foundations
- [2] Shingle 300 mm
- [3] Condensate tube 32 mm
- [4] Gravel bed

### 4.3 Minimum volume and execution of the heating system



To safeguard the heat pump function and avoid an excessive number of start/stop cycles, incomplete defrosting and unnecessary alarms, it must be possible to store a sufficient amount of energy in the system. This energy is stored in the water volume of the heating system, and also in the components of the system (radiators) and concrete floor (underfloor heating system).

As the requirements for different heat pump installations and heating systems vary considerably, a minimum water volume in litres is generally not specified. Instead, the system volume is considered to be sufficient if certain conditions are met.

#### Underfloor heating system without buffer cylinder

A room temperature-dependent control unit should be installed in the largest room (reference room) instead of room thermostats. Small floor

areas can lead to the auxiliary heater being activated in the final phase of the defrosting process.

- $\geq 6 \text{ m}^2$  floor area required for heat pump 5 OR – 7 OR.

To ensure maximum energy savings and avoid auxiliary heater operation, the following configuration is recommended:

- $\geq 30 \text{ m}^2$  floor area for heat pump 5 OR – 7 OR.

#### System with radiators without mixer and buffer cylinder

If the system only contains a few radiators, the auxiliary heater may be activated in the final phase of the defrosting process. The radiator thermostats must be opened fully.

- $\geq 1$  radiator with 500 W rating required for heat pump 5 OR – 7 OR.

To ensure maximum energy savings and avoid auxiliary heater operation, the following configuration is recommended:

- $\geq 4$  radiators with 500 W rating for heat pump 5 OR – 7 OR.

#### Heating system with underfloor heating system and radiators in separate heating circuits without buffer cylinders

A room temperature-dependent control unit should be installed in the largest room (reference room) instead of room thermostats. Small floor areas or only a few radiators in the system can lead to the auxiliary heater being activated in the final phase of the defrosting process.

- $\geq 1$  radiator with 500 W rating required for heat pump 5 OR – 7 OR.

Although a minimum floor area is not required for the underfloor heating circuit, to avoid auxiliary heater operation and achieve optimum energy savings, additional heating thermostats or several valves of the underfloor heating system must be at least partially open.

#### Only heating circuits with mixer

A buffer cylinder is essential in heating systems consisting only of heating circuits with mixer.

- Required volume for heat pump 5 OR – 7 OR =  $\geq 50$  litres.

#### Only fan convectors

To prevent the auxiliary heater from being activated in the final phase of the defrosting process, a buffer storage tank with a capacity of  $\geq 10 \text{ l}$  is required.

## 5 Installation

### NOTICE

#### Damage to the heat pump due to water!

Electrical connections and electronics can be damaged if they are exposed to water. The outer casing is a prerequisite for meeting the heat pump's IP rating.

- ▶ The heat pump must not be stored outdoors without its side panels, front plate and roof.
- ▶ Mount side panels, front plate and roof without delay after all connections are done.

### 5.1 Transport

The heat pump must always be transported and stored in an upright position. It can be tilted provisionally, but not laid flat.

The heat pump must not be stored at temperatures below  $-20^\circ\text{C}$ .

The heat pump can be carried by the belt handles.

**5.1.1 Transport fitting**

The heat pump is equipped with a transport fitting (screw) which is clearly identified by a red marking. The transport fitting prevents the heat pump from being damaged in transit. Unscrew transport fitting.

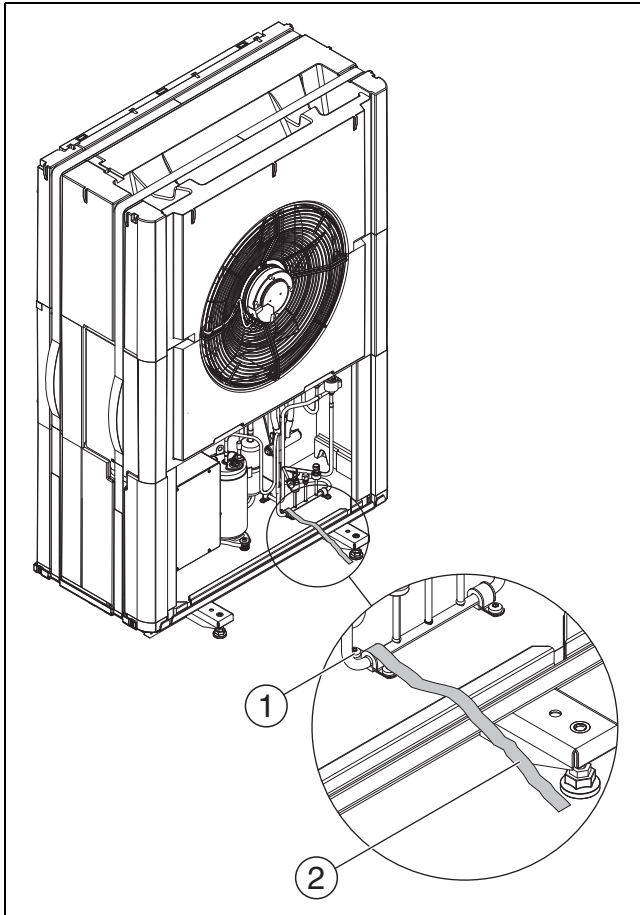

Fig. 10 Transport fitting

- [1] Transport fitting
- [2] Red marking

**5.2 Unpacking**

- ▶ Remove the packaging according to the instructions on the packaging.
- ▶ Take out enclosed accessories.
- ▶ Check that all package contents are present.

**5.3 Checklist**



Each installation is different. The checklist below provides a general description of the installation process.

1. Install and fix the heat pump on a solid surface.
2. Install condensate tube of the heat pump and possibly the pipe trace heating.
3. Connect heat pump to the indoor unit.
4. Connect CAN-BUS cable to heat pump and indoor unit.
5. Connect power supply of the heat pump.
6. Mount side panels and cover of heat pump.

**5.4 Mounting method**

**5.4.1 Assembly of the heat pump**

**CAUTION**

**Risk of trapping or injury!**

The heat pump may tilt if it is not fixed correctly.  
 ▶ Fix the heat pump to the floor.

**NOTICE**

**Installation problems/faults if installed on sloping surface!**

This will hamper the assembly of the side panels and cover. The condensate drainage and functionality will be impaired.

- ▶ Make sure that the inclination of the heat pump in the horizontal and vertical direction is no more than 1%.
- ▶ Screw the heat pump to the subsurface using suitable screws.
- ▶ Align the heat pump horizontally using the adjustable feet.

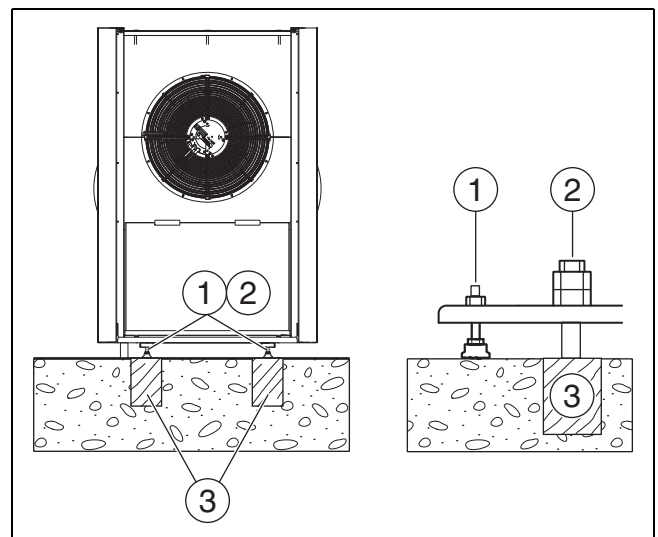

Fig. 11 Fastening the heat pump

- [1] Adjustable feet
- [2] 4 pieces M10 X120 mm (not included in scope of delivery)
- [3] Level subsurface with sufficient load bearing capacity, e.g. concrete foundations

**5.5 Connection**

**5.5.1 Pipework connections, general**

**NOTICE**

**Residue in the pipework can damage the system.**

Solids, metal/plastic filings, flux and thread tape residue and similar material can get stuck in pumps, valves and heat exchangers.

- ▶ Keep foreign bodies from entering the pipework.
- ▶ Do not leave pipe parts and connections directly on the ground.
- ▶ When deburring, make sure that no residue remains in the pipe.
- ▶ Before connecting the heat pump and indoor unit, rinse the pipe system to remove any foreign bodies.

**NOTICE****Material damage due to frost and UV radiation!**

In case of a power outage the water in the pipes may freeze.

The insulation may become brittle due to UV radiation and crack after some time.

- ▶ Use insulation with a thickness of at least 19 mm for pipework and connections outdoors.
- ▶ Install drain valves so that the water can be drained out of the lines to and from the heat pump if it is not going to be used for some time or if there is a risk of frost.
- ▶ Use UV and moisture-resistant insulation.

**Insulation/Sealing**

- ▶ All heat-conducting pipework must be provided with suitable thermal insulation according to applicable regulations.
- ▶ In cooling mode, all connections and lines must be insulated according to applicable standards to prevent condensation.
- ▶ Seal wall outlet.



Dimension pipes according to instructions (→Tab. 6–9).

- ▶ To minimise pressure drops, avoid joints in the heat transfer medium line.
- ▶ Use PEX pipes for all pipework between the heat pump and indoor unit.
- ▶ To avoid leaks, only use material (pipes and connections) from the same PEX supplier.
- ▶ To make installation easier and to avoid breaks in the insulation, use of insulated AluPEX pipes is recommended. The purpose of PEX and AluPEX pipes is to damp vibrations and reduce noise transmission to the heating system.



If materials other than PEX are used, the following prerequisites must be met:

- ▶ Install a particle filter which is suitable for use outdoors in the return to the heat pump directly at the heat exchanger.
- ▶ Insulate the particle filter and also the other connections.
- ▶ Establish the connection to the heat pump using a vibration-damping hose which is suitable for use outdoors and also insulate it.

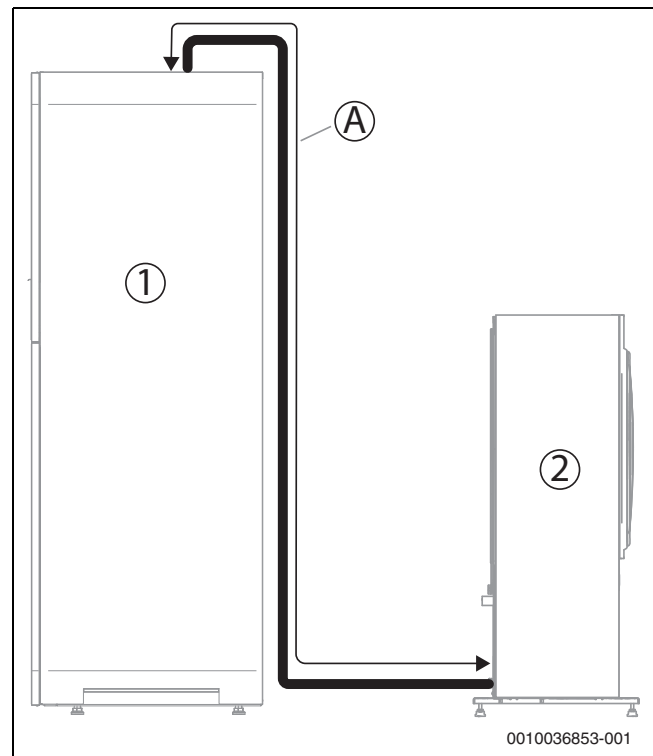

Fig. 12 Pipe length A

- [1] Indoor unit floor standing
- [2] Heat pump

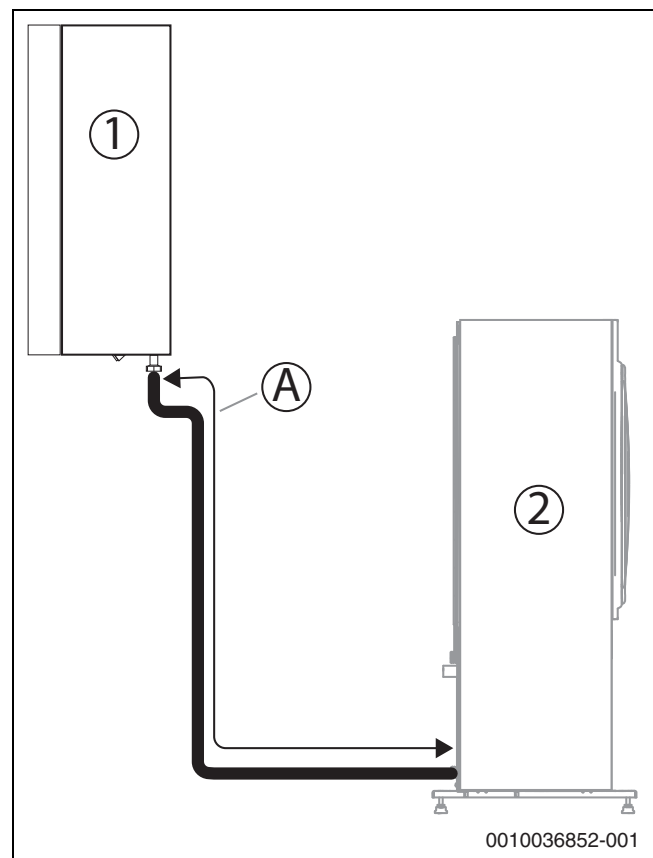

Fig. 13 Pipe length A

- [1] Indoor unit wall mounted
- [2] Heat pump

Heat Pump	Delta heat transfer medium (K)	Nominal flow rate (l/s)	Maximum pressure reduction (kPa) <sup>1)</sup>	AX20 inside Ø 15 (mm)	AX25 inside Ø 18 (mm)	AX32 inside Ø 26 (mm)	AX40 inside Ø 33 (mm)
				Maximum pipe length [A, 13] PEX (m)			
5 OR	5	0.33	55	7	16.5	30	
7 OR	5	0.43	40	4	10.5	30	

1) For pipes and components between the heat pump and indoor unit.

Table 6 Pipe dimensions and maximum pipe lengths (single section) for connecting the heat pump to the indoor unit AWMM

Heat Pump	Delta heat transfer medium (K)	Nominal flow rate (l/s)	Maximum pressure reduction (kPa) <sup>1)</sup>	AX20 inside Ø 15 (mm)	AX25 inside Ø 18 (mm)	AX32 inside Ø 26 (mm)	AX40 inside Ø 33 (mm)
				Maximum pipe length [A, 13] PEX (m)			
5 OR	5	0.33	56	7	10	30	30
7 OR	5	0.44	46	4	10	30	30

1) For pipes and components between the heat pump and indoor unit.

Table 7 Pipe dimensions and maximum pipe lengths (single section) for connecting the heat pump to the indoor unit AWMB

Heat Pump	Delta heat transfer medium (K)	Nominal flow rate (l/s)	Maximum pressure reduction (kPa) <sup>1)</sup>	AX20 inside Ø 15 (mm)	AX25 inside Ø 18 (mm)	AX32 inside Ø 26 (mm)	AX40 inside Ø 33 (mm)
				Maximum pipe length [A, 13] PEX (m) <sup>2)</sup>			
5 OR	7	0.32	52	8.5	22	30	
7 OR	7	0.32	54		22.5	30	

1) For pipes and components between the heat pump and indoor unit.

2) The installation of a 3-way valve in the DHW circuit of the system was factored into the calculation of the pipe lengths.

Table 8 Pipe dimensions and maximum pipe lengths (single section) when connecting the heat pump to the AWB indoor unit with mixer for the external auxiliary heater

Heat Pump	Delta heat transfer medium (K)	Nominal flow rate (l/s)	Maximum pressure reduction (kPa) <sup>1)</sup>	AX20 inside Ø 15 (mm)	AX25 inside Ø 18 (mm)	AX32 inside Ø 26 (mm)	AX40 inside Ø 33 (mm)
				Maximum pipe length [A, 13] PEX (m) <sup>2)</sup>			
5 OR	5	0.34	57	8.5	21.5	30	
7 OR	5	0.43	44		10.5	30	

1) For pipes and components between the heat pump and indoor unit.

2) The installation of a 3-way valve in the DHW circuit of the system was factored into the calculation of the pipe lengths.

Table 9 Pipe dimensions and maximum pipe lengths (single section) for connecting the heat pump to the AWE indoor unit with integrated electric booster heater

### 5.5.2 Water connecting pipe

#### NOTICE

#### Damage due to risk of frost!

If the condensate freezes and cannot be routed away from the heat pump, the evaporator may be damaged.

- ▶ Always install pipe trace heating if ice is likely to form in the condensate hose.

Remove condensate via a frost-free drain of the heat pump, possibly equipped with pipe trace heating. The drain must slope sufficiently to prevent water from accumulating in the pipe.

The condensate can be routed to either a gravel bed, a stone box or into a rainwater gully.

- ▶ Route 32 mm plastic pipe from the condensate connection to a drain.
- ▶ Connection of pipe trace heating → Chapter 7.1.

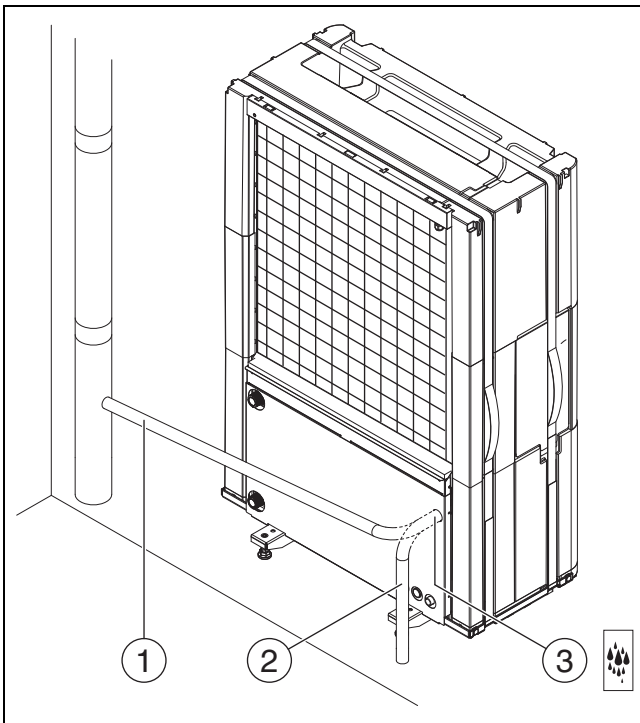

Fig. 14 Condensate tube connections, valid for all sizes

- [1] Condensate line in rainwater gully
- [2] Condensate line in gravel bed/stone box
- [3] Connection for condensate tube

### 5.5.3 Connection of heat pump to the indoor unit

#### NOTICE

#### Material damage due to excessively high starting torque!

If connections are tightened too tightly, the heat exchanger may be damaged.

- ▶ When installing the connection, the tightening torque should be no more than 150 Nm.



Short pipe runs outdoors reduce heat losses. Use of pre-insulated pipes is recommended.

- ▶ Use pipes in accordance with Chapter 5.5.1.
- ▶ Connect flow to the indoor unit at the heat transfer medium outlet of the heat pump (→ [1], Fig. 15).
- ▶ Connect return from the indoor unit at the heat transfer medium inlet of the heat pump (→ [2], Fig. 15).
- ▶ Tighten connections of the heat transfer medium pipes with a starting torque of 120 Nm. Direct the force downwards (→ Fig. 15) to avoid lateral loading of the condenser.  
If the connection does not seal properly, the joint can be tightened with a starting torque of up to 150 Nm. If the connection is still not tight, this indicates that the gasket or connected pipe is damaged.

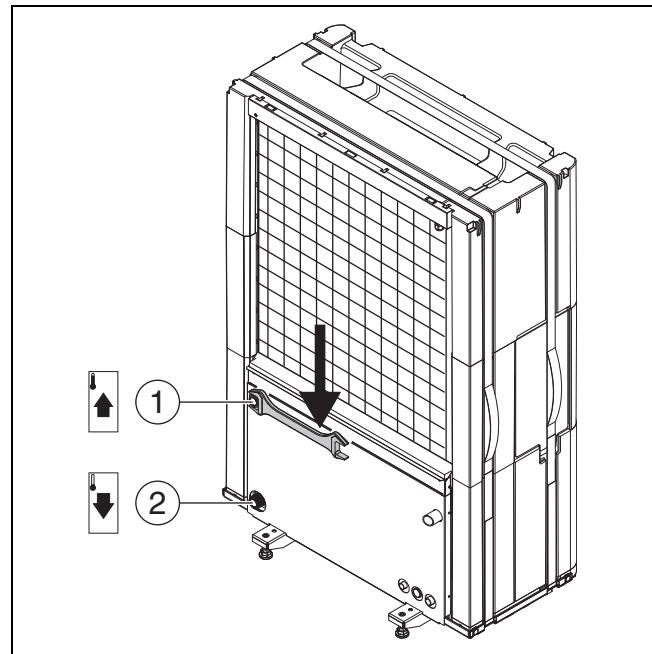

Fig. 15 Connections of heat carrying medium pipes, valid for all sizes

- [1] Heat transfer medium outlet (to the indoor unit) DN25
- [2] Heat transfer medium inlet (from the indoor unit) DN25

### 5.5.4 Electrical connection

#### NOTICE

#### Malfunction due to faults!

High-voltage lines (230/400 V) in the vicinity of communication lines can cause the heat pump to malfunction.

- ▶ Route sensor cable, EMS-BUS cable and shielded CAN-BUS cable separately to power cables. Maintain a minimum distance of 100 mm. The BUS cable can be routed together with sensor cables.



The unit's electrical connection must be able to be disconnected safely.

- ▶ Install a separate safety switch that disconnects all power to the heat pump if it is not supplied via the indoor unit. For a separate power supply, a safety switch is required for each supply.

- ▶ Select the appropriate conductor cross-sections and cable types for the respective fuse protection and routing method.
- ▶ Connect the heat pump according to the wiring diagram. No more users can be connected.
- ▶ Install a separate residual current device according to applicable standards in each country. We recommend a type B residual current device.
- ▶ When changing the PCB, note the colour coding.

### CAN-BUS

#### NOTICE

#### The system will be damaged if the 12 V- and the CAN-BUS connections are incorrectly connected!

The communication circuits are not designed for 12 V constant voltage.

- ▶ Check to ensure that the cables are connected to the contacts with the corresponding markings on the modules.

The heat pump and indoor unit are connected by a communication line, CAN-BUS.

**A suitable cable for external cable installation** is wire LIYCY (TP) 2x2x0,75, or equivalent. An alternative cable should have a cross section area of at least 0,75 mm<sup>2</sup>, and be a duplex cable, screened and approved for outside use. The screen should only be earthed to the chassis at one end (the indoor unit).

Maximum cable length is 30 m.

The connection is made with four wires, as the 12 V supply is also connected. On the circuit board there is a marking for 12 V and CAN-BUS connections.

**Switch Term** is used to indicate the start and end of a CAN-BUS loop. The heat pump I/O module card should be terminated.

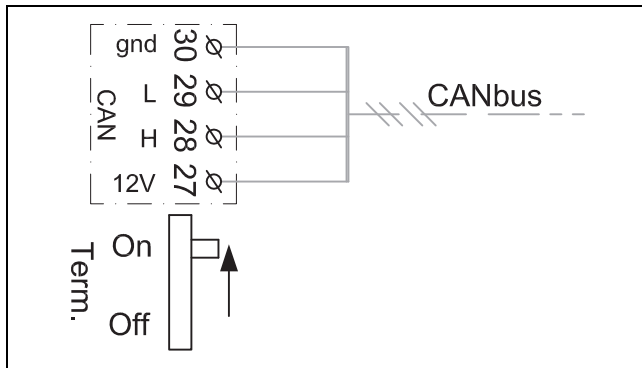

Fig. 16 Termination CAN-BUS

**Connecting the heat pump**



A CAN-BUS signal cable with the minimum dimensions 4 x 0.75 mm<sup>2</sup> and a maximum length of 30 m must be routed between the heat pump and indoor unit.

- ▶ Release belt (Velcro fastener).
- ▶ Remove the lock of the control device.
- ▶ Feed the connecting lead through the cable conduits. Use tension springs if required.
- ▶ Connect cable as shown in the wiring diagram.
- ▶ Tighten all cable fixings if required.
- ▶ Reattach the cover of the control device.
- ▶ Reattach the belt.

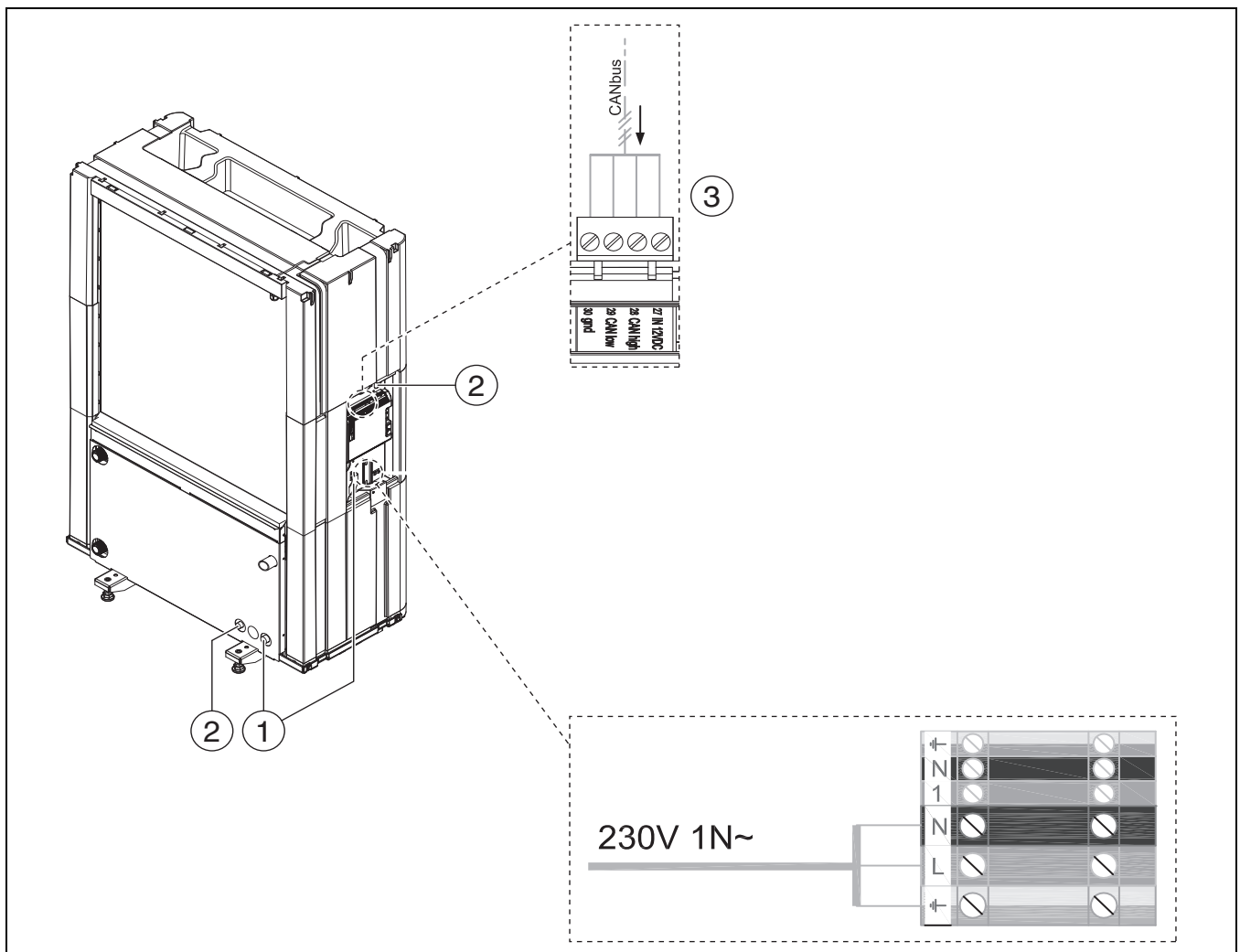
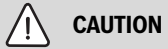

Fig. 17 Cable conduits and control device

- [1] Cable conduit, power supply
- [2] Cable conduit CAN-BUS
- [3] Connection CAN-BUS

### 5.6 Installing side panels and cover



**CAUTION**

**Risk of injury!**

There is a risk of hand injury if the fan is uncovered.

► The unit may not be commissioned without the front plate.

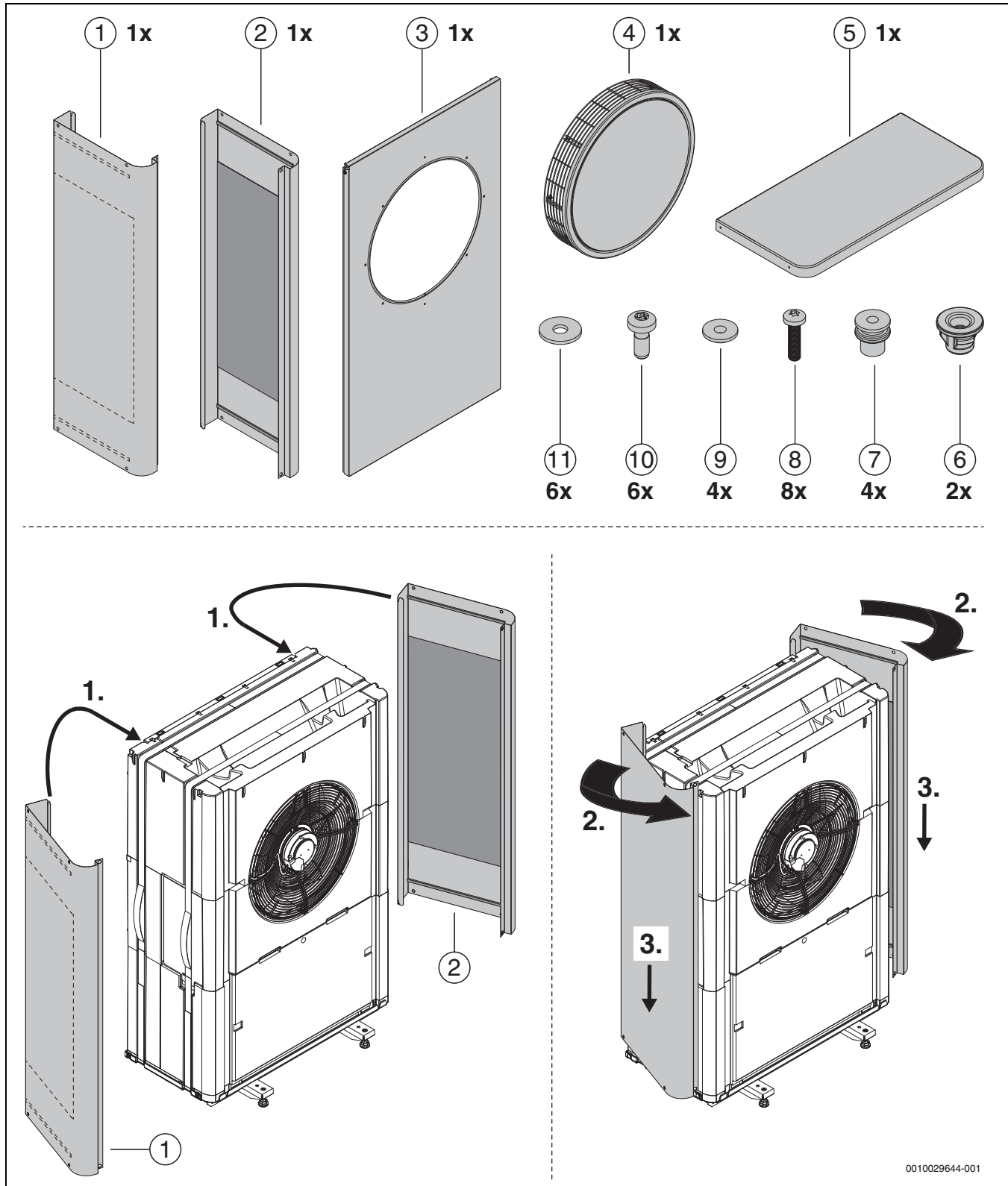

Fig. 18 Installing side panels and cover

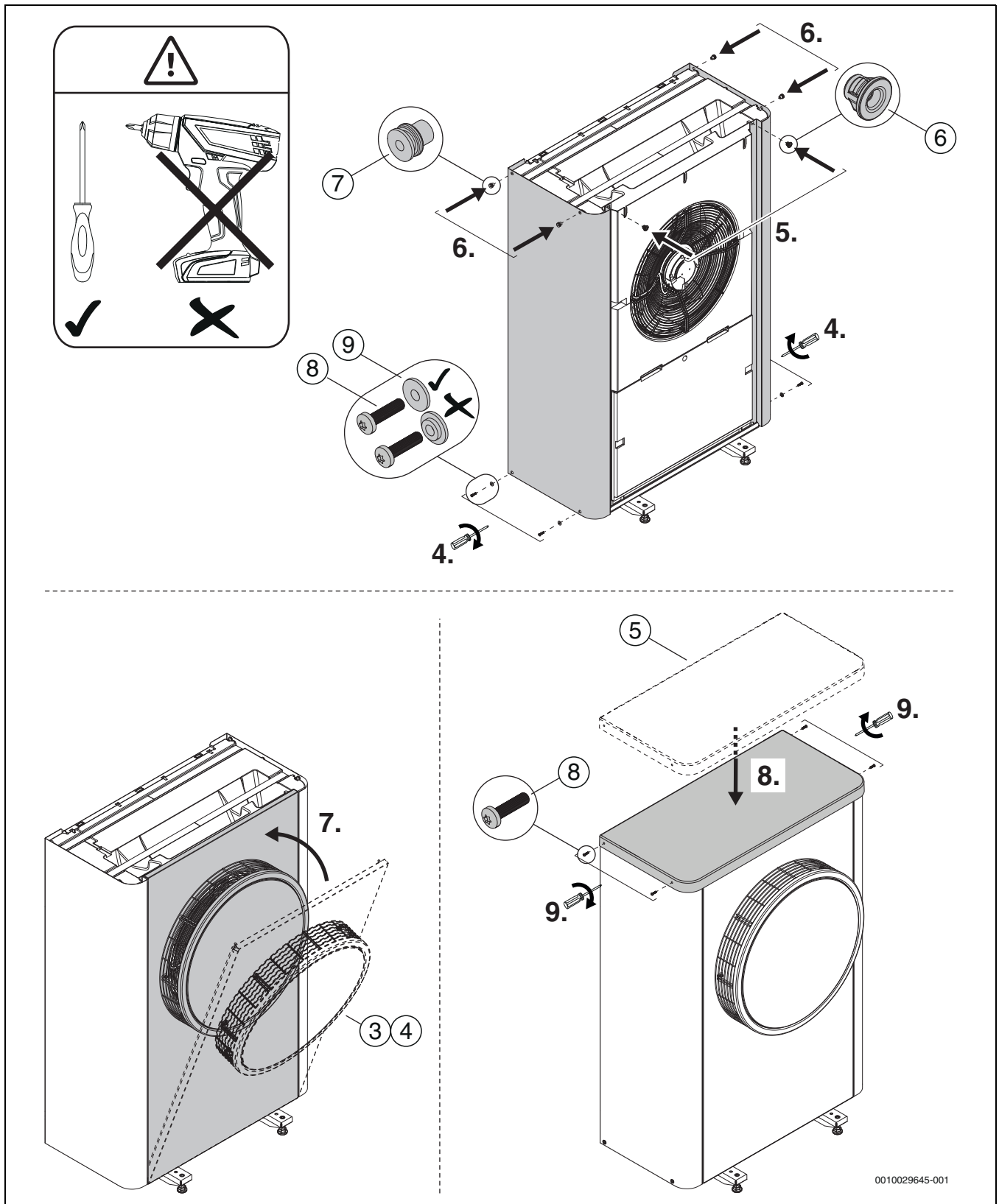

Fig. 19 Installing side panels and cover

## 6 Maintenance



### Electrical shock!

The heat pump contains current-carrying components and the heat pump capacitor must be discharged once the power supply has been disconnected.

- ▶ Isolate the system from the supply.
- ▶ Wait at least five minutes before carrying out electrical work.



### Poisonous gas leakage!

The refrigerant circuit contains substances that can be transformed into poisonous gas if they come into contact with air or open fire. Even in small concentrations, these gases can cause respiratory failure.

- ▶ Leave the area immediately if the refrigerant circuit is leaking and ventilate thoroughly.

### NOTICE

#### Malfunction due to damage!

The electronic expansion valves are highly sensitive to impacts.

- ▶ Always protect the expansion valve from impacts and shock.

### NOTICE

#### Deformation due to heat!

If the temperature is too high, the insulation material (EPP) in the heat pump deforms.

- ▶ Remove as much insulation (EPP) as possible before carrying out soldering work.
- ▶ When carrying out soldering work in the heat pump, protect the insulation material with heat-resistant materials or a moist cloth.



Work on the refrigerant circuit must only be carried out by experts with the relevant qualifications.

- ▶ Only use genuine spare parts!
- ▶ Refer to the spare parts list when ordering spare parts.
- ▶ Replace removed gaskets and O-rings with new ones.

The tasks described below must be carried out during an inspection.

#### Display activated alarm

- ▶ Check alarm log (→ controller manual).

#### Function test

- ▶ Perform function check (→ indoor unit installation instructions).

#### Install power cable

- ▶ Check the power cable for mechanical damage.
- ▶ Replace damaged cables.

## 7 Installation of accessories

### 7.1 Heating cable

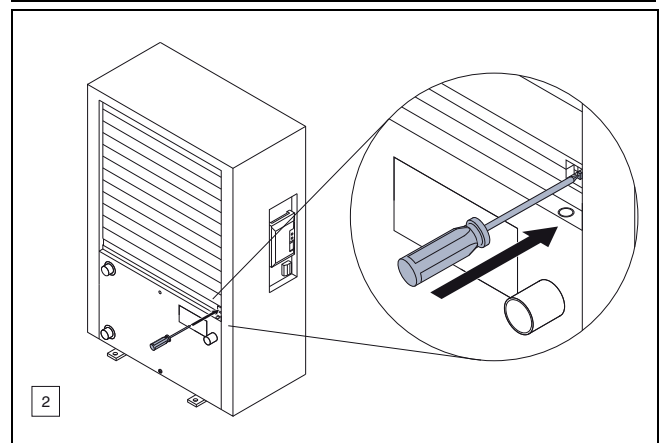
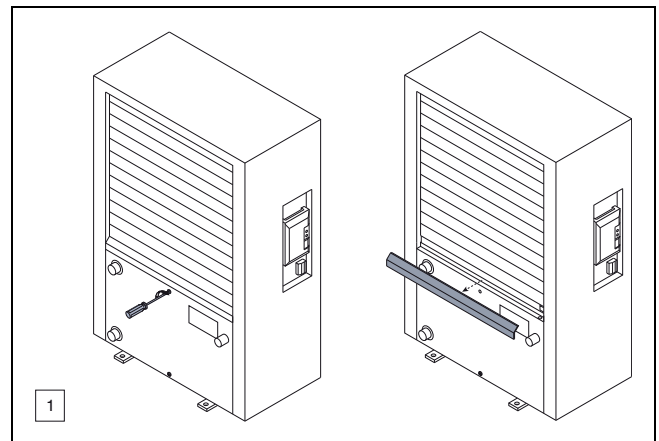
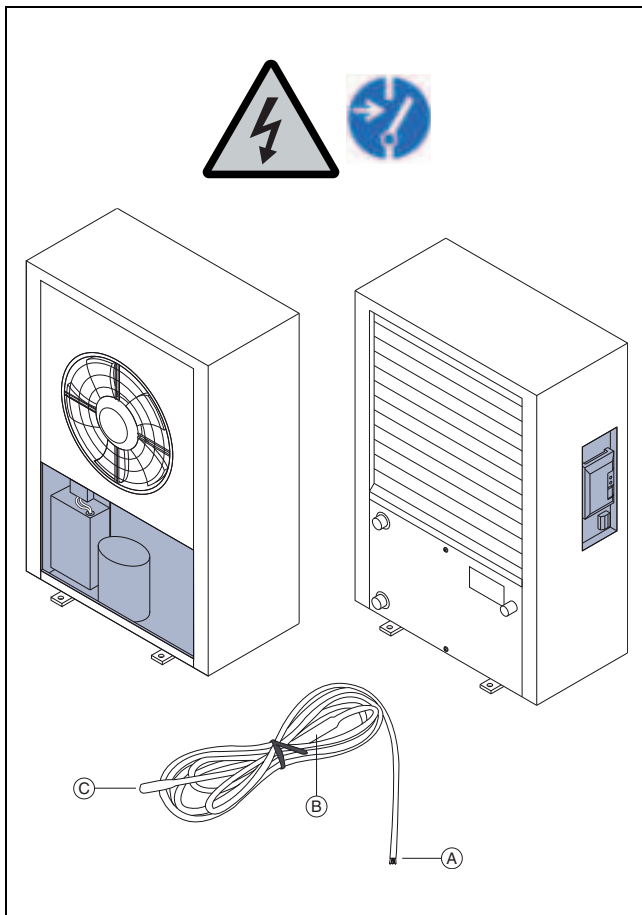

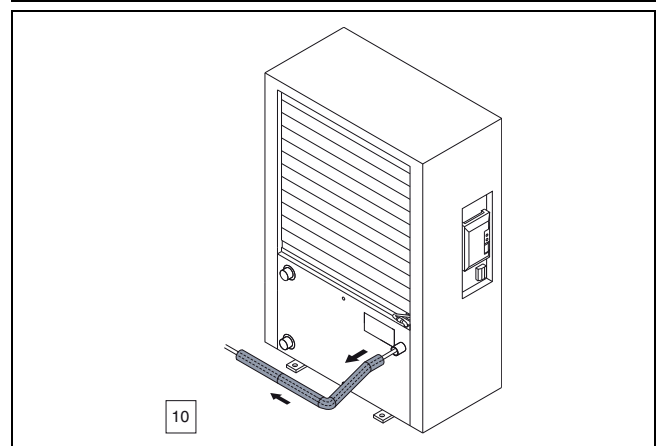
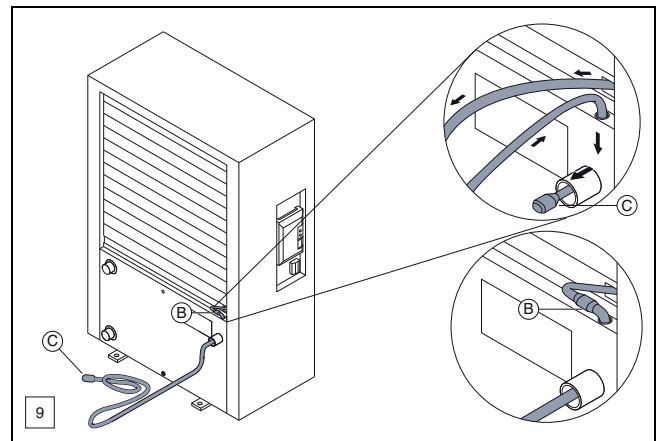
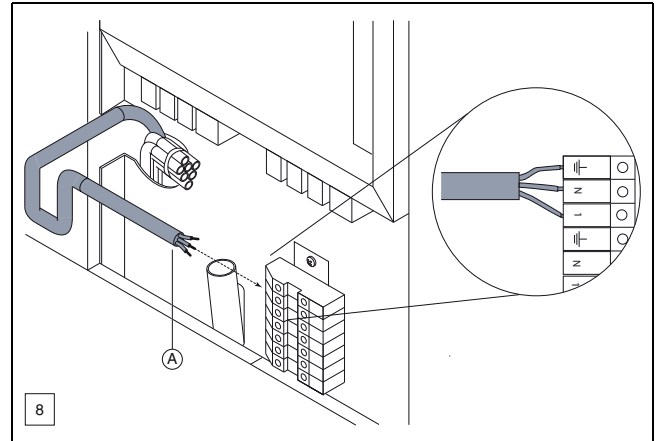
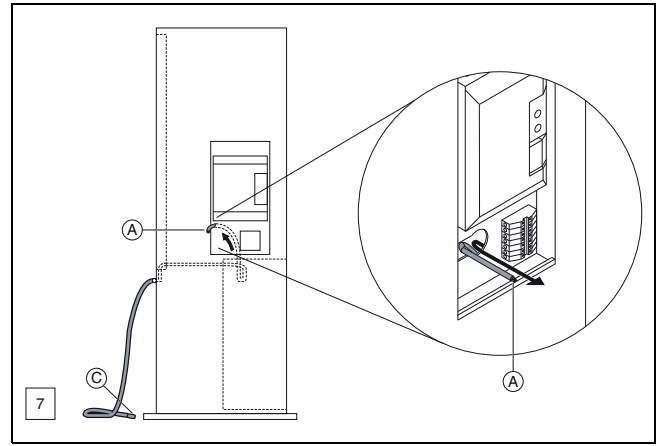
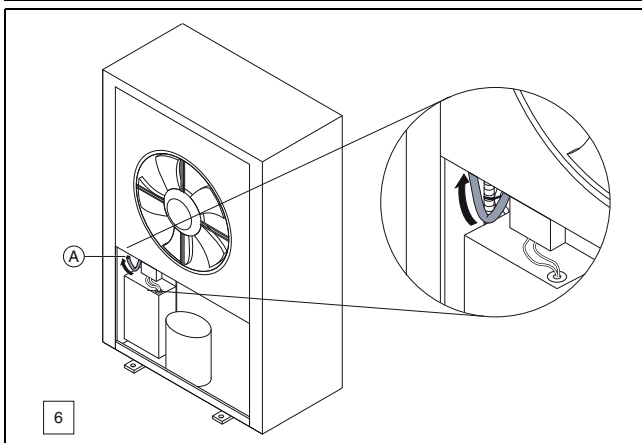
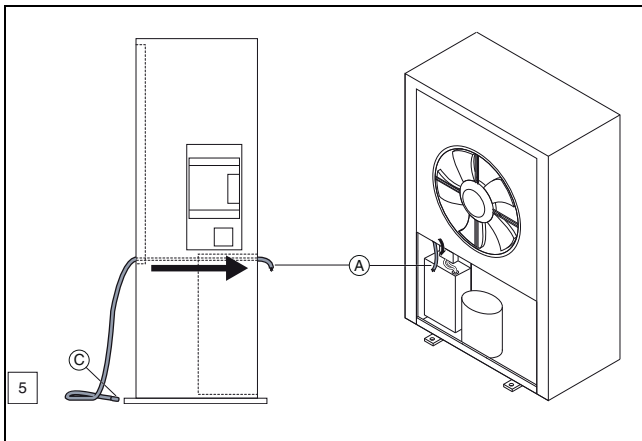
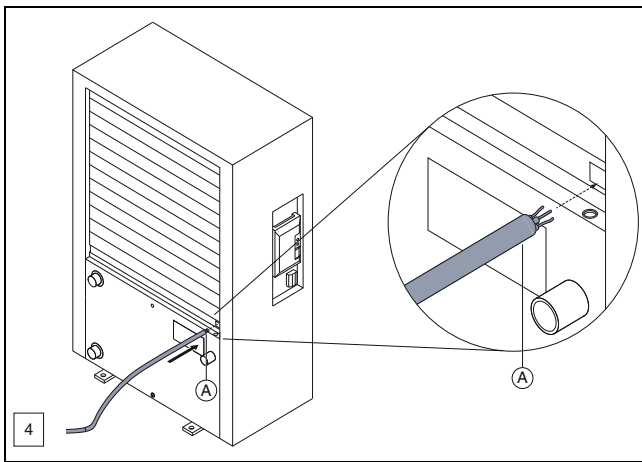
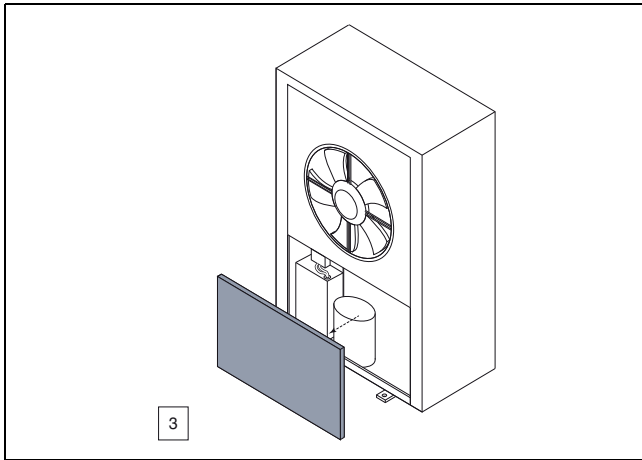

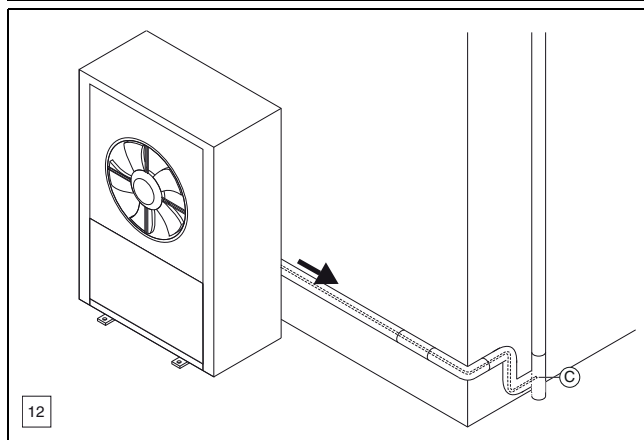
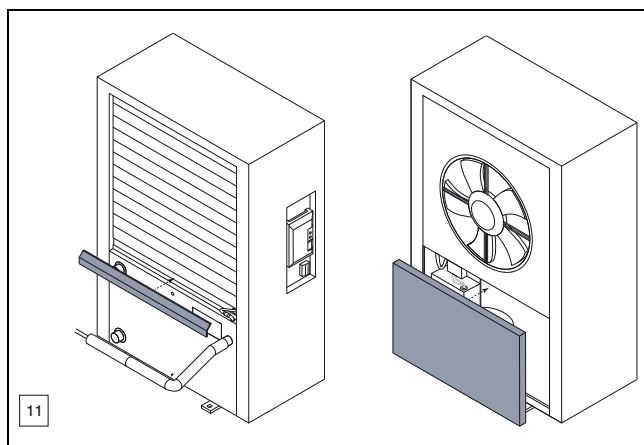

## 8 Environmental protection and disposal

Environmental protection is one of the fundamental company policies of the Bosch Group.

We regard quality of products, economy and environmental protection as equal objectives. Environmental protection laws and regulations are strictly adhered to.

To protect the environment, we use the best possible technology and materials taking economic aspects into account.

### Packaging

Where packaging is concerned, we participate in country-specific recycling processes that ensure optimum recycling.

All of our packaging materials are environmentally compatible and can be recycled.

### Used appliances

Used appliances contain valuable materials that can be recycled.

The various assemblies can be easily dismantled. Synthetic materials are marked accordingly. Assemblies can therefore be sorted by composition and passed on for recycling or disposal.

### Old electrical and electronic appliances



This symbol means that the product must not be disposed of with other waste, and instead must be taken to the waste collection points for treatment, collection, recycling and disposal.



The symbol is valid in countries where waste electrical and electronic equipment regulations apply, e.g. "European Directive 2012/19/EC on old electronic and electrical appliances". These regulations define the framework for the return and recycling of old electronic appliances that apply in each country.

As electronic devices may contain hazardous substances, it needs to be recycled responsibly in order to minimize any potential harm to the environment and human health. Furthermore, recycling of electronic scrap helps preserve natural resources.

For additional information on the environmentally compatible disposal of old electrical and electronic appliances, please contact the relevant local authorities, your household waste disposal service or the retailer where you purchased the product.

You can find more information here:

[www.weee.bosch-thermotechnology.com/](http://www.weee.bosch-thermotechnology.com/)

## 9 Technical information

### 9.1 Specifications – heat pump (alternating current)

	Unit	5 OR	7 OR
<b>Air/water operation</b>			
Power output with A -10/W35 <sup>1)</sup> , 100% compressor speed	kW	4.76	6.20
Power output with A -7/W35 <sup>1)</sup> , partial load	kW	4.24	5.66
COP with A -7/W35 <sup>1)</sup> , partial load		3.02	3.08
Modulation range with A -7/W35 <sup>1)</sup>	kW	1.5-5.0	1.9-6.8
Power output with A +2/W35 <sup>1)</sup> , 100% compressor speed	kW	5.48	7.29
Power output with A +2/W35, partial load	kW	2.53	2.54
COP with A +2/W35, partial load		4.25	4.25
Modulation range with A +2/W35	kW	1.9-5.5	2.5-7.3
Power output with A +7/W35 <sup>1)</sup> , partial load	kW	2.82	4.01
COP with A +7/W35 <sup>1)</sup> , partial load		5.01	5.01
Modulation range with A +7/W35 <sup>1)</sup>	kW	2.1-7.6	4.0-7.9
Cooling capacity with A 35/W7 <sup>1)</sup>	kW	4.44	5.66
EER with A 35/W7 <sup>1)</sup>		2.42	2.36
Cooling capacity with A 35/W18 <sup>1)</sup>	kW	6.15	7.39
EER with A 35/W18 <sup>1)</sup>		2.98	2.86
<b>Electrical details</b>			
Power supply		230 V 1N AC 50 Hz	230 V 1N AC 50 Hz
Protection index		IP X4	IP X4
Fuse rating for supplying the heat pump directly via the building connection <sup>2)</sup>	A	16	16
Maximum power consumption	kW	3.2	3.6
<b>Heat transfer medium</b>			
Minimum flow	l/s	0.33	0.43
Internal pressure reduction	kPa	7.8	10.5
<b>Air and noise generation</b>			
Max. fan motor output (DC transformer)	W	240	240
Maximum air current	m <sup>3</sup> /h	3400	3400
Sound pressure level with a clearance of 1 m, load point according to 2013/811/EU	dB(A)	42	42
Sound Power <sup>3)</sup>	dB(A)	50	50
Max. sound power A7/W55	dB(A)	54	55
Max. sound power "quiet operation" A7/W55	dB(A)	49	51
Max. sound power A7/W35	dB(A)	55	55
Max. sound power "quiet operation" A7/W35	dB(A)	47	48
Max. sound power incl. tonality	dB(A)	53 + 3 <sup>4)</sup>	55 + 3 <sup>4)</sup>
Max. sound power incl. tonality "quiet operation"	dB(A)	49 + 0 <sup>4)</sup>	51 + 0 <sup>4)</sup>
<b>General details</b>			
Refrigerant <sup>5)</sup>		R410A	R410A
Refrigerant charge	kg	1.75	2.35
CO <sub>2</sub> (e)	Tonne	3.65	4.91
Maximum temperature of flow, heat pump only	°C	62	62
Installation altitude above sea level		up to 2000 m above sea level	
Dimensions (W x H x D)	mm	940x1380x600	940x1380x600
Weight without walls and top cover	kg	89	96
Weight with walls and top cover	kg	113	120

1) Performance data in accordance with EN 14511

2) Fuse class gL/C

3) Sound power level in accordance with EN 12102

4) Tonality

5) GWP100 = 2088

Table 10 Specifications – heat pump (alternating current)

Detailed sound pressure level (max.) 5 OR													
	Space	m	1	2	3	4	5	6	8	10	12	14	16
Day	Q=2 <sup>1)</sup>	dB (A)	48	42	38	36	34	32	30	28	26	25	24
	Q=4 <sup>2)</sup>	dB (A)	51	45	41	39	37	35	33	31	29	28	27
Night	Q=2 <sup>1)</sup>	dB (A)	41	35	31	29	27	25	23	21	19	18	17
	Q=4 <sup>2)</sup>	dB (A)	44	38	34	32	30	28	26	24	22	21	20

  

Detailed sound pressure level (max.) 7 OR													
	Space	m	1	2	3	4	5	6	8	10	12	14	16
Day	Q=2 <sup>1)</sup>	dB (A)	50	44	40	38	36	34	32	30	28	27	26
	Q=4 <sup>2)</sup>	dB (A)	53	47	43	41	39	37	35	33	31	30	29
Night	Q=2 <sup>1)</sup>	dB (A)	43	37	33	31	29	27	25	23	21	20	19
	Q=4 <sup>2)</sup>	dB (A)	46	40	36	34	32	30	28	26	24	23	22

1) No wall within a distance of 3m

2) Heat pump near the wall

Table 11 Detailed sound pressure level, heat pump (alternating current)

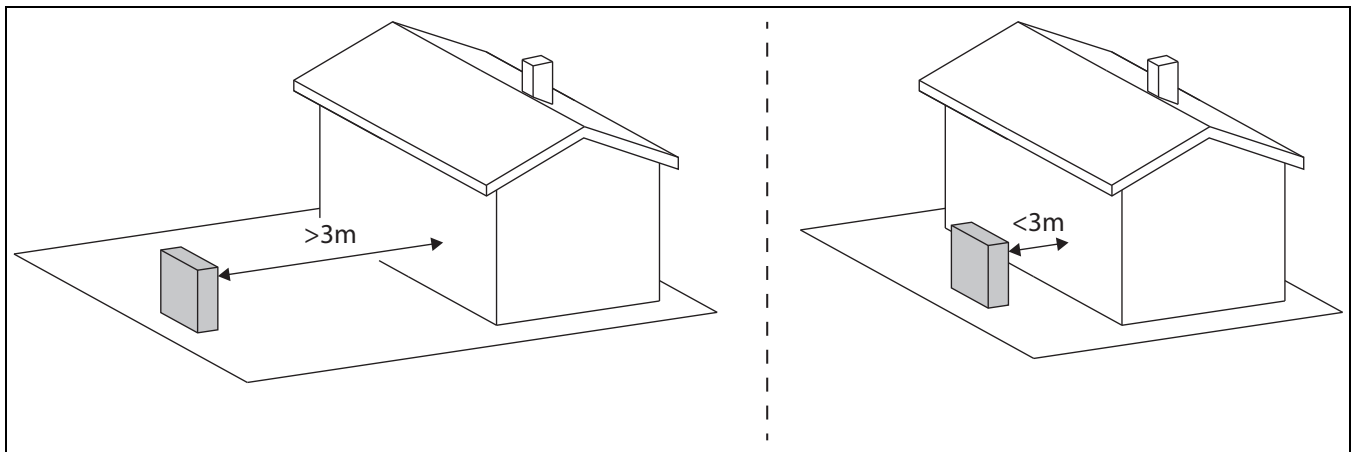

## 9.2 Operating range of heat pump without auxiliary heater



The heat pump switches off at approx.  $-20\text{ }^{\circ}\text{C}$  or  $+35\text{ }^{\circ}\text{C}$ . The indoor unit or an external heat source then take over the heating and DHW heating. The heat pump restarts if the outdoor temperature exceeds roughly  $-17\text{ }^{\circ}\text{C}$  or falls below  $+32\text{ }^{\circ}\text{C}$ . In cooling mode the heat pump switches off at roughly  $+45\text{ }^{\circ}\text{C}$  and restarts at roughly  $+42\text{ }^{\circ}\text{C}$ .

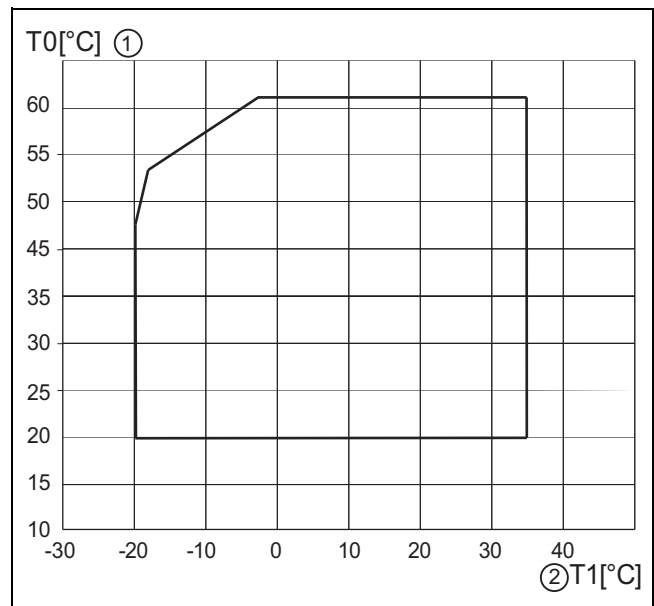

Fig. 20 Heat pump without auxiliary heater

- [1] Maximum flow temperature (T0)
- [2] Outdoor temperature (T1)

**9.3 Refrigerant circuit**

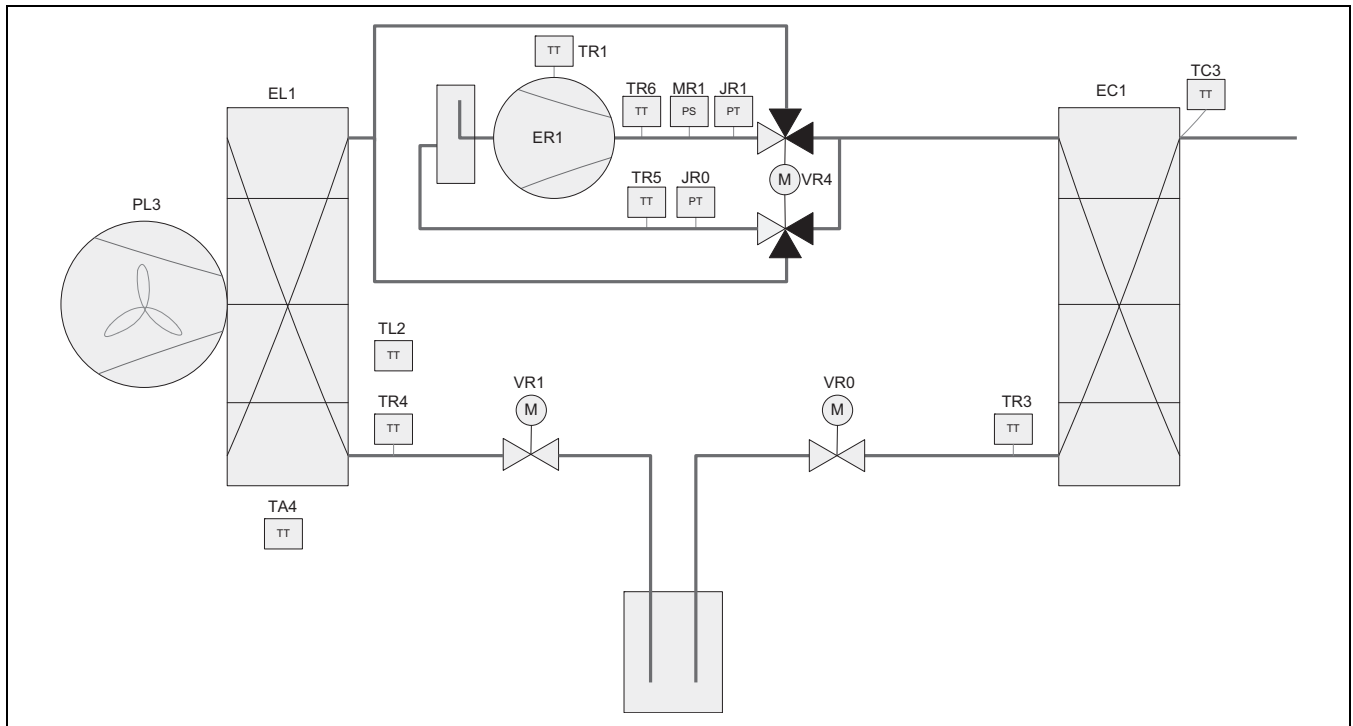

Fig. 21 Refrigerant circuit

- [EC1] Heat exchanger (condenser)
- [EL1] Evaporator
- [ER1] Compressor
- [JR0] Low pressure sensor
- [JR1] High pressure sensor
- [MR1] High pressure switch
- [PL3] Fan
- [TA4] Temperature sensor, drip pan
- [TC3] Temperature sensor, heat transfer medium outlet
- [TL2] Temperature sensor, air intake
- [TR1] Temperature sensor, compressor
- [TR3] Temperature sensor, condenser return (liquid), heating mode
- [TR4] Temperature sensor, evaporator return (liquid), cooling mode
- [TR5] Temperature sensor, suction gas
- [TR6] Temperature sensor hot gas
- [VR0] Electronic expansion valve 2 (condenser)
- [VR1] Electronic expansion valve 2 (evaporator)
- [VR4] Four-way valve

## 9.4 Wiring diagram

### 9.4.1 Wiring diagram for transformer, alternating current

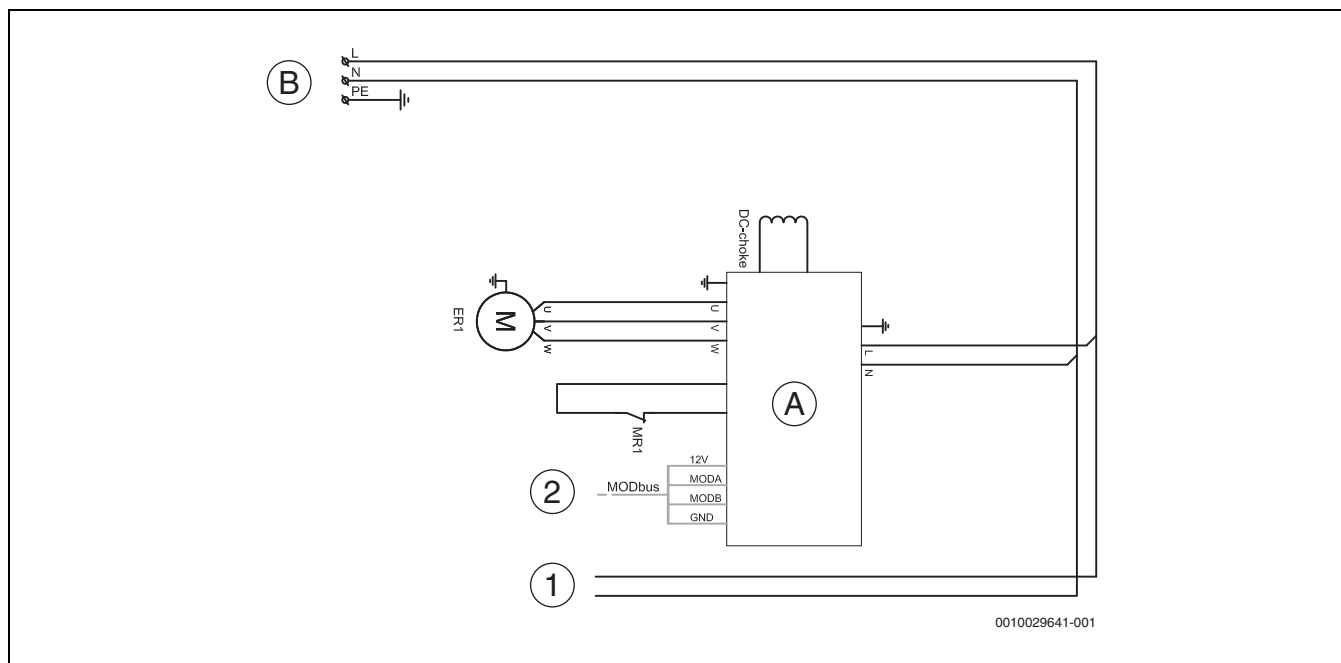

Fig. 22 Wiring diagram for transformer, alternating current / three-phase current

- [ER1] Compressor
- [MR1] High pressure switch
- [A] Inverter
- [B] Mains voltage 230 V 1N~
- [1] Power supply of I/O module
- [2] MOD-BUS to I/O module

**9.4.2 Wiring diagram for I/O module**

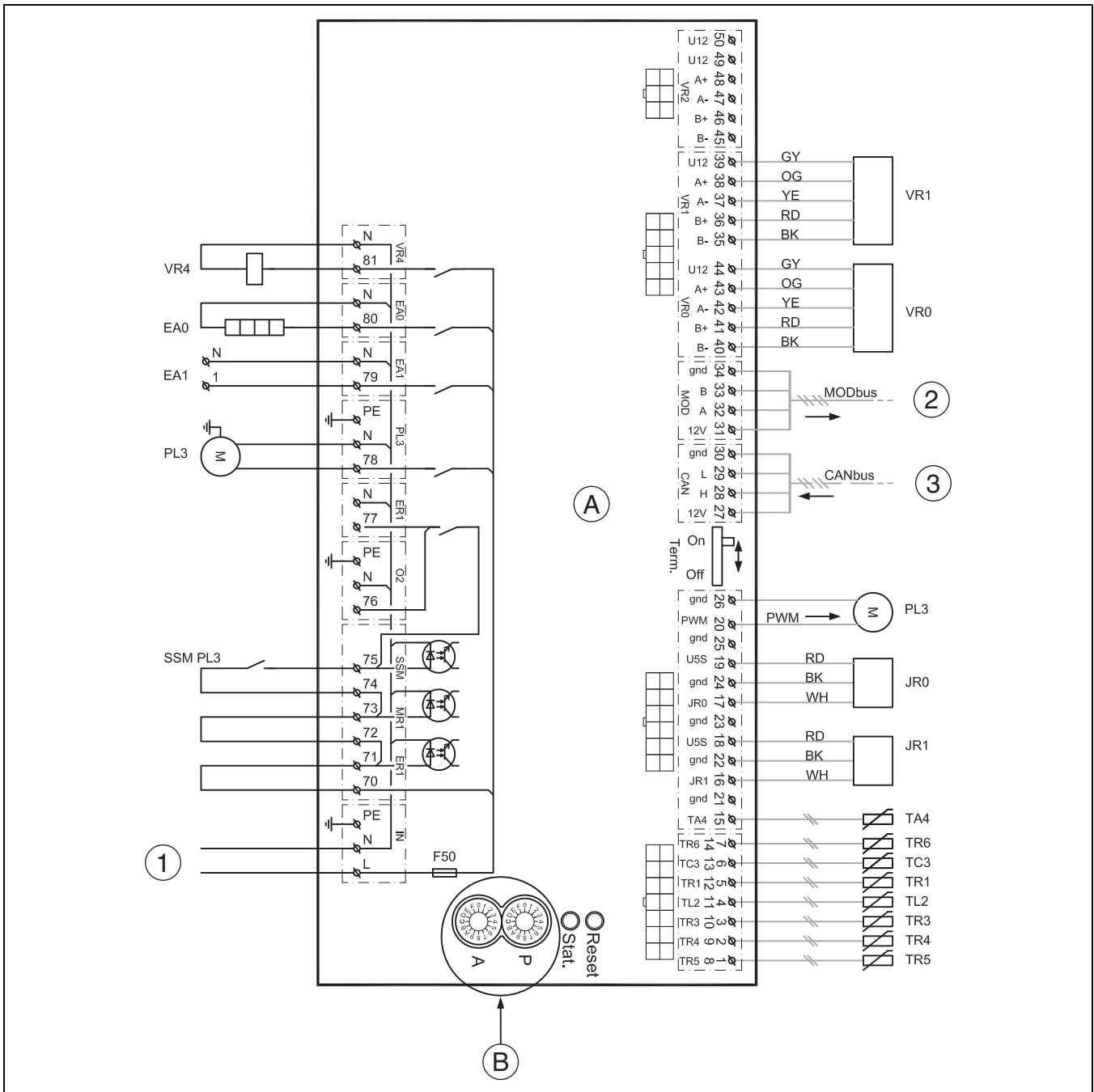

Fig. 23 Wiring diagram for I/O module

- |       |   |     |   |
|-------|---|-----|---|
| [JR0] | Pressure sensor low                             | [A] | I/O module  |
| [JR1] | Pressure sensor high                            | [B] | P7=heat pump 5 OR, 1N~<br>P8=heat pump 7 OR, 1N~<br>A0=standard |
| [PL3] | Fan, pulse width modulation signal              | [1] | 230 V~ operating voltage  |
| [TA4] | Drip tray temperature sensor                    | [2] | MOD-BUS from transformer  |
| [TC3] | Temperature sensor, heat transfer medium outlet | [3] | CAN-BUS from installation module of indoor unit                 |
| [TL2] | Temperature sensor at air inlet                 |     |   |
| [TR1] | Temperature sensor, compressor                  |     |   |
| [TR3] | Temperature sensor at condenser return          |     |   |
| [TR5] | Suction gas temperature sensor                  |     |   |
| [TR6] | Temperature sensor hot gas                      |     |   |
| [VR0] | Electronic expansion valve 1                    |     |   |
| [VR1] | Electronic expansion valve 2                    |     |   |
| [EA0] | Heater for drip pan                             |     |   |
| [EA1] | Heating cable (accessory)                       |     |   |
| [F50] | Fuse 6.3 A                                      |     |   |
| [PL3] | Fan   |     |   |
| [SSM] | Motor protection in the fan                     |     |   |
| [VR4] | Four-way valve                                  |     |   |

### 9.4.3 Measurements for temperature sensor

°C	Ωr..	°C	Ωr...	°C	Ωr...
-40	154300	5	11900	50	1696
-35	111700	10	9330	55	1405
-30	81700	15	7370	60	1170
-25	60400	20	5870	65	980
-20	45100	25	4700	70	824
-15	33950	30	3790	75	696
-10	25800	35	3070	80	590
-5	19770	40	2510	85	503
± 0	15280	45	2055	90	430

Table 12 Sensor TA4, TL2, TR4, TR5

°C	Ω	°C	Ω	°C	Ω	°C	Ω
-20	96358	15	15699	50	3605	85	1070
-15	72510	20	12488	55	2989	90	915
-10	55054	25	10001	60	2490	-	-
-5	42162	30	8060	65	2084	-	-
± 0	32556	35	6536	70	1753	-	-
5	25339	40	5331	75	1480	-	-
10	19872	45	4372	80	1256	-	-

Table 13 Sensor TC3, TR3

°C	Ω	°C	Ω	°C	Ω	°C	Ω
-20	198500	15	31540	50	6899	85	2123
-15	148600	20	25030	55	5937	90	1816
-10	112400	25	20000	60	4943	95	1559
-5	85790	30	16090	65	4137	100	1344
± 0	66050	35	13030	70	3478	105	1162
5	51220	40	10610	75	2938	110	1009
10	40040	45	8697	80	2492	1156	879

Table 14 Sensor TR1, TR6

### 9.5 Information on refrigerant

This device contains **fluorinated greenhouse gases** as refrigerant. The device is hermetically sealed. You will find the information on the refrigerant according to the Regulation (EU) No 517/2014 on fluorinated greenhouse gases in the operating instructions of the device.



Information for the installer: If you refill refrigerant, enter the additional charge size and the total charge size of the refrigerant in the table "information on refrigerant" of the operating instructions.







TECHNICAL SUPPORT: 0330 123 3366  
RENEWABLE SUPPORT: 0330 123 9229  
CONTROLS AND CONNECTIVITY TEAM: 0330 123 3641  
APPOINTMENTS: 0330 123 9339  
SPARES: 0330 123 9779  
LITERATURE: 0330 123 9119  
TRAINING: 0330 123 0166  
SALES: 0330 123 9669

Bosch Thermotechnology Ltd.  
Cotswold Way, Warndon  
Worcester WR4 9SW  
United Kingdom  
Tel. 0330 123 9559  
[worcester-bosch.co.uk](http://worcester-bosch.co.uk)

