

The Siemens logo is displayed in a bold, teal, sans-serif font.

*Ingenuity for life*

A background image of an industrial plant with a digital overlay. The overlay includes a glowing hexagonal icon with a gear and a factory, vertical columns of binary code (0s and 1s), and blue light trails. A worker in a yellow safety vest and white hard hat is visible in the background.

## Empower your data value with COMOS – Modularized Engineering

[siemens.com/comos-modularized-engineering](https://www.siemens.com/comos-modularized-engineering)

### Accelerated processes and assured results – from digital proposal creation to plant delivery

Creating competitive proposals is one of the economic success factors in the plant and project business. The proposal process ties up resources and at the same time, plant projects are becoming increasingly complex, schedules are becoming tighter, and customers still expect top quality. These challenges apply to both the proposal phase and engineering itself. IT-supported commercial and technical systems can help to overcome these challenges. Most OEMs (Original Equipment Manufacturers) and EPCs (Engineering, Procurement, and Construction) employ diverse solutions to accomplish this.

**Inefficiency, system discontinuities, and analog procedures have no place in the age of digitalization – it is time to redefine engineering and proposal processes! Get to know the COMOS-based approach of modularized engineering and a new approach to proposal management!**



Reduce time between construction and production, optimize time-to-market, and become more competitive

Based on the principle of a cross-discipline configurator, the COMOS plant engineering software helps to

- optimize use of existing expertise
- standardize engineering processes
- shorten proposal processes
- increase proposal quality significantly!



### **Modularized engineering instead of copy-plant**

When planning new projects, it is still common in plant engineering to use existing, planned or similar projects or templates via the „copy-plant concept“. Therewith a number of problems may occur:

- Each time an existing project is copied, there is the risk of copying existing errors into the new project (e.g. structural or layout errors).
- Unintended transfer of original project framework conditions, such as country-specific regulations, climatic conditions, etc. results in the risk of so-called over or under engineering. That means: A plant which is designed for extreme climate conditions, for instance, may be designed much too generously for use in more moderate climatic conditions or vice versa. This can often result in high project and implementation costs and expensive additional work on the construction site.
- Using simple templates that cannot be controlled or expanded with modular rules prevents optimization of the range of templates from the outset. Intelligent modules provide much greater flexibility, can be used for different projects and fields, and prevent an uncontrolled increase in the number of templates.

Competitive and precise proposals for your customers

**Modularized engineering prevents errors.  
Use optioneering and digital proposal management  
based on COMOS!**

## Modularized engineering from customer inquiry to detailed engineering

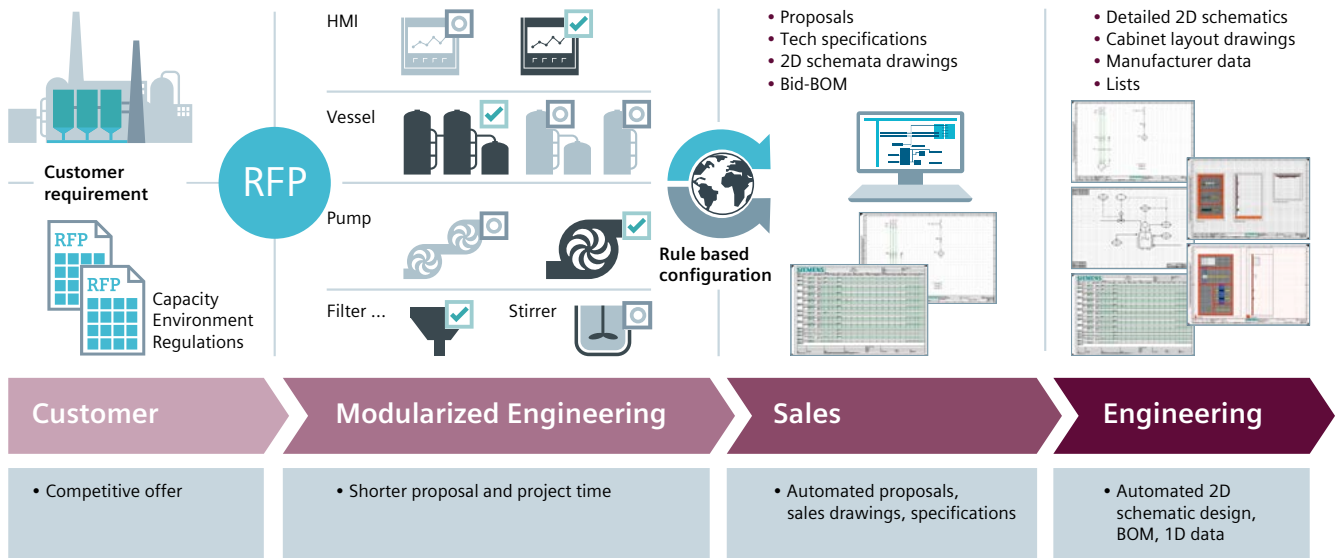

Graphical editor helps generate rules with ease.

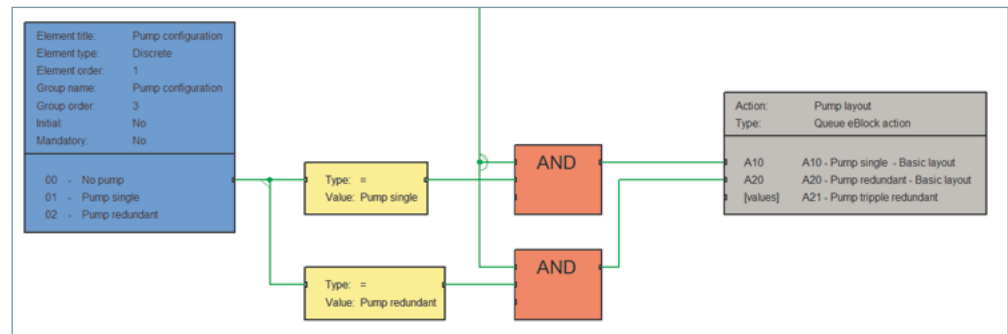

### The configurator as the basis for efficient processes

COMOS saves and manages all components needed for engineering and quotation in a central database – from service packages to plant devices. Knowledge from a wide range of different disciplines (like process or electrical engineering) is brought together here in an interdisciplinary way. Using project templates, all individual components are expanded with custom variations or options using a configurator and given rules. The rules define, for instance, interdependencies between the components. Or they specify what components need to be considered in the proposal using selectable project parameters (country-specific or environmental regulations, climate conditions, etc.). The rules are defined in a graphical editor. Instead of programming individual sets of rules with a lot of effort, they can now be created quickly and easily using drag-and-drop!

- Intelligent modules ensure greater levels of flexibility and accuracy within proposal and engineering works.
- Proposal processes use fewer resources and are faster.
- After the order is received, large parts of the basic engineering are already completed.
- The rule-based, accurate layout of components prevents over-/under-engineering.
- Official regulations are reliably met every time.
- Reduce your NCC – non-conformity costs!

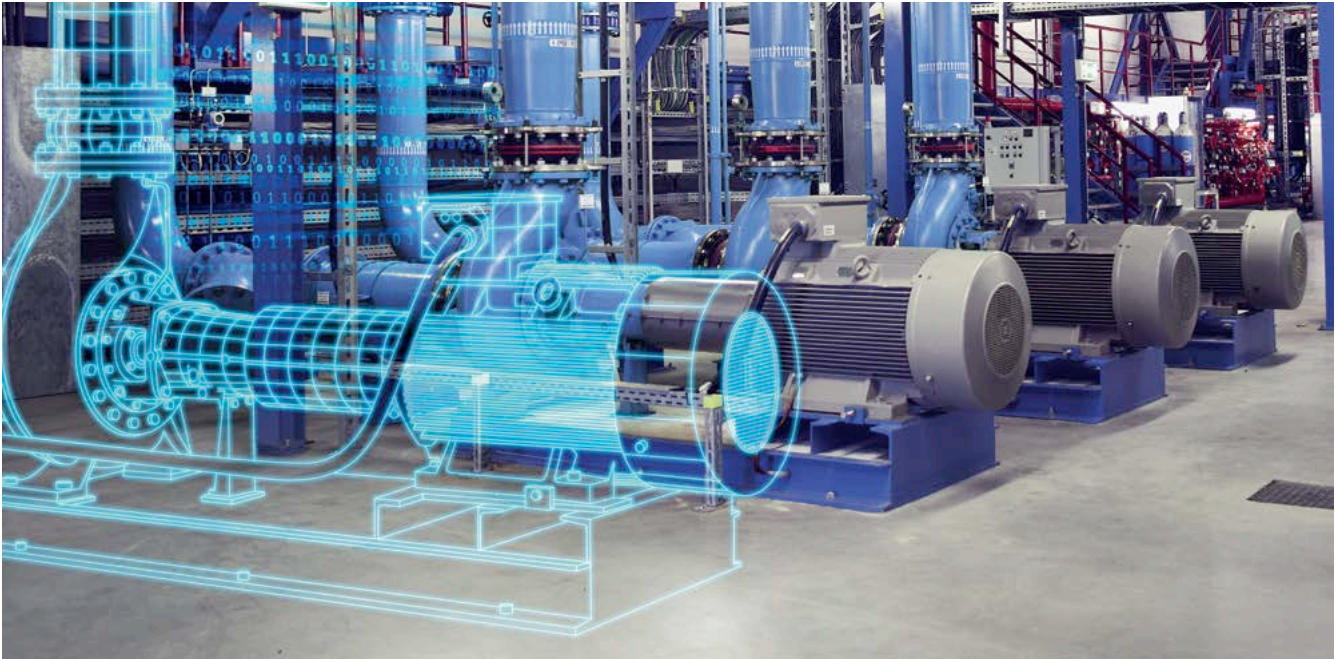

**Profit from benefits that extend far beyond the proposal phase!**

Modularized engineering with COMOS is not only the basis for systematic and accelerated proposal processes – it also generates automatic time and cost benefits in basic and detail engineering. See the possibilities and benefits of modularized engineering with COMOS for yourself:

Option-based plant design to accelerate processes and increase quality – from customer inquiry to plant delivery

- Rule-based planning of new projects prevents transfer of errors from previous projects.
- A central database brings together knowledge from different disciplines: unrestricted access to all prior project experience for the participants in each new project.
- Systematic and structured feedback of knowledge from each project acts as the basis for continual accumulation of expertise for future work.
- Standardized modules help you react much more flexibly to a customer's demands: changes can be implemented faster and without errors.
- Trust in optioneering: simply select the corresponding components from the model kit that fit the technical specifications (such as containers, filters, etc.).
- Sales and project documentation is updated automatically.
- Integrate your interdisciplinary engineering processes via COMOS' centralized data model, saving time and money!
- Rules in the configurator are shown as graphically generated elements and are therefore easier to recognize and operate than traditional programming that takes up resources and time.
- Especially at OEMs, variations in plant/machine conditions can quickly increase the complexity of a project. Standardized templates help reduce this complexity largely.

© Siemens AG 08.2018  
 Subject to change without notice  
 PDPA-B90006-00-7600  
 Accelerated processes and assured results  
 from digital proposal creation to plant delivery  
 Produced in Germany

The information provided in this flyer contains descriptions or characteristics of performance which in case of actual use do not always apply as described or which may change as a result of further development of the products. An obligation to provide the respective characteristics shall only exist if expressly agreed in the terms of contract. Availability and technical specifications are subject to change without prior notice. All product designations may be trademarks or product names of Siemens AG or supplier companies whose use by third parties for their own purposes could violate the rights of the owners.

**Security information**

In order to protect plants, systems, machines and networks against cyber threats, it is necessary to implement – and continuously maintain – a holistic, state-of-the-art industrial security concept. Siemens' products and solutions only form one element of such a concept. For more information about industrial security, please visit <http://siemens.com/industrialsecurity>.