

***TM 1-1520-240-CL**

TECHNICAL MANUAL

**Operator's and
Crewmember's Checklist**

**ARMY CH-47D
HELICOPTER
(EIC: RCD)**

*This manual supersedes TM 55-1520-240-CL, dated 30 April 1992, including all changes

DISTRIBUTION STATEMENT A: Approved for public release; distribution is unlimited.

**HEADQUARTERS
DEPARTMENT OF THE ARMY
31 January 2003**

TM 1-1520-240-CL

GENERAL INFORMATION AND SCOPE

SCOPE. This checklist contains the operator's and crew member's checks to be accomplished during normal and emergency operations.

GENERAL INFORMATION. This checklist consists of three parts: normal procedures, emergency procedures, and performance data. Normal procedures consist of the procedures required for normal flight. Emergency procedures are subdivided into 10 classifications as follows: engine, rotor/transmission/drive, fire, fuel, electrical, hydraulic, landing and ditching, flight controls, and mission equipment, as applicable. Performance data consists of performance checks.

NOTE

This checklist does not replace the amplified version of the procedures in the operator's manual (TM 1-1520-240-10), but is a condensed version of each procedure.

Normal Procedures Pages. The contents of the normal procedures of this manual are a condensation of the amplified checklist appearing in the normal procedures or crew duties portion of the applicable operator's manual.

Emergency Procedure Pages. The requirements in this section of the condensed checklist (CL) are identical to those for the normal procedures, except that the information is drawn from the amplified checks in the emergency procedures portion of the operator's manual. The emergency requirements are subdivided into 10 classifications listed above.

TM 1-1520-240-CL

Symbols Preceding Numbered Steps.

- F Indicates flight engineer function or response.
- O Indicates "If Installed."
- ★ Indicates a detailed procedure of this step is included in the Performance Checks section, located at the back of the checklist.
- * Indicates performance of step is mandatory before each flight or "Thru-Flights."
- ④ Indicates copilot duties.

Immediate action emergency steps are underlined.

REPORTING ERRORS AND RECOMMENDING IMPROVEMENTS

You can help improve this manual. If you find any mistakes or if you know of a way to improve the procedures, please let us know. Mail your letter, DA Form 2028 (Recommended Changes to Publications and Blank Forms) located in the back of the applicable Aircraft Operators manual direct to: Commander, U.S. Army Aviation and Missile Command, ATTN: AMSAM-MMC-MA-NP, Redstone Arsenal, AL 35898-5230. You may also submit your recommended changes by e-mail directly to 2028@redstone.army.mil or by fax (256) 842-6546/DSN 788-6546. A reply will be furnished directly to you. Instructions for sending an electronic 2028 may be found at the back of the Aircraft Operator's manual.

TM 1-1520-240-CL

BEFORE EXTERIOR CHECK

- * 1. Publications — Check.
- * 2. Ignition lock switch — On.
- 3. **712** EMERGENCY POWER panel — Check.
- 4. **712** Topping stops — Check stowed.
- 5. Cockpit area — Check.
- * 6. Forward transmission — Check.
- 7. Forward transmission oil cooler inlet — Check.
- 8. Fuel sample — Check first flight of day.

INTERIOR CHECK

FORWARD CABIN

- 1. Flight control closet — Check.
- 2. Heater Compartment — Check.
- 3. Emergency escape axe — Check.
- 4. Cabin door — Check.
- 5. Avionics equipment — Check.
- 6. Fire extinguisher — Check.
- 7. Cabin escape panel — Check.
- 8. Transformer-rectifier air intake screens — Check.
- 9. Seats, litters, first aid kits, cargo, and jettisonable cabin windows — Check.
- 10. Utility hatch door and lower rescue door — Check.
- 11. Center cargo hook — Check.
- 12. Forward, center, and aft cargo hook release lever — Check.
- 13. **714A** DECU's — Check.
- 14. EAPS Control boxes — Check.
- 15. ERFS installed — Check.
- ★○ 16. ERFS II installed — Check.

TM 1-1520-240-CL

AFT CABIN

1. Ramp — Check.
2. Engine fire extinguisher bottles— Check.
3. POWER STEERING MODULE — Check.
4. 714A P3 drain (right)— Check.
5. FUEL VALVE #2 ENGINE — Check OPEN.
6. FUEL VALVE CROSSFEED (right) — CLOSED.
7. HYD SYS FILL module — Check.
- * 8. APU start accumulators — Check.
- * 9. MAINTENANCE PANEL — Check.
- 10. AFT POS LIGHT switch — Set as required.
- 11. PWR MDL CHIP BURN-OFF — Check.
- * 12. Aft transmission — Check.
13. APU — Check.
14. EMERGENCY APU FLUID SHUT OFF VALVE— Check OPEN.
15. COMPASS FLUX VALVE — Check.
16. FUEL VALVE CROSSFEED (left) — Check CLOSED.
17. FUEL VALVE #1 ENGINE — Check OPEN.
18. 714A P3 drain (left)— Check.
19. Fire extinguisher — Check.
- 20. AN/ALE-47 Safety switch — Safety Pin Installed.

EXTERIOR CHECK

AFT CABIN

1. Position light — Check.
2. Right aft landing gear area — Check.
3. Vent and fluid drain lines — Check.

TM 1-1520-240-CL

RIGHT CABIN

1. NO. 2 Engine — Check.
2. Fuselage — Check.
- * 3. Fuel system — Check.
4. Position light — Check.
5. Forward landing gear area — Check.
6. Pressure refueling control panel — Check.
7. Static port — Check.
8. Right electrical compartment — Check.

FORWARD CABIN

1. Heater intake, exhaust, and combustor drain — Check.
2. Pilot's jettisonable door — Check.
3. Pilot's pedal area — Check.
4. Right AFCS yaw ports — Check.
5. Pitot tubes — Check.
6. Antennas — Check.
7. Searchlights — Check.
8. Windshield and wipers — Check.
9. Left AFCS yaw ports — Check.
10. Copilot's pedal area — Check.
11. Copilot's jettisonable door — Check.

LEFT CABIN

1. Fuselage — Check.
2. Left electrical compartment — Check.
3. Forward landing gear area — Check.
4. Forward and aft cargo hooks — Check.
5. Lower anti-collision light — Check condition.
6. Static port — Check.
- * 7. Fuel system — Check.

TM 1-1520-240-CL

- 8. ERFS II Installed. Overboard Drain Outlets — Check.
- 9. ERFS II Installed. Overboard Vent Outlets — Check.
- 10. NO. 1 Engine — Check.
- 11. Left aft landing gear area — Check.
- 12. Vent and fluid drain lines — Check.
- 13. M-130 Safety Pin — Installed.

TOP OF FUSELAGE

- * 1. No. 2 engine — Check.
- 2. Anti-collision light and formation lights — Check.
- * 3. AFT rotor (right side) — Check.
- 4. Droop stop shrouds — Check.
- 5. Upper boost actuator — Check.
- ★ 6. Hydraulic compartment — Check.
- * 7. Combining transmission area — Check.
- * 8. Aft rotor (left side) — Check.
- 9. Droop stop shrouds — Check.
- 10. Upper boost actuator — Check.
- * 11. No. 1 engine — Check.
- 12. Drive shaft area — Check.
- * 13. Forward rotor (right side) — Check.
- 14. Forward transmission oil cooler inlet — Check for obstructions.
- 15. Upper boost actuators — Check.
- 16. Forward transmission — Check.
- ★ 17. Hydraulic compartment — Check.
- * 18. Forward rotor (left side) — Check.
- 19. Brake accumulator pressure — Check.
- * 20. Pylon fairings, work platforms, and inspection panels — Check.

TM 1-1520-240-CL

- * 21. Top fuselage — Check.
- 22. Remove the fuel vent covers (3) (if installed) before using ERFs.

WALK AROUND CHECK AND SECURITY BRIEF

- * 1. All access doors — Check.
- * 2. Tiedowns, locking devices, covers, and ground cables — Removed and secured.
- * 3. Cockpit, Forward Transmission, and Forward Cabin area sound proofing — Installed.
- * 4. Crew/passenger briefing — Complete as required.

BEFORE STARTING ENGINES

- 1. Pedal adjustment — Matched.
- 2. Shoulder harness locks — Check operation and leave unlocked.
- * 3. No. 1 and No. 2 PDP's — Check.
- ★* 4. Overhead switches and controls — As required.
- 5. FIRE PULL handles — In.
- 6. AGENT DISCH switch — Check.
- * 7. XMSN OIL PRESS switch — SCAN.
- * 8. XMSN OIL TEMP switch — SCAN.
- * 9. VGI switches — NORM.
- 10. CYCLIC TRIM switch — AUTO.
- * 11. AFCS SYSTEM SEL switch — OFF.
- * 12. M-130 or AN/ALE-47 — SAFE or OFF.
- 13. Avionics equipment — OFF; set as required.
- 14. HUD — OFF.
- 15. **712** EMERG ENG TRIM switches — AUTO.
- 16. SWIVEL switch — LOCK.

TM 1-1520-240-CL

STARTING ENGINES

- * ① BATT switch — ON.
- 2. CAUTION LT TEST switch — TEST.
- 3. Clocks — Running. Set as required.
- F** ④ TROOP WARN ALARM and JUMP LTS — As required.
- F*** 5. Fire guard Posted — APU clear to start.
- ★*** ⑥ APU — Start.
- * ⑦ APU GEN switch — ON.
- F*** ⑧ PWR XFER 1 and 2 switches — ON. Check HYD FLT CONTR caution capsules out.
- F*** 9. MAINTENANCE PANEL — Check.
- * 10. Avionics — ON as required..
- O** 11. HUD — On as required.
- ★F** 12. CARGO HOOKS HOIST/WINCH — Check operation as required.
- F** 13. ANTI-ICE system — Check as required.
- 14. SLT-FIL switches — Check and set as required.
- * 15. PARKING BRAKE — Set.
- 16. CRUISE GUIDE indicator — Check.
- F*** 17. Altimeters — Set and check.
- 18. FIRE DETR switch — TEST.
- * 19. Fuel quantity — Check as required.
- * 20. Cyclic trim indicators — Check GND position.
- F*** 21. Rotor blades — Check position.
- * 22. AFCS SYSTEM SEL switch — Check.
- ★F*** 23. Flight control travel and hydraulics — Check. Return to neutral.
- 24. Avionics — Perform operational check and set as required.

TM 1-1520-240-CL

- 25. HUD — program as required.
- ★F* (26). 714A DECU PRESTART BIT — Perform.
- 27. 712 ENGINE BEEP TRIM switch (NO. 1 & 2) — DECREASE for 8 seconds.
- * 28. Ignition Lock switch — ON.
- F* 29. Area — Clear for start.
- * (30). EAPS Fan switches — ON (delay 10-15 seconds between turning on No. 1 and No. 2).
- ★F* (31). 712 First engine — Start.
- ★F* (32). 714A First engine — Start.
- ★F* (33). Second engine — Start same as first.
- * 34. Transmission oil pressures — Check.
- * (35). ENG COND levers — FLT.
- * 36. 712 RRPM — Set as required/ 714A RRPM — Check 100% ± 1%.
- F* 37. Fluid drain lines — Check.
- * (38). GEN 1 and 2 switches — ON. 712 No. 1 & No. 2 GEN OFF 714A GEN No. 1 & No. 2 caution capsules out (delay 2 seconds between 1 and 2).
- * (39). APU GEN switch — OFF.
- ★F* (40). 714A DECU START BIT — Perform.
- * (41). PWR XFER 1 and 2 switches — OFF.
- * (42). APU switch — OFF. APU ON caution/advisory capsule out.
- * 43. Systems — Check normal.
- * (44). Transponder — STBY.

ENGINE GROUND OPERATION

- ★ (1) FUEL PUMP and XFEED — Check operation.
- F* (2) FUEL CONTR switches — Set.
 - 3. VGI switches — As required
 - * 4. Flight instruments — Check.
- (5) 712 Emergency engine trim system — Check.
- ★ (6) 714A FADEC system — Reversionary system check (First flight of day)
 - 7. Radar altimeters — Check and set.
- ★* (8) Transponder — Check and set.
 - * 9. Navigation Set DGNS — ON, as required. Perform operational check as required.

BEFORE TAXI

- * 1. SWIVEL switch — As required.
- * 2. AFCS switch — As required.
- * 3. Cyclic trim indicators — Check GND position.
- FO* 4. M-130 or AN/ALE-47 safety pin — Remove and stow.
- F* 5. Chocks — Removed and secured.
- F* 6. Ramp and cabin door — As required.
- F* 7. Crew, passengers, and mission equipment — Check ready for taxi.
- O* 8. HUD — Adjust as necessary.
- F* 9. Taxi director and blade watchers — Positioned.
- * 10. PARKING BRAKE — As required.

TAXIING CHECK

- * 1. Brakes — Check pilot's and copilot's as required.
- * 2. POWER STEERING — Check as required.

TM 1-1520-240-CL

BEFORE HOVER

- * 1. SWIVEL switch — LOCK.
- * 2. AFCS control panel — Set as required.
- F 3. 712 HIT/714A PAT check — Perform first flight of day (may be deferred).
- * 4. RRPM — Set as required.

HOVER CHECK

- 1. Flight controls — Check.
- 2. Systems instruments — Check.
- 3. Flight instruments — Check.
- 4. LCTS — Check retracted.
- F 5. GROUND CONTACT indicating lights — Check both off.
- 6. AFCS — Check. (First flight of day.)
- F 7. 712 HIT/714A PAT — Perform as required.
- 8. Power Check — Perform as required.

BEFORE TAKEOFF

- * 1. Systems — Check.
- * 2. PARKING BRAKE — As required.
- * 3. AFCS SYSTEM SEL switch — As required.
- * 4. CYCLIC TRIM switch — Check.
- * 5. SWIVEL switch — LOCK.
- * 6. Transponder — As required.
- F* 7. Crew, passengers, and mission equipment — Check.

CRUISE CHECK

- * 1. AFCS Control Panel — As required.
- F* 2. Ramp area — Check every 30 minutes.
- * 3. Fuel consumption — Check.

TM 1-1520-240-CL

BEFORE LANDING

- * 1. Systems — Check
- * 2. PARKING BRAKE — As required.
- * 3. AFCS control panel — Check.
- F*** 4. Crew, passenger, and mission equipment — Check.
- * 5. Searchlight — As required.

AFTER LANDING

- 1. Flight Controls — Neutralize.
- 2. Cyclic trim indicators — Check GND indication.
- F** 3. Ground Contact lights — Check both ON.
- 4. AFCS SYSTEM SEL switch — As required.
- 5. SWIVEL switch — As required.
- 6. Transponder — As required.
- 7. Searchlight — As required.
- 8. ANTI-ICE switches — OFF, as required.

AFTER LANDING (ABBREVIATED)

- 1. Flight Controls — Neutralize.
- 2. Cyclic trim indicators — Check GND indication.
- F** 3. Ground Contact lights — Check both ON.

ENGINE SHUTDOWN

- 1. Flight Controls — Neutralize.
- 2. PARKING BRAKE — Set.
- ③ HTG switches — OFF.
- 4. SLT-FIL switches — OFF and stow as required.
- ⑤ AFCS SYSTEM SEL switch — OFF.
- F** 6. RAMP — As required.
- F** 7. Wheels — Chocked.

TM 1-1520-240-CL

- F 8.** Mission equipment — Safe as required.
- O** (9.) HUD — OFF.
- F 10.** Fire guard — Posted.
- ★** (11.) APU — Start.
- (12.) APU GEN switch — ON.
- (13.) GEN 1 and 2 switch — OFF (delay 2 seconds between 1 and 2).
- (14.) PWR XFER 1 and 2 switches — ON.
- 15. Cyclic trim indicators — Check GND indication.
- (16.) ENG COND levers — GND, start 2 minute cool - down.
- F 17.** 714A DECU SHUTDOWN BIT — Check.
- (18.) FUEL CONTR switches — Set.
- F 19.** Droop stops — Engaged.
- (20.) ENG COND levers — STOP after 2 minute cool-down.
- 21. Avionics — OFF.
- FO 22.** Radar Altimeters — OFF.
- O** (23.) EAPS Fan switches — OFF.
- F 24.** MAINTENANCE PANEL — Check.
- (25.) 714A FADEC B/U PWR switch — OFF.
- 26. PWR XFER 1 and 2 switches — OFF after rotors have stopped.
- 27. APU GEN switch — OFF.
- 28. APU switch — OFF.
- 29. Light switches — OFF as required.
- 30. BATT switch — OFF.

TM 1-1520-240-CL

31. Ignition lock switch — OFF.
32. **712** EMERGENCY POWER panel — Check.

BEFORE LEAVING HELICOPTER

1. Walk around inspection — Perform.
- F** 2. Check fluid levels, bypass indicators and filter buttons, jam indicators, cabin and mission equipment secured, tiedowns, grounding cables, and covers.
3. Complete all forms and record.
4. Helicopter — Secure as required.

ENGINE

DUAL ENGINE FAILURE

1. AUTOROTATE.
2. External cargo — Jettison.
3. ALT switch — Disengage.

Single Engine Failure; Low Altitude/Low Airspeed And Cruise

Continued flight is possible:

1. Thrust control — Adjust as necessary to maintain RRPM.
2. 712 ENGINE BEEP TRIM switch — RPM INCREASE as required.
3. External cargo — Jettison (if required).
4. ALT switch — Disengage.
5. Land as soon as practicable.
6. EMER ENG SHUTDOWN (when conditions permit).

Continued flight is not possible:

Land as soon as possible

Engine Restart During Flight

- F 1. APU — Start.
2. 712 ENG COND lever (inoperative engine) — STOP.
3. 714A ENG COND lever (inoperative engine) — STOP, then GND.
4. FIRE PULL handle — In.
5. ALL FUEL PUMP switches — ON.
6. XFEED switch — As required.
7. Starting engine — Perform.
8. APU — OFF.

712 Normal Engine Beep Trim System Failure (High Side) or N2 Governor Failure

1. Thrust control — Adjust as required to maintain RRPM within limits.
2. ENG COND lever (affected engine) — Adjust to a position between FLT and GND that will control RRPM.
3. ENGINE BEEP TRIM switch NO.1 & 2 — Adjust as required.
4. Land as soon as practicable.

712 Normal Engine Beep Trim System Failure (Low Side or Static)

1. EMERG ENG TRIM switch (affected engine) — Adjust as required.
2. EMERG ENG TRIM AUTO/MANUAL switch (affected engine) — MANUAL.
3. EMERG ENG TRIM switch (affected engine) — Adjust in coordination with the ENGINE BEEP TRIM NO. 1 & 2 switch to normal operating RRPM and match torque.

714A FADEC FAILURES

714A FADEC 1 or FADEC 2 Caution

1. FADEC INC-DEC beep switch (affected engine) — Adjust as required.
2. Reduce rate of Thrust CONT lever change.

714A FADEC 1 and FADEC 2 Cautions

1. FADEC ENG 1 and ENG 2 INC-DEC beep switches — Beep to 100 percent. Match TQs.
2. Reduce rate of Thrust CONT lever change.
3. Land as soon as practicable.

714A Engine Fluctuations without FADEC 1/2 Light

Load share switch — Select PTIT.

If engine power fluctuations are not corrected.

1. Load share switch — Select TQ.
2. No. 1 engine FADEC switch — REV.

If engine power fluctuations are not corrected.

3. No. 1 engine FADEC switch — PRI.
4. No. 2 engine FADEC switch — REV.

If engine power fluctuations are not corrected.

Land as soon as practicable.

714A Reversionary System Failures

714A REV 1 and/or REV 2 (WITHOUT) ASSOCIATED FADEC Light(s) ON

Do not SEL REV on the affected engine.

714A REV 1 or REV 2 (WITH) ASSOCIATED FADEC Light ON

1. Land as soon as possible.
2. EMER ENG SHUTDOWN — As required.

714A REV 1 and REV 2 (WITH) ASSOCIATED FADEC Lights ON

1. Land as soon as possible.
2. EMER ENG SHUTDOWN — As required.

Engine Transmission Clutch Failure To Engage

1. EMER ENG SHUTDOWN — (affected engine).

When N1 reaches zero (0):

2. EMER ENGINE Shutdown — (engaged engine).

Engine Shutdown — Complete Electrical Failure

- F 1. FUEL VALVE #1 and #2 ENGINE — CLOSE.
2. Normal shutdown — Perform.

Engine Shutdown — Condition Lever Failure

1. FIRE PULL handle (affected engine) — Pull.
2. Normal shutdown — Perform.

Engine Shutdown With APU or APU Generator Inoperative

1. No. 2 Engine — Perform a normal shutdown.
2. All unnecessary electrical switches (except BATT switch) — OFF.
3. GEN 1 and 2 switches — OFF.
4. ENG COND 1 lever — GND. Wait until PTIT decreases and then begins to increase; then move the ENG COND 1 lever to STOP.
5. ENG 1 START switch — MTR until rotors stop or PTIT is below 260°C.
6. Normal shutdown — Perform.

Engine Oil — Low Quantity/High Temperature/High or Low Pressure

1. If engine power is required for flight:
Land as soon as possible.
2. If engine power is NOT required for flight:
 - a. EMER ENGINE SHUTDOWN— (affected engine).
 - b. Land as soon as practicable.

Engine Chip Detector Caution Light ON

1. If engine power is required for flight:
Land as soon as possible.
2. If engine power is not required:
 - a. EMER ENGINE SHUTDOWN — (affected engine).
 - b. Land as soon as practicable.

ROTOR, TRANSMISSION, AND DRIVE SYSTEMS

NO. 1 or NO. 2 ENG XMSN HOT Caution

1. EMER ENG SHUTDOWN.
- F 2. Affected engine transmission — Check.
3. Land as soon as possible.

Transmission Debris Screen Latches

FWD, COMB, or AFT DEBRIS SCREEN indicator:

F RESET/GND/TEST switch — RESET.

If indicator does not reset:

Land as soon as possible.

LEFT or RIGHT DEBRIS SCREEN indicator:

F RESET/GND/TEST switch — RESET.

If indicator does not reset and engine power is required:

Land as soon as possible.

If indicator does not reset and engine power is not required then:

1. EMER ENG SHUTDOWN.
2. Land as soon as practicable.

XMSN OIL PRESS Caution

AFT or AFT SHAFT (confirm aft shaft with flight engineer):

Land as soon as possible.

FWD or COMB (MIX):

1. Altitude — Descend to minimum safe attitude.
2. Airspeed — 100 KIAS or Vne whichever is slower.
3. Land as soon as practicable.

LEFT or RIGHT

Engine power is required:

Land as soon as possible.

Engine power is not required:

1. EMER ENG SHUTDOWN.
2. Land as soon as practicable.

**XMSN OIL PRESS and XMSN AUX OIL PRESS or
XMSN CHIP DET CAUTION**

Land as soon as possible.

XMSN AUX OIL PRESS Caution

MAIN XMSN (FWD, COMB (MIX), or AFT)

*Main transmission oil pressure and/or temperature are
abnormal:*

Land as soon as possible.

*Main transmission oil pressure and/or temperature are
normal:*

Land as soon as practicable.

XMSN OIL HOT Caution

FWD or COMB (MIX)

Land as soon as possible.

AFT transmission is indicated:

1. **Land as soon as possible.**
2. **Electrical load — Reduce** as much as possible.

LEFT or RIGHT

Engine power is required:

Land as soon as possible.

Engine power *is not* required:

1. **EMER ENG SHUTDOWN.**
2. Land as soon as practicable.

712 Torque Measuring System Malfunctions

1. AC and DC Torque circuit breakers — In.
2. N1s — Monitor when power changes are made, insuring power outputs are matched.
3. Fuel flow indicator — Monitor for matched fuel flows.

714A Torque Measuring System Malfunctions

N1 and PTIT indicators — Check.

N1s and PTITs not matched

1. LOAD SHARE switch — PTIT
2. PTIT indicators — Check.

PTITs not matched

Land as soon as practicable.

N1s and PTITs are matched

AC and DC Torque and Engine circuit breakers — IN.

FIRE

Engine Hot Start

ABORT START.

Residual Fire During Shutdown

1. **ABORT START.**
2. **FIRE PULL handle (affected engine) — Pull.**

Auxiliary Power Unit (APU) Fire

1. **APU switch — OFF.**
2. **ABORT START.**

Engine or Fuselage Fire — Flight

1. Land as soon as possible.
- F 2. Confirm fire.
3. EMER ENG SHUTDOWN (affected engine).

After landing:

EMER ENG SHUTDOWN.

Engine Compartment, Fuselage or Electrical Fire — Ground

1. EMER ENG SHUTDOWN.
2. APU switch — OFF (if operating).
3. BATT switch — OFF.

Electrical Fire — Flight

1. Airspeed — 100 KIAS or Vne whichever is slower.
2. GEN 1 and 2 switches — OFF.
3. Land as soon as possible.

After landing:

4. EMER ENG SHUTDOWN.
5. BATT switch — OFF.

Smoke and Fume Elimination

1. Airspeed — Above 60 KIAS.
2. Pilot's sliding window — Open.
3. Helicopter attitude — Yaw left, one half to one ball width on turn and slip indicator.
4. Upper half of main cabin door — Open.
- O 5. RAMP EMER switch — As required.
6. Cargo loading ramp — As required.
7. Copilot's sliding window — Closed.
8. NVG curtain — Open (if applicable).

FUEL SYSTEM

Aux Fuel Pump Failure

1. FUEL QUANTITY selector switch — Check.

If one or both auxiliary fuel tanks have fuel remaining:

2. AC-DC FUEL PUMP circuit breakers — Check in.
3. FWD and AFT AUX FUEL PUMP switches (affected side) — OFF.
4. AUX FUEL PUMP switch — ON (each aux tank with fuel remaining).

If AUX PRESS indicating light remains on:

5. AUX FUEL PUMP switch(es) (inoperative pumps(s)) — OFF. Monitor FUEL QUANTITY indicator for the affected tank.
6. AUX FUEL PUMP switch(es) — ON for operative pumps or OFF for inoperative pumps.

FUEL VENTING

1. **AUX FUEL PUMP switches (affected side) — OFF.**
2. Main tank (affected side) — Monitor.

When 1,000 pounds of fuel remain:

3. AUX FUEL PUMP switches — ON (monitor fuel quantity).

When tank quantity reaches 1,600 pounds:

4. AUX FUEL PUMP switches — OFF.
5. Steps 2 through 4 — Repeat until auxiliary tanks are empty.

L or R FUEL PRESS Caution

1. **XFEED switch — OPEN (above 6,000 feet PA).**
2. FUEL PUMP(S) circuit breakers — Check in.

Pump(s) are operational — Proceed with step 3.

Pump(s) are not operational — Proceed with step 4.

3. XFEED switch — CLOSED.
4. FUEL PUMP switches — OFF (inoperative pump(s)).

Fuel Low Caution

1. Fuel quantify — Check individual tanks.
2. XFEED switch — As required.
3. Land as soon as practicable.

Fuel Low and Fuel Pressure Caution

1. **XFEED — CLOSED.**
2. **Land as soon as possible.**

ELECTRICAL SYSTEM

NO. 1 or NO. 2 GEN OFF CAUTION

If no bus tie exists and the failed generator cannot be restored:

Land as soon as possible.

If only the No. 1 or No. 2 GEN OFF caution is illuminated, a bus tie exists:

1. GEN switch — OFF RESET, then ON.

If the caution remains on:

2. GEN switch — OFF.
3. Land as soon as practicable.

NO. 1 and NO. 2 GEN OFF Cautions

1. **Land as soon as possible.**
2. **712 EMER ENG Trim — Adjust.**

If unable to land proceed as follows:

1. Airspeed — below 100 KIAS.
2. Altitude — below 6,000 feet PA
3. AFCS — OFF.

4. PDP's — Check circuit breakers and place gang bar down.
5. Each GEN switch — OFF RESET, then ON.

Electrical power is restored (from either generator):

Land as soon as possible.

Electrical power is not restored:

1. APU — Start.
2. APU GEN — ON.
3. **Land as soon as possible.**

NO. 1 or NO. 2 RECT OFF Caution

DC bus tie has not occurred:

Land as soon as possible.

DC bus tie has occurred (only the RECT OFF caution will be on):

1. PDP's — Check.
2. Land as soon as practicable.

NO. 1 and NO. 2 RECT OFF Cautions

If both transformer rectifiers fail, perform the following:

1. **Land as soon as possible.**
2. **712 EMER ENG TRIM — Adjust.**

If unable to land, proceed as follows:

1. Airspeed — below 100 KIAS.
2. Altitude — below 6000 feet PA..
3. AFCS — OFF.
4. PDP's — Check circuit breakers in.
5. DC Crosstie circuit breakers on both No. 1 and No. 2 PDPs — Pull out.
6. DC Equipment — OFF or pull out circuit breakers.
7. **Land as soon as possible.**

BATT SYS MAL Caution

1. BATT CHGR circuit breaker — Out, then in.

If the BATT SYS MAL caution remains on:

2. BATT switch — OFF.

HYDRAULIC

NO. 1 or NO. 2 HYD FLT CONTR Caution

Fluid loss is evident

Land as soon as possible.

Fluid loss is not evident

1. **PWR XFER 1 or 2 switch (affected system) — ON.**

F 2. **MAINTENANCE PANEL — Monitor.**

3. **Land as soon as possible.**

High fluid temperature is evident.

Land as soon as possible.

NO. 1 and NO. 2 HYD FLT CONTR Caution

1. **PWR XFER 1 and 2 switches — ON.**
2. **Land as soon as possible.**

UTIL HYD SYS Caution

APU — Start.

If pressure is restored:

1. Land as soon as practicable.
- F 2. MAINTENANCE PANEL — Monitor.

If pressure is not restored:

1. APU — Off.
2. **Land as soon as possible.**

LANDING AND DITCHING

Emergency Descent

High Speed Straight Ahead Descent:

1. Thrust control — Lower (approximate 104% RRPM).
2. Airspeed — Adjust (approximate 130-150).
3. Recovery — Initiate at or above 600 feet AGL (descent 70-80 KIAS).

Out-of-Trim Descent:

1. Thrust control — Lower (approximate 104% RRPM).
2. Airspeed — Adjust (approximate 100 KIAS).
3. Trim — Adjust (1 ball width R).
4. Recovery — Initiate at or above 600 feet AGL (trim 70 KIAS).

Low Speed Maneuvering Descent:

1. Thrust control — Lower (approximate 102% RRPM).
2. Airspeed — Adjust (70-90).
3. Bank angle — Adjust (up to 60°).
4. Recovery — Initiate at or above 600 feet AGL (wings level).

DITCHING

Power Off

AUTOROTATE.

Power On

1. Land away from personnel in the water.
2. EMER ENG SHUTDOWN.

LANDING IN TREES

Power off:

AUTOROTATE.

Power on:

1. **Approach to a hover — 5 to 10 feet.**
2. **EMER ENG SHUTDOWN.**
3. **AUTOROTATE.**

FLIGHT CONTROLS

Longitudinal Cyclic Trim (LCT) System Failure

If in AUTO mode:

1. **Airspeed — Adjust.**
2. CYCLIC TRIM switch — MANUAL.
3. FWD and AFT CYCLIC TRIM switches — Adjust for airspeed.

If LCT operation is not indicated:

FWD and AFT CYCLIC TRIM switches — RET for 30 seconds, before landing.

If in MANUAL mode:

1. **Airspeed — Adjust.**
2. CYCLIC TRIM switch — AUTO.

If normal LCT operation is not indicated:

1. CYCLIC TRIM switch — MANUAL.
2. FWD and AFT CYCLIC Trim switches — RET both LCTS for 30 seconds, before landing.

Single AFCS Failure — BOTH Selected

1. **Airspeed — Reduce** to 100 KIAS or Vne, whichever is slower.
2. **Altitude — Adjust** as required.
3. AFCS SYSTEM SEL switch — Isolate defective system. Turn No. 1 ON, if not isolated, turn No. 2 ON.

If system *is not* isolated:

AFCS SYS SEL switch — OFF.

Dual AFCS Failure

AFCS SYSTEM SEL switch — OFF.

If IMC:

Land as soon as practicable.

Vertical Gyro (VGI) Malfunction

1. **Airspeed — Reduce to 100 KIAS or Vne, whichever is slower.**
2. Affected VGI switch — EMER.
3. AFCS — Select remaining system.

Differential Airspeed Hold (DASH) Failure

Avoid nose high attitudes.

Cockpit-Control Driver Actuator (CCDA) Failure

1. THRUST CONT Lever — Slip as required.
2. RAD ALT/BARO ALT switch — DISENGAGED.

MISSION EQUIPMENT

Armament Subsystems — M24 and M41

Misfire:

- F 1. **Weapon — Point at safe area.**
- F 2. **Bolt — Retract, remove cartridge.**
- F 3. If cartridge does not eject — Perform remedial action.

Runaway Gun:

- F **Break the ammunition feed belt.**

CARGO

Jettisoning External Cargo

Primary Method:

CARGO HOOK EMERG switch — REL ALL.

Alternate Method.

F Forward, center, and aft hook release lever — Pull aft.

HOIST

1. Personnel — Clear.
2. CABLE CUTTER switch — ON.

ERFS II and FARE

Failure of Fuel Quantity Gauge

F Remove filler cap from filler opening and look into tank. Using an explosion proof flashlight or other sealed beam light source locate fuel tabs which are attached to inside of column module at calibrated heights, in increments of 1/4, 1/2, and 3/4. Any tab covered with fuel will normally not be visible.

No or Slow Fuel Transfer to the Main Tanks

- F 1. Manually operated fuel/defuel valve — Check CLOSED.
- F 2. UNISEX COUPLINGS — Check OPEN.
- F 3. Breakaway valves — Check OPEN and for fracture.
- F 4. Pumps — Check for operation.
- F 5. Tank circuit breakers on FUEL CONTROL PANEL — Check reset IN.
- F 6. Ensure vent lines connected.

IN FLIGHT Emergency ERFS II Fuel Transfer to Main Tanks

Using the FARE Fuel pump.

- F 1. FARE pump module to rear most ERFS II tank — Install.
- F 2. STA 380 fuel transfer hose to rear most ERFS II tank fuel manifold hose — Disconnect.



TM 1-1520-240-CL

- F 3. Rear most ERFS II tank fuel manifold coupling to FARE pump inlet (top) coupling — Connect.
- F 4. FARE pump module outlet lower coupling to STA 380 fuel transfer hose — Connect.
- F 5. “T” coupling on ERFS II tanks not being transferred — CLOSE.
- F 6. FARE valve control handle — OFF LOAD position.
- F 7. FARE pump — ON.
- F 8. ERFS II tank manually operated fuel/defuel valve — OPEN.
- F 9. Once ERFS II tank empties, tank fuel manifold “T” coupling — CLOSE.
- F 10. Next ERFS II tank fuel manifold “T” coupling — OPEN.
- F 11. Next/remaining ERFS II tank manually operated fuel/defuel valve — OPEN.
- F 12. Once ERFS II tank empties tank fuel manifold “T” coupling — Close.
- F 13. FARE pump— OFF.

FARE Pump Failure During Ground FARE Refueling Operation

- F 1. Filters — Remove.
- F 2. Overwing nozzle — Install and use.
- F 3. Manually operated fuel/defuel valves — OPEN.
- F 4. ERFS II tank pumps — ON.

EAPS 1 FAIL and/or EAPS 2 FAIL Caution Light ON

- 1. EAPS DOORS switch (affected engine) — OPEN.
- 2. EAPS FAIL caution capsule — Check OUT.
- F 3. EAPS BYPASS DOORS OPEN light — Verify Light is ON.

E-17/(E-18 blank)



DETAILED PROCEDURES

ERFS II

For each installed ERFS II Tank Assembly.

1. Tank restraint assembly — Check location and security.
2. Cavity overboard drain — Check connection and security of drain in use. Check drain not in use is capped.
3. Grounding cable — Check connection security.
4. Vent hose assembly — Check connection security. Ensure dust cover is secure on retention strap and connection to dust cap stowage connector.
- 5. Fuel transfer hose assembly — Check connection security; all Unisex valves OPEN.
- 6. Single point pressure refueling hose assembly — Check connection security; Unisex valve at ERFS II Tank CLOSED.
7. Electrical Harness — Check connection security of J1.
8. Fuel quantity sensing wiring harness — Check connection security of J2.
9. Fuel/defuel vent valve — Check in the CLOSED position.
10. ERFS II tank sump fuel sample — Check before first flight of the day.
11. Filler cap — Check in place, closed, and locked.
12. ERFS II Fuel Control Panel — Check or set as follows:
 - a. Electrical harness - Helicopter receptacles to fuel control panel — Check connection security of J5.
 - b. Electrical harness - Fuel control panel to tank assembly — Check connection security of J1, J2, and J3.

TM 1-1520-240-CL

- c. Wiring harness - Fuel quantity sensing — Check connection security of J4.
- d. PUMP AC circuit breakers, six (6) each — Check in reset position on TANK 1, TANK 2, and TANK 3 (if installed).
- e. PANEL POWER circuit breaker — Check in reset position.
- f. PANEL LIGHTING circuit breaker — Check in reset position.
- g. PUMP switches — OFF on TANK 1, TANK 2, and TANK 3.
- h. PRESS LOW lights, three (3) each — Press to test (Aircraft power must be on to illuminate).
- i. REFUEL VALVE — Check CLOSED.
- j. Panel illumination switch/rheostat — OFF.
- k. FUEL QUANTITY switch — Set 1, 2, 3 and TOTAL to check quantity in each tank (aircraft power must be on to illuminate).

HYDRAULIC COMPARTMENTS CHECKS

AFT COMPARTMENT

- 1. Condition and security of lines and coolers.
- 2. No. 2 flight control system accumulator for proper indication (see chart this section).
- 3. Utility reservoir pressurization accumulator for **2500** to **3500** psi charge.

FORWARD COMPARTMENT

- 1. Condition and security of lines and coolers.
- 2. No. 1 flight control system accumulator for proper indication (see chart this section).

OVERHEAD SWITCHES AND CONTROL PANELS

- O* 1. EAPS ENG 1 and ENG 2 FAN switches — OFF
DOORS — Close.
- * 2. EXT LTG switches — As required.
- * 3. CPLT LTG switches — As required.
 - 4. COMPASS switch — As required.
 - 5. TROOP WARN switches — OFF.
 - 6. HTG switches — As required.
 - 7. W/S WIPER switch — OFF.
 - 8. ELECT switches — OFF.
- * 9. LTG switches — As required.
- * 10. FUEL CONTR switches — Set as follows:
 - a. XFEED switch — CLOSED.
 - b. REFUEL STA switch — OFF.
 - c. All FUEL PUMP switches — OFF.
- 11. 712 START switches — OFF.
- 12. ENG COND levers — STOP.
- * 13. 714A FADEC switches — Check or set as follows:
 - a. NR% switch — 100%.
 - b. 1 and 2 PRI/REV switches — PRI.
 - c. B/U PWR switch — OFF.
 - d. LOAD SHARE switch — TRQ.
- 14. INTR LTG switches — As required.
- 15. PLT LTG — As required.
- 16. ANTI-ICE switches — OFF.
- 17. HOIST switches — OFF.
- 18. CARGO HOOK switches — Set as follows:
 - a. MSTR switch — OFF.
 - b. HOOK SEL switch — As required.

TM 1-1520-240-CL

- c. EMERG REL ALL switch — OFF. Cover down.
- 19. HYD switches — Set as follows:
 - a. PWR XFER switches — OFF.
 - b. FLT CONTR switch — BOTH.
 - c. BRK STEER switch — ON. Cover down
 - d. RAMP PWR switch — ON.
 - O** e. RAMP EMER switch — HOLD. Cover down.

APU START

- * 1. BATT switch — ON.
- F*** 2. Fire guard — Posted.
- * 3. APU — Start as follows:
 - a. APU switch — Run for **3** to **5** seconds.
 - b. APU switch — Start for **2** seconds, then RUN.
 - c. APU ON indicating light — Check on.
- * 4. UTIL HYD SYS caution — Check out within **30** seconds after APU ON light.

CARGO HOOK OPERATIONAL CHECK

- 1. CARGO HOOK MSTR switch — ARM.
- 2. CARGO HOOK SEL switch — FWD.
- 3. CARGO HOOK RELEASE switch (pilot's cyclic) — Press.
- 4. CARGO HOOK SEL switch — MID.
- 5. CARGO HOOK RELEASE switch (copilot's cyclic) — Press.
- 6. CARGO HOOK SEL switch — AFT.
- F** 7. CARGO HOOK switch on HOIST OPERATORS PANEL — ARM.
- F** 8. CARGO HOOK RELEASE switch (WINCH/HOIST CONTROL GRIP) — PRESS.

TM 1-1520-240-CL

9. CARGO HOOK MSTR switch — RESET and release to OFF, then set to ARM.
 10. CARGO HOOK SEL switch — TANDEM.
 11. CARGO HOOK RELEASE switch (pilot's cyclic) — Press.
 12. CARGO HOOK MSTR switch — RESET and release to OFF, then set to ARM.
 13. CARGO HOOK SEL switch — ALL.
 14. CARGO HOOK RELEASE switch (copilot's cyclic) — Press.
 15. CARGO HOOK MSTR switch — RESET and release to OFF.
- F 16. CARGO HOOK RELEASE switches — Press.

FLIGHT CONTROL TRAVEL AND HYDRAULICS (FOR THUR FLIGHTS PERFORM STEPS 2 THUR 5 IN BOTH)

1. FLT CONTR Hydraulic switch — 1 ON.
2. Check cyclic for freedom of movement in all quadrants. Check for minimum of 7 inches forward and 4 inches aft travel.
3. Check thrust through full travel for freedom of movement and magnetic brake for proper operation.
4. Check pedals through full travel for freedom of movement.
5. Position the cyclic and pedals at neutral, thrust at ground detent.
6. FLT CONTR Hydraulic switch — 2 ON, repeat steps 2 thru 5.
7. FLT CONTR Hydraulic switch — BOTH.

714A DECU PRESTART BIT

1. B/U PWR switch — On.
2. Wait until ENG FAIL, FADEC, and REV Lights go out.

TM 1-1520-240-CL

3. ENG COND levers — GND.
- F 4. DECUs — display 88 (if other than 88, consult DECU BIT Fault CodeList/Matrix).
5. ENG COND levers — STOP.

ENGINE START (EITHER ENGINE)

712 First engine — Start as follows:

1. L MAIN FUEL Pumps — ON. Check L FUEL PRESS Caution Light OUT.
2. XFEED switch — OPEN. Check R FUEL PRESS Caution Light — OUT.
3. ENG COND lever — STOP.
4. ENG START switch — MTR.
5. Motor engine to a minimum of **15%** N1. Set ENG COND lever — GND; ENG START switch to START immediately.
6. Release START switch to MTR before PTIT reaches **200°C**. When N1 is **50%**, set START switch to OFF. Check STARTER ON light out.
7. Engine instruments — Check when stabilized at ground idle (N1 at **60° minimum**). Check engine oil pressure for **20 psi** minimum. The engine should accelerate to ground idle speed within **45** seconds.

714A First engine — Start as follows:

Primary

1. L MAIN FUEL Pumps — ON. Check L FUEL PRESS Caution Light OUT.
2. XFEED switch — OPEN. Check R FUEL PRESS Caution Light — OUT.
3. ENG COND lever — GND.
4. ENG START switch — Start and Hold until N1 accelerates to 10% then release.
5. Engine instruments — Check when stabilized at ground idle (N1 at **50% minimum**). Check engine oil pressure for **5 psi** minimum. The engine should accelerate to ground idle speed within **45** seconds.

TM 1-1520-240-CL

Reversionary (if engine does not start in PRI and all other indications are normal):

1. DECU PRE-START BIT — Perform.
2. PRI/REV switch — REV
3. ENG COND Lever — GND.
4. ENG START switch — Start and hold until N1 accelerates to 10 % then release.
5. Engine instruments — Check when stabilized at ground idle (N1 50 to 60%). Check engine oil pressure for 5 psi minimum. The engine should accelerate to ground idle speed within 45 seconds.
6. DECU BIT — Check 88s (if other than 88, consult DECU Fault Code List/Matrix).
7. FADEC PRI/REV switch — PRI.

Second engine — Start by using the same method as first engine.

714A DECU START BIT

1. ENG COND levers — Retard 5 degrees.
- F 2. DECU display — Check display read 88 (if other than 88, consult DECU Fault Code List/Matrix)..
3. ENG COND levers — FLT.

FUEL PUMP AND XFEED CHECK

FUEL PUMP and XFEED check operation as follows:

1. All FUEL PUMP switches — OFF. Check L and R FUEL PRESS caution capsules should come on.
2. L AFT MAIN FUEL PUMP switch — ON. Check L and R FUEL PRESS caution capsules should go out. Then switch OFF.
3. Remaining MAIN FUEL PUMP switches — Check as in step 2 above.
4. L AFT AUX FUEL PUMP switch — ON. Check L AUX PRESS light on overhead panel come on, then goes out. Set pump switch to OFF.

TM 1-1520-240-CL

5. Remaining three AUX FUEL PUMP's — Check as in step 4, except check R AUX PRESS light on, then off, for R AUX FUEL PUMP switches.

714A FADEC Reversionary system — Check First flight of the day.

1. FADEC 1 and 2 PRI-REV switches — PRI.
2. NR% switch — 100%.
3. FADEC 1— Check as follows:
 - a. FADEC 1 PRI-REV switch — REV.
 - b. FADEC 1 INC - DEC switch — DEC. Check for decrease in No. 1 engine N1 and torque, and corresponding increase in No. 2 engine N1 and torque.
 - c. FADEC 1 INC - DEC switch — INC. Check for increase in No. 1 engine N1 and torque, and corresponding decrease in No. 2 engine N1 and torque.
 - d. FADEC 1 PRI-REV switch — PRI.
4. Repeat check for FADEC 2.

Transponder Check and Set.

1. Move the MASTER switch from OFF to STBY. If the aircraft is so equipped, observe that the STBY light on the aircraft advisory panel comes on. Also, note that the NO GO light is on.
2. Allow 2 minutes for warmup.
3. Select the codes assigned for use in modes 1 and 3/A by depressing and releasing the pushbutton for each switch until the desired number shows.
4. Operate the PRESS-TO-TEST feature of the lamp indicators.
5. Place the ANT switch BOT.
6. Move the MASTER switch from STBY to NORM.
7. Hold the M-11 switch to TEST, observe that the TEST/GO indicator lights.

TM 1-1520-240-CL

8. Restore the M-1 switch to ON.
9. Repeat (7) and (8) above for the M-2, M-3/A and M-C mode switches.
10. Place the ANT switch TOP.
11. Repeat (7), (8), and (9) above.
12. Place the ANT switch DIV.
13. Repeat (7), (8), and (9) above.

NOTE

If KIT1C is not installed or keyed the following steps are not required.

14. Set the MODE 4 rotary switch to A. If the external computer is used, set a code in it.
15. Set the MODE 4 AUDIO/LIGHT/OUT switch to OUT.
16. Hold the MODE 4 TEST/ON/OUT switch to TEST.
17. If the computer is used, observe that the TEST GO indicator lights. If the computer is not connected, observe that the TEST/MON/NO GO indicator lights and the KIT STATUS indicator lights.
18. Observe that the MODE 4 REPLY light and CAUTION light (on a separate "panel") do not light.
19. Restore the MODE 4 TEST/ON/OUT switch to ON for computer use, or to OUT if no computer is used.

TM 1-1520-240-CL

Engine Fire Extinguisher Bottles Pressures

AMBIENT TEMPERATURE (C)	MINIMUM INDICATION (PSI)
-54°	271
-51°	275
-40°	292
-29°	320
-18°	355
-7°	396
4°	449
15°	518
27°	593
38°	691
52°	785

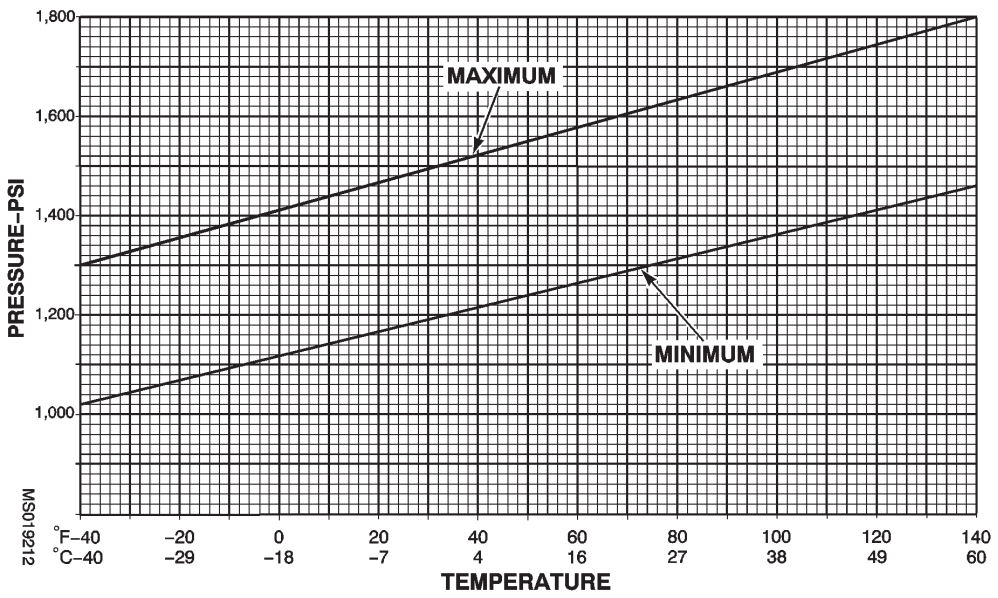

Figure P-1. Flight Control, Utility System, Power Steering, and Signal Accumulators Precharge Limits

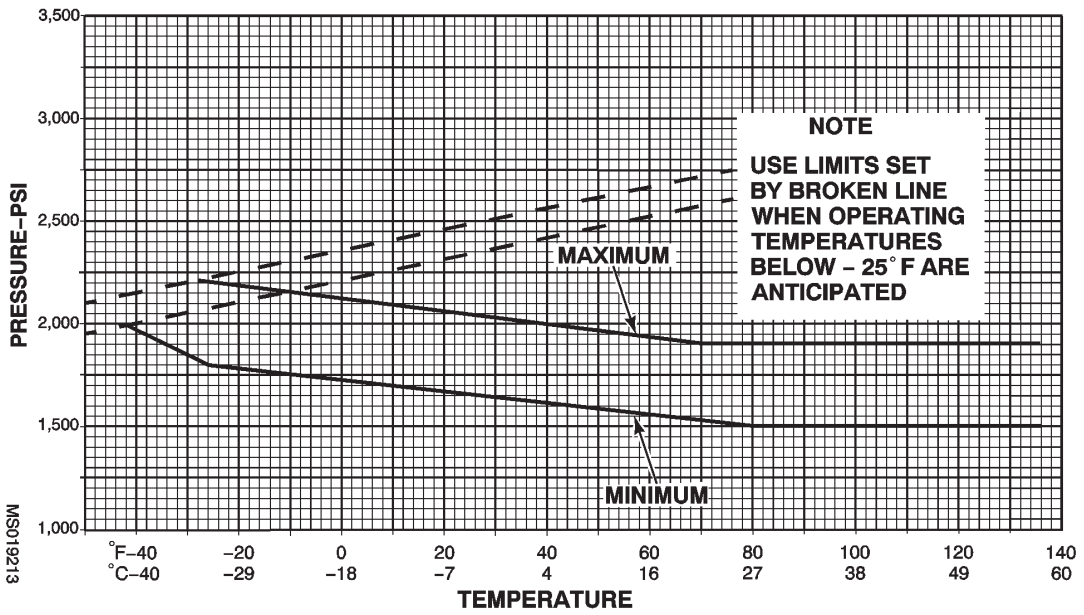

Figure P-2. APU Start Accumulator Precharge Limits
P-12

WANTED: MAXIMUM WIND GUST FOR ROTOR SHUTDOWN

KNOWN: STEADY STATE WINDS (18 KNOTS) AND DIRECTION RELATIVE TO AIRCRAFT NOSE (105° RELATIVE)

METHOD: ENTER STEADY STATE WIND HERE - - - - - MOVE UP TO EDGE OF LINE MOVE LEFT TO READ MAXIMUM ALLOWABLE GUST ABOVE STEADY STATE 8KTS

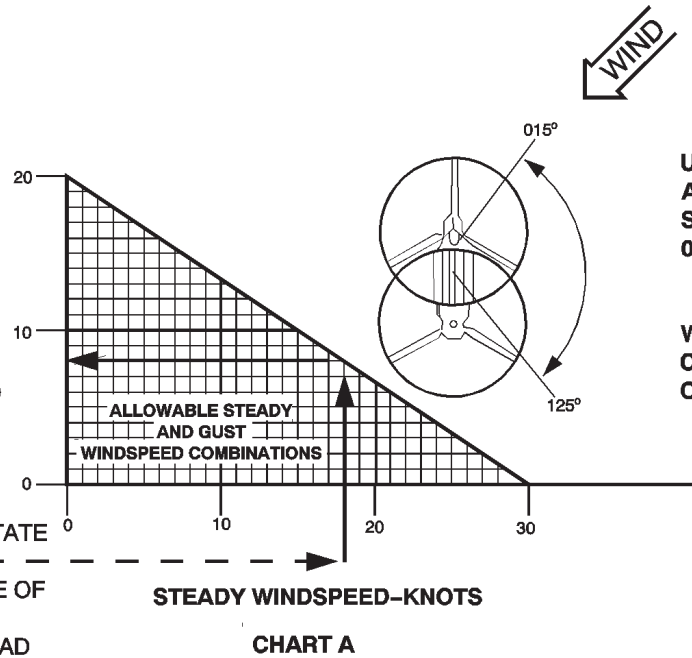

CHART A
 USE THIS CHART TO DETERMINE MAXIMUM ALLOWABLE WINDS FOR ROTOR START AND SHUT DOWN WHEN KNOWN WINDS ARE FROM 015° TO 125° RELATIVE TO THE NOSE OF AIRCRAFT

OR
 WIND IS FROM ANY DIRECTION AND AIRCRAFT IS CLOSER THAN 300 FEET FROM ANY VERTICAL OBSTRUCTIONS OR ANY SUDDEN TERRAIN CHANGES

NOTE
 IF WINDS ARE IN EXCESS OF CHART "A" LIMITS REPOSITION THE AIRCRAFT AND USE CHART "B"

Figure FO-1. Steady Windspeed - Knots (Chart A)

WANTED: EXAMPLE
 MAXIMUM WIND
 GUST FOR ROTOR
 SHUTDOWN

KNOWN: STEADY STATE
 WINDS (23 KNOTS)
 AND DIRECTION
 RELATIVE TO
 AIRCRAFT NOSE
 (245° RELATIVE)

METHOD: ENTER STEADY STATE
 WIND HERE - - - - ->
 MOVE UP TO EDGE OF
 LINE
 MOVE LEFT TO READ
 MAXIMUM ALLOWABLE
 GUST ABOVE STEADY
 STATE
 +13KTS

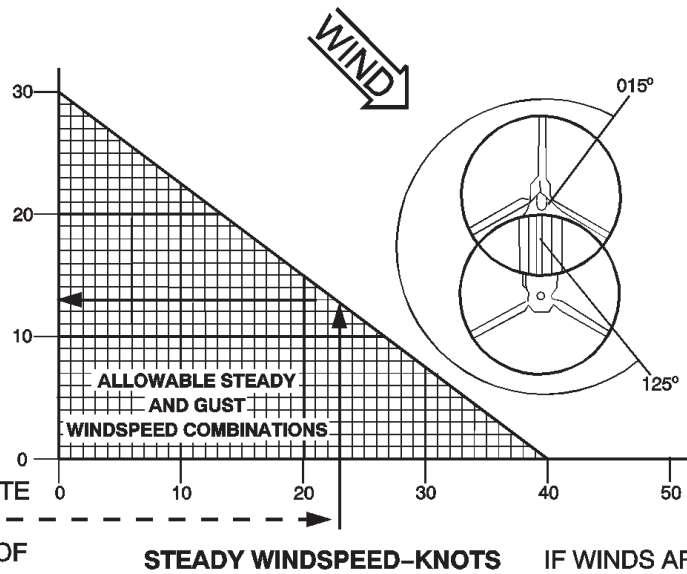

STEADY WINDSPEED-KNOTS

CHART B

CHART B
 USE THIS CHART TO DETERMINE MAXIMUM
 ALLOWABLE WINDS FOR ROTOR START AND
 SHUT DOWN WHEN KNOWN WINDS AND GUST
 EXCEED THE MAXIMUM ALLOWABLE IN
 CHART A

OR
 KNOWN WINDS ARE FROM 125° TO 015°
 RELATIVE TO THE NOSE OF AIRCRAFT
 AND
 AIRCRAFT IS ON CLEAR LEVEL GROUND AT
 LEAST 300 FEET FROM VERTICAL
 OBSTRUCTIONS OR ANY SUDDEN TERRAIN
 CHANGES

NOTE

IF WINDS ARE IN EXCESS OF CHART "A" AND CHART "B" LIMITS
 THE AIRCRAFT SHOULD BE SHUT DOWN IN AN AREA WHICH IS
 CLEAR, AS LEVEL AS POSSIBLE, AND AT LEAST 300 FEET AWAY
 FROM ANY VERTICAL OBSTRUCTIONS OR ABRUPT CHANGES IN
 TERRAIN.

ORIENT THE AIRCRAFT SUCH THAT THE WIND WOULD BE COMING
 IN AT THE LEFT SIDE.

Figure FO-2. Steady Windspeed - Knots (Chart B)

TM 1-1520-240-CL

By Order of the Secretary of the Army:

Official:

ERIC K. SHINSEKI
General, United States Army
Chief of Staff

JOEL B. HUDSON
Administrative Assistant to the
Secretary of the Army
0230911

The Metric System and Equivalents

Linear Measure

1 centimeter = 10 millimeters = .39 inch
1 decimeter = 10 centimeters = 3.94 inches
1 meter = 10 decimeters = 39.37 inches
1 dekameter = 10 meters = 32.8 feet
1 hectometer = 10 dekameters = 328.08 feet
1 kilometer = 10 hectometers = 3,280.8 feet

Weights

1 centigram = 10 milligrams = .15 grain
1 decigram = 10 centigrams = 1.54 grains
1 gram = 10 decigrams = .035 ounce
1 dekagram = 10 grams = .35 ounce
1 hectogram = 10 dekagrams = 3.52 ounces
1 kilogram = 10 hectograms = 2.2 pounds
1 quintal = 100 kilograms = 220.46 pounds
1 metric ton = 10 quintals = 1.1 short tons

Liquid Measure

1 centiliter = 10 milliliters = .34 fl. ounce
1 deciliter = 10 centiliters = 3.38 fl. ounces
1 liter = 10 deciliters = 33.81 fl. ounces
1 dekaliter = 10 liters = 2.64 gallons
1 hectoliter = 10 dekaliters = 26.42 gallons
1 kiloliter = 10 hectoliters = 264.18 gallons

