

Documentation

BK9055 and BK9105

Bus Coupler for Ethernet/IP

Version: 2.1.0
Date: 2020-04-20

BECKHOFF

Table of contents

1 Foreword	5
1.1 Notes on the documentation.....	5
1.2 Safety instructions	6
1.3 Documentation issue status	7
2 Product overview	8
2.1 BK9055 - Introduction	8
2.2 BK9105 - Introduction	9
2.3 Technical data	10
2.4 The Beckhoff Bus Terminal system	10
2.5 Ethernet	12
3 Mounting and wiring	14
3.1 Dimensions	14
3.2 Installation on mounting rails	15
3.3 Power supply, potential groups	16
3.4 ATEX - Special conditions (standard temperature range)	18
3.5 ATEX - Special conditions (extended temperature range)	19
3.6 ATEX Documentation	20
4 Parametrization and commissioning	21
4.1 Start-up behaviour of the Bus Coupler	21
4.2 Parameterization of the Bus Coupler using DIP Switches*	21
4.3 Network classes	22
4.4 IP address	23
4.4.1 Configuration with KS2000	23
4.4.2 Address Configuration via ARP	24
4.4.3 Address configuration via BootP server.....	25
4.4.4 Setting the address using a DHCP server	29
4.4.5 Subnet mask.....	29
4.4.6 Testing the IP address.....	30
4.4.7 Reading the MAC-ID.....	30
4.5 Configuration	31
4.5.1 Mapping	31
4.5.2 EthernetIP Tag Wizard	33
4.5.3 Export to Rockwell	44
5 Error handling and diagnosis	50
5.1 Diagnostic LEDs	50
6 Appendix	54
6.1 First Steps.....	54
6.2 First Steps - Example	58
6.3 General operating conditions.....	64
6.4 Test Standards for Device Testing	65
6.5 Bibliography	66
6.6 List of Abbreviations	66
6.7 Support and Service USA.....	67

6.8 Support and Service 68

1 Foreword

1.1 Notes on the documentation

Intended audience

This description is only intended for the use of trained specialists in control and automation engineering who are familiar with the applicable national standards.

It is essential that the documentation and the following notes and explanations are followed when installing and commissioning these components.

It is the duty of the technical personnel to use the documentation published at the respective time of each installation and commissioning.

The responsible staff must ensure that the application or use of the products described satisfy all the requirements for safety, including all the relevant laws, regulations, guidelines and standards.

Disclaimer

The documentation has been prepared with care. The products described are, however, constantly under development.

We reserve the right to revise and change the documentation at any time and without prior announcement.

No claims for the modification of products that have already been supplied may be made on the basis of the data, diagrams and descriptions in this documentation.

Trademarks

Beckhoff®, TwinCAT®, EtherCAT®, EtherCAT G®, EtherCAT G10®, EtherCAT P®, Safety over EtherCAT®, TwinSAFE®, XFC®, XTS® and XPlanar® are registered trademarks of and licensed by Beckhoff Automation GmbH. Other designations used in this publication may be trademarks whose use by third parties for their own purposes could violate the rights of the owners.

Patent Pending

The EtherCAT Technology is covered, including but not limited to the following patent applications and patents: EP1590927, EP1789857, EP1456722, EP2137893, DE102015105702 with corresponding applications or registrations in various other countries.

The logo for EtherCAT, featuring the word "EtherCAT" in a bold, black, sans-serif font. A red arrow points from the top of the "A" towards the right, ending above the "T". A registered trademark symbol (®) is located to the right of the "T".

EtherCAT® is registered trademark and patented technology, licensed by Beckhoff Automation GmbH, Germany.

Copyright

© Beckhoff Automation GmbH & Co. KG, Germany.

The reproduction, distribution and utilization of this document as well as the communication of its contents to others without express authorization are prohibited.

Offenders will be held liable for the payment of damages. All rights reserved in the event of the grant of a patent, utility model or design.

1.2 Safety instructions

Safety regulations

Please note the following safety instructions and explanations!
Product-specific safety instructions can be found on following pages or in the areas mounting, wiring, commissioning etc.

Exclusion of liability

All the components are supplied in particular hardware and software configurations appropriate for the application. Modifications to hardware or software configurations other than those described in the documentation are not permitted, and nullify the liability of Beckhoff Automation GmbH & Co. KG.

Personnel qualification

This description is only intended for trained specialists in control, automation and drive engineering who are familiar with the applicable national standards.

Description of instructions

In this documentation the following instructions are used.
These instructions must be read carefully and followed without fail!

DANGER

Serious risk of injury!

Failure to follow this safety instruction directly endangers the life and health of persons.

WARNING

Risk of injury!

Failure to follow this safety instruction endangers the life and health of persons.

CAUTION

Personal injuries!

Failure to follow this safety instruction can lead to injuries to persons.

NOTE

Damage to environment/equipment or data loss

Failure to follow this instruction can lead to environmental damage, equipment damage or data loss.



Tip or pointer

This symbol indicates information that contributes to better understanding.

1.3 Documentation issue status

Version	Modifications
2.1.0	<ul style="list-style-type: none"> • Update chapter “Addressing via Beckhoff BootP server” • Update structure
2.0.0	<ul style="list-style-type: none"> • Migration • Update Technical data • ATEX notes added • Update chapter <i>Addressing via Beckhoff BootP Server</i> • Update chapter <i>Error handling and diagnosis</i> • Update structure
1.3.0	<ul style="list-style-type: none"> • BK9055 added
1.2.3	<ul style="list-style-type: none"> • <u>New: EthernetIP Tag Wizard [▶ 44]</u>
1.2.2	<ul style="list-style-type: none"> • <u>New: Update from the mapping calculator and export to Rockwell software [▶ 44]</u>
1.2.1	<ul style="list-style-type: none"> • Note about data types added to chapters <u>first steps [▶ 54]</u> and <u>mapping calculator [▶ 33]</u>
1.2.0	<ul style="list-style-type: none"> • configuration chapter updated • mapping calculator added
1.1.0	<ul style="list-style-type: none"> • internal version
1.0.0	<ul style="list-style-type: none"> • HTML documentation; valid as from firmware B3

Firmware notes

BK9105

Determine which firmware was fitted when the Bus Coupler left the factory by checking the adhesive label underneath the bus coupler (see the fifth and sixth figures of the production number).

Example:

3200B2020000

The firmware in this example is B2.

In order to update your firmware, you require the KS2000 configuration software and the serial cable included with that software. You will find the firmware under www.beckhoff.com.

Firmware	Description
B5	<u>DIP-Switch Settings [▶ 21]</u>
B3	<u>New: K-Bus Counter [▶ 31]</u>
B2	First release

2 Product overview

2.1 BK9055 - Introduction

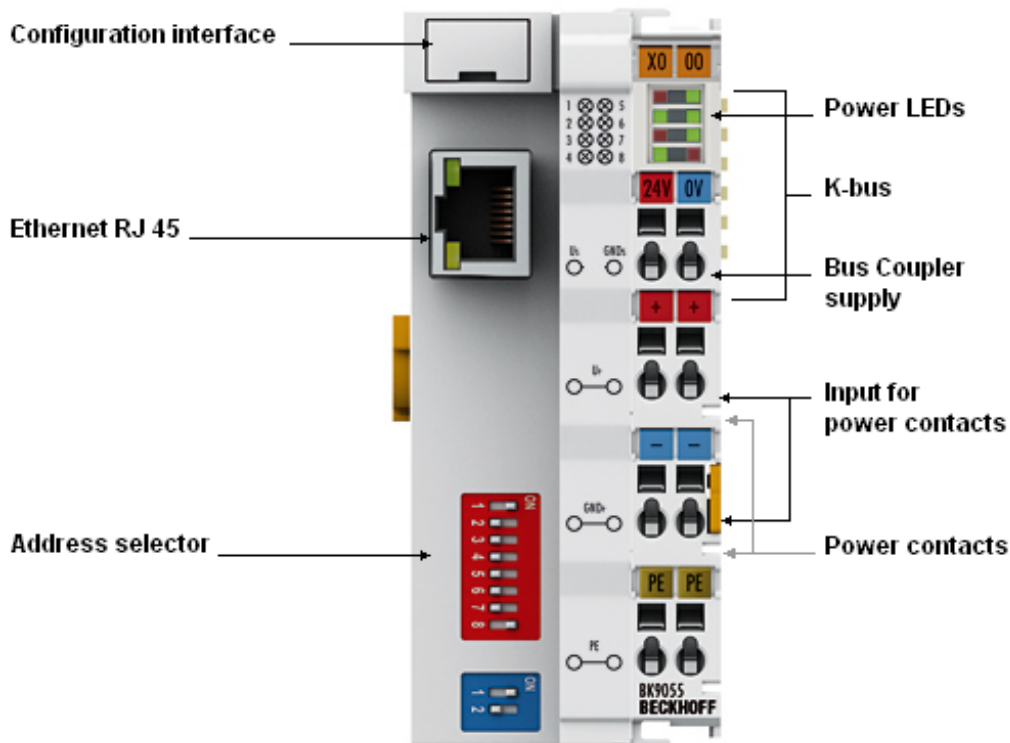

Fig. 1: BK9055

The Compact BK9055 Bus Coupler connects EtherNet/IP with the modular, extendable electronic terminal blocks. One unit consists of one Bus Coupler, any number from 1 to 64 terminals (255 with K-bus extension) and one end terminal.

The Bus Coupler recognizes the terminals to which it is connected, and performs the assignment of the inputs and outputs to the words of the process image automatically. The BK9055 Bus Coupler supports 10 Mbit/s and 100 Mbit/s Ethernet. Connection is through normal RJ 45 connectors. The IP address is set on the DIP switch (offset to a freely selectable start address). In networks with DHCP (a service for the allocation of the logical IP address to the physical node address [MAC-ID]) the Bus Coupler obtains its IP address from the DHCP server.

Ethernet/IP is the Industrial Ethernet standard of ODVA (Open DeviceNet Vendor Association). Ethernet/IP is based on Ethernet TCP/IP and UDP/IP – IP stands for Industrial Protocol. Essentially, the CIP (Common Industrial Protocol) used in ControlNet and DeviceNet was ported to Ethernet TCP/IP and UDP/IP.

Complex signal processing for analog I/Os, position measurement ...

The BK9000 and BK9050 Bus Couplers support the operation of all Bus Terminal types.

The analog and multi-functional Bus Terminals can be adapted to each specific application using the KS2000 configuration set. Depending on the type, the analog Bus Terminals' registers contain temperature ranges, gain values and linearization characteristics. With the KS2000, the required parameters can be set on a PC. The Bus Terminals store settings permanently and in a fail-safe manner.

Optionally, the Bus Terminals can also be controlled by the control system. Via function blocks (FBs), the programmable logic controller (PLC) or the Industrial PC (IPC) handles configuration of the complete periphery during the start-up phase. If required, the controller can upload the decentrally created configuration data in order to centrally manage and store this data. Therefore, new adjustments are not necessary in the event of replacement of a Bus Terminal. The controller carries out the desired setting automatically after switching on.

2.2 BK9105 - Introduction

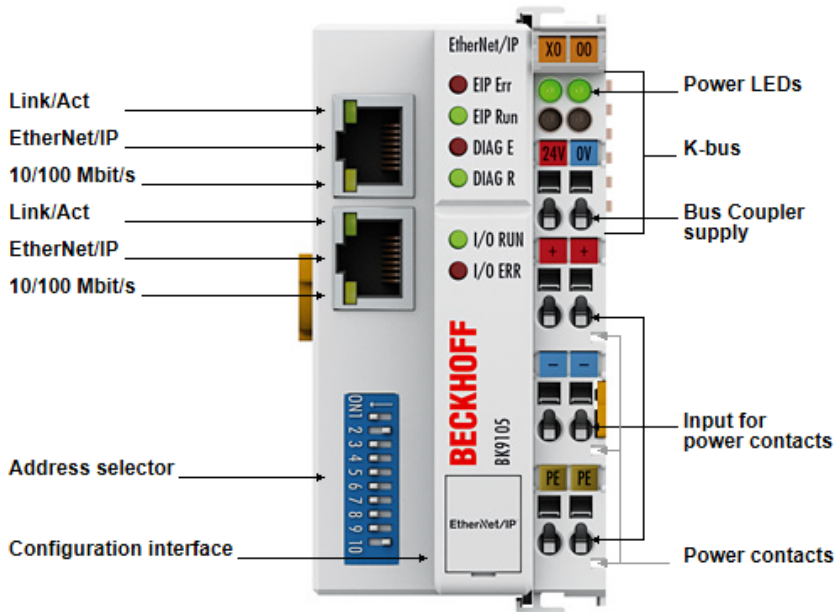

Fig. 2: BK9105

The BK9105 Bus Coupler connects EtherNet/IP with the modular, extendable electronic terminal blocks. One unit consists of one Bus Coupler, any number from 1 to 64 terminals (255 with K-bus extension) and one end terminal.

The Bus Coupler recognizes the terminals to which it is connected, and performs the assignment of the inputs and outputs to the words of the process image automatically. The BK9105 Bus Coupler supports 10 Mbit/s and 100 Mbit/s Ethernet. Connection is through normal RJ 45 connectors. The IP address is set on the DIP switch (offset to a freely selectable start address). In networks with DHCP (a service for the allocation of the logical IP address to the physical node address [MAC-ID]) the Bus Coupler obtains its IP address from the DHCP server.

The BK9105 contains a 3-port switch. Two ports operate external on RJ 45 connectors and can be utilized. The I/O stations can thus be configured with a line topology, instead of the classic star topology. In many applications this significantly reduces the wiring effort and the cabling costs. The maximum distance between two couplers is 100 m. Up to 20 BK9105 Bus Couplers are cascable, so that a maximum line length of 2 km can be achieved.

Ethernet/IP is the Industrial Ethernet standard of ODVA (Open DeviceNet Vendor Association). Ethernet/IP is based on Ethernet TCP/IP and UDP/IP – IP stands for Industrial Protocol. Essentially, the CIP (Common Industrial Protocol) used in ControlNet and DeviceNet was ported to Ethernet TCP/IP and UDP/IP.

Complex signal processing for analog I/Os, position measurement ...

The BK9105 Bus Coupler supports the operation of all Bus Terminal types.

The analog and multi-functional Bus Terminals can be adapted to each specific application using the KS2000 configuration set. Depending on the type, the analog Bus Terminals' registers contain temperature ranges, gain values and linearization characteristics. With the KS2000, the required parameters can be set on a PC. The Bus Terminals store settings permanently and in a fail-safe manner.

Optionally, the Bus Terminals can also be controlled by the control system. Via function blocks (FBs), the programmable logic controller (PLC) or the Industrial PC (IPC) handle configuration of the complete periphery during the start-up phase. If required, the controller can upload the decentrally created configuration data in order to centrally manage and store this data. Therefore, new adjustments are not necessary in the event of replacement of a Bus Terminal. The controller carries out the desired setting automatically after switching on.

2.3 Technical data

Technical data	BK9055	BK9105
Number of Bus Terminals	64 (255 with K-Bus extension)	64
Digital peripheral signals	3,936 Inputs/Outputs	
Analog peripheral signals	122 Inputs/Outputs	
Protocol	EtherNet/IP	
Configuration possibility	Via the KS2000 configuration software or the controller (TwinCAT)	
Maximum number of bytes	492 bytes of input and 492 bytes of output data	
Bus connection	1 x RJ45	2 x RJ45 (2 Port Switch)
Power supply	24 V _{DC} (-15%/+20%)	
Input current	70 mA + (total K-Bus current)/4, 500 mA max.	
Starting current	app. 2.5 x continuous current	
Recommended fuse	≤ 10 A	
K-Bus power supply up to	1750 mA	
Power contact voltage	max. 24 V _{DC}	
Power contact current load	max. 10 A	
Dielectric strength	500 V (power contact / supply voltage / fieldbus)	
Weight	app. 100 g	app. 170 g
Assembly	on 35 mm mounting rail according to EN 60715	
Permissible ambient temperature (operation)	0°C ... +55°C	-25°C ... +60°C
Permissible ambient temperature (storage)	-25 °C ... +85°C	-40 °C ... +85°C
Permissible relative humidity	95%, no condensation	
Vibration / shock resistance	conforms to EN 60068-2-6 / EN 60068-2-27	
EMC resistance burst / ESD	conforms to EN 61000-6-2 / EN 61000-6-4	
Installation position	variable	
Protection class	IP20	
Approvals	CE, UL, ATEX [▶ 18]	CE, UL, ATEX [▶ 19], GL

System

System data	EtherNet/IP
Number of I/O modules	only limited by the IP address space
Number of I/O points	depending on the controller
Data transfer medium	twisted pair copper cable, 4 x 2, shielded, category 5 (100 Mbit/s), category 3 (10 Mbit/s)
Distance between modules	100 m
Data transfer rate	10/100 Mbit/s
Topology	BK9055: star wiring BK9105: line or star wiring
Cascading	up to 20 BK9105 or max. line length 2 km

2.4 The Beckhoff Bus Terminal system

Up to 256 Bus Terminals, with 1 to 16 I/O channels per signal form

The Bus Terminal system is the universal interface between a fieldbus system and the sensor / actuator level. A unit consists of a Bus Coupler as the head station, and up to 64 electronic series terminals, the last one being an end terminal. Up to 255 Bus Terminals can be connected via the K-bus extension. For each

technical signal form, terminals are available with one, two, four or eight I/O channels, which can be mixed as required. All the terminal types have the same mechanical construction, so that difficulties of planning and design are minimized. The height and depth match the dimensions of compact terminal boxes.

Decentralised wiring of each I/O level

Fieldbus technology allows more compact forms of controller to be used. The I/O level does not have to be brought to the controller. The sensors and actuators can be wired decentrally, using minimum cable lengths. The controller can be installed at any location within the plant.

Industrial PCs as controllers

The use of an Industrial PC as the controller means that the operating and observing element can be implemented in the controller's hardware. The controller can therefore be located at an operating panel, in a control room, or at some similar place. The Bus Terminals form the decentralised input/output level of the controller in the control cabinet and the subsidiary terminal boxes. The power sector of the plant is also controlled over the bus system in addition to the sensor/actuator level. The Bus Terminal replaces the conventional series terminal as the wiring level in the control cabinet. The control cabinet can have smaller dimensions.

Bus Couplers for all usual bus systems

The Beckhoff Bus Terminal system unites the advantages of a bus system with the possibilities of the compact series terminal. Bus Terminals can be driven within all the usual bus systems, thus reducing the controller parts count. The Bus Terminals then behave like conventional connections for that bus system. All the performance features of the particular bus system are supported.

Mounting on standardized mounting rails

The installation is standardized thanks to the simple and space-saving mounting on a standardized mounting rail (EN 60715, 35 mm) and the direct wiring of actuators and sensors, without cross connections between the terminals. The consistent labelling scheme also contributes.

The small physical size and the great flexibility of the Bus Terminal system allow it to be used wherever a series terminal is also used. Every type of connection, such as analog, digital, serial or the direct connection of sensors can be implemented.

Modularity

The modular assembly of the terminal strip with Bus Terminals of various functions limits the number of unused channels to a maximum of one per function. The presence of two channels in one terminal is the optimum compromise of unused channels and the cost of each channel. The possibility of electrical isolation through potential feed terminals also helps to keep the number of unused channels low.

Display of the channel state

The integrated LEDs show the state of the channel at a location close to the sensors and actuators.

K-bus

The K-bus is the data path within a terminal strip. The K-bus is led through from the Bus Coupler through all the terminals via six contacts on the terminals' side walls. The end terminal terminates the K-bus. The user does not have to learn anything about the function of the K-bus or about the internal workings of the terminals and the Bus Coupler. Many software tools that can be supplied make project planning, configuration and operation easy.

Potential feed terminals for isolated groups

The operating voltage is passed on to following terminals via three power contacts. You can divide the terminal strip into arbitrary isolated groups by means of potential feed terminals. The potential feed terminals play no part in the control of the terminals, and can be inserted at any locations within the terminal strip.

Up to 64 Bus Terminals can be used in a terminal block, with optional K-bus extension for up to 256 Bus Terminals. This count does include potential feed terminals, but not the end terminal.

Bus Couplers for various fieldbus systems

Various Bus Couplers can be used to couple the electronic terminal strip quickly and easily to different fieldbus systems. It is also possible to convert to another fieldbus system at a later time. The Bus Coupler performs all the monitoring and control tasks that are necessary for operation of the connected Bus Terminals. The operation and configuration of the Bus Terminals is carried out exclusively by the Bus Coupler. Nevertheless, the parameters that have been set are stored in each Bus Terminal, and are retained in the event of voltage drop-out. Fieldbus, K-bus and I/O level are electrically isolated.

If the exchange of data over the fieldbus is prone to errors or fails for a period of time, register contents (such as counter states) are retained, digital outputs are cleared, and analog outputs take a value that can be configured for each output when commissioning. The default setting for analog outputs is 0 V or 0 mA. Digital outputs return in the inactive state. The timeout periods for the Bus Couplers correspond to the usual settings for the fieldbus system. When converting to a different bus system it is necessary to bear in mind the need to change the timeout periods if the bus cycle time is longer.

The interfaces

A Bus Coupler has six different methods of connection. These interfaces are designed as plug connectors and as spring-loaded terminals.

2.5 Ethernet

Ethernet was originally developed by DEC, Intel and XEROX (as the "DIX" standard) for passing data between office devices. The term nowadays generally refers to the *IEEE 802.3 CSMA/CD* specification, published in 1985. Because of the high acceptance around the world this technology is available everywhere and is very economical. This means that it is easy to make connections to existing networks.

There are now a number of quite different transmission media: coaxial cable (10Base5), optical fiber (10BaseF) or twisted pairs (10BaseT) with screen (STP) or without screen (UTP). Using Ethernet, different topologies can be built such as ring, line or star.

Ethernet transmits Ethernet packets from a sender to one or more receivers. This transmission takes place without acknowledgement, and without the repetition of lost packets. To achieve reliable data communication, there are protocols, such as TCP/IP, that can run on top of Ethernet.

Basic principles

The Internet Protocol (IP)

The internet protocol (IP) forms the basis of this data communication. IP transports data packets from one device to another; the devices can be in the same network, or in different networks. IP here looks after the address management (finding and assigning MAC-IDs), segmentation and routing. Like the Ethernet protocol, IP does not guarantee that the data is transported - data packets can be lost, or their sequence can be changed.

TCP/IP was developed to provide standardised, reliable data exchange between any numbers of different networks. TCP/IP was developed to provide standardised, reliable data exchange between any numbers of different networks. Although the term is often used as if it were a single concept, a number of protocols are layered together: e.g. IP, TCP, UDP, ARP and ICMP.

Transmission Control Protocol (TCP)

The Transmission Control Protocol (TCP) which runs on top of IP is a connection-oriented transport protocol. It includes error detection and handling mechanisms. Lost telegrams are repeated.

User Datagram Protocol (UDP)

UDP is connectionless transport protocol. It provides no control mechanism when exchanging data between sender and receiver. This results in a higher processing speed than, for example, TCP. Checking whether or not the telegram has arrived must be carried out by the higher-level protocol.

Internet Control Message Protocol (ICMP)

It is used by end devices, to exchange information about the current status of the internet protocol.

Address Resolution Protocol (ARP)

Performs conversion between the IP addresses and MAC addresses.

BootP

The BootP protocol allows the TCP/IP address to be set or altered, by addressing the network device with its MAC-ID.

3 Mounting and wiring

3.1 Dimensions

The system of the Beckhoff Bus Terminals is characterized by low physical volume and high modularity. When planning a project it must be assumed that at least one Bus Coupler and a number of Bus Terminals will be used. The mechanical dimensions of the Bus Couplers are independent of the fieldbus system.

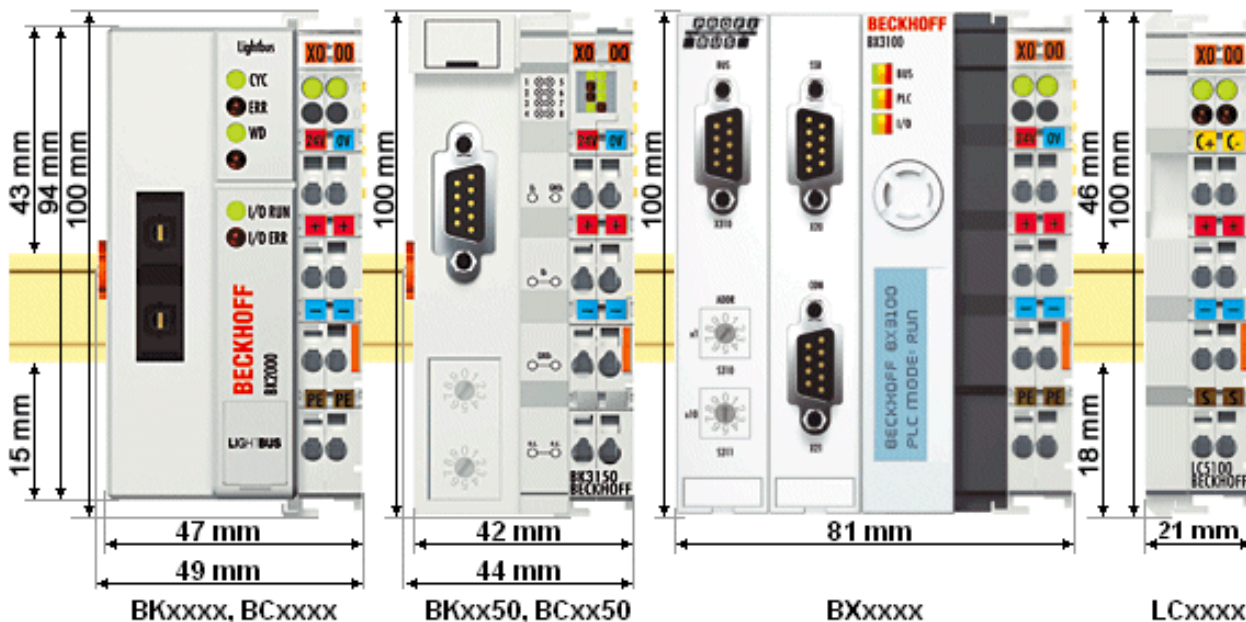

Fig. 3: Dimensions

The total width in practical cases is composed of the width of the Bus Coupler, the KL9010 Bus End Terminal and the width of the bus terminals in use. Depending on function, the Bus Terminals are 12 or 24 mm wide. The front wiring increases the total height of 68 mm by about 5 to 10 mm, depending on the wire thickness.

Mechanical data	BKxxxx BCxxxx	BKxx50 BCxx50	BXxxxx	LCxxxx
Design form	compact terminal housing with signal LED			
Material	Polyamide (PA 6.6)	Polyamide (PA 6.6)	Polycarbonate	Polyamide (PA 6.6)
Dimensions (W x H x D)	49 x 100 x 68 mm	44 x 100 x 68 mm	81 (BX8000 61) x 100 x 89 mm	21 x 100 x 68 mm
Mounting	on 35 mm C-rail in accordance with EN 60715 with latching			
Stackable by	Double groove-tongue connection			
Labelling	Standard terminal block labelling			
Vibration/shock resistance	conforms to EN 60068-2-6 / EN 60068-2-27			
EMC immunity/emission	conforms to EN 61000-6-2 / EN 61000-6-4			

Connection technology	BKxxxx BCxxxx	BKxx50 BCxx50	BXxxxx	LCxxxx
Wiring	Cage Clamp® spring-loaded system			
Connection cross-section	0.08 mm ² ... 2.5 mm ² , stranded, solid wire, 28-14 AWG			
Fieldbus connection	depending on fieldbus		spring-loaded terminals	
Power contacts	3 spring contacts			
Current loading IMAXX	10 A (125 A short circuit)			
Rated voltage	24 V _{DC}			

3.2 Installation on mounting rails

⚠ WARNING

Risk of injury through electric shock and damage to the device!

Bring the Bus Terminals system into a safe, de-energized state before starting mounting, disassembly or wiring of the Bus Terminals.

Mounting

The Bus Couplers and Bus Terminals are attached to commercially available 35 mm mounting rails (DIN rail according to EN 60715) by applying slight pressure:

1. First attach the Fieldbus Coupler to the mounting rail.
2. The Bus Terminals are now attached on the right-hand side of the fieldbus Coupler. Join the components with slot and key and push the terminals against the mounting rail, until the lock clicks onto the mounting rail.

If the terminals are clipped onto the mounting rail first and then pushed together without tongue and groove, the connection will not be operational! When correctly assembled, no significant gap should be visible between the housings.

● Fixing of mounting rails

i The locking mechanism of the terminals and couplers extends to the profile of the mounting rail. At the installation, the locking mechanism of the components must not come into conflict with the fixing bolts of the mounting rail. To mount the mounting rails with a height of 7.5 mm under the terminals and couplers, you should use flat mounting connections (e.g. countersunk screws or blind rivets).

Disassembly

Each terminal is secured by a lock on the mounting rail, which must be released for disassembly:

1. Carefully pull the orange-colored lug approximately 1 cm out of the terminal to be disassembled, until it protrudes loosely. The lock with the mounting rail is now released for this terminal, and the terminal can be pulled from the mounting rail without excessive force.
2. Grasp the released terminal with thumb and index finger simultaneous at the upper and lower grooved housing surfaces and pull the terminal away from the mounting rail.

Connections within a Bus Terminal block

The electric connections between the Bus Coupler and the Bus Terminals are automatically realized by joining the components:

- The six spring contacts of the K-Bus/E-Bus deal with the transfer of the data and the supply of the Bus Terminal electronics.
- The power contacts deal with the supply for the field electronics and thus represent a supply rail within the Bus Terminal block. The power contacts are supplied via terminals on the Bus Coupler.

● Power contacts

i During the design of a Bus Terminal block, the pin assignment of the individual Bus Terminals must be taken account of, since some types (e.g. analog Bus Terminals or digital 4-channel Bus Terminals) do not or not fully loop through the power contacts. Power Feed Terminals (KL91xx, KL92xx and EL91xx, EL92xx) interrupt the power contacts and thus represent the start of a new supply rail.

PE power contact

The power contact labelled PE can be used as a protective earth. For safety reasons this contact mates first when plugging together, and can ground short-circuit currents of up to 125 A.

NOTE

Risk of damage to the device

Note that, for reasons of electromagnetic compatibility, the PE contacts are capacitatively coupled to the mounting rail. This may lead to incorrect results during insulation testing or to damage on the terminal (e.g. disruptive discharge to the PE line during insulation testing of a consumer with a nominal voltage of 230 V). For insulation testing, disconnect the PE supply line at the Bus Coupler or the Power Feed Terminal! In order to decouple further feed points for testing, these Power Feed Terminals can be released and pulled at least 10 mm from the group of terminals.

⚠ WARNING

Risk of electric shock!

The PE power contact must not be used for other potentials!

Wiring

Up to eight connections enable the connection of solid or finely stranded cables to the Bus Terminals. The terminals are implemented in spring force technology. Connect the cables as follows:

1. Open a spring-loaded terminal by slightly pushing with a screwdriver or a rod into the square opening above the terminal.
2. The wire can now be inserted into the round terminal opening without any force.
3. The terminal closes automatically when the pressure is released, holding the wire safely and permanently.

● Shielding

i Analog sensors and actuators should always be connected with shielded, pair-wise twisted cables.

3.3 Power supply, potential groups

Power supply for the Bus Coupler

The Bus Couplers require a 24 V_{DC} supply for their operation. The connection is made by means of the upper spring-loaded terminals labelled 24 V and 0 V. The supply voltage feeds the Bus Coupler electronics and, over the K-Bus/E-Bus, the Bus Terminals. The power supply for the Bus Coupler electronics and that of the K-Bus/E-Bus are electrically separated from the potential of the field level.

Power supply for the power contacts

The bottom six connections with spring-loaded terminals can be used to feed the supply for the peripherals. The spring-loaded terminals are joined in pairs to a power contact. The feed for the power contacts has no connection to the voltage supply for the Bus Coupler. The design of the feed permits voltages of up to 24 V. The assignment in pairs and the electrical connection between feed terminal contacts allows the connection wires to be looped through to various terminal points. The current drawn from the power contacts must not exceed 10 A for long periods. The current carrying capacity between two spring-loaded terminals is identical to that of the connecting wires.

Power contacts

On the right hand face of the Bus Coupler there are three spring contacts for the power contact connections. The spring contacts are hidden in slots so that they cannot be accidentally touched. By attaching a Bus Terminal the blade contacts on the left hand side of the Bus Terminal are connected to the spring contacts. The tongue and groove guides on the top and bottom of the Bus Coupler and of the Bus Terminals guarantees that the power contacts mate securely.

Configuration interface (not for BK1250, EK1x00)

The standard Bus Couplers have an RS232 interface at the bottom of the front face. The miniature connector can be joined to a PC with the aid of a connecting cable and the KS2000 configuration software. The interface permits the Bus Terminals to be configured, for example adjusting the amplification factors of the analog channels. The interface can also be used to change the assignments of the bus terminal data to the process image in the Bus Coupler. The functionality of the configuration interface can also be reached via the fieldbus using string communication facility.

Electrical isolation

The bus couplers operate by means of three independent potential groups. The supply voltage feeds the K-Bus/E-Bus electronics in the Bus Coupler and the K-Bus/E-Bus itself in an electrically isolated manner. The supply voltage is also used to generate the operating voltage for the fieldbus.

Note: All Bus Terminals are electrically isolated from the K-Bus/E-bus. The K-Bus/E-bus is therefore completely electrically isolated.

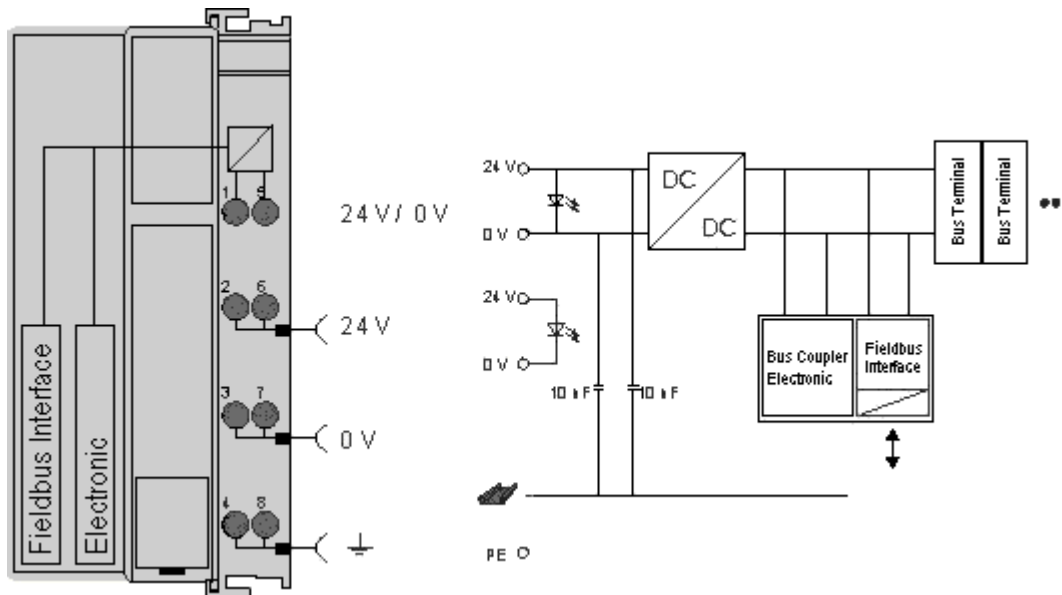

Fig. 4: Electrical isolation

3.4 ATEX - Special conditions (standard temperature range)

⚠ WARNING

Observe the special conditions for the intended use of Beckhoff fieldbus components with standard temperature range in potentially explosive areas (directive 2014/34/EU)!

- The certified components are to be installed in a suitable housing that guarantees a protection class of at least IP54 in accordance with EN 60079-15! The environmental conditions during use are thereby to be taken into account!
- If the temperatures during rated operation are higher than 70°C at the feed-in points of cables, lines or pipes, or higher than 80°C at the wire branching points, then cables must be selected whose temperature data correspond to the actual measured temperature values!
- Observe the permissible ambient temperature range of 0 to 55°C for the use of Beckhoff fieldbus components standard temperature range in potentially explosive areas!
- Measures must be taken to protect against the rated operating voltage being exceeded by more than 40% due to short-term interference voltages!
- The individual terminals may only be unplugged or removed from the Bus Terminal system if the supply voltage has been switched off or if a non-explosive atmosphere is ensured!
- The connections of the certified components may only be connected or disconnected if the supply voltage has been switched off or if a non-explosive atmosphere is ensured!
- The fuses of the KL92xx/EL92xx power feed terminals may only be exchanged if the supply voltage has been switched off or if a non-explosive atmosphere is ensured!
- Address selectors and ID switches may only be adjusted if the supply voltage has been switched off or if a non-explosive atmosphere is ensured!

Standards

The fundamental health and safety requirements are fulfilled by compliance with the following standards:

- EN 60079-0:2012+A11:2013
- EN 60079-15:2010

Marking

The Beckhoff fieldbus components with standard temperature range certified according to the ATEX directive for potentially explosive areas bear one of the following markings:



II 3G KEMA 10ATEX0075 X Ex nA IIC T4 Gc Ta: 0 ... +55°C

or



II 3G KEMA 10ATEX0075 X Ex nC IIC T4 Gc Ta: 0 ... +55°C

3.5 ATEX - Special conditions (extended temperature range)

⚠ WARNING

Observe the special conditions for the intended use of Beckhoff fieldbus components with extended temperature range (ET) in potentially explosive areas (directive 2014/34/EU)!

- The certified components are to be installed in a suitable housing that guarantees a protection class of at least IP54 in accordance with EN 60079-15! The environmental conditions during use are thereby to be taken into account!
- If the temperatures during rated operation are higher than 70°C at the feed-in points of cables, lines or pipes, or higher than 80°C at the wire branching points, then cables must be selected whose temperature data correspond to the actual measured temperature values!
- Observe the permissible ambient temperature range of -25 to 60°C for the use of Beckhoff fieldbus components with extended temperature range (ET) in potentially explosive areas!
- Measures must be taken to protect against the rated operating voltage being exceeded by more than 40% due to short-term interference voltages!
- The individual terminals may only be unplugged or removed from the Bus Terminal system if the supply voltage has been switched off or if a non-explosive atmosphere is ensured!
- The connections of the certified components may only be connected or disconnected if the supply voltage has been switched off or if a non-explosive atmosphere is ensured!
- The fuses of the KL92xx/EL92xx power feed terminals may only be exchanged if the supply voltage has been switched off or if a non-explosive atmosphere is ensured!
- Address selectors and ID switches may only be adjusted if the supply voltage has been switched off or if a non-explosive atmosphere is ensured!

Standards

The fundamental health and safety requirements are fulfilled by compliance with the following standards:

- EN 60079-0:2012+A11:2013
- EN 60079-15:2010

Marking

The Beckhoff fieldbus components with extended temperature range (ET) certified according to the ATEX directive for potentially explosive areas bear the following marking:



II 3G KEMA 10ATEX0075 X Ex nA IIC T4 Gc Ta: -25 ... +60°C

or



II 3G KEMA 10ATEX0075 X Ex nC IIC T4 Gc Ta: -25 ... +60°C

3.6 ATEX Documentation



Notes about operation of the Beckhoff terminal systems in potentially explosive areas (ATEX)

Pay also attention to the continuative documentation

Notes about operation of the Beckhoff terminal systems in potentially explosive areas (ATEX)

that is available in the download area of the Beckhoff homepage <http://www.beckhoff.com>!

4 Parametrization and commissioning

4.1 Start-up behaviour of the Bus Coupler

Immediately after being switched on, the Bus Coupler checks, in the course of a self-test, all the functions of its components and the communication on the K-bus/E-bus. The red I/O LED blinks while this is happening. After completion of the self-test, the Bus Coupler starts to test the attached Bus Terminals (the "Bus Terminal Test"), and reads in the configuration. The Bus Terminal configuration is used to generate an internal structure list, which is not accessible from outside. In case of an error, the Bus Coupler enters the *Stop* state. Once the start-up has completed without error, the Bus Coupler enters the *fieldbus start* state.

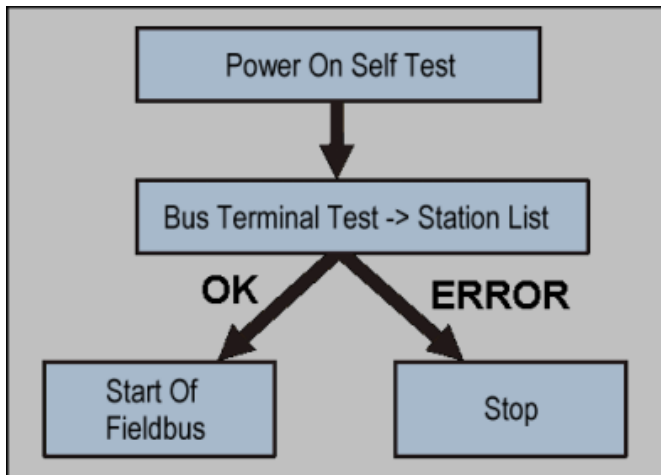

Fig. 5: Start-up behaviour of the Bus Coupler

The Bus Coupler can be made to enter the normal operating state by switching it on again once the fault has been rectified.

4.2 Parameterization of the Bus Coupler using DIP Switches*

*) Firmware version B5 or higher

The following parameterizations can be carried out without using configuration software, with the aid of the DIP switches and the end terminal (KL9010).

This parameterization mode is only active if only one end terminal (KL9010) is inserted. Otherwise, the normal settings apply.

Restoring the manufacturer's settings

- Switch off the Bus Coupler, and plug in just the end terminal (KL9010).
- Set all the DIP switches to ON, and switch the Bus Coupler on again.
- Once the default parameters have successfully been set, the *Error* LED lights, and the *I/O Run* and *I/O Error* LEDs flash alternately.
- You can then switch the Bus Coupler off, connect the Bus Terminals, and continue as usual.

Setting the Ethernet parameters

- Switch off the Bus Coupler, and plug in just the end terminal (KL9010).
- Set all the DIP switches to OFF, and switch the Bus Coupler on again.
- The *I/O RUN* and *I/O Error* LEDs light steadily.
- Make the desired setting in accordance with the following table.

DIP switch	Parameters	Selection	Setting	Comment
1	Baud Rate	10 MBaud	OFF (0)	
		100 MBaud	ON (1)	Default
2	Auto-Baud-Rate	Disable	OFF (0)	
		Enable	ON (1)	Default
3	Transmission type	Half duplex	OFF (0)	
		Full duplex	ON (1)	Default

- To accept the values, set DIP switch 10 to ON.
By flashing the *I/O RUN* and *I/O ERR* LEDs the Bus Coupler indicates that it has accepted the parameters.
- You can then switch the Bus Coupler off, connect the Bus Terminals, and continue as usual.

4.3 Network classes

Three different network classes are distinguished. They determine how many address bits are reserved for the network ID and how many for the node number (e.g. for PCs or Bus Couplers). The difference is located in the first three bits of the IP address.

Network class	Number of bits for the network ID	Enables no. of networks	No. of bits for the node address	Enables no. of nodes per network
A	7	126	24	16 777 214
B	14	16 382	16	65 536
C	21	2 097 150	8	254

i Unique IP address

An IP address must be unique within the entire connected network!

Network class A, Addresses: 1.xxx.xxx.xxx - 126.xxx.xxx.xxx

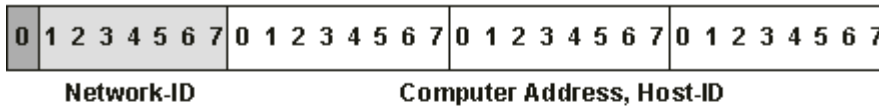

Network class B, Addresses: 128.0.xxx.xxx - 191.255.xxx.xxx

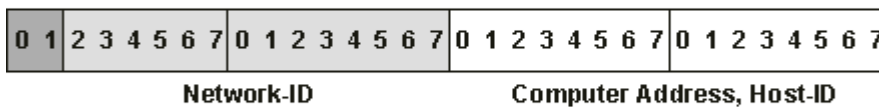

Network class C, Addresses: 192.0.0.xxx - 223.255.255.xxx

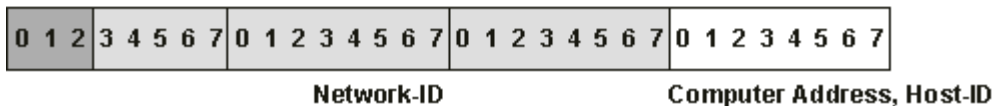

Fig. 6: Network classes

i Identical network class

In a communication with another Ethernet devices, the IP address set must have the same network class. Sample: Your PC has the address 172.16.17.55, which means the coupler must have the address 172.16.xxx.xxx (xxx stands for a number between 0 and 255. 0 is usually used by the router/switch and should therefore remain reserved).

In order to see the PC's own address, the command *ipconfig* can be entered into a DOS window under Windows NT/2000/XP.

4.4 IP address

The IP address can be set using four different procedures, and these will be described in more detail below.

Procedure	Explanation	Necessary components
KS2000	Addressing using the KS2000 configuration software and DIP switches	KS2000 configuration software and KS2000 cable
ARP	Addressing via the ARP table [▶ 24]	PC with network
BootP	Addressing via BootP server [▶ 25]	BootP server
DHCP	Addressing via DHCP server	DHCP server

4.4.1 Configuration with KS2000

The KS2000 configuration software (from version 3.2.8) can be used to set the TCP/IP address in a dialog box, or it can be written directly into the registers. DIP switches 9 and 10 (for BK9050 DIP switches 1 and 2 in blue) should both be OFF (0) before switching on.

Table 100

Register	High-Byte	Low-Byte
0	IP-Byte 2	IP-Byte 1
1	Not used	IP-Byte 3

Default

Byte	Default value (hex)	Default value (dec)
1	0xAC	172 _{dec}
2	0x10	16 _{dec}
3	0x11	17 _{dec}
4	(DIP switch)	(0 to 255 _{dec})

Sample



Fig. 7: DIP switch

Switch no.	1	2	3	4	5	6	7	8	9	10	
Valence	1	2	4	8	16	32	64	128	-	-	
In this example	ON	OFF	OFF	ON	OFF	OFF	ON	ON	OFF	OFF	
Value	1	0	0	8	0	0	64	128	-	-	Total=201

● Software reset

i A software reset is required to save changes in the Bus Coupler tables. A hardware reset (power on/off) is not sufficient!

4.4.2 Address Configuration via ARP

An easy method of modifying the IP address is to set the address using the DOS window. It is, however, only possible to alter addresses within the same network class. The new IP address that has been set remains stored even after the Bus Coupler has been switched off.

Procedure

- Set DIP switches 9 and 10 to OFF. DIP switches 1-8 then no longer have any address function.
- Open a DOS box on your PC.
- Enter the command "ping <OLD IP address>" to create an entry in the ARP table.
- Read the table with the command "ARP -a".
- Enter "ARP -d <OLD IP address>" to remove the Bus Coupler from the table.
- Use "ARP -s <NEW IP address> <MAC-ID> [▶ 30]" to make an entry manually.
- With "ping -l 123 <NEW IP address>" the new IP address becomes valid.

A short flash from the ERROR LED at the moment of switching on indicates that the Bus Coupler is being addressed by ARP, and that DIP switches 1-8 give no indication of the address that is set.

● Changing the IP address

i When the IP address is changed, all the dynamic ARP entries should be cleared. To change the IP address it is one ping with the length of 123 bytes is permitted for reconfiguration of the IP address (<ping -l "IP address">) necessary.

Example

1. C:>ping 172.16.17.255
2. C:>arp -a
172.16.17.255 00-01-05-00-11-22
3. C:>arp -d 172.16.17.255
4. C:>arp -s 172.16.44.44 00-01-05-00-11-22
5. C:>ping -l 123 172.16.44.44

4.4.3 Address configuration via BootP server

4.4.3.1 Addressing via Beckhoff BootP Server

● BootP Server

i Disable all other Ethernet adapter in your “network connections” before you start the BootP Server. You have then only one Ethernet adapter which you can use for BootP.

Connecting to the BootP Server

BootP server:

https://download.beckhoff.com/download/software/TwinCAT/TwinCAT2/Unsupported_Utilities/TcBootP_Server/

How to use the BootP server

Use the BootP server with the BK9105 in one of two ways:

1. Statically store an IP address by switching all the dip switches 1-9 to the on position

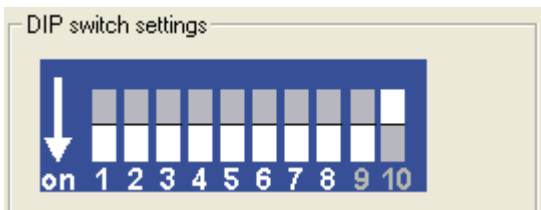

Fig. 8: Beckhoff BootP Server - DIP switch settings for statically stored IP address

When choosing this mode, power cycling the BK9105 with the dip switches set to ON 1-9 will keep the IP address set by the BootP server. The BootP server does not need to be present after this point.

2. Dynamically set an IP address that is assigned by the BootP by turning on only dip switch 9

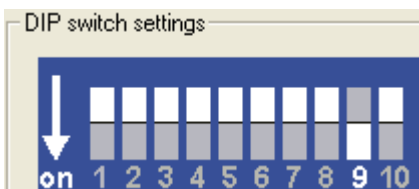

Fig. 9: Beckhoff BootP Server - DIP switch settings for dynamically set IP address

Be sure to configure the BootP server with the Mac ID of the BK9105 and the desired IP address.

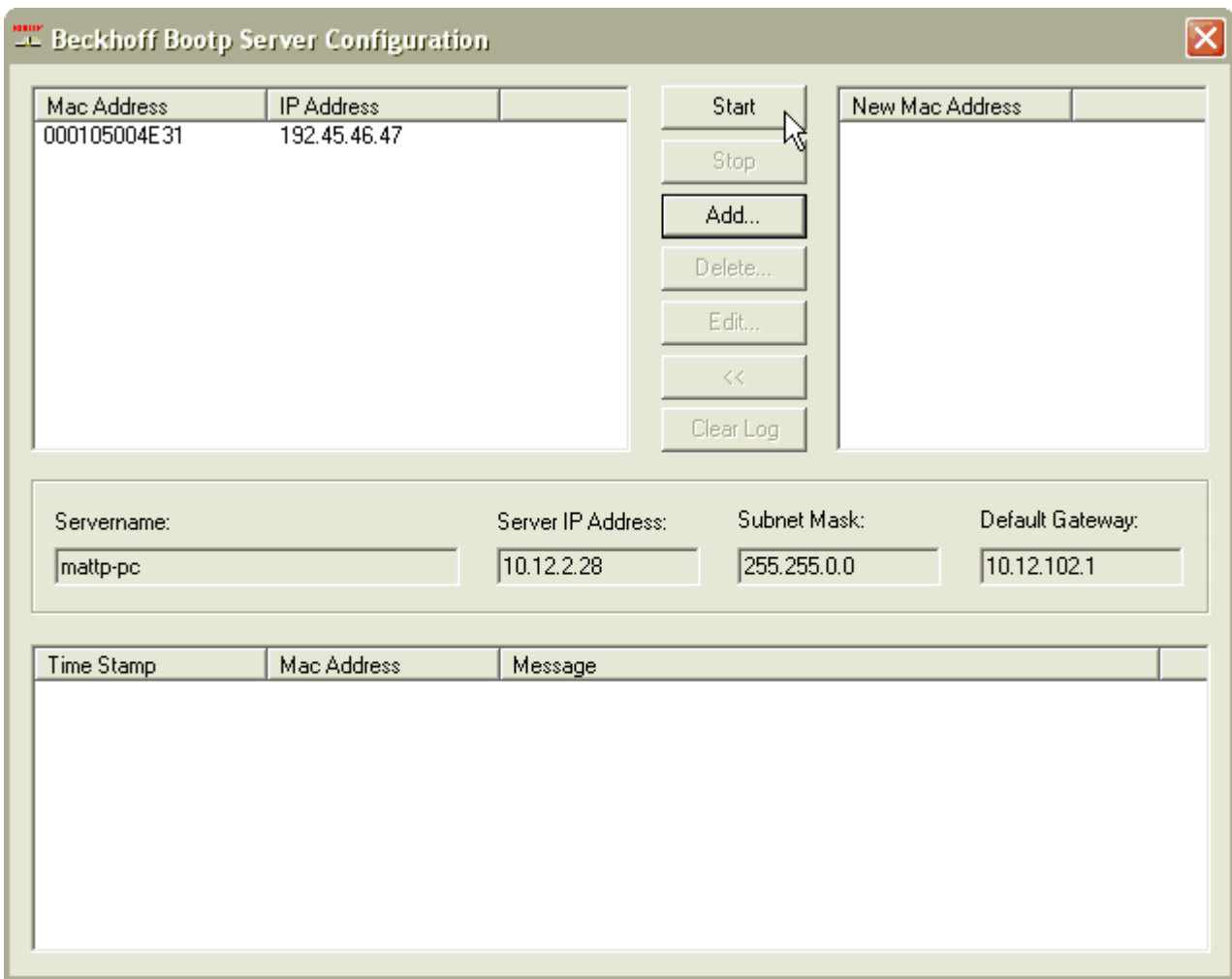

Fig. 10: Beckhoff BootP server configuration - Start

Then, start the server and reboot the BK9105. After a connection and an IP address are established, the following time stamp appears:

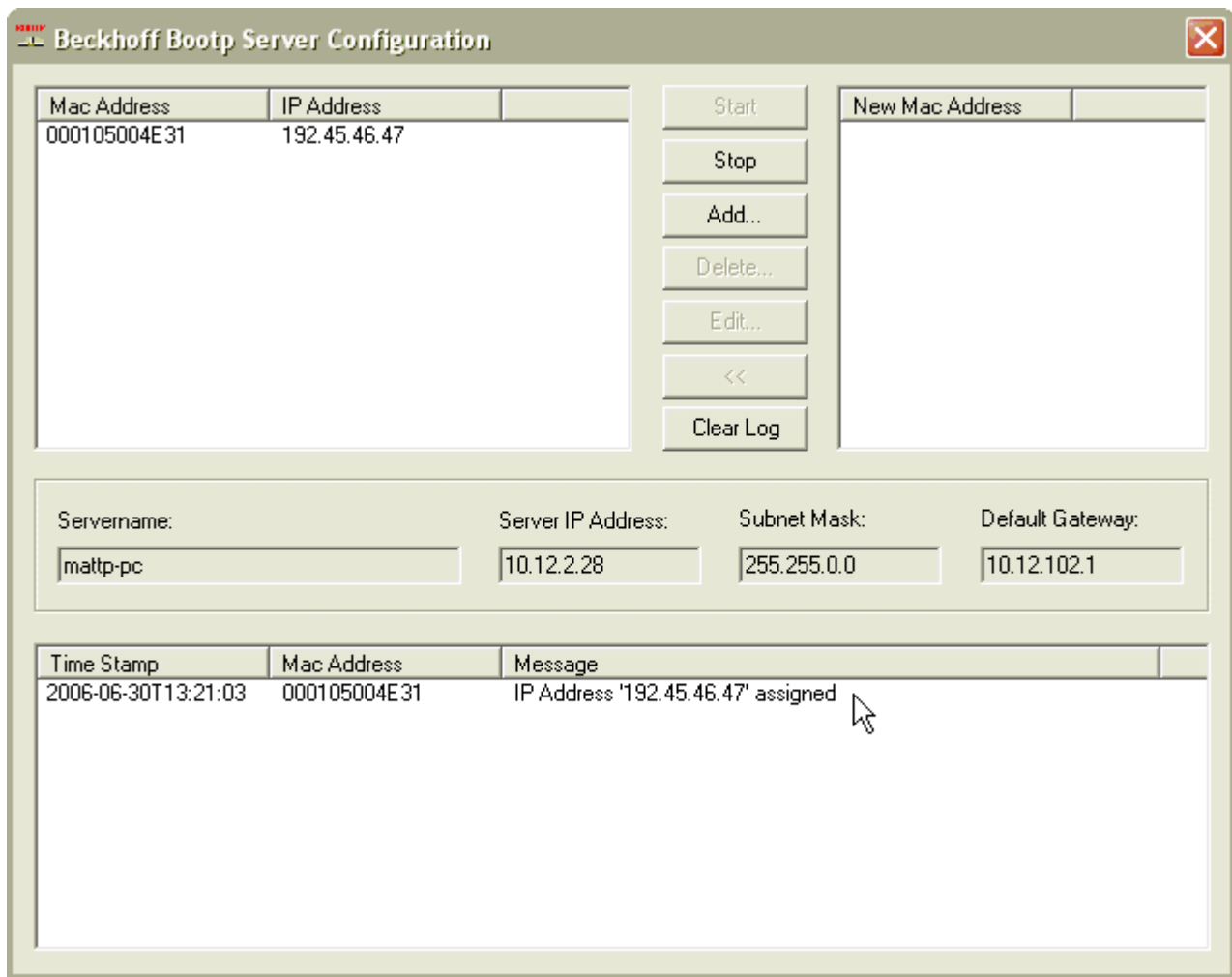

Fig. 11: Beckhoff BootP server configuration - Time Stamp

● Regard dip switch 9 for dynamically set IP address

i It is not possible to change dip switches 1 to 9 for a static IP address. They must remain on. If using the BootP server to assign the address every time the BK9105 is powered on, make sure dip switch 9 is on.

4.4.3.2 Addressing via Rockwell BOOTP/DHCP Server 2.3

IP address save modes

DIP switches 1 to 8 in the ON position

The address assigned by the BootP server is stored, and the BootP service will not be restarted after the next cold start.

The address can be cleared again by reactivating the manufacturers' settings (using the KS2000 software or with the DIP switch and end terminal [▶ 27]).

DIP switches 1 to 8 in the OFF position

The IP address assigned by the BootP server is only valid until the Bus Coupler is switched off. The BootP server must assign a new IP address to the Bus Coupler at the next cold start. The address is, however, retained through a software reset of the Bus Coupler

Switch the DIP Switch 1 to 8 ON or OFF and DIP 9-10 ON.

Take note that the dip switches 1 to 8 no longer hold any addressing capabilities.

The MAC Address begins with 00-01-05-xx-xx-xx (see under the BK9105 to find the MAC address).

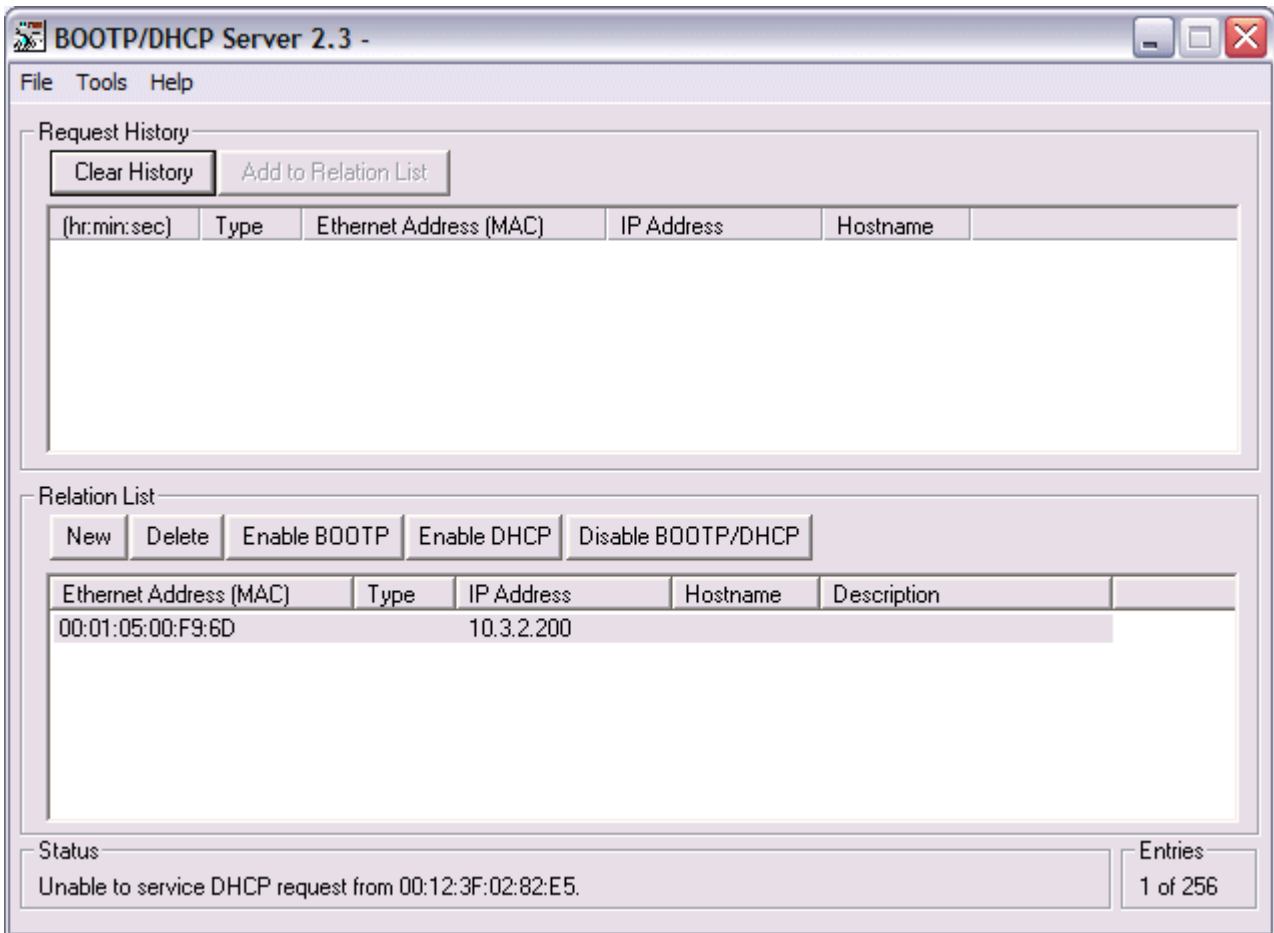

Fig. 12: Rockwell BOOTP/DHCP Server 2.3 - MAC address

After a successful addressing you can disable the BOOTP addressing.

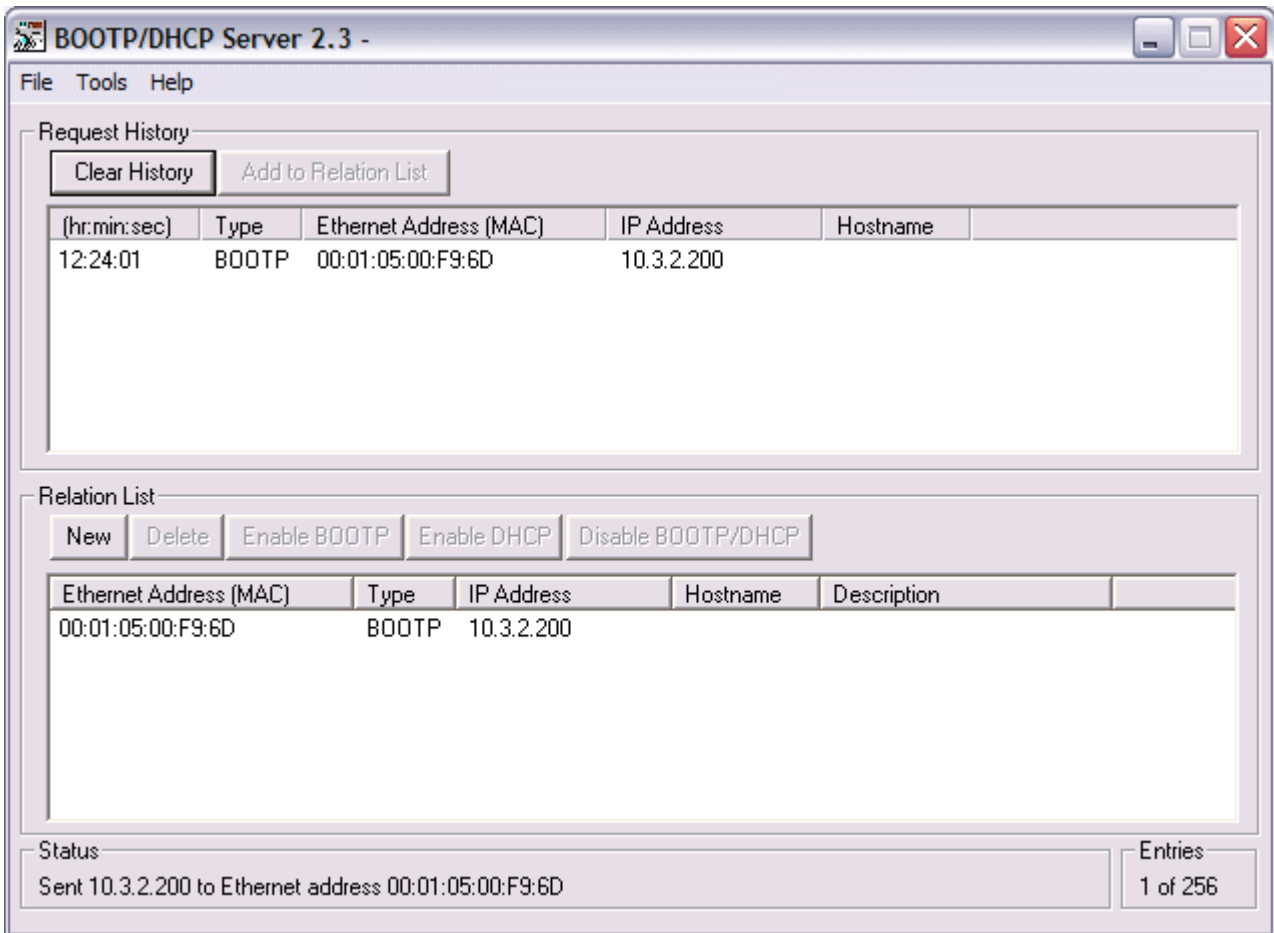

Fig. 13: Rockwell BOOTP/DHCP Server 2.3 - successful addressing

4.4.4 Setting the address using a DHCP server

To set the address by means of a DHCP server, set DIP switch 9 to OFF (0) and DIP switch 10 to ON (1).

In this state the DHCP service is switched on, and the Bus Coupler is assigned an IP address by the DHCP server.

The DHCP server must know the MAC ID of the Bus Coupler and should assign the same IP address to this MAC ID on each startup.

The *TCP/IP error* LED flashes while the address is being allocated.

4.4.5 Subnet mask

The subnet mask is subject to the control of the network administrator, and specifies the structure of the subnet.

Small networks without a router do not require a subnet mask. The same is true if you do not use registered IP numbers. A subnet mask can be used to subdivide the network with the aid of the mask instead of using a large number of network numbers.

The subnet mask is a 32-bit number:

- Ones in the mask indicate the subnet part of an address space.
- Zeros indicate that part of the address space which is available for the host IDs.

Description	Binary representation	Decimal representation
IP address	10101100.00010000.00010001.11001000	172.16.17.200
Subnet mask	11111111.11111111.00010100.00000000	255.255.20.0
Network ID	10101100.00010000.00010000.00000000	172.16.16.0
Host ID	00000000.00000000.00000001.11001000	0.0.1.200

Standard subnet mask

Address class	Standard subnet mask (decimal)	Standard subnet mask (hex)
A	255.0.0.0	FF.00.00.00
B	255.255.0.0	FF.FF.00.00
C	255.255.255.0	FF.FF.FF.00

i Subnets and host number

Neither subnet 0 nor the subnet consisting only of ones may be used. Neither host number 0 nor the host number consisting only of ones may be used!
 If the IP address is set using the KS2000 configuration software, it is necessary for the subnet mask also to be changed with the KS2000 configuration software.
 If ARP addressing is used, the associated standard subnet mask, based on the IP address, is entered.
 Under BootP or DHCP the subnet mask is transmitted also by the server.

4.4.6 Testing the IP address

To test the IP address you can use the *Ping* command in a Windows prompt.

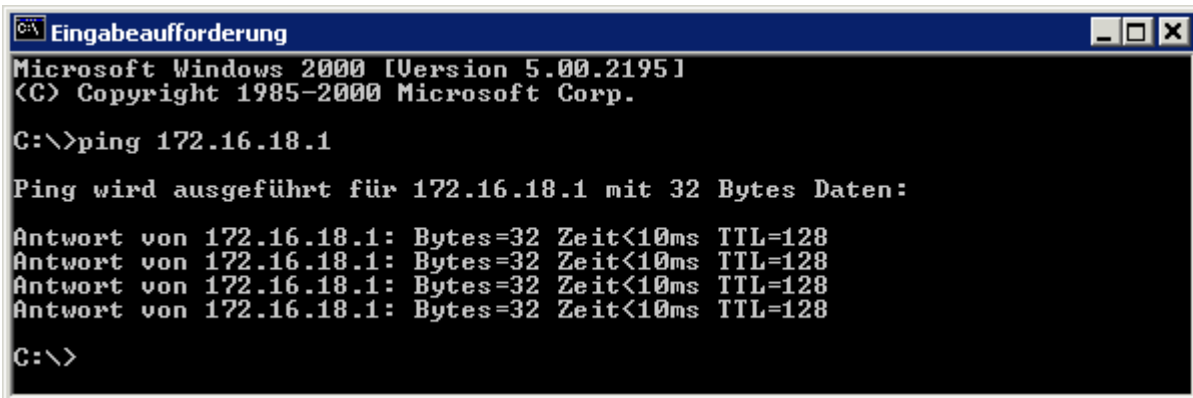

Fig. 14: Testing the IP address using the Ping command

4.4.7 Reading the MAC-ID

Proceed as follows to read the MAC-ID.

- Change the IP address on your PC to 172.16.x.x and the Subnet mask to 255.255.0.0
 The IP address when supplied by the manufacturer on the BC9000 and BK9000 is 172.16.17.255 (DIP switches 1 to 8 are set to ON).
 The IP address of the IP67 Fieldbus Boxes are set to 172.16.18.(rotary switch setting).
- Start the DOS Window
- Send a Ping to IP address 172.16.17.xxx
- Read the MAC-ID with *arp -a*.

4.5 Configuration

4.5.1 Mapping

Type: ETHERNET-MODULE Generic Ethernet Module
 Comm Format: SINT, INT or DINT

Assembly Instance:

- Input: 101 Size: 4 x SINT (BYTE) + terminals (2 x INT + terminals or 1 x DINT + terminals)
- Output: 102 Size: 4 x SINT (BYTE) + terminals (2 x INT + terminals or 1 x DINT + terminals)
- Configuration: 100 Size 0

Mapping rules

Complex terminals* (see documentation terminals)

- Word Alignment
- complex mapping

Comm Format: SINT

Offset	Inputs	Outputs
0	Status Byte 0	Control Byte 0
1	Status Byte 1	Control Byte 1
2	Status Byte 2	Control Byte 2
3	Status Byte 3	Control Byte 3
4...x	complex terminals*	complex terminals*
x...y	digital terminals**	digital terminals**

*) complex terminals, example KL15xx, KL25xx, KL3xxx, KI4xxx, KL5xxx, KL6xxx, KL8xxx

***) digital terminals, example KL1xxx, KL2xxx, KM1xxx, KM2xxx

Comm Format: INT

Offset	Inputs	Outputs
0	Status Word 0	Control Word 0
1	Status Word 1	Control Word 1
2...x	complex terminals*	complex terminals*
x...y	digital terminals**	digital terminals**

*) complex terminals, example KL15xx, KL25xx, KL3xxx, KI4xxx, KL5xxx, KL6xxx, KL8xxx

***) digital terminals, example KL1xxx, KL2xxx, KM1xxx, KM2xxx

Comm Format: DINT

Offset	Inputs	Outputs
0	Status DWord 0	Control DWord 0
1...x	complex terminals*	complex terminals*
x...y	digital terminals**	digital terminals**

*) complex terminals, example KL15xx, KL25xx, KL3xxx, KI4xxx, KL5xxx, KL6xxx, KL8xxx

***) digital terminals, example KL1xxx, KL2xxx, KM1xxx, KM2xxx

Mapping terminals

Example 1: (only digital terminals)

Comm Format INT

Size: 3 x Input, 3 x Output

1 x BK9105

2 x KL1002

2 x KL2012

1 x KL9010

Offset	Name	Inputs	Outputs
0	Control/Status Word 0	DeviceName:I.data[0]	DeviceName:O.data[0]
1	Control/Status Word 1	DeviceName:I.data[1]	DeviceName:O.data[1]
2	digital terminals	DeviceName:I.data[2] (Bit 0..3, 4..15 unused)	DeviceName:O.data[2] (Bit 0..3, 4..15 unused)

Example 2:

Comm Format INT

Size: 7 x Input, 7 x Output

1 x BK9105

1 x KL1408

2 x KL2012

1 x KL3312

1 x KL9010

Offset	Name	Inputs	Outputs
0	Control/Status Word 0	DeviceName:I.data[0]	DeviceName:O.data[0]
1	Control/Status Word 1	DeviceName:I.data[1]	DeviceName:O.data[1]
2	KL3312 Channel 0 Control/Status	DeviceName:I.data[2] (Bit 0..7, 8..15 unused)	DeviceName:O.data[2] (Bit 0..7, 8..15 unused)
3	KL3312 Channel 0	DeviceName:I.data[3] (Bit 0..15)	DeviceName:O.data[3] (Bit 0..15)
4	KL3312 Channel 1 Control/Status	DeviceName:I.data[4] (Bit 0..7, 8..15 unused)	DeviceName:O.data[4] (Bit 0..7, 8..15 unused)
5	KL3312 Channel 1	DeviceName:I.data[5] (Bit 0..15)	DeviceName:O.data[5] (Bit 0..15)
6	digital terminals	DeviceName:I.data[6] (Bit 0..7, 8..15 unused)	DeviceName:O.data[6] (Bit 0..3, 4..15 unused)

BK9105 Control and Status

Status Bits 0 to 31

0	1	2*	3*	4	5	6	7	8 to 15*	16 to 23	24 to 31
K1	-	L1	L2	-	-	-	-	K-Bus Counter	K-Bus Error Code	K-Bus Error argument

K1 - if K1 = TRUE, K-Bus error, Error Code bit 16-31 (see K-Bus Error LED |► 50])

L1 or L2 active

* Firmware version B3 increment if a K-Bus cycle is ready

Control Bits 0 to 31

0	1	2*	3*	4	5	6	7	8	9	10	11	12	13	14	15	16 to 23	24 to 31
K1	R1	L1	L2	-	-	-	-	-	-	-	-	-	-	-	-	-	-

K1 - 0->1 rising Trig K-Bus Reset

R1 - 1->0 falling Trig Reboot BK9105

L1 - 1-> Outputs are frozen

L2 - 1-> Leave K-Bus Cycle, if L1 and L2 TRUE then is only L2 active

*) Firmware version B3 necessary

4.5.2 EthernetIP Tag Wizard

i Mapping

The BK9105 can be mapped as short integer (byte), integer (word), or double integer (double word). In the following description it is mapped as double integer!

Installation

-  Download the file *EIPTOOL.zip* from this CHM-File click on the following Link (https://infosys.beckhoff.com/content/1033/bk9055_bk9105/Resources/zip/4524990475.zip)
- Extract all the contained files from the ZIP file into a folder (e.g. BK9105helper) on your PC
- Start the EtherNetIPConfigTool.exe

Overview

This application note covers how to use the EthernetIP Tag Wizard. After reading this note you will be able to build a rack of Beckhoff IO and automatically import it into RSLogix 5000. Not only will the nodes be automatically created, but the IO will have an exact description in the IO map.

Supporting Documents and References

Put link to BK9105 here, as well as the link to the EIP tool.

Key Concepts

With this tool a user will be able to create the Beckhoff IO Rack, save the IO mapping configuration and Import that configuration into RSLogix 5000. RSLogix 5000 does not need to be installed on the PC you have the Tag Wizard on, however it will be convenient.

Procedure

To get started we have to have an RSLogix configuration with a minimum of a processor and Ethernet IP Master. If you are simply adding a rack to an existing configuration, this process will be the same.

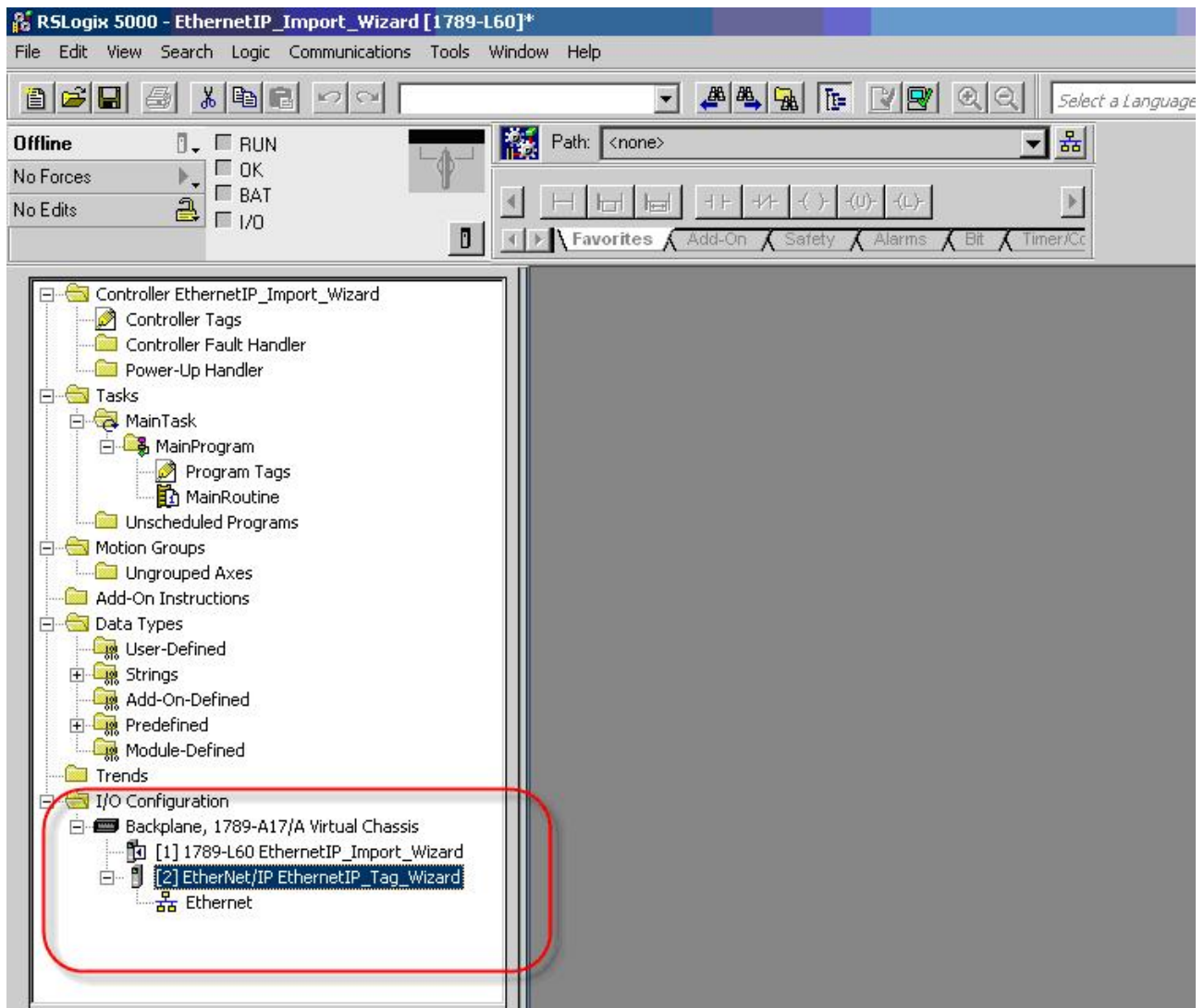

Fig. 15: EthernetIP Tag Wizard

All one has to do is simply save this configuration as an .L5K file to the desired location. In this example, all files are saved to the root directory of the Tag Wizard.

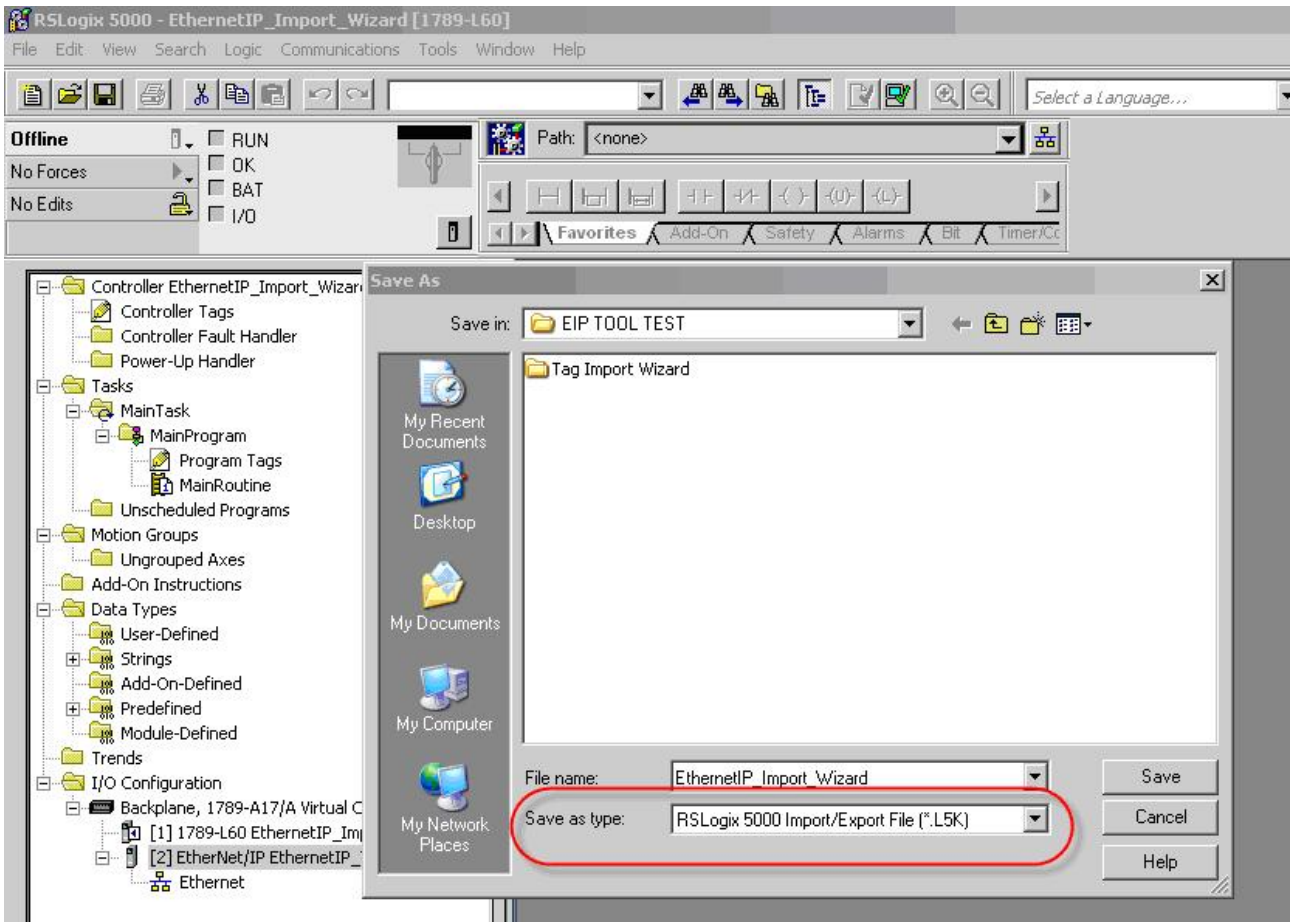

Fig. 16: EthernetIP Tag Wizard - Save as type

Once the RSLogix 5000 configuration is saved please minimize and open up the folder where the tag wizard is stored. In this folder you will find a couple reference files. The EthernetIPMaster.txt is very important. This is a text file that stores the name that Rockwell gives its scanners. If your scanner is NOT in the list, please feel free to add it. It is VERY important that the scanner is added just as it appears in your .L5K file.

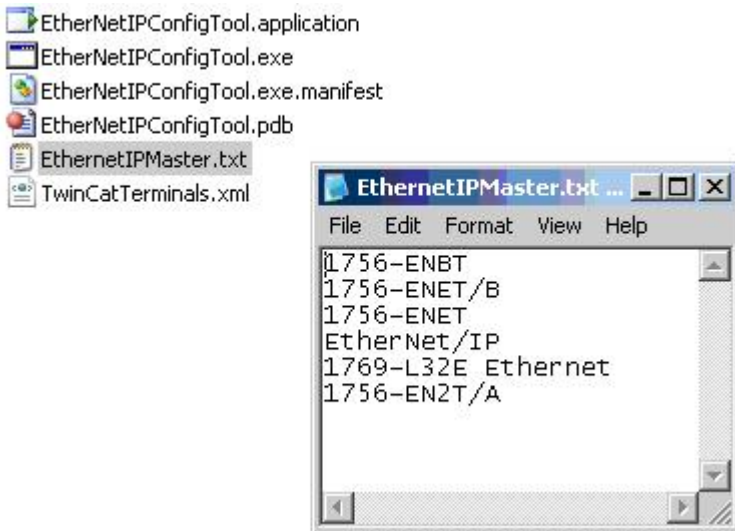

Fig. 17: EthernetIP Tag Wizard - EthernetIPMaster.txt

At this point all one has to do is double click on EtherNetIPConfigTool.exe and it will open. Once open, add your BK9105 or IL230x-B905 to the configuration.

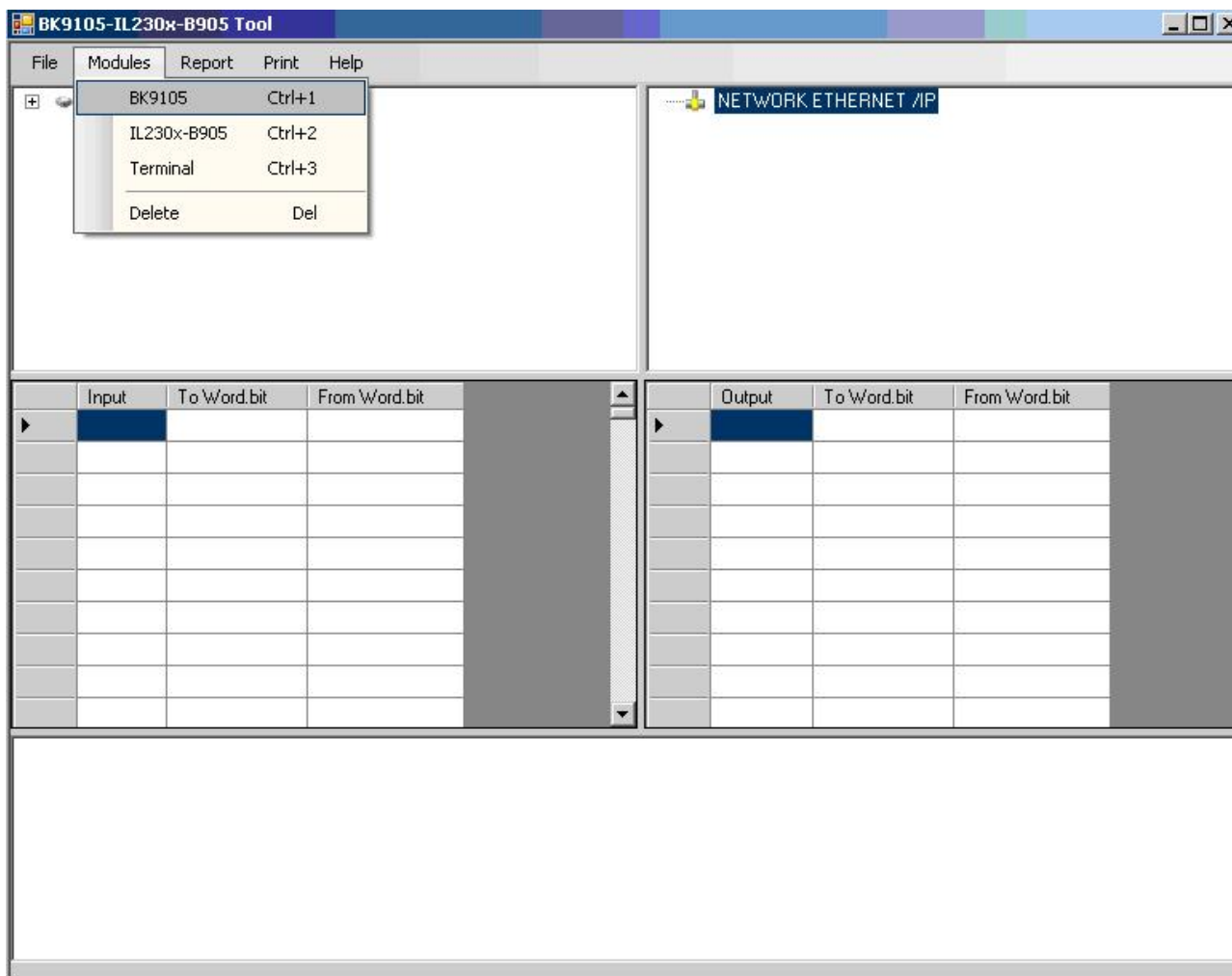

Fig. 18: EthernetIP Tag Wizard - EtherNetIPConfigTool

When adding your coupler you will be prompted to enter the correct IP address.



Fig. 19: EthernetIP Tag Wizard - Enter IP address

If you select the Field Bus Box IL230X-B905 you will be prompted additionally with the following.

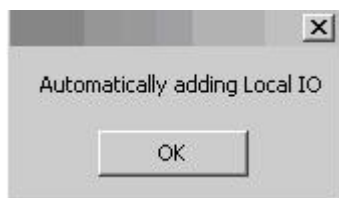

Fig. 20: EthernetIP Tag Wizard - Automatic adding Local IO

The software automatically is adding the 230x combo box to your configuration.

At this point you simply add the IO to your configuration in the order that they are left to right on the coupler, by simply double clicking on the correct terminal.

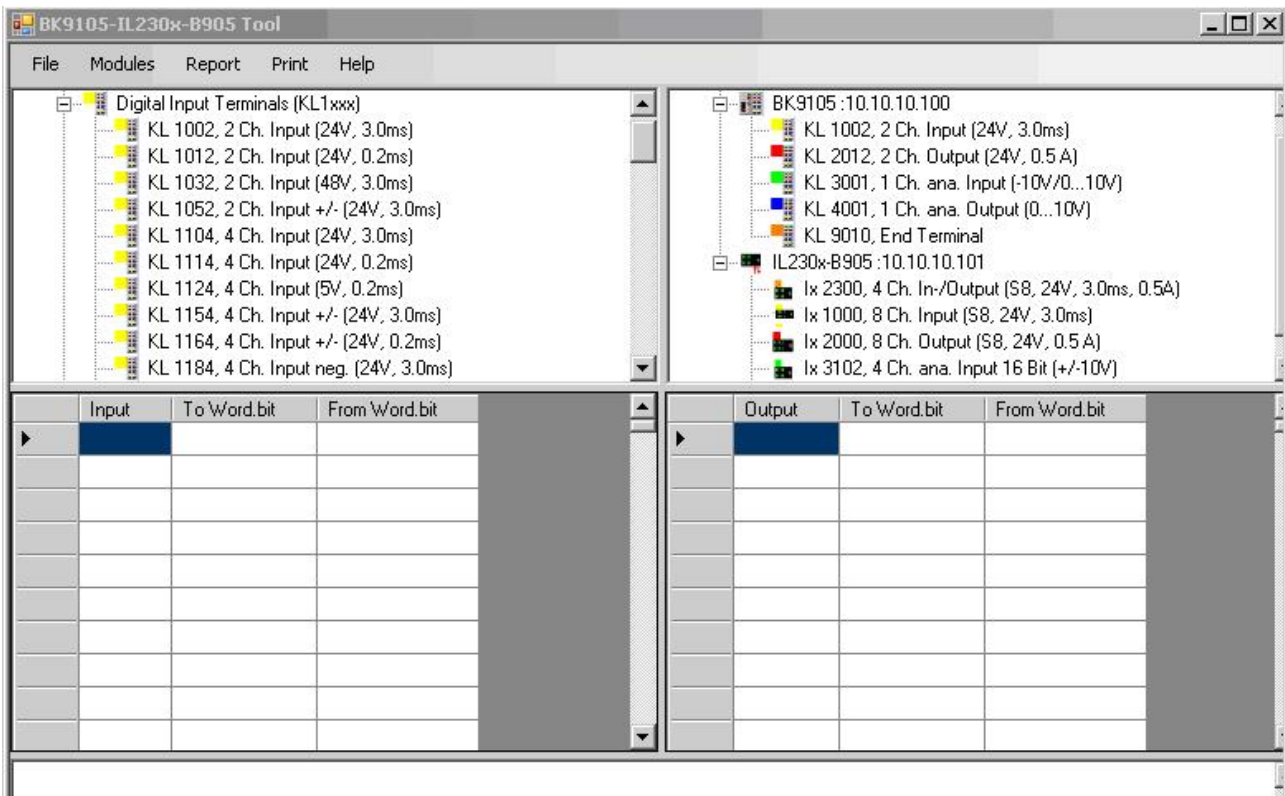

Fig. 21: EthernetIP Tag Wizard - Adding the IO to cour configuration

Once you have all the IO added in the correct order, you have a couple different selections as to how to save review or export this data. To review, all one has to do is simply select the coupler you want to review and then Report>Coupler (Or network [If network is selected only the first coupler will show graphically but the mapping below is correct])

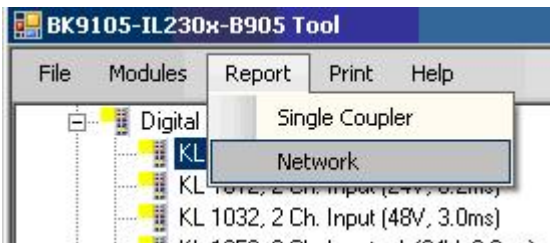

Fig. 22: EthernetIP Tag Wizard - selections

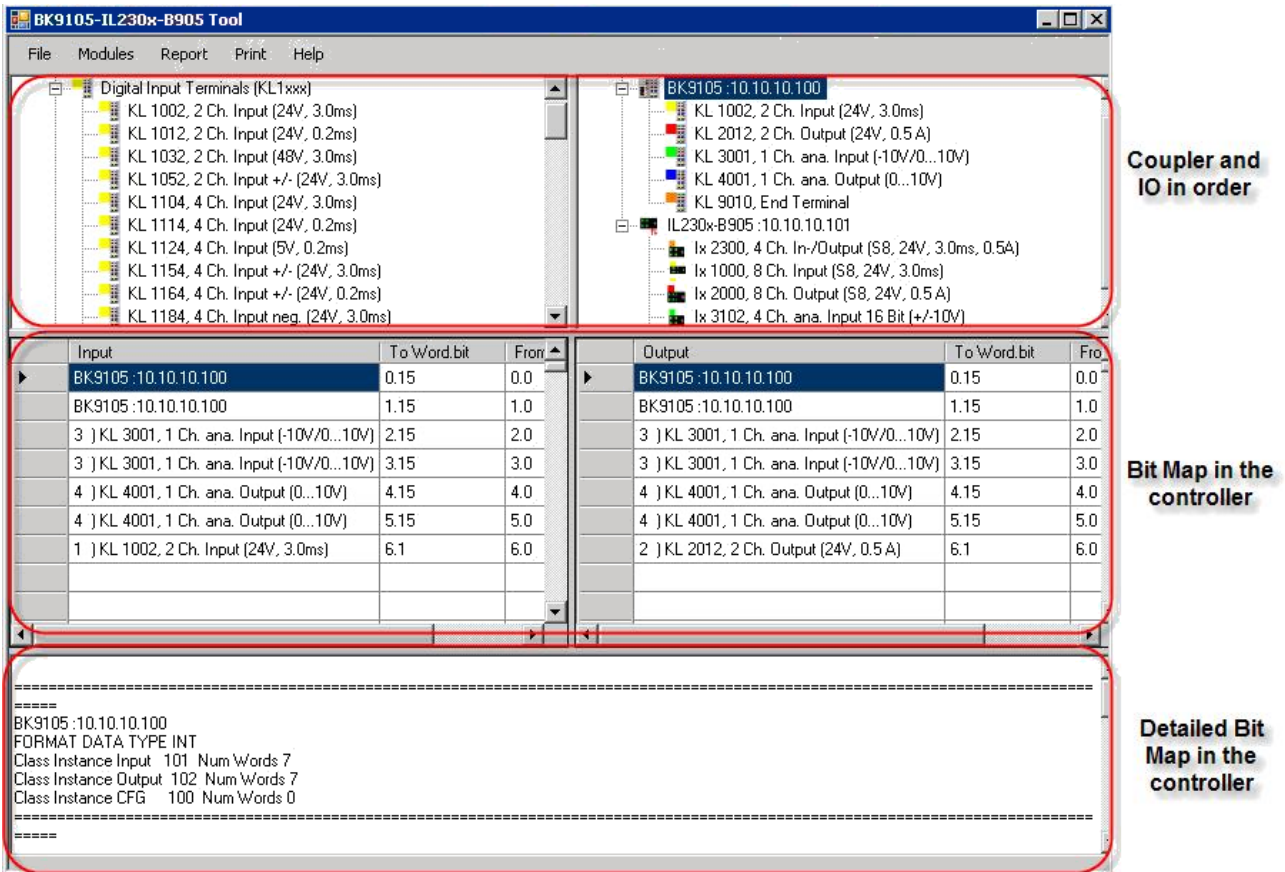

Fig. 23: EthernetIP Tag Wizard - Mapping

All one has to do at this point to save or export the data is File>Save XML (this saves the configuration to a XML file, File>Save Network Report (saves so as you can print it for machine documentation) Save>Configuration (If you want to add to this configuration in the future) and File>Save To L5K file.

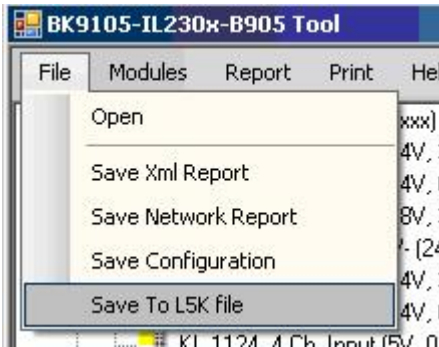

Fig. 24: EthernetIP Tag Wizard - Save To L5K file

When saving to a L5K file you are prompted to select the correct Ethernet IP master (This list is read from the text file mentioned earlier).

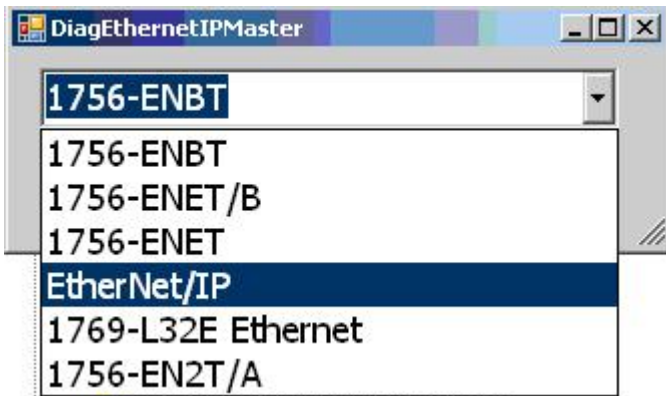

Fig. 25: EthernetIP Tag Wizard - choose the correct Ethernet IP master



Fig. 26: EthernetIP Tag Wizard select the correct Ethernet IP master

Once we have the master selected, then choose OK.

Next you will be prompted to select the correct path to the stored .L5K file, and select Open. Once opened you will notice an AB.L5K file in the same directory you saved the original L5K file.

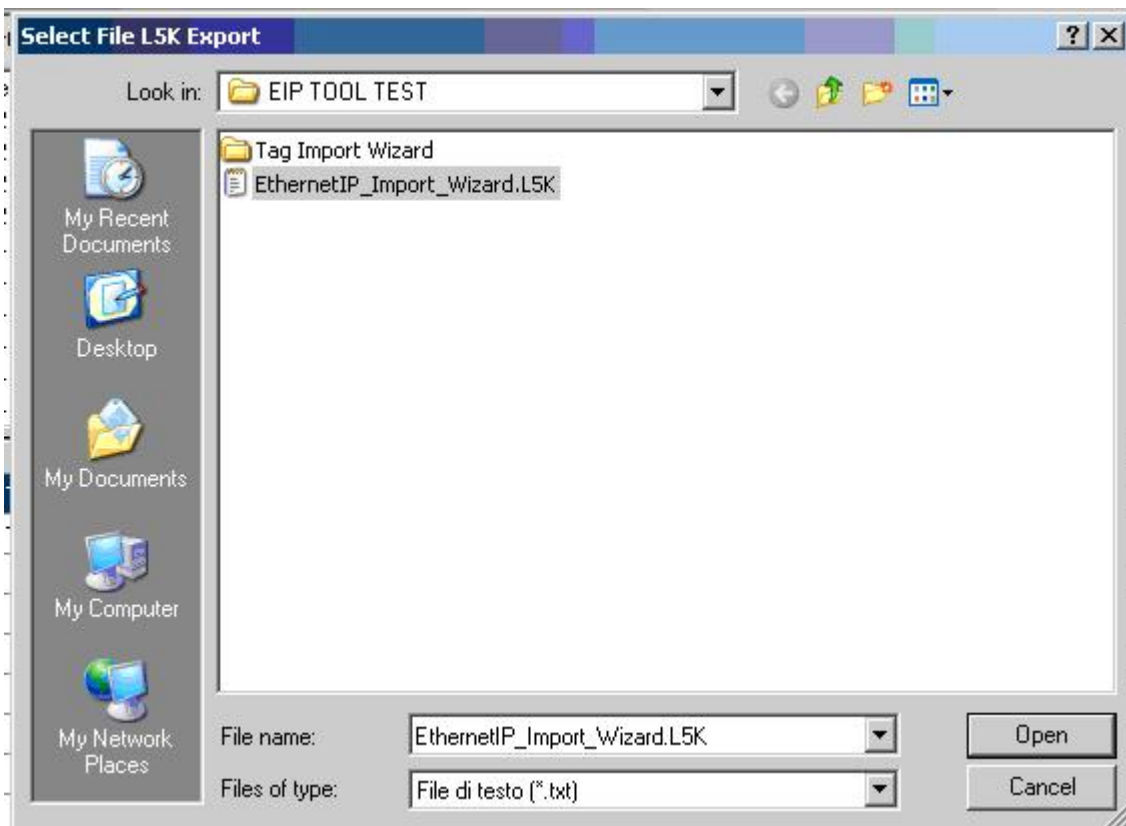

Fig. 27: EthernetIP Tag Wizard - select the correct path to the stored .L5K file

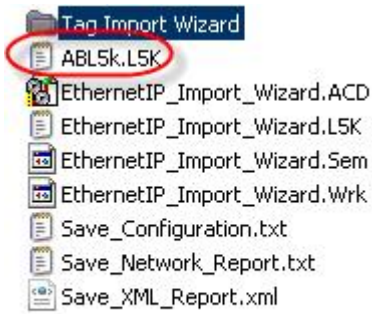

Fig. 28: EthernetIP Tag Wizard - ABL5k.L5K

Go back to RSLogix 5000, File>Open>

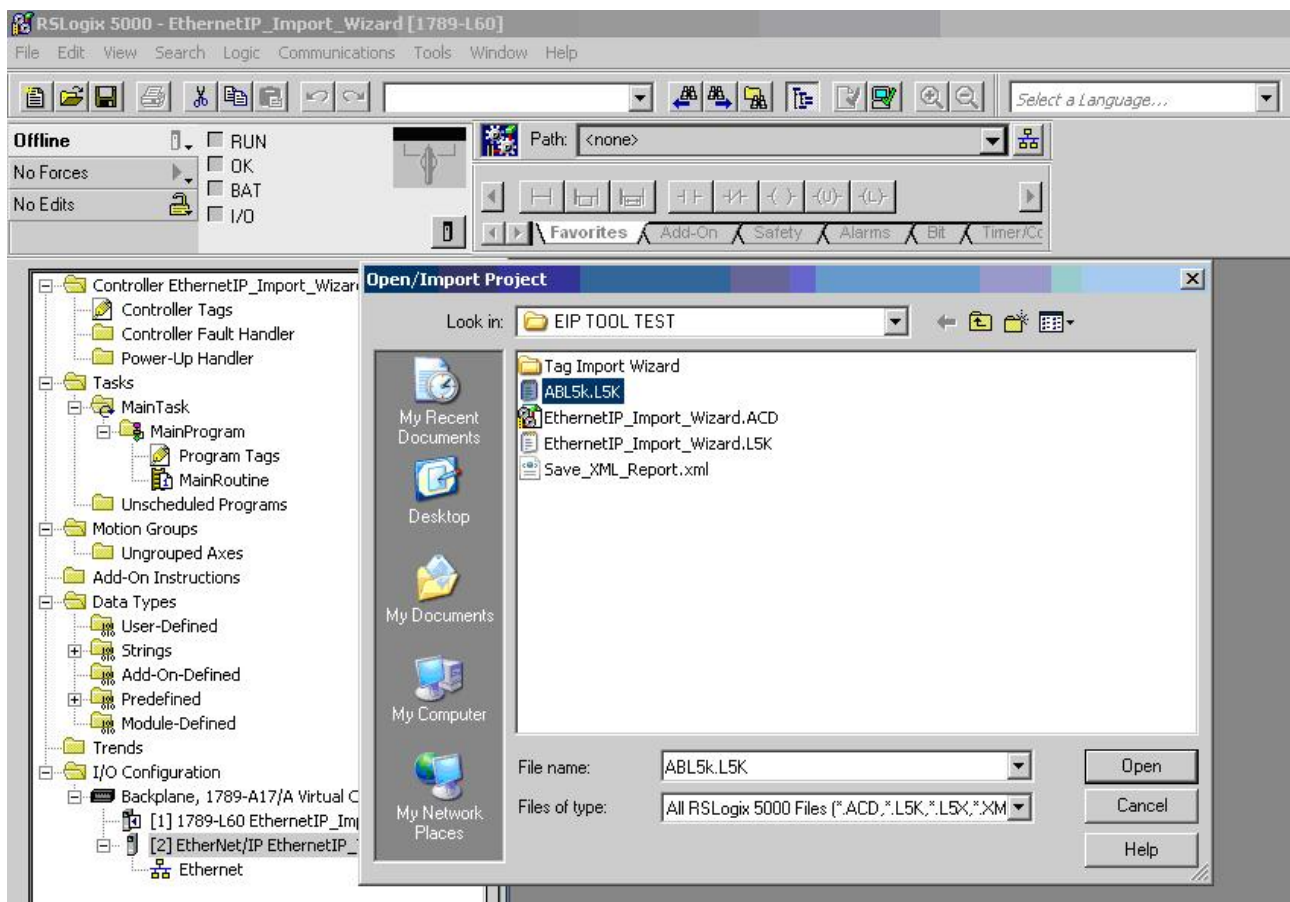

Fig. 29: EthernetIP Tag Wizard - open the L5K file

Select the NEW .L5K file then Import

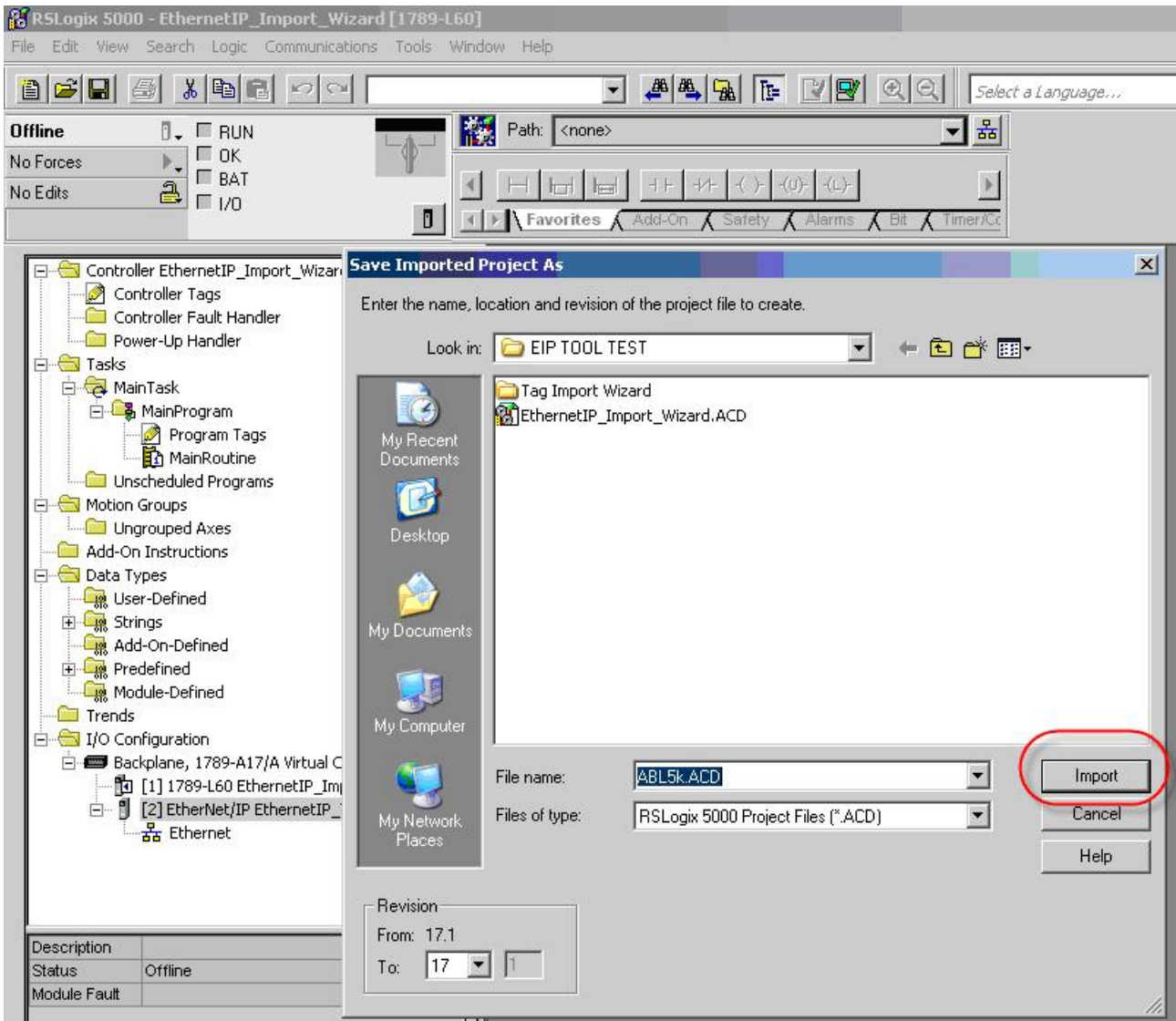

Fig. 30: EthernetIP Tag Wizard - Save the Imported Project

Now to check out all of the new IO

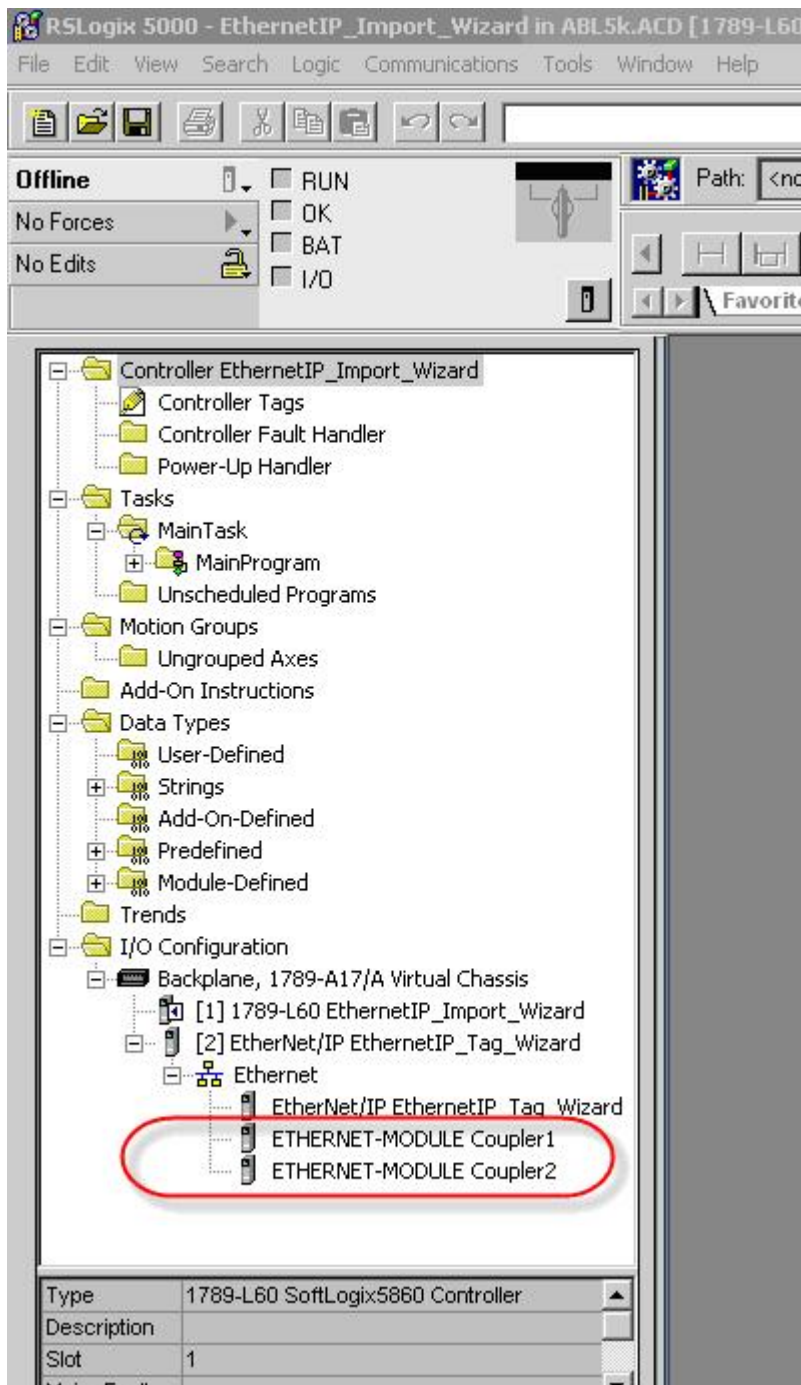

Fig. 31: EthernetIP Tag Wizard - check out all of the new IO

Please note to look in the Controller tags for not only did the software create new module defined tags, it labeled them accordingly in the Logical order, NOT the physical order.

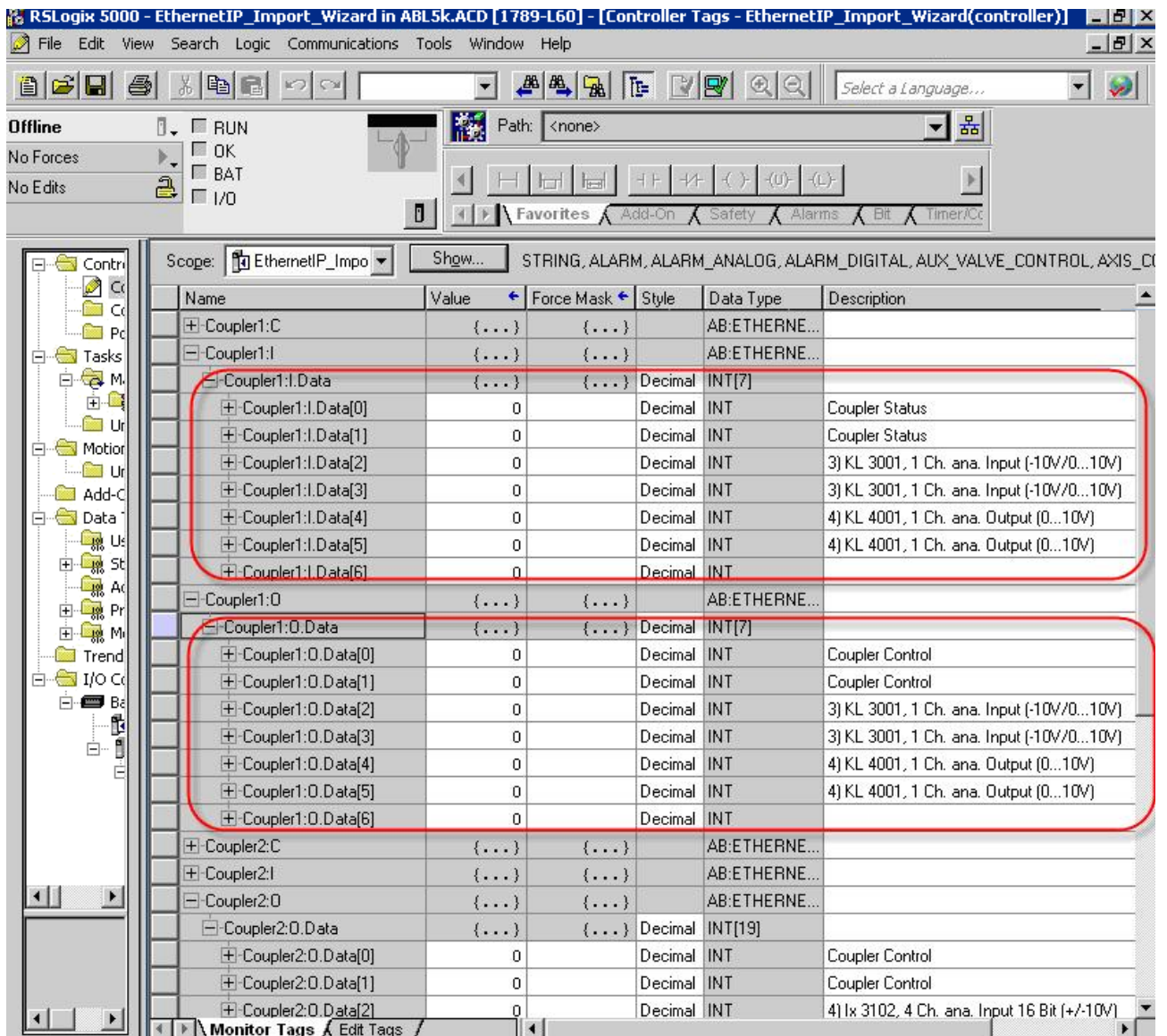

Fig. 32: EthernetIP Tag Wizard - Controller tags

i Coupler Status and Coupler Control

After the import is successful, please see that the Coupler Status and Coupler Control is described at the bit level. Also the status and control for each complex channel is defined with the HBYTE->Empty LBYTE Status or Ctrl as the upper byte is padded.

4.5.3 Export to Rockwell

Create a master Ethernet IP (limitation only master, not Multimaster support)

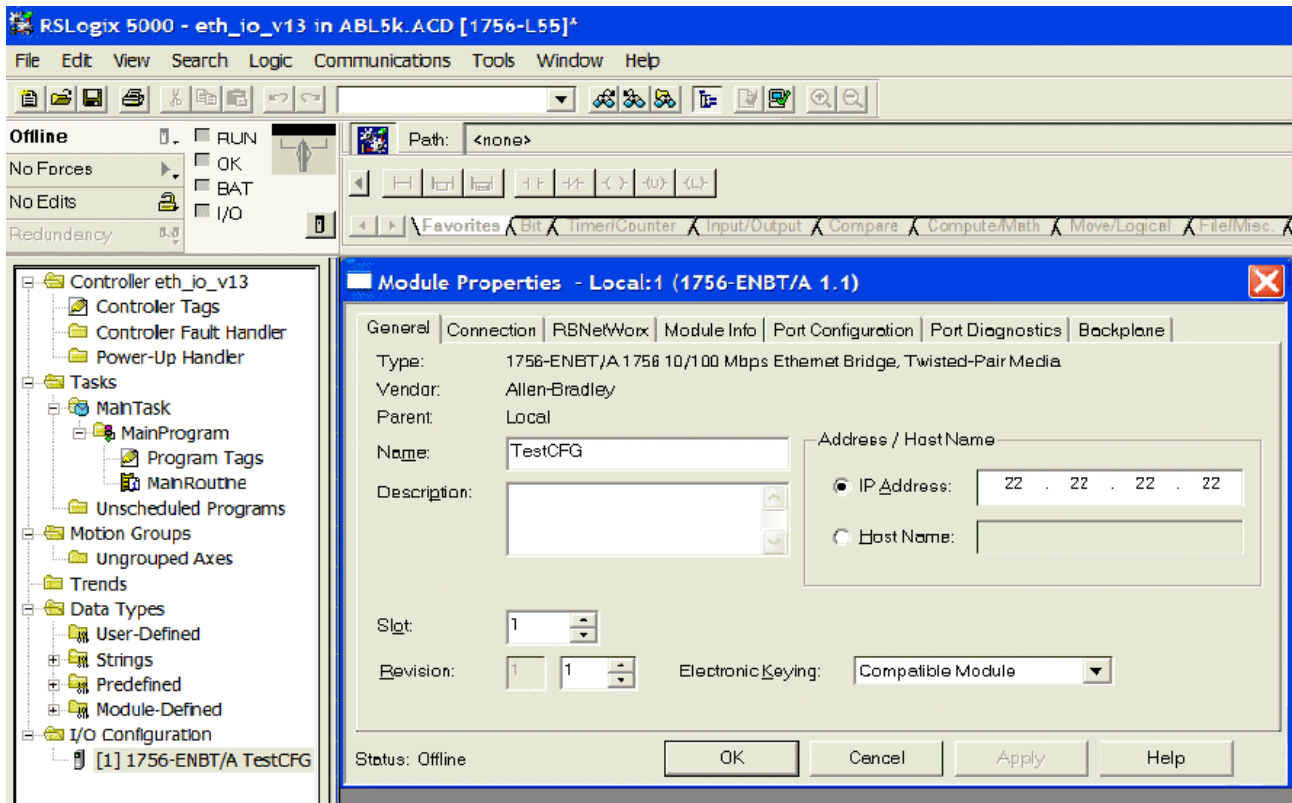

Fig. 33: Export to Rockwell - Create a master Ethernet IP

Save as the project as .L5k format

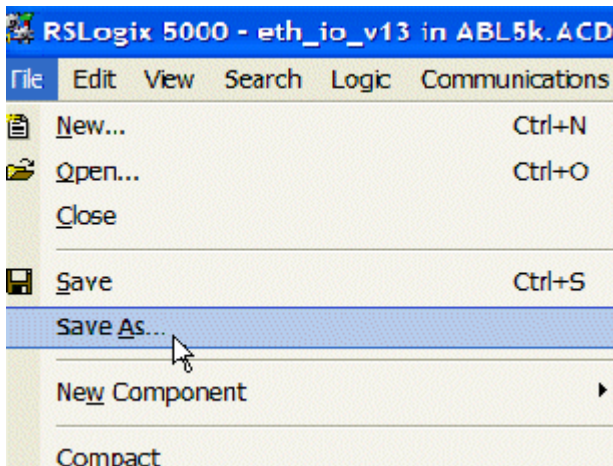

Fig. 34: Export to Rockwell - Save as the project as .L5k format, step 1

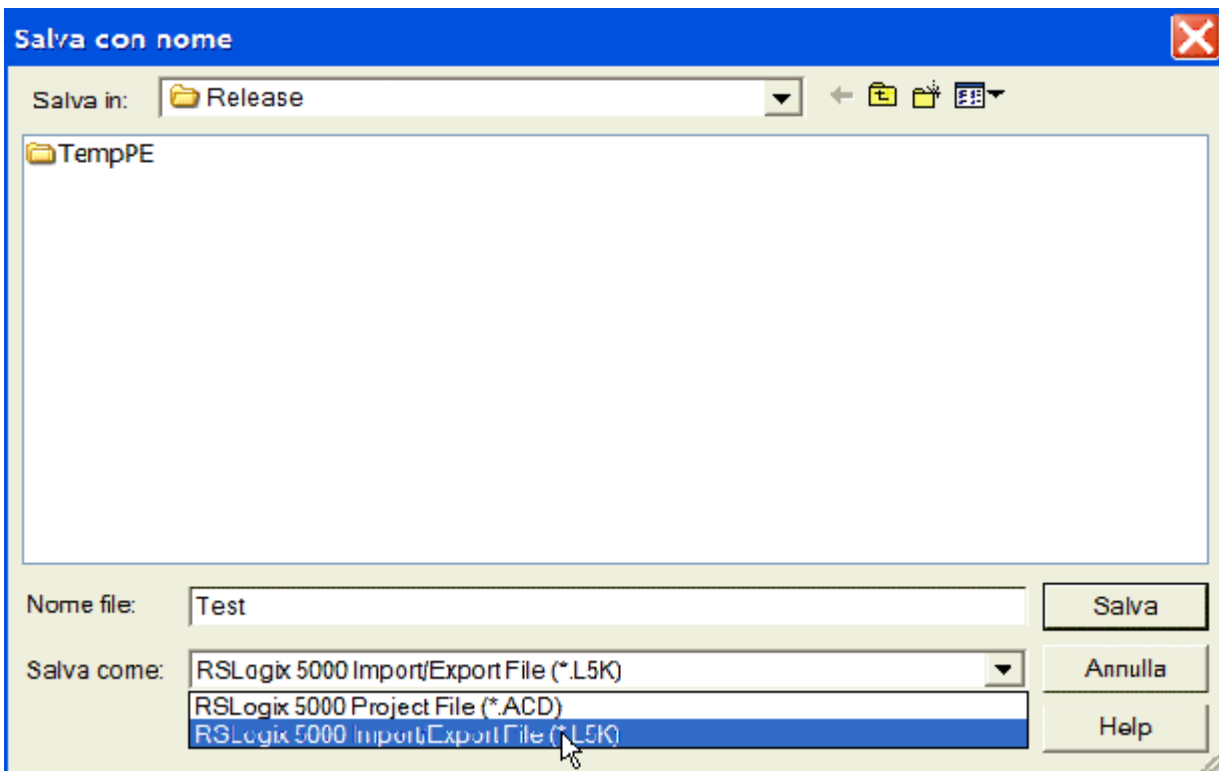

Fig. 35: Export to Rockwell - Save as the project as .L5k format, step 2

Create the project with the configurator and export with the push button AB CSV

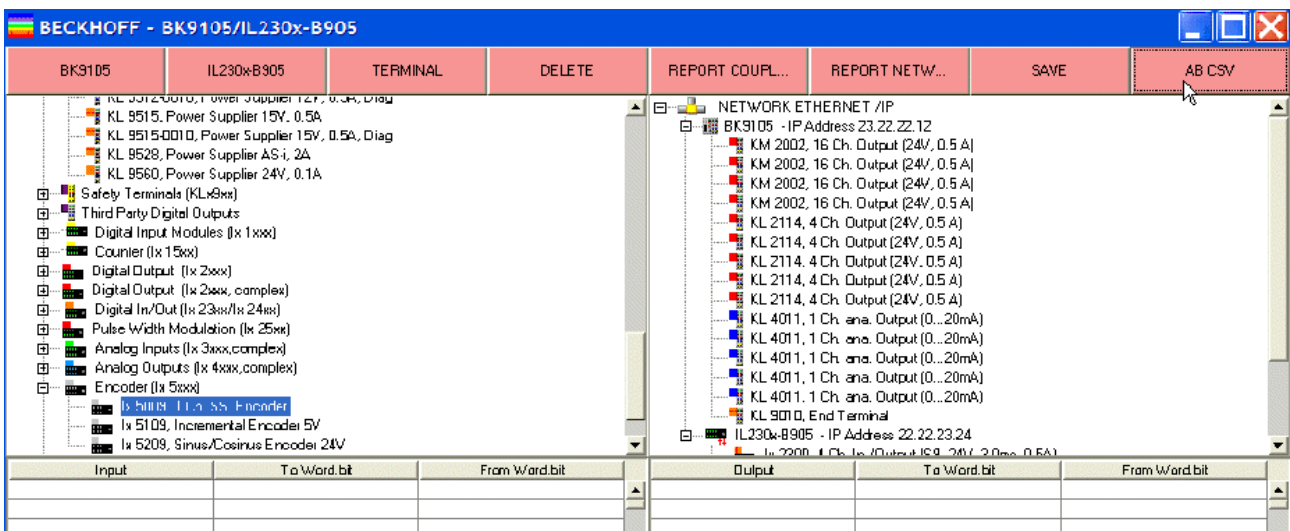

Fig. 36: Export to Rockwell - export with the push button AB CSV

Select the file L5k, which you have generated

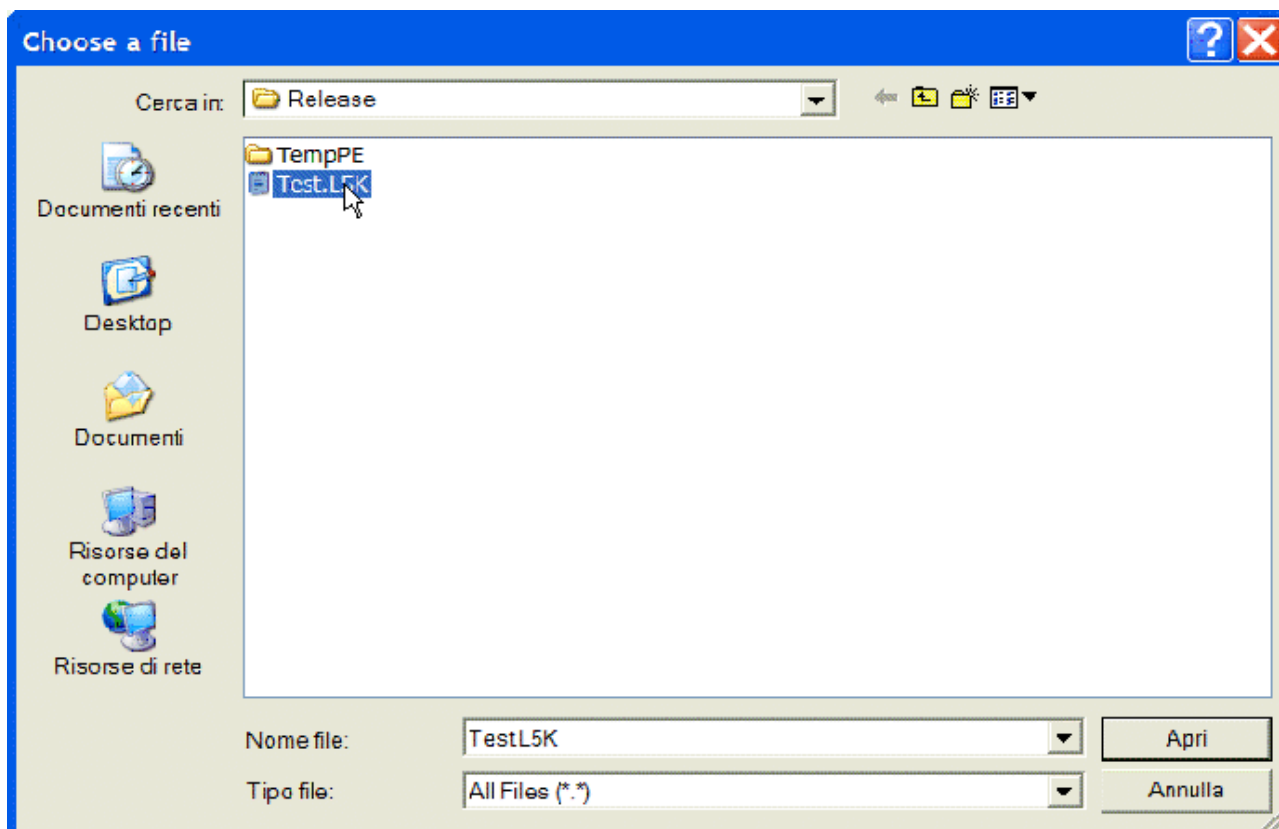

Fig. 37: Export to Rockwell - Select the created file L5k

Open AB's tool, and select open

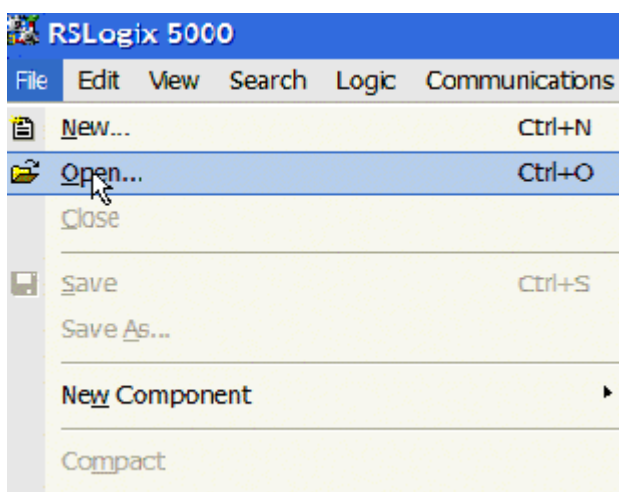

Fig. 38: Export to Rockwell - open the ABL5K.L5K

Select the file ABL5K.L5K (fixed name!)

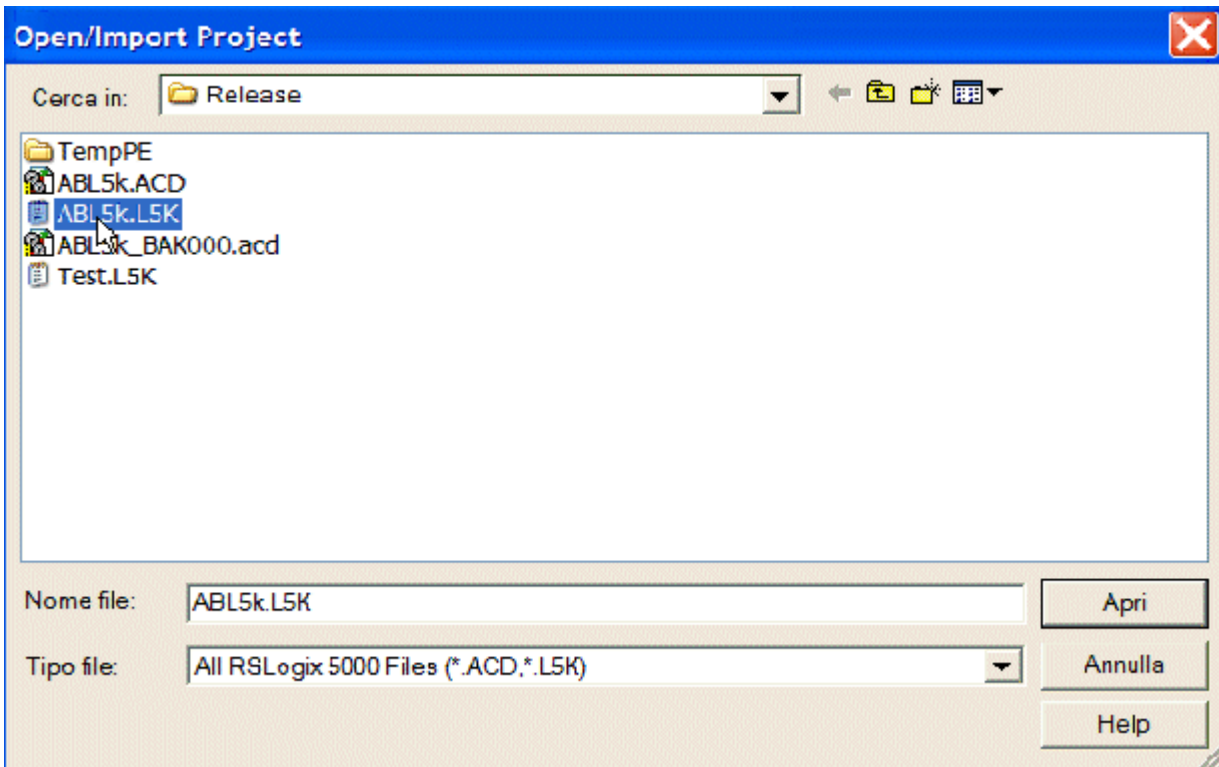

Fig. 39: Export to Rockwell - Select the file ABL5K.L5K

Save the project as ACD

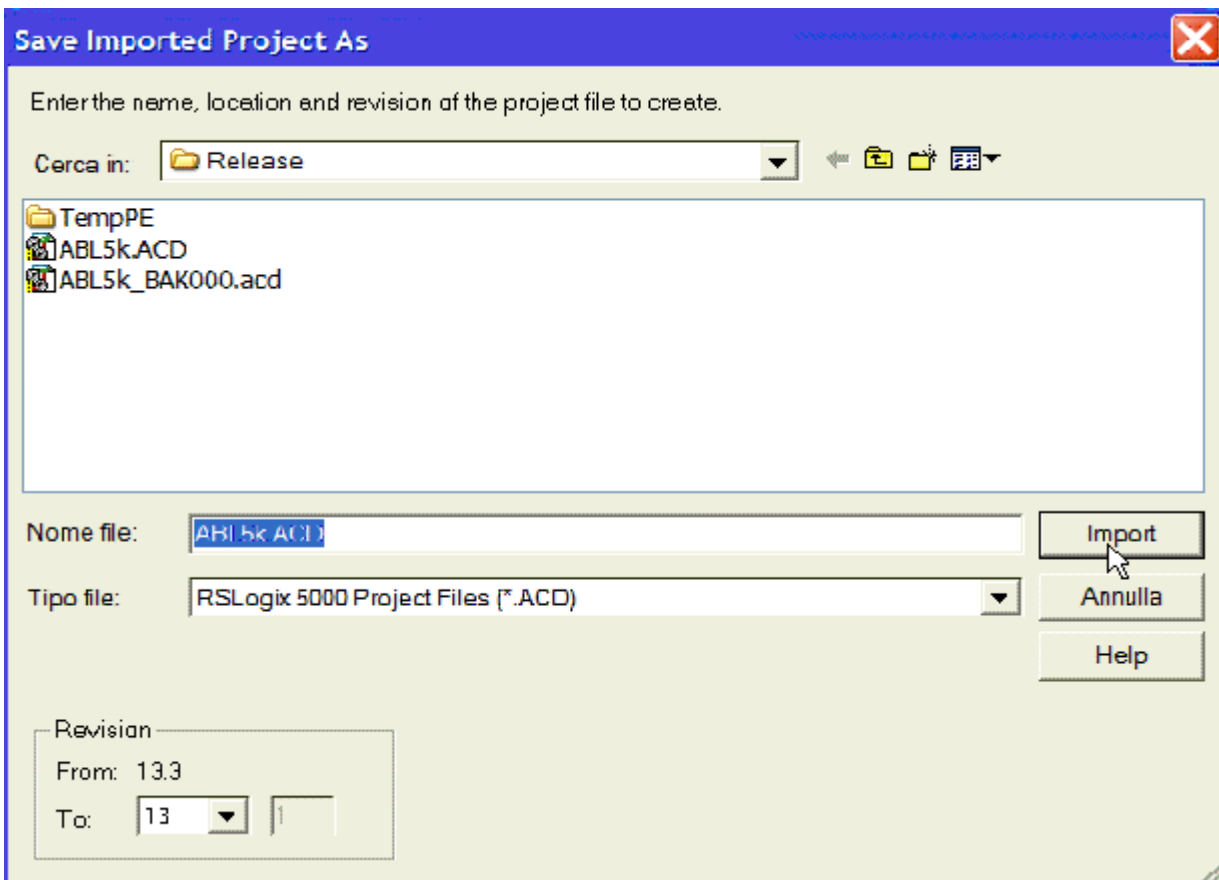

Fig. 40: Export to Rockwell - Save the project as ACD

Read the import configuration, with the comments

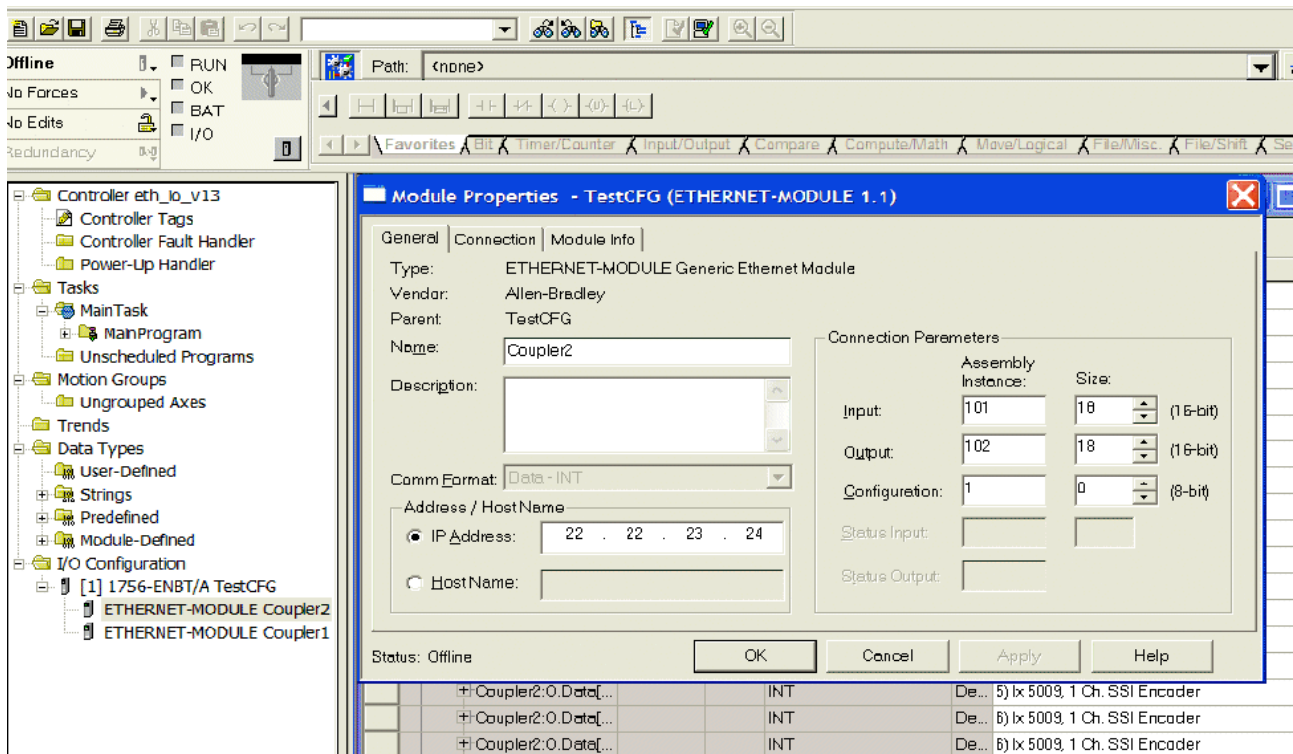

Fig. 41: Export to Rockwell - Read the import configuration

5 Error handling and diagnosis

5.1 Diagnostic LEDs

After switching on, the Bus Coupler immediately checks the connected configuration. Error-free start-up is indicated when the red *I/O ERR* LED goes out. If the *I/O ERR* LED blinks, an error in the area of the terminals is indicated. The error code can be determined from the frequency and number of blinks. This permits rapid rectification of the error.

The Bus Coupler has two groups of LEDs for the display of status. The upper group with four LEDs indicates the status of the respective fieldbus. The significance of the fieldbus status LEDs is explained in the appropriate sections of this manual. It corresponds to the usual fieldbus display.

On the upper right hand side of the Bus Couplers are two more green LEDs that indicate the supply voltage. The left hand LED indicates the presence of the 24 V supply for the Bus Coupler. The right hand LED indicates the presence of the supply to the power contacts.

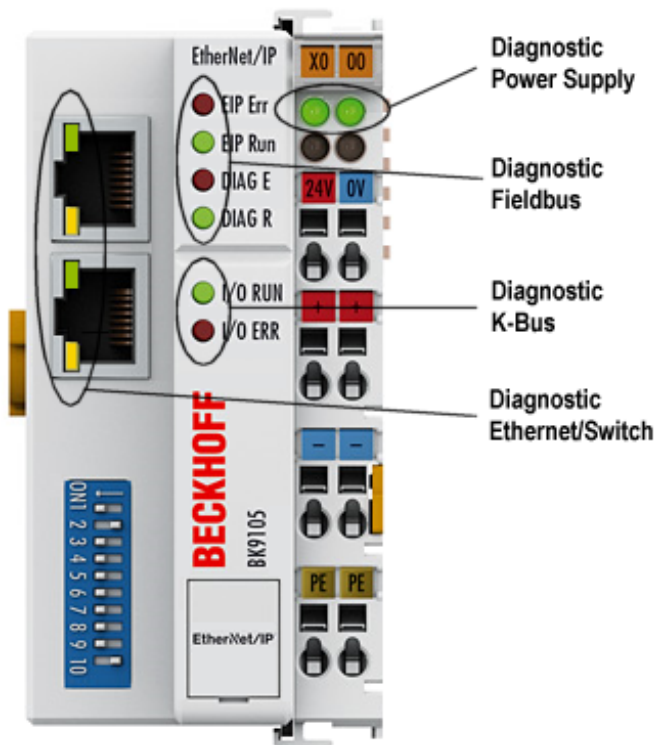

Fig. 43: BK9105 Diagnostic LEDs

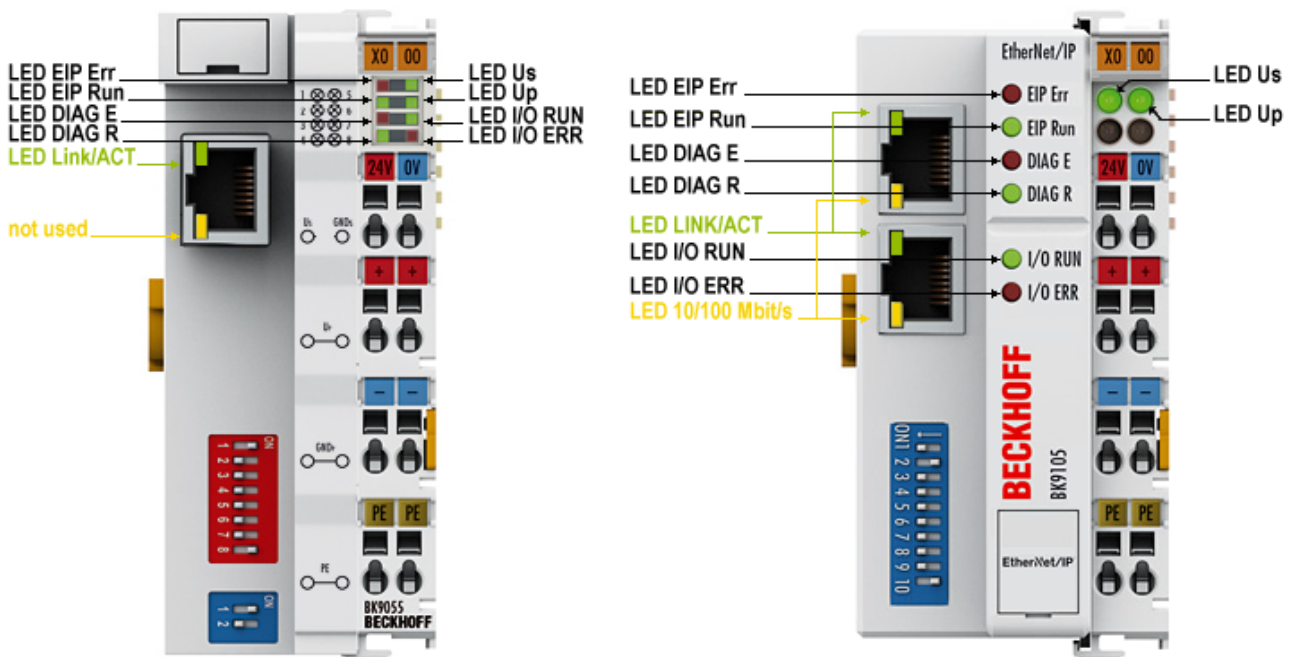

Fig. 44: BK9055, BK9105 - LEDs

LEDs for power supply diagnosis

LED	Meaning	
LED Us	off	The power supply voltage Us is not present
	on	The power supply voltage Us is present
LED Up	off	The power supply voltage Up (for Power Contacts) is not present
	on	The power supply voltage Up (for Power Contacts) is present

LEDs at RJ45

LED	Meaning	
LED Link/Act	off	No physical connection present
	on	Physical connection present
	flashes	Communication available
LED 10/100 Mbit/s (BK9105 only)	off	10 Mbit/s (if LED Link/Act is shining or flashing)
	on	100 Mbit/s

LEDs for fieldbus diagnosis

EtherNet/IP Diagnosis	EIP E (red)	EIP R (green)	DIAG E (red)	DIAG R (green)
IP Address OK	off	0,5s	x	x
No IP Address (Dip Switch 8,9 -> on)	off	off	x	x
Online	off	on	x	x
Offline PLC Stop	off	0,1s	x	x
TimeOut	0,5s	off	x	x
IP Address conflict	on	off	x	x

Configuration Diagnosis	EIP E (red)	EIP R (green)	DIAG E (red)	DIAG R (green)
OK	x	x	off	on
In data too less	x	x	Flashing*	1
In data too big	x	x	Flashing*	2
Out data too less	x	x	Flashing*	3
Out data too big	x	x	Flashing*	4
Wrong Assembly Instance	x	x	Flashing*	5
Second Master	x	x	Flashing*	6

*) Bytes are too less (missing) or to big

X: The status of the LED is not relevant for this diagnosis.

Example:

Data Length In too big 5 Bytes...

- Start Error Code: Red LED is quickly flashing, green LED is Off
- Red LED is ON, green LED show you the Error Code flashing 2 times (1 Sec)
- Red LED OFF, green LED off
- Red LED flashing 5 times (1 Sec), error argument, green LED off

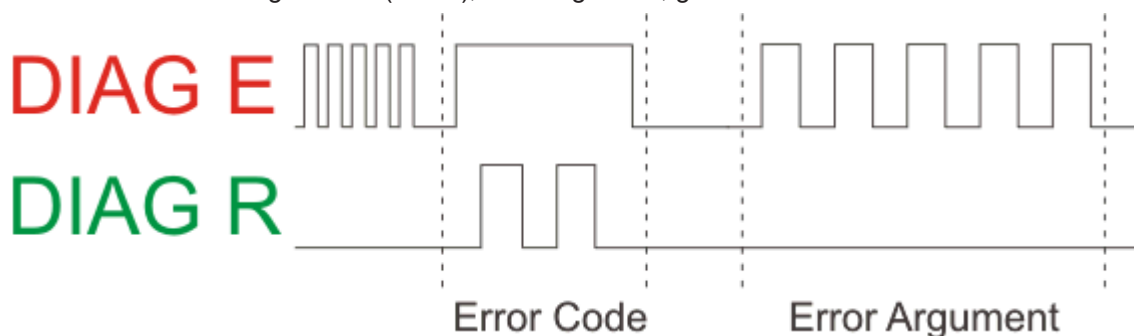

Fig. 45: Example for Error Code and Error Argument

LEDs for K-Bus diagnosis

Error code	Error Argument	Description	Remedy
Persistent, continuous blinking		EMC problems	<ul style="list-style-type: none"> • Check power supply for overvoltage or undervoltage peaks • Implement EMC measures • If a K-Bus error is present, it can be localized by a restart of the coupler (by switching it off and then on again)
1 pulse	0	EEPROM checksum error	Set manufacturer's setting with the KS2000 configuration software
	1	Code buffer overflow	Insert fewer Bus Terminals. The programmed configuration has too many entries in the table
	2	Unknown data type	Software update required for the Bus Coupler
2 pulses	0	Programmed configuration has an incorrect table entry	Check programmed configuration for correctness
	n (n > 0)	Table comparison (Bus Terminal n)	Incorrect table entry
3 pulses	0	K-Bus command error	<ul style="list-style-type: none"> • No Bus Terminal inserted • One of the Bus Terminals is defective; halve the number of Bus Terminals attached and check whether the error is still present with the remaining Bus Terminals. Repeat until the defective Bus Terminal is located.
4 pulses	0	K-Bus data error, break behind the Bus Coupler	Check whether the n+1 Bus Terminal is correctly connected; replace if necessary.
	n	Break behind Bus Terminal n	Check whether the Bus End Terminal KL9010 is connected.
5 pulses	n	K-Bus error in register communication with Bus Terminal n	Exchange the nth bus terminal
6 pulses	0	Error at initialization	Exchange Bus Coupler
	1	Internal data error	Perform a hardware reset on the Bus Coupler (switch off and on again)
	2	DIP switch changed after a software reset	Perform a hardware reset on the Bus Coupler (switch off and on again)
	4	DIP switch incorrect for BootP	Set 1-8 to <i>on</i> or <i>off</i> , see BootP [► 25]
	8	Internal data error	Perform a hardware reset on the Bus Coupler (switch off and on again)
	16	Error in IP socket	Perform a hardware reset on the Bus Coupler (switch off and on again)
14 pulses	n	nth Bus Terminal has the wrong format	Start the Bus Coupler again, and if the error occurs again then exchange the Bus Terminal
15 pulses	n	Number of Bus Terminals is no longer correct	Start the Bus Coupler again. If the error occurs again, restore the manufacturers setting using the KS2000 configuration software
16 pulses	n	Length of the K-Bus data is no longer correct	Start the Bus Coupler again. If the error occurs again, restore the manufacturers setting using the KS2000 configuration software

6 Appendix

6.1 First Steps

i Mapping

The BK9105 can be mapped as short integer (byte), integer (word), or double integer (double word). In the following description it is mapped as double integer!

Addressing with the BOOTP/DHCP Server 2.3

Switch the DIP Switch 1 to 8 OFF and DIP 9 to 10 ON.

The MAC Address begins with 00-01-05-xx-xx-xx (see under the BK9105, here you find the MAC address).

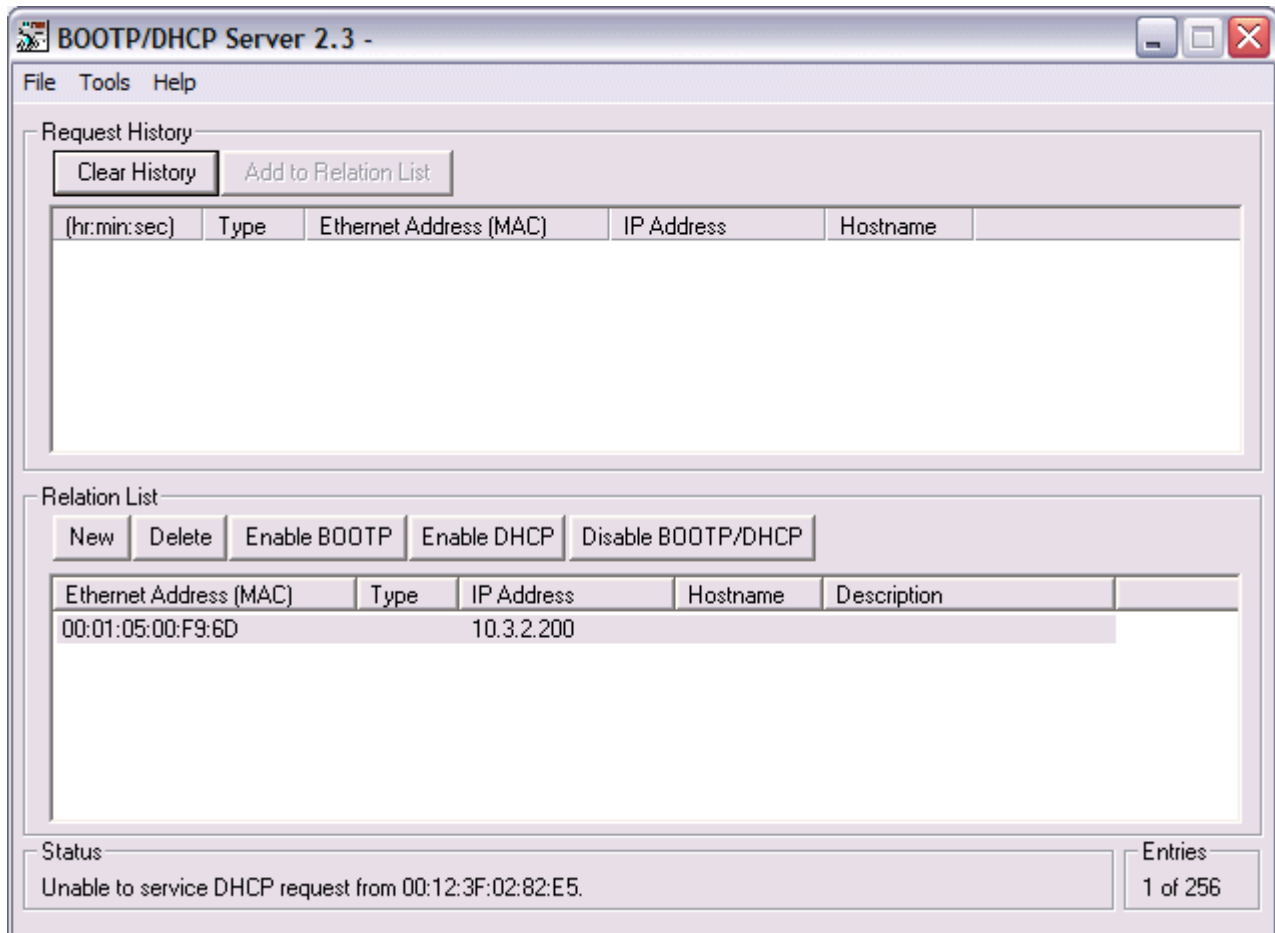

Fig. 46: First Steps - Addressing - Step 1

After a successful addressing you can disable the BOOTP addressing.

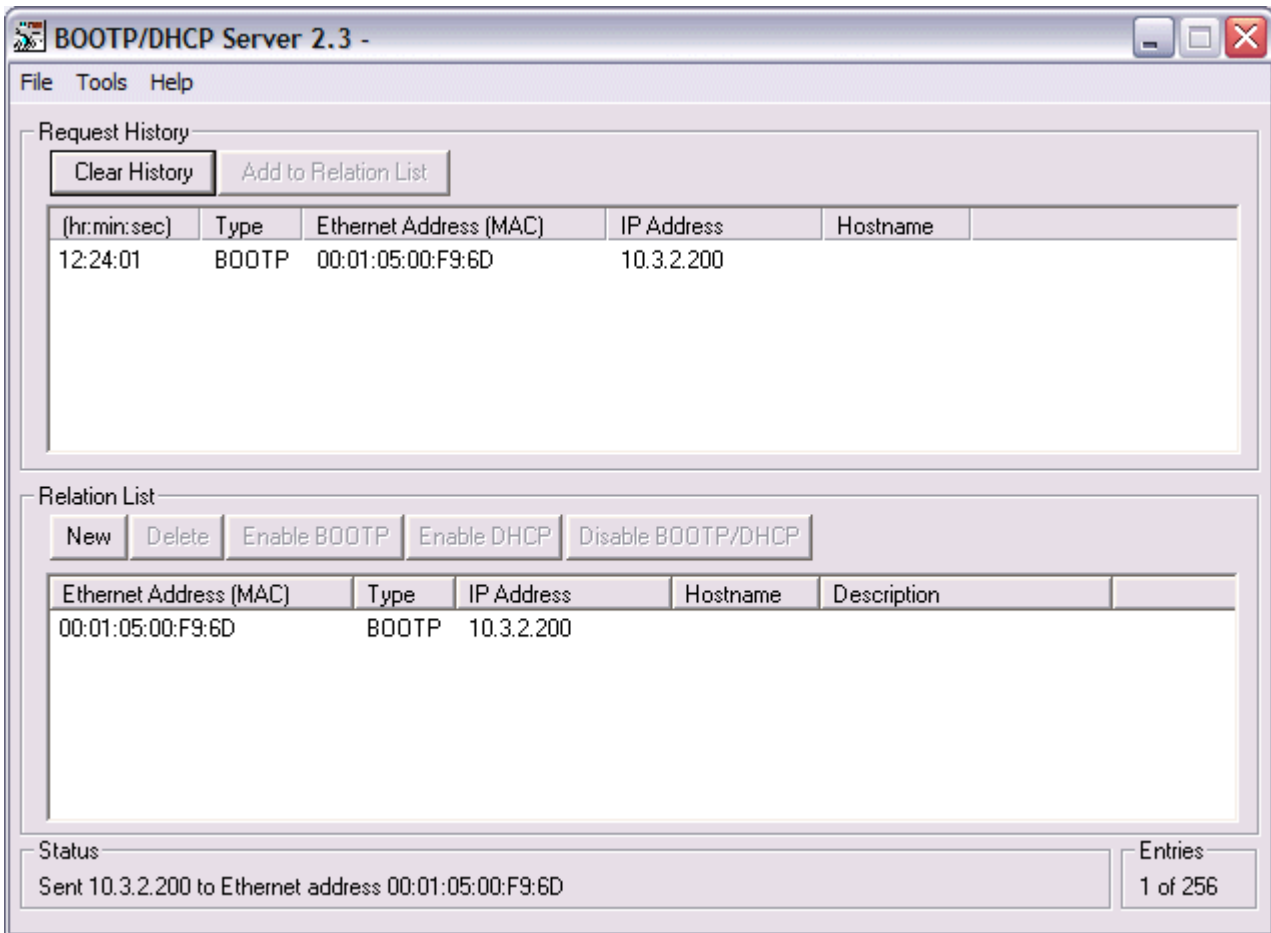

Fig. 47: First Steps - Addressing - Step 2

Open RSLogix 5000 and create a new PLC project

When creating a new project make sure to select the correct controller type and controller settings. In this example we are using a SoftLogix Virtual Chassis, with the BK9105 (Beckhoff EthernetIP Bus coupler)

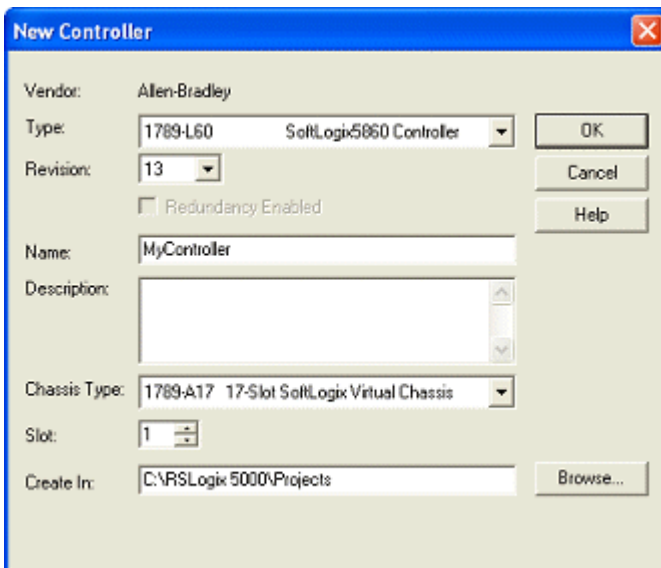

Fig. 48: First Steps - Create a new PLC project

Add Ethernet IP Module

Now you need to add your main communications module. Make sure you know the IP address of the card that is setup as the EtherNet IP card, that address will have to be set in the module settings along with the slot the card is in.

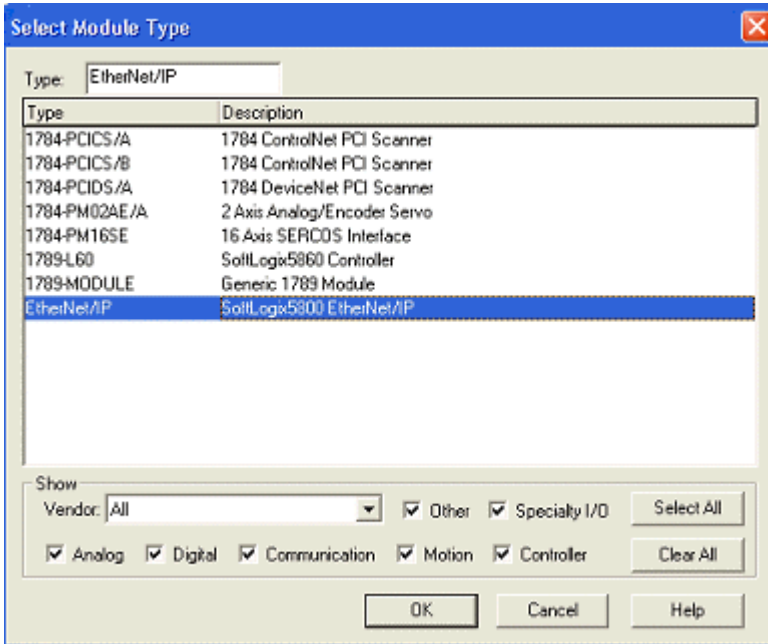

Fig. 49: First Steps - Add Ethernet IP Module

Add Ethernet IP Box

When adding the BK9105 box you must select the "ETHERNET-MODULE" as it is a generic Ethernet/IP device and we will configure it to work with our BK9105.

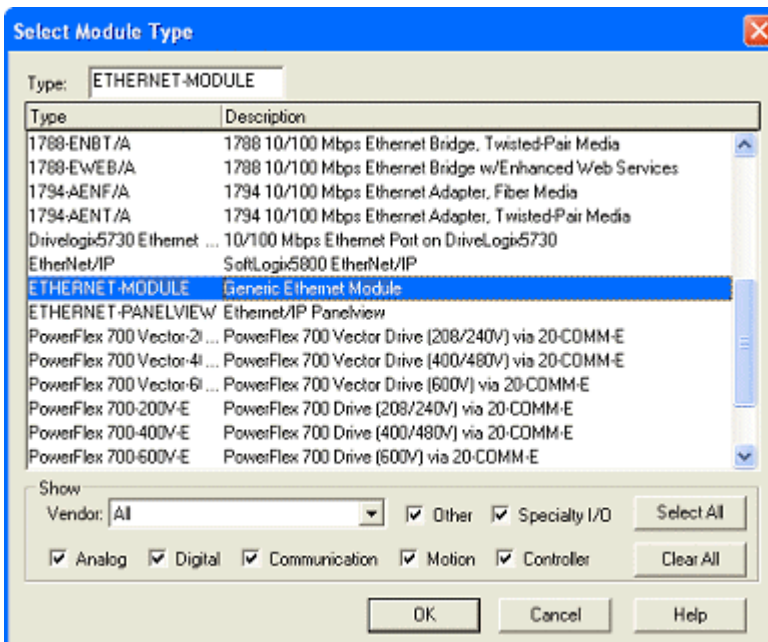

Fig. 50: First Steps - Add Ethernet IP Box

Configuring the BK9105 in RSLogix

For the example here we used two KL1012 terminals and two KL2032. With these cards that gave us 2 words total of input and output data. On the properties dialog you will need to change some of the box settings, please read below for recommendations on settings.

- IP Address (Refer to IP Address section of documentation)
- The Assembly Instances will be as follows
 - Input: 101
 - Output: 102
 - Configuration: 100
- Things to keep in mind when entering the data size for I/O
 - There will always be 4 bytes of input and 4 bytes of output data that is used for
 - Digital IO each channel will consume 1 bit of process data.
 - Complex IO please refer to terminal documentation for consumed data size.

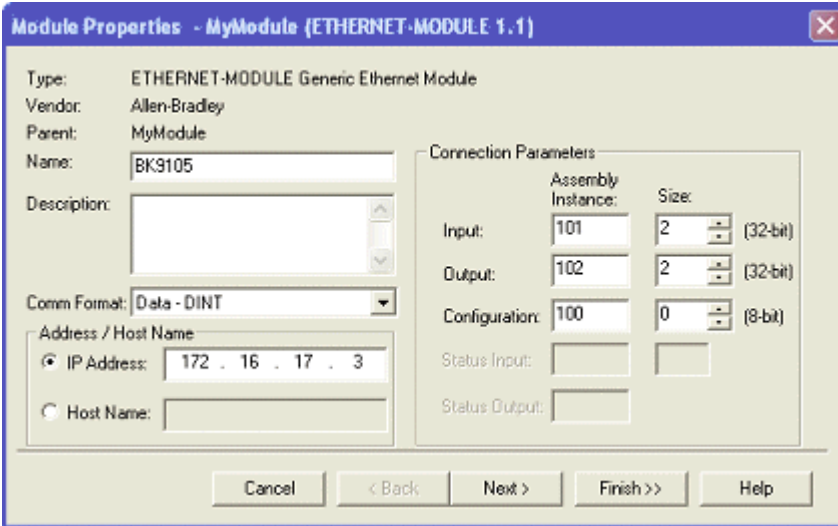

Fig. 51: First Steps - Configure the BK9105 in RSLogix

Working with IO data

Download the code to the controller unit, once you go online you will be able to toggle IO. Keep in mind that the first DINT is the Status for both the input and output data. At this point if you have the controller in RUN mode you will be able to toggle inputs and see the value in "bk9105:I.Data[1]" change and you should be able to update the values in "bk9105:O.Data[1]" and see the outputs change.

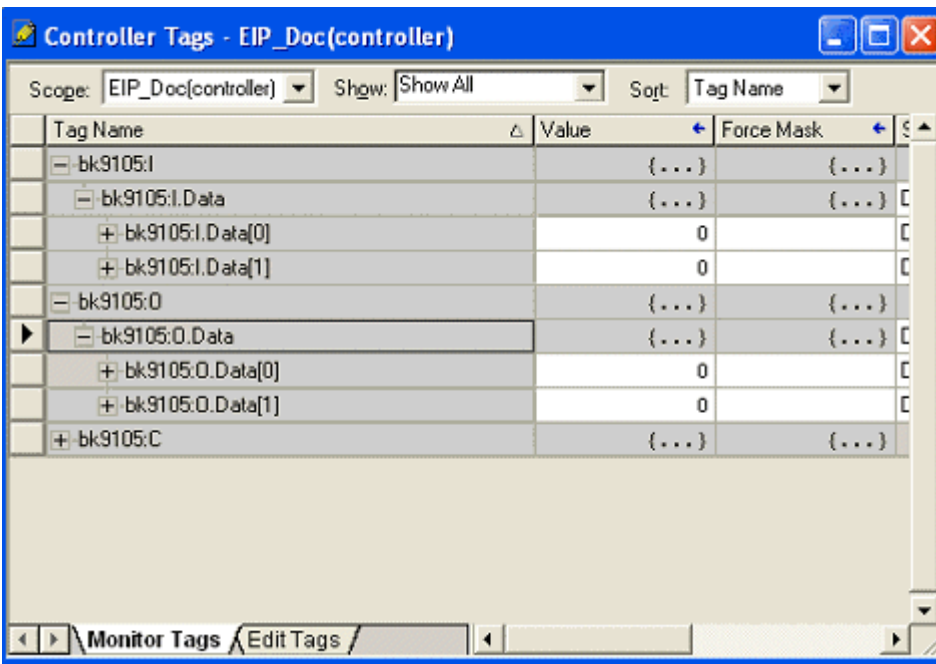

Fig. 52: First Steps - Work with IO data

6.2 First Steps - Example

● Mapping

i The BK9105 can be mapped as short integer (byte), integer (word), or double integer (double word). In the following description it is mapped as double integer!

Process Image

The figure below illustrates the hardware of the Beckhoff node in this example.

The process image table (I/O map) is displayed in double word format below the figure.

In order to properly configure the Ethernet Bridge, the process image of the Beckhoff BK9105 node must be determined. When the coupler is powered up, it automatically addresses the I/O modules of the node. The data for complex modules (modules using 2 or more bytes) are mapped first in the process image in the order of their physical position after the coupler. As such, they start at Double word 3. Following this, the digital modules are grouped into the next available Integer. The bits are arranged in the order of the modules location. When the number of digital points exceeds 32 (1-double integer), the coupler automatically starts the next Double Integer.

Note: The modules can be mapped as Byte, Word, or Double Word. The example below maps them as Double Word, using 2 digital input cards (KL1104, KL1408), 2 digital output cards (KL2134, KL2408), 1 four channel analog input card (KL3064), 1 two channel analog output card (KL4002), and 1 High speed counter card (KL5101).

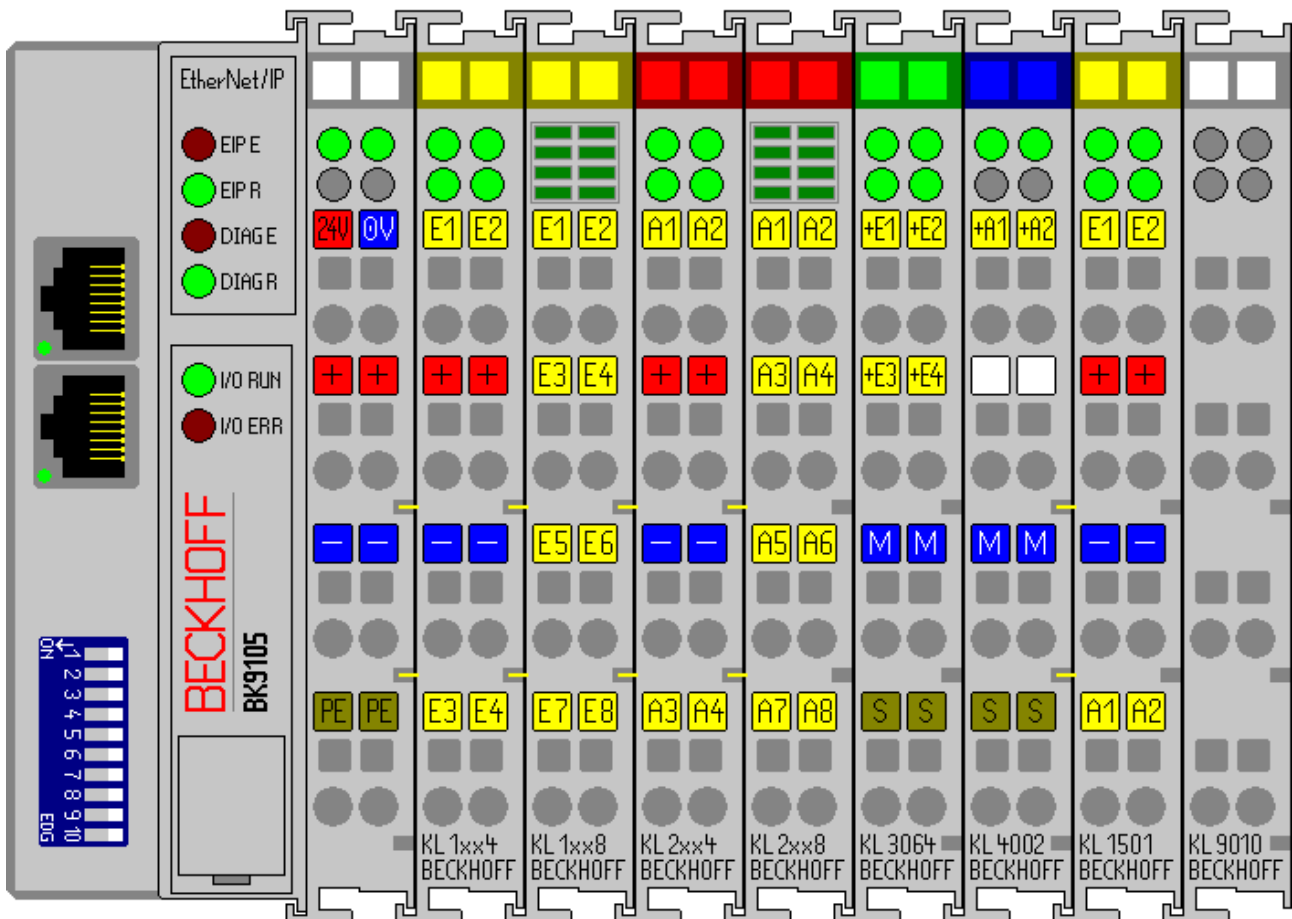

Fig. 53: Example of a Bus Terminal Block

Input Process Image

- Double Word 0: BK9105 Status
- Double Word 1: Channel 1 KL3064 (High Word) and Status (Low Word)

- Double Word 2: Channel 2 KL3064 (High Word) and Status (Low Word)
- Double Word 3: Channel 3 KL3064 (High Word) and Status (Low Word)
- Double Word 4: Channel 4 KL3064 (High Word) and Status (Low Word)
- Double Word 5: Channel 1 KL4002 (High Word) and Status (Low Word)
- Double Word 6: Channel 2 KL4002 (High Word) and Status (Low Word)
- Double Word 7: Data In(0) (High Word) and Status (Low Word)
- Double Word 8: KL1104 bit 16-19, KL14008 bit 20-27 the remainder bits are not used (High Word) and Data In (1) KL1501(Low Word)

Output Process Image

- Double Word 0: BK9105 Control
- Double Word 1: Channel 1 KL3064 (High Word) and Status (Low Word)
- Double Word 2: Channel 2 KL3064 (High Word) and Status (Low Word)
- Double Word 3: Channel 3 KL3064 (High Word) and Status (Low Word)
- Double Word 4: Channel 4 KL3064 (High Word) and Status (Low Word)
- Double Word 5: Channel 1 KL4002 (High Word) and Status (Low Word)
- Double Word 6: Channel 2 KL4002 (High Word) and Status (Low Word)
- Double Word 7: Data Out (0) (High Word) and Status (Low Word)
- Double Word 8: KL1104 bit 16-19, KL14008 bit 20-27 the remainder bits are not used (High Word) and Data (1) KL1501(Low Word)

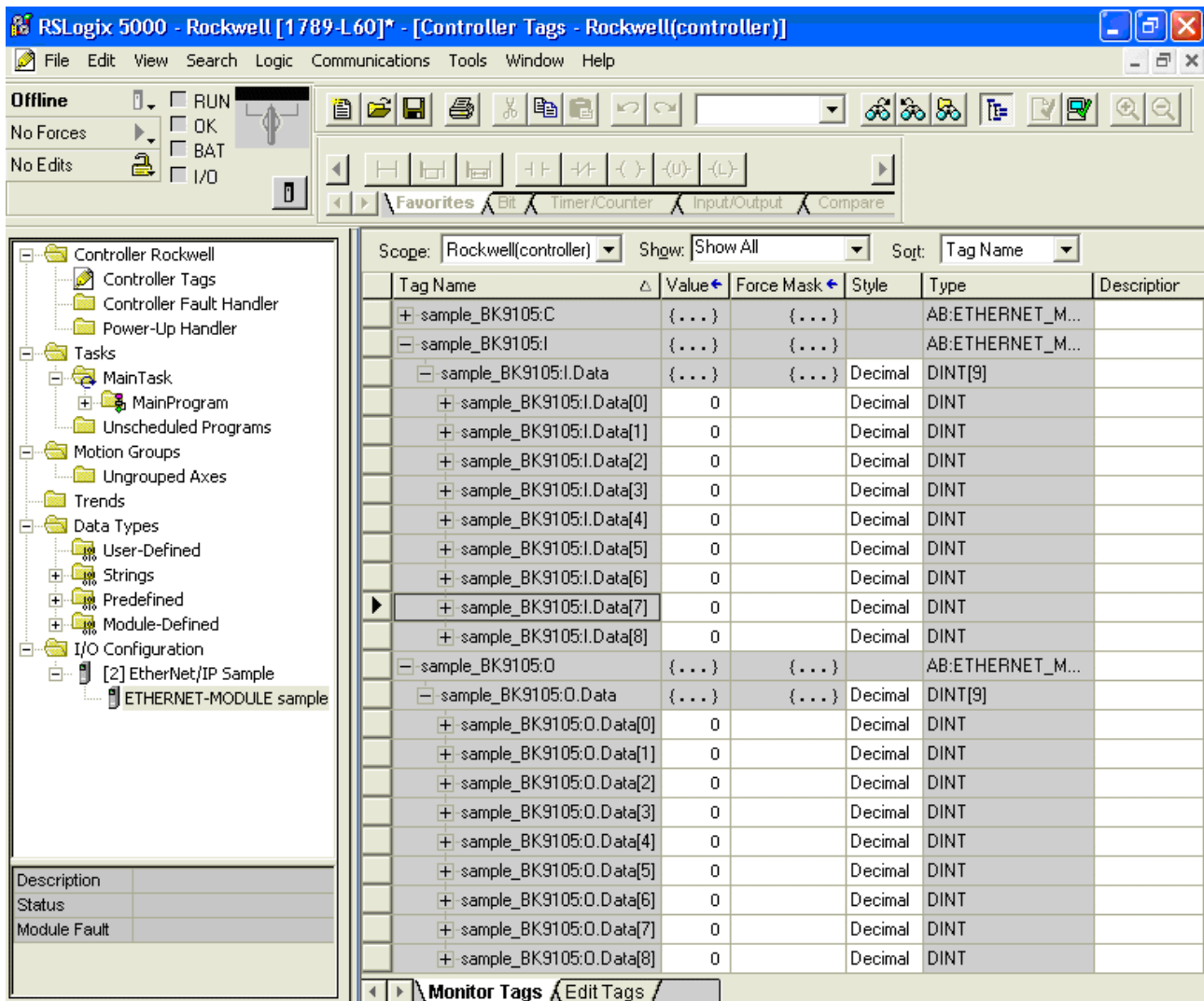

Fig. 54: Ethernet Module Sample

This is what the Controller Tags should look like. The graphic below illustrates exactly where one would look to find the Data In (1) KL1501 as well as the third digital output, KL2134 channel 3.

[-] sample_BK9105:I.Data[8]	0
sample_BK9105:I.Data[8].0	0
sample_BK9105:I.Data[8].1	0
sample_BK9105:I.Data[8].2	0
sample_BK9105:I.Data[8].3	0
sample_BK9105:I.Data[8].4	0
sample_BK9105:I.Data[8].5	0
sample_BK9105:I.Data[8].6	0
sample_BK9105:I.Data[8].7	0
sample_BK9105:I.Data[8].8	0
sample_BK9105:I.Data[8].9	0
sample_BK9105:I.Data[8].10	0
sample_BK9105:I.Data[8].11	0
sample_BK9105:I.Data[8].12	0
sample_BK9105:I.Data[8].13	0
sample_BK9105:I.Data[8].14	0
sample_BK9105:I.Data[8].15	0

This is the 16 bit value of KL1501's Data In (1)

Fig. 55: KL1501's Data In

+ sample_BK9105:0.Data[7]	0	Decimal	DINT
- sample_BK9105:0.Data[8]	0	Decimal	DINT
sample_BK9105:0.Data[8].0	0	Decimal	BOOL
sample_BK9105:0.Data[8].1	0	Decimal	BOOL
sample_BK9105:0.Data[8].2	0	Decimal	BOOL
sample_BK9105:0.Data[8].3	0	Decimal	BOOL
sample_BK9105:0.Data[8].4	0	Decimal	BOOL
sample_BK9105:0.Data[8].5	0	Decimal	BOOL
sample_BK9105:0.Data[8].6	0	Decimal	BOOL
sample_BK9105:0.Data[8].7	0	Decimal	BOOL
sample_BK9105:0.Data[8].8	0	Decimal	BOOL
sample_BK9105:0.Data[8].9	0	Decimal	BOOL
sample_BK9105:0.Data[8].10	0	Decimal	BOOL
sample_BK9105:0.Data[8].11	0	Decimal	BOOL
sample_BK9105:0.Data[8].12	0	Decimal	BOOL
sample_BK9105:0.Data[8].13	0	Decimal	BOOL
sample_BK9105:0.Data[8].14	0	Decimal	BOOL
sample_BK9105:0.Data[8].15	0	Decimal	BOOL
sample_BK9105:0.Data[8].16	0	Decimal	BOOL
sample_BK9105:0.Data[8].17	0	Decimal	BOOL
sample_BK9105:0.Data[8].18	0	Decimal	BOOL
sample_BK9105:0.Data[8].19	0	Decimal	BOOL
sample_BK9105:0.Data[8].20	0	Decimal	BOOL
sample_BK9105:0.Data[8].21	0	Decimal	BOOL
sample_BK9105:0.Data[8].22	0	Decimal	BOOL

This is the single bit value of KL2134, channel 3

Fig. 56: Single bit value of KL2134, channel 3

Open RSLogix 5000 and create a new PLC project

When creating a new project make sure to select the correct controller type and controller settings. This example uses a SoftLogix Virtual Chasis, with the BK9105 (Beckhoff EthernetIP Bus coupler).

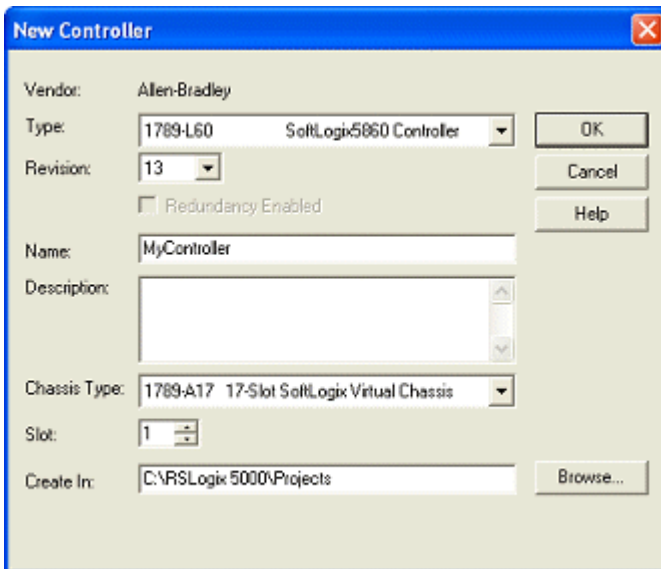

Fig. 57: Example - Create a new PLC project

Add an Ethernet IP Module

Add the main communications module. Be sure to know the IP address of the card that is setup as the Ethernet IP card. That address will have to be set in the module settings along with the slot the card is in.

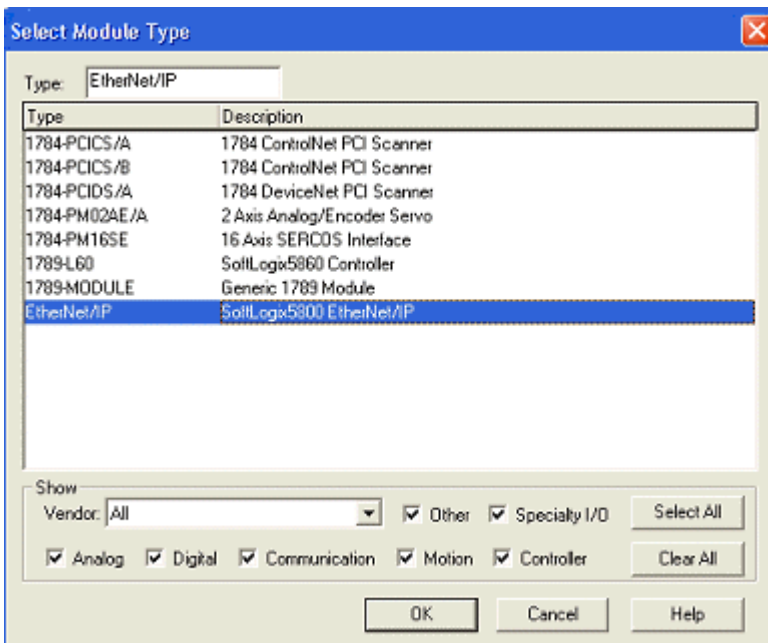

Fig. 58: Example - Add an Ethernet IP Module

Add an Ethernet IP Box

When adding the BK9105 box, select the "ETHERNET-MODULE", since it is a generic Ethernet/IP device, and it will be configured to work with the BK9105.

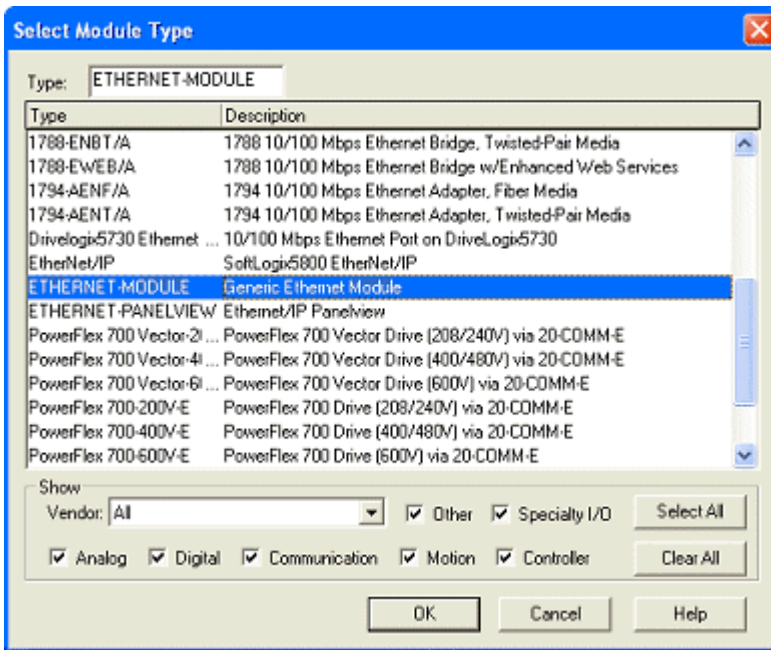

Fig. 59: Example - Add an Ethernet IP Box

Configuring the BK9105 in RSLogix

The example uses two KL1012 terminals and two KL2032 terminals. These cards gave 2 total words of input and output data. On the properties dialog, change some of the box settings. Please read the following for recommendations on settings:

- IP Address (Refer to IP Address section of documentation)
- The Assembly Instances will be as follows:
 - Input: 101
 - Output: 102
 - Configuration: 100
- Things to keep in mind when entering the data size for I/O:
 - There will always be 4 bytes of input and 4 bytes of output data used.
 - Digital IO: Each channel will consume 1 bit of process data.
 - Complex IO: Please refer to terminal documentation for consumed data size.

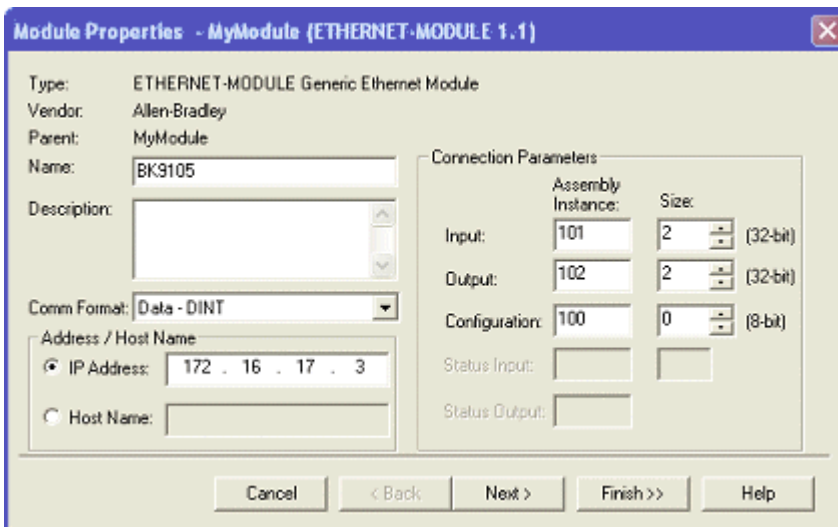

Fig. 60: Example - Configure the BK9105 in RSLogix

Working with IO data

Download the code to the controller unit. Go online to toggle IO. Keep in mind that the first DINT is the Status for both the input and output data. At this point, if the controller is in RUN mode, toggle inputs to see the value in "bk9105:I.Data[1]" change. One should be able to update the values in "bk9105:O.Data[1]" and see the outputs change.

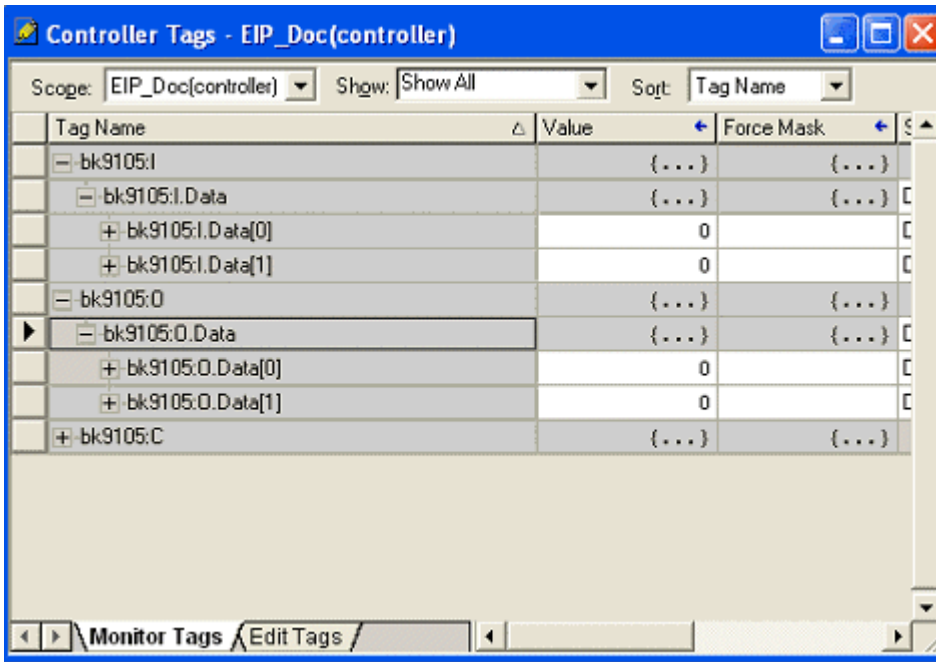

Fig. 61: Example - Work with IO data

6.3 General operating conditions

The following conditions must be met in order to ensure flawless operation of the fieldbus components.

Environmental conditions

Operation

The components may not be used without additional protection in the following locations:

- in difficult environments, such as where there are corrosive vapors or gases, or high dust levels
- in the presence of high levels of ionizing radiation

Condition	Permissible range
Permissible ambient temperature during operation	see technical data
Installation position	variable
Vibration resistance	According to EN 60068-2-6
Shock resistance	According to EN 60068-2-27
EMC resistance	According to EN 61000-6-2
Emission	According to EN 61000-6-4

Transport and storage

Condition	Permissible range
Permissible ambient temperature during storage	-25 °C... +85 °C
Relative humidity	95 %, no condensation
Free fall	up to 1 m in the original packaging

Protection classes and types

Condition	Permissible range
Protection class in accordance with IEC 536 (VDE 0106, Part 1)	A protective conductor connection to the mounting rail is necessary!
Protection class conforms to IEC 529	IP20 (protection against contact with a standard test finger)
Protection against foreign objects	Less than 12 mm in diameter
Protection against water	no protection

Component identification

Every supplied component includes an adhesive label providing information about the product's approvals. For example, on the BK2000:

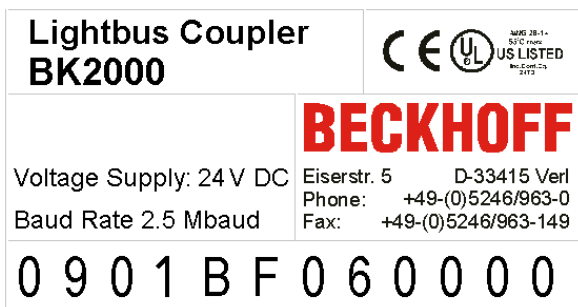

Fig. 62: Sticker with information about the BK2000 Bus Coupler certification

The following information is printed on the label:

Printed item	Meaning for this label
Precise product identification	Lightbus Coupler BK2000
Supply voltage	24 V _{DC}
Data transfer rate	2.5 Mbit/s
Manufacturer	Beckhoff Automation GmbH
CE mark	Conformity mark
UL mark	Mark for UL approval. UL stands for the Underwriters Laboratories Inc., the leading certification Organisation for North America, based in the USA. C = Canada, US = USA, LISTED 22ZA (the test results can be inspected under this entry)
Production identification	From left to right, this sequence of characters indicates the week of production (2 characters), the year of production (2 characters), the software version (2 characters) and hardware version (2 characters), along with any special indications (4 characters). This case therefore is a BK2000 - produced in the 9th calendar week - in the year 2001 - containing the BF firmware version - and using the 6th hardware version - with no special indications

6.4 Test Standards for Device Testing

EMC

EN 61000-6-2

EN 61000-6-4

Vibration resistance

EN 60068-2-6 Vibration Testing

EN 60068-2-27/29 Shock Testing

6.5 Bibliography

TCP/IP

TCP/IP (English)

Illustrated, Volume1 The Protocols

by W. Richard Stevens

Publisher: ADDISON-WESLEY Longmann Verlag

TCP/IP (German)

Aufbau und Betrieb eines TCP/IP Netzes (Structure and Operation of a TCP/IP Network)

by Kevin Washburn and Jim Evans

Publisher: ADDISON-WESLEY Longmann Verlag

Modbus/TCP

<http://www.modicon.com/>

<http://www.modbus.org>

TwinCAT

Beckhoff Information System

<http://infosys.beckhoff.com>

6.6 List of Abbreviations

ADS

Automation Device Specification.

IP (20)

Bus Terminal protection class

IPC

Industrial PC

I/O

Inputs and outputs

K-Bus

Terminal bus

KS2000

Configuration Software for Bus Terminals, Bus Coupler, Bus Terminal Controller, Fieldbus Box Modules and so on

PE

The PE power contact can be used as a protective earth.

TwinCAT

The Windows Control and Automation Technology

6.7 Support and Service USA

Beckhoff USA offers comprehensive support and service, making available fast and competent assistance with all questions related to Beckhoff products and system solutions.

- support
- design, programming and commissioning of complex automation systems
- and extensive training program for Beckhoff system components

Requirements

Hotline: +1 (952) 890 0000 or 1 877 TwinCAT

Fax: +1 (952) 890 2888

e-mail: support.usa@beckhoff.com

6.8 Support and Service

Beckhoff and their partners around the world offer comprehensive support and service, making available fast and competent assistance with all questions related to Beckhoff products and system solutions.

Beckhoff's branch offices and representatives

Please contact your Beckhoff branch office or representative for local support and service on Beckhoff products!

The addresses of Beckhoff's branch offices and representatives round the world can be found on her internet pages:

<http://www.beckhoff.com>

You will also find further documentation for Beckhoff components there.

Beckhoff Headquarters

Beckhoff Automation GmbH & Co. KG

Huelshorstweg 20
33415 Verl
Germany

Phone: +49 5246 963 0
Fax: +49 5246 963 198
e-mail: info@beckhoff.com

Beckhoff Support

Support offers you comprehensive technical assistance, helping you not only with the application of individual Beckhoff products, but also with other, wide-ranging services:

- support
- design, programming and commissioning of complex automation systems
- and extensive training program for Beckhoff system components

Hotline: +49 5246 963 157
Fax: +49 5246 963 9157
e-mail: support@beckhoff.com

Beckhoff Service

The Beckhoff Service Center supports you in all matters of after-sales service:

- on-site service
- repair service
- spare parts service
- hotline service

Hotline: +49 5246 963 460
Fax: +49 5246 963 479
e-mail: service@beckhoff.com

Table of figures

Fig. 1	BK9055	8
Fig. 2	BK9105	9
Fig. 3	Dimensions	14
Fig. 4	Electrical isolation	17
Fig. 5	Start-up behaviour of the Bus Coupler	21
Fig. 6	Network classes.....	22
Fig. 7	DIP switch.....	23
Fig. 8	Beckhoff BootP Server - DIP switch settings for statically stored IP address.....	25
Fig. 9	Beckhoff BootP Server - DIP switch settings for dynamically set IP address.....	25
Fig. 10	Beckhoff BootP server configuration - Start.....	26
Fig. 11	Beckhoff BootP server configuration - Time Stamp.....	27
Fig. 12	Rockwell BOOTP/DHCP Server 2.3 - MAC address.....	28
Fig. 13	Rockwell BOOTP/DHCP Server 2.3 - successful addressing	29
Fig. 14	Testing the IP address using the Ping command	30
Fig. 15	EthernetIP Tag Wizard	34
Fig. 16	EthernetIP Tag Wizard - Save as type	35
Fig. 17	EthernetIP Tag Wizard - EthernetIPMaster.txt	35
Fig. 18	EthernetIP Tag Wizard - EtherNetIPConfigTool	36
Fig. 19	EthernetIP Tag Wizard - Enter IP address	36
Fig. 20	EthernetIP Tag Wizard - Automatic adding Local IO	36
Fig. 21	EthernetIP Tag Wizard - Adding the IO to cour configuration.....	37
Fig. 22	EthernetIP Tag Wizard - selections	37
Fig. 23	EthernetIP Tag Wizard - Mapping	38
Fig. 24	EthernetIP Tag Wizard - Save To L5K file.....	38
Fig. 25	EthernetIP Tag Wizard - choose the correct Ethernet IP master.....	39
Fig. 26	EthernetIP Tag Wizard select the correct Ethernet IP master	39
Fig. 27	EthernetIP Tag Wizard - select the correct path to the stored .L5K file.....	39
Fig. 28	EthernetIP Tag Wizard - ABL5k.L5K	40
Fig. 29	EthernetIP Tag Wizard - open the L5K file	40
Fig. 30	EthernetIP Tag Wizard - Safe the Imported Project	41
Fig. 31	EthernetIP Tag Wizard - check out all of the new IO.....	42
Fig. 32	EthernetIP Tag Wizard - Controller tags.....	43
Fig. 33	Export to Rockwell - Create a master Ethernet IP	44
Fig. 34	Export to Rockwell - Save as the project as .L5k format, step 1	44
Fig. 35	Export to Rockwell - Save as the project as .L5k format, step 2	45
Fig. 36	Export to Rockwell - export with the push button AB CSV	45
Fig. 37	Export to Rockwell - Select the created file L5k	46
Fig. 38	Export to Rockwell - open the ABL5K.L5K	46
Fig. 39	Export to Rockwell - Select the file ABL5K.L5K.....	47
Fig. 40	Export to Rockwell - Save the project as ACD	47
Fig. 41	Export to Rockwell - Read the import configuration.....	48
Fig. 42	Export to Rockwell - Read the import configuration with comments.....	49
Fig. 43	BK9105 Diagnostic LEDs	50
Fig. 44	BK9055, BK9105 - LEDs	51

Fig. 45	Example for Error Code and Error Argument	52
Fig. 46	First Steps - Addressing - Step 1	54
Fig. 47	First Steps - Addressing - Step 2	55
Fig. 48	First Steps - Create a new PLC project	55
Fig. 49	First Steps - Add Ethernet IP Module	56
Fig. 50	First Steps - Add Ethernet IP Box	56
Fig. 51	First Steps - Configure the BK9105 in RSLogix	57
Fig. 52	First Steps - Work with IO data	57
Fig. 53	Example of a Bus Terminal Block	58
Fig. 54	Ethernet Module Sample	59
Fig. 55	KL1501's Data In	60
Fig. 56	Single bit value of KL2134, channel 3	61
Fig. 57	Example - Create a new PLC project	62
Fig. 58	Example - Add an Ethernet IP Module	62
Fig. 59	Example - Add an Ethernet IP Box	63
Fig. 60	Example - Configure the BK9105 in RSLogix	63
Fig. 61	Example - Work with IO data	64
Fig. 62	Sticker with information about the BK2000 Bus Coupler certification	65