



EUROTHERM
DRIVES

5701 MICROTACH

Product Manual

© Copyright Eurotherm Drives Limited 1998

All rights strictly reserved. No part of this document may be stored in a retrieval system, or transmitted in any form or by any means to persons not employed by a Eurotherm group company without written permission from Eurotherm Drives Ltd. Although every effort has been taken to ensure the accuracy of this document it may be necessary, without notice, to make amendments or correct omissions. Eurotherm Drives cannot accept responsibility for damage, injury, or expenses resulting therefrom.

WARRANTY

Eurotherm Drives warrants the goods against defects in design, materials and workmanship for the period of 12 months from the date of delivery on the terms detailed in Eurotherm Drives Standard Conditions of Sale IA058393C.

Eurotherm Drives reserves the right to change the content and product specification without notice.

© COPYRIGHT in this document is reserved to Eurotherm Drives Ltd.

INTENDED USERS

This manual is to be made available to all persons who are required to configure, install or service the equipment described herein or any other associated operation.

NOTE: Warranty is invalidated if painted screws are removed

Contents

Chapter 1 General Description	1-1
PRINCIPLE OF OPERATION	1-1
ELECTRICAL CONNECTION.....	1-1
ENCODER TRANSMISSION RANGE	1-2
MOTOR COUPLINGS.....	1-3
MOUNTING THE MICROTACH	1-3
Chapter 2 Product Information	2-1
OUTLINE DRAWINGS.....	2-1
MECHANICAL SPECIFICATION.....	2-2
ELECTRICAL SPECIFICATIONS	2-2
ENVIRONMENTAL CHARACTERISTICS	2-3
MATERIALS USED	2-3

Chapter 1 General Description

The Eurotherm Drives “MICROTACH” is a combination of micro-electronics and laser technology packaged into a rugged industrial housing.

To provide high accuracy speed and position measurement an incremental encoder disk is used (1000 lines/rev) together with micro-electronics to facilitate the use of single fibre optic transmission of the encoder pulses. Fibre optic transmission of sensitive information in an electrically noisy environment is a simple and sensible step giving the supreme advantage of noise free signal transmission over considerable distances. Fibre optic technology has evolved to produce “user friendly” plastic fibre cable with simple connectors suitable for factory floor use.

The housing is an industry standard flange mounting and includes shielded bearings as standard to discourage dirt and oil ingress whilst providing a high degree of mechanical integrity. The removable terminal end cover and cable gland are also sealed.

The encoder is nominally powered by the 570 series equipment to which it is connected using standard cable (screens are not necessary) at a potential of 12.5 - 40V DC. (The power supply terminals being independent of polarity).

PRINCIPLE OF OPERATION

The position of an application proven incremental encoder disk mounted on the shaft of the microtach is sensed by optical receivers. The disk contains 3 tracks, A, B, and Marker. The A and B pulse trains are of the same frequency but displaced by 90 degrees. The frequency of the A and B pulse trains are proportional to the rotational speed of the shaft whilst the 90 degree phase displacement determines the direction of rotation of the shaft. The marker signal is a once per rev signal used in register position applications.

The information contained in the three encoder waveforms (A, B, M) are digitally compressed into a serial data packet which is transmitted along the fibre optic at a 500khz packet rate.

The receive decoding is the reverse process and will produce the three pulse trains with no distortion. The hardware for this process is contained within the 570 series product.

ELECTRICAL CONNECTION

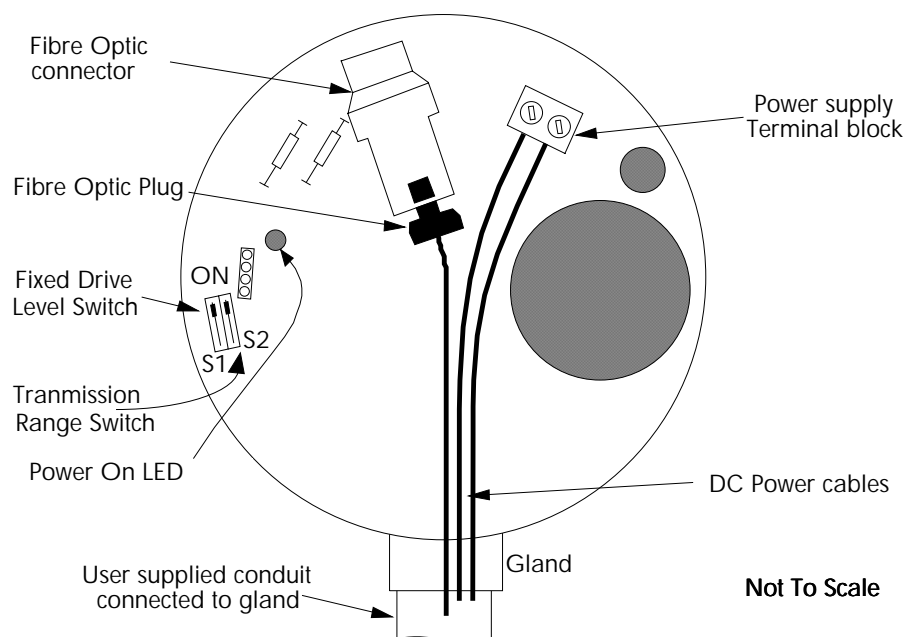

Figure 1-1 Diagram Showing Inside the End Plate

The customer connections to the 5701 consist of a single fibre optic plug and two standard wire terminals for the power supply. The customer should firstly remove the end plate of the encoder by removing the two retaining screws. Once the end plate has been removed the gland insert should be unscrewed from the body section. The fibre optic cable and power supply cables should be prepared and cut to the correct length, they may then be inserted through the gland and rubber holder.

Once the cables have been placed through the body section of the gland, the fibre optic plug may be connected. The termination procedure for the fibre optic plug is a simple three step procedure and is detailed in Figure 1-2. Once the plug has been attached to the fibre optic, the plug may be pushed into the fibre optic socket until it clicks home. After connecting the fibre optic plug the power supply cables may be connected using the screw terminals provided. It should be noted that the polarity of the terminals is unimportant.

After the fibre optic and power supply cables have been connected, the rubber holder should be pushed into the gland. It is important that no slack, or loops of, fibre optic cable are left inside the encoder body. (See "minimum bend radius" on page 2-2). The exit of the fibre optic from the body should be as smooth as possible. The gland should now be tightened ensuring the cable is not twisted. The end plate is then replaced and secured. Note that the fibre optic plug may be withdrawn through the body gland to allow replacement and strip down of the completed installation.

3-Step Installation Procedure

The following is intended as a general description.

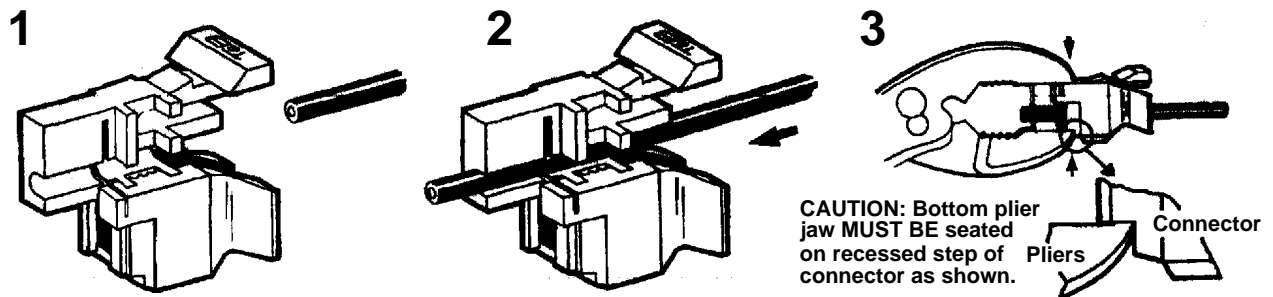

Connector plug is packaged ready to use. No fibre preparation necessary. The fibre should protrude through the housing a minimum of 1cm. Press down the fibre clamp (using plier) until it is fully butted in the housing. The termination is complete.

Figure 1-2 Termination Procedure Diagram

This procedure is reproduced by kind permission of Thomas and Betts Limited, Foster Avenue, Woodside Park, Dunstable, Beds.

ENCODER TRANSMISSION RANGE

If the customer required a transmission distance of greater than 40m the Eurotherm Drives repeater box must be used to boost the light signal. This box uses the same method of termination as the encoder and is connected into fibre optic and power supply lines in the same way as the encoder which is detailed above. Details of this product may be found on page 2-2. (Also see 5702 Manual HA056768).

Verification of operation should be performed by observing the speed or position feedback signals from the Microtach receiver. Here, the appropriate product manual should be consulted.

The two receiver LED's:-

Fixed light

No light

should be illuminated, and this gives some indication as to correct operation.

The drive level switch S1 and resistor which can be seen under the end cover, are to allow measurement and adjustment of the fibre optic launch power. The drive level has been carefully specified to allow the fibre drive lengths indicated below. Further adjustment of these components should not be necessary, and should only be performed by Eurotherm Drives personnel, normal position for S1 is OFF.

S1	S2	
OFF	OFF	Normal operation 5 - 20 metres
OFF	ON	Normal operation 20 - 40 metres
ON	OFF	Constant Light output
ON	ON	Constant Light output

NOTE: CONSTANT LIGHT OUTPUT ALLOWS CABLE ATTENUATION MEASUREMENTS. THIS IS NOT FOR NORMAL OPERATION.

Further commissioning should be carried out according to the appropriate drive product manual.

MOTOR COUPLINGS

To ensure the full benefits of accuracy and linearity are obtained the encoder must be connected to the motor shaft by a good quality torsionally stiff coupling. We strongly recommend the Thomas disk type coupling, details of which are included at the end of this manual under the accessories kit.

MOUNTING THE MICROTACH

The Microtach is designed for use as a speed and position sensor for industrial motors. It is available in two industry standard flange types to suit common motor adapters in Europe and the USA.

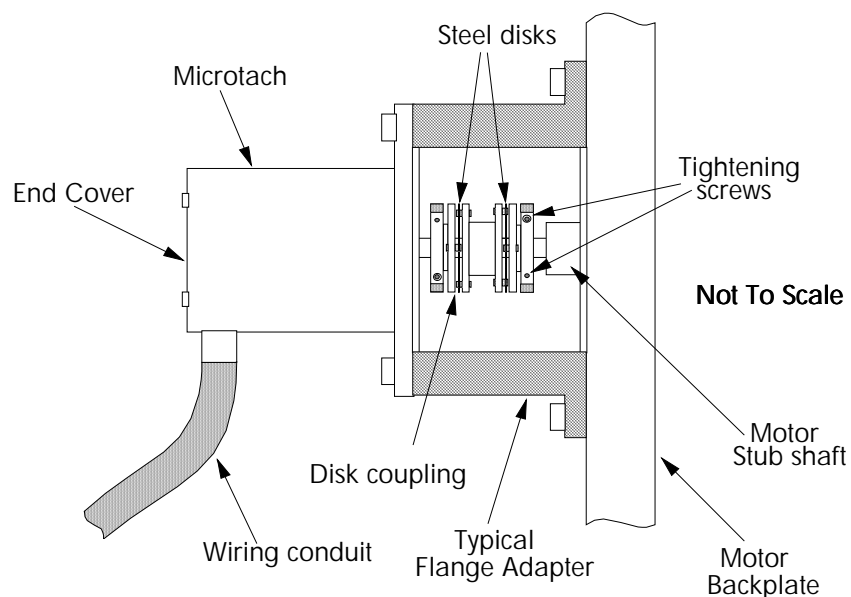

Figure 1-3 Typical Microtach Mounting Arrangement

A suitable flange adapter should be used to mount the Microtach onto the back of the motor. The flange adapter is used to convert between the motor back plate and the Microtach flange as described previously.



Caution

The Microtach contains a standard electrical pulse encoder, which uses a glass disk.

It is most important that the Microtach is handled with care during installation.

Excessive shock will damage the glass disk, and this will invalidate the warranty.

A stub shaft should be provided to allow the Microtach to be connected to the motor shaft. This is shown in Figure 1-3.

It is most important with any tachometer transducer, that a good quality coupling is used to connect to the motor shaft. For the Microtach, the recommended coupling is a spring disk type. This has a high torsional stiffness and allows some misalignment of the two shafts. The part number of this coupling is given on page 2-3.

To mount the coupling onto the shaft, ensure that the tightening screws are loosened, and slide the coupling over the appropriate shaft. Tightening the screws will cause the coupling to grip the shaft. There is no key way provided on the Microtach shaft, and this is not necessary.

Ensure that the steel disks of the coupling are not strained in any way, or the life will be severely limited. The steel disks are shown in Figure 1-3.



Caution

The shaft of the Microtach is precision machined to close tolerances. The shaft should not be machined or otherwise altered. This may produce excessive shock within the Microtach which could damage the glass disk. Any alteration of the shaft will invalidate the warranty.

Chapter 2 Product Information

OUTLINE DRAWINGS

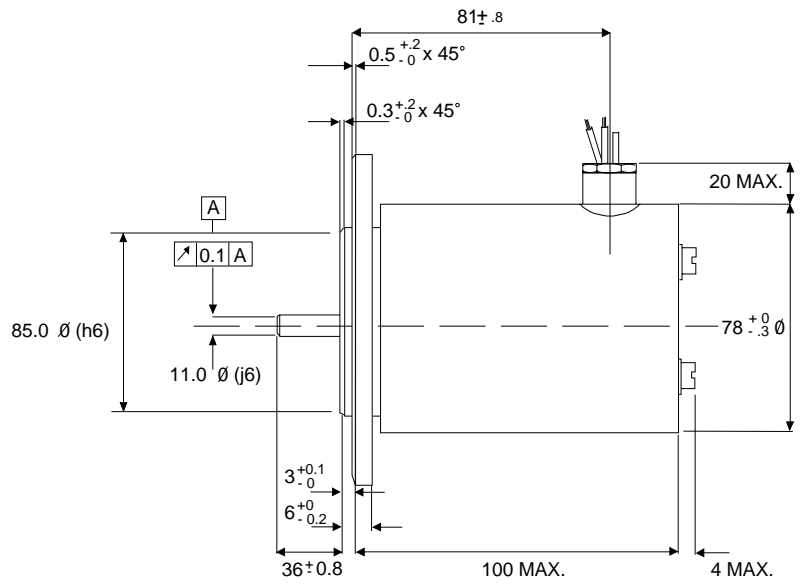
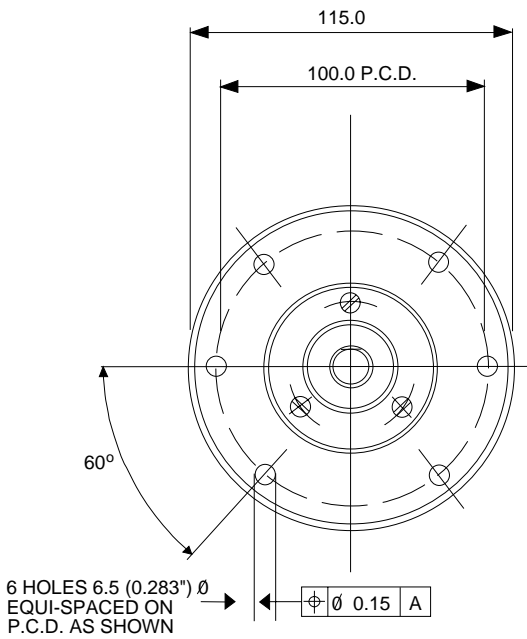

MICROTACH 5701/1, 5701/3, 5701/5, 5701/6 (EUROPEAN)

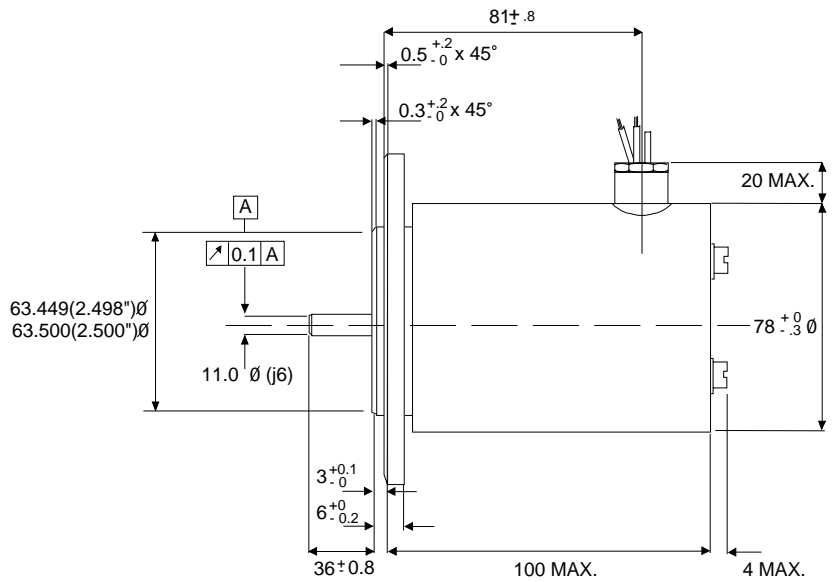
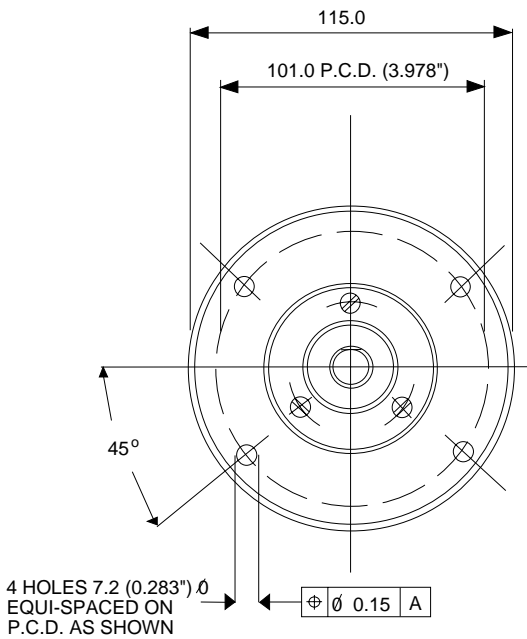

MICROTACH (AMERICAN) 5701/2
(NOT AVAILABLE)

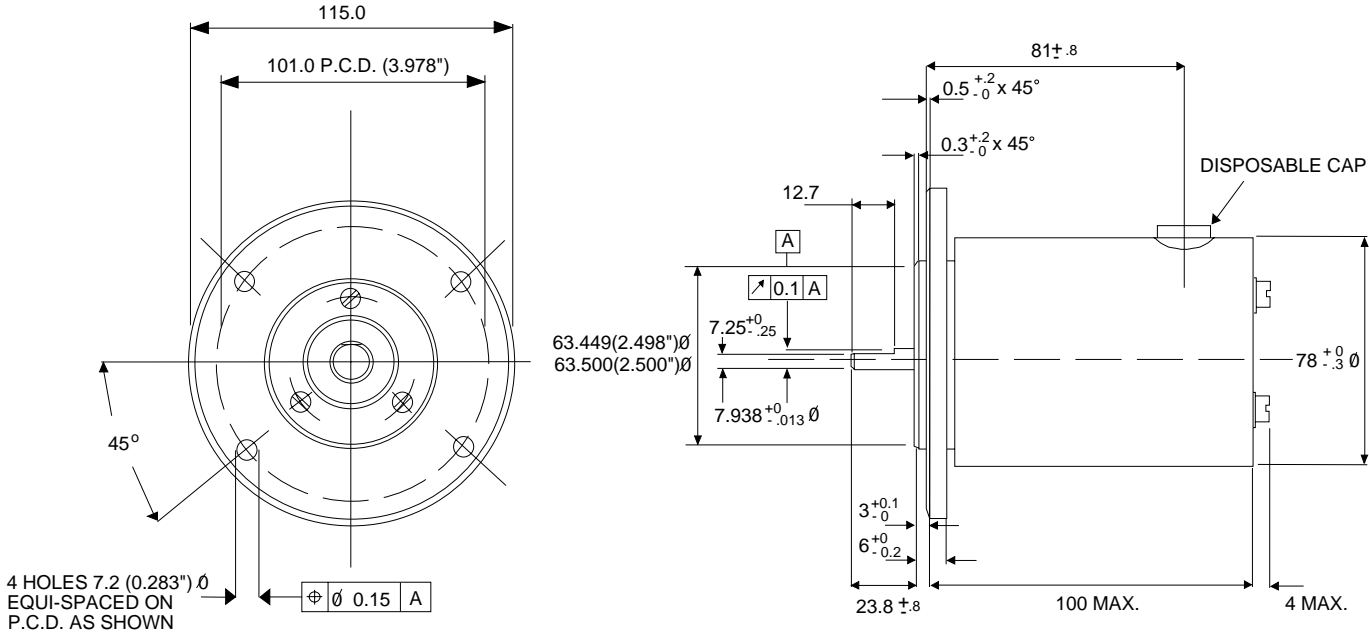

MICROTACH (AMERICAN) 5701/4

MECHANICAL SPECIFICATION

Dimensions:	See drawing above
Weight:	Approximately 0.12Kg.
Starting torque (at 25°C):	0.007 Nm max.
Speed (max):	3000 rpm.
Bearing life:	10 ⁹ revolutions.
Shaft loading:	Radial 110N Axial 130N
Bearing type:	Shielded.

ELECTRICAL SPECIFICATIONS

Power supply voltage:	12.5 - 40V DC (Polarity independent).
Power supply current:	60mA at 25V.
Power cable size:	1.5mm ² conductors. 3.0 O/D nom. cable.
Fibre optic cable:	1mm OD plastic fibre optic.
Transmission range:	20 - 40m (without repeaters).
Minimum bend radius:	50mm

ENVIRONMENTAL CHARACTERISTICS

Operating temperature:	0. to 70°C.
Storage temperature:	-25 to 80°C.
Humidity:	Up to 98% RH.
Protection (per DIN 40050 B1.1):	IP64.
Shock (nom):	20G, for 11 mS duration.
Vibration (nom):	10G, 5 - 2000Hz.

MATERIALS USED

Housing:	Aluminium alloy, natural finish.
Interior body:	Aluminium alloy.
Shaft:	Anti-magnetic stainless steel.
Bearings:	NMB 6000ZZ.
Light source:	Ga As Infrared light emitting diode.
Product Code	5701/1 European 6 hole flange. (RE0 444R). 1000ppr.
Not available -	5701/2 US 4 hold flange. 20mm Gland 1000ppr.
Not available -	5701/3 European 6 hold flange (RE0 444R). 500ppr.
	5701/4 US 4 hole flange. ½ NPT thread 1000ppr.
Accessory Kit	Disk coupling. BM054026*
	Fibre optic plug CI055069
	Fibre optic cable CM056316
	Fibre optic repeater box Model 5702/1

* Note the disk coupling specified is only suitable for the 5701/1, 2 and 3.

ISS.	MODIFICATION	ECN No.	DATE	DRAWN	CHK'D
1	Initial Issue of HA056252	2184	30.3.88	--	GDR
2	a) Drive range changed to from 3 to 45 metres. b) Bring manual format into line with STD. c) Include new outline drawings. d) Include data on 5701/3 and /4.	3389	25.10.90	--	GDR
3.	a) Drive range further modified to 5.40m. b) Non-preferred micro-tachs marked "not available".	3469	14.11.90	--	GDR
4.	Replaced:- SSD with Eurotherm Drives and changed address. Materials used: Housing replaced "& black anodising" with natural finish". Bearings replaced "ABEC5" with "NMB6000ZZ". Electrical Specifications: Transmission range removed "3m to" to 20-40m.	7874	18.2.93	--	CRM
5.	Re-written from Manuscript to Word VI. Added section on "Mounting the Microtach".	10599	15.2.96	FEP	CC
6.	Added Figure 1-1 to Electrical Connection. Added to Encoder Transmission Range "Verification of drive product manual".	12558	26.06.98	FEP	AFL
FIRST USED ON		MODIFICATION RECORD			
		5701 MICROTACH			
 EUROTHERM DRIVES		DRAWING NUMBER			SHT. 1
		ZZ056252			OF 1

SALES AND SERVICE

Eurotherm Drives a division of the Eurotherm International Group of Companies, provides sales and service capability world-wide through Eurotherm Drives Companies, Eurotherm Group Companies and Agents.

Head Office

Eurotherm Drives Limited
New Courtwick Lane
Littlehampton
West Sussex. BN17 7RZ

Tel: +44 (0)1903 737000
Fax: +44 (0)1903 737100
E-mail: firstname.lastname@drives.eurotherm.co.uk