

Panasonic®

Basic Operating Instructions

Digital Camera

Model No. **DMC-LX15**

LUMIX

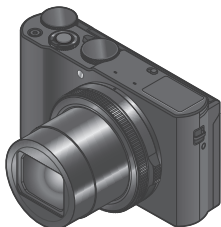

Please read these instructions carefully before using this product, and save this manual for future use.

More detailed operating instructions are available in “Operating Instructions for advanced features (PDF format)”. To read it, download it from the website. (→50)

Web Site: <http://www.panasonic.com>

Model number suffix “EB” denotes UK model.

EB

SQT1395
M0916KZ0

Dear Customer,

We would like to take this opportunity to thank you for purchasing this Panasonic Digital Camera. Please read these Operating Instructions carefully and keep them handy for future reference. Please note that the actual controls and components, menu items, etc. of your Digital Camera may look somewhat different from those shown in the illustrations in these Operating Instructions.

Carefully observe copyright laws.

- Recording of pre-recorded tapes or discs or other published or broadcast material for purposes other than your own private use may infringe copyright laws. Even for the purpose of private use, recording of certain material may be restricted.

Information for Your Safety

WARNING:

To reduce the risk of fire, electric shock or product damage,

- Do not expose this unit to rain, moisture, dripping or splashing.
- Use only the recommended accessories.
- Do not remove covers.
- Do not repair this unit by yourself. Refer servicing to qualified service personnel.

The socket outlet shall be installed near the equipment and shall be easily accessible.

■ Product identification marking

Product	Location
Digital camera	Bottom

■ About the AC adaptor (supplied)

CAUTION!

To reduce the risk of fire, electric shock or product damage,

- Do not install or place this unit in a bookcase, built-in cabinet or in another confined space. Ensure this unit is well ventilated.
- The unit is in the standby condition when the AC adaptor is connected. The primary circuit is always “live” as long as the AC adaptor is connected to an electrical outlet.

■ About the battery pack

CAUTION

- Danger of explosion if battery is incorrectly replaced. Replace only with the type recommended by the manufacturer.
- When disposing of the batteries, please contact your local authorities or dealer and ask for the correct method of disposal.
- Do not heat or expose to flame.
- Do not leave the battery(ies) in a car exposed to direct sunlight for a long period of time with doors and windows closed.

Warning

Risk of fire, explosion and burns. Do not disassemble, heat above 60 °C or incinerate.

■ Cautions for Use

- Do not use any other USB connection cables except the supplied one.
- Use a “High Speed HDMI micro cable” with the HDMI logo. Cables that do not comply with the HDMI standards will not work.
“High Speed HDMI micro cable” (Type D-Type A plug, up to 2 m (6.6 feet) long)

Keep this unit as far away as possible from electromagnetic equipment (such as microwave ovens, TVs, video games etc.).

- If you use this unit on top of or near a TV, the pictures and/or sound on this unit may be disrupted by electromagnetic wave radiation.
- Do not use this unit near cell phones because doing so may result in noise adversely affecting the pictures and/or sound.
- Recorded data may be damaged, or pictures may be distorted, by strong magnetic fields created by speakers or large motors.
- Electromagnetic wave radiation may adversely affect this unit, disturbing the pictures and/or sound.
- If this unit is adversely affected by electromagnetic equipment and stops functioning properly, turn this unit off and remove the battery or disconnect AC adaptor (supplied)/AC adaptor (DMW-AC10E: optional). Then reinsert the battery or reconnect AC adaptor and turn this unit on.

Do not use this unit near radio transmitters or high-voltage lines.

- If you record near radio transmitters or high-voltage lines, the recorded pictures and/or sound may be adversely affected.



Declaration of Conformity (DoC)

Hereby, "*Panasonic Corporation*" declares that this product is in compliance with the essential requirements and other relevant provisions of Directive 1999/5/EC.

Customers can download a copy of the original DoC to our R&TTE products from our DoC server:

<http://www.doc.panasonic.de>

Contact to Authorized Representative:

Panasonic Marketing Europe GmbH, Panasonic Testing Centre,
Winsbergring 15, 22525 Hamburg, Germany

This product on purpose to connect to access point of 2.4 GHz WLAN.

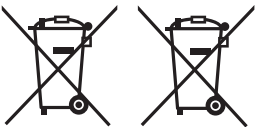

These symbols indicate separate collection of waste electrical and electronic equipment or waste batteries.

More detailed information is contained in "Operating Instructions for advanced features (PDF format)".

Contents

■ Information for Your Safety	2
-------------------------------------	---

Preparations

■ Before use	7
■ Standard accessories	8
■ Names and Functions of Main Parts	10
■ Inserting and removing the battery or SD memory card (optional)	12
■ Charging the battery	13
■ Setting the clock	15

Basics

■ Basic operations	16
■ Setting the menu	23

Recording

■ Taking pictures with automatic settings (Intelligent Auto Mode)	24
■ [Self Shot]	25
■ Recording 4K photos	26
■ [Post Focus] / [Focus Stacking]	30
■ Taking Pictures While Adjusting a Setting Automatically (Bracket Recording)	33
■ Recording Motion Picture/ 4K Motion Picture	34
■ [4K Live Cropping]	36

Playback

■ Viewing your pictures	38
■ [Light Composition]	39

Menu

■ Menu list	41
-------------------	----

Wi-Fi

■ What you can do with the Wi-Fi® function	44
■ Operating the camera by connecting it to a smartphone	45

Others

■ Downloading software	48
■ Reading the Operating Instructions (PDF format)	50
■ List of monitor displays	51
■ Q&A Troubleshooting	55
■ Specifications	57
■ Digital Camera Accessory System	61

■ About the symbols in the text

MENU Indicates that the menu can be set by pressing [MENU/SET] button.

In this Operating Instructions, steps for setting a menu item are described as follows:

MENU →  [Rec] → [Quality] → [.]

Before use

■ Camera handling

- Keep the camera away from excessive vibration, force, or pressure.
- The camera is not dust resistant, splash resistant, or waterproof.
Avoid using the camera in places with excessive dust or sand, or where water can come into contact with the camera.
- Do not allow camera to come into contact with pesticides or volatile substances (can cause surface damage or coating to peel).

■ Condensation (When the lens or the monitor is fogged up)

- Condensation may occur when the camera is exposed to sudden changes of temperature or humidity. Avoid these conditions, which may make the lens or monitor dirty, cause mould, or damage the camera.
- If condensation does occur, turn off the camera and wait about two hours before using it. Once the camera adjusts to the surrounding temperature, the fogging will clear naturally.

■ Caring for your camera

- To clean your camera, remove the battery, the DC coupler (DMW-DCC15A: optional) or a card, or disconnect the power plug from the outlet, and wipe with a soft, dry cloth.
- Do not press the monitor with excessive force.
- Do not press the lens with excessive force.
- Do not keep rubber or plastic products in contact with the camera for a long period of time.
- Do not use solvents such as benzene, thinner, alcohol, kitchen detergents, etc., to clean the camera, since it may deteriorate the external case or the coating may peel off.
- Do not leave the camera with the lens facing the sun, as rays of light from the sun may cause it to malfunction.
- Do not extend the supplied cord or cable.
- While the camera is accessing the card (for an operation such as picture writing, reading, deletion, or formatting), do not turn off the camera or remove the battery, card, AC adaptor (DMW-AC10E: optional) or DC coupler (DMW-DCC15A: optional).
- The data on the card may be damaged or lost due to electromagnetic waves, static electricity or breakdown of the camera or the card. We recommend storing important data on a PC etc.
- Do not format the card on your PC or other equipment. Format it on the camera only to ensure proper operation.

Standard accessories

Check that all the accessories are supplied before using the camera. Part numbers are as of October 2016. These may be subject to change.

<input type="checkbox"/> Battery pack DMW-BLH7E <ul style="list-style-type: none">• Charge the battery before use.• Battery pack is indicated as battery pack or battery in the text.	<input type="checkbox"/> Hand strap VFC4297
<input type="checkbox"/> AC adaptor SAE0012F	<input type="checkbox"/> USB connection cable K1HY04YY0106





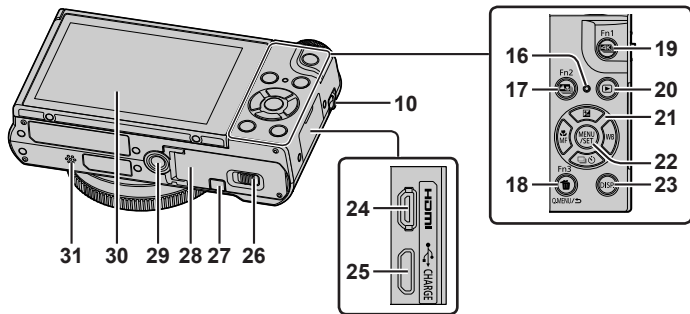
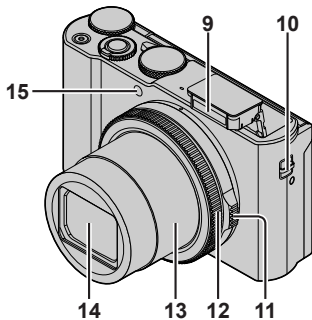
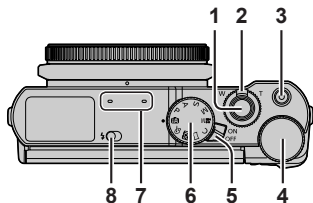

- **Cards are optional.** (SD Memory Card, SDHC Memory Card and SDXC Memory Card are indicated as card in the text.)
 - This unit is compatible with UHS-I UHS Speed Class 3 standard SDHC/SDXC memory cards.
 - The following SD standard-based cards can be used.
 - SD Memory Card (512 MB to 2 GB)/SDHC Memory Card (4 GB to 32 GB)/SDXC Memory Card (48 GB to 128 GB)
 - Depending on recording conditions, the required card differs.
- Consult the dealer or your nearest Service Centre if you lose the supplied accessories. (You can purchase the accessories separately.)
- Please dispose of all packaging appropriately.
- The illustrations and screens in this manual may differ from the actual product.

Names and Functions of Main Parts



- 1 Shutter button (→17)
 - 2 Zoom lever (→16)
 - 3 Motion picture button (→34)
 - 4 Rear dial (→21)
 - 5 Camera [ON/OFF] switch
 - 6 Mode dial (→18)
 - 7 Stereo microphone
 - 8 Flash open lever
 - 9 Flash
 - 10 Strap eyelet

- To prevent dropping, be sure to attach the supplied strap and fit it to your wrist.
 - 11 Aperture ring (→21)
 - 12 Control ring (→21)
 - 13 Lens barrel
 - 14 Lens
 - 15 Self-timer indicator/AF Assist Lamp
 - 16 Charging lamp (→13)/
Wi-Fi® connection lamp
 - 17  ([Post Focus]) button (→30)/
[Fn2] button
 - 18 [Q.MENU/↵] (Cancel) button/
 (Delete) button (→38)/
[Fn3] button
 - You can easily call some of the menu items and set them during recording.
 - 19  (4K photo mode) button (→26)/
[Fn1] button
 - 20  (Playback) button (→38)
 - 21 Cursor button (→19)
 - 22 [MENU/SET] button
 - 23 [DISP.] button
 - Use this to change display.
 - 24 [HDMI] socket
 - 25 [USB/CHARGE] socket (→13)
 - 26 Release lever (→12)
 - 27 DC coupler cover (→61)
 - 28 Card/Battery door (→12)
 - 29 Tripod mount
 - Do not attach this unit to tripods that have screws with a length of 5.5 mm (0.22 inch) or more. Doing so may damage this unit or the unit may not be secured properly on the tripod.
 - 30 Touch screen (→22)/monitor (→51)
 - 31 Speaker
- Always use a genuine Panasonic AC adaptor (DMW-AC10E: optional). (→61)
When using an AC adaptor (DMW-AC10E: optional), ensure that the Panasonic DC coupler (DMW-DCC15A: optional) and AC adaptor (DMW-AC10E: optional) are used. The optional DC coupler (DMW-DCC15) cannot be used.
 - [Fn4] to [Fn8] (→19) are touch icons. They are displayed by touching the  tab on the recording screen.

Inserting and removing the battery or SD memory card (optional)

Make sure that the camera is turned off.

1 Slide the release lever (A) to the [OPEN] position and open the card/battery door

2 Insert the battery and card, making sure that their orientation is correct

- Battery: Insert the battery all the way firmly and check that it is locked by lever (B).
- Card: Insert the card all the way firmly until it clicks. Do not touch the terminals on the back of the card.

3 Close the door

Slide the release lever to the [LOCK] position.

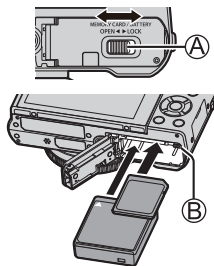

■ To remove

• To remove battery:

Move lever (B) in direction of arrow.

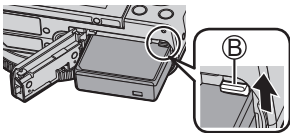

• To remove card:

Push the card until it clicks, then pull the card out.

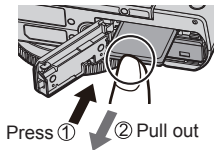

- Always use genuine Panasonic batteries (DMW-BLH7E).
- If you use other batteries, we cannot guarantee the quality of this product.
- Keep the Memory Card out of reach of children to prevent swallowing.

Charging the battery

- The battery that can be used with this unit is DMW-BLH7E.
- The battery is not charged when the camera is shipped. Charge the battery before use.
- We recommend charging in a location where the ambient temperature is between 10 °C and 30 °C (50 °F to 86 °F).

Insert the battery into the camera.
Make sure that the camera is turned off.

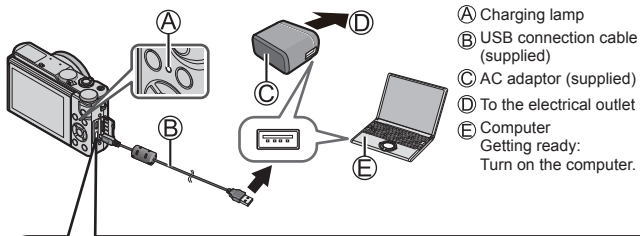

- Ⓐ Charging lamp
- Ⓑ USB connection cable (supplied)
- Ⓒ AC adaptor (supplied)
- Ⓓ To the electrical outlet
- Ⓔ Computer
Getting ready:
Turn on the computer.

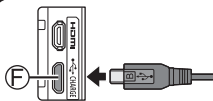

Ⓕ [USB/CHARGE] socket

- This terminal is located at the bottom when the camera is in an upright position.

- Always check the direction of the pins and hold the plug straight to insert or remove it. (If the cable is inserted in the wrong direction, the pins could become deformed and cause faulty operation.) Also, do not insert into the wrong socket. Doing so may cause damage to this unit.

■ Charging lamp

On: Charging in progress

Off: Charging stops (After charging stops, disconnect the camera from the electrical outlet or your computer.)

Flashing: Charging error (→55)

■ Charging time (When using the AC adaptor (supplied))

Approx. 130 min.

- The battery is a rechargeable lithium ion battery. If the temperature is too high or too low, the operating time of the battery will become shorter.
- The battery becomes warm after using and during and after charging. The camera also becomes warm during use. This is not a malfunction.
- **Do not leave any metal items (such as clips) near the contact areas of the power plug or near the batteries.**
- Do not use any other USB connection cables except the supplied one.
- Do not use any other AC adaptors except the supplied one.
- Do not use the AC adaptor (supplied) or the USB connection cable (supplied) with other devices.

Setting the clock

The clock is not set when the camera is shipped.

- 1 Turn the camera on
- 2 Press [MENU/SET]
- 3 Press ◀▶ to select the items (year, month, day, hour, minute), and press ▲▼ to set
- 4 Press [MENU/SET]
- 5 When [The clock setting has been completed.] is displayed, press [MENU/SET]
- 6 When [Please set the home area] is displayed, press [MENU/SET]
- 7 Press ◀▶ to set your home area and press [MENU/SET]

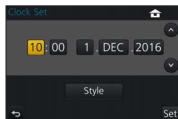

Basic operations

Zoom lever (Use zoom)

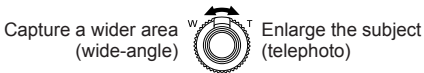

■ Zoom types and use

Optical Zoom:

You can zoom in without degrading the picture quality.

Maximum magnification: 3x

Extra optical zoom:

This function works when picture sizes with [EX] have been selected in [Picture Size]. Extra optical zoom allows you to zoom in using a higher zoom ratio than optical zoom, without degrading the picture quality.

Maximum magnification: 6x*

*Including the optical zoom ratio. The maximum zoom ratio varies depending on the picture size.

[i.Zoom]:

You can use the camera's intelligent resolution technology to increase the zoom ratio up to 2x higher than the original zoom ratio with limited deterioration of picture quality. (Up to 1.5x the original zoom ratio when [Picture Size] is set to [S]) Set the [i.Zoom] in the [Rec] menu to [ON].

[Digital Zoom]:

Zoom 4x further than Optical/Extra optical zoom. When [Digital Zoom] is used simultaneously with [i.Zoom], you can only increase the zoom ratio up to 2x. Note that, with Digital Zoom, enlarging will decrease picture quality. Set the [Digital Zoom] in the [Rec] menu to [ON].

- When [Live View Mode] is set to [ECO 30fps], Digital Zoom is not available (default setting).

Shutter button (Taking pictures)

1 Press the shutter button halfway (press lightly) to focus on the subject

- The aperture value and shutter speed are displayed. (If the aperture value and shutter speed are shown in red and flashing, you do not have the appropriate exposure, unless you are using the flash.)

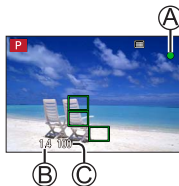

- (A) Focus display
(When focus is aligned: illuminated
When focus is not aligned: flashing)
- (B) Aperture value
- (C) Shutter speed

2 Press the shutter button fully (push the button all the way), and take the picture



- Pictures can be taken only when the image is correctly focused as long as the [Focus/Release Priority] is set to [FOCUS].

■ Estimated number of recordable pictures

1450*

- * (When [Aspect Ratio] is set to [3:2], [Quality] is set to [L], [Picture Size] is set to [L] (20M), and using a card of 16 GB)

■ Check the picture you have taken

- [Auto Review] displays the pictures you have taken after taking still pictures.
- Press the [▶] (Playback) button to display the picture. (→38)

Mode dial (Select the recording mode)

1 Set to the desired recording mode

- Rotate the mode dial slowly to select the desired mode.

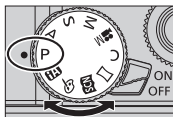

iA	iA Intelligent Auto Mode (→24)
	iA+ Intelligent Auto Plus Mode (→24)
P	Programme AE Mode Take pictures with automatic shutter speed and aperture value settings.
A	Aperture-Priority AE Mode Determine aperture, then take pictures.
S	Shutter-Priority AE Mode Determine shutter speed, then take pictures.
M	Manual Exposure Mode Determine aperture and shutter speed, then take pictures.
M	Creative Video Mode Determine aperture and shutter speed, then record motion pictures. • You cannot take still pictures.
C	Custom Mode Take pictures using pre-registered settings.
	Panorama Shot Mode Take panorama pictures.
SCN	Scene Guide Mode Take pictures that match the scene being recorded.
	Creative Control Mode Take pictures by selecting your preferred picture effect.

Function buttons

- [Fn1] to [Fn3] are buttons on the camera.
- [Fn4] to [Fn8] are touch icons. They are displayed by touching the [Fn] tab on the recording screen.
- You can assign frequently-used functions to particular buttons with [Fn Button Set] in [Custom] menu.

Cursor button

- This button is used to move the cursor on the menu screens and for other functions.
- In this manual, the button that is to be used is indicated by ▲ ▼ ◀ ▶.

You can perform the following operations while recording. (Some items or settings cannot be selected depending on the mode or display style the camera is in.)

[] (Exposure compensation) (▲)

- Corrects the exposure when there is a backlight or when the subject is too dark or too bright.

[WB] (White balance) (▶)

- Adjusts the colour depending on the light source to ensure natural colour.

[] (Drive mode) (▼)

- [Burst]*
 - Records a burst of still pictures while you press the shutter button fully.
- [4K PHOTO]* (→26)
- [Post Focus]* (→30)
- [Self Timer]*

* To cancel drive mode, select [] ([Single]) or [] ([Off]).

[MF] (Focus mode) (◀)

- [AF]
 - Focus is set automatically when the shutter button is pressed halfway.
- [AF👁] ([AF Macro])
 - You can take pictures of a subject as close as 3 cm (0.098 feet) from the lens by rotating the zoom lever upmost to Wide.
- [🔍] ([Macro Zoom])
 - Use this setting to get close to the subject and then further enlarge when taking the picture. You can take a picture with the digital zoom up to 3x while maintaining the distance to the subject for the extreme Wide position (3 cm (0.098 feet)).
- [MF]
 - Manual focus is convenient when you want to lock the focus to take pictures or when it is difficult to adjust focus using auto focus.

Adjusting the angle of the monitor

You can adjust the angle of the monitor.



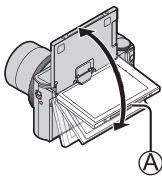

- **Be careful not to catch your finger, etc. in the monitor.**
 - **When rotating the angle of the monitor, be careful not to apply too much force. Doing so may cause damage or malfunction.**
- (Open and close with your finger on point (A).)**
- When not using this camera, close the monitor completely back to the original position.



Control ring/Aperture ring/Rear dial

You can perform frequently used operations and settings directly.

- You can adjust the aperture using the aperture ring. Gently turn the aperture ring until it snaps into place with an audible click. (The aperture can be set between [1.4] and [11].)
- Items that can be set by the control ring/rear dial vary depending on recording modes. Following are the pre-assigned settings.

Mode dial	Control ring* ¹	Rear dial
 A	Step Zoom	—
P	Step Zoom	Programme Shift
A	Step Zoom	—
S	Step Zoom	Shutter speed adjustment
M	Step Zoom	Shutter speed adjustment
 M	Step Zoom	Shutter speed adjustment* ²
 SCN	Step Zoom	Shutter speed adjustment* ³
	Picture effects change	—

*¹ When Manual Focus is set, the control ring is assigned to focus adjustment.

*² The operation is possible only when [Exposure Mode] is set to [S] or [M].

*³ The operation is possible only when the Scene Guide Mode is set to [Artistic Nightscape].

- You can change the assigned operation of the control ring and rear dial from [Ring/Dial Set] in the [Custom] menu. For details, refer to “Operating Instructions for advanced features (PDF format)”.

Touch screen (Touch operations)

Touch screen of this unit is capacitive. Touch the panel directly with your bare finger.

Touch

To touch and release the touch screen. Be sure to touch the centre of the desired icon.



Drag

To touch and slide your finger across the touch screen. This can also be used to forward or rewind a picture during playback, etc.



Pinch (spread/pinch)

On the touch screen, spread (pinch out) your 2 fingers to zoom in, and pinch (pinch in) your 2 fingers to zoom out.



Setting the menu

- 1 Press [MENU/SET] to bring up the menu
- 2 Press ▲ ▼ to select the menu item and press [MENU/SET]
- 3 Press ▲ ▼ to select the setting and press [MENU/SET]
 - The setting methods vary depending on the menu item.
- 4 Press [Q.MENU/↵] button repeatedly until the recording or playback screen reappears
 - During recording, the menu screen can also be exited by pressing the shutter button halfway.



■ Switching menu type



- ① Press ◀ after performing step 1 above
- ② Press ▲ ▼ to select a tab such as [🔧]
- ③ Press [MENU/SET]



■ Menu types (→41)

- [Rec]
- [Motion Picture]
- [Custom]
- [Setup]
- [Playback]

Taking pictures with automatic settings (Intelligent Auto Mode)

Recording mode:  

This mode is recommended for those who want to point and shoot as the camera optimises settings to match the subject and recording environment.

1 Set mode dial to





- The camera will switch to either the most recently used of Intelligent Auto Mode or Intelligent Auto Plus Mode.

2 Point the camera at the subject

- When the camera identifies the optimal scene, the icon for each scene turns blue for 2 seconds and then changes to the normal red indication.



■ Switching between Intelligent Auto Plus Mode and Intelligent Auto Mode

Select the  or  tab on the menu screen, press ► to select  or , and press [MENU/SET].

- If [DISP.] button is pressed, the description of the selected mode will be displayed.



[Self Shot]

Recording mode: 

You can easily take pictures of yourself while looking at the screen.

1 Rotate the monitor as shown in the figure

2 Touch the item

Settings:

- Ⓐ [Soft Skin] / Ⓑ [Filter Select] / Ⓒ [Slimming Mode] /
- Ⓓ [Shutter] / Ⓔ [Countdown] / [Shots]

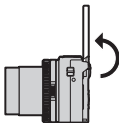

3 Touch the slide bar

- If you select the left edge of the slide bar (Ⓕ), it will be set to "Off".
- In the case of [Filter Select], [Shutter], or [Shots], select from the icons.

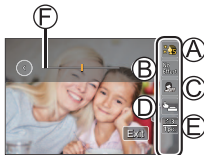

4 Touch [Exit]

5 Decide on your poses while looking at the monitor

6 Press the shutter button halfway to focus and then press it fully to take the picture

- Look at the lens when recording.
- Be careful not to look at the light from the flash and the AF Assist Lamp directly.



Recording 4K photos

Recording mode:

You can select the desired moment from a burst of 4K photos taken at 30 frames/second and save that moment as a picture of approx. 8 million pixels.

- To record pictures, use a UHS Speed Class 3 card.
- When recording, the angle of view becomes narrower.

1 Press [] button

2 Press to select the recording method and press [MENU/SET]





<p>[4K Burst]</p>	<p>For capturing the best shot of a fast-moving subject (e.g., sports, aeroplanes, trains) Burst recording is performed while the shutter button is pressed and held.</p> <p>(A) Press and hold (B) Recording is performed</p>	
<p>[4K Burst(S/S)] "S/S" is an abbreviation of "Start/Stop".</p>	<p>For capturing unpredictable photo opportunities (e.g., plants, animals, children) Burst recording starts when the shutter button is pressed and stops when pressed again.</p> <p>(C) Start (First) (D) Stop (Second) (E) Recording is performed</p>	
<p>[4K Pre-Burst]</p>	<p>For recording as needed whenever a photo opportunity arises (e.g. the moment when a ball is thrown) Burst recording is performed for approximately 1 second before and after the moment that the shutter button is pressed.</p> <p>(F) Approximately 1 second (G) Recording is performed</p>	

3 Record a 4K photo

- When you perform 4K burst photo recording, a 4K burst file will be saved in the MP4 format.
- When [Auto Review] is enabled, the picture selection screen will be displayed automatically.
- You can compare multiple frames captured in a 4K burst file, overlay the bright areas, and combine them into one picture. ([Light Composition]) (→39)

■ To cancel the 4K Photo functions

In step 2, select [].

- If the surrounding temperature is high or 4K photos are recorded continuously, [] may be displayed and recording may be stopped halfway through. Wait until the camera cools down.
- **When [] ([4K Pre-Burst]) is set, the battery drains faster and the camera temperature rises. (to protect itself, the camera may switch to [] ([4K Burst]))**
Select [] ([4K Pre-Burst]) only when recording.
- The continuous recording time is the same as when [Rec Format] is set to [MP4], and [Rec Quality] is set to [4K/100M/30p], [4K/100M/25p], or [4K/100M/24p]. (→35)

Saving a picture from a 4K burst file

- To select and save a picture, perform the following operations.
- To bulk save the pictures (→29).

1 Select a picture with the [▲] on the playback screen, and press ▲

- In the case of recording with [4K] ([4K Pre-Burst]), proceed to the step 3.



2 Drag the slide bar to perform rough scene selection



3 Drag to select the frame you want to save as a picture

- Touch [◀]/[▶] to display the previous or next set of frames (45) in slide view.



4 Touch [📷] to save the picture

- The picture will be saved in JPEG format.
- For details, refer to “Operating Instructions for advanced features (PDF format)” or “Quick Guide for 4K Photo (supplied)”.

■ [4K PHOTO Bulk Saving]

You can bulk save 5 seconds' worth of 4K recording from a 4K burst file.

- If [Auto Review] is set, the slide view screen appears automatically. Press the shutter button halfway to display the recording screen, and then perform the following operations.

MENU →  **[Playback]** → **[4K PHOTO Bulk Saving]**

- ① Use ◀▶ to select the 4K burst files and press [MENU/SET]
 - If the burst time is 5 seconds or less, all the frames can be saved as a picture.
- ② Select the first frame to be bulk saved as a picture
 - The selection method is the same as the operation to choose the frame you want to save as a picture from a 4K burst file.
 - The picture will be saved in JPEG format as a single burst picture group.

[Post Focus] / [Focus Stacking]

Recording mode:          

You can record bursts of photos with the same quality as a 4K photo while automatically changing the focus point. After recording, you can select a point on the screen to save a picture with that point as the focus point.

You can combine multiple pictures, each with a different focus, to increase the focus range. ([Focus Stacking])

- We recommend using a tripod to perform [Focus Stacking].
- To record pictures, use a UHS Speed Class 3 card.
- During recording, the angle of view will be narrower.

1 Press button

2 Press ◀▶ to select [ON] and press [MENU/SET]

3 Determine the composition and press the shutter button halfway

- Auto Focus activates and automatically detects the focus point on the screen.
- If there is no focus point on the screen, the Focus indicator (Ⓐ) blinks and you cannot record.



From halfway pressing the shutter button to completion of recording

- Do not change the distance to subject or the composition.

4 Press the shutter button fully to start recording



- The focus point changes automatically while recording. When the recording progress bar (Ⓑ) disappears, recording automatically ends.
- A motion picture will be recorded in MP4 format. (No audio is recorded.)
- If Auto Review is set, a screen will automatically appear that lets you select the focus point. (→31)

- If the surrounding temperature is high or [Post Focus] recording is performed continuously, [△] may be displayed and recording may be stopped halfway through. Wait until the camera cools down.

Select the focus point and save the picture ([Post Focus])

- 1 On the playback screen, select the image with the [△] icon and press ▲



- 2 Touch the focus point

- If there are no pictures with the focus on the selected point, a red frame will be displayed, and pictures cannot be saved.
- The edge of the screen cannot be selected.
- Press [Fn1] to switch to the [Focus Stacking] operations screen. (→32)
- To highlight in-focus portion with colour, touch [PEAK].
- To enlarge the display, touch [Q].
- You can make fine adjustments to the focus by dragging the slide bar during enlarged display.

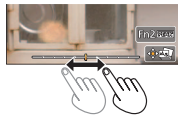

- 3 Touch [⊞] to save the picture

- The picture will be saved in JPEG format.

- You cannot choose and save the picture from a TV screen even if the camera is connected to a TV through an HDMI micro cable.

Combine multiple pictures to increase the focus range ([Focus Stacking])

You can combine multiple pictures from pictures recorded using [Post Focus] to create a single picture with an expanded focus range.

- 1 Touch  on screen in step 2 of “Select the focus point and save the picture ([Post Focus])” (→31)
- 2 Choose a stacking method and touch it

[Auto Merging]	Automatically select photos suitable for stacking and combine them into one picture. <ul style="list-style-type: none"> • Choose by giving preference to near-focus pictures. • Perform the focus stacking and save the picture.
[Range Merging]	Combine the pictures with the selected focus position into one picture.

- 3 (When selecting [Range Merging])
Touch the focus point

- Select positions at two or more points.
- Focus positions between the two points are selected and the range of the in-focus portion is displayed in green.
- The ranges that are greyed out are positions that cannot be selected, or that would produce an unnatural result if selected for focus stacking.

- Touch a position again to deselect it.
- If you drag the screen you can then continue to select positions.

- 4 Touch  to combine and save the picture
 - The picture will be saved in JPEG format.

- Only pictures taken using [Post Focus] are eligible for [Focus Stacking].

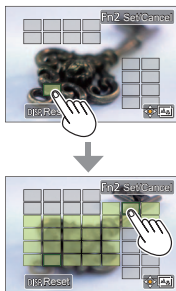

Taking Pictures While Adjusting a Setting Automatically (Bracket Recording)

Recording mode:

You can take multiple pictures while automatically adjusting a setting by pressing the shutter button.

1 Set the menu (→23)

MENU → **[Rec]** → **[Bracket]** → **[Bracket Type]**

(Exposure Bracket)	Press the shutter button to perform recording while adjusting the exposure.
(Aperture Bracket)	Press the shutter button to perform recording while adjusting the aperture.
FOCUS (Focus Bracket)	Press the shutter button to perform recording while adjusting the focus position.
(White Balance Bracket)	Press the shutter button once to take three pictures with different white balance settings automatically.

2 Press ▼ to select [More settings] and then press [MENU/SET]

- If is set, rotate the rear dial to set the adjustment range.
- Press the shutter button halfway to exit the menu.

3 Focus on the subject and take a picture

■ To cancel [Bracket]

Select [OFF] in step 1.

Recording Motion Picture/4K Motion Picture

Recording mode: 

You can record full high-definition quality images that comply with the AVCHD standard, as well as motion pictures or 4K motion pictures recorded in MP4.

1 Press the motion picture button to start recording

- (A) Recording (red)
- (B) Elapsed recording time
- (C) Remaining recording time

- Recording of motion picture appropriate for each motion picture mode is possible.
- Immediately release the motion picture button after pressing it.
- If you press the shutter button down fully, you can take still pictures while recording motion pictures.

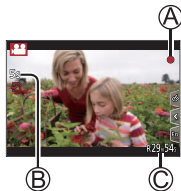

2 Press the motion picture button again to end recording

- If the surrounding temperature is high, or a motion picture is recorded continuously, [] is displayed and recording may be stopped halfway through. Wait until the camera cools down.
- **With recording in a quiet environment, the sound of aperture, focus and other actions may be recorded in motion pictures. This is not a malfunction.**
- To record 4K motion pictures, use a UHS Speed Class 3 card.
- When you record 4K motion pictures, the angle of view will be narrower than motion pictures of other sizes.
- To ensure highly accurate focus, 4K motion pictures are recorded at reduced Auto Focus speeds. It may be difficult to focus on the subject with Auto Focus, but this is not a malfunction.

■ Setting the format, picture size and recording frame rate

MENU →  **[Motion Picture]** → **[Rec Format]**

Settings: **[AVCHD]** / **[MP4]**

MENU →  **[Motion Picture]** → **[Rec Quality]**

When **[AVCHD]** is selected:

[FHD/28M/50p]*1 / **[FHD/17M/50i]** / **[FHD/24M/25p]** / **[FHD/24M/24p]**

- **[AVCHD]** motion pictures:

Recording stops when the continuous recording time exceeds 29 minutes and 59 seconds.

Files are split into smaller motion picture files for recording when the file size exceeds 4 GB.

When **[MP4]** is selected:

[4K/100M/30p]*2 / **[4K/100M/25p]*2** / **[4K/100M/24p]*2** / **[FHD/28M/60p]** / **[FHD/28M/50p]** / **[FHD/20M/30p]** / **[FHD/20M/25p]** / **[HD/10M/30p]** / **[HD/10M/25p]**

- Motion pictures with their file size set to **[FHD]** or **[HD]** in **[MP4]**:

Recording stops when the continuous recording time exceeds 29 minutes and 59 seconds.

Files are split into smaller motion picture files for recording and playback when the file size exceeds 4 GB. (You can continue to record motion pictures without interruption.)

- Motion pictures with their file size set to **[4K]** in **[MP4]**:

Recording stops when the continuous recording time exceeds 15 minutes.

When using an SDHC memory card, files are split into smaller motion picture files for recording and playback if the file size exceeds 4 GB. (You can continue to record motion pictures without interruption.)

If using an SDXC Memory Card, you can record a motion picture in a single file even if the size is greater than 4 GB.

*1 AVCHD Progressive

*2 4K motion pictures

[4K Live Cropping]

Recording mode: 

By cropping your motion picture down from the 4K angle of view to Full High Definition, you can record a motion picture that pans and zooms in/out while leaving the camera in a fixed position.

- Hold the camera firmly in place while recording.
- A motion picture will be recorded at [FHD/20M/25p] under [MP4].



Pan

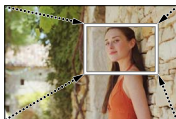

Zoom in

- When you want to zoom in/out, set different angles of view for the cropping start and end frames. For example, to zoom in, set a larger angle of view for the start frame and a smaller angle of view for the end frame.

1 Set mode dial to [M]

2 Set the menu (→23)

MENU →  **[Motion Picture]** → **[4K Live Cropping]**

Settings: [40SEC] / [20SEC] / [OFF]

- The angle of view narrows.

3 Set the crop start frame

4 Repeat step 3, and then set the crop end frame

5 Press the motion picture button (or the shutter button) to start recording

- (A) Elapsed recording time
- (B) Set operating time

- Immediately release the motion picture button (or the shutter button) after pressing it.
- When the set operating time has elapsed, recording automatically ends. To end recording midway, press the motion picture button (or the shutter button) again.

■ Changing the position and size of a crop frame

Press [Fn1] button while the recording screen is displayed, and perform steps 3 and 4.

- Focus is adjusted and fixed in the crop start frame.
- [Continuous AF] is set to [OFF].



Viewing your pictures

1 Press [▶] (Playback) button

- When [Lens Retraction] is set to [ON], the lens barrel is retracted after approx. 15 seconds as the camera is switched to the playback screen from the recording screen.

2 Press ◀▶ to select a picture to be displayed

■ Viewing motion pictures

This unit was designed to play motion pictures using the AVCHD and MP4 formats.

- Motion pictures are displayed with the motion picture icon ([▶]).

① Press ▲ to start playback

- If you press [MENU/SET] during a pause, you can create a picture from a motion picture.



■ Sending pictures to the WEB services

If you press ▼ while a single picture is being displayed, you can send the picture to the WEB service quickly.

■ Deleting pictures

Deleted pictures cannot be recovered.

① Press [⏏] button to delete displayed picture

② Use ▲ to select [Delete Single] and press [MENU/SET]

■ Ending Playback

Press [▶] (Playback) button again or press the motion picture button.

The playback can also be ended by pressing the shutter button halfway.

[Light Composition]

Select multiple frames from 4K burst files that you wish to combine. Parts of the image that are brighter than the preceding frame will be superimposed on the preceding frame to combine the frames into one picture.



- When using [Light Composition], it is recommended to use a tripod or use a smartphone instead of the shutter and do remote recording (→47) to control camera shaking.

MENU → **[Playback]** → **[Light Composition]**

1 Use ◀▶ to select the 4K burst files and press [MENU/SET]

2 Choose the combining method and press [MENU/SET]

■ When [Composite Merging] is selected

Select the frames you wish to combine, and then camera superimposes brighter parts of the image.

① Select the frames

- Images displayed cannot be enlarged or shrunk or shown as in slide view.
- [] in touch operation becomes [OK].



② Press [MENU/SET]

The selected frames are remembered, and the display goes to the preview screen.

Use ▲ ▼ to select items and press [MENU/SET] to perform the following operations.

- [Next]: Lets you select more frames for combining. Goes back to step ①.
- [Reselect]: Discards the frame selected immediately before and lets you select a different image.
- [Save]: Ends frame selection.

③ Repeat steps ① - ② to select more frames to combine

- You can select up to 40 frames.

④ Press ▼ to select [Save] and press [MENU/SET]

■ **When [Range Merging] is selected**

Select the first and last frames, and the brighter parts of frames within that range will be superimposed.

① Select the frame of the first picture and then press [MENU/SET]

The selection method is the same as in step ① when selecting [Composite Merging].

② Select the frame of the last picture and then press [MENU/SET]

3 Select [Yes] at the confirmation screen and press [MENU/SET]

The combined picture is displayed.

- The picture will be saved in JPEG format.

Menu list

- The [Photo Style], [Filter Settings], [Sensitivity], [AF Mode], [AFS/AFF/AFC], [Metering Mode], [Highlight Shadow], [i.Dynamic], [i.Resolution], [Diffraction Compensation], [i.Zoom], [Digital Zoom], and [Stabilizer] menu items are common for both [Rec] and [Motion Picture] menus. If a setting in one menu is changed, the setting with the same name in other menu will also be changed automatically.

[Rec]

[Photo Style]	[Highlight Shadow]	[ISO Limit Set]
[Filter Settings]	[i.Dynamic]	[ISO Increments]
[Aspect Ratio]	[i.Resolution]	[Extended ISO]
[Picture Size]	[iHandheld Night Shot]	[Long Shtr NR]
[Quality]	[iHDR]	[Diffraction Compensation]
[Sensitivity]	[HDR]	[i.Zoom]
[AF Mode]	[Multi Exp.]	[Digital Zoom]
[AFS/AFF/AFC]	[Time Lapse Shot]	[Color Space]
[Metering Mode]	[Stop Motion Animation]	[Stabilizer]
[Burst Rate]	[Panorama Settings]	[Face Recog.]
[4K PHOTO]	[Shutter Type]	[Profile Setup]
[Bracket]	[Flash]	
[Self Timer]	[Red-Eye Removal]	

 [Motion Picture]

[4K Live Cropping]

[Exposure Mode]

[Flkr Decrease]

[Snap Movie]

[High Speed Video]

[Silent Operation]

[Rec Format]

[Continuous AF]

[Wind Noise Canceller]

[Rec Quality]

[Level Shot]

 [Custom]

[Cust.Set Mem.]

[MF Assist Display]

[Remaining Disp.]

[Silent Mode]

[MF Guide]

[Auto Review]

[AF/AE Lock]

[Peaking]

[Fn Button Set]

[AF/AE Lock Hold]

[Histogram]

[Zoom lever]

[Shutter AF]

[Guide Line]

[Lens Position Resume]

[Half Press Release]

[Center Marker]

[Lens Retraction]

[Quick AF]

[Highlight]

[Q.MENU]

[Pinpoint AF Time]

[Zebra Pattern]

[Ring/Dial Set]

[Pinpoint AF Display]

[Monochrome Live View]

[Self Shot]

[AF Assist Lamp]

[Constant Preview]

[Touch Settings]

[Focus/Release Priority]

[Expo.Meter]

[Touch Scroll]

[AF+MF]

[Dial Guide]

[Menu Guide]

[MF Assist]

[Rec Area]

[Setup]

[Online Manual]	[Economy]	[Exposure Comp. Reset]
[Clock Set]	[USB Mode]	[Self Timer Auto Off]
[World Time]	[TV Connection]	[No.Reset]
[Travel Date]	[Menu Resume]	[Reset]
[Wi-Fi]	[Menu Background]	[Reset Wi-Fi Settings]
[Beep]	[Menu Information]	[Level Gauge Adjust.]
[Live View Mode]	[Language]	[Demo Mode]
[Monitor Display]	[Version Disp.]	[Format]
[Monitor Luminance]		

[Playback]

[Slide Show]	[Title Edit]	[Rotate]
[Playback Mode]	[Text Stamp]	[Rotate Disp.]
[Location Logging]	[Video Divide]	[Favorite]
[RAW Processing]	[Time Lapse Video]	[Print Set]
[4K PHOTO Bulk Saving]	[Stop Motion Video]	[Protect]
[Light Composition]	[Resize]	[Face Rec Edit]
[Clear Retouch]	[Cropping]	[Picture Sort]

What you can do with the Wi-Fi[®] function

- **Operating the camera by connecting it to a smartphone**
 - Taking pictures via a smartphone (→47)
 - Playing back pictures in the camera on a smartphone (→47)
 - Saving pictures in the camera to a smartphone
 - Sending pictures in the camera to social networking services
 - Adding location information to pictures in the camera from a smartphone
 - Combining motion pictures recorded with Snap Movie according to your preference on a smartphone
 - **Displaying still pictures on a TV**
 - **Wireless printing**
 - **Sending pictures to AV device**
 - **Sending pictures to a PC**
 - **Using WEB services**
-
- This manual uses the term “smartphone” for both smartphones and tablets unless it is necessary to distinguish between them.
 - The camera cannot be used to connect to a public wireless LAN connection.

Operating the camera by connecting it to a smartphone

Installing the smartphone app “Panasonic Image App”

The “Image App” is an application provided by Panasonic.

Supported OS	Android™: Android 4.0 or later iOS: iOS 7.0 or later
Installation procedure	<ol style="list-style-type: none"> ① Connect your device to a network ② (Android) Select “Google Play™ Store” (iOS) Select “App Store” ③ Enter “Panasonic Image App” or “LUMIX” to search for the app ④ Select “Panasonic Image App” and install it



- Use the latest version.
- Supported OS versions as of October 2016. Supported OS versions may be changed without prior notice.
- The service may not be able to be used properly depending on the type of smartphone being used.
For the latest information on the “Image App”, refer to the support site below.
<http://panasonic.jp/support/global/cs/dsc/> (This site is available in English only.)
- When downloading the app on a mobile network, high packet communication fees may be incurred depending on the details of your contract.
- For details about the operating procedure, etc., refer to [Help] in the “Image App” menu.
- If you connect the camera and smartphone over a Wi-Fi connection and run “Image App”, [Help] may not be displayed in the “Image App” menu for some smartphones. In such a case, disconnect the Wi-Fi connection with the camera, connect the camera to a cellular data line such as 3G and LTE, or the Internet to display [Help] in the “Image App” menu.
- Some of the screens and information provided in this document may be different depending on the supported operating system and “Image App” version.

Connecting to a smartphone

You can easily establish a Wi-Fi connection on this unit without entering a password on your smartphone.

(On the camera)

MENU →  **[Setup]** → **[Wi-Fi]** → **[Wi-Fi Function]** → **[New Connection]**
→ **[Remote Shooting & View]**

- The information required for directly connecting your smartphone to this unit (SSID (A)) is displayed.
- You can also display the information by pressing the function button that [Wi-Fi] function is assigned. (At the time of purchase, [Wi-Fi] is assigned to [Fn4] button in recording mode, and [Fn1] in playback mode.)



(On your smartphone)

- 1 Turn on the Wi-Fi function in the setting menu
- 2 Select the SSID displayed on the screen of the camera
- 3 Start “Image App” (→45)

- When the connection confirmation screen appears on the camera, select [Yes] and press [MENU/SET]. (Only when making a connection for the first time.)

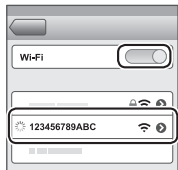

[Wi-Fi Password] is set to [OFF] at the time of purchase. When you start a Wi-Fi connection, be sure to verify that the device displayed on the camera's connection confirmation screen is really the device you want to connect to. Even if the wrong device is displayed, you will still be connected to it if you select “Yes”. If there seem to be other Wi-Fi enabled devices in the vicinity, we recommend that you set [Wi-Fi Password] to [ON]. For details, refer to “Operating Instructions for advanced features (PDF format)”.

Closing the connection

1 Set the camera to Recording Mode

- Press the shutter button halfway to return to recording mode.

2 Select the camera's menu items to terminate the Wi-Fi connection

MENU →  [Setup] → [Wi-Fi] → [Wi-Fi Function]
→ [Yes]

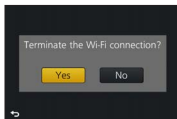

3 On the smartphone, close "Image App"

- For details on how to close the application, refer to the operating instructions of your device.

Taking pictures via a smartphone (remote recording)

1 Connect to a smartphone (→46)

2 Operate the smartphone

① Select []

② Take pictures

- The recorded images are saved in the camera.
- Some settings are not available.



Playing back pictures in the camera on a smartphone

1 Connect to a smartphone (→46)

2 Operate the smartphone

① Select []

- When the picture is touched, it is played back at a larger size.



Downloading software

Still/motion pictures can be copied from the camera to your computer by connecting the two together. If you wish to play back or edit pictures on a PC, download software from the supplier's website and install it on your PC.

- To download the software, your PC must be connected to the Internet.
- It may take time to download the software in some communication environments.

PHOTOfunSTUDIO 9.9 PE

You can capture still pictures or motion pictures to your PC, or organise captured pictures by categorising by recording date, model name of the digital camera used to record, etc. You can also correct still pictures, edit motion pictures, or write to DVD.

- Check the website below to download/install the software.

The software is available for download until the end of October 2021.

http://panasonic.jp/support/global/cs/soft/download/d_pfs99pe.html

- **Operating environment**

Supported OS	Windows® 10 (32-bit/64-bit)	
	Windows® 8.1 (32-bit/64-bit)	
	Windows® 8 (32-bit/64-bit)	
	Windows® 7 (32-bit/64-bit) SP1	
CPU	Windows® 10	Pentium® 4 2.8 GHz or higher
	Windows® 8.1	
	Windows® 8	
	Windows® 7	
Display	1024×768 pixels or more (1920×1080 pixels or more recommended)	
RAM	Windows® 10	1 GB or more (32-bit) / 2 GB or more (64-bit)
	Windows® 8.1	
	Windows® 8	
	Windows® 7	
Free hard disk space	450 MB or more for installing software	

- To edit 4K motion pictures, you need the 64-bit versions of Windows 10, Windows 8.1, Windows 8, or Windows 7.
- "PHOTOfunSTUDIO" is not compatible with Mac.
- Refer to the operating instructions of "PHOTOfunSTUDIO" (PDF) for further information about the operating environment.

SILKYPIX Developer Studio SE

This software develops and edits RAW file pictures. Edited pictures can be saved in a file format such as JPEG or TIFF that can be displayed on a PC, etc.

- Check the website below to download/install the software.
<http://www.isl.co.jp/SILKYPIX/english/p/>
- Supported OS: Windows® 10 / 8.1 / 8 / 7
Mac® OS X v10.6 - v10.11
- For details on the operating environment and how to use the SILKYPIX Developer Studio SE, refer to the “Help” or the Ichikawa Soft Laboratory’s support website.

LoiLoScope 30 day full trial version

Motion pictures can be edited easily.

- Check the website below to download/install the software.
<http://loilo.tv/product/20>
- Supported OS: Windows® 10 / 8.1 / 8 / 7
- For more information on how to use LoiLoScope and its operating environment, read the LoiLoScope manual available for download at the website.
- “LoiLoScope” is not compatible with Mac.

Reading the Operating Instructions (PDF format)

More detailed operating instructions are available in “Operating Instructions for advanced features (PDF format)”. To read it, download it from the website.

<http://panasonic.jp/support/dsc/oi/index.html?model=DMC-LX15&dest=EB>





























- Click the desired language.

■ Confirming URLs and QR codes with the camera

MENU →  **[Setup]** → **[Online Manual]**

Settings: [URL display] / [QR Code display]

- The URL or QR code will be displayed on the camera monitor.
- You will need Adobe Reader to browse or print the Operating Instructions (PDF format). You can download and install a version of Adobe Reader that you can use with your OS from the following website. (As of October 2016)
<http://www.adobe.com/products/acrobat/readstep2.html>

2	 [Quality]	3	Name*2
	100fps [High Speed Video]		Travel elapsed days*3
	AFS [AFS/AFF/AFC]/MF		Age in years/months*2
	 BKT AFS Focus Bracket		Location*3
	 AF Mode		Current date/time*3
	 [Pull Focus]		Travel destination setting*3: 
	 [Face Recog.]		Exposure meter
	AFL AF Lock		Zoom (→16)
	 Burst	4	 AF area
	 [4K PHOTO] (→26)		+ Spot metering target
	 [Post Focus] (→30)		+ [Center Marker]
	 [Self Timer]		 [Self Timer]
	 Remaining battery		 [Silent Mode]
	 AF  Macro recording (→20)		AEL AE Lock
	 [Level Shot]		 [Metering Mode]
	 [Stabilizer]		P  Programme Shift
	 Jitter alert		1.4 Aperture value
	 Recording state (Flashes red.) (→34)/ Focus (Lights green.) (→17)		^{BKT} 1.4 Aperture Bracket
	 Focus (Under low illumination)		60 Shutter speed
	 Focus (Starlight AF)		Exposure compensation value
	 Wi-Fi connection status		^{BKT}  ± 0 Exposure Bracket
	 Histogram		Brightness (exposure)
			Manual Exposure Assist
			^{ISO} 200 ISO sensitivity

5

	[Dial Guide]
BKT AWB+	White Balance Bracket
	White Balance Fine Adjustment
	White Balance
	Colouring
98	Number of recordable pictures
RXXmXXs	Available recording time*1

6

Touch tab

	Touch zoom
	Touch Shutter
	[Touch AE]
	[Peaking]
	[Self Shot] (→25)

	Function buttons (→19)
	Colouring
	Defocus control function
	Brightness (exposure)
	Type of defocus ([Miniature Effect])
	[One Point Color]
	[Sunshine]
	Picture effect (Filter) adjustment display
	Picture effects ON or OFF
	Picture effects (Filter)
	Shutter speed
	ISO sensitivity

- *1 [m] and [s] indicate "minute" and "second".
 - *2 This is displayed for about 5 seconds when the camera is turned on if the [Profile Setup] setting is set.
 - *3 This is displayed for about 5 seconds when the camera is turned on, after setting the clock and after switching from Playback Mode to Recording mode.
- The information displayed, such as histograms, magnifications, and numeric values, are only for the purpose of reference.

Q&A Troubleshooting

- Performing [Reset] in the [Setup] menu may resolve the issue.
- Further information is provided in the “Operating Instructions for advanced features (PDF format)”. Check it together with the information in this section.

The charging lamp blinks.

- Charging is being performed in a place with extremely high or low temperature.
→ **Reconnect the USB connection cable (supplied) and retry charging in a place where ambient temperature is 10 °C to 30 °C (50 °F to 86 °F) (temperature conditions also apply to the battery itself).**
- Charging is not possible if the power supply capacity of the computer is low.

Sometimes focus adjustment with auto focus mode is difficult while recording 4K motion pictures.

- This may occur when taking a picture by reducing the auto focus speed in order to adjust the focus at high precision. This is not a malfunction.

**It cannot connect to the wireless LAN. Radio waves get disconnected.
Wireless access point is not displayed.**

General tips for using a Wi-Fi connection

- Use within the communication range of the wireless LAN network.
- If any device, such as microwave oven, cordless phone, etc., that uses 2.4 GHz frequency are used nearby this unit simultaneously, radio waves may get interrupted.
→ Use them sufficiently away from the device.
- When the battery indicator is flashing red, the connection with other equipment may not start or the connection may be disrupted. (A message such as [Communication error] is displayed.)
- When this unit is placed on a metal table or shelf, the connection may not be established easily because the camera is affected by radio waves. Use the camera away from metal surfaces.

About a wireless access point

- Check if the wireless access point to connect is in operating state.
- Check the radio wave condition of the wireless access point.
→ Perform the connection closer to the wireless access point.
→ Move the location or change the angle of the wireless access point.
- It may not display even if the radio waves exist depending on the setting of the wireless access point.
→ Turn off the wireless access point and then turn it back on.
- If the network SSID of the wireless access point is set not to broadcast, it may not be detected.
→ Enter and set the network SSID. Alternatively, set the network SSID of the wireless access point to broadcast.

Specifications

Digital Camera: Information for your safety

Power Source	DC 8.4 V (≡ 8.4 V)
Power	1.9 W (When recording)
Consumption	1.6 W (When playing back)

Camera effective pixels	20,100,000 pixels
Image sensor	1" MOS sensor, total pixel number 20,900,000 pixels Primary colour filter
Lens	Optical 3x zoom f=8.8 mm to 26.4 mm (35 mm film camera equivalent: 24 mm to 72 mm) Max. Wide: F1.4 to F11 Max. Tele: F2.8 to F11
Image Stabiliser	Optical method
Focus range	AF: 30 cm (0.98 feet) (Max. Wide)/ 30 cm (0.98 feet) (Max. Tele) to ∞ AF Macro/MF/Intelligent Auto/Motion picture: 3 cm (0.098 feet) (Max. Wide)/ 30 cm (0.98 feet) (Max. Tele) to ∞
Shutter system	Electronic shutter + Mechanical shutter
Minimum Illumination	Approx. 3 lx (when i-Low light is used, the shutter speed is 1/25th of a second)

Shutter speed	Still picture: T (Time) (Max. approx. 120 seconds), 60 seconds to 1/4000th of a second (When the mechanical shutter is used), 1 second to 1/16000th of a second (When the electronic shutter is used) Motion picture: 1/2 second to 1/16000th of a second (When [M] is selected in Creative Video Mode, MF), 1/25th of a second to 1/16000th of a second (Other than the above)
Exposure (AE)	Programme AE (P)/Aperture-priority AE (A)/ Shutter-priority AE (S)/Manual exposure (M)/AUTO Exposure Compensation (1/3 EV steps, -5 EV to +5 EV)
[Metering Mode]	Multiple/Centre weighted/Spot
Monitor	3.0" TFT LCD (3:2) (Approx. 1,040,000 dots) (field of view ratio about 100%) Touch screen
Flash	Built-in pop up flash AUTO, AUTO/Red-Eye Reduction, Forced ON, Forced ON/Red-Eye Reduction, Slow Sync., Slow Sync./Red-Eye Reduction, Forced OFF
Microphones	Stereo
Speaker	Monaural

Recording media	SD Memory Card/SDHC Memory Card*/ SDXC Memory Card* *UHS-I UHS Speed Class 3
Recording file format	
Still picture	RAW/JPEG (based on Design rule for Camera File system, based on Exif 2.3 standard/DPOF corresponding)
Motion picture	AVCHD Progressive/AVCHD/MP4
Audio compression format	AVCHD: Dolby® Digital (2 ch) MP4: AAC (2 ch)
Interface	
Digital	USB 2.0 (High Speed) Data from the PC cannot be written to the camera using the USB connection cable.
Terminal	
[HDMI]	Micro HDMI Type D
[USB/CHARGE]	USB 2.0 micro-B
Dimensions	Approx. 105.5 mm (W) x 60 mm (H) x 42 mm (D) [4.15" (W) x 2.36" (H) x 1.65" (D)] (excluding the projection part)
Mass	With card and battery: Approx. 310 g (0.68 lb) Excluding card and battery: Approx. 280 g (0.62 lb)
Operating temperature	0 °C to 40 °C (32 °F to 104 °F)
Operating humidity	10%RH to 80%RH

■ Wi-Fi

Compliance standard	IEEE 802.11b/g/n (standard wireless LAN protocol)
Frequency range used (central frequency)	2412 MHz to 2462 MHz (1 to 11 ch)
Encryption method	Wi-Fi compliant WPA™/WPA2™
Access method	Infrastructure mode

■ AC adaptor

(Panasonic SAE0012F): Information for your safety

Input:	110 V – 240 V ~ 50/60 Hz 0.2 A
Output:	5 V === 1.0 A

■ Battery pack (lithium-ion)

(Panasonic DMW-BLH7E): Information for your safety

Voltage/capacity:	7.2 V/680 mAh
--------------------------	---------------

The symbols on this product (including the accessories) represent the following:

~	AC
===	DC
	Class II equipment (The construction of the product is double-insulated.)

Specifications are subject to change without notice.

Digital Camera Accessory System

Battery pack DMW-BLH7	The battery pack can be charged from the camera using the AC adaptor (supplied).
AC adaptor DMW-AC10	By using the AC adaptor (DMW-AC10: optional) and DC coupler (DMW-DCC15A: optional), you can record and play back without worrying about the remaining battery charge. <ul style="list-style-type: none"> • The optional DC coupler (DMW-DCC15) cannot be used. The AC adaptor (optional) can only be used with the designated Panasonic DC coupler (optional). The AC adaptor (optional) cannot be used by itself. • When using an AC adaptor (optional), use the AC mains lead supplied with the AC adaptor.
DC coupler DMW-DCC15A	

- Part numbers are as of October 2016. These may be subject to change.
- Some optional accessories may not be available in some countries.

Sales and Support Information

Customer Communications Centre

- For customers within the U.K.: 0344 844 3899
- For customers within Ireland: 01 289 8333
- Monday - Friday 9:00am - 5:00pm (Excluding public holidays).
- For further support on your product, please visit our website:
www.panasonic.co.uk

Direct Sales at Panasonic U.K.

- Order accessory and consumable items for your product with ease and confidence by phoning our Customer Communications Centre Monday - Friday 9:00am - 5:00pm (Excluding public holidays).
- Or go on line through our Internet Accessory ordering application at www.pas-europe.com.
- Most major credit and debit cards accepted.
- All enquiries transactions and distribution facilities are provided directly by Panasonic U.K.
- It couldn't be simpler!
- Also available through our Internet is direct shopping for a wide range of finished products. Take a browse on our website for further details.

- SDXC Logo is a trademark of SD-3C, LLC.
- The terms HDMI and HDMI High-Definition Multimedia Interface, and the HDMI Logo are trademarks or registered trademarks of HDMI Licensing, LLC in the United States and other countries.
- HDAVI Control™ is a trademark of Panasonic Corporation.
- “AVCHD”, “AVCHD Progressive” and the “AVCHD Progressive” logo are trademarks of Panasonic Corporation and Sony Corporation.
- Manufactured under license from Dolby Laboratories. Dolby and the double-D symbol are trademarks of Dolby Laboratories.
- Pentium is a trademark of Intel Corporation in the U.S. and/or other countries.
- Windows is either registered trademark or trademark of Microsoft Corporation in the United States and/or other countries.
- iMovie, Mac and Mac OS are trademarks of Apple Inc., registered in the U.S. and other countries.
- iPad, iPhone, iPod, and iPod touch are trademarks of Apple Inc., registered in the U.S. and other countries.
- App Store is a service mark of Apple Inc.
- Android and Google Play are trademarks or registered trademarks of Google Inc.
- The Wi-Fi CERTIFIED™ Logo is a certification mark of Wi-Fi Alliance®.
- The Wi-Fi Protected Setup™ Identifier mark is a certification mark of Wi-Fi Alliance®.
- “Wi-Fi®” and “Wi-Fi Direct®” are registered trademarks of Wi-Fi Alliance®.
- “Wi-Fi Protected Setup™”, “WPA™”, and “WPA2™” are trademarks of Wi-Fi Alliance®.
- DLNA, the DLNA Logo and DLNA CERTIFIED are trademarks, service marks, or certification marks of the Digital Living Network Alliance.
- QR Code is a registered trademark of DENSO WAVE INCORPORATED.
- This product uses “DynaFont” from DynaComware Corporation. DynaFont is a registered trademark of DynaComware Taiwan Inc.
- Other names, company names, and product names mentioned in these instructions are trademarks or registered trademarks of the companies concerned.



WiFi
CERTIFIED



PictBridge



EU



Manufactured by: Panasonic Corporation
Kadoma, Osaka, Japan
Importer for Europe: Panasonic Marketing Europe GmbH
Panasonic Testing Centre
Winsbergring 15, 22525 Hamburg, Germany

Panasonic Corporation

Web Site: <http://www.panasonic.com>

© Panasonic Corporation 2016