

MICROWAVE OVEN

MODEL: EG8525X-Y

SERVICING MANUAL

PRECAUTIONS TO AVOID POSSIBLE EXPOSURE TO EXCESSIVE MICROWAVE ENERGY

- A. Do not attempt to operate this oven with the door open since open-door operation can result in harmful exposure to microwave energy. It is important not to defeat or tamper with the safety interlocks.
- B. Do not place any object between oven front face and the door or allow soil or cleaner residue to accumulate on sealing surfaces.
- C. Do not operate the oven if it is damaged. It is particularly important that the oven door close properly and that there is no damage to the (1) Door (bent), (2) hinges and latches (broken or loosened), (3) door seals and sealing surfaces.
- D. The oven should not be adjusted or repaired by anyone except properly qualified service personnel.

SAVE THESE INSTRUCTIONS

IMPORTANT SAFETY INSTRUCTIONS

When using electrical appliances, basic safety precautions should be followed, including the following:

WARNING—To reduce the risk of burns, electrical shock, fire, injury to persons or exposure to excessive microwave energy:

1. READ ALL THE INSTRUCTIONS BEFORE USING THE APPLIANCE.
2. Read and follow the specific "Precautions to avoid possible exposure to excessive microwave energy" found above.
3. This appliance must be grounded and properly polarized. Connect only to a properly grounded and polarized outlet. See "Grounding Instructions" on page 3.
4. Install or locate this appliance only in accordance with the installation instructions described in this manual.
5. Some products such as whole eggs and sealed containers, such as closed glass jars, may explode and should not be heated in this oven.
6. Use this appliance only for its intended use as described in the manual. Do not use corrosive chemicals or vapors in this appliance. This type of oven is specifically designed to heat, cook, dry, or defrost food. It is not designed for industrial, laboratory, or commercial use. It is intended for home use only. Do not use for drying clothes, linens, newspaper, or similar non-food type items.
7. Make sure that all persons using this appliance, especially children, are closely supervised and properly instructed on how to use this appliance.
8. Do not operate this appliance if it has a damaged cord or plug, if it is not working properly, or if it has been damaged or dropped.
9. This appliance should be serviced only by qualified service personnel. Contact the nearest authorized service facility for examination, repair or replacement. Do not attempt to service or repair this appliance.
10. Do not cover or block any openings on the appliance. Do not store items on top of microwave oven if there are louvers on top of oven.
11. Do not store this appliance outdoors. Do not use this product near water—for example, near a kitchen sink, in a wet basement, or near a swimming pool, and the like.
12. Do not immerse cord or plug in water.
13. Keep cord away from heated surfaces.
14. Do not let cord hang over edge of table or counter.
15. When cleaning surfaces of door and oven that come together on closing the door, use only mild, nonabrasive soaps or detergents applied with a sponge or soft cloth.
16. To reduce the risk of fire in the oven cavity:
 - a. Do not overcook food, especially starchy items such as potatoes and fatty items such as bacon. Carefully attend appliance if paper, plastic, or other combustible materials are placed inside the oven to facilitate cooking.
 - b. Remove wire twist-ties from paper or plastic bag before placing bag in oven.
 - c. If materials inside the oven should ignite, keep oven door closed, turn oven off, and disconnect the power cord, or shut off power at the fuse or circuit breaker panel.
 - d. Do not use the cavity for storage purposes. Do not leave paper products, cooking utensils, or food in the cavity when not in use.
 - e. Do not put metal inside the oven, except as specifically described in the manual or cookbook if supplied with this oven.

TABLE OF CONTENTS

clause	contents	page
00	Introduction and Safety precautions	
1	Introduction	1
2	Safety Precautions	2
3	Exploded Views	3
4	Schematic Diagrams	4
5	Parts List	5
	Heating Principle of Microwave	6
	Troubleshooting Procedures	7
	Common breakdown and means of repairing	12
	Critical Parts Servicing	13
	important things to do prior to critical parts servicing	13
2	interlock assembly replacement and adjustment	13
3	door and hinge replacement and adjustment	13
4	magnetron replacement	13
	Safety checks and tests after servicing	14
1	constructional checks	14
2	insulation resistance test	14
3	microwave leakage test	15

INTRODUCTION

This Microwave Oven Service Manual is printed in a loose leaf format. Each part is divided into sections relating to a general group of components and each section is subdivided into various parts describing a particular component or service procedure.

The subdividing of the subject matter plus the loose leaf form will facilitate the updating of the manual as new or revised components and service procedures are introduced.

Each page of this service manual will be identified in the lower right hand corner and as new or revised pages are published it will be easy to keep the manual up to date by following the filing instructions on the cover letter.

This Service Manual is a valuable service tool and care should be taken to keep it up to date by prompt and proper filing of subsequent pages as they are issued.

SAFETY PRECAUTIONS

PRECAUTIONS TO BE OBSERVED BEFORE AND DURING SERVICING TO AVOID POSSIBLE EXPOSURE TO EXCESSIVE MICROWAVE ENERGY:

- A. Do not operate or allow the oven to be operated with the door open.
- B. Make the following safety checks on all ovens to be serviced before activating the magnetron or other microwave source, and make repairs as necessary.
 - (1) Interlock operation
 - (2) Proper door closing
 - (3) Seal and sealing surfaces (arcing, wear, and other damage).
 - (4) Damage to or loosening of hinges and latches.
 - (5) Evidence of dropping or abuse.
- C. Before turning on microwave power for any service test or inspection within the microwave generating compartments, check the magnetron, wave guide or transmission line, and cavity for proper alignment, integrity, and connections.
- D. Any defective or misadjusted components in the interlock, monitor, door seal and microwave generation and transmission systems shall be repaired, replaced, or adjusted by procedures described in this manual before the oven is released to the owner.
- E. A microwave leakage check to verify compliance with the Federal performance standard should be performed on each oven prior to release to the owner.
- F. Operate the oven from a properly grounded AC outlet capable of supplying 120 volts at 15 amperes.

THIS MANUAL, AS WELL AS THE INFORMATION CONTAINED IN IT, IS TO BE USED ONLY BY AN AUTHORIZED SERVICE TECHNICIAN FAMILIAR WITH AND KNOWLEDGEABLE OF PROPER SAFETY AND SERVICING PROCEDURES AND POSSESSING HIGH QUALITY TEST EQUIPMENT ASSOCIATED WITH MICROWAVE AND ELECTRICAL APPLIANCE REPAIR.

ALL INDIVIDUALS WHO ATTEMPT REPAIRS BY IMPROPER MEANS OR ADJUSTMENT, SUBJECT THEMSELVES AND OTHERS TO THE RISK OF SERIOUS OR FATAL INJURY.

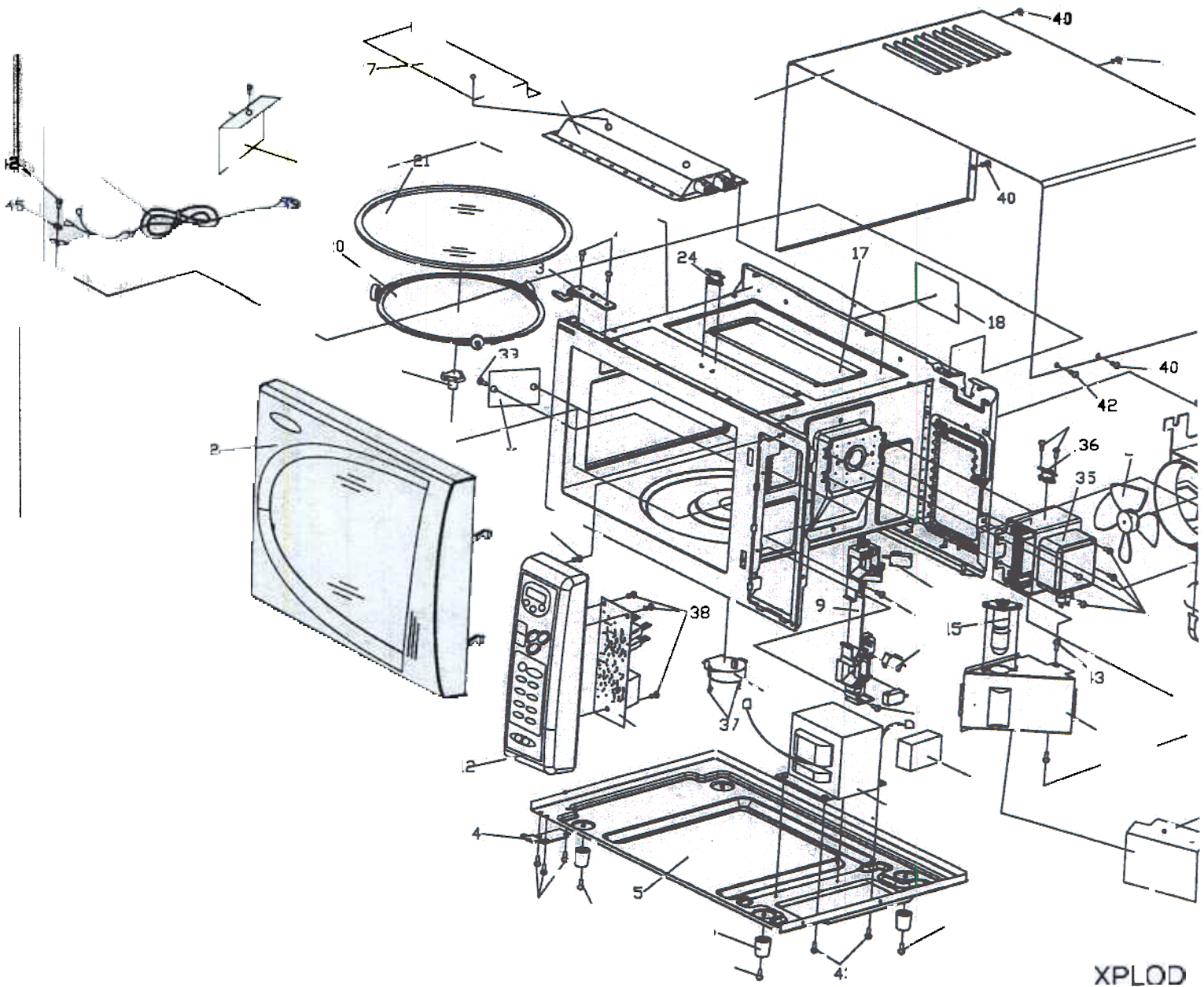

XPLOD
MOD L.

THE HEATING PRINCIPLE OF MICROWAVE

Microwave is one kind of radio wave whose wavelength is very short, frequency is very high. Therefore, it is called ultrahigh frequency electromagnetic wave. Microwave can heat food mainly result in the mutual affect of the food in the microwave field and the microwave field itself.

Under the affect of microwave field, the thermal effect mechanism produced from the mutual affect of the microwave and the food includes two aspects: One is Dielectric loss of polar molecule, the other is conductive loss of ion.

Usually, food is constitute of organism(plant and animal). The organism is formed by all kinds of polar water molecule, polar protein molecule, and all sorts of salt ion. The center of gravity of the positive and negative charge in the molecule is not coincide. In normal condition, the molecule is in irregular order due to its thermal action, thus the food do not appear polarity. (FIG.1 - 1a). Under the action of outer electric field, the positive end of the polar molecule trend to the negative electric field, the negative end of polar molecule trend to the positive electric field, and somewhat arrange in order through the direction of the electric field(FIG.1 - 1c). This phenomenon usually be called "TORQUE POLARITY". When the outer electric field apply for the opposite polarity, the polar molecule then arrange an opposite direction order accordingly(FIG.1 - 1b). If the direction of the outer electric field changed repeatedly, the polar molecule would repeatedly sway accordingly. During the swaying, it is understanding that the polar molecule would produce heat due to somewhat similar friction among them. When

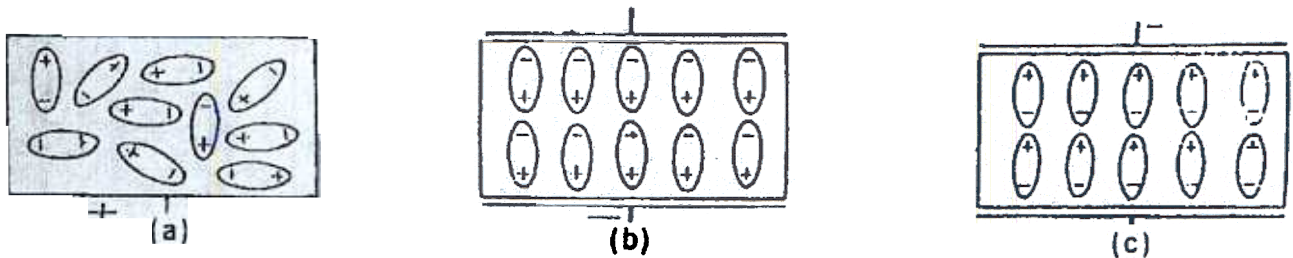

Fig1 -

the electric field is applied for ultrahigh frequent microwave field from the outside, its direction would change tens billion times per second, so do the molecule. This kind of molecule swaying producing similar frictional heat from the interference and block of the action strength among the molecule, and changed to microscopic microwave heating. Microwave heating not only concerned the nature of the matter itself, but also closely connected with the electric field strength and frequency. When the frequency is low, the molecule swaying rate and the acute degree of the mutual friction among the molecule is low, and would produce much heat. When the frequency is too high, as the swing of the polar molecule is with rotating inertia, it made the swing do not in line with the changing rhythm of the electric field because of the friction drag, thus, actually lowed the polar molecule swaying speed. The friction dragging degree is concerning about the magnelectric wave frequency, polar molecule shape, and the matter's sticky degree. To different matter's molecule, there are different special frequency zone. Those who absorb microwave energy from these zone are most capable to turn microwave energy to heat energy.

Apart from the above said action, there is another action which is electric ion under the action of microwave field, act fiercely accompanied with the acceleration of electric field. The positive ion transfer to the negative polarity of the field while the negative ion do opposite. Accompanying with the changing electric field, the electric ion changing accordingly. During the transferring, heat produced with the crash among the ion. This kind of action take the main effect to those microwave heating of high salt molecule.

No matter it is the polar molecule swaying or the ion transferring, they both are turning the microwave energy which the heating matter got from the microwave field to heat energy. From the analysis of theory, we can draw such a conclusion that the power which a unit of volume matter absorbed from the microwave field as the following formula:

$$P_a = KE f \epsilon r \tan \delta$$

P_a Stands for the power the heated matter absorbed from the microwave field.

K Stands for a constant

E Stand for microwave field strength

f Stands for the microwave frequency.

$\epsilon r \tan \delta$ Stands for loss angle tangent of the heated matter

TROUBLESHOOTING PROCEDURES

Before overhauling a microwave oven, you should judge the breakdown and the cause correctly, then you can repair it with corresponding ways. The overhauling must be proceed in order, any hasty conclusion is not recommendable, otherwise overworking would be done when repair. The microwave oven may occur compound breakdown due to all kinds of different reasons, thus, when overhaul, they all should be take into consideration. Special attention must be given to the microwave leakage and the electric insulation when examine because they may do harmful to the repairing staff.

I. MEANS OF THE BREAKDOWN EXAMINING.

How to examine a microwave oven with breakdown? A better means which demonstrated in practical operating are through inspecting and listening. On the basis of large amounts of perceptual knowledge, you can judge and analysis the breakdown quickly and correctl.

1. Inspection.

Inspect whether the oven shape is disordered and where is the disordered position, if any. It is normal if the cabinet disordered a little, but abnormal if the oven, the door disordered, the door hook broken, the door crooked, or there are too much looseness between the door and the oven after the door is closed.

2. Listening.

Listening to the voice of the oven operating and the noise of the fan after it conducted. Minor "wen wen" noise, cycling "kala" noise and "shishi" noise should be consider as normal. But it is abnormal if the following noise occurred:

- (1) Sound "wen wen" noise.
- (2) Long time "shishi" noise.
- (3) Strike voice like "pipa pipa".

II. SPOT EXAMINING STEPS OF THE MICROWAVE OVEN.

1. Examine the microwave insulating resistance.

Measure the insulating resistance with a avometer or a megaohmmeter the value should not less than 2 megaohm. Otherwise, part examination should be taken at once. Such as checking whether the motor, the thermal cutout, the transformer or the capacitor are electricity leaking.

2. Examination of the resistance value of the microwave oven.

Close the door, set the time (the oven is at operating condition but the power plug havn't been plugged in). measure the two feet (L-N) of the power plug with R × 1 grade of a avometer, the resistance value should be about 2.5 ohm. If open circuit occurred, then you must check whether the 8A fuse is broken, the primary winding of the transformer is open circuit, the thermal cutout is open circuit or not, you must check whether the interlock device is put through or all the plugs are connected well. If short circuit occurred or the resistance less than 1.5 ohm, you should check whether the primary winding of the power transformer is short-circuited or part short-circuited.

3. Examination of microwave leakage.

Measure the microwave leakage with a microwave leakage measure. Place a graduate of 275ml water at the middle of the glass tray of the oven (FIG. 5-1). Close the door, power set high, time set to 3 minutes, press the starting button to operate the oven. After recitified the microwave leakage measure, measure around the door crack, those hole position of the window and the air vent at four sides of the oven with the probe of the measure. When measure, the moving speed of the probe should not exceed 25mm per second, and the mersuring direction should be the same with the outing direction of the microwave leakage (FIG. 5-2).

When measuring, the ultimate value of microwave leakage of all the measured position should not exceed 1 milliwatt/cm², or should be considered as abnormal.

4. Examine when the oven at operating, but the food can't be heated.

- (1) Examine when the lamp is on, the glass tray is cycling, the fan operating in normal:

Take off the cabinet, starting the oven, measure the plug of the transformer with a avometer to see whether it is enough to 120v. If it is enough to 120v, then the secondary high voltage of the transformer should be examined as FIG. 5-3.

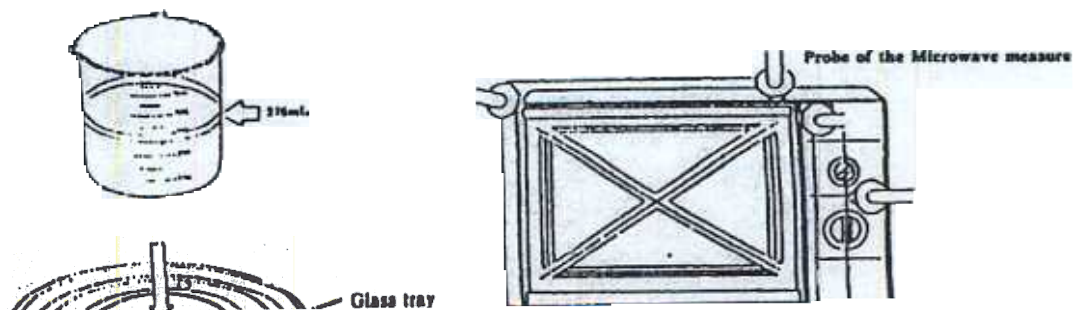

Measure it with the 2500V alternating grade of model 500 avometer. One rod of the avometer connect the iron core of the transformer, the other rod connect the secondary high voltage plug (FIG. 5 - 4). The avometer reading should be about 2100V (when measure, be careful with the high voltage). If no voltage at all, it indicates that the transformer has broken, and should be replaced by a new one. If it is enough to 2100V, then check the filament voltage of the transformer with alternating 10V grade of a avometer, the value should be about 3.4V (FIG. 5 - 5).

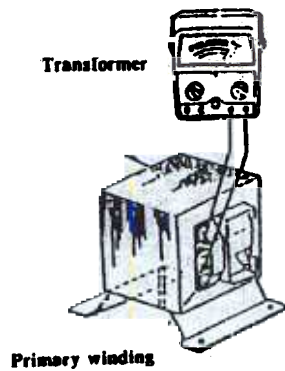

Fig. 5 - 3

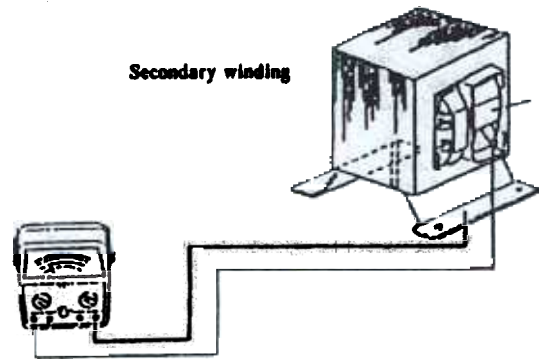

Fig. 5 - 4

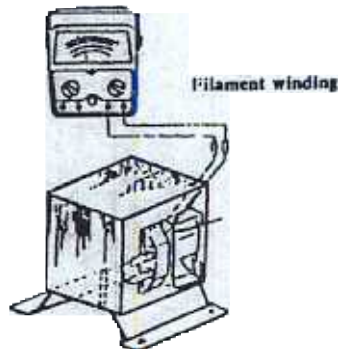

Fig. 5 - 5

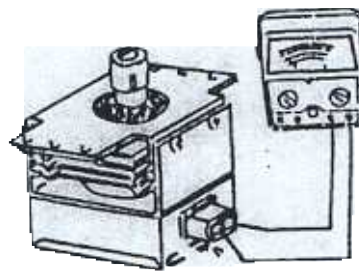

Fig. 5 - 6

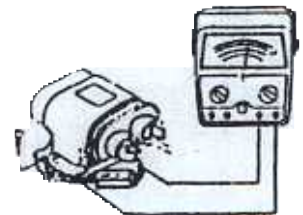

Fig. 5 - 7

If there is no voltage at all, it indicates the transformer has broken, and should be replaced by a new one. If it is enough to 3.4V, check the filament resistance of the magnetron, measure the filament plug with the $R \times 1$ grade of a avometer (FIG. 5 - 6). If it is open - circuited, it indicates the magnetron has broken, and should be replaced by a new one. It is normal if the resistance value is very small. Then check whether the magnetron steel has broken, if broken, replace with a new magnetron.

If there is no problem with the magnetron, check the high voltage diode then. Measure the diode with $R \times 10K$ grade of a avometer, the "+" rod end of the avometer connect the cathode of the diode, the "-" rod end of the avometer connect the anode of the diode (FIG. 5 - 7). The avometer reading should be about 150 thousand ohm. Then change the rod to different electrode, the reading should be " ∞ ". If the reading is very small, and near to short circuit, it indicates the high voltage diode has been punctured, and should be replaced by a new one.

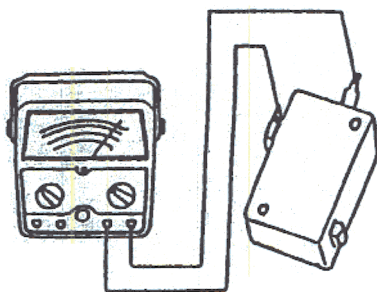

Fig. 5 - 8

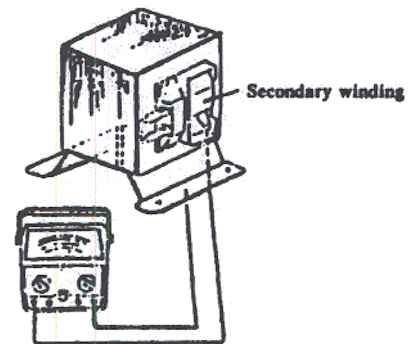

Fig. 5 - 9

If the high voltage diode is OK, then check the forwarding plug of the transformer to see whether it is enough to 120v. If it is not enough, check the micro-switch of the time and power distributor. Connect the two rod of the avometer to the 1, 2 place of the timer with R × 1K grade. It is normal if the reading is "0" when at cut off condition. If the reading is "∞", it indicates the micro switch has broken, and the timer should be replaced by a new one. If all the above examination shows normal, then check whether the terminal plug of the magnetron and the capacitor have loused, if it is loused, pinch it tightly with a pliers.

5. Examine the starting and the

Pull out the power plug, take off the cabinet, discharge the capacitor, measure the resistance value of the primary winding and the secondary winding of the transformer with a avometer (FIG. 5 - 10 and FIG. 5 - 9). The resistance value of the primary winding should be about 2.2 ohm, the secondary winding should be about 130 ohm. otherwise, it indicates the transformer has broken, and should be replaced by a new one.

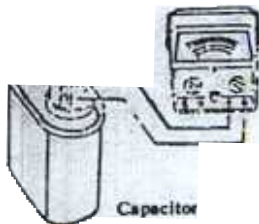

Fig. 5 - 1

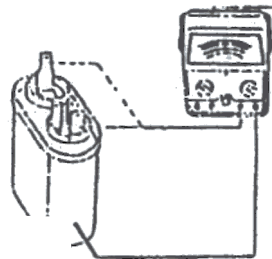

Fig. 5 - 12



Fig. 5 - 10

If the transformer is normal, then the high voltage capacitor should be checked. Pull out the connecting plug of the capacitor, and measure it with R × 1 grade of a avometer, the two rod of the avometer connect the two polarity of the capacitor. When they just connected, the reading of the avometer should be zero, then enlarge to nine megaohm slowly. Change the rod to different polarity, the reading repeat from zero to nine megaohm (FIG. 5 - 11), it means the capacitor is normal. If the indicator of the avometer can't point out from zero to nine megaohm, it indicates the high voltage capacitor has broken, and should be replaced by a new one.

If it is normal between the two pole of the capacitor, then the insulation between the capacitor pole and the cabinet should be measured with R × 10K grade of a avometer. The resistance value should be "∞" (FIG. 5 - 12). If it is short circuited or have a number reading, it indicates that the capacitor has been punctured or electricity leaked, and should be replaced by a same model, same capacity one.

If the resistance value of the capacitor's two pole are "∞", the capacitor is normal. Then check the earth of the magnetron's two filament to see whether they are short-circuited (FIG. 5 - 13). If they are short-circuited and the filament strikes the shell of the magnetron, it indicates the magnetron has broken, and should be replaced by a new, same model one.

If the magnetron is also normal, then test the pilot switch. Pull out the two plugs of the switch. Measure it with the R × 1 grade of a avometer, the two rod connect the plug of the switch, the resistance value should be "∞" (FIG. 5 - 8). Then press down the pilot switch with a screwdriver, if the reading of the avometer pointed to zero, it indicates the pilot switch has broken, and should replace it with a new, same model one.

II. REPAIRING METHOD OF SEVERAL BREAKDOWN

1. Repair when there occurred large amounts microwave leakage. There are many factors which may cause microwave leaking. Following mentioned may be the main cause of microwave leakage:

- (1) The door deformed, the hinge loused or damaged that caused the door can not close tightly.
- (2) The door pressing cover or the embed piece damaged or come off.
- (3) Obvious damage or uneven of the oven.
- (4) There are filth between the door and the oven.
- (5) The door and the oven are serious loused after the door closed.

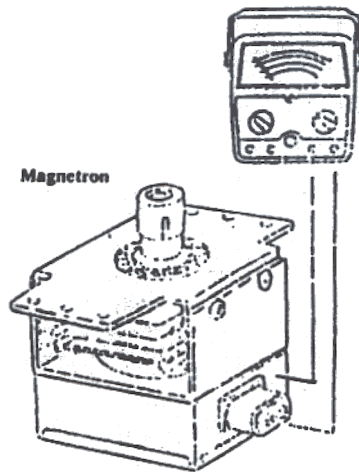

Fig. 5 - 13

(6) The crack of the door shielding net cover.

Before repairing, check whether the above listed point are existed. if not, can you start the microwave oven. Place a graduate of about 275ml water at the middle of the glass tray, close the door, time set at 3 minutes, power at high, make the oven operating in normal. Rectify the microwave leakage measure, measure the amount of the microwave leakage around the oven with its probe. If there are places which the leakage exceed the standard requirement, then repair them accordingly. If the leakage amount exceed 1 milliwatt/cm² at the left door crack, then pull out the power plug, take down the cabinet, adjust the screws of the hinge (up and low) as figure 5 - 14 to less the gap between the door and the oven. Then measure again, the leakage amount should less than 1 milliwatt/cm². Generally, it should be controled below 0.75 milliwatt/cm² with some allowance.

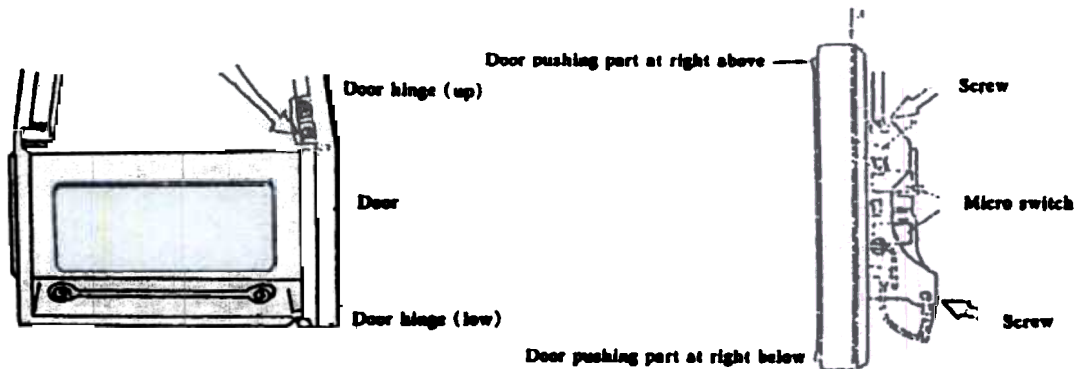

Fig. 5 - 14

Fig. 5 - 15

If the leakage occurred at the right door crack, adjust the screws which fix the interlock holder and the hook. If the leakage is on the larger side at the right - above of the oven, then adjust the upper screw as FIG. 5 - 15. Loosen out the screw, push the door close to the oven to hook the door hook with the plastic parts, then tighten the Screw again. If the leakage is larger at the right - below, then adjust the lower screw as FIG. 5 - 15. Loosen the screw, push the door close to the oven to hook the door hook with the switch holder tightly, then tighten the screw again, and open and close the door repeatedly to check whether the door can operate flexibly, whether the hook and the switch are in their normal position. If it is not in position, then adjust the door hook and the switch holder repeatedly to make them to the normal position, to put through the interlocks, to cut off the pilot switch, to less the loose between the door and the oven, then measure the leakage with microwave leakage measure again. If the leakage still exceed standard requirement, then inspect whether the right oven is even or not, if not, smooth it. Then adjust the door and the oven to eliminate their loose to the ultimate.

If there still exist microwave leakage, measure near the magnetron with the probe of the microwave leakage measure. If the leakage is larger, the oven should be turned off and check whether the four screws which fix the magnetron have been loosed. If loosed, twist them tightly with socket wrench. If the four screws are fixedly, then the magnetron should be take down to check the copper filament weaved washer of the magnetron has been placed well or whether the wave guide housing coupling has been oxidized or have lacquer on it. If do have, scrape the oxidized layer or the lacquer off. when fix the magnetron, the copper filament weaved washer must be placed well, the screws must be twist tightly. Then turn on the oven and measure again until it comply with the requirement. If the microwave leakage is larger at those hole position of the window board, the oven should be turned off to inspect whether there are crack among them (fig.5 - 17). If several holes formed a crack, it would enlarge the microwave leakage. If that is the case, it indicates the door has broken, and should be replaced with a new door.

2. Means of repair when the oven can heat, but the turntable glass can't move

Firstly, check whether the turntable holder is placed correctly. If it is correct, then pull out the power plug and take down the turntable combination, measure the resistance value of the turntable motor with R X 1K grade of a avometer. If it is open - circuited, it indicates the turntable motor has broken, and should be replaced by a new, same model one. If the resistance value is between 15 - 22K, it indicates the turntable motor is normal. then check the connecting shaft weave. If the plastics which the shaft insert in has broken, a new shaft weave should replace it.

3. Repair when the oven can heat, but the lamp is not on.

Pull out the power plug, take down the cabinet and discharge the capacitor.

Pull out the two terminal plugs of the lamp. measure the two plugs of the lamp with the R X 100 grade of a avometer. If it is open - circuited, it indicates the lamp has broken, and should be replaced by a same model one.

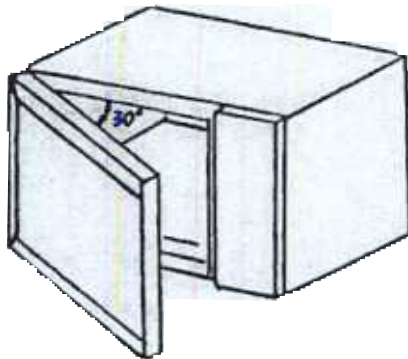

Fig.5 - 16

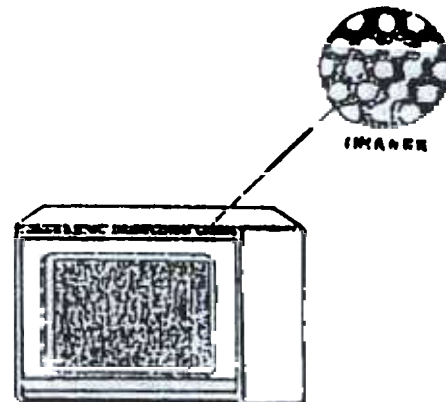

Fig.5 - 17

4. Means of repair when the oven stop working aftrer several minutes operating

The phenomenon indicates the thermal cutout is playing its protective role, and you should check whether the fan is working in normal. Turn off the oven, pull out the power plug, take down the cabinet, discharge the capacitor, then turn the fan with hand to see whether it is moving flexibly. If not, it indicates that the oil bearing of the fan motor has run off the oil, and should take down the fan combination to repair the motor. Loosen the two screws which fix the bearing out the shaft and the bearing, and rinse them with kerosene (ATTENTION: The bearing can only be wiped with a silk which moistened with kerosene rather than be washed in the kerosene because there are felt on it. If the felt are soaked with kerosene, then the engine oil can not be sucked up.). After the bearing being cleaned, the felt should be refuled fully with engine oil (for when the oven is operating, the engine oil empty into the oil bearing slowly). Fix the bearing cover with two screws, turn the fan around till it can move flexibly. Then install them to the oven, and plug in the two terminal plugs.

If the fan can move flexibly, then the winding of the fan motor should be examined. Measure the winding with R X 100 grade of a avometer, if it is open - circuited, it indicates the winding of the fan motor has broken, and should be replaced by a new, same model one.

COMMON BREAKDOWN AND MEANS OF REPAIRING

PHENOMENON	CAUSE	REPAIRING MEANS
1. When starting the oven, the lamp is not on, the turntable tray can't rotate and the food can't be heated	<ol style="list-style-type: none"> 1. fuse broken. 2. The primary and secondary winding of the transformer are short - circuited. 3. The earthing or the polarity of the capacitor is punctured. 4. The pilot switch can't cut off. 5. The interlock switch haven't closed. 6. The power plug and the socket are not in good connection. 7. The door hook broken. 	<ol style="list-style-type: none"> 1. Change a new fuse. 2. Change a new transformer 3. Change a new capacitor. 4. Change a new pilot switch 5. Change a new interlock switch. 6. Adjust the connection or replace it by a new one. 7. Change a new hook.
2. When starting the oven, the lamp is on, the turntable rotating, the fan cycling but the food can't be heated.	<ol style="list-style-type: none"> 1. The primary and secondary winding, the filament of the transformer are open - circuited. 2. The magnetron filament is open - circuited, the magnetic steel of the magnetron broken or the magnetron is air leaking. 3. Time and power distributor broken. 4. The plugs of the magnetron or the capacitor loosed. 	<ol style="list-style-type: none"> 1. Change a new transformer. 2. Change the magnetron. 3. Change the time power distributor or the micro - switch. 4. Fix them.
3. The food can be heated, but the lamp is not on	<ol style="list-style-type: none"> 1. The lamp broken 2. The plug fall off. 	<ol style="list-style-type: none"> 1. Change a new lamp 2. Insert the plug again
4. The food can be heated but the turntable tray is not rotating.	<ol style="list-style-type: none"> 1. The turntable motor broken 2. The plug fall off 3. Connecting shaft weave broken 	<ol style="list-style-type: none"> 1. Change the turntable motor 2. Insert the plug securely 3. Change the weave
5. The oven can heat within 2 - 3 minutes, but can not heat from the fourth minutes	<ol style="list-style-type: none"> 1. The winding of the fan motor in open - circuited. 2. The fan falls off 3. The plug of the fan motor falls off 4. The turntable shaft is griped with the motor bearin 5. The cooling vent blocked 	<ol style="list-style-type: none"> 1. Change the fan motor 2. Change the fan 3. Insert the plug 4. Overhauling them 5. Repairing it
6. When starting the oven, it can't heat, and with "wenwen" noise.	The high voltage diode was punctured	Change a new diode
7. The oven can heat, but with sound "shishi" noise	The iron core of the transformer loosed	Change a new transformer
8. Large amount of microwave leakage	<ol style="list-style-type: none"> 1. The door deformed 2. The door metal net cracked 3. The gap of the door crack is too large 4. The welding point of the oven fall off 5. The screws which fix the magnetron loosed 6. The wave guide connection oxidized. 7. The magnetron copper filament washer is too thin cause the wave guide opening not in good earth. 	<ol style="list-style-type: none"> 1. Mend the door 2. Change the door 3. Adjust the gap 4. Change the oven 5. Tighten the screws 6. Scrape the oxidized and tighten the screws 7. Thick the copper filament washer
9. The door can't open	<ol style="list-style-type: none"> 1. After long time using, the wear and the rust - eaten enlarged the gap of the door shaft and the shaft hole, thus cause the door crooked. 2. The door hook broken. 	<ol style="list-style-type: none"> 1. Adjust the hinge to rectify the position of the door. 2. Change the hook.
10. The door release button fall off	Wearred and aged after long time operating	Overhaul it or renew It
11. Electricity leaking	The earthing insulation resistance of all the motors or the trasformer are less than 2	Test where is the leaking place, then repair it or change those damaged components

CRITICAL PARTS SERVICING

IMPORTANT THINGS TO DO PRIOR TO CRITICAL PARTS SERVICING

The following instructions are **CRITICAL** to the owner's safety. Be sure to follow all the instructions. Contact the manufacturer or distributor if you have any question.

If the oven is operative prior to servicing, a Microwave Leakage Test (a.k.a. Microwave Emission Check) should be performed prior to servicing the oven. Refer to Section 7.3, Microwave Leakage Test, for the detailed check procedures.

- 1.2 In the event that any microwave oven found to have microwave emission level in excess of 4 mW/cm². The following procedures should be followed:
 - a. Inform the distributor, importer, or manufacturer the finding. Record it in the logbook as well.
 - b. Repair the unit at no cost to the owner.
 - c. Investigate the oven and ascertain the cause of the excessive leakage.
 - d. Hold the oven in your facility and instruct the owner not to use the unit until the oven has been brought into compliance.
- 1.3 In the event that the oven operates with the door open. The following procedures should be followed:
 - a. Tell the user not to operate the oven.
 - b. Hold the oven in your facility until it is investigated and repaired.
 - c. Contact the manufacturer and CDRH (FDA) immediately!

2 Interlock Assembly Replacement and Adjustment

- 2.1 If you suspect defective primary, secondary or monitor interlock switches, use your ohmmeter (digital or analog type) to check the electrical continuity.
- 2.2 Make sure the power cord is pulled out and the high-voltage capacitor is discharged before the electrical continuity check.
- 2.3 Set the ohmmeter to "Low Resistance" range and connect both leads (alligator clips) to the switch terminals.
- 2.4 Open the door and notice the meter reading. The primary or secondary interlock switch should show an "infinite" resistance when the door is open. Replace it when it is defective. The monitor interlock should show a "zero or near zero" resistance when the door is open. When the door is closed, the readings will be opposite.
- 2.5 If the oven has been rendered inoperative due to the failure of the monitored safety (primary and/or secondary) interlock(s), you should replace all of the monitored safety interlock switches and the monitor switch.
- 2.6 Refer to Chapter 4, Sections I and X for how to remove and assemble the interlock and monitor switches.
- 2.7 Always refer to Section 0.4 for adequate wiring diagram. Monitor interlock must always be installed. Repeat Step 2.4 to check electrical continuity.
- 2.8 Perform required checks and tests as described in Chapter 7 before releasing the oven to the owner.

3 Door and Hinge Replacement and Adjustment

- 3.1 Pull the power cord from the outlet. Check the door for warped or damaged areas. Check the hinges for broken or worn areas. Check other areas such as cracked front glass, broken door latches, worn/ cracked viewing screen and etc.
- 3.2 After determining the door assembly should be replaced, check the parts list for the correct part number. All oven door components must be ordered directly from the manufacturer or its authorized distributor.
- 3.3 Refer to Chapter 4, Sections I, II, and III for how to disassemble, assemble and adjust the door and/or hinge.
- 3.4 Perform required checks and tests as described in Chapter 7 before releasing the oven to the owner.

4 Magnetron Replacement

- 4.1 Refer to Chapter 4, Section IV for removing and replacing the magnetron. Check for the presence of the wire mesh gasket before installation.
- 4.2 Perform required checks and tests as described in Chapter 7 before releasing the oven to the owner. Conduct a Microwave Leakage Test (Refer to Section 7.3) at the magnetron area prior to installing the top cover.

SAFETY CHECKS AND TESTS AFTER SERVICING

Constructional Checks

If mechanical or electrical (electronic) parts have been replaced, be sure to follow the following steps:

1. Check for correct wiring, adequate mechanical securements of parts, and firm connectors.
2. Check for adequate grounding.
- 1.3 Check the following items before turning the oven ON.
 - 1) Proper door closing, seal/ choke surfaces, and hinges.
 - 2) No cabinet damage.
 - 3) Proper interlock and monitor operations. (Refer to Steps 6.2.2 to 6.2.4.)

Insulation Resistance Test

If the low voltage power supply has been repaired, use a 500 V Megohmmeter to measure the resistance between the primary (Line and Neutral) of the power plug and operator accessible metal parts. The resistance should be no less than 2 Mega Ohms. Repair the oven again when necessary.

Microwave Leakage Test

In the event that magnetron, door, or hinge has been replaced or readjusted, a microwave test as follows must be preferred:

3.1 Test instruments required:

Microwave Survey Meter, Holaday Model EI-1710 or equivalent
600 ml glass beaker

3.2 Precautions:

Turn the power off (or unplug the oven) immediately if the oven fails this test.

3.3 Plug the oven power cord into the power receptacle.

3.4 Turn on the Microwave Leakage Meter and warm up for at least 10 minutes. Set the meter response (filter selection) at "FAST".

3.5 Fill the glass beaker with 275 (+/- 15) ml of cold tap water and place the beaker in the center of the turntable glass plate.

3.6 Close the oven door. Set the timer at "5 minutes". Set the Power Level at "HIGH" or "100 %" and start the operation.

3.7 Hold (by the handle portion) the probe (cone spacer) perpendicular to the areas under test for RF emissions. Move the probe at a speed of no faster than 1 inch per second. The areas under test are:

- 1) The circumference of the door/cavity seal.
- 2) The area of the door screen.
- 3) The area of control panel.
- 4) The area near line cord.
- 5) All vent openings.
- 6) All cabinet seams.
- 7) Other suspect areas.

3.8 At several locations in the vicinity of each high leakage point, hold the probe stationary until a steady state value is reached on the Survey Meter. Observe the maximum leakage at each location.

3.9 Set the Meter Response to "SLOW": remeasure the leakage at the point of maximum leakage located in Step 3.8 above, record the value and location of the maximum leakage measurement with the meter response on "SLOW".

3.10 The maximum RF emission (leakage) should be 4.0 mW/cm² or less. If not, investigate and repair the oven again until it passes the test.