

OEM Serial Port Adapter™

cB-0901

Electrical & Mechanical Datasheet

connectBlue

OEM Serial Port Adapter™
cB-0901

Electrical & Mechanical Datasheet

Copyright © 2005 connectBlue AB.

The contents of this document can be changed by connectBlue AB without prior notice and do not constitute any binding undertakings from connectBlue AB. connectBlue AB is not responsible under any circumstances for direct, indirect, unexpected damage or consequent damage that is caused by this document.

All rights reserved.

Release: 2005-11

Document version: 1.1

Document number: cBProduct-0410-04

Printed in Sweden.

Trademarks

Registered trademarks from other companies are: Bluetooth is a trademark owned by the Bluetooth SIG, Inc., Microsoft™, Windows™, Windows NT™, Windows 2000™, Windows CE™, Windows ME™, are registered trademarks from Microsoft Corporation.

Contents

1	Introduction	5
1.1	Related Documents.....	5
1.2	Product Variants.....	6
1.3	cB-0901	7
1.4	Block Diagram cB-0901.....	8
2	Electrical Interface and Connectors	9
2.1	Pin Numbering	10
2.2	Pin Description.....	11
2.3	Characteristics	19
2.4	Hardware Reset	23
2.5	Power Control	23
3	Operating Status	24
4	Antennas	25
4.1	Surface Mounted Antenna (Internal).....	25
4.2	External antennas	26
5	Mounting Information	29
5.1	Board Outlines	29
5.2	Using the J2/J3 Board-to-Board Connectors.....	31
5.3	Using Press-Fit Nuts for Mounting the Module.....	35
5.4	Using the J6 PCB solder pads on the edge.....	35
5.5	Antenna Issues	35
6	Bluetooth Information	36
6.1	General information.....	36
6.2	Bluetooth Qualification information	37
7	Regulatory Information	38
7.1	Declaration of Conformity	38
7.2	FCC, IC and Safety Compliance.....	39
7.3	UL listing information.....	43
7.4	Compliance with RoHS directive.....	43
Appendix A -	Application Notes	44
A.1	Step-by-Step Guide.....	44
A.2	Design Examples	45

1 Introduction

1.1 Related Documents

There are some documents related to the Serial Port Adapter:

- The **Serial Port Adapter AT Commands** document contains a description of the AT commands supported in the Serial Port Adapter. It also contains information on how to use the AT commands to create Bluetooth applications.
- The **OEM Serial Port Adapter Electrical & Mechanical Datasheet** (this document) contains important information about the OEM Serial Port Adapter. Read this document if you are using the OEM Serial Port Adapter.

1.2 Product Variants

This Electrical and Mechanical datasheet contains information about the 12 variants of OEM Serial Port Adapters based on the PCB cB-0901. This document makes references to the OEM Module ID, not the Product Name (see Table 1).

Table 1: Product variants

	Product Name	OEM Module ID / FCC Type No.	Bluetooth Type	Description
Class 1 +7dBm Internal antenna	CB-OEMSPA311i-04	cB-0052 cB-0901-0301	Class 1 / +7dBm 5mW	OEM Serial Port Adapter 311i with internal antenna, no connectors
	CB-OEMSPA311i-06	cB-0054 cB-0901-0301	Class 1 / +7dBm 5mW	OEM Serial Port Adapter 311i with internal antenna, JST 6-pol
	CB-OEMSPA311i-07	cB-0055 cB-0901-0301	Class 1 / +7dBm 5mW	OEM Serial Port Adapter 311i with internal antenna, Flexfilm
Class 1 +7dBm External antenna	CB-OEMSPA311x-04	cB-0056 cB-0901-0301	Class 1 / +7dBm 5mW	OEM Serial Port Adapter 311x with external antenna, no connectors
	CB-OEMSPA311x-06	cB-0058 cB-0901-0301	Class 1 / +7dBm 5mW	OEM Serial Port Adapter 311x with external antenna, JST 6-pol
	CB-OEMSPA311x-07	cB-0059 cB-0901-0301	Class 1 / +7dBm 5mW	OEM Serial Port Adapter 311x with external antenna, Flexfilm
Class 1 +17dBm Internal antenna	CB-OEMSPA331i-04	cB-0060 cB-0901-0302	Class 1 / +16.9dBm 49mW	OEM Serial Port Adapter 331i with internal antenna, no connectors
	CB-OEMSPA331i-06	cB-0062 cB-0901-0302	Class 1 / +16.9dBm 49mW	OEM Serial Port Adapter 331i with internal antenna, JST 6-pol
	CB-OEMSPA331i-07	cB-0063 cB-0901-0302	Class 1 / +16.9dBm 49mW	OEM Serial Port Adapter 331i with internal antenna, Flexfilm
Class 1 +17dBm External antenna	CB-OEMSPA331x-04	cB-0064 cB-0901-0302	Class 1 / +16.9dBm 49mW	OEM Serial Port Adapter 331x with external antenna, no connectors
	CB-OEMSPA331x-06	cB-0066 cB-0901-0302	Class 1 / +16.9dBm 49mW	OEM Serial Port Adapter 331x with external antenna, JST 6-pol
	CB-OEMSPA331x-07	cB-0067 cB-0901-0302	Class 1 / +16.9dBm 49mW	OEM Serial Port Adapter 331x with external antenna, Flexfilm

1.3 cB-0901

cB-0901 is a small size Bluetooth module based on the Phillips BGB203 system in package (SiP). The BGB203 has on chip SRAM and FLASH stacked in the same package. The modules are available in many variants with different antenna / connectors and output power combinations. See Picture 1 - Picture 3 for some of the available models. All models are described in Table 1.



**Picture 1: CB-OEMSPA331x-06
OEM Serial Port Adapter long
range with external antenna and a
JST 6-pol connector**



**Picture 2: CB-OEMSPA311i-07
OEM Serial Port Adapter short
range with internal antenna and a
flexfilm connector**



**Picture 3: CB-OEMSPA331i-06
OEM Serial Port Adapter long
range with internal antenna and a
JST 6-pol connector**

1.4 Block Diagram cB-0901

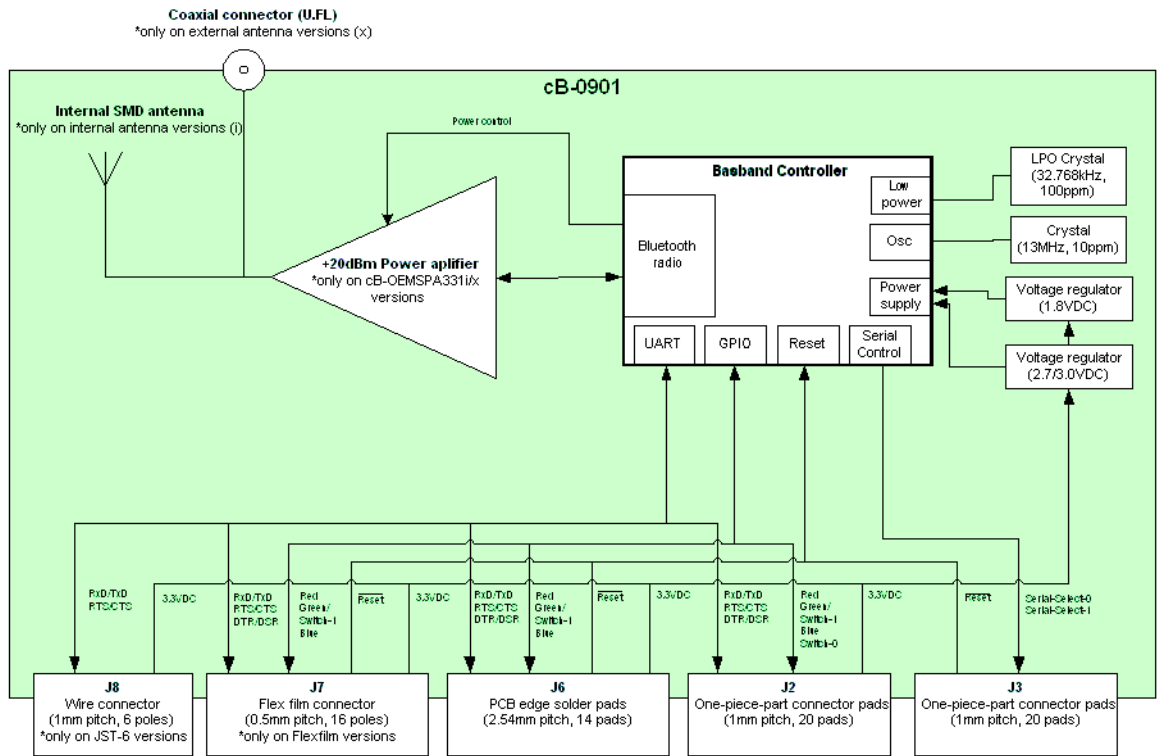

Figure 1: Block diagram of cB-0901

2 Electrical Interface and Connectors

This section describes the signals available on the module interface connectors.

There are four ways to connect to the OEM Serial Port Adapter:

- Via the PCB solder pads on the edge of the PCB, J6 (see Picture 4). See Section 5.4 for more information.
- Via the 2x20-pin 1mm pitch board-to-board (one piece part) connectors, J2 through J3. The J2 to J3 connectors on the OEM Serial Port Adapter exist on the module only as a mating PCB-layout pattern (see Picture 5). See Section 5.2 for more information.

Optional:

- Via the JST connector, J8 (see Picture 6). The connector is a 6 poles wire connector. The pitch is 1mm and the. The connector is from JST with part number SM06B-SRSS-TB.
- Via the flexfilm connector, J7 (see Picture 7). The connector is a 16 poles flexfilm connector. The pitch is 0.5mm and the flexfilm should be 0.3mm thick. The connector is from Hirose with part number FH19S-16S-0.5SH(05).

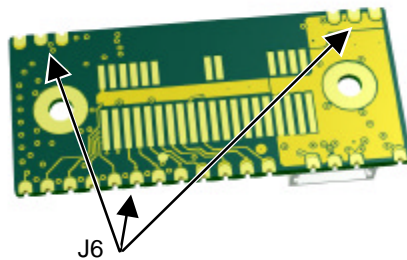

Picture 4: J6 are available on the edge of the cB-0901.

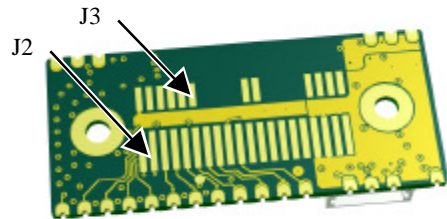

Picture 5: J2 to J3 are available on cB-0901. Some of the not used pads are not visible.

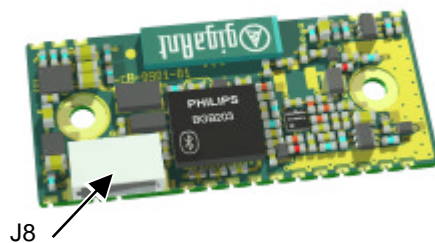

Picture 6: JST 6-pol connector, J8.

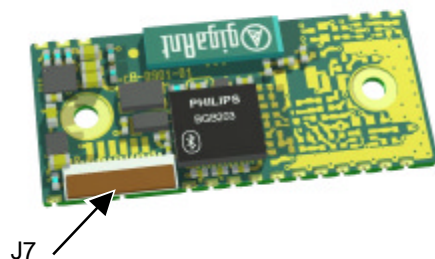

Picture 7: Flexfilm connector, J7.

2.1 Pin Numbering

2.1.1 J2, J3 and J6 Connectors

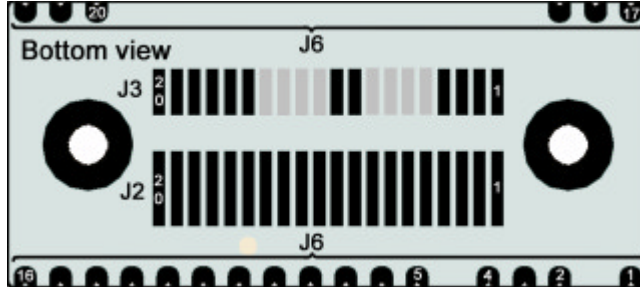

Figure 2: Bottom view of the PCB with the pinning of the J2, J3 and the J6 connector.

2.1.2 JST 6-pol, J8

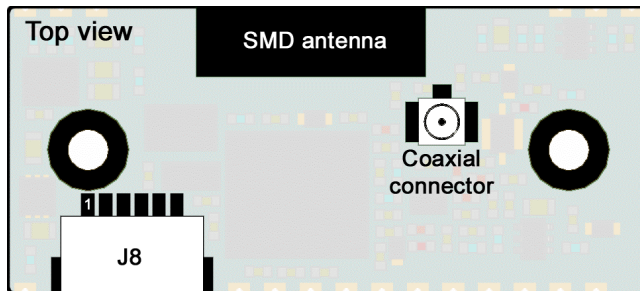

Figure 3: Top view of the PCB with the pinning of the J8 connector.

2.1.3 Flexfilm, J7

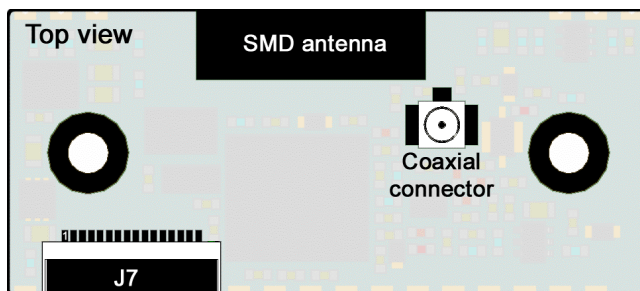

Figure 4: Top view of the PCB with the pinning of the J7 connector.

2.2 Pin Description

2.2.1 J2 Connector

Table 2: Signals on J2.

J2 Pin Nr	Pin Name	Signal Name	Signal Level	Type	Description
1-2	VSS	Ground	Ground		GND
3-4	VCC_3V3	Power	3.3V		3.0 – 6.0 VDC for CB-OEMSPA311 modules 3.3 – 6.0 VDC for CB-OEMSPA331 modules
5-10		Reserved			Reserved, do not connect.
11	RED/Mode	Red LED output	CMOS	In/Out	Logic Red LED Signal (see Chapter 3, Table 14). Pin is used as input for approximately 500ms at startup. Mode: Not used on cB-0901. This pin is also used to select Logic level mode (instead of RS232) for connectBlue product with internal RS232 driver. To be compatible with these products check the datasheet for these products about this signal. See section A.2.3.2 for design examples.
12	Switch-0	Function switch	CMOS	In	Used for the “Connect on external signal” function, see the Serial Port Adapter AT command Specification for more information on the Function switch. See section A.2.3.4 for design examples.

J2 Pin Nr	Pin Name	Signal Name	Signal Level	Type	Description
13	GREEN/ Switch-1	Green LED output and Restore switch	CMOS	In/Out	<p>This signal is multiplexed:</p> <p>GREEN: Logic Green LED Signal (see Chapter 3, Table 14). Not valid until 500ms after startup.</p> <p>Switch-1: If the level on this pin is set to Low the units goes back to default serial settings.</p> <p>The "Restore Default" input is only active during the first 500ms after startup.</p> <p>See the Serial Port Adapter AT command Specification for more information on the Restore switch.</p> <p>See section A.2.3.3 for design examples.</p>
14	BLUE	Blue LED output	CMOS	Out	<p>Logic Blue LED Signal (see Chapter 3, Table 14).</p> <p>Note: Signal will flicker at data transmission.</p> <p>See section A.2.3.1 for design examples.</p>
15	UART-CTS*	Clear To Send	CMOS	In	Hardware flow control.
16	UART-TxD*	Transmit Data	CMOS	Out	
17	UART-RTS*	Request To Send	CMOS	Out	Hardware flow control.
18	UART-RxD*	Receive Data	CMOS	In	
19	UART-DTR*	Data Terminal Ready	CMOS	Out	
20	UART-DSR*	Data Set Ready	CMOS	In	

* All signals are logic level UART signals (typically 0 - 3VDC)

2.2.2 J3 Connector

Table 3: Signals on J3

J3 Pin Nr	Pin Name	Signal Name	Signal Level	Type	Description
1-8					Reserved, do not connect.
9	SerialSelect-0	Serial Select 0	CMOS	Out	Reserved, do not connect.
10	SerialSelect-1	Serial Select 1	CMOS	Out	Reserved, do not connect.
11-18					Reserved, do not connect.
19	$\overline{\text{RESET}}$	Hardware reset	CMOS	In	Active low. Must be open drain collector. See section 2.4 for design examples.
20					Reserved, do not connect.

2.2.3 J6 Connector (Solder pads)

Table 4: Signals on J6

J6 Pin Nr	Pin Name	Signal Name	Signal Level	Type	Description
1	RESET	Hardware reset	CMOS	In	Active low. Must be open drain collector. See section 2.4 for design examples.
2	VSS	Ground	Ground		GND
3	VCC_3V3	Power	3.3V		3.0 – 6.0 VDC for CB-OEMSPA311 modules 3.3 – 6.0 VDC for CB-OEMSPA331 modules
4	UART-DTR*	Data Terminal Ready	CMOS	Out	
5	RED/Mode	Red LED output	CMOS	Out	Logic Red LED Signal (see Chapter 3, Table 14). Pin is used as input for approximately 500ms at startup. Mode: Not used on cB-0901. This pin is also used to select Logic Level mode (instead of RS232) for connectBlue product with internal RS232 driver. To be compatible with these products check the datasheet for these products about this signal. See section A.2.3.2 for design examples.

J6 Pin Nr	Pin Name	Signal Name	Signal Level	Type	Description
6	GREEN/ Switch-1	Green LED output and Restore switch	CMOS	In/Out	<p>This signal is multiplexed:</p> <p>GREEN: Logic Green LED Signal (see Chapter 3, Table 14). Not valid until 500ms after startup.</p> <p>Switch-1: If the level on this pin is set to Low the units goes back to default serial settings.</p> <p>The "Restore Default" input is only active during the first 500ms after startup.</p> <p>See the Serial Port Adapter AT command Specification for more information on the Restore switch.</p> <p>See section A.2.3.3 for design examples.</p>
7	BLUE	Blue LED output	CMOS	Out	<p>Logic Blue LED Signal (see Chapter 3, Table 14).</p> <p>Note: Signal will flicker at data transmission.</p> <p>See section A.2.3.1 for design examples.</p>
8	UART-CTS*	Clear To Send	CMOS	In	Hardware flow control.
9	UART-TxD*	Transmit Data	CMOS	Out	
10	UART-RTS*	Request To Send	CMOS	Out	Hardware flow control.
11	UART-RxD*	Receive Data	CMOS	In	
12-15					Reserved, do not connect.
16	UART-DSR*	Data Set Ready	CMOS	In	
17-22		Attachment pads			Not electrically connected

* All signals are logic level UART signals (typically 0 - 3VDC)

2.2.4 J7 Connector (Flexfilm)

Table 5: Signals on J7

J7 Pin Nr	Pin Name	Signal Name	Signal Level	Type	Description
1	RESET	Hardware reset	CMOS	In	Active low. Must be open drain collector. See section 2.4 for design examples.
2	DSR	Data Set Ready	CMOS	In	
3	VSS	Ground	Ground		GND
4	VCC_3V3	Power	3.3V		3.0 – 6.0 VDC for CB-OEMSPA311 modules 3.3 – 6.0 VDC for CB-OEMSPA331 modules
5	DTR	Data Terminal Ready	CMOS	Out	
6	RED/Mode	Red LED output	CMOS	Out	Logic Red LED Signal (see Chapter 3, Table 14). Pin is used as input for approximately 500ms at startup. Mode: Not used on cB-0901. This pin is also used to select Logic Level mode (instead of RS232) for connectBlue product with internal RS232 driver. To be compatible with these products check the datasheet for these products about this signal. See section A.2.3.2 for design examples.

J7 Pin Nr	Pin Name	Signal Name	Signal Level	Type	Description
7	GREEN/ Switch-1	Green LED output and Restore switch	CMOS	In/Out	<p>This signal is multiplexed:</p> <p>GREEN: Logic Green LED Signal (see Chapter 3, Table 14). Not valid until 500ms after startup.</p> <p>Switch-1: If the level on this pin is set to Low the units goes back to default serial settings.</p> <p>The "Restore Default" input is only active during the first 500ms after startup.</p> <p>See the Serial Port Adapter AT command Specification for more information on the Restore switch.</p> <p>See section A.2.3.3 for design examples.</p>
8	BLUE	Blue LED output	CMOS	Out	<p>Logic Blue LED Signal (see Chapter 3, Table 14).</p> <p>Note: Signal will flicker at data transmission.</p> <p>See section A.2.3.1 for design examples.</p>
9	UART-TxD*	Transmit Data	CMOS	Out	
10	UART-RxD*	Receive Data	CMOS	In	
11	UART-CTS*	Clear To Send	CMOS	In	Hardware flow control.
12	UART-RTS*	Request To Send	CMOS	Out	Hardware flow control.
13-16					Reserved, do not connect.

* All signals are logic level UART signals (typically 0 - 3VDC)

2.2.5 J8 Connector (JST 6-pol)

Table 6: Signals on J8

J8 Pin Nr	Pin Name	Signal Name	Signal Level	Type	Description
1	VSS	Ground	Ground		GND
2	VCC_3V3	Power	3.3V		3.0 – 6.0 VDC for CB-OEMSPA311 modules 3.3 – 6.0 VDC for CB-OEMSPA331 modules
3	UART-TxD*	Transmit Data	CMOS	Out	
4	UART-RxD*	Receive Data	CMOS	In	
5	UART-CTS*	Clear To Send	CMOS	In	Hardware flow control.
6	UART-RTS*	Request To Send	CMOS	Out	Hardware flow control.

* All signals are logic level UART signals (typically 0 - 3VDC)

2.3 Characteristics

The cB-0901 board is designed to be fully interchangeable. If the host product has space for the board it is possible to choose freely between a cB-OEMSPA311i/x or cB-OEMSPA331i/x device without any change of the host product. If you design your power supply for cB-OEMSPA331i/x the modules will be fully interchangeable.

The cB-0901 module has a linear power supply, which means that the current is constant if the voltage supply is changed. See Table 10.

For more information about low power modes see Serial Port Adapter AT commands Specification.

2.3.1 Power supply

2.3.1.1 cB-OEMSPA311i/x products

Table 7: Power supply

Symbol	Parameter	Value	Unit
VCC_3V3	Power supply (Un-regulated*)	Min	3.0 VDC
		Max	6.0 VDC

* The module is equipped with an internal linear voltage regulator.

Table 8: Current consumption

Symbol	Mode	Value	Unit	
I _{cc}	Not connected	Average	7.9 mA	
		Peak	48 mA	
@ VCC_3V3 = 3.3V	Not connected, stop mode enabled	Not connectable	Average	1.0 mA
			Peak	1.2 mA
		Connectable	Average	1.8 mA
			Peak	48 mA
	Connectable, discoverable	Average	1.8 mA	
		Peak	48 mA	
	Connected	Idle or Receiving	Average	17 mA
			Peak	55 mA
		Transmitting @115.2kbit/s	Average	22 mA
			Peak	58 mA
	Inquiry	Average	39 mA	
		Peak	70 mA	

2.3.1.2 cB-OEMSPA331i/x products

Table 9: Power supply

Symbol	Parameter	Value	Unit
VCC_3V3	Power supply (Un-regulated*)	Min	3.3 VDC
		Max	6.0 VDC

* The module is equipped with an internal linear voltage regulator.

Table 10: Current consumption

Symbol	Mode		Value	Unit	
I _{CC} @ VCC_3V3 = 3.3V	Not connected Stop mode not enabled.		Average	19 mA	
			Peak	63 mA	
	Not connected, stop mode enabled	Not connectable		Average	10 mA
				Peak	13 mA
		Connectable		Average	11 mA
				Peak	60 mA
		Connectable, discoverable		Average	11 mA
				Peak	60 mA
	Connected	Idle or Receiving		Average	22 mA
				Peak	170 mA
		Transmitting @ 115.2kbit/s		Average	53 mA
				Peak	170 mA
		Inquiry		Average	84 mA
				Peak	150 mA

2.3.2 Input/Output signals

2.3.2.1 cB-OEMSPA311i/x products

Table 11: Input/output signals

Symbol	Parameter	Value	Unit
V_{IN} Low	Logic LOW level input voltage on all logic input pins except Switch-0	Min	-0.4 V
		Max	0.80 V
	Logic LOW level input voltage Switch-0	Min	-0.4 V
		Max	0.15 V
V_{IN} High	Logic HIGH level input voltage	Min	2.05 V
		Max	3.35 V
V_{OUT} Low	Logic LOW level output voltage	Max	0.4 V
V_{OUT} High	Logic HIGH level output voltage	Min	2.42 V
I_{GPIO}	Sink and source current	Max	4 mA

2.3.2.2 cB-OEMSPA331i/x products

Table 12: Input/output signals

Symbol	Parameter	Value	Unit
V_{IN} Low	Logic LOW level input voltage on all logic input pins except Switch-0	Min	-0.4 V
		Max	0.85 V
	Logic LOW level input voltage Switch-0	Min	-0.4 V
		Max	0.15 V
V_{IN} High	Logic HIGH level input voltage	Min	2.15 V
		Max	3.45 V
V_{OUT} Low	Logic LOW level output voltage	Max	0.4 V
V_{OUT} High	Logic HIGH level output voltage	Min	2.55 V
I_{GPIO}	Sink and source current	Max	4 mA

2.3.3 Environmental

Table 13: Temperatures characteristics

Parameter		Product Variant	Value	Unit		
Storage temperature	Min	All	-40	°C		
	Max	All	+125	°C		
Maximum operating temperature	Min	CB-OEMSPA311i/x-04	-30	°C		
		CB-OEMSPA331i/x-04				
		CB-OEMSPA311i/x-07				
		CB-OEMSPA331i/x-07				
	Max	CB-OEMSPA311i/x-06	-25	°C		
		CB-OEMSPA331i/x-06				
		CB-OEMSPA311i/x-04			+85	°C
		CB-OEMSPA331i/x-04				
CB-OEMSPA311i/x-06						
CB-OEMSPA331i/x-06						
Max	CB-OEMSPA311i/x-07	+80	°C			
	CB-OEMSPA331i/x-07					

2.4 Hardware Reset

A hardware $\overline{\text{RESET}}$ input is available on the J3, J6 and J7 connectors (see section 2.1). An external reset source must be open drain collector, see section A.2.4 for design examples. The $\overline{\text{RESET}}$ pin is internally pulled-up with 120k Ω .

2.5 Power Control

For more information about “Stop Mode” and other low power modes, see the Serial Port Adapter AT command Specification.

3 Operating Status

The module can be in different modes (see the Serial Port Adapter AT command Specification for more information about the modes) and the RED, GREEN and BLUE signals can be used to detect or indicating the status, see Table 14. The LED signals are active LOW.

Table 14: Signal states in different module modes

Serial Port Adapter Mode	Status	RGB LED Color	GREEN GPIO	BLUE GPIO	RED GPIO
Data mode	IDLE	Green	LOW	HIGH	HIGH
AT mode	IDLE	Orange	LOW	HIGH	LOW
Data mode, AT mode	CONNECTING*	Purple	HIGH	LOW	LOW
Data mode, AT mode	CONNECTED*	Blue	HIGH	LOW	HIGH

* On data activity the active LEDs flashes and will be HIGH for 50-100ms. For information on how to suppress the flashes see section A.2.3.1.

DTR signal can be set to indicate an active Bluetooth link. For more information see Serial Port Adapter AT command Specification.

4 Antennas

There are 2 different antenna options available:

- An internal surface mounted (SMD) antenna.
- An external antenna should be connected to a U.FL connector. Many different external antennas are available.

See section 5.1 for more information on antenna placement.

This chapter gives an overview of the different antenna options.

4.1 Surface Mounted Antenna (Internal)

The unit cannot be mounted in a metal-shielded enclosure with this antenna.

Part Number	OEMSPA 311i / 331i
Antenna name	Rufa 2.4 GHz
Manufacture	gigaAnt
Polarization	Linear
Gain (Max)	+0.5 dBi (mounted on this PCB)
Antenna size (LxWxH)	12.8x3.9x1.1 mm
Comment	The antenna gain is very dependent of the mounting of the module. See section 5.4 for mounting the module considering the antenna.

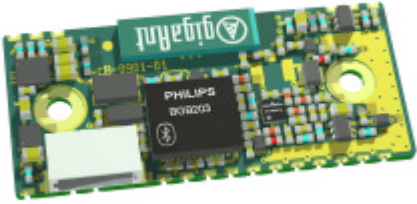

4.2 External antennas

The external antennas are connected to the board through a U.FL connector. Some of the antennas are connected directly to the U.FL connector of the board and some are connected using an SMA connected through a short U.FL to SMA adapter cable.

4.2.1 Antenna Accessories

Part Number	cB-ACC-18
Name	U.FL to SMA adapter cable
Connector	U.FL and SMA female
Cable length	120 mm
Cable loss	Less than 0.5dB

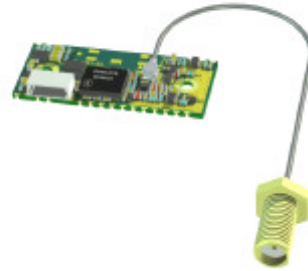

Comment	The SMA connector may be mounted in a panel. Not approved for use in the US and Canada.
---------	---

4.2.2 Antennas

Part Number	cB-ACC-16
Name	WCR-2400-SMA
Manufacture	Centurion
Type	½ wave dipole
Polarization	Vertical
Gain	+2.5dBi
Size	100 mm (Straight)
Connector	SMA male



Comment	To be mounted on the U.FL to SMA adapter cable.
---------	---

Approval	Not approved for use in the US and Canada.
----------	--

Part Number	cB-ACC-27
Name	WCR-2400-IP04
Manufacture	Centurion
Type	½ wave dipole
Polarization	Vertical
Gain	+2.0dBi
Size	108 mm (Straight)
Connector	U.FL connector



Comment	To be mounted on the U.FL connector on the PCB.
Approval	Approved for use in the US and Canada

Part Number	cB-ACC-17
Name	Reel planTec Bluetooth m70
Manufacture	Reel
Size (ØxH)	75x20 mm
Gain	+1dBi
Mounting	M16x13.6 mm
Cable length	3 m
Connector	SMA male
Other info	Waterproof (IP67)
Comment	To be mounted on the U.FL to SMA adapter cable.
Approval	Not approved for use in the US and Canada.



Part Number	cB-ACC-23
Name	Mobile Mark Stub
Manufacture	Mobile Mark Communications Antennas
Type	¼ wave dipole
Polarization	Vertical
Gain	0dBi
Connector	SMA male
Comment	To be mounted on the U.FL to SMA adapter cable



Approval Not approved for use in the US and Canada.

Part Number	cB-ACC-21
Name	Rugged SMA
Manufacture	Radiall/Larsen
Type	½ wave dipole
Polarization	Vertical
Gain	2dBi
Connector	SMA male



Comment To be mounted on the U.FL to SMA adapter cable

Approval Not approved for use in the US and Canada.

5 Mounting Information

5.1 Board Outlines

5.1.1 cB-0901

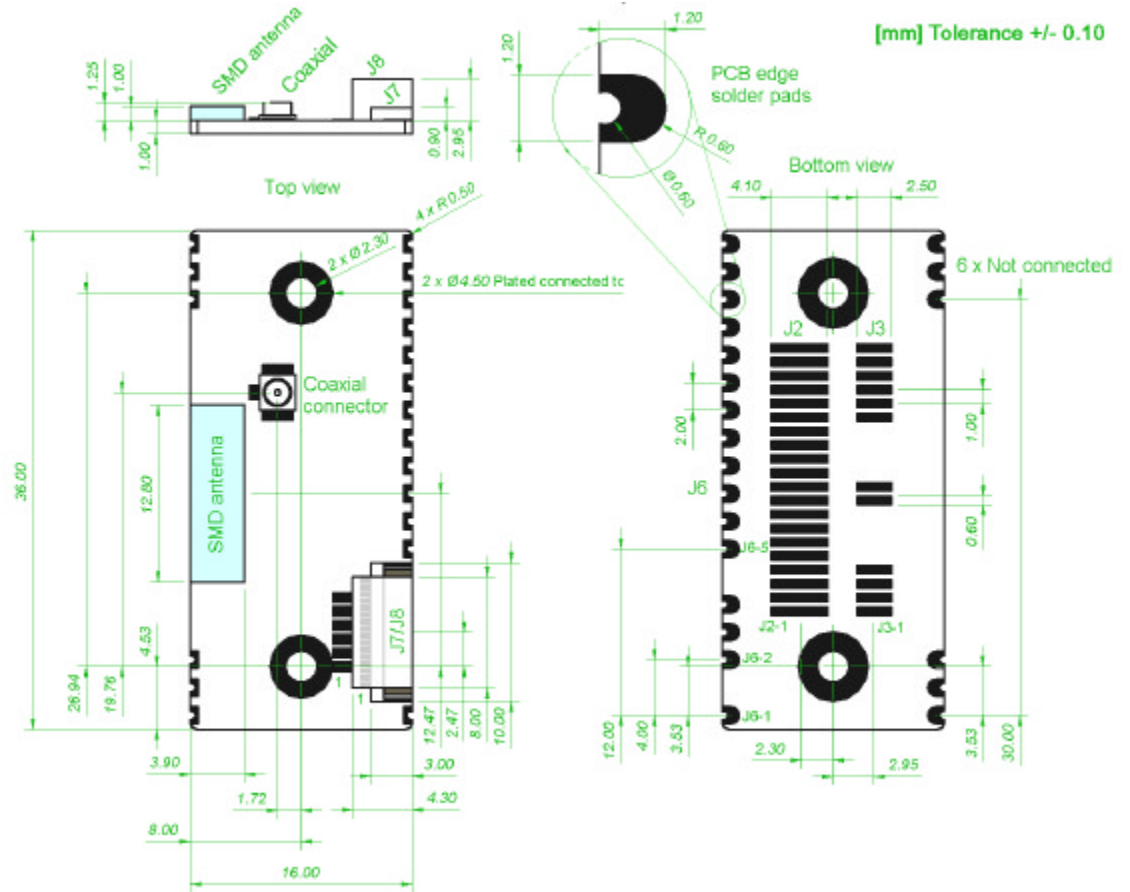

Figure 5: cB-0901 dimensions [mm]. The J2 pads are longer to fit both the single and double row ASP connectors (see section 5.2). Some of the not used pads of J3 are not visible

5.1.2 Mounting Holes

There are 2 x 2.3mm mounting holes on cB-0901. The reasons for the 2.3mm holes are that the threaded M2 holes on the single and double row connectors (see section 5.2.1) are not aligned. The outer tangents of the 2.3mm holes align the module if the single row connectors are used and the inner if double row connectors are used (see Figure 6).

Choose the outer tangent (CC distance 27.24mm) if the module is aligned and mounted with some other technique based on M2 screws (e.g. press-fit nuts), see Figure 7 and Figure 8.

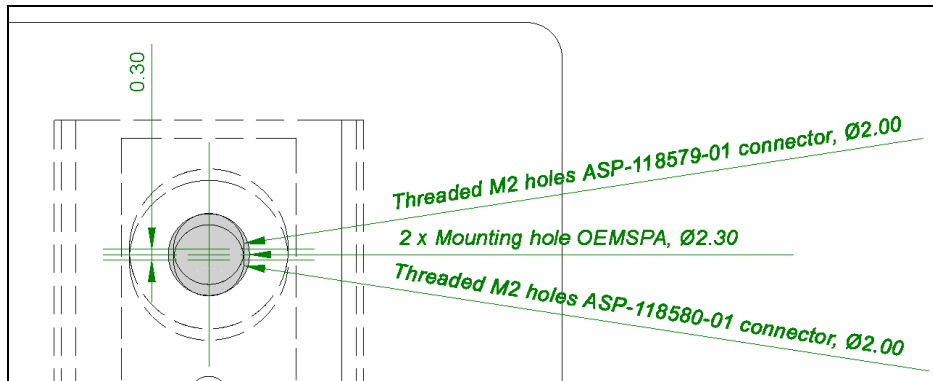

Figure 6: The 2.3mm mounting holes [mm]

5.2 Using the J2/J3 Board-to-Board Connectors

The board-to-board connector should be a 1mm pitch one-piece part connector. The recommended manufacture is Samtec with many connector options available; see section 5.2.1.1 and 5.2.1.2.

Chapter 2 contains more information about the connector and the electrical interface.

5.2.1 Suitable One-Piece Part Connectors

5.2.1.1 Single row connectors

These connectors are a single row connector and can be used if only J2 is needed.

This connector has a profile height of 1.65 mm and this has to be considered if components are to be mounted on the motherboard under the OEM Serial Port Adapter board.

There are alignment pins on the bottom side of the connector.

The connector is available with M2 threaded inserts that fit the mounting holes on the board (see section 5.1.2). You may screw the OEM Serial Port Adapter board directly into these inserts. If you want to have a tighter and more secure mounting, you may use longer screws and secure it using a nut on the backside of the motherboard.

Another way to mount the module is to use press-fit nuts on the motherboard and skip the M2 threads on the connector, see section 5.3 for more information about press-fit nuts.

Table 15: Single row connectors from Samtec.

Samtec order number	Quote number	Equivalent part	Package	Remark
ASP-118645-01	55392	SEI-120-02-GF-S-AB	Tube	Align pin on bottom side only
ASP-118645-02	55392	SEI-120-02-GF-S-AB-TR	Tape-n-Reel	Align pin on bottom side only
ASP-118579-01	55392	SEI-120-02-GF-S-M-AB	Tube	With M2 threaded inserts and align pin on bottom side only
ASP-118579-02	55392	SEI-120-02-GF-S-M-AB-TR	Tape-n-Reel	With M2 threaded inserts and align pin on bottom side only

NOTE:

When ordering connectors from Samtec or an official Samtec distributor, please use the ASP order number and refer to the connectBlue global quote number for best price. For technical questions regarding the Samtec connectors please contact connectBlue or Samtec at (Scandinavia@samtec.com).

See Figure 7 for more information about the connector and necessary measurements on the motherboard. The large mounting holes on the motherboard are designed for press-fit nuts and could be smaller if press-fit nuts are not used. The mounting holes are aligned with the outer tangent of the 2.3mm mounting holes of the module (see section 5.1.2).

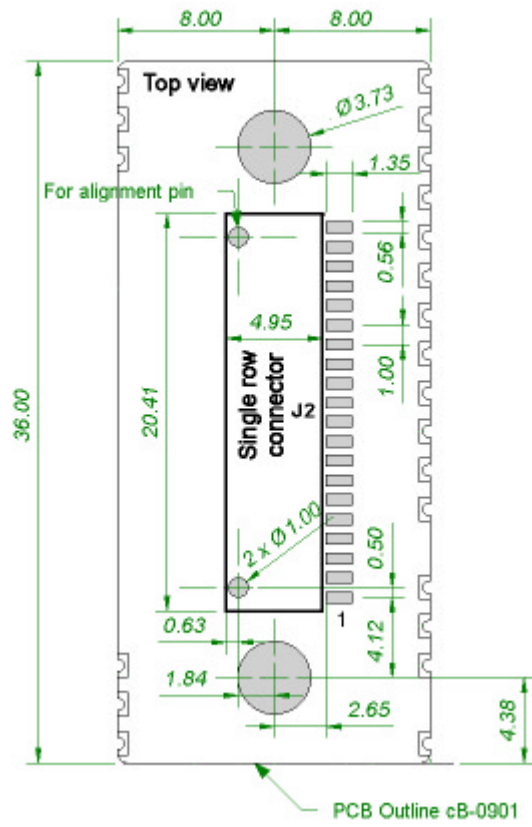

Figure 7: Host PCB layout [mm] for single row connector.

5.2.1.2 Double row connectors

This connector is a double row connector and can be used if both J2 and J3 are needed.

This connector has a height of 3.0mm and this has to be considered if components are to be mounted on the motherboard under the OEM Serial Port Adapter board. The connector is also available with a height of 6.0mm and 10.0mm (The FSI-120 serie from Samtec).

There are alignment pins on the bottom side of the connector.

The connector is available with M2 threaded inserts that fit the mounting holes on the board (see section 5.1.2). You may screw the OEM Serial Port Adapter board directly into these inserts. If you want to have a tighter and more secure mounting you may use longer screws and secure it using a nut on the backside of the motherboard.

Another way to mount the module is to use press-fit nuts on the motherboard and skip the M2 threads on the connector, see section 5.3 for more information about press-fit nuts.

Table 16: Double row connectors from Samtec.

Samtec order number	Quote number	Equivalent part	Package	Remark
REF-120021-01	55392	FSI-120-03-G-D-AB	Tube	Align pin on bottom side only
REF-120021-02	55392	FSI-120-03-G-D-AB-K-TR	Tape-n-Reel	Align pin on bottom side only
REF-120018-01	55392	FSI-120-03-G-D-M-AB	Tube	With M2 threaded inserts and align pin on bottom side only
REF-120018-02	55392	FSI-120-03-G-D-M-AB-K-TR	Tape-n-Reel	With M2 threaded inserts and align pin on bottom side only

NOTE:

When ordering connectors from Samtec or an official Samtec distributor, please use the REF order number and refer to the connectBlue global quote number for best price. For technical questions regarding the Samtec connectors please contact connectBlue or Samtec at (Scandinavia@samtec.com).

See Figure 8 for more information about the connector and necessary measurements on the motherboard. The large mounting holes on the motherboard are designed for press-fit nuts and could be smaller if press-fit nuts are not used (see section 5.1.2).

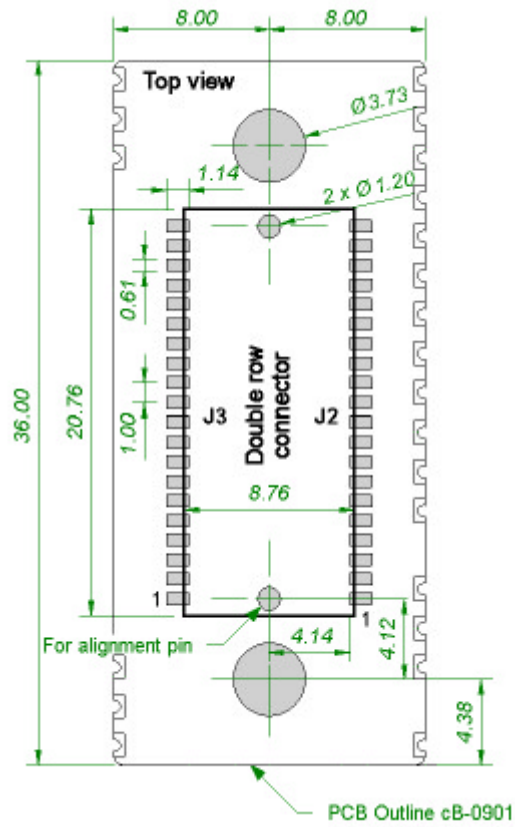

Figure 8: Host PCB layout [mm] for double row connector.

5.3 Using Press-Fit Nuts for Mounting the Module

A press-fit nut is pressed into the PCB from the bottom side with a special press tool. M2 sized press-fit nuts are suitable for the modules (see Figure 7 and Figure 8) and are manufactured by PEM Fastening Systems (www.pemnet.com), part no KFS2-M2 (see Figure 9). Be careful with the distance between the nuts regarding alignment, see section 5.1.2.

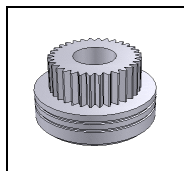

Figure 9: KFS2-M2 press-fit nut.

Spacer-pipes are recommended to use between the PCBs when press-fit nuts are used.

5.4 Using the J6 PCB solder pads on the edge

The CB-OEMSPA311i/x and CB-OEMSPA331i/x complies with the RoHS directive with lead free solder paste. The solder paste used is SAC 305 (NC254).

The host PCB footprint should not contain any traces or vias under the module except the pads interfacing the J6 pads to avoid contact with traces/vias on the module. The host pads which is soldered to the J6 pads should reach 0.5-1.0mm under the PCB and some mm outside the module. No other pads then the J6 should be soldered to the host PCB. See section 2.1.1 for more info about the J6 pads.

5.5 Antenna Issues

The unit cannot be mounted arbitrary, because of the radio communication. The unit with an internal surface mounted antenna (CB-OEMSPA311i and CB-OEMSPA331i) cannot be mounted in a metal enclosure, see Figure 10.

No metal casing or plastics using metal flakes should be used, avoid also metallic based paint or laquer. Keep a minimum clearance of 10mm between the antenna and the casing. Keep 10 mm free space from metal around the antenna including under and above.

If a metal enclosure is required, one of the external antenna options has to be used. See section 4.2 for more information on the antenna options available.

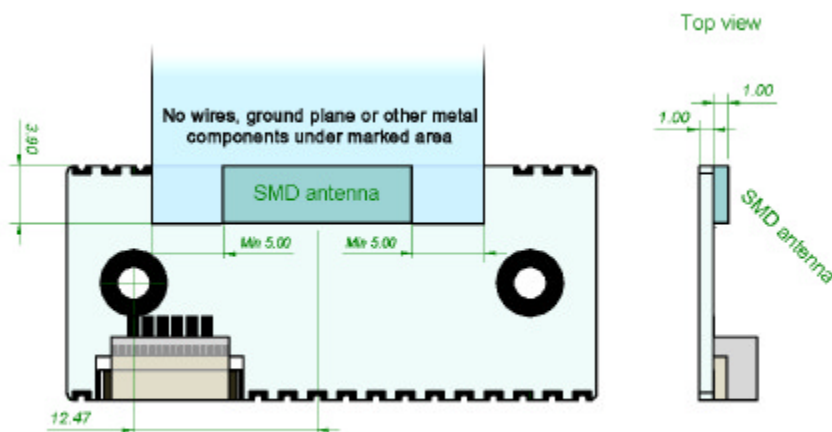

Figure 10: SMD Antenna restrictions.

6 Bluetooth Information

6.1 General information

In the tables below you can find information about Bluetooth properties. The cB-0901 module is available in two output power versions both Bluetooth Class 1. The output power of the cB-OEMSPA311i/x device is max +7dBm (5mW) and the output power of the cB-OEMSPA331i/x device is max +16.9dBm (49mW).

Table 17: Bluetooth information CB-OEMSPA-311i/x

Parameter	Data
Bluetooth radio	Philips BGB203
Bluetooth base band controller	Philips BGB203
RF output power	Class 1, max 7dBm (5mW)
Receive sensitive level	-90dBm
Receive input level (max)	+15dBm
Output frequency	2.402 –2.480 GHz, ISM band.
Bluetooth stack	Embedded host stack
Bluetooth qualification	2.0

Table 18: Bluetooth information CB-OEMSPA-331i/x)

Parameter	Data
Bluetooth radio	Phillips BGB203
Bluetooth base band controller	Phillips BGB203
Radio power amplifier	muRata MF2400PS-AL0909 (+20dB)
RF output power	Class 1, max 16.9dBm (49mW)
Receive sensitive level	-89dBm
Receive input level (max)	+16dBm
Output frequency	2.402 –2.480 GHz, ISM band.
Bluetooth stack	Embedded host stack
Bluetooth qualification	2.0

6.2 Bluetooth Qualification information



All products based on the PCB cB-0901-03 have been qualified according to the Bluetooth specification 2.0.

Table 19 - Bluetooth Qualification information

Module	Bluetooth specification	QPLN reference	Qualification date
cB-OEMSPA311i /x	2.0	B02598	2005-10-15
cB-OEMSPA331i/x	2.0	B02599	2005-10-15

The following Bluetooth profiles are supported (covered functionality):

- Generic Access Profile (GAP)
- Serial Port Profile (SPP)
- Dial-up Networking Profile (DUN GW, DUN DT)

When creating end products based on the Serial Port Adapter the following applies:

- The end product does not have to be re-qualified.
- The end product or the end product documentation based on:
 - cB-OEMSPA311i /x products shall make the following information available: "This product contains a Bluetooth qualified product QPLN B02598".
 - cB-OEMSPA331i /x products shall make the following information available: "This product contains a Bluetooth qualified product QPLN B02599".
- The Bluetooth Trademark may be placed on the end product (requires Bluetooth SIG membership, for more information see www.bluetooth.org).
- The Bluetooth Trademark may be used in material related to the end product (requires Bluetooth SIG membership, for more information see www.bluetooth.org).

For more information please contact connectBlue.

7 Regulatory Information

7.1 Declaration of Conformity



We, **connectBlue AB**, of
Norra Vallgatan 64 3V
SE-211 22 Malmö, Sweden

declare under our sole responsibility that our products:

cB-OEMSPA311i/x (cB-0052, cB-0054, cB-0055, cB-0056, cB-0058, cB-0059),
cB-OEMSPA331i/x (cB-0060, cB-0062, cB-0063, cB-0064, cB-0066, cB-0067),
cB-OEMHCI311i/x (cB-0086, cB-0087), cB-OEMHCI331i/x (cB-0088, cB-0089),
OEM Module Adapter III (cB-0068).

to which this declaration relates, conforms to the following product specifications:

R&TTE Directive 1999/5/EC

EN 300 328 V1.6.1 (2004-11)

EMC Directive: 89/336/EEC

EN 301 489-1 V1.4.1 (2002-08)

EN 301 489-17 V1.2.1 (2002-08)

EN 61000-6-2 (2001)

Safety Compliance

EN 60950-1:2001 and/or IEC 60950-1:2001 (1st Edition)

EN 60950-1/A11:2004 + Corrigendum:2004

Medical Electrical Equipment

IEC 60601-1-2 (2001)

24/09/2005 Malmö, Sweden

Mats Andersson

CTO of connectBlue AB

If a cB-OEMSPA331i/x is used within EU a notification must be made to each of the national authorities responsible for radio spectrum management of the intention to place radio equipment that uses frequency bands whose use is not harmonized throughout the EU, on its national market.

More information at: <http://europa.eu.int/comm/enterprise/rtte/gener.htm>

7.2 FCC, IC and Safety Compliance

See Table 1 for information about the different product variants.

7.2.1 Compliance for cB-0901-0301

7.2.1.1 FCC Statement for cB-0901-0301

This device complies with Part 15 of the FCC Rules. Operation is subject to the following two conditions: (1) this device may not cause harmful interference, and (2) this device must accept any interference received, including interference that may cause undesired operation.

NOTE: This equipment has been tested and found to comply with the limits for a Class B digital device, pursuant to Part 15 of the FCC Rules. These limits are designed to provide reasonable protection against harmful interference in a residential installation. This equipment generates, uses and can radiate radio frequency energy and, if not installed and used in accordance with the instructions, may cause harmful interference to radio communications. However, there is no guarantee that interference will not occur in a particular installation. If this equipment does cause harmful interference to radio or television reception, which can be determined by turning the equipment off and on, the user is encouraged to try to correct the interference by one or more of the following measures:

- Reorient or relocate the receiving antenna
- Increase the separation between the equipment and receiver
- Connect the equipment into an outlet on a circuit different from that to which the receiver is connected

Consult the dealer or an experienced radio/TV technician for help

7.2.1.1.1 Antenna

Our module type cB-0901-0301 is for OEM integrations only. The end-user product will be professionally installed in such a manner that only the authorized antennas are used.

7.2.1.1.2 Caution

Any changes or modifications NOT explicitly APPROVED by connectBlue AB could cause the module to cease to comply with FCC rules part 15, and thus void the user's authority to operate the equipment.

7.2.1.2 IC Compliance

Operation is subject to the following two conditions:

- (1) this device may not cause harmful interference, and
- (2) this device must accept any interference received,

including interference that may cause undesired operation.

This device has been designed to operate with an antenna having a maximum gain of 2.5 dBi.

Having a higher gain is strictly prohibited per regulations of Industry Canada. The required antenna impedance is 50 ohms.

To reduce potential radio interference to other users, the antenna type and its gain should be so chosen that the equivalent isotropically radiated power (EIRP) is not more than that required for successful communication.

The installer of this radio equipment must ensure that the antenna is located or pointed such that it does not emit RF field in excess of Health Canada limits for the general population; consult Safety Code 6, obtainable from Health Canada's website www.hc-sc.gc.ca/rpb.

7.2.1.3 Safety

The unit must be supplied by a limited power source in according to EN 60950-1.

7.2.1.4 Labeling Requirements for End Product

For an end product using the product cB-0901-0301 there must be a label containing, at least, the following information:

This device contains FCC ID: PVH090103S IC: 5325A-090103S

The label must be affixed on an exterior surface of the end product such that it will be visible upon inspection in compliance with the modular approval guidelines developed by the FCC.

Where the module will be installed in final products larger than 8 cm x 10 cm following statement has to be placed ONTO the device.

“This device complies with Part 15 of the FCC Rules.

Operation is subject to the following two conditions:

- (1) this device may not cause harmful interference, and
- (2) this device must accept any interference received, including interference that may cause undesired operation.”

In case, where the final product will be installed in locations where the end-consumer is not able to see the FCC ID and/or this statement, the FCC ID and the statement shall also be included in the end-product manual.

7.2.2 Compliance for cB-0901-0302

7.2.2.1 FCC Statement for cB-0901-0302

This device complies with Part 15 of the FCC Rules. Operation is subject to the following two conditions: (1) this device may not cause harmful interference, and (2) this device must accept any interference received, including interference that may cause undesired operation.

NOTE: This equipment has been tested and found to comply with the limits for a Class B digital device, pursuant to Part 15 of the FCC Rules. These limits are designed to provide reasonable protection against harmful interference in a residential installation. This equipment generates, uses and can radiate radio frequency energy and, if not installed and used in accordance with the instructions, may cause harmful interference to radio communications. However, there is no guarantee that interference will not occur in a particular installation. If this equipment does cause harmful interference to radio or television reception, which can be determined by turning the equipment off and on, the user is encouraged to try to correct the interference by one or more of the following measures:

- Reorient or relocate the receiving antenna
- Increase the separation between the equipment and receiver
- Connect the equipment into an outlet on a circuit different from that to which the receiver is connected

Consult the dealer or an experienced radio/TV technician for help

7.2.2.1.1 Antenna

Our module type cB-0901-0302 is for OEM integrations only. The end-user product will be professionally installed in such a manner that only the authorized antennas are used.

7.2.2.1.2 Caution

Any changes or modifications NOT explicitly APPROVED by connectBlue AB could cause the module to cease to comply with FCC rules part 15, and thus void the user's authority to operate the equipment.

7.2.2.2 IC Compliance

Operation is subject to the following two conditions:

- (1) this device may not cause harmful interference, and
- (2) this device must accept any interference received,

including interference that may cause undesired operation.

This device has been designed to operate with an antenna having a maximum gain of 9dBi.

Having a higher gain is strictly prohibited per regulations of Industry Canada. The required antenna impedance is 50 ohms.

To reduce potential radio interference to other users, the antenna type and its gain should be so chosen that the equivalent isotropically radiated power (EIRP) is not more than that required for successful communication.

The installer of this radio equipment must ensure that the antenna is located or pointed such that it does not emit RF field in excess of Health Canada limits for the general population; consult Safety Code 6, obtainable from Health Canada's website www.hc-sc.gc.ca/rpb.

7.2.2.3 Safety

The unit must be supplied by a limited power source in according to EN 60950-1.

7.2.2.4 Labeling Requirements for End Product

For an end product using the product cB-0901-0302 there must be a label containing, at least, the following information:

This device contains FCC ID: PVH090103L IC: 5325A-090103L

The label must be affixed on an exterior surface of the end product such that it will be visible upon inspection in compliance with the modular approval guidelines developed by the FCC.

Where the module will be installed in final products larger than 8 cm x 10 cm following statement has to be placed ONTO the device.

“This device complies with Part 15 of the FCC Rules.

Operation is subject to the following two conditions:

- (1) this device may not cause harmful interference, and
- (2) this device must accept any interference received, including interference that may cause undesired operation.”

In case, where the final product will be installed in locations where the end-consumer is not able to see the FCC ID and/or this statement, the FCC ID and the statement shall also be included in the end-product manual.

7.2.2.5 RF-exposure Statement for cB-0901-0302

This modular transmitter MUST have a separation distance of at least 20 cm between the antenna and the body of the user or nearby persons, excluding hands, wrists, feet, and ankles.

If the radio module is installed in a laptop display, transmission MUST be prevented if the lid is closed to ensure that the minimum distance of 20 cm between the user and the transmitting antenna is maintained.

Any notification to the end user of installation or removal instructions about the integrated radio module is NOT allowed.

7.3 UL listing information

If a customer intends to UL list a product including any of the Bluetooth modules based on the PCB cB-0901-03 this information is useful:

The printed circuit board if produced according to the following specification:

- UL recognized ZPMV2 min. 105 °C flame class V-0 or better.

7.4 Compliance with RoHS directive



All products based on the PCB cB-0901-03 are produced according to the RoHS (Restriction of the use of certain Hazardous substances in electrical and electronic equipment) directive and complies with the directive.

Appendix A - Application Notes

Usually only a subset of the available functionality is of interest to the designer. In addition, depending on the host system, the electrical interface can be designed in many ways. The designer can use the step-by-step guide in this chapter as an aid in the design process.

A.1 Step-by-Step Guide

Table 20: Step-by-step guide with Yes and No answers.

Question	Yes	No
Are you going to integrate the OEM Serial Port Adapter in a metal enclosure?	The internal antenna models cannot be used. Use the OEM-SPA311x or OEMSPA331x.	You are free to choose between the products. The internal antenna models are lower cost and are easier to design-in. However, an external antenna could give better range.
Do you wish to use logic level when communicating with the OEM Serial Port Adapter?	See section A.2.2.1 for electrical design.	See section A.2.2.2 - A.2.2.3 for electrical design.
Are you using a 5V host system?	See section A.2.1, Figure 12 for electrical design.	See section A.2.1, Figure 11 for electrical design.
Is low power consumption important?	The power consumption can be reduced by enabling the stop mode, see Table 10. The stop mode is controlled with the DSR pin, see section 2.5. The power consumption is optimized with 3.2-3.3 V supply voltage.	Go on to next point.
Do you wish to connect LEDs to the OEM Serial Port Adapter?	See section A.2.3 for design examples for connecting the LEDs.	Go on to next point.
Do you want to detect the status of the module with a controller?	See Chapter 3, Table 14 for status detection and section A.2.3 for electrical design.	Go on to next point.
Do you wish to utilize the restore switch?	See section A.2.3.3 for electrical design.	Go on to next point.
Do you wish to utilize the Function switch ("Connect on external signal")?	See section A.2.3.4 for electrical design.	Go on to next point.
Do you want to manually reset the module?	See section 0 for electrical design. Use a double row connector. See section 5.2.1.2.	

A.2 Design Examples

This section contains design examples for all interfaces on J2, J3, J6, J7 and J8. The connector type that suits a specific application depends on the needed signal and the preferred interface type (wires, flexfilm, board-to-board or SMD).

A.2.1 Logic Levels

A 3.0/3.3V host system can be connected directly to the logic level pins (BLUE, UART-TxD / UART-RxD etc). A serial 100Ω resistor shall be used (see Figure 11) for protection, see Table 12 for logic levels characteristics.

A 5V host system can easily be adjusted to the logic levels. A host system output signal can use a resistive divider (18k/22k) to adjust the levels. This is applicable for speeds up to 115.2kBits/s. The divider can be adjusted to 1.8k/2.2k and a logic buffer (74HCT08) for higher speeds (see Figure 12). The host system input pins could require a buffer (see Figure 12) depending on the logic level requirements (see Table 12).

The 74HCT08 gate is also available in a single gate package (74AHCT1G08).

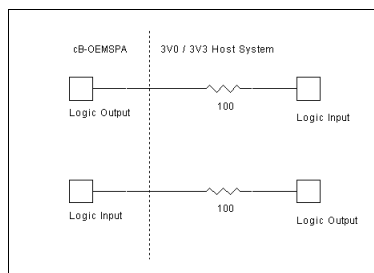

Figure 11: Logic levels interface to a 3/3.3V system. A protective 100Ω resistor is used.

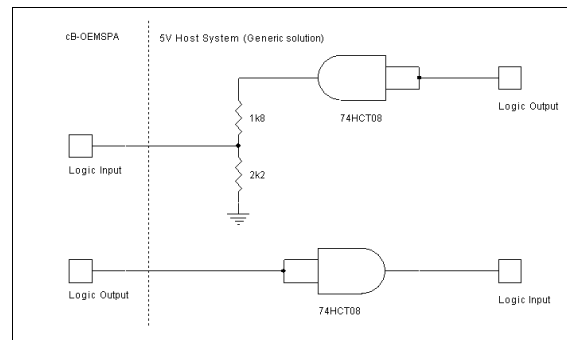

Figure 12: Interface example with logic levels to a 5V system.

A 5V system with open collector outputs is designed in Figure 13.

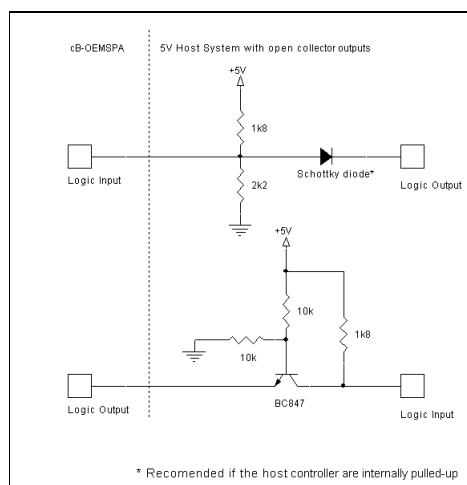

Figure 13: Open collector outputs.

A.2.2 Serial Interface

The serial interface of the module is Logic Level logic levels and the module can be connected to an external CPU (see section A.2.2.1).

An external driver is needed if the module should be on another physical interface like RS232 or RS422 (see section A.2.2.2 and A.2.2.3).

CTS (Clear To Send) and RTS (Request To Send) are used for hardware flow control.

DSR (Data Set Ready) can be used to make a connect attempt. See the Serial Port Adapter AT commands specification.

DTR (Data Terminal Ready) can be used to detect if the module is up and running and ready to receive data.

Note! The module must be configured to flow control none if hardware flow control is not used, see the Serial Port Adapter User Manual.

A.2.2.1 Logic level Mode

The serial UART interface can be used in a host controller application with a UART interface. The design of the interface depends on the power supply voltage of the host system; see Figure 14 for a 3.0/3.3V host system and Figure 15 for a 5V host system.

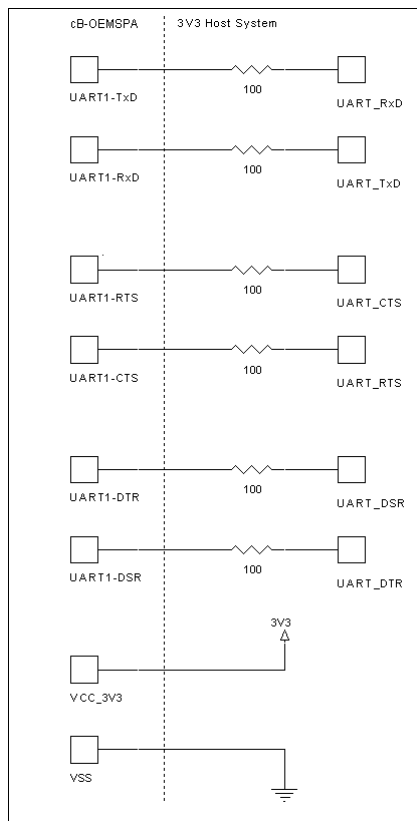

Figure 14: A complete UART interface with a 3.0/3.3V host system.

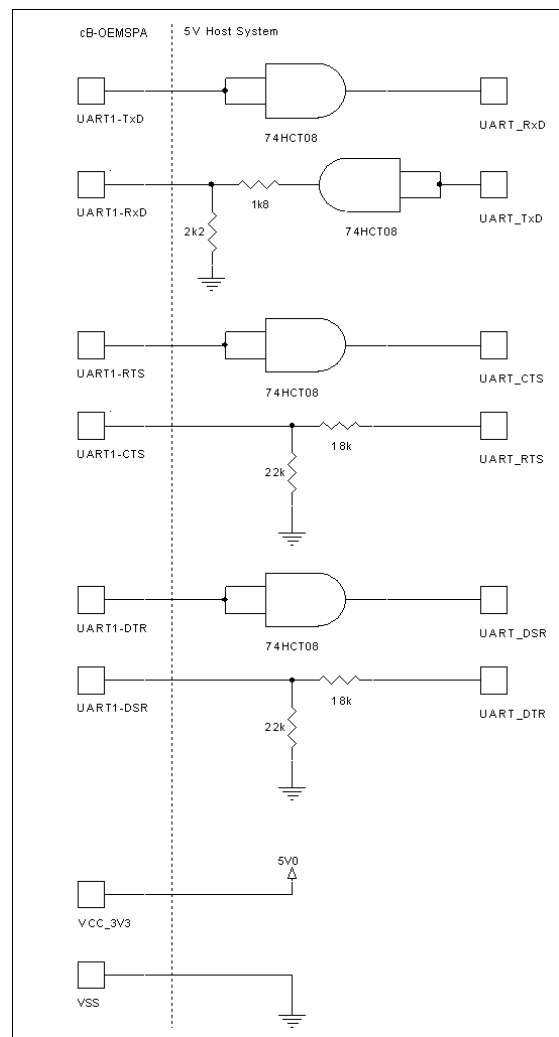

Figure 15: A complete UART interface with a 5V host system.

A.2.2.2 External RS232 driver

An external RS232 driver is needed if the module should have a RS232 serial interface. See Figure 16 for a complete design example that could be connected to the serial port of standard PC. Not used functionality can be left unconnected; see section A.2.2.

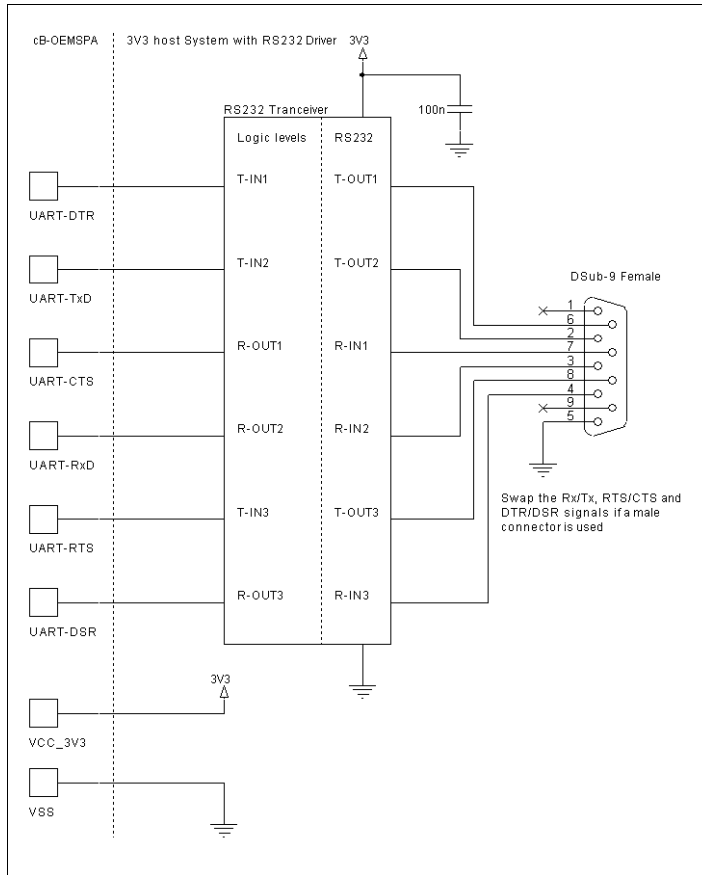

Figure 16: A complete RS232 interface.

A.2.2.3 External RS422 driver

An external RS422 driver could be used in a point-to-point (full duplex) application (see Figure 17).

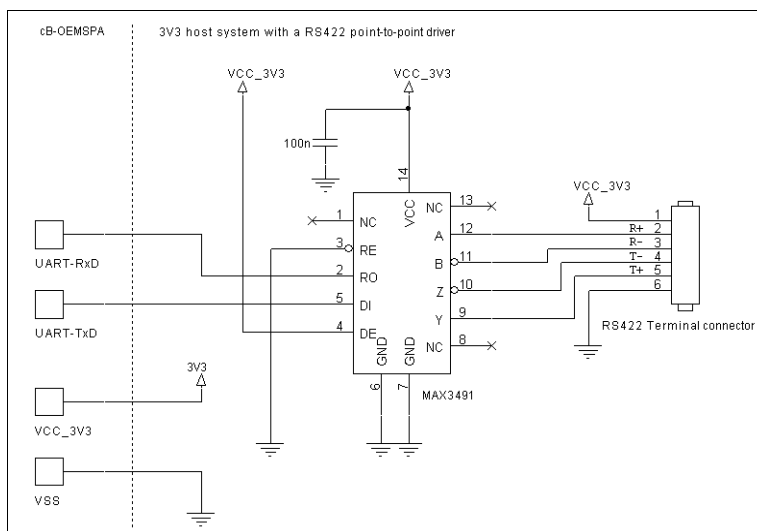

Figure 17: A complete RS422 interface.

A.2.3 LED and Switch Design

A.2.3.1 BLUE Signal

The BLUE logic LED signal is not multiplexed with any other functionality, which makes the design more straightforward (for more information see Figure 18). There are two important notes:

- A blue LED requires about 3.5V forward voltage drop (cannot be used in a 3.3V system).
- The BLUE signal can be used to detect if the module is connected or not. The BLUE signal flashes when the module is sending and receiving data (see Chapter 3, Table 14). See Figure 19 for an example on how to suppress the flashes.

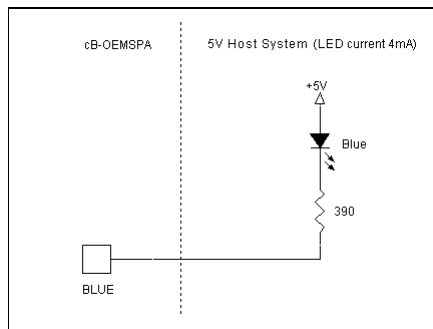

Figure 18: A blue LED can be connected directly to the module if the LED current is below 4mA. A high state (active low) makes the voltage drop over the LED to 2.2V. This is not enough to light the LED.

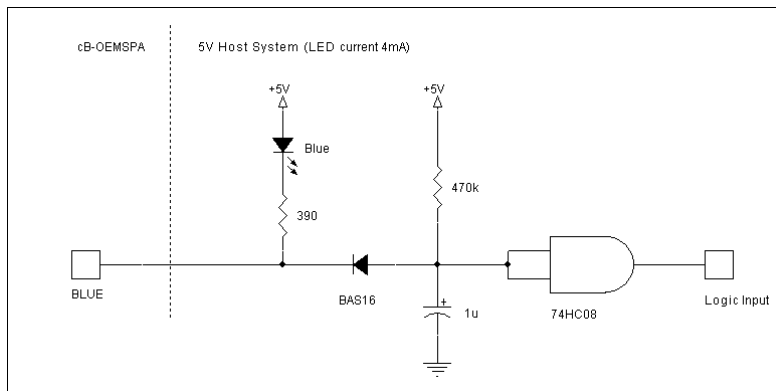

Figure 19: A Low pass filter and a 74HC08 suppress the flashes when the module is sending and receiving data. The Blue LED can be removed if not required. The values are not suited in all applications and need to be verified in a specific application.

A.2.3.2 RED

The RED logic LED signal is not multiplexed with any other functionality, which makes the design more straightforward. See Figure 20 for a 3.3V design.

In a 5V system the high state output (2.8V) from the module is not enough to turn off the LED so a 74HCT08 buffer can be used to raise the high level to 5V (see Figure 21).

The 74HCT08 gate is available in a single gate package (74AHCT1G08).

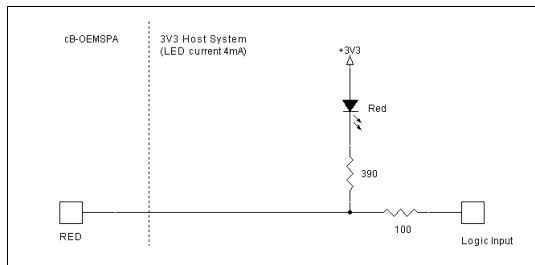

Figure 20: A red LED in a 3.3V host system. The status of the signal can also be used as input to a host controller.

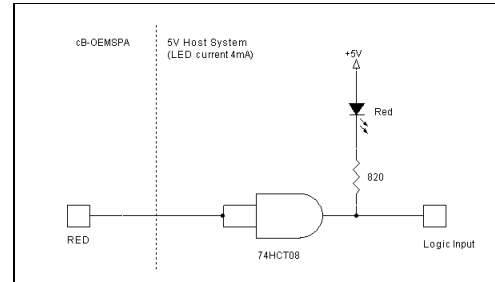

Figure 21: A red LED in a 5V host system. The status of the signal can also be used as input to a host controller.

The RED signal pin is also used to select Logic Level mode (instead of RS232) for connectBlue product with internal RS232 driver. The mode functionality is not applicable on cB-0901 because there is no internal RS232 driver available. To be compatible with these products check the datasheet about this signal.

A.2.3.3 GREEN/Switch-1 signal

The GREEN/Switch-1 signal is a multiplexed signal:

- **GREEN** - Logic green LED signal (see Chapter 3, Table 14). Becomes valid 500ms after start up.
- **Switch-1** - The module reads the status of the signal at startup to decide if the serial interface settings shall be restored (LOW) (see the Serial Port Adapter User Manual for more details). The input signal must be stable for the first 500ms after startup (after reset/power on reset).

The signal is internally pulled-up (50kΩ) to 3.0V for NOT restoring settings to default.

If a LED is used and a switch is required to be able to restore the settings, a high impedance buffer need to prevent the signal from being pulled-up via the LED. A 74HC08 logic gate can be used in a 3/3.3V system (see Figure 22) and a 74HCT08 logic gate in a 5V system (see Figure 23).

Both gates are available in a single gate package (74AHC1G08/74AHCT1G08).

Sometimes, over time, switch contacts can get an oxide layer. This may cause the closed switch resistance to become too high to sink the signal to logic LOW (the signal is internally pulled-up to 50kΩ). A design that prevents this can be found in Figure 27.

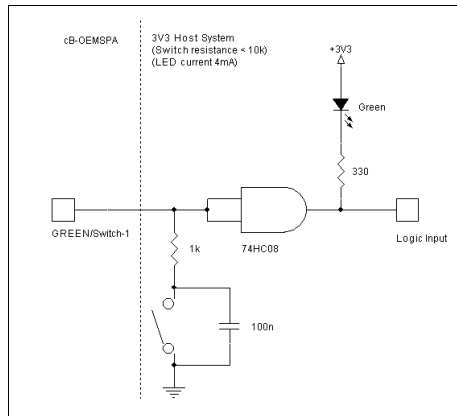

Figure 22: Switch-1 used together with a green LED in a 3.3V host system. The status of the signal can also be used as input to a host controller. Notice the 10kΩ serial resistor.

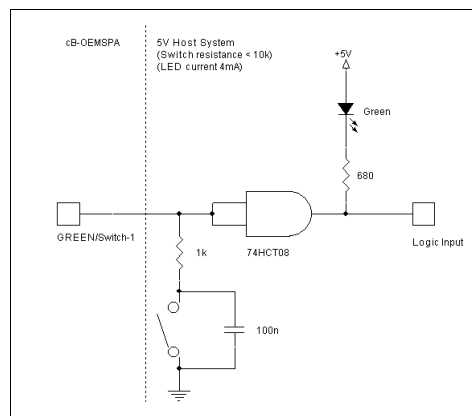

Figure 23: Switch-1 used together with a green LED in a 5V host system. The status of the signal can also be used as input to a host controller. Notice the 10kΩ serial resistor.

The buffer can be removed in a 3.3V system if no restore switch is required (see Figure 24).

In a 5V system the high state output (2.8V) from the module is not enough to turn off the LED, so a 74HCT08 buffer can be used to raise the high level to 5V (see Figure 25).

The 74HCT08 gate is also available in a single gate package (74AHCT1G08).

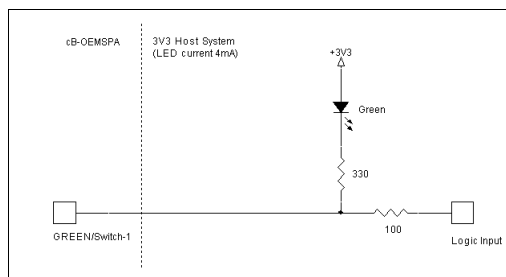

Figure 24: No restore switch used but a green LED in a 3.3V host system. The status of the signal can also be used as input to a host controller.

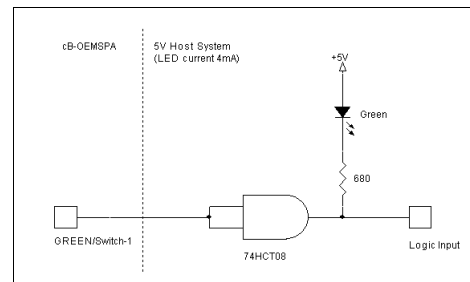

Figure 25: No restore switch used but a green LED in a 5V host system. The status of the signal can also be used as input to a host controller.

A serial resistor to the restore switch must be used to prevent a short circuit when the GREEN/Switch-1 pin is in output HIGH state and the switch is pressed (see Figure 26).

Sometimes, over time, switch contacts can get an oxide layer. This may cause the closed switch resistance to become too high to sink the signal to logic LOW (the signal is internally pulled-up to 50kΩ). A design that prevents this can be found in Figure 27.

The GREEN/Switch-1 pin can be left unconnected if none of its functionality is required.

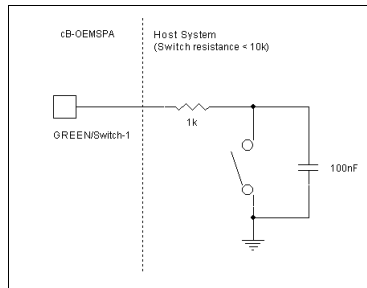

Figure 26: A low resistance restore switch used. Notice the 10kΩ serial resistor.

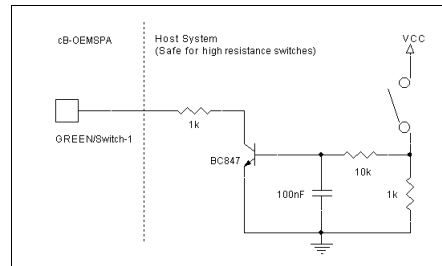

Figure 27: If the resistance in the switch is not guaranteed to be low enough, a safer design can be used. Notice the 10kΩ serial resistor.

A.2.3.4 Switch-0 Signal

Switch-0 is not multiplexed with other functionality and a switch is easily implemented (see Figure 28).

Sometimes, over time, switch contacts can get an oxide layer. This may cause the closed switch resistance to become too high to sink the signal to logic LOW (the signal is internally pulled-up to 50kΩ). A design that prevents this can be found in Figure 29.

The Switch-0 pin can be left unconnected if its functionality is not used.

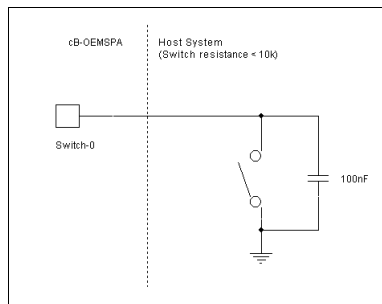

Figure 28: A low resistance function switch used.

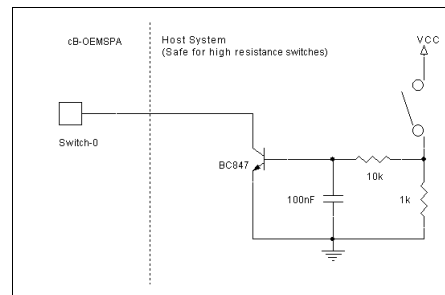

Figure 29: If the resistance in the switch is not guaranteed to be low enough, a safer design can be used.

A.2.4 Reset

The $\overline{\text{RESET}}$ pin can be connected to an external reset source, see Figure 30 for a switch example.

If the reset signal is connected to an output signal it must be an open drain collector, see Figure 31. Notice the capacitive load on the $\overline{\text{RESET}}$ pin in Table 12, section 2.3.

The $\overline{\text{RESET}}$ pin can be left unconnected if not used.

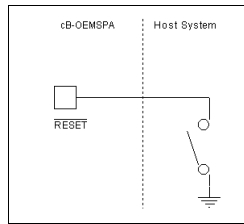

Figure 30: A reset switch.

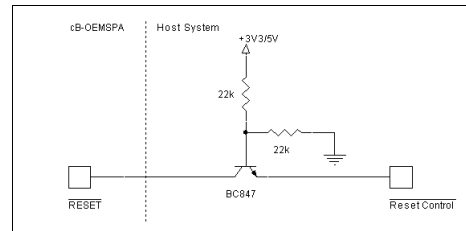

Figure 31: Design of an open collector reset from an active high output.

A.2.5 A Complete 5V Host System Interface

This is a complete 5V host system interface example with an RGB LED and two switches (except the serial interface, see section A.2.2 for information). The design is based on the LM339 Quad OP-amp instead of logic gates.

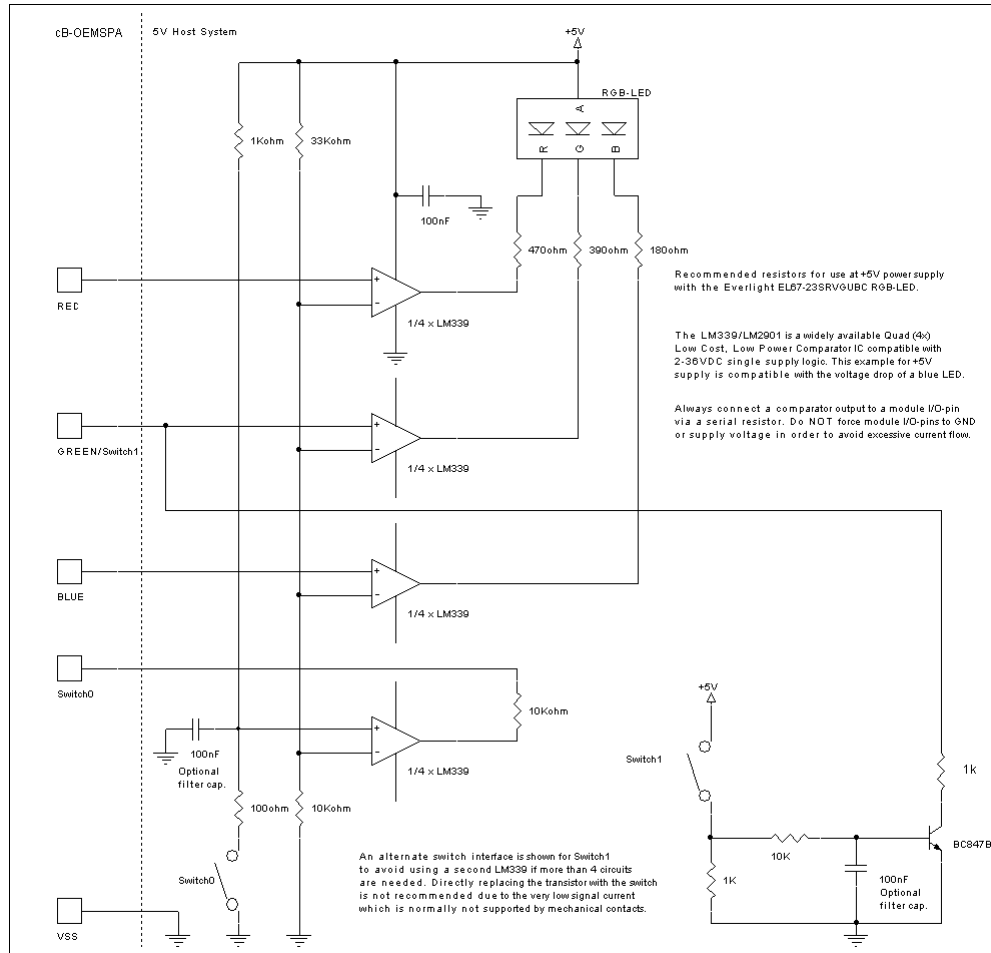

Figure 32: A complete 5V host interface with operational amplifier