

OEM Serial Port Adapter™

cB-0905

Electrical & Mechanical Datasheet

connectBlue

**OEM Serial Port Adapter™
cB-0905**

Electrical & Mechanical Datasheet

Copyright © 2006 connectBlue AB.

The contents of this document can be changed by connectBlue AB without prior notice and do not constitute any binding undertakings from connectBlue AB. connectBlue AB is not responsible under any circumstances for direct, indirect, unexpected damage or consequent damage that is caused by this document.

All rights reserved.

Release: 2006-08

Document version: 1

Document number: cBProduct-0605-05

Printed in Sweden.

Trademarks

Registered trademarks from other companies are: Bluetooth is a trademark owned by the Bluetooth SIG, Inc., Microsoft™, Windows™, Windows NT™, Windows 2000™, Windows CE™, Windows ME™, are registered trademarks from Microsoft Corporation.

Contents

1	Introduction	5
1.1	Related Documents	5
1.2	Product Variants	6
1.3	cB-0905	7
1.4	Block Diagram cB-0905	8
2	Electrical Interface and Connectors	9
2.1	Pin Numbering	10
2.2	Pin Description	11
2.3	Characteristics	14
2.4	Hardware Reset	17
2.5	Power Control	17
3	Operating Status	18
4	Antennas	19
4.1	Surface Mounted Antenna (Internal)	19
4.2	External antennas	20
5	Mounting Information	23
5.1	Board Outlines	23
5.2	Using the J2/J3 Board-to-Board Connectors	25
5.3	Using Press-Fit Nuts for Mounting the Module	29
5.4	Antenna Issues	29
6	Bluetooth Information	30
6.1	General information	30
6.2	Bluetooth Qualification information	31
7	Regulatory Information	32
7.1	Declaration of Conformity	32
7.2	Safety Compliance	33
7.3	FCC and IC Compliance	33
7.4	UL listing information	35
7.5	Compliance with RoHS directive	35
8	Guidelines for Efficient and Safe Use	36
8.1	General	36
8.2	Product Care	36
8.3	Radio Frequency Exposure	36
8.4	Electronic Equipment	37
8.5	Potentially Explosive Atmospheres	37
8.6	Power Supply	37
Appendix A -	Application Notes	38
A.1	Step-by-Step Guide	38
A.2	Design Examples	39

1 Introduction

1.1 Related Documents

There are some documents related to the Serial Port Adapter:

- The **Serial Port Adapter AT Commands** document contains a description of the AT commands supported in the Serial Port Adapter. It also contains information on how to use the AT commands to create Bluetooth applications.
- The **OEM Serial Port Adapter Electrical & Mechanical Datasheet** (this document) contains important information about the OEM Serial Port Adapter. Read this document if you are using the OEM Serial Port Adapter.

1.2 Product Variants

This Electrical and Mechanical datasheet contains information about the 4 variants of OEM Serial Port Adapters based on the PCB cB-0905. This document makes references to the OEM Module ID, not the Product Name (see Table 1).

Table 1: Product variants

	Product Name	OEM Module ID / FCC ID	Bluetooth Type	Description
Class 1 TBDdBm Internal antenna	CB-OEMSPA333i-02	cB-0099-01 PVH090502L	Class 1 / TBDdBm TBDmW	OEM Serial Port Adapter 333i with internal antenna, 2mm pin connector
	CB-OEMSPA333i-04	cB-0100-01 PVH090502L	Class 1 / TBDdBm TBDmW	OEM Serial Port Adapter 333i with internal antenna, no connectors
Class 1 TBDdBm External antenna	CB-OEMSPA333x-02	cB-0101-01 PVH090502L	Class 1 / TBDdBm TBDmW	OEM Serial Port Adapter 333x with external antenna, 2mm pin connector
	CB-OEMSPA333x-04	cB-0102-01 PVH090502L	Class 1 / TBDdBm TBDmW	OEM Serial Port Adapter 333x with external antenna, no connectors

1.3 cB-0905

cB-0905 is a small size Bluetooth module based on the Phillips BGB204 system in package (SiP). The Bluetooth host and the SPA application are running on a separate Host CPU. The Bluetooth signal is amplified with a power amplifier (PA) built on discrete components, which is covered by a shield box. The modules are available in many variants with different antenna / connectors. See Picture 1 - Picture 2 for some of the available models. All models are described in Table 1.

The cB-0905 has an RS232 interface and is fully compatible with the connectBlue 2:nd Generation Class 1 Serial Port Adapter.

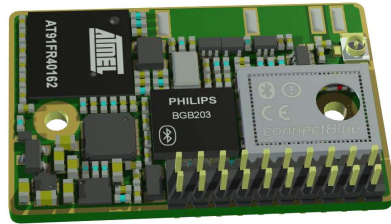

Picture 1: CB-OEMSPA333x-02 OEM Serial Port Adapter long range with external antenna and 2mm pin connector



Picture 2: CB-OEMSPA333i-04 OEM Serial Port Adapter long range with internal antenna and no connectors

1.4 Block Diagram cB-0905

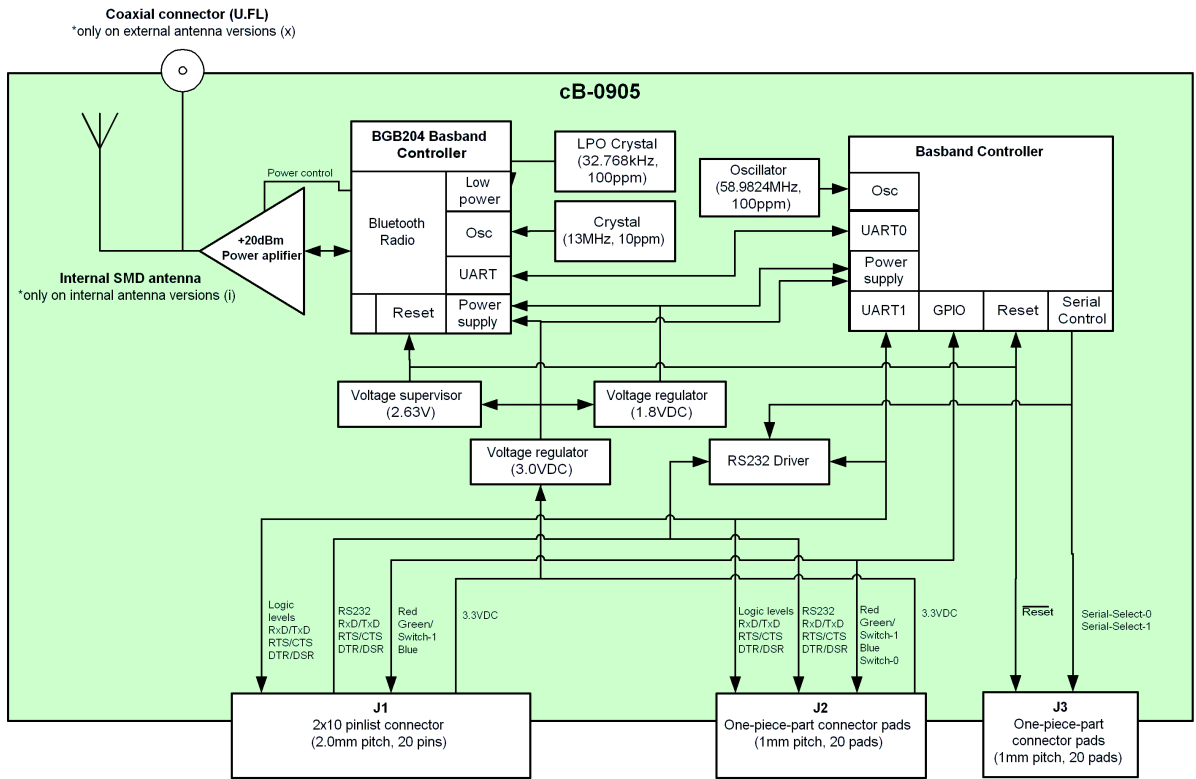

Figure 1: Block diagram of cB-0905

2 Electrical Interface and Connectors

This section describes the signals available on the module interface connectors.

There are two ways to connect to the OEM Serial Port Adapter:

- Via the 2x10-pin 2mm header connector J1 (see Picture 3).
- Via the 2x20-pin 1mm pitch board-to-board (one piece part) connectors, J2 through J3. The J2 to J3 connectors on the OEM Serial Port Adapter exist on the module only as a mating PCB-layout pattern (see Picture 4). See Section 5.2 for more information.

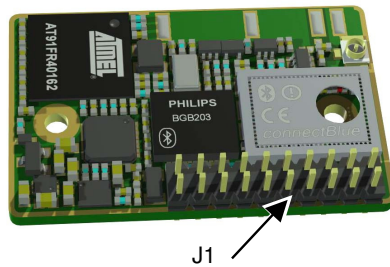

Picture 3: 2x20 2mm pinlist connector, J1.

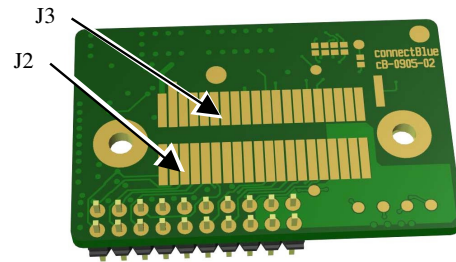

Picture 4: J2 to J3 are available on cB-0905.

2.1 Pin Numbering

2.1.1 J2 and J3

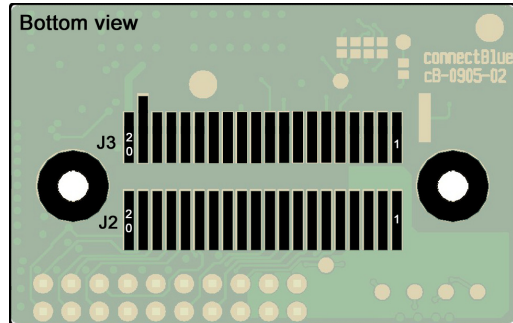

Figure 2: Bottom view of the PCB with the pinning of the J2 and J3 pads connector.

2.1.2 Pinlist

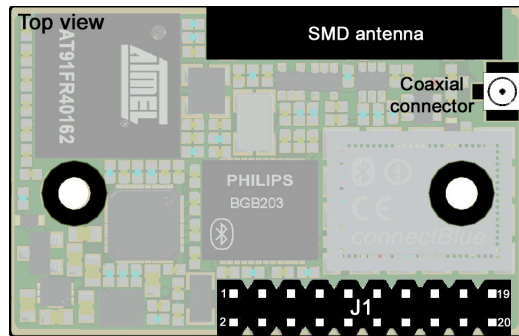

Figure 3: Top view of the PCB with the pinning of the J1 connector.

2.2 Pin Description

2.2.1 J1 & J2 Connector

Table 2: Signals on J1 and J2.

J1&J2 Pin Nr	Pin Name	Signal Name	Signal Level	Type	Description
1-2	VSS	Ground	Ground		GND
3-4	VCC_3V3	Power	3.3V		3.3 – 6.0 VDC for CB-OEMSPA332 modules
5	RS232-CTS	Clear To Send	RS232	In	Hardware flow control
6	RS232-TxD	Transmit Data	RS232	Out	
7	RS232-RTS	Request To Send	RS232	Out	Hardware flow control
8	RS232-RxD	Receive Data	RS232	In	
9	RS232-DTR	Data Terminal Ready	RS232	Out	
10	RS232-DSR	Data Set Ready	RS232	In	Also used to control the power saving mode "stop mode". See section 2.5 for more information.
11	RED/Mode	Red LED output	CMOS	In/Out	This signal is multiplexed: RED: Logic Red LED Signal (see Chapter 3, Table 8). Pin is used as input for approximately 500ms at startup. Mode: The level on this pin during power up selects RS232 (High) or logic (Low) level UART-communication. The Mode pin is only valid during the first 500ms after startup and cannot be changed during operation. The Mode pin is internally pulled up i.e. RS232 mode is the default setting. Recommended value of the pull-down resistor is 1kΩ**. See section A.2.3.2 for design examples.

J1&J2 Pin Nr	Pin Name	Signal Name	Signal Level	Type	Description
12	Switch-0	Function switch	CMOS	In	Used for the "Connect on external signal" function, see the Serial Port Adapter AT command Specification for more information on the Function switch. See section A.2.3.4 for design examples.
13	GREEN/ Switch-1	Green LED output and Restore switch	CMOS	In/Out	This signal is multiplexed: GREEN: Logic Green LED Signal (see Chapter 3, Table 8). Not valid until 500ms after startup. Switch-1: If the level on this pin is pulled-down with 1kΩ** the units goes back to default serial settings. The "Restore Default" input is only active during the first 500ms after startup. See the Serial Port Adapter AT command Specification for more information on the Restore switch. See section A.2.3.3 for design examples.
14	BLUE	Blue LED output	CMOS	Out	Logic Blue LED Signal (see Chapter 3, Table 8). Note: Signal will flicker at data transmission. See section A.2.3.1 for design examples.
15	UART-CTS*	Clear To Send	CMOS	In	Hardware flow control.
16	UART-TxD*	Transmit Data	CMOS	Out	
17	UART-RTS*	Request To Send	CMOS	Out	Hardware flow control.
18	UART-RxD*	Receive Data	CMOS	In	
19	UART-DTR*	Data Terminal Ready	CMOS	Out	
20	UART-DSR*	Data Set Ready	CMOS	In	

* All signals are logic level UART signals (typically 0 - 3VDC)

** Use 1kΩ as pull-down which is different to previous product generations from connectBlue

2.2.2 J3 Connector

Table 3: Signals on J3

J3 Pin Nr	Pin Name	Signal Name	Signal Level	Type	Description
1-8					Reserved, do not connect.
9	SerialSelect-0	Serial Select 0	CMOS	Out	Control signal for external serial transceivers. See section A.2.2.4 for more info.
10	SerialSelect-1	Serial Select 1	CMOS	Out	Control signal for external serial transceivers. See section A.2.2.4 for more info.
11-18					Reserved, do not connect.
19	<u>RESET</u>	Hardware reset	CMOS	In	Active low. Must be open drain collector. See section 2.4 for design examples.
20					Reserved, do not connect.

2.3 Characteristics

The cB-0905 module has a linear power supply, which means that the current is constant if the voltage supply is changed. See Table 5.

For more information about low power modes see Serial Port Adapter AT commands Specification.

2.3.1 Power supply

NOTE: Read the safety notes in section 7.2 before using the modules.

Table 4: Power supply

Symbol	Parameter		Value	Unit
VCC_3V3	Power supply (Unregulated*)	Min	3.3	VDC
		Max	6.0	VDC

* The module is equipped with an internal linear voltage regulator.

Table 5: Current consumption

Symbol	Mode			Value	Unit
I_{cc} @ VCC_3V3 = 3.3V	Not connected	Stop mode not enabled.	Average	TBD	mA
			Peak	TBD	mA
	Not connected, stop mode enabled	Not connectable	Average	TBD	mA
			Peak	TBD	mA
		Connectable	Average	TBD	mA
			Peak	TBD	mA
	Connectable, discoverable		Average	TBD	mA
			Peak	TBD	mA
	Connected	Idle or Receiving	Average	TBD	mA
			Peak	TBD	mA
		Transmitting @115.2kbit/s	Average	TBD	mA
			Peak	TBD	mA
		Inquiry	Average	TBD	mA
			Peak	TBD	mA
$I_{RS232\ Output}^1$	RS232	Average	7	mA	
$R_{RS232\ load}^2$	RS232	Typ	20	k Ω	

¹ RS232 output signals TxD, RTS, DTR loaded with 3k Ω . Not included in I_{cc} , very dependent on the load.

² Internal load on each RS232 input pin.

2.3.2 Input/Output signals

Table 6: Input/output signals

Symbol	Parameter		Value	Unit
V_{IN} Low	Logic LOW level input voltage	Min	-0.3	V
		Max	0.8	V
V_{IN} High	Logic HIGH level input voltage	Min	2.0	V
		Max	3.2	V
V_{OUT} Low	Logic LOW level output voltage	Max	0.4	V
V_{OUT} High	Logic HIGH level output voltage	Min	2.5	V
I_{GPIO}^3	Sink and source current	Max	2*	mA
RESET _{TH}	V_{IN} Reset threshold	Typ	2.63	V
	V_{IN} Reset Active Timeout Period	Typ	240	ms

³ Different compared to previous products from connectBlue

2.3.3 Environmental

Table 7: Temperatures characteristics

Parameter		Value	Unit
Storage temperature	Min	-40	°C
	Max	+125	°C
Maximum operating temperature	Min	-30	°C
	Max	+85	°C

2.4 Hardware Reset

A hardware $\overline{\text{RESET}}$ input is available on the J3 connector (see section 2.1). An external reset source must be open drain collector, see section A.2.4 for design examples. The $\overline{\text{RESET}}$ pin is internally pulled-up with 120k Ω .

2.5 Power Control

For more information about "Stop Mode" and other low power modes, see the Serial Port Adapter AT command Specification.

3 Operating Status

The module can be in different modes (see the Serial Port Adapter AT command Specification for more information about the modes) and the RED, GREEN and BLUE signals can be used to detect or indicating the status, see Table 8. The LED signals are active LOW.

Table 8: Signal states in different module modes

Serial Port Adapter Mode	Status	RGB LED Color	GREEN GPIO	BLUE GPIO	RED GPIO
Data mode	IDLE	Green	LOW	HIGH	HIGH
AT mode	IDLE	Orange	LOW	HIGH	LOW
Data mode, AT mode	CONNECTING*	Purple	HIGH	LOW	LOW
Data mode, AT mode	CONNECTED*	Blue	HIGH	LOW	HIGH

* On data activity the active LEDs flashes and will be HIGH for 50-100ms. For information on how to suppress the flashes see section A.2.3.1.

DTR signal can be set to indicate an active Bluetooth link. For more information see Serial Port Adapter AT command Specification.

4 Antennas

There are 2 different antenna options available:

- An internal surface mounted (SMD) antenna.
- An external antenna should be connected to a U.FL connector. Many different external antennas are available.

See section 5.1 for more information on antenna placement.

This chapter gives an overview of the different antenna options.

4.1 Surface Mounted Antenna (Internal)

The unit cannot be mounted in a metal-shielded enclosure with this antenna.

Part Number	OEMSPA 312i / 332i
Antenna name	Mica 2.4 GHz
Manufacture	gigaAnt
Polarization	Linear
Gain	+2.5dBi
Antenna size (LxWxH)	20.5x3.6x3.3 mm
Comment	The antenna gain is dependent of the mounting of the module. See section 5.4 for mounting the module considering the antenna.

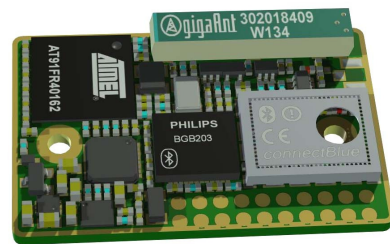

4.2 External antennas

The external antennas are connected to the board through a U.FL connector. Some of the antennas are connected directly to the U.FL connector of the board and some are connected using an SMA connected through a short U.FL to SMA adapter cable.

4.2.1 Antenna Accessories

Part Number	cB-ACC-18
Name	U.FL to SMA adapter cable
Connector	U.FL and SMA female
Cable length	120 mm
Cable loss	Less than 0.5dB

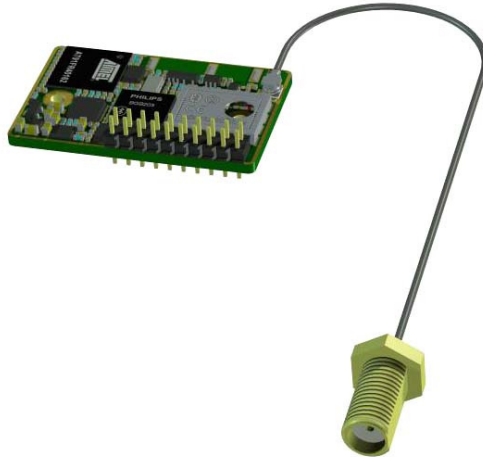

Comment The SMA connector may be mounted in a panel. Not approved for use in the US and Canada.

4.2.2 Antennas

Part Number	cB-ACC-16
Name	WCR-2400-SMA
Manufacture	Centurion
Type	½ wave dipole
Polarization	Vertical
Gain	+2.5dBi
Size	100 mm (Straight)
Connector	SMA male



Comment To be mounted on the U.FL to SMA adapter cable.

Approval Not approved for use in the US and Canada.

Part Number	cB-ACC-27
Name	WCR-2400-IP04
Manufacture	Centurion
Type	½ wave dipole
Polarization	Vertical
Gain	+2.0dBi
Size	108 mm (Straight)
Connector	U.FL connector
Comment	To be mounted on the U.FL connector on the PCB.
Approval	Approved for use in the US and Canada



Part Number	cB-ACC-17
Name	Reel planTec Blue-tooth m70
Manufacture	Reel
Size (ØxH)	75x20 mm
Gain	+1dBi
Mounting	M16x13.6 mm
Cable length	3 m
Connector	SMA male
Other info	Waterproof (IP67)
Comment	To be mounted on the U.FL to SMA adapter cable.
Approval	Not approved for use in the US and Canada.



Part Number	cB-ACC-19
Name	Microblue CAP24235
Manufacture	Centurion
Type	Microstrip
Polarization	Linear
Gain	+1.5dBi
Size	21x60 mm
Cable length	200 mm
Connector	U.FL
Comment	Connected directly to the U.FL connector on OEM board.
Approval	Approved for use in the US and Canada

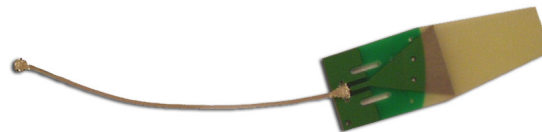

Part Number	cB-ACC-23
Name	Mobile Mark Stub
Manufacture	Mobile Mark Communications Antennas
Type	¼ wave dipole
Polarization	Vertical
Gain	0dBi
Connector	SMA male
Comment	To be mounted on the U.FL to SMA adapter cable
Approval	Not approved for use in the US and Canada.



Part Number	cB-ACC-21
Name	Rugged SMA
Manufacture	Radiall/Larsen
Type	½ wave dipole
Polarization	Vertical
Gain	2dBi
Connector	SMA male
Comment	To be mounted on the U.FL to SMA adapter cable
Approval	Not approved for use in the US and Canada.



5 Mounting Information

5.1 Board Outlines

5.1.1 cB-0905

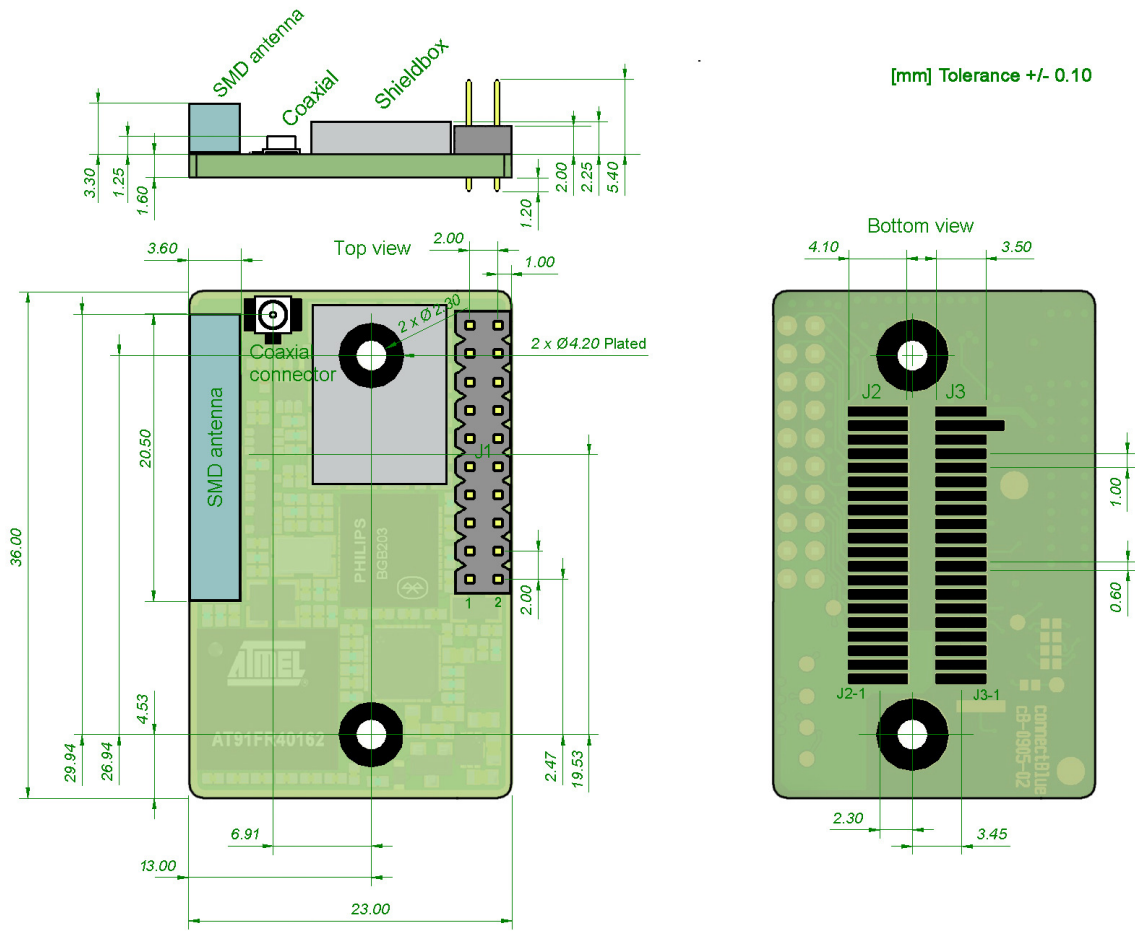

Figure 4: cB-0905 dimensions [mm]. The J2 pads are longer to fit both the single and double row connectors (see section 5.2).

5.1.2 Mounting Holes

There are 2 x 2.3mm mounting holes on cB-0905. The reasons for the 2.3mm holes are that the threaded M2 holes on the single and double row connectors (see section 5.2.1) are not aligned. The outer tangents of the 2.3mm holes align the module if the single row connectors are used and the inner if double row connectors are used (see Figure 5).

Choose the outer tangent (CC distance 27.24mm) if the module is aligned and mounted with some other technique based on M2 screws (e.g. press-fit nuts), see Figure 6 and Figure 7.

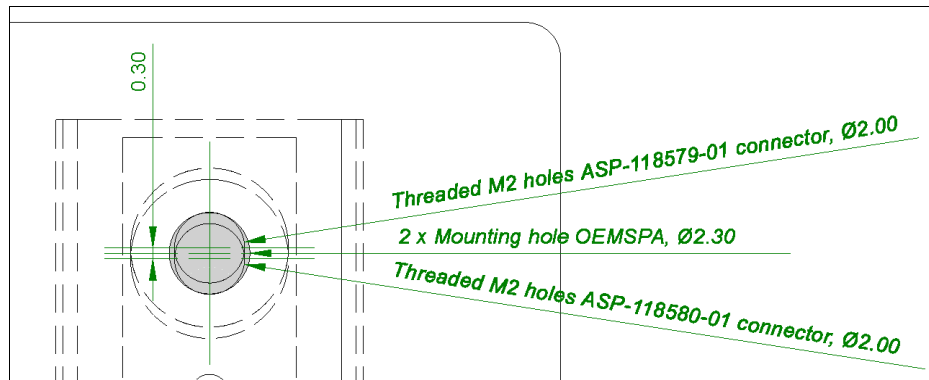

Figure 5: The 2.3mm mounting holes [mm]

5.2 Using the J2/J3 Board-to-Board Connectors

The board-to-board connector should be a 1mm pitch one-piece part connector. The recommended manufacture is Samtec with many connector options available; see section 5.2.1.1 and 5.2.1.2.

Chapter 2 contains more information about the connector and the electrical interface.

5.2.1 Suitable One-Piece Part Connectors

5.2.1.1 Single row connectors

These connectors are a single row connector and can be used if only J2 is needed.

This connector has a profile height of 1.65 mm and this has to be considered if components are to be mounted on the motherboard under the OEM Serial Port Adapter board.

There are alignment pins on the bottom side of the connector.

The connector is available with M2 threaded inserts that fit the mounting holes on the board (see section 5.1.2). You may screw the OEM Serial Port Adapter board directly into these inserts. If you want to have a tighter and more secure mounting, you may use longer screws and secure it using a nut on the backside of the motherboard.

Another way to mount the module is to use press-fit nuts on the motherboard and skip the M2 threads on the connector, see section 5.3 for more information about press-fit nuts.

Table 9: Single row connectors from Samtec.

Samtec order number	Quote number	Equivalent part	Package	Remark
ASP-118645-01	55392	SEI-120-02-GF-S-AB	Tube	Align pin on bottom side only
ASP-118645-02	55392	SEI-120-02-GF-S-AB-TR	Tape-n-Reel	Align pin on bottom side only
ASP-118579-01	55392	SEI-120-02-GF-S-M-AB	Tube	With M2 threaded inserts and align pin on bottom side only
ASP-118579-02	55392	SEI-120-02-GF-S-M-AB-TR	Tape-n-Reel	With M2 threaded inserts and align pin on bottom side only

NOTE:

When ordering connectors from Samtec or an official Samtec distributor, please use the ASP order number and refer to the connectBlue global quote number for best price. For technical questions regarding the Samtec connectors please contact connectBlue or Samtec at (Scandinavia@samtec.com).

See Figure 6 for more information about the connector and necessary measurements on the motherboard. The large mounting holes on the motherboard are designed for press-fit nuts and could be smaller if press-fit nuts are not used. The mounting holes are aligned with the outer tangent of the 2.3mm mounting holes of the module (see section 5.1.2).

5.2.1.2 Double row connectors

This connector is a double row connector and can be used if both J2 and J3 are needed.

This connector has a height of 3.0mm and this has to be considered if components are to be mounted on the motherboard under the OEM Serial Port Adapter board. The connector is also available with a height of 6.0mm and 10.0mm (The FSI-120 serie from Samtec).

There are alignment pins on the bottom side of the connector.

The connector is available with M2 threaded inserts that fit the mounting holes on the board (see section 5.1.2). You may screw the OEM Serial Port Adapter board directly into these inserts. If you want to have a tighter and more secure mounting you may use longer screws and secure it using a nut on the backside of the motherboard.

Another way to mount the module is to use press-fit nuts on the motherboard and skip the M2 threads on the connector, see section 5.3 for more information about press-fit nuts.

Table 10: Double row connectors from Samtec.

Samtec order number	Quote number	Equivalent part	Package	Remark
REF-120021-01	55392	FSI-120-03-G-D-AB	Tube	Align pin on bottom side only
REF-120021-02	55392	FSI-120-03-G-D-AB-K-TR	Tape-n-Reel	Align pin on bottom side only
REF-120018-01	55392	FSI-120-03-G-D-M-AB	Tube	With M2 threaded inserts and align pin on bottom side only
REF-120018-02	55392	FSI-120-03-G-D-M-AB-K-TR	Tape-n-Reel	With M2 threaded inserts and align pin on bottom side only

NOTE:

When ordering connectors from Samtec or an official Samtec distributor, please use the REF order number and refer to the connectBlue global quote number for best price. For technical questions regarding the Samtec connectors please contact connectBlue or Samtec at (Scandinavia@samtec.com).

See Figure 7 for more information about the connector and necessary measurements on the motherboard. The large mounting holes on the motherboard are designed for press-fit nuts and could be smaller if press-fit nuts are not used (see section 5.1.2).

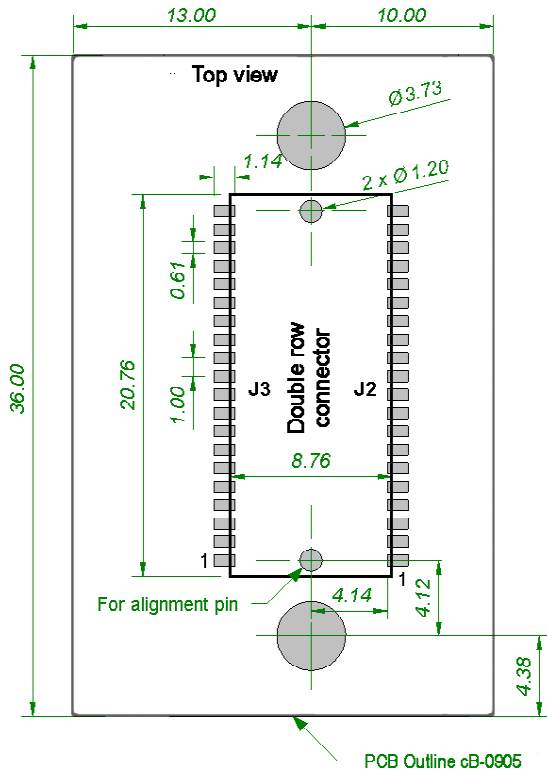

Figure 7: Host PCB layout [mm] for double row connector.

5.3 Using Press-Fit Nuts for Mounting the Module

A press-fit nut is pressed into the PCB from the bottom side with a special press tool. M2 sized press-fit nuts are suitable for the modules (see Figure 6 and Figure 7) and are manufactured by PEM Fastening Systems (www.pemnet.com), part no KFS2-M2 (see Figure 8). Be careful with the distance between the nuts regarding alignment, see section 5.1.2.

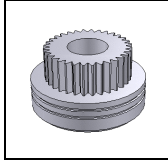

Figure 8: KFS2-M2 press-fit nut.

Spacer-pipes are recommended to use between the PCBs when press-fit nuts are used.

5.4 Antenna Issues

The unit cannot be mounted arbitrary, because of the radio communication. The unit with an internal surface mounted antenna (CB-OEMSPA333i) cannot be mounted in a metal enclosure.

No metal casing or plastics using metal flakes should be used, avoid also metallic based paint or lacquer. Keep a minimum clearance of 10mm between the antenna and the casing. Keep 10 mm free space from metal around the antenna.

If a metal enclosure is required, one of the external antenna options has to be used. See section 4.2 for more information on the antenna options available.

6 Bluetooth Information

6.1 General information

In the tables below you can find information about Bluetooth properties. The output power of the cB-OEMSPA333i/x device is max TBD dBm (TBDmW).

Table 11: Bluetooth information CB-OEMSPA-333i/x

Parameter	Data
Bluetooth radio	Phillips BGB204
Bluetooth base band controller	Phillips BGB204
Radio power amplifier	muRata MF2400PS-AL0909 (+20dB)
RF output power	Class 1, max TBDdBm (TBDmW)
Receive sensitive level	-83 dBm
Receive input level (max)	+16dBm
Output frequency	2.402 –2.480 GHz, ISM band.
Bluetooth stack	Embedded host stack
Bluetooth qualification	2.0

6.2 Bluetooth Qualification information



All products based on the PCB cB-0905-02 have been qualified according to the Bluetooth specification 2.0.

Table 12 - Bluetooth Qualification information

Module	Bluetooth specification	QPLN reference	Qualification date
cB-OEMSPA333i/x	2.0	TBD	TBD

The following Bluetooth profiles are supported (covered functionality):

- Generic Access Profile (GAP)
- Serial Port Profile (SPP)
- Dial-up Networking Profile (DUN GW, DUN DT)

When creating end products based on the Serial Port Adapter the following applies:

- The end product does not have to be re-qualified.
 - The end product or the end product documentation based on cB-OEMSPA333i /x products shall make the following information available: "This product contains a Bluetooth qualified product QPLN TBD".
- The Bluetooth Trademark may be placed on the end product (requires Bluetooth SIG membership, for more information see www.bluetooth.org).
- The Bluetooth Trademark may be used in material related to the end product (requires Bluetooth SIG membership, for more information see www.bluetooth.org).

For more information please contact connectBlue.

7 Regulatory Information

7.1 Declaration of Conformity



We, **connectBlue AB**, of
Norra Vallgatan 64 3V
SE-211 22 Malmö, Sweden

declare under our sole responsibility that our products:

cB-OEMSPA333i/x (cB-0099, cB-0100, cB-0101, cB-0102)

OEM Module Adapter III (cB-0068).

to which this declaration relates, conforms to the following product specifications:

R&TTE Directive 1999/5/EC

EN 300 328 V1.6.1 (2004-11)

EMC Directive: 89/336/EEC

EN 301 489-1 V1.4.1 (2002-08)

EN 301 489-17 V1.2.1 (2002-08)

EN 61000-6-2 (2001)

Safety Compliance

EN 60950-1:2001 and/or IEC 60950-1:2001 (1st Edition)

EN 60950-1/A11:2004 + Corrigendum:2004

Medical Electrical Equipment

IEC 60601-1-2 (2001)

17/07/2006 Malmö, Sweden

Mats Andersson

CTO of connectBlue AB

If a cB-OEMSPA333i/x is used within EU a notification must be made to each of the national authorities responsible for radio spectrum management of the intention to place radio equipment that uses frequency bands whose use is not harmonized throughout the EU, on its national market.

More information at: <http://europa.eu.int/comm/enterprise/rtte/gener.htm>

7.2 Safety Compliance

In order to fulfill the safety standard EN 60950-1 the unit must be supplied by a limited power source.

7.3 FCC and IC Compliance

See Table 1 for information about the different product variants.

7.3.1 Compliance for cB-0905-0202

7.3.1.1 FCC Statement for cB-0905-0202

This device complies with Part 15 of the FCC Rules. Operation is subject to the following two conditions: (1) this device may not cause harmful interference, and (2) this device must accept any interference received, including interference that may cause undesired operation.

NOTE: This equipment has been tested and found to comply with the limits for a Class B digital device, pursuant to Part 15 of the FCC Rules. These limits are designed to provide reasonable protection against harmful interference in a residential installation. This equipment generates, uses and can radiate radio frequency energy and, if not installed and used in accordance with the instructions, may cause harmful interference to radio communications. However, there is no guarantee that interference will not occur in a particular installation. If this equipment does cause harmful interference to radio or television reception, which can be determined by turning the equipment off and on, the user is encouraged to try to correct the interference by one or more of the following measures:

- Reorient or relocate the receiving antenna
- Increase the separation between the equipment and receiver
- Connect the equipment into an outlet on a circuit different from that to which the receiver is connected

Consult the dealer or an experienced radio/TV technician for help

7.3.1.1.1 Antenna

Our module type cB-0905-0202 is for OEM integrations only. The end-user product will be professionally installed in such a manner that only the authorized antennas are used.

7.3.1.1.2 Caution

Any changes or modifications NOT explicitly APPROVED by connectBlue AB could cause the module to cease to comply with FCC rules part 15, and thus void the user's authority to operate the equipment.

7.3.1.2 IC Compliance

Operation is subject to the following two conditions:

(1) this device may not cause harmful interference, and
(2) this device must accept any interference received,
including interference that may cause undesired operation.

List of approved antennas:

- 2.4 GHz Flying Lead Straight Antenna IHF-242
- WCR-2400-IP04
- MicroBlue CAP24235
- NanoBlue-IP04

-
- 2.4 GHz Mica SMD Antenna (Internal)

This device has been designed to operate with an antenna having a maximum gain of +2,5dBi. Antennas not included in this list or having a gain greater than +2.5dBi are strictly prohibited for use with this device. The required antenna impedance is 50 ohms.

To reduce potential radio interference to other users, the antenna type and its gain should be so chosen that the equivalent isotropically radiated power (EIRP) is not more than that required for successful communication.

The installer of this radio equipment must ensure that the antenna is located or pointed such that it does not emit RF field in excess of Health Canada limits for the general population; consult Safety Code 6, obtainable from Health Canada's website www.hc-sc.gc.ca/rpb.

7.3.1.3 Labeling Requirements for End Product

For an end product using the product cB-0905-0202 there must be a label containing, at least, the following information:

This device contains FCC ID: PVH090502L IC: 5325A-090502L

The label must be affixed on an exterior surface of the end product such that it will be visible upon inspection in compliance with the modular approval guidelines developed by the FCC.

Where the module will be installed in final products larger than 8 cm x 10 cm following statement has to be placed ONTO the device.

"This device complies with Part 15 of the FCC Rules.

Operation is subject to the following two conditions:

- (1) this device may not cause harmful interference, and
- (2) this device must accept any interference received, including interference that may cause undesired operation."

In case, where the final product will be installed in locations where the end-consumer is not able to see the FCC ID and/or this statement, the FCC ID and the statement shall also be included in the end-product manual.

7.3.1.4 RF-exposure Statement for cB-0905-0202

This modular transmitter **MUST** have a separation distance of at least 20 cm between the antenna and the body of the user or nearby persons, excluding hands, wrists, feet, and ankles.

If the radio module is installed in a laptop display, transmission **MUST** be prevented if the lid is closed to ensure that the minimum distance of 20 cm between the user and the transmitting antenna is maintained.

Any notification to the end user of installation or removal instructions about the integrated radio module is **NOT** allowed.

7.4 UL listing information

If a customer intends to UL list a product including any of the Bluetooth modules based on the PCB cB-0905-02 this information is useful:

The printed circuit board if produced according to the following specification:

- UL recognized ZPMV2 min. 105 °C flame class V-0 or better.

7.5 Compliance with RoHS directive



All products based on the PCB cB-0905-02 are produced according to the RoHS (Restriction of the use of certain Hazardous substances in electrical and electronic equipment) directive and complies with the directive.

8 Guidelines for Efficient and Safe Use

8.1 General

Read this information before using your OEM Serial Port Adapter.

For any exceptions, due to national requirements or limitations, when using your OEM Serial Port Adapter, please visit www.bluetooth.org.

Note: Changes or modifications to the product not expressly approved by connectBlue AB will void the user's authority to operate the equipment.

8.2 Product Care

- Do not expose your product to liquid or moisture.
- Do not expose you product to extreme hot or cold temperature (see Section 2.3.3 for further information)
- Do not expose your product to lit candles, cigarettes, cigars, open flames, etc.
- Do not drop, throw or try to bend your product since rough treatment could damage your product.
- Do not attempt to disassemble your product. Doing so will void warranty. The product does not contain consumer serviceable or replaceable components. Service should only be performed by connectBlue AB.
- Do not paint your product as the paint could prevent normal use.
- If you will not be using your product for a while, store it in a place that is dry, free from damp, dust and extreme heat and cold.

8.3 Radio Frequency Exposure

The OEM Serial Port Adapter contains a small radio transmitter and receiver. During communication with other Bluetooth products the OEM Serial Port Adapter receives and transmits radio frequency (RF) electromagnetic fields (microwaves) in the frequency range 2400 to 2500 MHz. The output power of the radio transmitter is very low.

When using the OEM Serial Port Adapter, you will be exposed to some of the transmitted RF energy. This exposure is well below the prescribed limits in all national and international RF safety standards and regulations.

8.4 Electronic Equipment

Most modern electronic equipment, for example, in hospitals and cars, is shielded from RF energy. However, certain electronic equipment is not. Therefore:

Note: This equipment emits RF energy in the ISM (Industrial, Scientific, Medical) band. Please insure that all medical devices used in proximity to this device meet appropriate susceptibility specifications for this type of RF energy.

8.5 Potentially Explosive Atmospheres

Turn off your electronic device before entering an area with potentially explosive atmosphere. It is rare, but your electronic device could generate sparks. Sparks in such areas could cause an explosion or fire resulting in bodily injury or even death.

Areas with a potentially explosive atmosphere are often, but not always, clearly marked. They include fuelling areas, such as petrol station, below deck on boats, fuel or chemical transfer or storage facilities, and areas where the air contains chemicals or particles, such as grain, dust, or metal powders.

8.6 Power Supply

The OEM Serial Port Adapter must be supplied by a limited power source according to EN 60950-1.

- Connect your power supply only to designated power-sources as marked on the product.
- Make sure all cords and cable are positioned so that they will not be stepped on, tripped over or otherwise subject to damage or stress.
- To reduce risk of electric shock, unplug the unit from any power source before attempting to clean it.

Appendix A - Application Notes

Usually only a subset of the available functionality is of interest to the designer. In addition, depending on the host system, the electrical interface can be designed in many ways. The designer can use the step-by-step guide in this chapter as an aid in the design process.

A.1 Step-by-Step Guide

Table 13: Step-by-step guide with Yes and No answers.

Question	Yes	No
Are you going to integrate the OEM Serial Port Adapter in a metal enclosure?	The internal antenna models cannot be used. Use the OEM-SPA333x.	You are free to choose between the products. The internal antenna models are lower cost and are easier to design-in. However, an external antenna could give better range.
Do you wish to use logic level when communicating with the OEM Serial Port Adapter?	See section A.2.2.1 for electrical design.	Go on to next point.
Do you want to use RS232 as the physical serial interface?	See section A.2.2.2 for electrical design.	Go on to next point.
Do you want to use RS485 or RS422 as the physical serial interface?	See section A.2.2.3 - A.2.2.4 for electrical design.	Go on to next point.
Are you using a 5V host system?	See section A.2.1, Figure 10 for electrical design.	See section A.2.1, Figure 9 for electrical design.
Is low power consumption important?	The power consumption can be reduced by enabling the stop mode, see Table 5. The stop mode is controlled with the DSR pin, see section 2.5. The power consumption is optimized with 3.3 V supply voltage.	Go on to next point.
Do you wish to connect LEDs to the OEM Serial Port Adapter?	See section A.2.3 for design examples for connecting the LEDs.	Go on to next point.
Do you want to detect the status of the module with a controller?	See Chapter 3, Table 8 for status detection and section A.2.3 for electrical design.	Go on to next point.
Do you wish to utilize the restore switch?	See section A.2.3.3 for electrical design.	Go on to next point.
Do you wish to utilize the Function switch ("Connect on external signal")?	See section A.2.3.4 for electrical design.	Go on to next point.
Do you want to manually reset the module?	See section A.2.4 for electrical design. Use a double row connector. See section 5.2.1.2.	

A.2 Design Examples

This section contains design examples for all interfaces on J1, J2 and J3. The connector type that suits a specific application depends on the needed signal and the preferred interface type.

A.2.1 Logic Levels

A 3.0/3.3V host system can be connected directly to the logic level pins (BLUE, UART-TxD / UART-RxD etc). A serial 100Ω resistor shall be used (see Figure 9) for protection, see Table 6 for logic levels characteristics.

A 5V host system can easily be adjusted to the logic levels. A host system output signal can use a resistive divider (18k/22k) to adjust the levels. This is applicable for speeds up to 115.2kBits/s. The divider can be adjusted to 1.8k/2.2k and a logic buffer (74HCT08) for higher speeds (see Figure 10). The host system input pins could require a buffer (see Figure 10) depending on the logic level requirements (see Table 6).

The 74HCT08 gate is also available in a single gate package (74AHCT1G08).

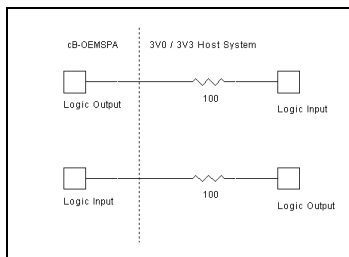

Figure 9: Logic levels interface to a 3/3.3V system. A protective 100Ω resistor is used.

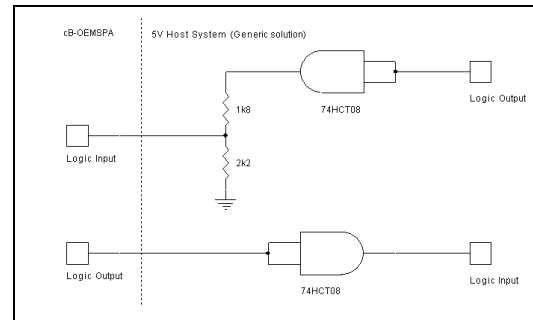

Figure 10: Interface example with logic levels to a 5V system.

A 5V system with open collector outputs is designed in Figure 11.

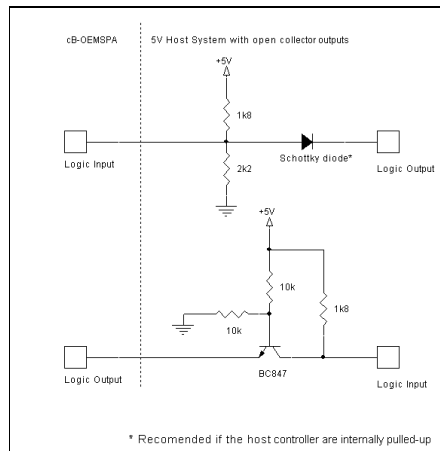

Figure 11: Open collector outputs.

A.2.2 Serial Interface

The serial interface can operate in RS232 or Logic level mode, see section A.2.3.2.

The Logic level mode could be used if the module is connected to an external CPU or if the physical interface should be another than the internal RS232 likes RS422 (see section A.2.2.3).

The signal excluding the RxD and TxD signals available on the serial interface are:

CTS (Clear To Send) and RTS (Request To Send) are used for hardware flow control.

DSR (Data Set Ready) can be used to make a connect attempt. See the Serial Port Adapter AT commands specification.

DTR (Data Terminal Ready) can be used to detect if the module is up and running and ready to receive data.

Note! The module must be configured to flow control none if hardware flow control is not used, see the Serial Port Adapter AT Commands document.

A.2.2.1 Logic level Mode

The serial UART interface can be used in a host controller application with a UART interface. The design of the interface depends on the power supply voltage of the host system; see Figure 12 for a 3.0/3.3V host system and Figure 13 for a 5V host system.

See section A.2.3.2 for information on how to select Logic level mode.

Note! It is very important to set the module in logic level mode properly when interfacing with logic levels; collision with the internal RS232 transceiver could damage the module.

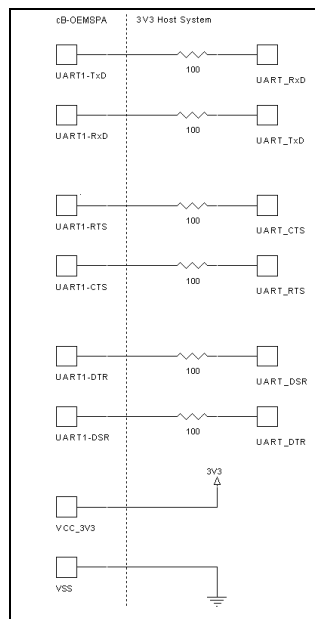

Figure 12: A complete UART interface with a 3.0/3.3V host system.

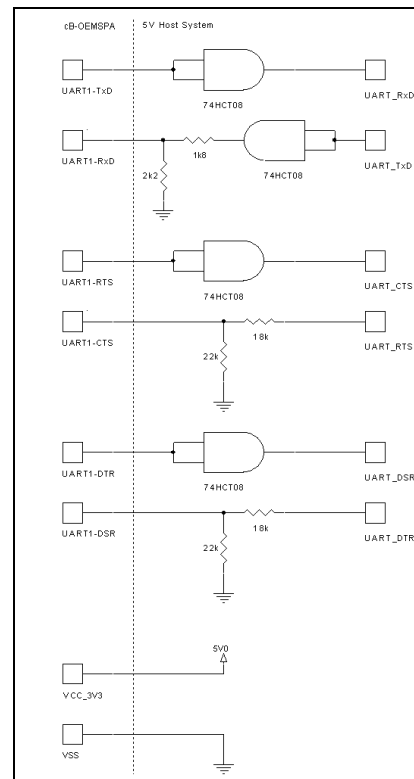

Figure 13: A complete UART interface with a 5V host system.

A.2.2.2 External RS232 driver

The modules are fully compatible with the EIA-232 standard and can be connected to all RS232 transceivers. Speed and current consumption depends on the host system RS232 transceiver. See Figure 14 for a complete example. Not used functionality can be left unconnected; see Section A.2.2.

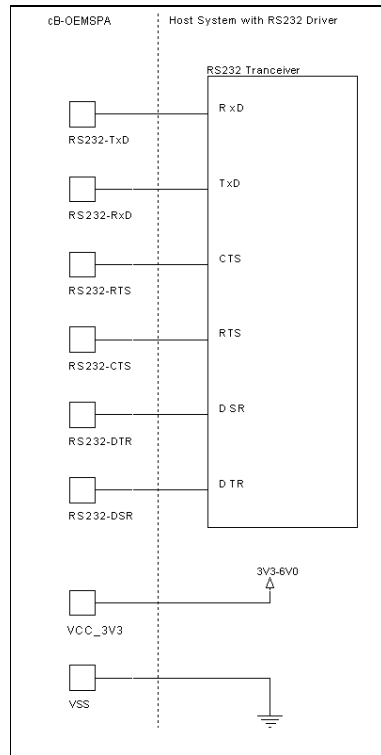

Figure 14: A complete RS232 interface.

A.2.2.3 External RS422 transceiver

An external RS422 driver could be used in a point-to-point (full duplex) application (see Figure 15).

The Logic level mode needs to be enabled when using an external transceiver. See section A.2.3.2 for information on how to select Logic level mode.

Note! It is very important to set the module in logic level mode properly when interfacing with logic levels; collision with the internal RS232 transceiver could damage the module.

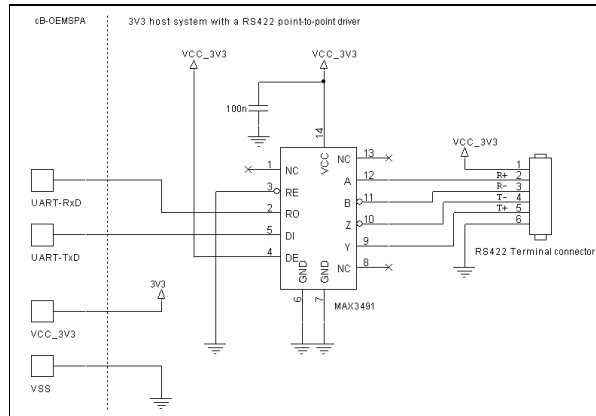

Figure 15: A complete RS422 interface.

A.2.2.4 External RS422/RS485 transceiver

A complete RS422/RS485 transceiver design connected to a bus system need to control the enable signals of the transceiver. The SerialSelect signals are used for this purpose (see Table 14).

The Logic level mode needs to be enabled when using an external transceiver. See section A.2.3.2 for information on how to select Logic level mode. The module need also to be software configured to the corrected interface, see the Serial Port Adapter AT Commands document how to configure the module to the correct serial interface.

Table 14: SerialSelect signals combinations

Serial Select-0	Serial Select-1	Internal RS232 Transceiver status	RS485/RS422 Transmitter status (Active high)	RS485/RS422 Receiver status (Active low)
0	0	Disabled	Disabled	Enabled
0	1	Disabled	Enabled	Enabled
1	0	Disabled	Enabled	Disabled
1	1	Enabled	Disabled	Disabled

Note! It is very important to set the module in logic level mode properly when interfacing with logic levels; collision with the internal RS232 transceiver could damage the module.

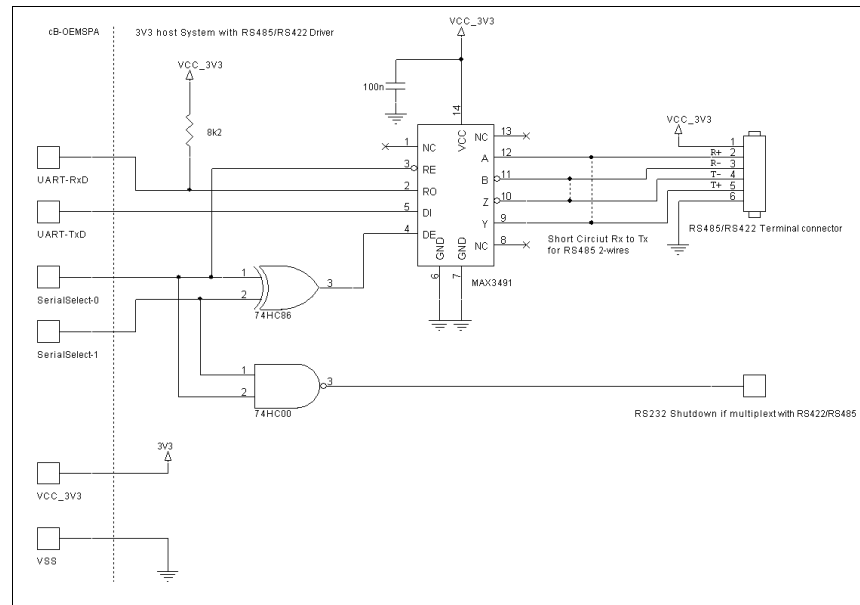

Figure 16: A complete RS422/RS488 transceiver design.

A.2.3 LED and Switch Design

A.2.3.1 BLUE Signal

The BLUE logic LED signal is not multiplexed with any other functionality, which makes the design more straightforward (for more information see Figure 17). There are two important notes:

- A blue LED requires about 3.5V forward voltage drop (cannot be used in a 3.3V system).
- The BLUE signal can be used to detect if the module is connected or not. The BLUE signal flashes when the module is sending and receiving data (see Chapter 3, Table 8). See Figure 18 for an example on how to suppress the flashes.

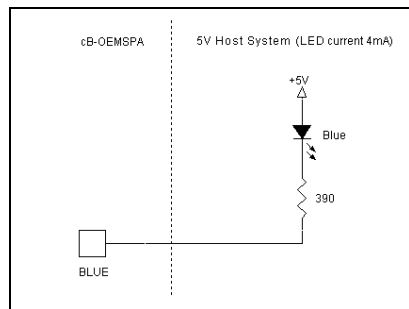

Figure 17: A blue LED can be connected directly to the module if the LED current is below 2mA. A high state (active low) makes the voltage drop over the LED to 2.2V. This is not enough to light the LED.

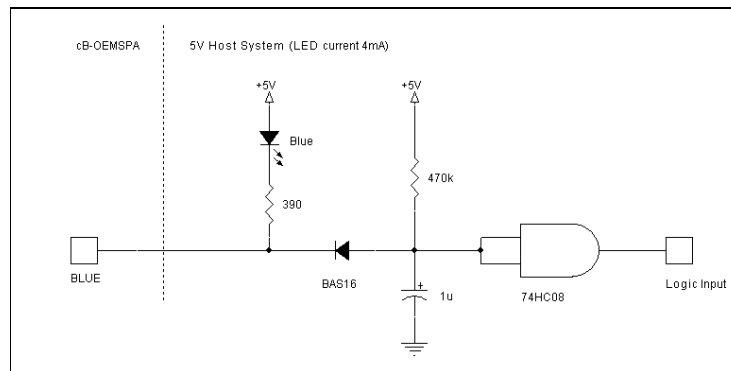

Figure 18: A Low pass filter and a 74HC08 suppress the flashes when the module is sending and receiving data. The Blue LED can be removed if not required. The values are not suited in all applications and need to be verified in a specific application.

A.2.3.2 RED/Mode Signal

The RED/Mode signal is a multiplexed signal:

- **RED** - Logic red LED signal (see Chapter 3, Table 8). Becomes valid 500ms after start up.
- **Mode** - The module reads the status of the signal during startup to decide if the serial interface shall be RS232 (HIGH) or logic UART (LOW) levels. The input signal must be stable for the first 500ms after startup (after reset/power on reset).

The signal is internally pulled-up (120kΩ) for RS232 as default.

If a LED is used in UART mode a high impedance buffer is required to prevent the signal from being pulled-up via the LED. A 74HC08 logic gate can be used in a 3.3V system (see Figure 19) and a 74HCT08 logic gate in a 5V system (see Figure 20). Both gates are available in a single gate package (74AHC1G08/74AHCT1G08).

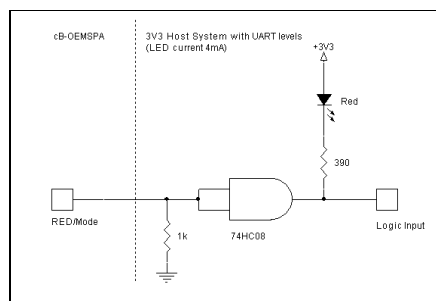

Figure 19: UART mode selected together with a red LED in a 3.3V host system. The status of the signal can also be used as input to a host controller.

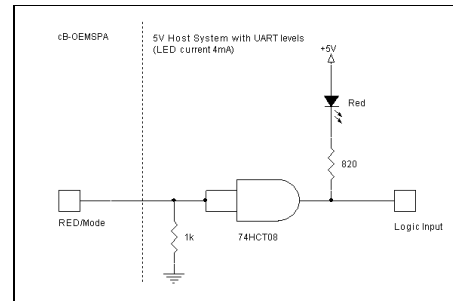

Figure 20: UART mode selected together with a red LED in a 5V host system. The status of the signal can also be used as input to a host controller.

The buffer can be removed in a 3.3V system if RS232 mode is used (see Figure 21).

In a 5V system the high state output (2.8V) from the module is not enough to turn off the LED so a 74HCT08 buffer can be used to raise the high level to 5V (see Figure 22).

The 74HCT08 gate is available in a single gate package (74AHCT1G08).

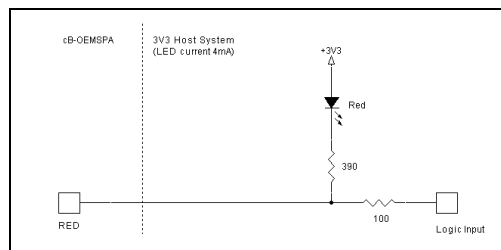

Figure 21: RS232 mode selected (default) together with a red LED in a 3.3V host system. The status of the signal can also be used as input to a host controller.

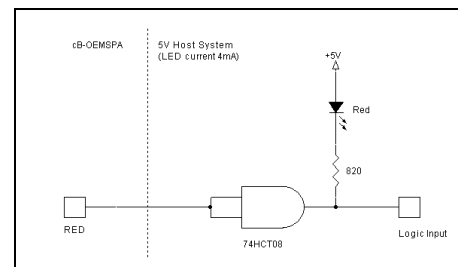

Figure 22: RS232 mode selected (default) together with a red LED in a 5V host system. The status of the signal can also be used as input to a host controller.

Only a pull-down on the RED/Mode pin is needed if UART mode is used but no red LED is required (see Figure 23). The RED/Mode pin can be left unconnected if RS232 (default) is used and no red LED required.

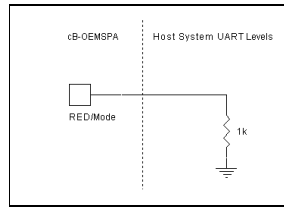

Figure 23: The mode pin is pulled-down (1k Ω) in UART mode.

A.2.3.3 GREEN/Switch-1 signal

The GREEN/Switch-1 signal is a multiplexed signal:

- **GREEN** - Logic green LED signal (see Chapter 3, Table 8). Becomes valid 500ms after start up.
- **Switch-1** - The module reads the status of the signal at startup to decide if the serial interface settings shall be restored (LOW) (see the Serial Port Adapter User Manual for more details). The input signal must be stable for the first 500ms after startup (after reset/power on reset).

The signal is internally pulled-up ($120k\Omega$) to 3.0V for NOT restoring settings to default.

If a LED is used and a switch is required to be able to restore the settings, a high impedance buffer need to prevent the signal from being pulled-up via the LED. A 74HC08 logic gate can be used in a 3/3.3V system (see Figure 24) and a 74HCT08 logic gate in a 5V system (see Figure 25).

Both gates are available in a single gate package (74AHC1G08/74AHCT1G08).

Sometimes, over time, switch contacts can get an oxide layer. This may cause the closed switch resistance to become too high to sink the signal to logic LOW (the signal is internally pulled-up to $120k\Omega$). A design that prevents this can be found in Figure 29.

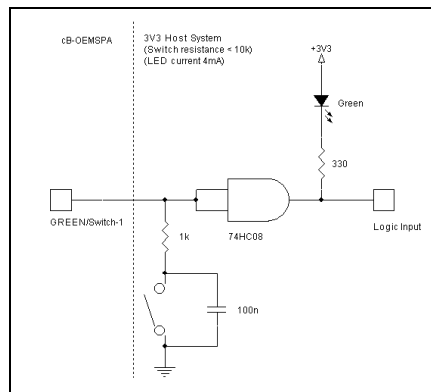

Figure 24: Switch-1 used together with a green LED in a 3.3V host system. The status of the signal can also be used as input to a host controller.

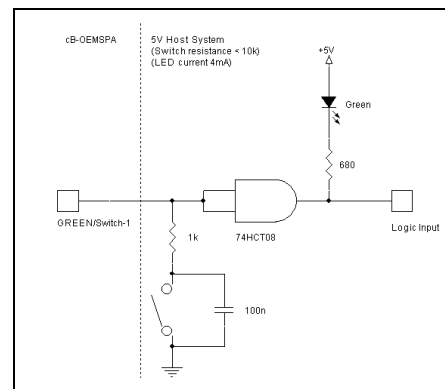

Figure 25: Switch-1 used together with a green LED in a 5V host system. The status of the signal can also be used as input to a host controller.

The buffer can be removed in a 3.3V system if no restore switch is required (see Figure 26).

In a 5V system the high state output (2.8V) from the module is not enough to turn off the LED, so a 74HCT08 buffer can be used to raise the high level to 5V (see Figure 27).

The 74HCT08 gate is also available in a single gate package (74AHCT1G08).

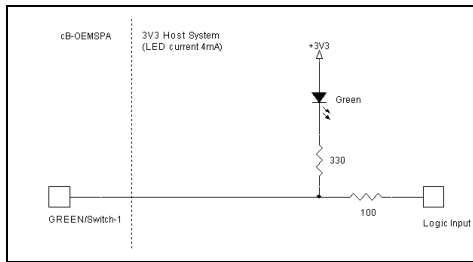

Figure 26: No restore switch used but a green LED in a 3.3V host system. The status of the signal can also be used as input to a host controller.

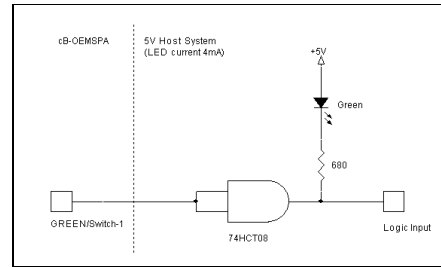

Figure 27: No restore switch used but a green LED in a 5V host system. The status of the signal can also be used as input to a host controller.

A serial resistor to the restore switch must be used to prevent a short circuit when the GREEN/Switch-1 pin is in output HIGH state and the switch is pressed (see Figure 28).

Sometimes, over time, switch contacts can get an oxide layer. This may cause the closed switch resistance to become too high to sink the signal to logic LOW (the signal is internally pulled-up to 120kΩ). A design that prevents this can be found in Figure 29.

The GREEN/Switch-1 pin can be left unconnected if none of its functionality is required.

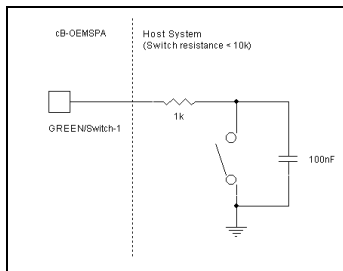

Figure 28: A low resistance restore switch used.

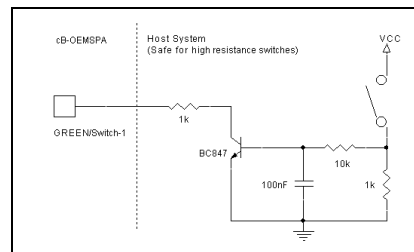

Figure 29: If the resistance in the switch is not guaranteed to be low enough, a safer design can be used.

A.2.3.4 Switch-0 Signal

Switch-0 is not multiplexed with other functionality and a switch is easily implemented (see Figure 30).

Sometimes, over time, switch contacts can get an oxide layer. This may cause the closed switch resistance to become too high to sink the signal to logic LOW (the signal is internally pulled-up to 120k Ω). A design that prevents this can be found in Figure 31.

The Switch-0 pin can be left unconnected if its functionality is not used.

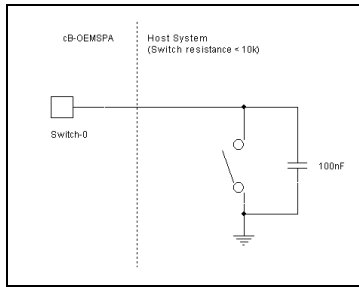

Figure 30: A low resistance function switch used.

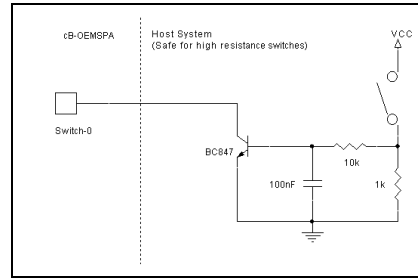

Figure 31: If the resistance in the switch is not guaranteed to be low enough, a safer design can be used.

A.2.4 Reset

The RESET pin can be connected to an external reset source, see Figure 32 for a switch example.

If the reset signal is connected to an output signal it must be an open drain collector, see Figure 33. Notice the capacitive load on the RESET pin in Table 6, section 2.3.

The RESET pin can be left unconnected if not used.

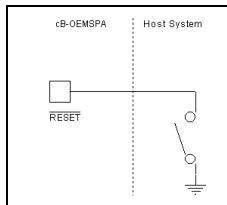

Figure 32: A reset switch.

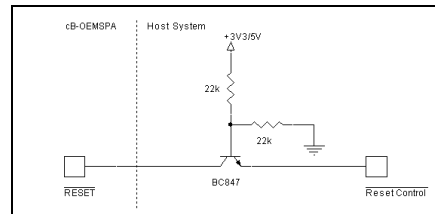

Figure 33: Design of an open collector reset from an active high output.

A.2.5 A Complete 5V Host System Interface

This is a complete 5V host system interface example with an RGB LED and two switches (except the serial interface, see section A.2.2 for information). The design is based on the LM339 Quad OP-amp instead of logic gates.

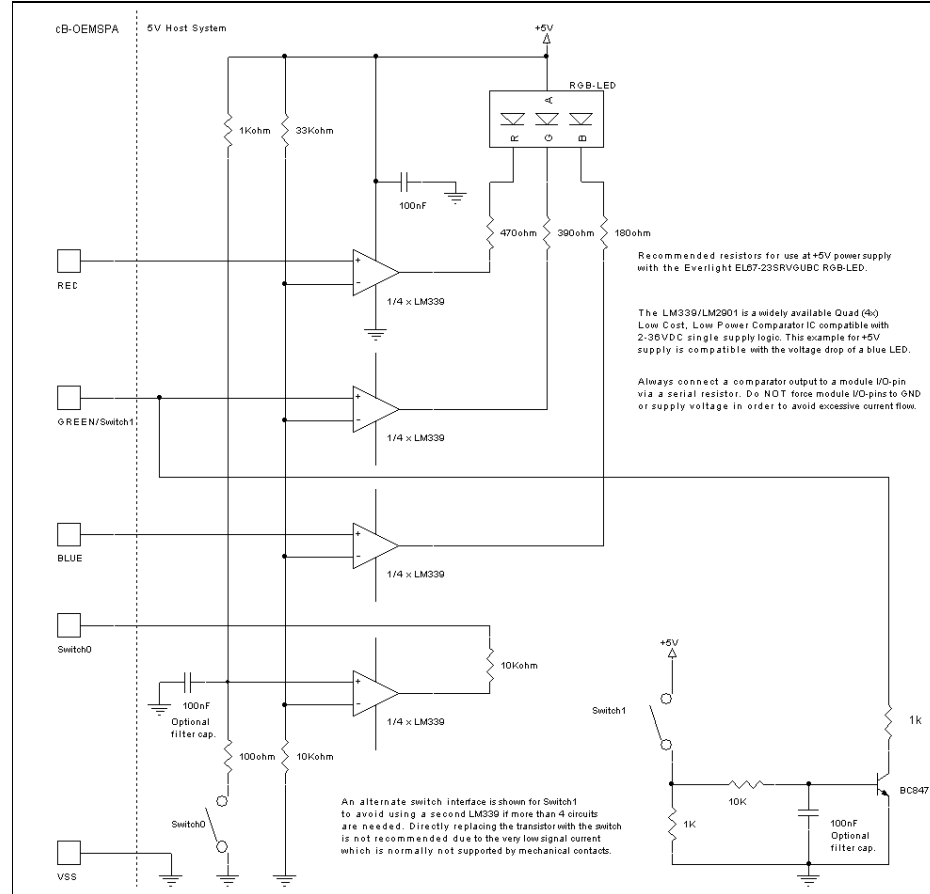

Figure 34: A complete 5V host interface with operational amplifier