

R41Z Module for Thread and Bluetooth 4.2 LE

The **R41Z Module** from Rigado is a highly-integrated, ultra-low power module that enables Bluetooth Low Energy and IEEE 802.15.4 connectivity based on the Kinetis KW41Z SoC from NXP Semiconductors. With an ARM® Cortex™ M0+ processor, embedded 2.4GHz transceiver supporting FSK/GFSK and O-QPSK modulations, and integrated antenna, the **R41Z** provides a complete RF solution with no additional RF design allowing faster time to market. Equipped with the ability to concurrently communicate over Bluetooth and Thread connections, the R41Z offers an unprecedented level of connectivity in a single module. With an internal DC-DC Converter and a wide supply voltage range of 0.9V to 4.2V, the **R41Z** can be directly powered by sources ranging from single alkaline cells to lithium polymer batteries.



1. Features

- Based on the NXP Kinetis KW41Z SoC
- Complete RF solution with integrated antenna
- Integrated DC-DC converter
- Arm® Cortex™-M0+ 32-bit processor
- Serial Wire Debug
- Over-the-Air (OTA) firmware updates
- 512kB embedded flash memory
- 128kb RAM
- 25 GPIO, 2 dedicated analog pins
- 16-bit/500KSPS ADC
- 12-bit DAC
- -40°C to +105°C Temperature Range
- Rigado Software Suite
- 16 Capacitive Touch Sensing Inputs
- Two SPI Master/Slave (12Mbps)
- Two I²C Master/Slave
- UART (w/ CTS/RTS and DMA)
- Low power comparator
- Temperature sensor
- Infrared communication interface
- Nine low power modes
- True Random Number Generator
- 128-bit AES HW encryption
- 32bit Real-Time Clock (RTC)
- Wi-Fi coexistence support
- Dimensions: 10.6 x 16.2 x 2.1mm
- FCC: 2AA9B07
- IC: 12208A-07
- Japan: **TBD**

2. Applications

- Home/Office/Hotel Automation
- Low-Power Sensor Networks
- Home Appliances
- Lighting Products
- Climate Control
- Environmental Monitoring
- Home Health Care
- Safety and Security
- Access Control
- Smart Energy Management

3. Ordering Information

Email module@rigado.com for quotes and ordering, or visit www.rigado.com/R41Z

Part Number	Description
R41Z-TA-R	R41Z module, Rev A, Tape & Reel, 1000 piece multiples
R41Z-TA-EVAL	R41Z Evaluation Kit with OpenSDA programmer

Table 1 - Ordering Part Numbers

4. Block Diagram

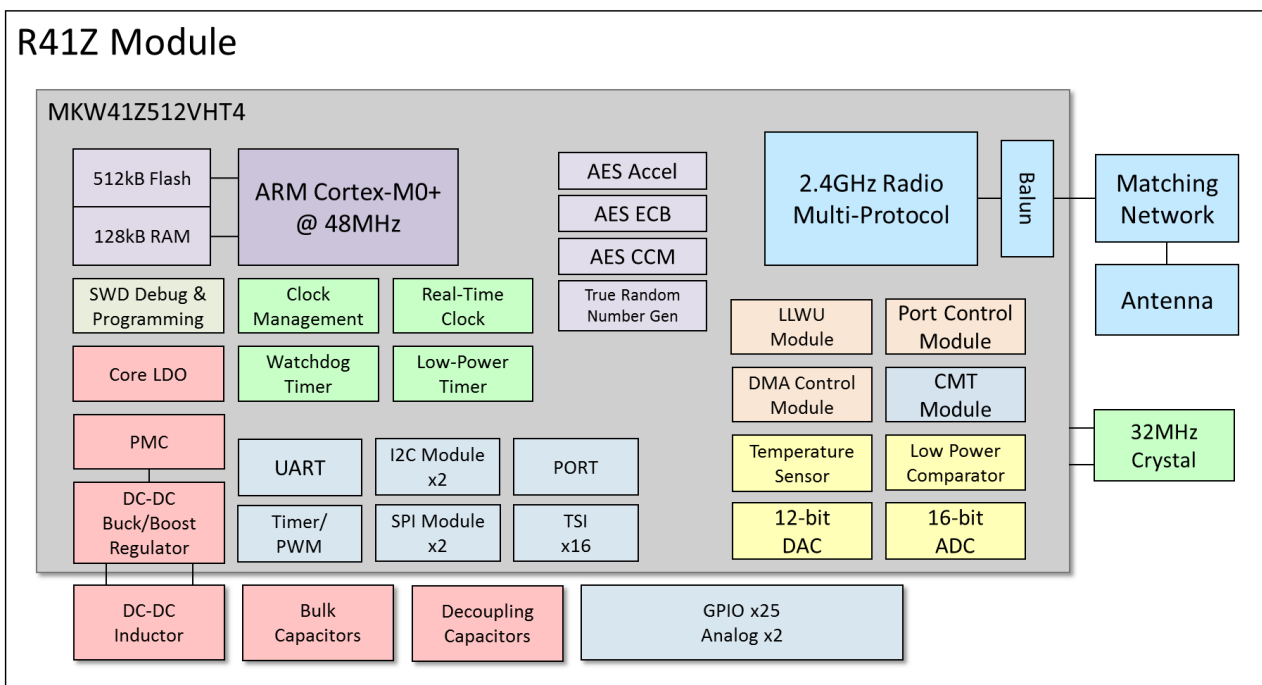

Figure 1 - Block Diagram

Table of Contents

1.	FEATURES	1
2.	APPLICATIONS	1
3.	ORDERING INFORMATION	2
4.	BLOCK DIAGRAM	2
5.	QUICK SPECIFICATIONS	6
6.	PIN DESCRIPTIONS	7
6.1	R41Z PIN FUNCTIONS	7
6.2	RIGDFU PIN FUNCTIONS	8
7.	ELECTRICAL SPECIFICATIONS	9
7.1	ABSOLUTE MAXIMUM RATINGS	9
7.2	OPERATING CONDITIONS	9
7.3	DCDC CONVERTER OPERATION	9
7.3.1	DCDC BYPASS MODE	10
7.3.2	DCDC BUCK MODE	11
7.3.3	DCDC BOOST MODE	12
7.4	GENERAL PURPOSE I/O AND PORTS	14
7.5	ANALOG I/O AND VREF	15
7.5.1	ANALOG SIGNALS AND MAPPING	15
7.5.2	VDDA AND VREF	15
7.6	MODULE RESET	16
7.7	DEBUG AND PROGRAMMING	16
7.8	CLOCKS	16
8.	FIRMWARE	17
8.1	FACTORY IMAGE	17
8.1.1	FIRMWARE VERSION '00'	17
8.2	MAC ADDRESS INFO	17
9.	MECHANICAL DATA	18
9.1	PACKAGE DIMENSIONS	18
9.2	RECOMMENDED PCB FOOTPRINT	19
10.	MODULE MARKING	19
11.	RF DESIGN NOTES	20
11.1	RECOMMENDED RF LAYOUT AND GROUND PLANE	20
11.2	MECHANICAL ENCLOSURE	20
11.3	ANTENNA PATTERNS	21
11.3.1	X-Y PLANE	21
11.3.2	Y-Z PLANE	21
11.3.3	Z-X PLANE	21
12.	EVALUATION BOARDS	21
13.	CUSTOM DEVELOPMENT	22
14.	BLUETOOTH QUALIFICATION	22
15.	REGULATORY STATEMENTS	22
15.1	FCC STATEMENT	22
15.2	FCC IMPORTANT NOTES:	23
15.3	IC STATEMENT:	24
15.4	IC IMPORTANT NOTES:	25
15.5	CE REGULATORY:	25
15.6	JAPAN (MIC)	26
15.7	AUSTRALIA / NEW ZEALAND	26
16.	SOLDER REFLOW TEMPERATURE-TIME PROFILE	27
16.1	MOISTURE SENSITIVITY LEVEL	27



R41Z Module Data Sheet

Thread + Bluetooth 4.2 LE

November 17, 2016

17.	PACKAGING AND LABELING	28
17.1	CARRIER TAPE DIMENSION	28
17.2	REEL PACKAGING	28
17.3	PACKAGING LABEL	29
18.	CAUTIONS.....	29
19.	LIFE SUPPORT POLICY	30
20.	DOCUMENT HISTORY.....	30
21.	RELATED DOCUMENTS.....	30

Table of Figures

FIGURE 1 - BLOCK DIAGRAM	2
FIGURE 2 - R41Z PIN OUT (TOP VIEW)	7
FIGURE 3 - SCHEMATIC: DCDC BYPASS MODE EXAMPLE	10
FIGURE 4 - SCHEMATIC: DCDC BUCK MODE EXAMPLE.....	11
FIGURE 5 - SCHEMATIC: DCDC BUCK MODE PSWITCH EXAMPLE	12
FIGURE 6 - SCHEMATIC: DCDC BOOST MODE EXAMPLE	13
FIGURE 7 - PCB: BOOST MODE SUGGESTED LAYOUT	14
FIGURE 8 - SCHEMATIC: LOW FREQUENCY CRYSTAL	17
FIGURE 9 - R41Z MAC ADDRESS ON LABEL.....	18
FIGURE 10 - R41Z MODULE DIMENSIONS.....	18
FIGURE 11 - R41Z PAD LAYOUT (TOP VIEW)	19
FIGURE 12 - R41Z MODULE MARKING - ENG REV2.....	19
FIGURE 13 - R41Z RF EXAMPLE BASED ON EVAL BOARD.....	20
FIGURE 14 - R41Z EVALUATION BOARD.....	21
FIGURE 15 - REFLOW PROFILE FOR LEAD FREE SOLDER	27
FIGURE 16 - REEL CARTONS	28
FIGURE 17 - PACKAGING LABEL	29

Specification Tables

TABLE 1 - ORDERING PART NUMBERS.....	2
TABLE 2 - QUICK SPECIFICATIONS	6
TABLE 3 - R41Z PIN DESCRIPTIONS	8
TABLE 4 - RIGDFU FUNCTIONS.....	8
TABLE 5 - ABSOLUTE MAXIMUM RATINGS	9
TABLE 6 - OPERATING CONDITIONS	9
TABLE 7 - DCDC MODE CONNECTIONS.....	10
TABLE 8 - DCDC BUCK MODE CONNECTIONS	11
TABLE 9 - DCDC BOOST MODE CONNECTIONS	12
TABLE 10 - GPIO PROPERTIES	15
TABLE 11 - ANALOG SIGNALS	15
TABLE 12 - ANALOG PROPERTIES	16
TABLE 13 - LOW FREQUENCY CRYSTAL RECOMMENDED SPECIFICATIONS	16

5. Quick Specifications

Bluetooth		
Version	4.2	
Security	AES-128	
LE Connections	2	
Thread (IEEE 802.15.4)		
Security	AES-128	
Node Types	Router Eligible, End Device, REED	
Radio		
Frequency	2.360GHz to 2.483GHz	
Modulations	GFSK @ 1Mbps, OQPSK @ 250kbps	
Transmit power	+3.5dbm	
Receiver sensitivity	-95dBm (BLE), -100dBm (IEEE 802.15.4)	
Antenna	Integrated	
Current Consumptions		
TX only @ 0dBm, bypass mode	14.7 mA	
TX only @ 0dBm, DCDC enabled, 3.6V Vin	6.1mA	
RX only, bypass mode	16.2mA	
RX only, DCDC enabled, 3.6V Vin	6.7mA	
Normal Run CPU @ 48MHz @ 3.0V, DCDC enabled	4.8mA	
Very-Low-Power Run CPU @ 4MHz @ 3.0V, DCDC enabled	137µA	
Very-Low-Leakage Stop 3 (RAM retained) @ 3.0V @ 25°C, DCDC enabled	1.8 µA	
Very-Low-Leakage Stop 0 @ 3.0V @25°C, bypass mode	182 nA	
Dimensions		
Length	16.2 mm ± 0.3mm	
Width	10.6 mm ± 0.3mm	
Height	2.1 mm ± 0.1mm	
Hardware		
Interfaces	SPI Master/Slave x2 UART x1 Touch Sense Interface x16	Two-Wire Mast/Slave (I2C) x2 GPIO x25 Analog input x6
Power Supply	Boost mode: 0.9V to 1.8V, 1.1V required at startup Bypass mode: 1.71V to 3.6V Buck mode: 1.8V to 4.2V, 2.1V required at startup	
Temperature Range	-40 to +105 °C	
Certifications		
FCC	FCC part 15 modular certification ID: 2AA9B07	
IC	Industry Canada RSS-210 modular certification IC: 12208A-07	
CE	EN 60950-1: 2011-01 EN 301 489-1 V1.9.2 & EN 301 489-17 V2.2.1 EN 300 328 V1.9.1	3.1 (a): Health and Safety of the User 3.1 (b): Electromagnetic Compatibility 3.2: Effective use of spectrum allocated
Japan (MIC)	Ministry of Internal Affairs and Communications (MIC) of Japan pursuant to the Radio Act of Japan	
Australia / New Zealand	AS/NZS 4268 :2012+AMDT 1:2013, Radio equipment and systems – Short range devices	
Bluetooth	Pending	
Thread	Pending	

Table 2 - Quick Specifications

6. Pin Descriptions

6.1 R41Z Pin Functions

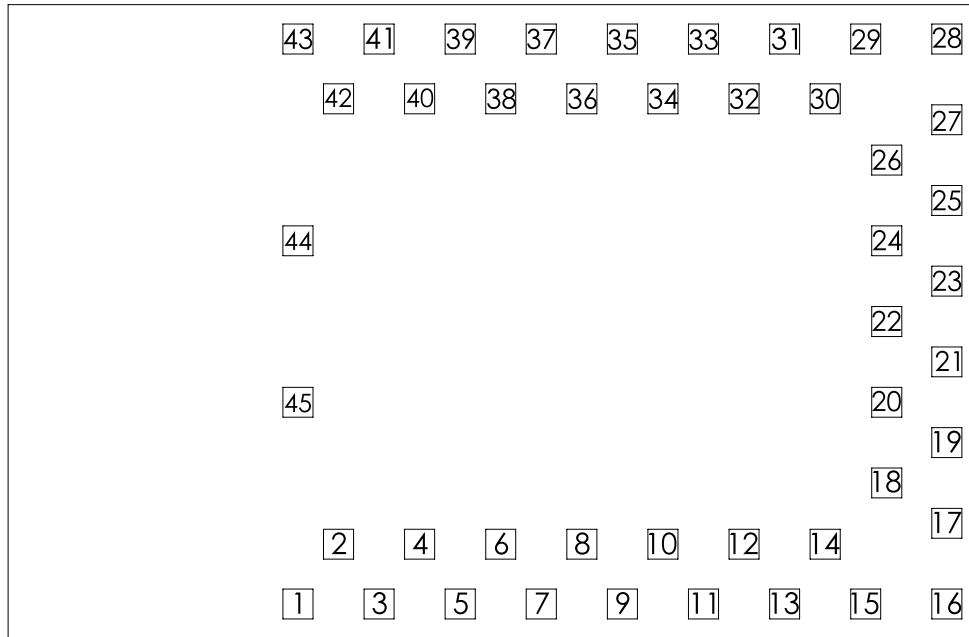

Figure 2 - R41Z Pin out (Top View)

GPIO/Analog				
Pin	Name	Direction	Description	Default State at POR
2	PTC1	In/Out	GPIO	Disabled
3	PTC2	In/Out	GPIO	Disabled
4	PTC3	In/Out	GPIO	Disabled
5	PTC4	In/Out	GPIO	Disabled
6	PTC5	In/Out	GPIO	Disabled
7	PTC6	In/Out	GPIO	Disabled
8	PTC7	In/Out	GPIO	Disabled
10	PTC16	In/Out	GPIO	Disabled
11	PTC17	In/Out	GPIO	Disabled
12	PTC18	In/Out	GPIO	Disabled
13	PTC19	In/Out	GPIO	Disabled
14	PTA0	In/Out	GPIO	SWDIO, Pullup EN
15	PTA1	In/Out	GPIO	SWCLK, Pulldown EN
17	PTA2	In/Out	GPIO	Reset, Pullup EN
18	PTA16	In/Out	GPIO	Disabled
19	PTA17	In/Out	GPIO	Disabled
20	PTA18	In/Out	GPIO	Disabled
21	PTA19	In/Out	GPIO	Disabled

Pin	Name	Direction	Description	Default State at POR
30	PTB0	In/Out	GPIO	Disabled
31	PTB1	In/Out	GPIO	Disabled
32	PTB2	In/Out	GPIO	Disabled
33	PTB3	In/Out	GPIO	Disabled
34	PTB16	In/Out	GPIO	EXTAL32K
36	PTB17	In/Out	GPIO	XTAL23K
37	PTB18	In/Out	GPIO	Non Maskable Interrupt Req.
38	ADC0_P	In	ADC/Comparator input	N/A
39	ADC0_N	In	ADC/Comparator input	N/A
Reference Signals				
Pin	Name	Direction	Description	
40	XTAL_OUT	Out	32MHz Clock output	
41	VREF	In/Out	Analog reference voltage. Internally or externally sourced	
42	VDDA	Power	Analog supply. Internally sourced ¹	
Power				
Pin	Name	Direction	Description	
22	PSWITCH	Input	DCDC start signal ²	
23	DCDC_CFG	Input	DCDC mode ²	
25	VCC	Power	DCDC input ²	
26	DCDC_LP	Power	DCDC signal ²	
27	V1P8	Power	DCDC IO and peripheral voltage ²	
29	V1P5	Power	DCDC RF supply ²	
1, 9, 16, 24, 28, 35, 43, 44, 45	GND	Power	Electrical Ground	
Note 1: VDDA is tied to V1P8 through a power filtering circuit on the R41Z module				
Note 2: See the DCDC Converter Operation section for details on signal usage and DCDC modes				

Table 3 - R41Z Pin Descriptions

6.2 RigDFU Pin Functions

When loaded with RigDFU, two GPIO pins are configured as UART pins for transferring new firmware images to the R41Z. Pins are configured only when the bootloader is running and are fully available to the application firmware. RigDFU can be removed from the R41Z by performing a full-chip erase.

Pin	Name	Direction	RigDFU Functions
7	PTC6	In	UART-RX for bootloader. Internal pulldown enabled.
8	PTC7	Out	UART-TX for bootloader. Hi-Z until bootloader activation message received on UART RX

Table 4 - RigDFU Functions

7. Electrical Specifications

7.1 Absolute Maximum Ratings

Symbol	Parameter	Condition	Min.	Max.	Unit
V _{cc_MAX}	Voltage on Supply Pin	DCDC Boost Mode	-0.3	1.8	V
		DCDC Bypass Mode	-0.3	3.6	V
		DCDC Buck Mode	-0.3	4.2	V
V _{1P8_MAX}	Voltage on V1P8 and GPIO	All DCDC modes	-0.3	3.6	V
V _{RF_MAX}	Voltage on V1P5	All DCDC modes	-0.3	3.6	V
T _S	Storage Temperature	-	-40	125	°C

Table 5 - Absolute Maximum Ratings

7.2 Operating Conditions

Symbol	Parameter	Condition	Min.	Typ.	Max.	Unit
V _{cc}	Voltage on Supply Pin	DCDC Boost Mode	0.9 ¹	1.5	1.8	V
		DCDC Bypass Mode	1.71	3.3	3.6	V
		DCDC Buck Mode	1.8 ²	3.3	4.2	V
V _{1P8}	Voltage on V1P8 and GPIO	All DCDC modes	1.45	3.3	3.6	V
V _{RF}	Voltage on V1P5	All DCDC modes	1.8	3.3	3.6	V
I _{1P8}	V1P8 output current	DCDC Buck Mode, 1.8Vout	-	-	45	mA
		DCDC Buck Mode, 3.0Vout	-	-	27	mA
		DCDC Boost Mode, 1.7Vin, 1.8 Vout	-	-	45	mA
		DCDC Boost Mode, 0.9Vin, 3.0Vout	-	-	10	mA
T _A	Ambient Temperature	-	-40	25	85	°C
Note 1: In Boost mode a minimum of 1.1V is required to start the DCDC converter. Once started, the converter can operate at 0.9V						
Note 2: In Buck mode a minimum of 2.1V is required to start the DCDC converter.						

Table 6 - Operating Conditions

7.3 DCDC Converter Operation

The R41Z module contains an integrated DCDC converter which allows for three modes of operation without additional components. When operating in DCDC Buck mode, power consumption from using the radio can be reduced compared to DCDC Bypass mode. DCDC Boost mode allows the use of a single alkaline or other low voltage source. While it is possible to switch between these modes in a single design, for example the R41Z Evaluation Board, it is not recommended to switch between modes while power is applied.

7.3.1 DCDC Bypass Mode

Mode	Pin	Name	Net Connection
Bypass	22	PSWITCH	Ground
	23	DCDC_CFG	1.71V - 3.6V Source IN
	25	VCC	1.71V - 3.6V Source IN
	26	DCDC_LP	No Connection
	27	V1P8	1.71V - 3.6V Source IN
	29	V1P5	1.45V - 3.6V Source IN

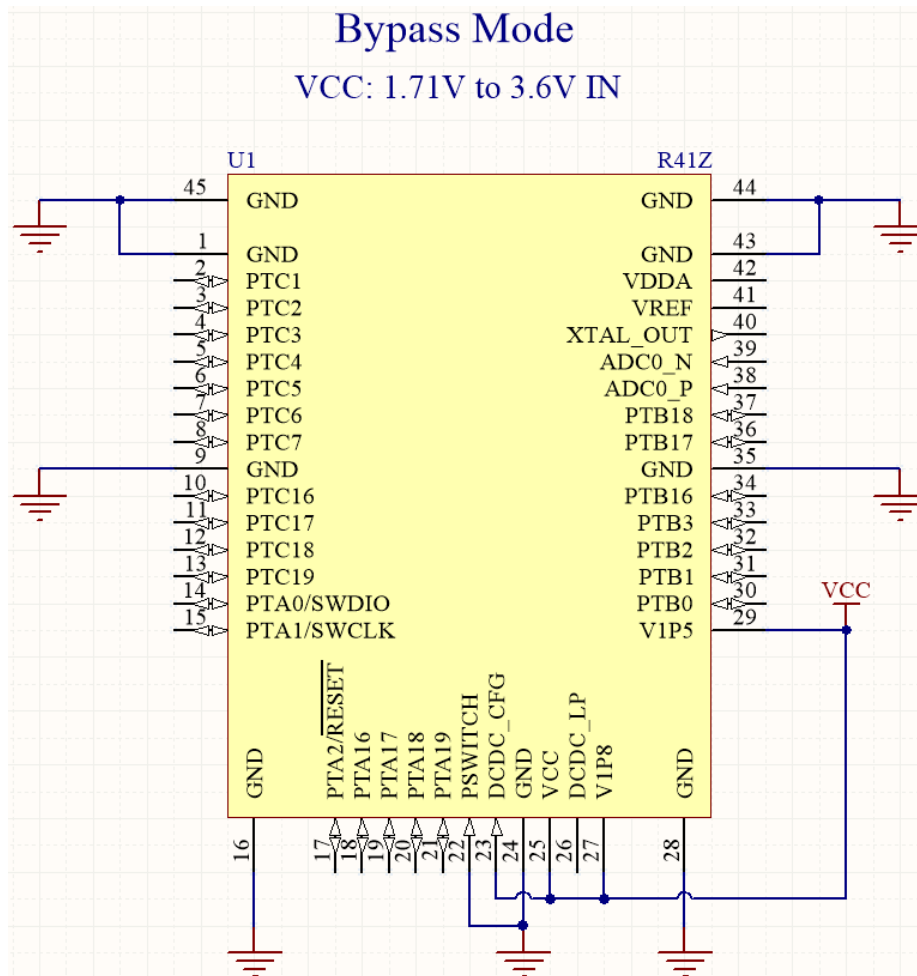
Table 7 - DCDC Mode Connections

Figure 3 - Schematic: DCDC Bypass Mode Example

7.3.2 DCDC Buck Mode

Mode	Pin	Name	Net Connection
Buck	22	PSWITCH ¹	1.8V - 4.2V Source IN
	23	DCDC_CFG	1.8V - 4.2V Source IN
	25	VCC	1.8V - 4.2V Source IN
	26	DCDC_LP	No Connection
	27	V1P8	No Connection or 1.8V – 3.0V OUT ²
	29	V1P5	No Connection

Note 1: In Buck mode PSWITCH can inhibit the DCDC converter from starting when the source voltage is applied. When PSWITCH is connected to the source voltage, the DCDC converter will start. Once started, PSWITCH can be reconnected to GND without disrupting the DCDC converter's operation.

Note 2: V1P8 is the R41Z's IO voltage when the DCDC converter is running in either Buck or Boost mode. V1P8 can source a limited number or additional peripheral devices (sensors, LEDs, etc.) that connect directly to the R41Z's IO. In Buck mode, V1P8 cannot output a voltage greater than the source voltage

Table 8 - DCDC Buck Mode Connections

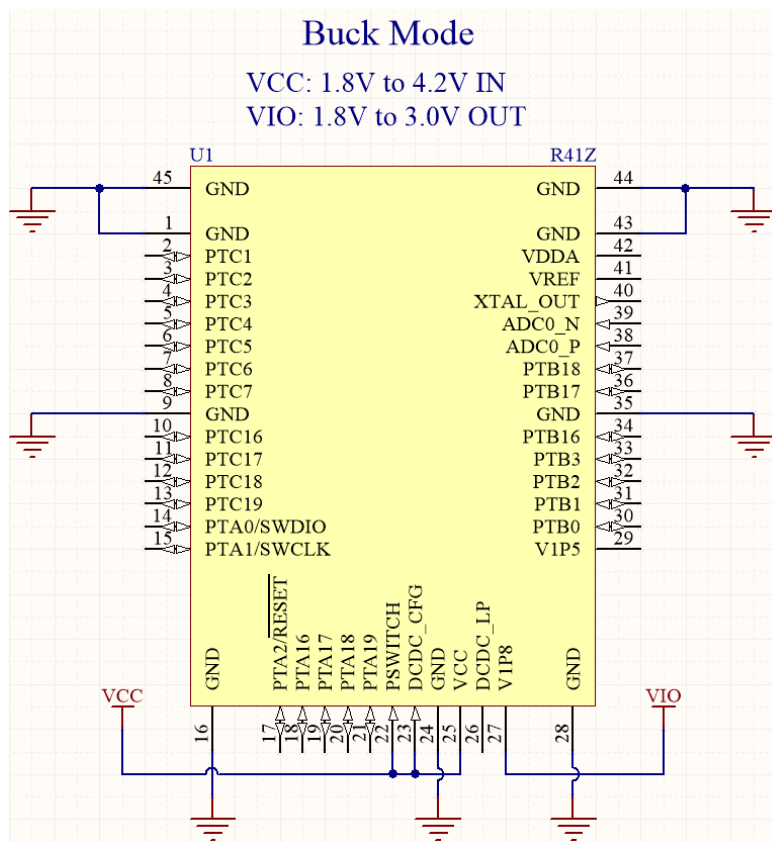

Figure 4 - Schematic: DCDC Buck Mode Example

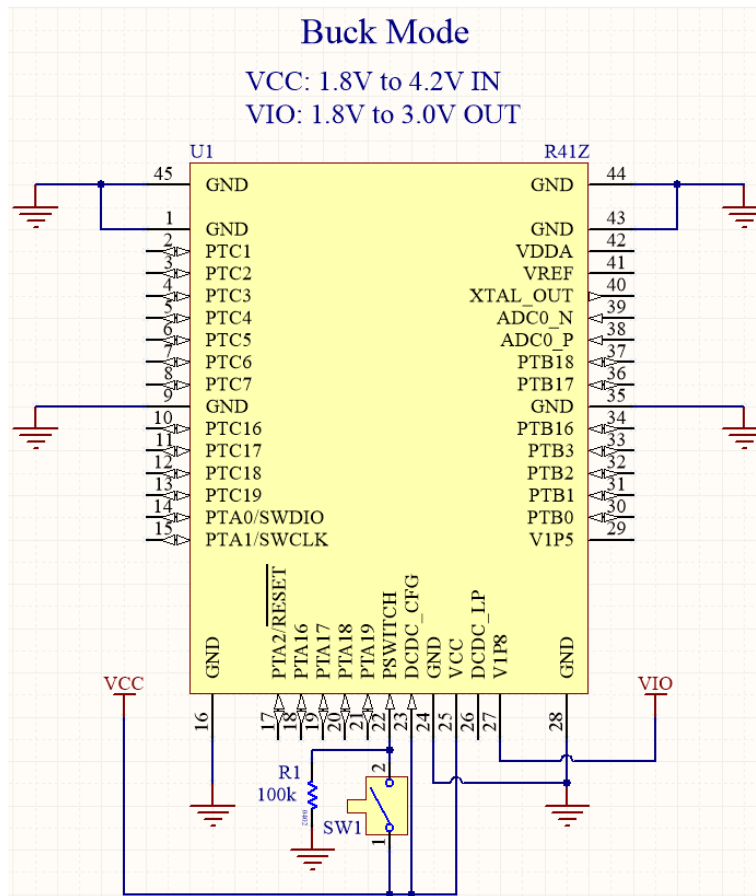

Figure 5 - Schematic: DCDC Buck Mode PSWITCH Example

7.3.3 DCDC Boost Mode

Mode	Pin	Name	Net Connection
Boost	22	PSWITCH	0.9V – 1.8V Source IN
	23	DCDC_CFG	Ground
	25	VCC	0.9V – 1.8V Source IN
	26	DCDC_LP	0.9V – 1.8V Source IN
	27	V1P8	No Connection or 1.8V – 3.0V OUT ¹
	29	V1P5	No Connection

Note 1: V1P8 is the R41Z's IO voltage when the DCDC converter is running in either Buck or Boost mode. V1P8 can source a limited number or additional peripheral devices (sensors, LEDs, etc.) that connect directly to the R41Z's IO.

Table 9 - DCDC Boost Mode Connections

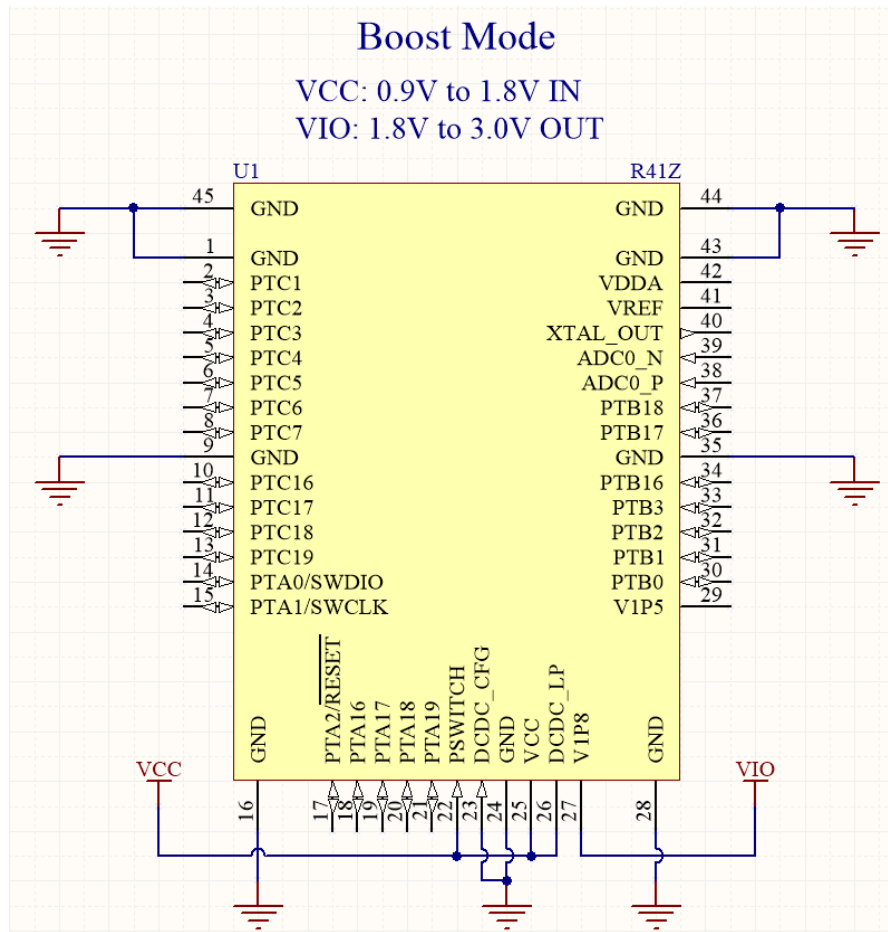

Figure 6 - Schematic: DCDC Boost Mode Example

When using Boost Mode care should be taken to ensure that DCDC_LP (Pin 26) is connected to VCC (Pin 25) with a trace wide enough to carry the full current expected to be drawn from the R41Z module and any peripherals sourced by the module. The connection should also be as short as possible.

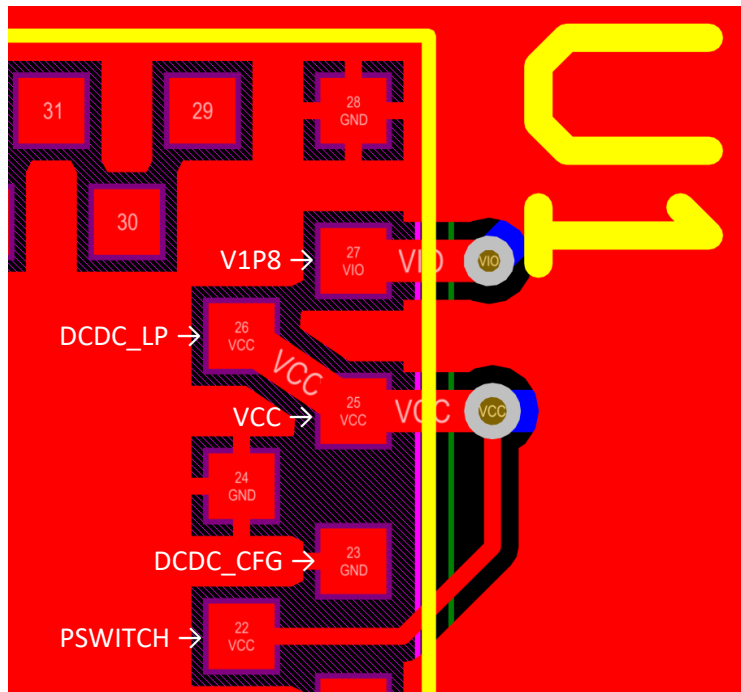

Figure 7 - PCB: Boost Mode Suggested Layout

7.4 General Purpose I/O and ports

The general purpose I/O is organized as three ports (A, B, and C) that enable access and control to each of the 25 available GPIO pins. Each GPIO can be configured individually through a Pin Control Register (PCR) and Port Data Direction Register (PDDR) with the following available features:

- Input/Output direction
- Output drive strength
- Internal pull-up and pull-down resistors
- Trigger interrupts and/or DMA from input
- Read and clear interrupt flags
- Enable passive input filter
- Fast/slow slew rate selection
- Control pin muxing to internal modules

To use a pin as GPIO set the Pin Mux Control field of the pin to ALT1 in the PCR. Ports must have their clock source enabled in the System Clock Gating Control Register 5 (SIM_SCGC5) before accessing any port registers. Attempting to access port registers without the port clock enabled will cause program execution to immediately vector to the default exception handler. Disabling the clock to ports that are not being used will reduce power consumption. Ports should be disabled before turning off the clock.

Symbol	Parameter	Min	Max.	Unit
V_{IH}	Input High Voltage, $2.7V \leq V_{IO} \leq 3.6V$	$0.7 \times V_{IO}$	-	V
	Input High Voltage, $1.7V \leq V_{IO} \leq 2.7V$	$0.75 \times V_{IO}$	-	V
V_{IL}	Input Low Voltage, $2.7V \leq V_{IO} \leq 3.6V$	-	$0.35 \times V_{IO}$	V
	Input Low Voltage, $1.7V \leq V_{IO} \leq 2.7V$	-	$0.3 \times V_{IO}$	V

Symbol	Parameter	Min	Max.	Unit
V _{HYS}	Input Hysteresis	-	0.06 × V _{IO}	V
V _{OH}	Output High Voltage	V _{IO} – 0.5	-	V
V _{OL}	Output Low Voltage	-	0.5	V
R _P	Pull resistance	20	50	kΩ

Table 10 - GPIO Properties

7.5 Analog I/O and VREF

7.5.1 Analog Signals and Mapping

Analog ADC, DAC, and comparator signals can be routed to a select set of port or dedicated analog pins. Generally, on port pins the analog function can be used by setting the Pin Mux Control field in the PCR of the pin to ALTO.

Signal	Direction	Description	Pin	Port	Mux Alt
CMPO_OUT	Out	Comparator 0 Output	30	PTB0	ALT4
CMPO_IN0	In	Comparator 0 Single-ended input 0	38	-	-
CMPO_IN1	In	Comparator 0 Single-ended input 1	39	-	-
CMPO_IN2	In	Comparator 0 Single-ended input 2	37	PTB18	ALTO
CMPO_IN3	In	Comparator 0 Single-ended input 3	32	PTB2	ALTO
CMPO_IN4	In	Comparator 0 Single-ended input 4	33	PTB3	ALTO
CMPO_IN5	In	Comparator 0 Single-ended input 5	31	PTB1	ALTO
ADC0_SE0	In	ADC Channel 0 Single-ended input 0	31	PTB1	ALTO
ADC0_SE1	In	ADC Channel 0 Single-ended input 1	33	PTB3	ALTO
ADC0_SE2	In	ADC Channel 0 Single-ended input 2	32	PTB2	ALTO
ADC0_SE3	In	ADC Channel 0 Single-ended input 3	37	PTB18	ALTO
ADC0_SE4	In	ADC Channel 0 Single-ended input 4	21	PTA19	ALTO
ADC0_DP0	In	ADC Channel 0 Differential input positive	38	-	-
ADC0_DN0	In	ADC Channel 0 Differential input negative	39	-	-
DAC0_OUT	In	DAC Channel 0 Single-ended output	37	PTB18	ALTO

Table 11 - Analog Signals

7.5.2 VDDA and VREF

The source voltage for the analog sub-system, VDDA, is supplied by V1P8 through a filtering circuit onboard the R41Z module. The voltage reference pin, VREF, has two sourcing options: internal and external. When externally supplied, VREF should be referenced to VDDA. Internal sourcing is provided by a resistor trimmed circuit. For details on using the analog modules, see the MKW41Z512 data sheet.

Symbol	Parameter	Min	Typ.	Max.	Unit
V _{DDA}	Analog supply voltage	1.71	V _{1P8}	V _{1P8}	V
V _{REF_OUT}	VREF internally sourced, factory trim	1.190	1.1950	1.200	V
V _{REFH}	VREF externally sourced	1.13	V _{DDA}	V _{DDA}	V
V _{ADIN}	16-bit, differential mode	GND	-	31/32 × V _{REFH}	V
	16-bit, All other modes	GND	-	V _{REFH}	V
V _{ACIN}	CMP/6-bit ADC analog input voltage	GND – 0.3	-	V _{1P8}	V
V _{ACIO}	CMP/6-bit ADC analog input voltage offset	-	-	20	mV
I _{CMP}	CMP current, High-speed mode	-	-	200	μA

Symbol	Parameter	Min	Typ.	Max.	Unit
	CMP current, Low-speed mode	-	-	20	μ A
V _{CMPH}	Comparator output high	V _{1P8} - 0.5	-	-	V
V _{CMPL}	Comparator output low	-	-	0.5	V

Table 12 - Analog Properties

7.6 Module Reset

Pin 17, PTA2, is used as an external reset source by default. This pin can be used for other functions, such as GPIO, by setting the RESET_PIN_CFG option bit of the FTFA_FPORT register to 0. The setting of this bit is retained through system resets and low power modes.

7.7 Debug and Programming

The R41Z module supports the two pin Serial Wire Debug (SWD) interface and offers flexible and powerful mechanisms for non-intrusive debugging of program code. Breakpoints, single stepping, and instruction trace capture of code execution flow are part of this support. The R41Z also supports Micro Trace Buffer (MTB) which provides a lightweight program trace capabilities using system RAM. SWD pins can be repurposed as additional GPIO by the application.

7.8 Clocks

The R41Z requires two clocks: a high frequency clock and a low frequency clock.

The high frequency clock is provided on-module by a high accuracy 32-MHz crystal which is required for Real Time Clock (RTC) and radio DeepSleep Mode (DSM) operation. In most applications, an external crystal oscillator is required to provide the low frequency clock.

For normal run modes, an internal oscillator can provide the low frequency clock. However, to maintain radio functionality in reduced power modes an external crystal must be used.

For most applications using the low frequency clock, external capacitors are not required. Internal, programmable capacitors are provided on the R41Z module. In applications that use Rigado provided firmware, use the typical specifications listed below.

An external clock source can be used in place of a crystal. In this case, the clock source should be connected to the EXTAL32K pin (PTB16). XTAL23K (PTB17) should be left unconnected.

Low Frequency Crystal

Symbol	Parameter	Typ.	Max.	Unit
F _{NOM_LFXO}	Crystal frequency	32.768	-	kHz
F _{TOL_LFXO_BLE}	Frequency tolerance, BLE applications	\pm 20	\pm 250	ppm
C _{L_LFXO}	Load Capacitance	7	12.5	pF

Table 13 – Low Frequency Crystal Recommended Specifications

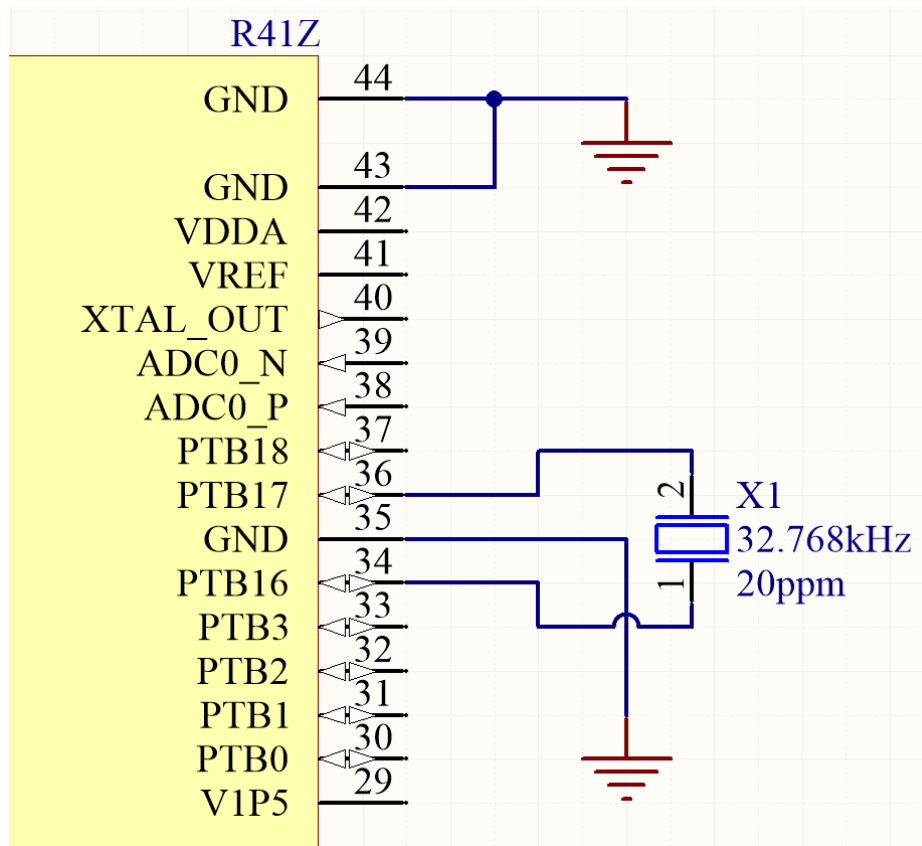

Figure 8 - Schematic: Low Frequency Crystal

8. Firmware

8.1 Factory Image

All modules are shipped with factory programmed firmware. The factory programmed firmware version is indicated on the label.



Factory Firmware
Version Code: XX

8.1.1 Firmware Version '00'

R41Z modules marked with firmware version '00' are not loaded with a firmware image at the factory. Note: when the R41Z does not have a firmware image loaded that can be executed out of POR, the R41Z module will re-assert POR.

8.2 Mac Address Info

On R41Z modules, the MAC address is typically located in flash as part of the firmware image and is typically accessed as a global constant. Rigado provides a unique MAC address which may be used in an end application. The MAC address is printed on a 2D barcode and human readable text on the top of the module.



MAC Address:
 94:54:93:XX:YY:ZZ

Figure 9 - R41Z MAC Address on Label

When loading custom firmware to the module, the MAC address must be inserted into the image. This can be done manually using the human readable text or automated using a barcode scanner and suitable factory programmer tools. When loading a new application to the module care should be taken to ensure the Rigado bootloader (if used) and MAC address are not overwritten.

9. Mechanical Data

9.1 Package Dimensions

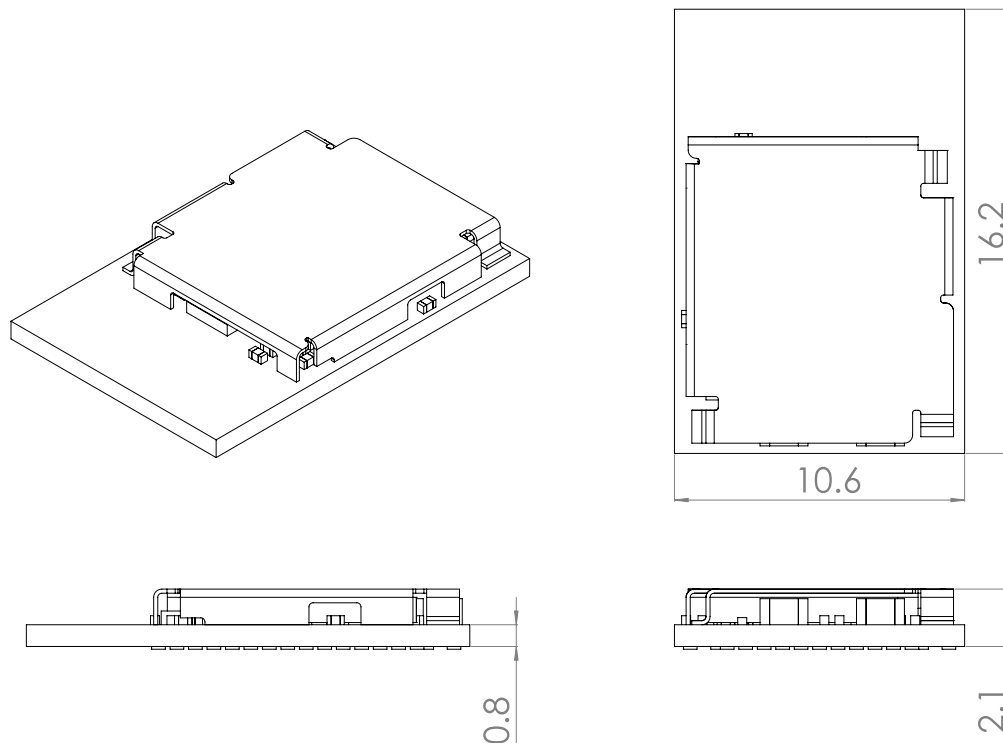

Figure 10 - R41Z Module Dimensions

(All dimensions are in mm)

9.2 Recommended PCB Footprint

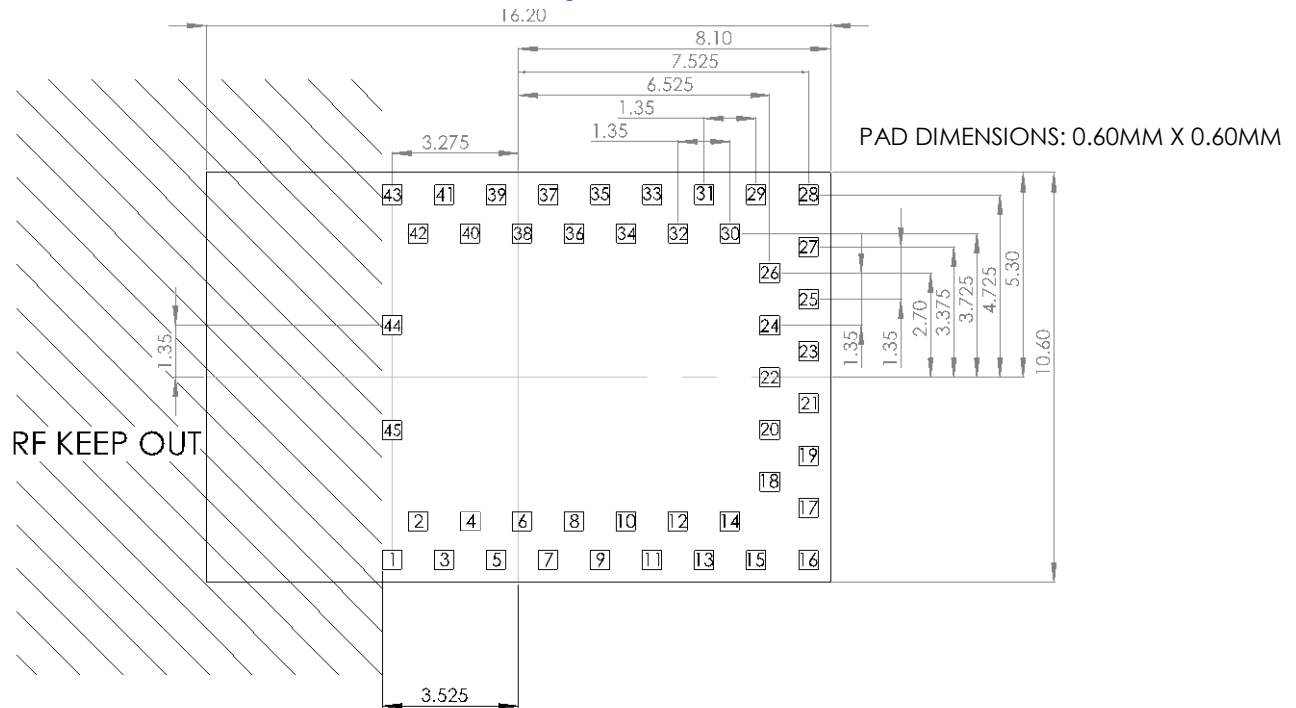

Figure 11 - R41Z Pad Layout (Top View)

(All dimensions are in mm)

10. Module Marking



Figure 12 - R41Z Module Marking - ENG Rev2

11. RF Design Notes

11.1 Recommended RF layout and Ground Plane

The integrated antenna on the R41Z module requires a suitable ground plane to radiate effectively. The module antenna has been tuned for having a PCB directly below with no copper or any other metal present. The module should be placed at the edge of the PCB with the antenna edge facing out. For best performance, the ground plane should be on the same layer as the module or as close as possible. If this is not possible in a design, ground planes on multiple layers generously connected with vias may also be used. Reduced ground plane size will result in reduced radio performance.

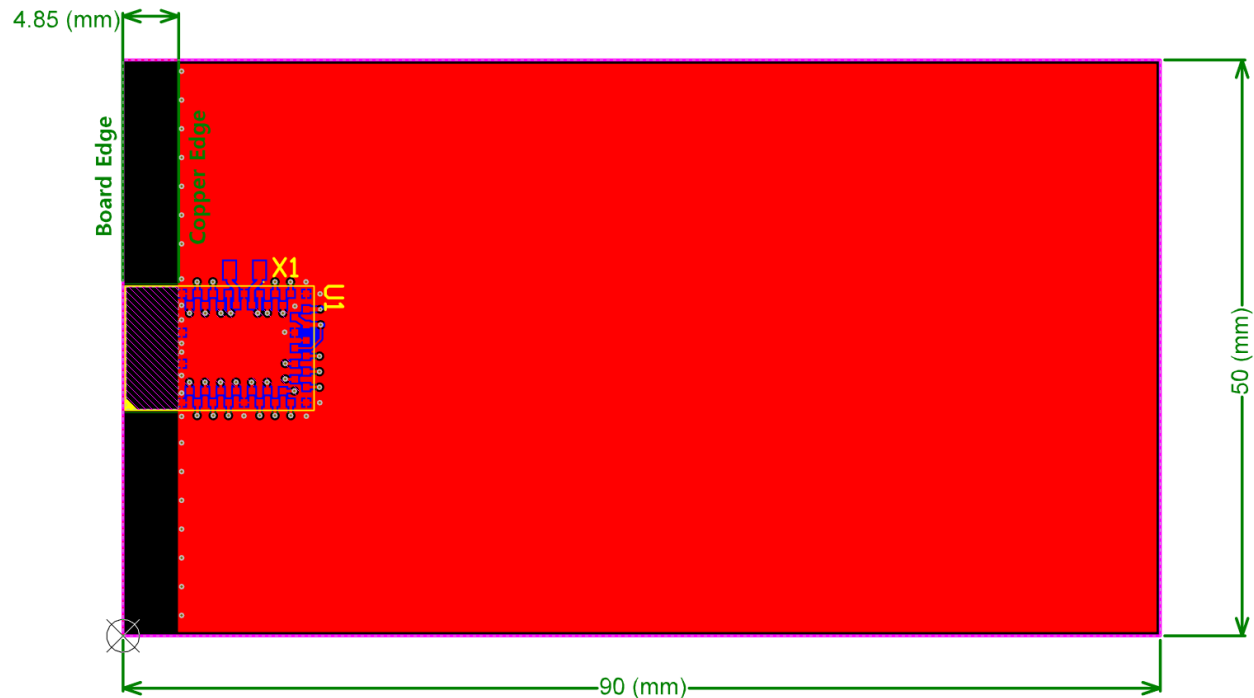

Figure 13 - R41Z RF Example Based on EVAL Board

11.2 Mechanical Enclosure

Care should be taken when designing and placing the module into an enclosure. Metal should be kept clear from the antenna area, both above and below. Any metal around the module can decrease RF performance.

The module is designed and tuned to be in free air. Any potting, epoxy fill, plastic over-molding, or conformal coating can negatively impact RF performance and must be evaluated by the customer. If potting must be used, the compound should have a low dielectric constant and should be designed for use with 2.4GHz RF electronics.

11.3 Antenna Patterns

11.3.1 X-Y Plane

TBD

11.3.2 Y-Z Plane

TBD

11.3.3 Z-X Plane

TBD

12. Evaluation Boards

Rigado has developed a full featured evaluation board that provides on-board programming and debug, power and virtual COM port over USB, 32.768kHz crystal, Arduino style IO headers 2 mechanical user buttons, 2 capacitive touch buttons, 3-axis accelerometer/magnetometer (I²C), and a 4Mbit flash chip (SPI). The evaluation board also allows for easy use of all of the R41Z's DCDC power modes and can be powered from an adjustable LDO regulator, CR2032 coin cell battery, or through an external power header. Power consumption can be measured through onboard current sensing resistors and headers.

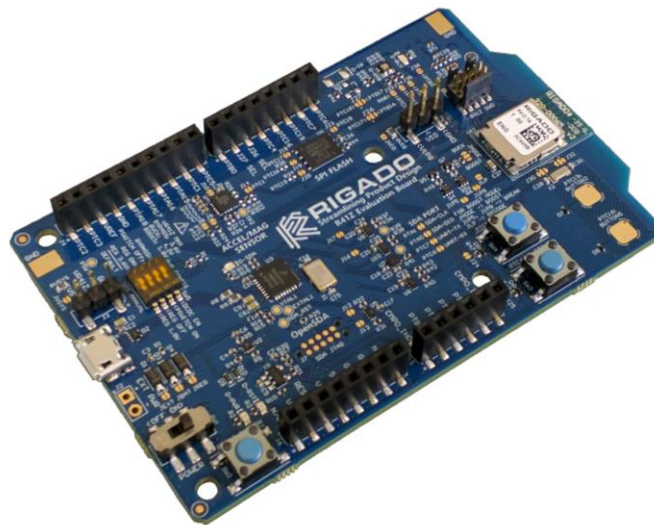
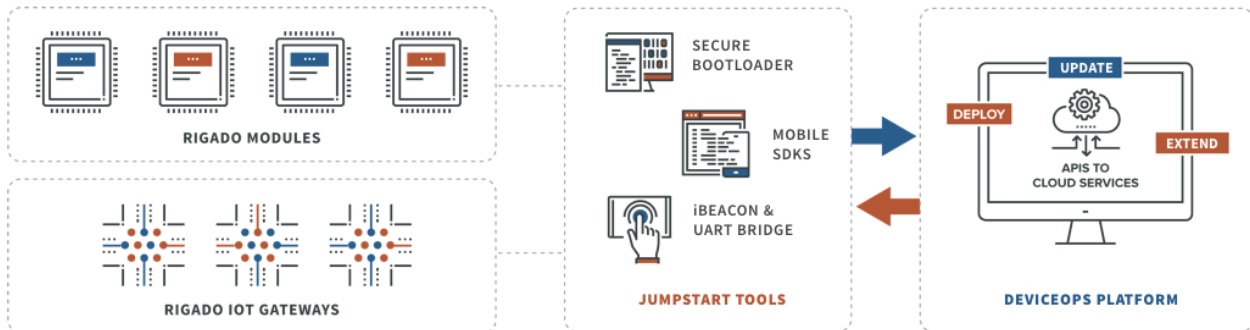

Figure 14 - R41Z Evaluation Board

13. Custom Development

Rigado is a full-service design house offering end-to-end product development from concept to manufacturing. We can provide custom modules, perform electrical and mechanical design, end product manufacturing, firmware and mobile development, and DevOps management tools.



14. Bluetooth Qualification

The R41Z module is being qualified as a Bluetooth Component (tested) for RF-PHY. This allows for customers to use qualified NXP Bluetooth stacks without the need to complete additional RF-PHY testing.

- R41Z: Declaration ID **TBD** / QDID **TBD**

15. Regulatory Statements

15.1 FCC Statement

This device has been tested and found to comply with part 15 of the FCC rules. These limits are designed to provide reasonable protection against harmful interference in a residential installation. This equipment generates, uses and can radiate radio frequency energy and, if not installed and used in accordance with the instructions, may cause harmful interference to radio communications. However, there is no guarantee that interference will not occur in a particular installation. If this equipment does cause harmful interference to radio or television reception, which can be determined by turning the equipment off and on, the user is encouraged to try to correct the interference by one or more of the following measures:

- Reorient or relocate the receiving antenna.
- Increase the separation between the equipment and the receiver
- Connect the equipment into an outlet on a circuit different from that to which the receiver is connected.
- Consult the dealer or an experienced radio/TV technician for help.

Operation is subjected to the following two conditions: (1) This device may no cause harmful interference, and (2) this device must accept any interference received, including interference that may cause undesired operation. Note: Modification to this product will void the user's authority to operate this equipment.

Note: Modification to this product will void the users' authority to operate this equipment.

15.2 FCC Important Notes:

(1) FCC Radiation Exposure Statement

This equipment complies with FCC RF radiation exposure limits set forth for an uncontrolled environment. This transmitter must not be co-located or operating in conjunction with any other antenna or transmitter.

This equipment complies with Part 15 of the FCC Rules. Operation is subject the following two conditions:

- (1) This device may not cause harmful interference, and
- (2) This device must accept any interference received, including interference that may cause undesired operation.

The devices must be installed and used in strict accordance with the manufacturer's instructions as described in this document.

Caution!

The manufacturer is not responsible for any radio or TV interference caused by unauthorized modifications to this equipment. Such modification could void the user authority to operate the equipment.

(2) Co-location Warning:

This device and its antenna(s) must not be co-located or operating in conjunction with any other transmitter antenna.

(3) OEM integration instructions:

This device is intended only for OEM integrators under the following conditions:

The antenna and transmitter must not be co-located with any other transmitter or antenna. The module shall be only used with the integral antenna(s) that has been originally tested and certified with this module.

As long as the two (2) conditions above are met, further transmitter testing will not be required. However, the OEM integrator is still responsible for testing their end-product for any additional compliance requirements with this module installed (for example, digital device emission, PC peripheral requirements, etc.)

In the event that these conditions cannot be met (for example certain laptop configuration or co-location with another transmitter), then the FCC authorization for this module in combination with the

host equipment is no longer considered valid and the FCC ID of the module cannot be used on the final product. In these and circumstance, the OEM integrator will be responsible for re-evaluating. The end product (including the transmitter) and obtaining a separate FCC authorization.

Caution!

The OEM is still responsible for verifying compliance with FCC Part 15, subpart B limits for unintentional radiators through an accredited test facility.

(4) End product labeling:

The final end product must be labeled in a visible area with the following:

- “Contains **FCC ID: 2AA9B07**”
- Any similar wording that expresses the same meaning may be used.

The FCC Statement below should also be included on the label. When not possible, the FCC Statement should be included in the User Manual of the host device.

“This device complies with part 15 of the FCC rules.

Operation is subject to the following two conditions. (1) This device may not cause harmful interference. (2) This device must accept any interference received, including interference that may cause undesired operation.”

(5) Information regarding the end user manual :

The OEM integrator has to be aware not to provide information to the end user regarding how to install or remove this RF module in the user’s manual of the end product which integrates this module. The end user manual shall include all required regulatory information/warning as show in this manual (Section 15.2(4)).

15.3 IC Statement:

This device complies with Industry Canada license-exempt RSS standard(s). Operation is subject to the following two conditions: (1) this device may not cause interference, and (2) this device must accept any interference, including interference that may cause undesired operation of the device.

Le présent appareil est conforme aux CNR d'Industrie Canada applicables aux appareils radio exempts de licence. L'exploitation est autorisée aux deux conditions suivantes : (1) l'appareil ne doit pas produire de brouillage, et (2) l'utilisateur de l'appareil doit accepter tout brouillage radioélectrique subi, même si le brouillage est susceptible d'en compromettre le fonctionnement.

RF exposure warning: The equipment complies with RF exposure limits set forth for an uncontrolled environment. The antenna(s) used for this transmitter must not be co-located or operating in conjunction with any other antenna or transmitter.

Avertissement d'exposition RF: L'équipement est conforme aux limites d'exposition aux RF établies pour un environnement non contrôlé. L'antenne (s) utilisée pour ce transmetteur ne doit pas être co-localisée ou fonctionner en conjonction avec toute autre antenne ou transmetteur.

15.4 IC Important Notes:

1. The OEM integrator has to be aware not to provide information to the end user regarding how to install or remove this RF module in the user manual of the end product.

The user manual which is provided by OEM integrators for end users must include the following information in a prominent location.

2. To comply with IC RF exposure compliance requirements, the antenna used for this transmitter must not be co-located or operating in conjunction with any other antenna or transmitter, except in accordance with IC multi-transmitter product procedures.

3. The final system integrator must ensure there is no instruction provided in the user manual or customer documentation indicating how to install or remove the transmitter module except such device has implemented two-way authentication between module and the host system.

4. The host device shall be properly labelled to identify the module within the host device. The final end product must be labeled in a visible area with the following:

“Contains IC: 12208A-07”

Any similar wording that expresses the same meaning may be used.

The IC Statement below should also be included on the label. When not possible, the IC Statement should be included in the User Manual of the host device.

“This device complies with Industry Canada license-exempt RSS standard(s). Operation is subject to the following two conditions: (1) this device may not cause interference, and (2) this device must accept any interference, including interference that may cause undesired operation of the device.

Le présent appareil est conforme aux CNR d'Industrie Canada applicables aux appareils radio exempts de licence. L'exploitation est autorisée aux deux conditions suivantes : (1) l'appareil ne doit pas produire de brouillage, et (2) l'utilisateur de l'appareil doit accepter tout brouillage radioélectrique subi, même si le brouillage est susceptible d'en compromettre le fonctionnement.”

15.5 CE Regulatory:

The R41Z modules are being tested and expected to be compliant against the following standards. OEM integrators should consult with qualified test house to verify all regulatory requirements have been met for their complete device.

From Directive 2006/95/EC:

- EN 60950-1: 2006 + A11: 2009 + A1: 2010 + A12: 2011

From R&TTE Directive 1999/5/EC:

- ETSI EN 300 328 V 1.9.1

From Directive 2004/108/EC:

- ETSI EN 301 489-1 V1.9.2
- ETSI EN 301 489-17 V2.2.1

Declarations of Conformity and supporting test reports are available at www.rigado.com.

15.6 Japan (MIC)

The R41Z Series modules are pending type certification and are to be labeled with its own technical conformity mark and certification number as required to conform to the technical standards regulated by the Ministry of Internal Affairs and Communications (MIC) of Japan pursuant to the Radio Act of Japan. Integration of this module into a final end product does not require additional radio certification provided installation instructions are followed and no modifications of the module are allowed.

Additional testing may be required:

- If the host product is subject to electrical appliance safety (for example, powered from an AC mains), the host product may require Product Safety Electrical Appliance and Material (PSE) testing. The integrator should contact their conformance laboratory to determine if this testing is required.
- There is a voluntary Electromagnetic Compatibility (EMC) test for the host product administered by VCCI: http://www.vcci.jp/vcci_e/index.html

The label on the final end product which contains a R41Z Series module must follow the MIC marking requirements. Labeling requirements for Japan available at the Ministry of Internal Affairs and Communications (MIC) website: <http://www.tele.soumu.go.jp/e/index.htm>.

The R41Z module is to be labeled with its assigned technical conformity mark and certification number. The final end product in which this module is being used must have an external label referring to the type certified module inside:

Contains transmitter module with certificate number:



15.7 Australia / New Zealand

The R41Z module have been tested to comply with the AS/NZS 4268 :2012+AMDT 1:2013, Radio equipment and systems – Short range devices – Limits and methods of measurement. The report (Pending) may be downloaded from www.rigado.com, and may be used as evidence in obtaining permission to use the RCM.

Information on registration as a Responsible Party, license and labeling requirements may be found at the following websites:

Australia: <http://www.acma.gov.au/theACMA/radiocommunications-short-range-devices-standard-2004>

New Zealand: <http://www.rsm.govt.nz/compliance>

The A-Tick and C-Tick marks are being migrated to the Regulatory Compliance Mark (RCM). Only Australian-based and New Zealand-based companies who are registered may be granted permission to use the RCM. An Australian-based or New Zealand-based agent or importer may also register as a Responsible Party to use the RCM on behalf of a company not in Australia or New Zealand.

16. Solder Reflow Temperature-Time Profile

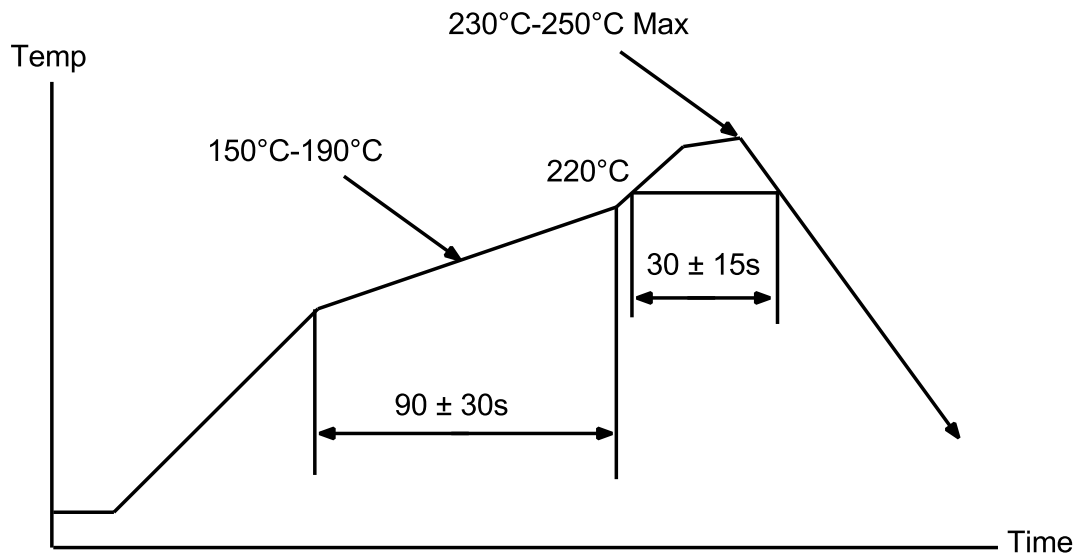

Figure 15 - Reflow Profile for Lead Free Solder

16.1 Moisture Sensitivity Level

The R41Z module is rated for MSL 3, 168-hour floor life after opening.

17. Packaging and Labeling

17.1 Carrier Tape Dimension

TBD

17.2 Reel Packaging

Modules come on 330mm reels loaded with 1000 modules. Each reel is placed in an antistatic bag with a desiccant pack and humidity card and placed in a 340x350x65mm box. On the outside of the bag an antistatic warning and reel label are adhered.

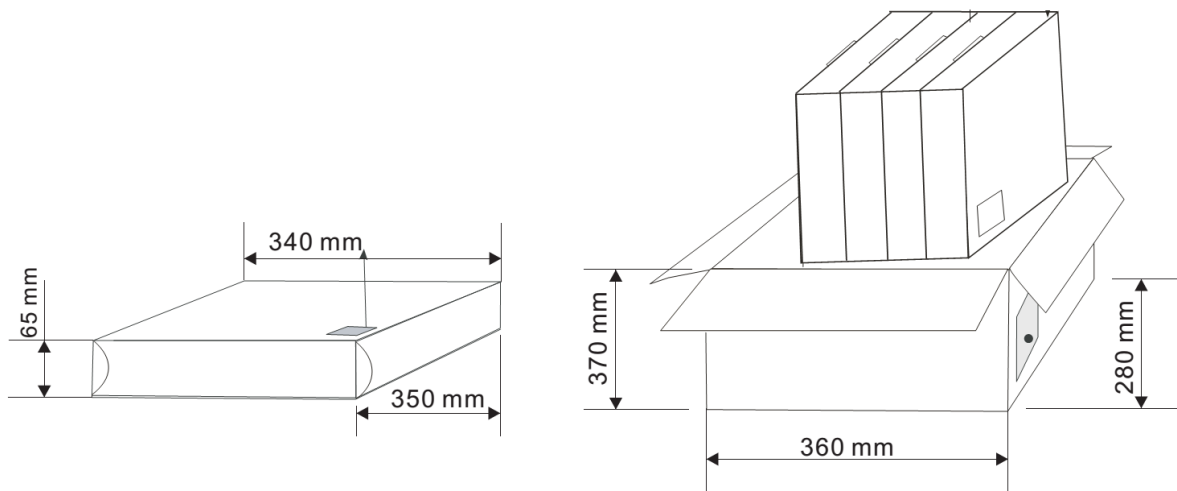

Figure 16 - Reel Cartons

17.3 Packaging Label



Figure 17 - Packaging Label

18. Cautions

- 1) The guidelines of this document should be followed in order to assure proper performance of the module.
- 2) This product is for use in office, business, and residential applications, but not medical devices.
- 3) This module may short-circuit. If a short circuit can result in serious damage or injury then failsafe precautions should be used. This could be accomplished by redundant systems and protection circuits.
- 4) Supply voltage to the module should not be higher than the specified inputs or reversed. Additionally, it should not contain noise, spikes, or AC ripple voltage.
- 5) Avoid use with other high frequency circuits.
- 6) Use methods to eliminate static electricity when working with the module as it can damage the components.
- 7) Contact with wires, the enclosure, or any other objects should be avoided.
- 8) Refer to the recommended pattern when designing for this module.
- 9) If hand soldering is used, be sure to use the precautions outlined in this document.
- 10) This module should be kept away from heat, both during storage and after installation.
- 11) Do not drop or physically shock the module.
- 12) Do not damage the interface surfaces of the module.
- 13) The module should not be mechanically stressed at any time (storage, handling, installation).
- 14) Do not store or expose this module to:
 - Humid or salty air conditions
 - High concentrations of corrosive gasses.
 - Long durations of direct sunlight.
 - Temperatures lower than -40°C or higher than 125°C.

19. Life Support Policy

This product is not designed to be used in a life support device or system, or in applications where there is potential for a failure or malfunction to, directly or indirectly, cause significant injury. By using this product in an application that poses these risks, such as described above, the customer is agreeing to indemnify Rigado for any damages that result.

20. Document History

Revision	Date	Changes / Notes
0.9	10/20/2016	Release draft. Images and specifications updated.
1.0	11/17/2016	Certifications added

21. Related Documents

Rigado Documents:

- [R41Z Module Product Brief](#)

NXP Documents:

- [KW41Z Fact Sheet](#)
- [NXP BLE Mobile Toolbox](#)
- [KW41Z Data Sheet](#)
- [KW41Z Reference Manual](#)