

# EMMY-W1 series

## Host-based multiradio modules with Wi-Fi, Bluetooth and NFC

### User Manual

#### Abstract

This technical data sheet describes the EMMY-W1 series modules with Wi-Fi 802.11ac, Bluetooth v4.2 (Bluetooth® Smart Ready) and Near-Field Communication (NFC) designed for both simultaneous and independent operations. These modules include an integrated MAC/baseband processor and RF front-end components and can connect to a host processor through SDIO 3.0 or high-speed UART interfaces. A PCM interface is available for Bluetooth audio applications. These modules are offered in both professional and automotive grades.

[www.u-blox.com](http://www.u-blox.com)

UBX-16015271 - R03

**Document Information**

<b>Title</b>	<b>EMMY-W1 series</b>		
<b>Subtitle</b>	Host-based multiradio modules with Wi-Fi, Bluetooth and NFC		
<b>Document type</b>	User Manual		
<b>Document number</b>	UBX-16015271		
<b>Revision and date</b>	R03	05-July-2016	
<b>Document status</b>	Product Information		

**Document status explanation**

Objective Specification	Document contains target values. Revised and supplementary data will be published later.
Advance Information	Document contains data based on early testing. Revised and supplementary data will be published later.
Early Production Information	Document contains data from product verification. Revised and supplementary data may be published later.
Production Information	Document contains the final product specification.

**This document applies to the following products:**

Product name	Type number	ROM/FLASH version	PCN / IN reference
EMMY-W161	EMMY-W161-00B-00	EMMY-W161-00B	N/A
EMMY-W161-A	EMMY-W161-00A-00	EMMY-W161-00A	N/A
EMMY-W163	EMMY-W163-00B-00	EMMY-W163-00B	N/A
EMMY-W163-A	EMMY-W163-00A-00	EMMY-W163-00A	N/A
EMMY-W165	EMMY-W165-00B-00	EMMY-W165-00B	N/A
EMMY-W165-A	EMMY-W165-00A-00	EMMY-W165-00A	N/A

u-blox reserves all rights to this document and the information contained herein. Products, names, logos and designs described herein may in whole or in part be subject to intellectual property rights. Reproduction, use, modification or disclosure to third parties of this document or any part thereof without the express permission of u-blox is strictly prohibited.

The information contained herein is provided "as is" and u-blox assumes no liability for the use of the information. No warranty, either express or implied, is given, including but not limited, with respect to the accuracy, correctness, reliability and fitness for a particular purpose of the information. This document may be revised by u-blox at any time. For most recent documents, visit [www.u-blox.com](http://www.u-blox.com).

Copyright © 2016, u-blox AG.

u-blox® is a registered trademark of u-blox Holding AG in the EU and other countries. ARM® is the registered trademark of ARM Limited in the EU and other countries.

# Contents

<b>Contents.....</b>	<b>3</b>
<b>1 Functional description.....</b>	<b>5</b>
1.1 Overview .....	5
1.2 Applications.....	5
1.3 Product features.....	6
1.4 Block diagrams.....	6
1.5 Product description .....	7
1.6 Supported features.....	8
1.6.1 Wi-Fi features.....	8
1.6.2 Bluetooth features.....	8
1.6.3 NFC features.....	8
1.6.4 General product features.....	8
1.6.5 Compliance .....	9
1.7 Additional reserved MAC addresses .....	9
<b>2 Interfaces.....</b>	<b>10</b>
2.1 Operation mode configuration.....	10
2.2 SDIO interface.....	10
2.2.1 Default speed and High speed modes.....	10
2.2.2 SDR12, SDR25, SDR50 Modes (up to 100 MHz) (1.8 V) .....	11
2.2.3 SDR104 Mode (208 MHz) (1.8 V) .....	12
2.2.4 DDR50 Mode (50 MHz) (1.8 V).....	13
2.3 High Speed UART interface.....	14
2.4 PCM interface.....	15
2.4.1 PCM interface specifications .....	15
2.5 GPIO interface.....	16
<b>3 Pin Definition.....</b>	<b>18</b>
3.1 Pin description .....	18
3.2 Reset configuration .....	19
<b>4 Electrical specification .....</b>	<b>20</b>
4.1 Absolute maximum ratings .....	20
4.2 Operating conditions.....	20
4.3 Digital pin ratings.....	21
4.4 Wi-Fi power consumption.....	21
4.5 Bluetooth power consumption.....	22
4.6 NFC power consumption .....	22
4.7 Radio specifications.....	23
4.7.1 Wi-Fi.....	23
4.7.2 Bluetooth.....	28

4.7.3	LTE co-existence.....	28
4.7.4	Near field communication.....	28
<b>5</b>	<b>Host drivers and firmware.....</b>	<b>30</b>
5.1	General principle.....	30
5.2	Supported operating systems.....	30
5.2.1	Linux.....	30
<b>6</b>	<b>Mechanical specifications.....</b>	<b>31</b>
<b>7</b>	<b>Qualification and approvals.....</b>	<b>32</b>
7.1	Approvals.....	32
7.1.1	European Union regulatory compliance.....	32
7.1.2	FCC compliance.....	33
7.1.3	IC compliance.....	34
7.2	Approved antennas.....	35
7.2.1	Bluetooth antenna.....	36
7.2.2	NFC antenna.....	36
7.3	FCC and IC IDs (planned).....	36
7.4	Certification in other countries.....	36
<b>8</b>	<b>Product handling.....</b>	<b>37</b>
8.1	Packaging.....	37
8.1.1	Reels.....	37
8.1.2	Tapes.....	37
8.2	Shipment, storage and handling.....	37
8.2.1	Moisture sensitivity levels.....	37
8.2.2	Mounting process and soldering recommendations.....	38
8.2.3	ESD handling precautions.....	39
<b>9</b>	<b>Labeling and ordering information.....</b>	<b>40</b>
9.1	Product labeling.....	40
9.2	Explanation of codes.....	41
9.3	Ordering codes.....	41
<b>Appendix.....</b>	<b>42</b>	
<b>A Glossary.....</b>	<b>42</b>	
<b>Related documents.....</b>	<b>44</b>	
<b>Revision history.....</b>	<b>45</b>	
<b>Contact.....</b>	<b>46</b>	

# 1 Functional description

## 1.1 Overview

The EMMY-W1 series provides a complete short range transceiver solution that can easily be integrated into automotive and industrial applications. The modules are designed for both simultaneous and independent operation of the following technologies:

- IEEE 802.11a/b/g/n/ac payload data rates for Wi-Fi
- Dual-mode Bluetooth v4.2
- NFC

The EMMY-W1 series is a surface-mount device (SMD) component and can be used as a Wi-Fi micro-access point supporting up to 10 clients. A coexistence feature on chip level improves parallel use of Bluetooth and Wi-Fi communication. For highest throughput and performance, a module variant with separated Wi-Fi and Bluetooth antenna pin is also available.

The modules include an integrated MAC/baseband processor and RF front-end components and can connect to a host processor through SDIO 3.0 and high-speed UART interfaces. The EMMY-W1 series are offered in automotive and professional grades (see 9.3 Ordering codes and 1.4 Block diagrams). The automotive grade variant includes an automotive-qualified (AEC-Q100) chipset. A host driver for Linux 3.x is available free of charge. The modules are radio type approved<sup>1</sup> for Europe (ETSI R&TTE), US (FCC CFR 47 part 15 unlicensed modular transmitter approval) and Canada (IC RSS). Regulatory approvals for using this module in Japan, South Korea, China, Taiwan and Australia will follow.

## 1.2 Applications

### Automotive applications

- High definition (HD) video streaming (headrest displays, rear-view camera) and in-car gaming
- Rapid sync-n-go applications and fast content download to the vehicle
- Hands-free equipment (Bluetooth)
- Personalized adjustment of comfort functions through NFC

### Industrial applications

- Manufacturing floor automation, wireless control terminals and point-to-point backhaul
- Outdoor content distribution
- Mobile video streaming
- Robust wireless connectivity in a broad range of industrial applications

---

<sup>1</sup> Approvals are pending

### 1.3 Product features

Model	Radio	Interfaces	Power	Connectors	Features	Grade
	Wi-Fi 2.4 GHz channels 1-13 Wi-Fi 5 GHz channels 36-165 Wi-Fi IEEE 802.11 version NFC Bluetooth qualification Bluetooth profiles Max output power at antenna pin Antenna type LTE filter High-speed UART SDIO 3.0 PCM (Bluetooth audio)		Power supply: 3.0-3.6 V	Solder pins	Micro Access Point AES hardware support RF parameters in OTP memory MAC addresses in OTP memory	Standard Professional Automotive
<b>EMMY-W161</b>	• a/b/g/n/ac • v4.2 H 18 dBm 1p	• • •	•	•	• • • •	
<b>EMMY-W163</b>	• a/b/g/n/ac • v4.2 H 18 dBm 2p	• • •	•	•	• • • •	
<b>EMMY-W165</b>	• a/b/g/n/ac • v4.2 H 18 dBm 1p	• • •	•	•	• • • •	

H = HCI  
 1p = One pin for combined external antenna for Bluetooth and Wi-Fi  
 2p = Two pins for separate external antennas for Bluetooth and Wi-Fi

Table 1: EMMY-W1 series main features summary

### 1.4 Block diagrams

The block diagrams of the EMMY-W1 series are provided in this section.

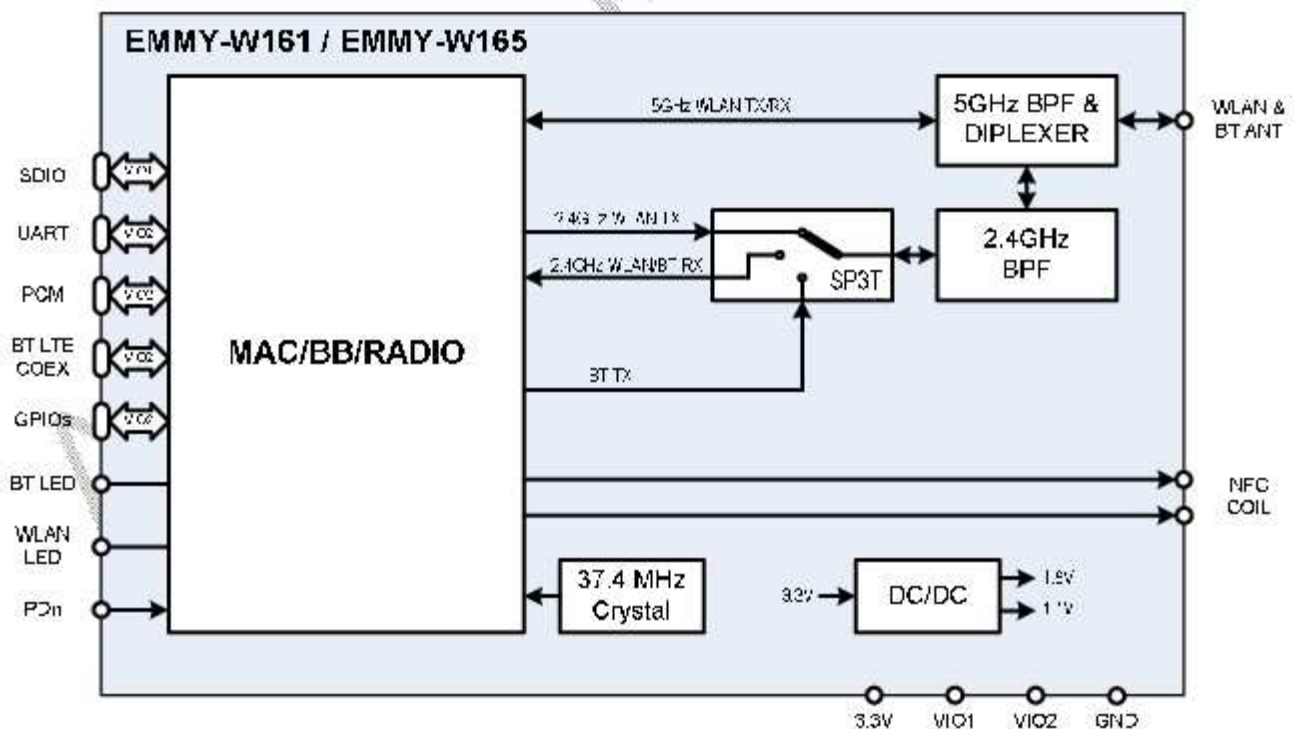

Figure 1: EMMY-W161/EMMY-W165 block diagram - Single antenna variant

**⚠ In EMMY-W161, the band pass filter (2.4 GHz BPF) is a BAW filter that enables co-existence with LTE. For the variant EMMY-W165, the band pass filter provides no co-existence protection against a co-located LTE transmitter.**

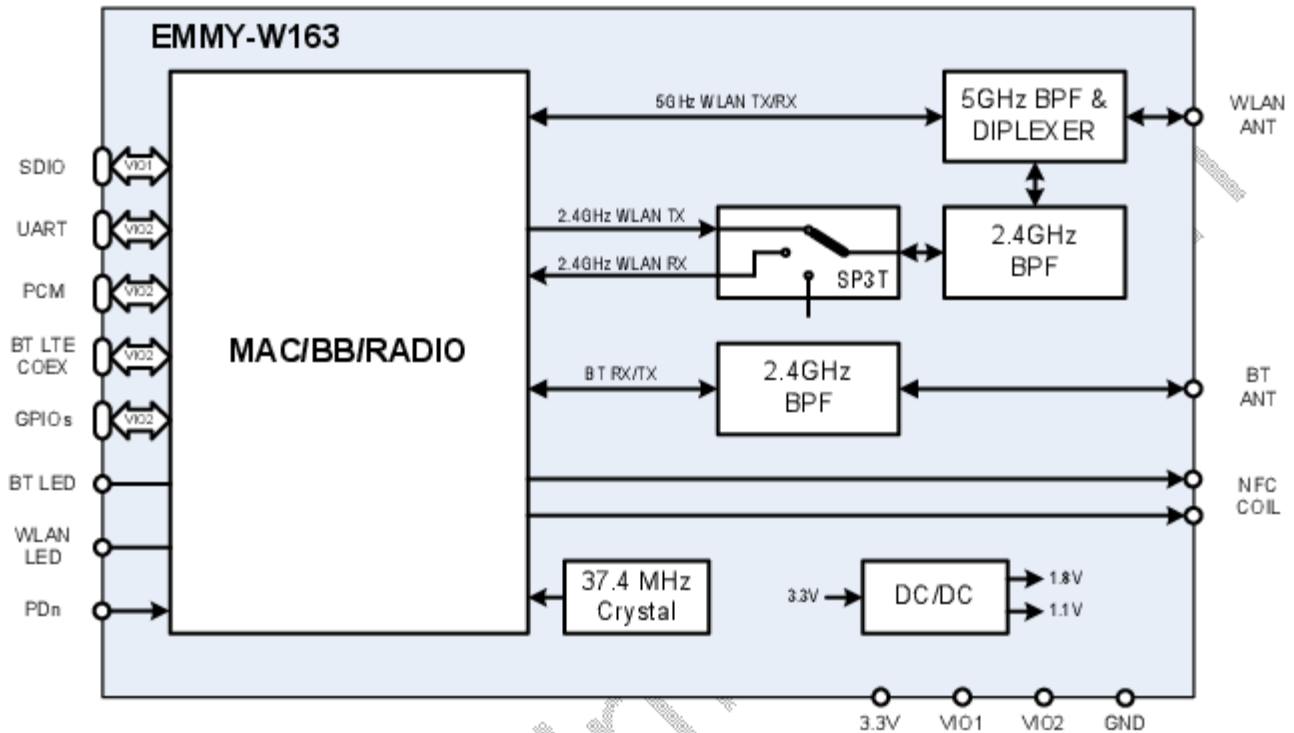

Figure 2: EMMY-W163 block diagram - Dual-antenna variant

**👉** In EMMY-W163, the bandpass filters (2.4 GHz BPF) are ceramic bandpass filters. An LTE co-existence variant is not available in the dual-antenna configuration.

## 1.5 Product description

Model	Description
EMMY-W161	Professional grade module with 1 combined antenna pin for Wi-Fi and Bluetooth and integrated LTE filter
EMMY-W163	Professional grade module with 2 separate antenna pins for Wi-Fi and Bluetooth (no LTE filter)
EMMY-W165	Professional grade module with 1 combined antenna pin for Wi-Fi and Bluetooth (no LTE filter)
EMMY-W161-A	Automotive grade module with 1 combined antenna pin for Wi-Fi and Bluetooth and integrated LTE filter
EMMY-W163-A	Automotive grade module with 2 separate antenna pins for Wi-Fi and Bluetooth (no LTE filter)
EMMY-W165-A	Automotive grade module with 1 combined antenna pin for Wi-Fi and Bluetooth (no LTE filter)

**👉** The EMMY-W161 is recommended for applications that have co-located Wi-Fi, Bluetooth and LTE antennas and require co-existence of these wireless technologies. This module provides a dedicated BAW bandpass filter instead of the ceramic bandpass filter. This filter rejects the adjacent LTE bands B40, B7, B41 and B38. The integrated BAW filter is available only for the single-antenna configuration (EMMY-W161). The module pinout, operating conditions, and electrical characteristics are identical for all product variants. Differences in the RF parameters are explained in the Radio specifications section.

## 1.6 Supported features

### 1.6.1 Wi-Fi features

- Wi-Fi standards: IEEE 802.11a/b/g/n/ac/d/e/h/i/k<sup>2</sup>/r/v<sup>2</sup>/w
- Simultaneous client and access point operation (up to 10 clients supported)
- Support of Wi-Fi direct mode
- IEEE 802.11ac 1x1 antenna configuration
- IEEE 802.11 PHY data rates up to 433 Mbps
- 64- and 128-bit AES hardware encryption engine
- WAPI encryption is supported by hardware
- SDIO 3.0 host interface for Wi-Fi

### 1.6.2 Bluetooth features

- Bluetooth v4.2 with Bluetooth Low Energy and Classic Bluetooth v2.1+EDR over SDIO or high-speed UART interface
- PCM interface for audio
- MWS/LTE coexistence serial transport interface for connecting an external and co-located LTE device<sup>3</sup>

### 1.6.3 NFC features

- NCI 1.0 support according to NFC Forum specification
- NFC support through SDIO or UART
- Full protocol support for ISO 14443A/B, ISO 15693<sup>4</sup>, ISO 18092, NFCIP-2, NFC forum, EMV contactless targets with data rates up to 848 Kbps
- Deep Sleep
- Proprietary Low-Power Target Detection mode to reduce standby current consumption
- On-Host card emulation: supported in NFC A, B, F and V technologies
- Off-Host card emulation with UICCs and Embedded SEs (availability is package dependent):
  - ETSI TS 102 613: SWP/CLT ISO 14443 Type A (Mifare) and ISO 18093 212/424 kbps passive mode (FeliCa).
  - ETSI TS 102 622: SWP/HCI ISO 14443A/B and ISO 18092 212/424 kbps passive mode
  - DCLB
- Compliant with EMVCo book D (Contactless Communication Protocol)
- Reader/Writer, card emulation, and Peer-to-peer (P2P) modes
- Programmable carrier detection level for card emulation mode
- Programmable field detection level for RF anti-collision when operating as reader or active target
- UART host interface support (shared with Bluetooth when operating)

### 1.6.4 General product features

- Driver support for Linux
- Low-power and sleep modes for Bluetooth and Wi-Fi core
- Coexistence arbitration for Wi-Fi/Bluetooth/LE/NFC/LTE operation
- Small footprint (19.8 mm x 13.8 mm), LGA package
- Product variant with integrated LTE co-location filter available
- Automotive qualification tests (climatic, mechanical, and operating life tests) according ISO 16750-4 planned

<sup>2</sup> Supported by hardware but not supported by firmware currently.

<sup>3</sup> Available on request

<sup>4</sup> For ISO 15693 VICC mode, the maximum supported 10-90% rise/fall times for receiving 10% ASK modulation is 1.18 µs.



### 1.6.5 Compliance

- RoHS compliant
- Radio type approvals for Europe, USA, Canada, Japan, Korea, Taiwan, China and Australia<sup>5</sup>

## 1.7 Additional reserved MAC addresses

The EMMY-W1 module series has four unique consecutive MAC addresses reserved for each module, from which the first two addresses are already stored in the configuration during production. The first address is used for the Bluetooth communication while the second address is configured for Wi-Fi communication. The Data Matrix Code on the label includes the Bluetooth MAC address (see section 9). The remaining two MAC addresses are not used in the manufacturing configuration, but are reserved for usage with the module.

MAC address	Assignment	Last two bits of MAC address	Example
Module1, address 1	Bluetooth	0b00	D4:CA:6E:44:00:04
Module1, address 2	Wi-Fi	0b01	D4:CA:6E:44:00:05
Module1, address 3	(free for use)	0b10	D4:CA:6E:44:00:06
Module1, address 4	(free for use)	0b11	D4:CA:6E:44:00:07
Module2, address 1	Bluetooth	0b00	D4:CA:6E:44:00:08
Module2, address 2	Wi-Fi	0b01	D4:CA:6E:44:00:09
Module2, address 3	(free for use)	0b10	D4:CA:6E:44:00:0A
Module2, address 4	(free for use)	0b11	D4:CA:6E:44:00:0B

**Table 2: MAC address assignment**

<sup>5</sup> Approvals are pending.

## 2 Interfaces

### 2.1 Operation mode configuration

EMMY-W1 series module uses the GPIO\_3 and GPIO\_2 pins as host interface configuration input to set the desired operation mode following a reset. The definitions of these pins are changed to their usual functions after reset. When you need to configure the pins for a certain module operation mode, you need to provide a 100 k $\Omega$  pull down resistor to the ground. No external circuitry is required to set a configuration pin to high logical level.

External reset is not needed for proper operation due to internal power-up reset logic though it can be used by the host controller through the PDn pin (active low) in case of an abnormal module behavior.

After reset, GPIO\_3 and GPIO\_2 pins can be used as open drain outputs (depending on firmware/driver version) for Bluetooth and Wi-Fi activity LED indicators, but simultaneous usage of an LED connected to 3.3 V power line and a pull-down resistor is not allowed (LED acts as a strong pull-up circuitry). Do not connect LED if you need the pull-down resistors.

Depending on the firmware or driver used, you can use either one or both host interface operation modes:

GPIO_3	GPIO_2	Wi-Fi	Bluetooth/NFC	Number of SDIO functions
0	0	SDIO	UART	1 (Wi-Fi)
0	1	SDIO	SDIO	3 (Wi-Fi, Bluetooth and NFC)
1	0	SDIO	UART	1 (Wi-Fi)
1	1	SDIO	SDIO	3 (Wi-Fi, Bluetooth and NFC) <sup>6</sup>

Table 3: Module configuration

### 2.2 SDIO interface

EMMY-W1 series modules support an SDIO device interface that conforms to the industry standard SDIO 3.0 Full-Speed specification (4-bit SDIO up to 208 MHz) and allows a host controller using the SDIO bus protocol to access the Wi-Fi and Bluetooth functions. The interface supports 4-bit SDIO transfer mode at the full clock range of 0 to 208 MHz.

#### 2.2.1 Default speed and High speed modes

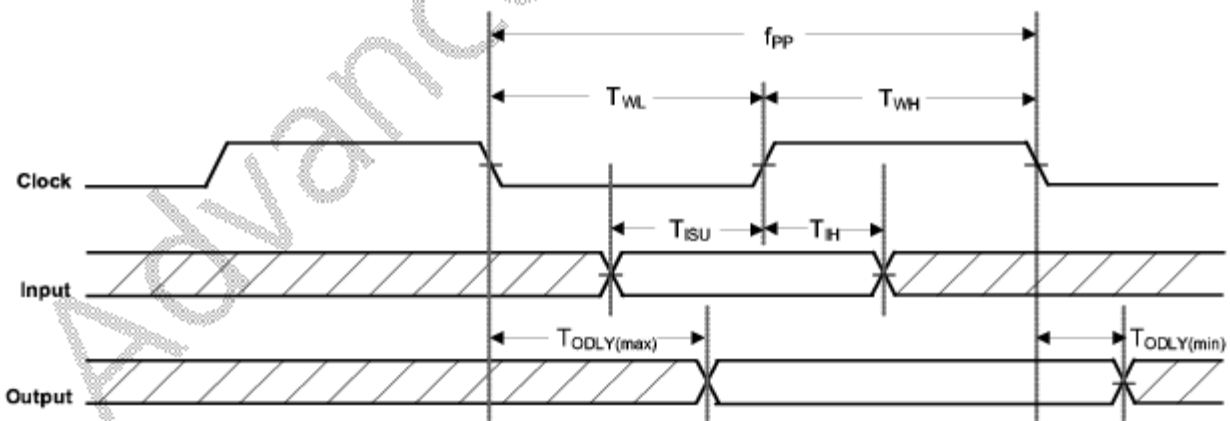

Figure 3: SDIO protocol timing diagram- Default speed mode (3.3 V)

<sup>6</sup> Default configuration. It is possible to use connected LEDs to both the pins.

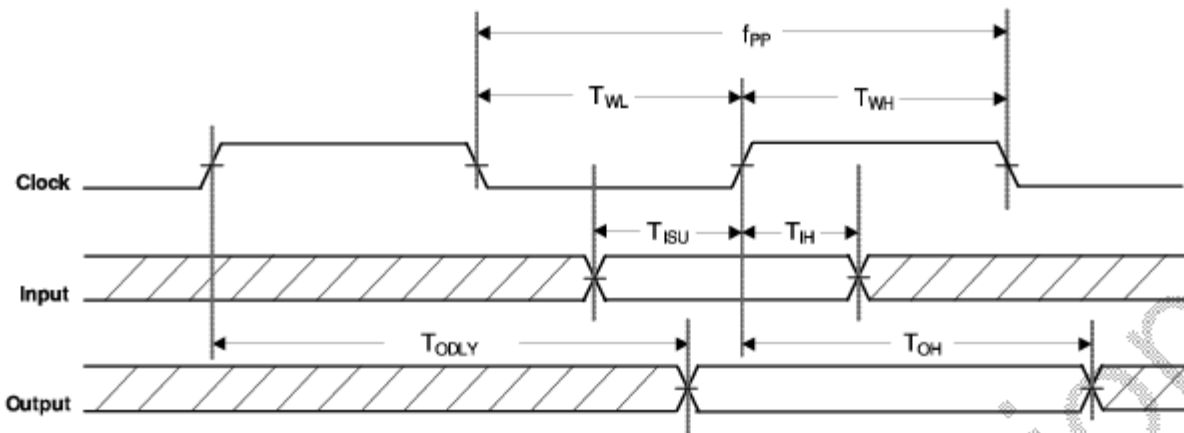

Figure 4: SDIO protocol timing diagram – High speed mode (3.3 V)

Symbol	Parameter	Condition	Min.	Typ	Max.	Units
$f_{PP}$	Clock frequency	Normal	0	-	25	MHz
		High speed	0	-	50	MHz
$T_{WL}$	Clock low time	Normal	10	-	-	ns
		High speed	7	-	-	ns
$T_{WH}$	Clock high time	Normal	10	-	-	ns
		High speed	7	-	-	ns
$T_{ISU}$	Input setup time	Normal	5	-	-	ns
		High speed	6	-	-	ns
$T_{IH}$	Input hold time	Normal	5	-	-	ns
		High speed	2	-	-	ns
$T_{ODLY(V_{DD})}$	Maximal Output delay time	Normal	-	-	14	ns
$T_{ODLY(V_{DD})}$	Minimal Output delay time	Normal	-	-	0	ns
$T_{ODLY}$	Output delay time $CL \leq 40$ pF (1 card)	Normal	-	-	14	ns
$T_{OH}$	Output hold time	High speed	2.5	-	-	ns

Table 4: SDIO timing data – Default speed, High speed modes (3.3 V)

## 2.2.2 SDR12, SDR25, SDR50 Modes (up to 100 MHz) (1.8 V)

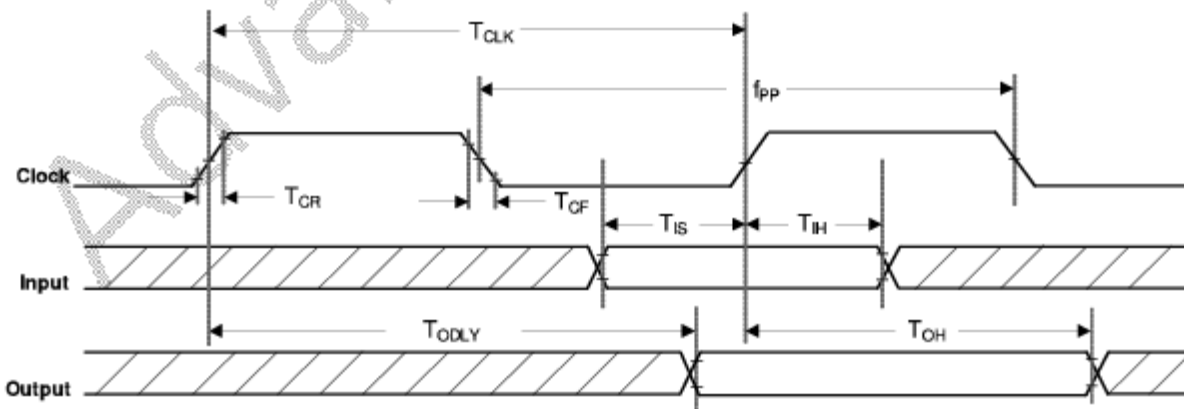
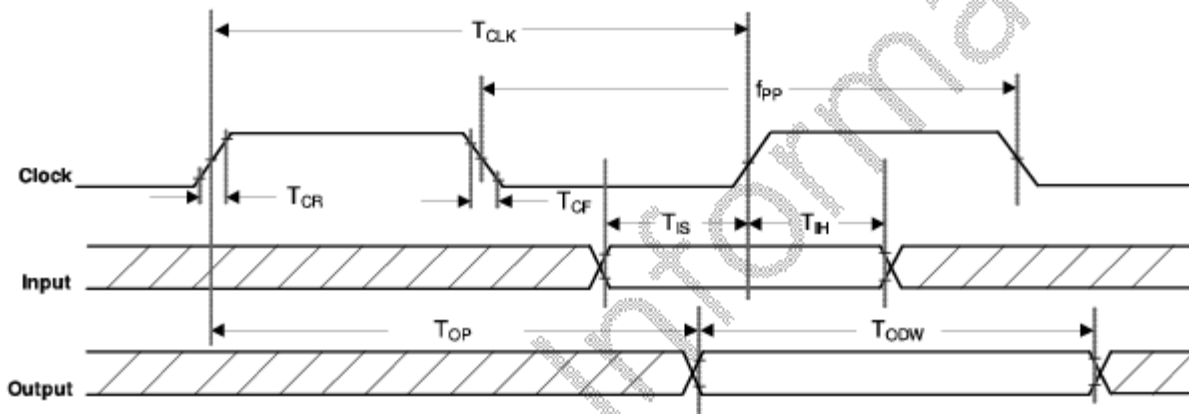

Figure 5: SDIO protocol timing diagram – SDR12, SDR25, SDR50 modes (up to 100 MHz) (1.8 V)

Symbol	Parameter	Condition	Min.	Typ	Max.	Units
$f_{pp}$	Clock frequency	SDR12/25/50	25	-	100	MHz
$T_{IS}$	Input setup time	SDR12/25/50	3	-	-	ns
$T_{IH}$	Input hold time	SDR12/25/50	0.8	-	-	ns
$T_{CLK}$	Clock time	SDR12/25/50	10	-	40	ns
$T_{CR}, T_{CF}$	Rise time, fall time $T_{CR}, T_{CF} < 2$ ns (max) at 100 MHz $C_{CARD} = 10$ pF	SDR12/25/50	-	-	$0.2 * T_{CLK}$	ns
$T_{ODLY}$	Output delay time $C_L \leq 30$ pF	SDR12/25/50	-	-	7.5	ns
$T_{OH}$	Output hold time $C_L = 15$ pF	SDR12/25/50	1.5	-	-	ns

**Table 5: SDIO timing data – SDR12, SDR25, SDR50 modes (up to 100 MHz) (1.8 V)**

### 2.2.3 SDR104 Mode (208 MHz) (1.8 V)

**Figure 6: SDIO protocol timing diagram – SDR104 mode (208 MHz)**

Symbol	Parameter	Condition	Min.	Typ	Max.	Units
$f_{pp}$	Clock frequency	SDR104	0	-	208	MHz
$T_{IS}$	Input setup time	SDR104	1.4	-	-	ns
$T_{IH}$	Input hold time	SDR104	0.8	-	-	ns
$T_{CLK}$	Clock time	SDR104	4.8	-	-	ns
$T_{CR}, T_{CF}$	Rise time, fall time $T_{CR}, T_{CF} < 0.96$ ns (max) at 208 MHz $C_{CARD} = 10$ pF	SDR104	-	-	$0.2 * T_{CLK}$	ns
$T_{OP}$	Card output phase	SDR104	0	-	10	ns
$T_{ODW}$	Output timing of variable data window	SDR104	2.88	-	-	ns

**Table 6: SDIO timing data – SDR104 mode (208 MHz)**

## 2.2.4 DDR50 Mode (50 MHz) (1.8 V)

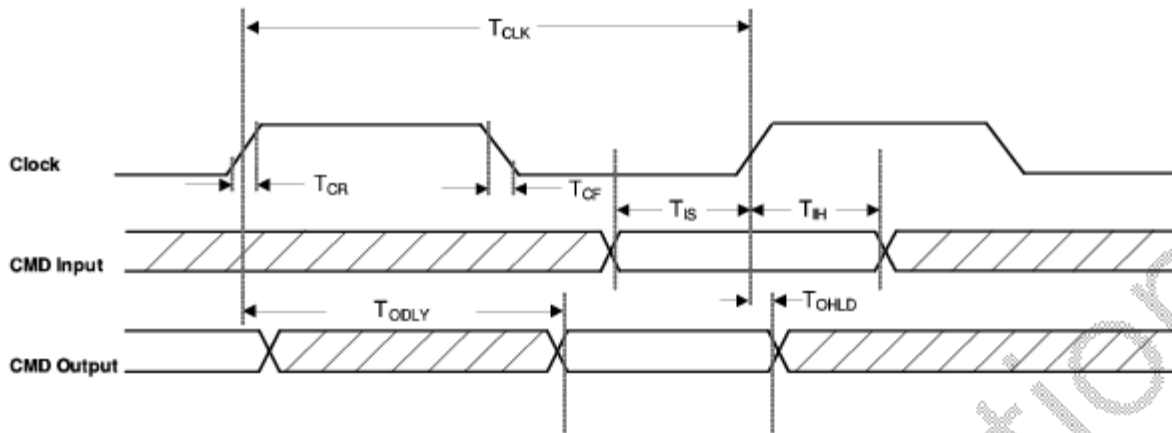
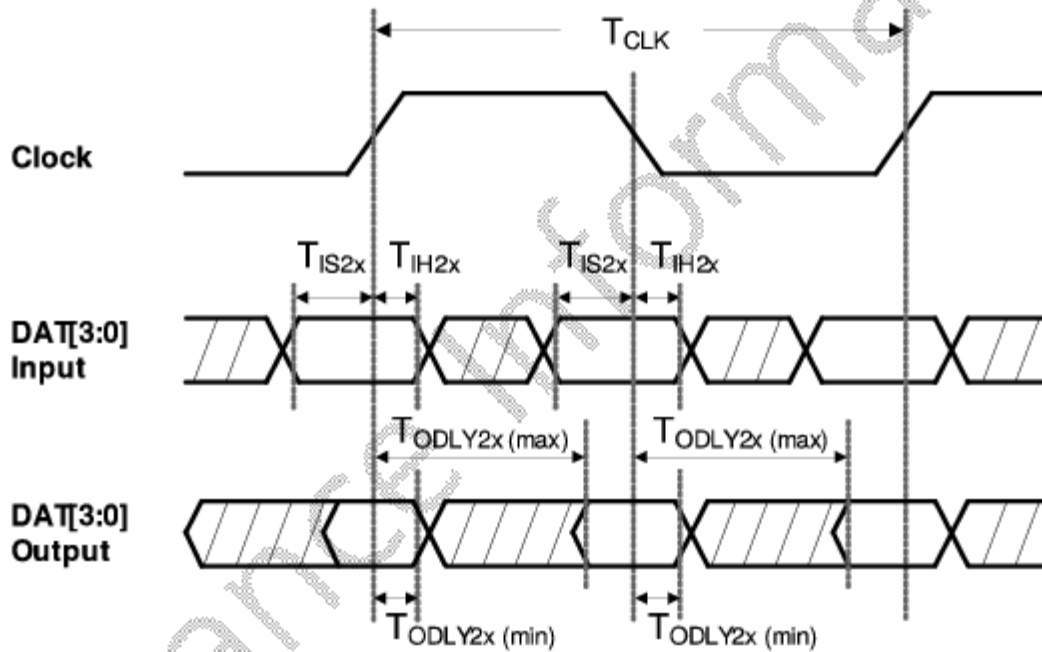

Figure 7: SDIO CMD timing diagram – DDR50 mode (50 MHz)



- In DDR50 mode, DAT[3:0] lines are sampled on both edges of the clock (not applicable for CMD line).

Figure 8: SDIO DAT[3:0] timing diagram – DDR50 mode (50 MHz)

Symbol	Parameter	Condition	Min.	Typ	Max.	Units
<b>Clock</b>						
$T_{CLK}$	Clock time 50 MHz (max) between rising edges	DDR50	20			ns
$T_{CR}, T_{CF}$	Rise time, fall time $T_{CR}, T_{CF} < 4.00$ ns (max) at 50 MHz $C_{CARD} = 10$ pF	DDR50			$0.2 * T_{CLK}$	ns
Clock Duty		DDR50	45		55	%
<b>CMD Input (referenced to clock rising edge)</b>						
$T_{IS}$	Input setup time $C_{CARD} \leq 10$ pF (1 card)	DDR50	6			ns
$T_{IH}$	Input hold time $C_{CARD} \leq 10$ pF (1 card)	DDR50	0.8			ns
<b>CMD Output (referenced to dock rising edge)</b>						
$T_{OOLY}$	Output delay time during data transfer mode $C_L \leq 30$ pF (1 card)	DDR50			13.7	ns
$T_{OHLD}$	Output hold time $C_L \geq 15$ pF (1 card)	DDR50	1.5			ns
<b>DAT[3:0] Input (referenced to clock rising and falling edges)</b>						
$T_{IS2a}$	Input setup time $C_{CARD} \leq 10$ pF (1 card)	DDR50	3			ns
$T_{IH2a}$	Input hold time $C_{CARD} \leq 10$ pF (1 card)	DDR50	0.8			ns
<b>DAT[3:0] Output (referenced to clock rising and falling edges)</b>						
$T_{OOLY2a(Y.a)}$	Output delay time during data transfer mode $C_L \leq 25$ pF (1 card)	DDR50			7.0	ns
$T_{OOLY2a(Y.b)}$	Output hold time $C_L \geq 15$ pF (1 card)	DDR50	1.5			ns

**Table 7: SDIO timing data – DDR50 mode (50 MHz)**

## 2.3 High Speed UART interface

The EMMY-W1 series modules support a high speed Universal Asynchronous Receiver/Transmitter (UART) interface in compliance with the industry standard 16550 specification. The main features of the UART interface are:

- FIFO mode permanently selected for transmit and receive operations
- 2 pins for transmit and receive operations
- 2 flow control pins
- Interrupt triggers for low-power, high throughput operation
- High throughput (4 Mbps)

The UART interface operation includes:

- Uploading the firmware to the module
- Supporting data input/output operation for peripheral devices connected through a standard UART interface

Baud Rate				
1200	38400	460800	1500000	3000000
2400	57600	500000	1843200	3250000
4800	76800	921600	2000000	3692300
9600	115200	1000000	2100000	4000000
19200	230400	1382400	2764800	

**Table 8: Supported UART Baud rates**

## 2.4 PCM interface

The EMMY-W1 series modules support a Pulse Code Modulation (PCM) interface that provides:

- Master or slave mode
- PCM bit width size of 8 bits or 16 bits
- Up to 4 slots with configurable bit width and start positions
- Short frame and long frame synchronization

### 2.4.1 PCM interface specifications

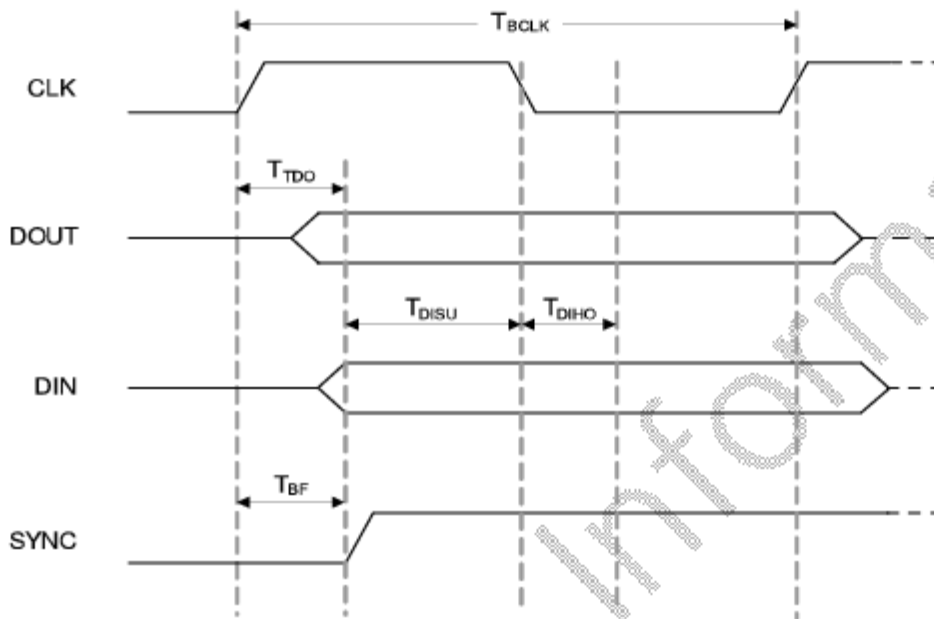
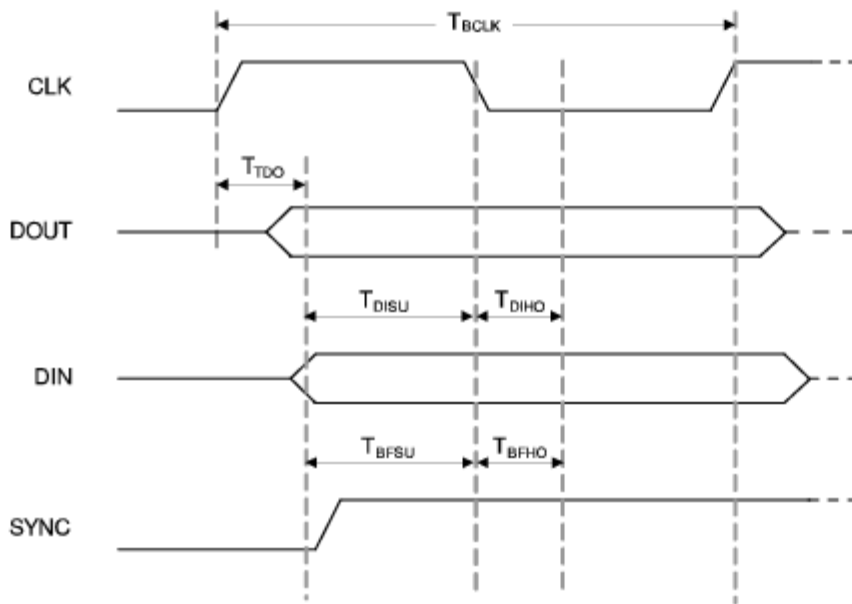

Figure 9: PCM timing specification – Master mode

Symbol	Parameter	Condition	Min.	Typ	Max.	Units
$f_{CLK}$	-	-	-	2/2.048	-	MHz
Duty Cycle <sub>CLK</sub>	-	-	0.4	0.5	0.6	-
$T_{CLK\_RMTA}$	-	-	-	3	-	ns
$T_{DO}$	-	-	-	-	15	ns
$T_{DISU}$	-	-	20	-	-	ns
$T_{DIHO}$	-	-	15	-	-	ns
$T_{BF}$	-	-	-	-	15	ns

Table 9: PCM timing specification – Master mode

**Figure 10: PCM timing specification – Slave mode**

Symbol	Parameter	Condition	Min.	Typ	Max.	Units
$F_{\text{CLK}}$	-	-	-	2/2.048	-	MHz
Duty Cycle <sub>CLK</sub>	-	-	0.4	0.5	0.6	-
$T_{\text{BCLK,HW}}^{\text{min}}$	-	-	-	3	-	ns
$T_{\text{DO}}$	-	-	-	-	30	ns
$T_{\text{DISU}}$	-	-	15	-	-	ns
$T_{\text{DIHO}}$	-	-	10	-	-	ns
$T_{\text{BFSU}}$	-	-	15	-	-	ns
$T_{\text{BFHO}}$	-	-	10	-	-	ns

**Table 10: PCM timing specification – Slave mode**

## 2.5 GPIO interface

The General-Purpose I/O (GPIO) interface is used to implement user defined input and output signals to and from the 88W8887 chip such as external interrupts and other user-defined I/Os. Main features of the GPIO interface include:

- User-defined GPIO (each I/O configured to either input or output)
- Each GPIO independently controlled
- Each I/O configurable to output bit from GPIO\_OUT

The general functions associated with each GPIO pin is shown in Table 11:



GPIO Function	GPIO Pin																	
	0	1	2	3	4	5	6	7	8	9	10	11	12	13	14	15	16	17
<b>General</b>																		
Input	X	X	X	X	X	X	X	X	X	X	X	X	X	X	X	X	X	X
Output	X	X	X	X	X	X	X	X	X	X	X	X	X	X	X	X	X	X
<b>LEDs</b>																		
LED output <sup>7</sup>	-	-	X	X	-	-	-	-	-	-	-	-	-	-	-	-	-	-
<b>Interrupts</b>																		
Input	X	X	X	X	X	X	X	X	X	X	X	X	X	X	X	X	X	X

**Table 11: GPIO Functions – GPIO [17:14], [12:0]**

 **GPIO\_12 is not available.**

Advance Information

<sup>7</sup> GPIO [2] is used for Wi-Fi activity while GPIO [3] is used for Bluetooth activity.

## 3 Pin Definition

### 3.1 Pin description

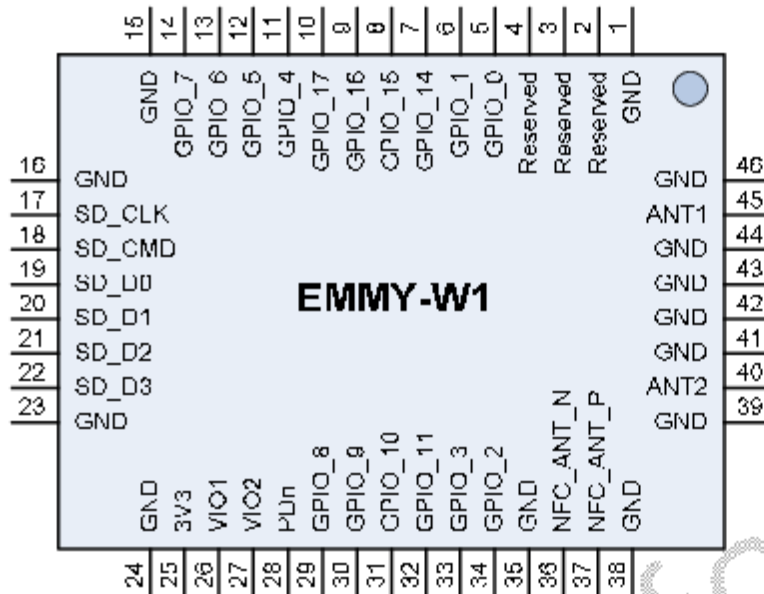

Figure 11: Pin assignment

No	Pin name	Pin type	Supply domain	Description
1	GND	Ground	-	Ground
2	NC	-	-	Reserved, do not connect
3	NC	-	-	Reserved, do not connect
4	NC	-	-	Reserved, do not connect
5	GPIO_0	I/O	VIO2	BT2HOST_WAKEUP (Output)
6	GPIO_1	I/O	VIO2	WL2HOST_WAKEUP (Output)
7	GPIO_14	I/O	VIO2	HOST2WL_WAKEUP (Input)
8	GPIO_15	I/O	VIO2	HOST2BT_WAKEUP (Input)
9	GPIO_16	I/O	VIO2	UART_LTE_SIN (Input)
10	GPIO_17	I/O	VIO2	UART_LTE_SOUT (Output)
11	GPIO_4	I/O	VIO2	PCM_DIN (Input)
12	GPIO_5	I/O	VIO2	PCM_DOUT (Output)
13	GPIO_6	I/O	VIO2	PCM_CLK (Input if slave, Output if master)
14	GPIO_7	I/O	VIO2	PCM_SYNC (Input if slave, Output if master)
15	GND	Ground	-	Ground
16	GND	Ground	-	Ground
17	SD_CLK	I	VIO1	SDIO Clock input
18	SD_CMD	I/O	VIO1	SDIO Command line
19	SD_D0	I/O	VIO1	SDIO Data line bit [0]
20	SD_D1	I/O	VIO1	SDIO Data line bit [1]
21	SD_D2	I/O	VIO1	SDIO Data line bit [2]
22	SD_D3	I/O	VIO1	SDIO Data line bit [3]

No	Pin name	Pin type	Supply domain	Description
23	GND	Ground	-	Ground
24	GND	Ground	-	Ground
25	3V3	Power	3.3V	3.3V Power supply (2.97 V - 3.63 V)
26	VIO1	Power	VIO1	VIO1 Power supply (1.62V - 1.98 V, 2.97 V - 3.63 V)
27	VIO2	Power	VIO2	VIO2 Power supply (1.62V - 1.98 V, 2.97 V - 3.63 V)
28	PDn	Input	-	Full power down(active low) <sup>a</sup>
29	GPIO_8	I/O	VIO2	UART_SOUT (Output)
30	GPIO_9	I/O	VIO2	UART_SIN (Input)
31	GPIO_10	I/O	VIO2	UART_CTSn (Input)
32	GPIO_11	I/O	VIO2	UART_RTSn (Output)
33	GPIO_3	I/O	3.3V	LED_OUT_BT (Output) - BT indicator, Configuration pin <sup>b</sup>
34	GPIO_2	I/O	3.3V	LED_OUT_WLAN (Output) - WLAN indicator, Configuration pin <sup>b</sup>
35	GND	Ground	-	Ground
36	NFC_ANT_N	I/O, RF	3.3V	NFC Coil Antenna, negative I/O pin
37	NFC_ANT_P	I/O, RF	3.3V	NFC Coil Antenna, positive I/O pin
38	GND	Ground	-	Ground
39	GND	Ground	-	Ground
40	ANT2	I/O, RF	-	Bluetooth antenna only in case of EMMY-W163 module. Not connected in case of EMMY-W161 or EMMY-W165 module <sup>c</sup>
41	GND	Ground	-	Ground
42	GND	Ground	-	Ground
43	GND	Ground	-	Ground
44	GND	Ground	-	Ground
45	ANT1	I/O, RF	-	Wi-Fi + Bluetooth antenna in case of single-antenna module. Wi-Fi antenna only in case of dual-antenna module <sup>d</sup>
46	GND	Ground	-	Ground
-	Exposed pin	Ground	-	Six Ground/Thermal exposed pins, connect to the ground

**Table 12: EMMY-W1 series pin description**

## 3.2 Reset configuration

The EMMY-W1 is reset to its default operating state under the following conditions:

- Power-on reset (POR) – Module receives power 3V3 supplies rise (triggers internal POR circuit)
- Software/Firmware reset
- External pin assertion (PDn) will generate POR.

<sup>a</sup> High input impedance pin for minimizing shutdown current consumption. The pin shall be driven by the host controller or/and connected via 51 k $\Omega$  (or less) pull-up resistor to the 3.3 V supply rail.

<sup>b</sup> Possible to use as an LED output depending on the firmware and driver version. In this case, the module pin acts as an open drain output and the whole LED circuitry must be supplied from 3.3 V power line. A LED current limiting resistor should be used; maximum sink current to the ground is 10 mA. These pins can also be used for host interface configuration. See Operation mode configuration section.

<sup>c</sup> Pin protected from the static electricity by internal DC feed to the ground.

## 4 Electrical specification

**⚠** Stressing the device above one or more of the ratings listed in the Absolute Maximum Rating section may cause permanent damage. These are stress ratings only. Operating the module at these or at any conditions other than those specified in the Operating conditions section (section 4.2) of the specification should be avoided. Exposure to Absolute Maximum Rating conditions for extended periods may affect device reliability.

**👉** Operating condition ranges define those limits within which the functionality of the device is guaranteed. Where application information is given, it is advisory only and does not form part of the specification.

### 4.1 Absolute maximum ratings

Symbol	Description	Min.	Typ	Max.	Units
3V3	Power supply voltage 3.3 V	-	3.3	4.0	V
VIO1	I/O supply voltage 1.8 V		1.8	2.2	V
	I/O supply voltage 3.3 V		3.3	4.0	V
VIO2	I/O supply voltage 1.8 V	-	1.8	2.2	V
	I/O supply voltage 3.3 V		3.3	4.0	V
T <sub>STORAGE</sub>	Storage temperature	-40		+85	°C

Table 13: Absolute maximum ratings

**⚠** The product is not protected against overvoltage or reversed voltages. If necessary, voltage spikes exceeding the power supply voltage specification given in table above must be limited to values within the specified boundaries by using appropriate protection devices.

### 4.2 Operating conditions

Symbol	Parameter	Min.	Typ	Max.	Units
3V3	Power supply voltage 3.3 V	2.97	3.3	3.63	V
VIO1	I/O supply voltage 1.8V/3.3 V	1.62	1.8	1.98	V
		2.97	3.3	3.63	V
VIO2	I/O supply voltage 1.8V/3.3 V	1.62	1.8	1.98	V
		2.97	3.3	3.63	V
VDD_NFC	NFC antenna input voltage (pins NFC_ANT_P/N)	-	-	3.6	V
IANT_NFC	NFC antenna peak input current (pins NFC_ANT_P/N))	-	-	400	mA
T <sub>a</sub>	Ambient operating temperature	-40	-	+85	°C
Ripple Noise	Peak-to-peak voltage ripple on 3V3, VIO1 or VIO2 supply line. The values have been determined in a frequency range from 10 KHz to > 2 MHz [3].	20	-		mV

Table 14: Operating conditions

Parameter	Min.	Typ	Max.	Units
Storage temperature	-40		+85	°C
Operation temperature	-40		+85	°C

Table 15: Temperature range

### 4.3 Digital pin ratings

Symbol	Parameter	Min.	Max.	Units
V <sub>ih</sub>	Input high voltage	0.7 *V <sub>IO</sub>	V <sub>IO</sub> +0.4	V
V <sub>il</sub>	Input low voltage	-0.4	0.3 *V <sub>IO</sub>	V
V <sub>ihys</sub>	Input hysteresis	100	-	mV
V <sub>oh</sub>	Output high voltage	V <sub>IO</sub> -0.4	-	V
V <sub>oil</sub>	Output low voltage	-	0.4	V

Table 16: Digital pin ratings for VIO1 and VIO2 supply domains

### 4.4 Wi-Fi power consumption

Operation mode: 2.4 GHz Wi-Fi TX/RX with BT and NFC in Deep Sleep mode	Average current, mA <sup>11</sup>	Peak current, mA <sup>12</sup>
RX Idle Default	52	64
RX 11 Mbps	50	62
TX 11 Mbps (Normal power mode, 18 dBm)	290	420
TX 11 Mbps (Low power mode, 10 dBm)	184	
RX 54 Mbps	54	68
TX 54 Mbps (15 dBm)	260	320
TX 54 Mbps (8 dBm)	170	
RX 11n MCS7 (HT20)	65	
TX 11n MCS7 (HT20, 15 dBm)	260	
TX 11n MCS7 (HT20, 8 dBm)	174	

Operation mode: 5 GHz Wi-Fi TX/RX with BT and NFC in Deep Sleep mode	Average current, mA <sup>11</sup>	Peak current, mA <sup>12</sup>
RX 54 Mbps	67	75
TX 54 Mbps (12 dBm)	280	320
TX 54 Mbps (8 dBm)	196	
RX MCS7 (HT20)	78	
TX MC 57 (HT20, 12 dBm)	282	
TX MC 57 (HT20, 8 dBm)	202	
RX MCS7 (HT40)	89	
TX MC 57 (HT40, 10 dBm)	270	
TX MC 57 (HT40, 8 dBm)	214	
RX MCS7 (VHT80)	112	
TX MC 57 (VHT80, 11 dBm)	360	
RX MCS8 (VHT20)	82	
TX MC 58 (VHT20, 11 dBm)	265	
RX MCS8 (VHT40)	105	
TX MC 58 (VHT40, 10 dBm)	265	
RX MCS8 (VHT80)	114	
TX MC 58 (VHT80, 8 dBm)	356	
RX MCS9 (VHT40)	104	
TX MC 59 (VHT40, 10 dBm)	263	
RX MCS9 (VHT80)	120	
TX MC 59 (VHT80, 8 dBm)	348	

<sup>11</sup> Supply 3.3V. Wi-Fi client mode. Numbers obtained from IPERF UDP traffic.

<sup>12</sup> Maximum peak current for the worst supply conditions

Operation mode: Power save modes	Average current, mA
Power Down	0.03
WiFi and BT both in DeepSleep	0.13
WiFi DTIM 1 and BT DeepSleep	1.14
WiFi DTIM 3 and BT DeepSleep	0.47
WiFi DTIM 5 and BT DeepSleep	0.34

**Table 17: Wi-Fi power consumption**

## 4.5 Bluetooth power consumption

Bluetooth mode with Wi-Fi and NFC in deep sleep mode TX @ 0dBm	Average current, mA <sup>1)</sup>
Deep Sleep Mode	0.125
BT idle (Sleep Mode)	4.23
Power Down	0.03
SCO HV3 Peak TX	18.75
SCO HV3 Peak RX	16.50
HV3 SCO mode ACL sniff 0x800	7.57
eSCO link, Master (2-EV3), ACL sniff 0x800	6.57
eSCO link, Master (EV3), ACL sniff 0x800	7.69
ACL (data pump) DH1	11.60
ACL (data pump) DH3	14.60
ACL (data pump) DH5	16.40
ACL Link, master sniff mode, interval=1.28s (800)	0.186
ACL Link, master sniff mode, interval=500ms (320)	0.278
SCO HV3 Average TX @ 4 dBm (external antenna)	7.83
SCO HV3 Average RX @ 4 dBm (external antenna)	22.00
Interlaced scan (= P&I scan)	0.372
Page & Inquiry scan	0.372
Page Scan	0.257
Inquiry Scan	0.257
LE Advertise @ 1.28s interval	0.150
Peak LE TX	18.00
Peak LE RX	16.00
LE Link (interval=400=1.28s)	0.154
LE Link (interval=320=1.00s)	0.155
LE Scan (interval=800=1.28s)	0.231
LE Scan (interval=640=1.00s)	0.262

**Table 18: Bluetooth power consumption**

## 4.6 NFC power consumption

Operation Mode	Average current, mA	3V3
TAG Type 1		90
TAG Type 2		95
TAG Type 3		85
TAG Type 4A		100

**Table 19: NFC power consumption**
<sup>1)</sup> Supply 3.3V, Average consumption current if not specified otherwise.

## 4.7 Radio specifications

### 4.7.1 Wi-Fi

The EMMY-W1 series modules support Wi-Fi standards IEEE 802.11a/b/g/n/ac in 2.4 GHz and 5 GHz radio bands. In the 2.4 GHz band, the EMMY-W1 supports 802.11b/g/n while in 5 GHz band, it supports 802.11a/n/ac.

Parameter	Operation Mode		Specification		
RF Frequency range	802.11b/g/n		2.400 – 2.500 GHz		
	802.11a/n/ac		5.150 – 5.850 GHz		
Modulation	802.11b		CCK and DSSS		
	802.11a/g/n/ac		OFDM		
Supported data rates	802.11b		1, 2, 5.5, 11 Mbps		
	802.11a/g		6, 9, 12, 18, 24, 36, 48, 54 Mbps		
	802.11n		MCS0 – MCS7 (150 Mbps)		
	802.11ac		MCS0 – MCS9 (433 Mbps)		
Supported channel bandwidth	802.11ac		20, 40, 80 MHz		
Supported guard interval (GI)	802.11n		400, 800 ns		
	802.11ac		Short guard interval supported		
Maximum transmit power	802.11b		18 dBm ± 1.5 dB		
	802.11a/g/n/ac		16 dBm ± 1.5 dB		
Receiver sensitivity	2.4 GHz	802.11b	1 Mbps	-98 dBm ± 1 dB	
			11 Mbps	-89 dBm ± 1 dB	
		802.11g	6 Mbps	-91 dBm ± 1 dB	
			54 Mbps	-74 dBm ± 1 dB	
		802.11n	20 MHz	MCS0	-91 dBm ± 1 dB
				MCS7	-73 dBm ± 1 dB
	40 MHz		MCS0	-89 dBm ± 1 dB	
			MCS7	-71 dBm ± 1 dB	
	5 GHz	802.11a	6 Mbps	-91 dBm ± 1 dB	
			54 Mbps	-74 dBm ± 1 dB	
		802.11n	20 MHz	MCS0	-90 dBm ± 1 dB
				MCS7	-72 dBm ± 1 dB
40 MHz			MCS0	-88 dBm ± 1 dB	
			MCS9	-63 dBm ± 1 dB	
802.11ac	80 MHz	MCS0	-85 dBm ± 1 dB		
		MCS9	-60 dBm ± 1 dB		

Table 20: Wi-Fi radio specifications

Channel	Frequency, GHz	Channel	Frequency, GHz	Channel	Frequency, GHz
1	2.412	6	2.437	11	2.462
2	2.417	7	2.442	12	2.467
3	2.422	8	2.447	13	2.472
4	2.427	9	2.452		
5	2.432	10	2.457		

Table 21: 2.4 GHz Band Supported Channels, 20 MHz bandwidth

Channel	Frequency, GHz	Channel	Frequency, GHz	Channel	Frequency, GHz
1 - 5	2.422	4 - 8	2.437	7 - 11	2.452
2 - 6	2.427	5 - 9	2.442		
3 - 7	2.432	6 - 10	2.447		

Table 22: 2.4 GHz band supported channels, 40 MHz bandwidth

Channel	Frequency, GHz	Channel	Frequency, GHz	Channel	Frequency, GHz
36	5.180	100	5.500	144	5.720
40	5.200	104	5.520	149	5.745
44	5.220	108	5.540	153	5.765
48	5.240	112	5.560	157	5.785
52	5.260	116	5.580	161	5.805
56	5.280	132	5.660	165	5.825
60	5.300	136	5.680		
64	5.320	140	5.700		

**Table 23: 5 GHz band supported channels, 20 MHz bandwidth**

Channel	Frequency, GHz	Channel	Frequency, GHz	Channel	Frequency, GHz
36 - 40	5.190	100 - 104	5.510	149 - 153	5.755
44 - 48	5.230	108 - 112	5.550	157 - 161	5.795
52 - 56	5.270	132 - 136	5.670		
60 - 64	5.310	140 - 144	5.710		

**Table 24: 5 GHz band supported channels, 40 MHz bandwidth**

Channel	Frequency, GHz	Channel	Frequency, GHz	Channel	Frequency, GHz
42	5.210	106	5.530	155	5.775
58	5.290	138	5.690		

**Table 25: 5 GHz band supported channels, 80 MHz bandwidth**

 The module is certified to operate as both client and master on channels 1 - 13 (2412 - 2462 MHz), and channel 36 - 48 (5180 - 5240 MHz). On the following channels it is certified to operate as a client only 52 - 64 (5260 - 5320 MHz), 100 - 116 (5500 - 5580 MHz), 132 - 140 (5660 - 5700 MHz) and 149 - 165 (5745 - 5825 MHz). When the module is set to operate on channels 52 - 64, 100 - 116, 132 - 140 and 149 - 165 it is restricted to only operate using passive scan.

 The module is certified to operate with the power tables shown in Table 26 for operation in the 2.4 GHz band and from Table 27 to Table 29 for operation in the 5 GHz band. The specified values are the maximum permitted output power settings.



Channel	Modulation	Channel bandwidth	Data rates	Maximum power setting
1-11	CCK and DSSS		1, 2, 5.5, 11 Mbps	18 dBm
12	CCK and DSSS		1, 2, 5.5, 11 Mbps	15 dBm
13	CCK and DSSS		1, 2, 5.5, 11 Mbps	13 dBm (EMMY-W161), 12 dBm (EMMY-W163)
1	OFDM	20 MHz	6, 9, 12, 18, 24, 36 Mbps	13 dBm
2-9	OFDM	20 MHz	6, 9, 12, 18, 24, 36 Mbps	16 dBm
10	OFDM	20 MHz	6, 9, 12, 18, 24, 36 Mbps	15 dBm
11	OFDM	20 MHz	6, 9, 12, 18, 24, 36 Mbps	13 dBm
12	OFDM	20 MHz	6, 9, 12, 18, 24, 36 Mbps	10 dBm
13	OFDM	20 MHz	6, 9, 12, 18, 24, 36 Mbps	9 dBm (EMMY-W161), 8 dBm (EMMY-W163)
1-11	OFDM	20 MHz	48, 54 Mbps	13 dBm
12-13	OFDM	20 MHz	48, 54 Mbps	9 dBm
1	OFDM	20 MHz	HT20 MCS0-MCS4	13 dBm
2	OFDM	20 MHz	HT20 MCS0-MCS4	15 dBm
3-10	OFDM	20 MHz	HT20 MCS0-MCS4	16 dBm
11	OFDM	20 MHz	HT20 MCS0-MCS4	12 dBm
12-13	OFDM	20 MHz	HT20 MCS0-MCS4	9 dBm
1-10	OFDM	20 MHz	HT20 MCS5-MCS7	13 dBm
11	OFDM	20 MHz	HT20 MCS5-MCS7	12 dBm
12-13	OFDM	20 MHz	HT20 MCS5-MCS7	9 dBm (EMMY-W161), 8 dBm (EMMY-W163)
3 (2.422 GHz), 4 (2.427 GHz)	OFDM	40 MHz	HT40 MCS0-MCS4	11 dBm (EMMY-W161), 10 dBm (EMMY-W163)
5 (2.432 GHz)	OFDM	40 MHz	HT40 MCS0-MCS4	13 dBm
6 (2.437 GHz), 7 (2.442 GHz)	OFDM	40 MHz	HT40 MCS0-MCS4	14 dBm
8 (2.447 GHz)	OFDM	40 MHz	HT40 MCS0-MCS4	13 dBm
9 (2.452 GHz)	OFDM	40 MHz	HT40 MCS0-MCS4	10 dBm
3 (2.422 GHz), 4 (2.427 GHz)	OFDM	40 MHz	HT40 MCS5-MCS7	11 dBm
5 (2.432 GHz), 6 (2.437 GHz), 7 (2.442 GHz), 8 (2.447 GHz)	OFDM	40 MHz	HT40 MCS5-MCS7	13 dBm
9 (2.452 GHz)	OFDM	40 MHz	HT40 MCS5-MCS7	11 dBm

**Table 26: WLAN power table for operation in the 2.4 GHz band**

Channel	Modulation	Channel bandwidth	Data rates	Maximum power setting
36, 64	OFDM	20 MHz	6, 9, 12, 18, 24, 36 Mbps	13 dBm
40, 44, 48, 52, 56, 60	OFDM	20 MHz	6, 9, 12, 18, 24, 36 Mbps	16 dBm
36, 40, 44, 48, 52, 56, 60, 64	OFDM	20 MHz	48, 54 Mbps	13 dBm
36, 64	OFDM	20 MHz	HT20 MCS0-MCS4	13 dBm
40, 44, 48, 52, 56, 60	OFDM	20 MHz	HT20 MCS0-MCS4	16 dBm
36, 40, 44, 48, 52, 56, 60, 64	OFDM	20 MHz	HT20 MCS5-MCS7	13 dBm
36, 64	OFDM	20 MHz	VHT20 MCS0-MCS4	13 dBm
40, 44, 48, 52, 56, 60	OFDM	20 MHz	VHT20 MCS0-MCS4	16 dBm
36, 40, 44, 48, 52, 56, 60, 64	OFDM	20 MHz	VHT20 MCS5-MCS8	13 dBm
38 (5.190 GHz), 62 (5.310 GHz)	OFDM	40 MHz	HT40 MCS0-MCS4	12 dBm
46 (5.230 GHz), 54 (5.270 GHz)	OFDM	40 MHz	HT40 MCS0-MCS4	16 dBm
38 (5.190 GHz), 46 (5.230 GHz), 54 (5.270 GHz), 62 (5.310 GHz)	OFDM	40 MHz	HT40 MCS5-MCS7	12 dBm (ELA-W161), 11 dBm (ELA-W163)
38 (5.190 GHz), 62 (5.310 GHz)	OFDM	40 MHz	VHT40 MCS0-MCS4	12 dBm
46 (5.230 GHz), 54 (5.270 GHz)	OFDM	40 MHz	VHT40 MCS0-MCS4	16 dBm
38 (5.190 GHz), 46 (5.230 GHz), 54 (5.270 GHz), 62 (5.310 GHz)	OFDM	40 MHz	VHT40 MCS5-MCS7	12 dBm
38 (5.190 GHz), 46 (5.230 GHz), 54 (5.270 GHz), 62 (5.310 GHz)	OFDM	40 MHz	VHT40 MCS8-MCS9	10 dBm
42 (5.210 GHz), 58 (5.290 GHz)	OFDM	80 MHz	VHT80 MCS0-MCS9	8 dBm

**Table 27: WLAN power table for operation in the 5 GHz U-NII-1 and U-NII-2A bands**

Channel	Modulation	Channel bandwidth	Data rates	Maximum power setting
100, 140	OFDM	20 MHz	6, 9, 12, 18, 24, 36 Mbps	13 dBm
104-136 (exc. 120-128)	OFDM	20 MHz	6, 9, 12, 18, 24, 36 Mbps	16 dBm
100-140 (exc. 120-128)	OFDM	20 MHz	48, 54 Mbps	13 dBm
100, 140	OFDM	20 MHz	HT20 MCS0-MCS4	13 dBm
104-136 (exc. 120-128)	OFDM	20 MHz	HT20 MCS0-MCS4	16 dBm
100-140 (exc. 120-128)	OFDM	20 MHz	HT20 MCS5-MCS7	13 dBm
100	OFDM	20 MHz	VHT20 MCS0-MCS4	13 dBm
104-144 (exc. 120-128)	OFDM	20 MHz	VHT20 MCS0-MCS4	16 dBm
100-144 (exc. 120-128)	OFDM	20 MHz	VHT20 MCS5-MCS8	13 dBm
102 (5.510 GHz), 134 (5.670 GHz)	OFDM	40 MHz	HT40 MCS0-MCS4	12 dBm
110 (5.550 GHz)	OFDM	40 MHz	HT40 MCS0-MCS4	16 dBm
102 (5.510 GHz), 110 (5.550 GHz), 134 (5.670 GHz)	OFDM	40 MHz	HT40 MCS5-MCS7	12 dBm
102 (5.510 GHz)	OFDM	40 MHz	VHT40 MCS0-MCS4	12 dBm
110 (5.550 GHz), 134 (5.670 GHz)	OFDM	40 MHz	VHT40 MCS0-MCS4	16 dBm

Channel	Modulation	Channel bandwidth	Data rates	Maximum power setting
142 (5.710 GHz)				
102 (5.510 GHz), 110 (5.550 GHz), 134 (5.670 GHz), 142 (5.710 GHz)	OFDM	40 MHz	VHT40 MCS5-MCS7	12 dBm
102 (5.510 GHz), 110 (5.550 GHz), 134 (5.670 GHz), 142 (5.710 GHz)	OFDM	40 MHz	VHT40 MCS8-MCS9	10 dBm
106 (5.530 GHz)	OFDM	80 MHz	VHT80 MCS0-MCS9	8 dBm
138 (5.690 GHz)	OFDM	80 MHz	VHT80 MCS0-MCS2	16 dBm
138 (5.690 GHz)	OFDM	80 MHz	VHT80 MCS3-MCS4	13 dBm
138 (5.690 GHz)	OFDM	80 MHz	VHT80 MCS5-MCS7	10 dBm
138 (5.690 GHz)	OFDM	80 MHz	VHT80 MCS8-MCS9	8 dBm

**Table 28: WLAN power table for operation in the 5 GHz U-NII-2e band**

Channel	Modulation	Channel bandwidth	Data rates	Maximum power setting
149, 165	OFDM	20 MHz	6, 9, 12, 18, 24, 36 Mbps	14 dBm
153, 157, 161	OFDM	20 MHz	6, 9, 12, 18, 24, 36 Mbps	16 dBm
149-165	OFDM	20 MHz	48, 54 Mbps	13 dBm
149, 165	OFDM	20 MHz	HT20 MCS0-MCS4	13 dBm
153, 157, 161	OFDM	20 MHz	HT20 MCS0-MCS4	16 dBm
149-165	OFDM	20 MHz	HT20 MCS5-MCS7	13 dBm
149	OFDM	20 MHz	VHT20 MCS0-MCS4	13 dBm
153, 157, 161, 165	OFDM	20 MHz	VHT20 MCS0-MCS4	16 dBm
149-165	OFDM	20 MHz	VHT20 MCS5-MCS8	13 dBm
151 (5.755 GHz)	OFDM	40 MHz	HT40 MCS0-MCS4	12 dBm
159 (5.795 GHz)	OFDM	40 MHz	HT40 MCS0-MCS4	16 dBm
151 (5.755 GHz), 159 (5.795 GHz)	OFDM	40 MHz	HT40 MCS5-MCS7	12 dBm
151 (5.755 GHz), 159 (5.795 GHz)	OFDM	40 MHz	VHT40 MCS0-MCS9	12 dBm
155 (5.775 GHz)	OFDM	80 MHz	VHT80 MCS0-MCS9	8 dBm

**Table 29: WLAN power table for operation in the 5 GHz U-NII-3 band**

## 4.7.2 Bluetooth

Parameter	Specifications
RF Frequency Range	2.400 – 2.4835 GHz
Supported Modes	Bluetooth v4.2 (including Bluetooth Low Energy and Classic Bluetooth with BR and EDR)
Number of channels	79
Modulation	1 Mbps: GFSK (BR) 2 Mbps: $\pi/4$ DQPSK (EDR) 3 Mbps: 8DQPSK (EDR)
Transmit Power	Class 2, Class 1, BR: 10 dBm $\pm$ 2 dB, EDR: 8 dBm $\pm$ 2 dB <sup>14</sup>
Receiver Sensitivity	-85 dBm

**Table 30: Bluetooth radio specifications**

## 4.7.3 LTE co-existence

Specific influence of BAW filters on the following RF parameters:

- Wi-Fi output power
- Wi-Fi sensitivity
- Bluetooth output power
- Bluetooth sensitivity

Characterization of LTE co-existence:

- Maximum tolerated input power from LTE interferer
- Rejection in LTE bands
- Wi-Fi and Bluetooth desensitization in presence of LTE transmission in adjacent bands for given antenna isolation
- BAW decrease influence to LTE as well



The BAW-Filter is included only in the EMMY-W161 module variant.

## 4.7.4 Near field communication

### 4.7.4.1 Card emulator specifications

Parameter	Condition	Minimum	Type	Maximum	Units
AC characteristics					
Vsens <sub>NCC</sub>	Input carrier detection level, full-power mode, peak sinus differential voltage on NFC_ANT_P/N pin	-	300	-	mV <sub>peak</sub>
MOD <sub>NCC</sub>	Input ASK modulation index <sup>15</sup>	8	-	100	%
DR <sub>NCC</sub>	Input data rate (coding depending on standard: Manchester, Modified, Miller, or NRZ)	106	-	848	Kbps

**Table 31: NFC card emulator**



For typical recommended operating conditions unless otherwise specified.

### 4.7.4.2 Reader/Writer specifications

Parameter	Condition	Minimum	Type	Maximum	Units
DC characteristics					
VCM <sub>Tx_PA</sub>	Power amplifier output common mode level	-	VDDTX/2	-	V
AC characteristics					

<sup>14</sup> For regulatory reasons in Europe only class 2 operations are permitted.

<sup>15</sup> As defined in ISO/IEC 14443-2, for example, [a-b]/[a+b] where a and b are the peak and minimum signal amplitude respectively.

Parameter	Condition	Minimum	Type	Maximum	Units
$F_{TXCARR}$	Output carrier frequency	13.553	13.56	13.567	MHz
$R_{OUT\_ANT}$	Power amplifier output impedance	-	50	-	$\Omega$
$MOD_{ICD}$	Output ASK modulation index 15	8	-	100	%

**Table 32: NFC Reader/Writer specifications**

For typical recommended operating conditions unless otherwise specified.

## 5 Host drivers and firmware

### 5.1 General principle

The EMMY-W1 series module does not contain any persistent software. A firmware binary will be downloaded by the host operating system driver on system start-up.

### 5.2 Supported operating systems

#### 5.2.1 Linux

Linux device drivers are available from u-blox. Once you sign the Limited Use License Agreement (LULA) with u-blox, a driver package will be available. This package includes:

- Dedicated Kernel driver, to bind the Wi-Fi, Bluetooth and NFC block to the kernel. The sources of those drivers will be provided.
- A dedicated firmware image, which will be uploaded during initialization.
- Various configuration tools
- Laboratory and manufacturing tools

For a detailed description of the driver packages, refer to *EMMY-W1 series System Integration Manual* [3].



## 7 Qualification and approvals

### 7.1 Approvals<sup>16</sup>



Products marked with this lead-free symbol on the product label comply with the "Directive 2002/95/EC of the European Parliament and the Council on the Restriction of Use of certain Hazardous Substances in Electrical and Electronic Equipment" (RoHS).

EMMY-W1 series Wi-Fi modules are RoHS compliant.

#### 7.1.1 European Union regulatory compliance

The EMMY-W1 series module complies with the regulatory standards

##### Effective use of spectrum:

EN 300 328 V 1.8.1

EN 301 893 V 1.7.1

##### EMC:

EN 301 489-1/-17

##### Health and safety:

EN 60950-1:2006 + A11:2009

EN 62311 (WLAN)

EN 62479 (BT)

We declare that the human exposure of these modules is below the SAR limits specified in the EU recommendations 1999/519/EC.

##### 7.1.1.1 Equipment classes

A multi-radio module is classified as class-1 or class-2 radio equipment depending on the frequency band in which it can operate. This equipment class is inherited by the end-product that integrates the module, thus it must be marked accordingly.

**Class-1** radio equipment can be placed on the market and put into service without restrictions. (Article 1 of Commission Decision 2000/299/EC of April 6 2000)

This multi-radio module is defined as class-1 radio equipment when it is restricted to operate in the following frequency bands:

- Bluetooth , ISM band 2400 – 2483.5 MHz
- WLAN, ISM band 2400 – 2483.5 MHz
- WLAN, U-NII band-2e 5470 – 5725 MHz

**Class-2** radio equipment includes restrictions applied by Member States as indicated in Article 1(2) of the Commission Decision. This class uses the "Alert Sign" as an equipment class identifier.



Figure 13: Alert sign to identify equipment Class-2

<sup>16</sup> These approvals are pending.



If an end product allows the multiradio module to operate in the 5150-5350 MHz band (WLAN channel: 36-64), it is defined as class-2 radio equipment and must be marked accordingly. Class-2 radio equipment must have the "alert" sign affixed on the equipment, packaging and printed in the user manual.

The EMMY-W1 multiradio module uses harmonized frequency bands thus it is comprised by subclass H01 of class 2 equipment, for which notification in accordance with article 6(4) of the R&TTE directive is not necessary.

A definition of subclasses of Class 2 equipment can be found in the following link:

[http://ec.europa.eu/enterprise/sectors/rtte/files/rtte-subclass2\\_en.pdf](http://ec.europa.eu/enterprise/sectors/rtte/files/rtte-subclass2_en.pdf)

The table below shows the restrictions when operating WLAN at different bands within the European countries

Band	Channel number	Channel frequency [MHz]	Indoor use allowed	Outdoor use allowed	Radio Equipment Class
ISM	1 – 11	2412 – 2462	Yes	Yes	1
U-NII 1	36 – 48	5180 – 5240	Yes	No	2
U-NII 2	52 – 64	5260 – 5320	Yes	No	2
U-NII 2e	100 – 140	5500 – 5700	Yes	Yes	1

**Table 33. Operating restrictions and radio equipment classification of EMMY-W1 series**



**Guidance on how the end product is marked in accordance with the R&TTE directive can be found in the following links:**

[http://ec.europa.eu/enterprise/sectors/rtte/documents/index\\_en.htm](http://ec.europa.eu/enterprise/sectors/rtte/documents/index_en.htm) - h2-5

[http://ec.europa.eu/enterprise/sectors/rtte/documents/guidance/index\\_en.htm](http://ec.europa.eu/enterprise/sectors/rtte/documents/guidance/index_en.htm)

**A direct link to the quick guide to the marking requirements can be found here:**

[http://ec.europa.eu/enterprise/sectors/rtte/files/guidance/guidance\\_en.pdf](http://ec.europa.eu/enterprise/sectors/rtte/files/guidance/guidance_en.pdf)

**IMPORTANT: The "CE" marking must be affixed to a visible location on the OEM product in which this module is installed and has to be labeled in accordance to R&TTE Directive 1999/5/EC.**

## 7.1.2 FCC compliance

The **EMMY-W1** series module complies with Part 15 of the FCC Rules. Operation is subject to the following two conditions:

1. This device may not cause harmful interference, and
2. This device must accept any interference received, including interference that may cause undesired operation

Non authorized modification could void authority to use this equipment. The internal / external antenna(s) used for this module must provide a separation distance of at least 20 cm from all persons and must not be co-located or operating in conjunction with any other antenna or transmitter.

In accordance with 47 CFR § 15.19, the end product into which this module is integrated shall bear the following statement in a conspicuous location on the device:

This device complies with Part 15 of the FCC Rules. Operation is subject to the following two conditions:

1. This device may not cause harmful interference, and
2. This device must accept any interference received, including interference that may cause undesired operation

When the end-product is so small or for such use that it is not practical to place the above statement on it, the information shall be placed in a prominent location in the instruction manual or pamphlet supplied to the user or on the container in which the device is marketed. However, the FCC ID label must be displayed on the device.

If the end-product will be installed in locations where the end-user is not able to see the FCC ID and/or this statement, the FCC ID and the statement shall also be included in the end-product manual.



The outside of final products containing the EMMY-W1 module must display in a user accessible area a label referring to the enclosed module. This exterior label can use wording such as the following: "Contains Transmitter Module FCC ID: (XYZ)(UPN)" or "Contains FCC ID: (XYZ)(UPN)", where (XYZ) represents the FCC "Grantee Code" and (UPN) is the Unique Product Number decided by the grant owner<sup>17</sup>.

### 7.1.3 IC compliance

The EMMY-W1 series module complies with Industry Canada license-exempt RSSs. Operation is subject to the following two conditions:

- (1) This device may not cause interference, and
- (2) This device must accept any interference, including interference that may cause undesired operation of the device.



Any notification to the end user of installation or removal instructions about the integrated radio module is NOT allowed. Unauthorized modification could void authority to use this equipment.

This equipment complies with IC RSS-102 radiation exposure limits set forth for an uncontrolled environment. This equipment should be installed and operated with minimum distance 20 cm between the radiator and your body.

This radio transmitter IC: 8595A-EMMYW161, IC: 8595A-EMMYW163 and IC: 8595A-EMMYW165 has been approved by Industry Canada to operate with the antenna types listed below with the maximum permissible gain indicated. Antenna types not included in this list, having a gain greater than the maximum gain indicated for that type, are strictly prohibited for use with this device.



Operation in the band 5150–5250 MHz is only for indoor use to reduce the potential for harmful interference to co-channel mobile satellite systems;



Operation in the 5600-5650 MHz band is not allowed in Canada. High-power radars are allocated as primary users (i.e. priority users) of the bands 5250-5350 MHz and 5650-5850 MHz and that these radars could cause interference and/or damage to LE-LAN devices.

The Industry Canada certification label of a module shall be clearly visible at all times when installed in the host device; otherwise, the host device must be labeled to display the Industry Canada certification number for the module, preceded by the words "Contains transmitter module", or the word "Contains", or similar wording expressing the same meaning, as follows: "Contains transmitter module IC: (CN)-(UPN)", where (CN) is the Company Number registered at Industry Canada and (UPN) is the Unique Product Number decided by the grant owner.

Le présent appareil est conforme aux CNR d'Industrie Canada applicables aux appareils radio exempts de licence. L'exploitation est autorisée aux deux conditions suivantes:



- (1) l'appareil ne doit pas produire de brouillage, et
- (2) l'utilisateur de l'appareil doit accepter tout brouillage radioélectrique subi, même si le brouillage est susceptible d'en compromettre le fonctionnement.

Cet équipement est conforme aux limites d'exposition de rayonnement d'IC RSS-102 déterminées pour un environnement non contrôlé. Cet équipement devrait être installé et actionné avec la distance minimum 20 cm entre le radiateur et votre corps.

Cet émetteur radio, IC: 8595A-EMMYW161, IC: 8595A-EMMYW163 et IC: 8595A-EMMYW165 été approuvé par Industry Canada pour fonctionner avec les types d'antenne énumérés ci-dessous avec le gain maximum

<sup>17</sup> The FCC and IC IDs for the EMMY-W1 series module variants are shown in Table 37. Select the applicable ID.

autorisé et l'impédance nécessaire pour chaque type d'antenne indiqué. Les types d'antenne ne figurant pas dans cette liste et ayant un gain supérieur au gain maximum indiqué pour ce type-là sont strictement interdits d'utilisation avec cet appareil.

-  Le dispositif de fonctionnement dans la bande 5 150-5250 MHz est réservé à une utilisation en intérieur pour réduire le risque d'interférences nuisibles à la co-canal systèmes mobiles par satellite
-  Opération dans la bande 5600-5650 MHz n'est pas autorisée au Canada. Haute puissance radars sont désignés comme utilisateurs principaux (c.-à-d. utilisateurs prioritaires) des bandes 5250-5350 MHz et 5650-5850 MHz et que ces radars pourraient causer des interférences et / ou des dommages à dispositifs LAN-EL.

L'étiquette d'homologation d'Industrie Canada d'un module donné doit être posée sur l'appareil hôte à un endroit bien en vue en tout temps. En l'absence d'étiquette, l'appareil hôte doit porter une étiquette sur laquelle figure le numéro d'homologation du module d'Industrie Canada, précédé des mots « Contient un module d'émission », ou du mot « Contient », ou d'une formulation similaire allant dans le même sens et qui va comme suit : « Contient le module d'émission IC: (CN)-(UPN) », où (CN) représente le numéro de compagnie, attribué par Industrie Canada et (UPN) représente le numéro de produit unique attribué par le requérant.

-  **The approval of the variant EMMY-W165 with the IC: 8595A-EMMYW165 is still in progress and expected to be finished soon.**

The internal / external antenna(s) used for this module must provide a separation distance of at least 20 cm from all persons and must not be co-located or operating in conjunction with any other antenna or transmitter. See Table 34 for list of approved antennas.

-  The approval type for all the EMMY-W1 series variants is a limited modular approval. Due to Industry Canada Modular Approval Requirements (Source: RSP-100 Issue 10), any application which includes the module must be approved by the module manufacturer (u-blox). The application manufacturer must provide design data for the review procedure.

## 7.2 Approved antennas

For Bluetooth and Wi-Fi operation in the 2.4 GHz band and Wi-Fi operation in the 5 GHz band, the module has been tested and approved for use with the antenna listed in Table 34.

Manufacturer	Part Number	Antenna type	Peak gain [dBi]	
			2.4 GHz band	5 GHz band
Antenova	A10194	SMD chip antenna 10x10x0.9 [mm] [4]	1.8	4.1
Linx	ANT-DB1-RAF-RPS	Dual-band dipole antenna [5]	2.5	4.6
Taoglas	GW.40.2153	Dual-band dipole antenna [6]	3.74	2.5
Taoglas	GW.59.3153	Dual-band dipole antenna [7]	2.37	2.93
Walsin	RFDPA870900SBLB8G1	Dual-band dipole antenna [8]	2	3
Linx	ANT-2.4-CW-RCT-RP	Single-band dipole antenna [9]	2.2	N/A
Delock	88395	Dual-band dipole antenna [10]	1.5	2.1

**Table 34: List of approved dual-band antennas**

The module can be integrated with other antennas which the OEM installer must authorize with respective regulatory agencies and after approval of the module manufacturer.

### 7.2.1 Bluetooth antenna

The following antennas are designated for Bluetooth transmission on EMMY-W163:

Manufacturer	Part Number	Antenna type	Peak gain [dBi]
			2.4 GHz band
Johanson Technology	2450AT45A100	SMD chip antenna 10x10x0.9 [mm] [11]	2.2
Taoglas	GW.26.0151	Single-band monopole antenna [12]	0.0
Urx	ANT-2.4-CW-RH	Single-band monopole antenna [13]	-0.9

**Table 35: List of approved single-band antennas**

### 7.2.2 NFC antenna

The following antennas are designated to be used for Near Field Communication (NFC) on EMMY-W161, EMMY-W163 and EMMY-W165:

Manufacturer	Part Number	Antenna type
u-blox	EMMY_NFC_ANT	External PCB antenna with connector

**Table 36: List of approved NFC antenna**

## 7.3 FCC and IC IDs (planned)

Product name	FCC ID	IC ID
EMMY-W161	XPYEMMYW161	8595A-EMMYW161
EMMY-W161-A	XPYEMMYW161	8595A-EMMYW161
EMMY-W163	XPYEMMYW163	8595A-EMMYW163
EMMY-W163-A	XPYEMMYW163	8595A-EMMYW163
EMMY-W165	XPYEMMYW165	8595A-EMMYW165
EMMY-W165-A	XPYEMMYW165	8595A-EMMYW165

**Table 37: FCC and IC IDs for different models of EMMY-W1 series**

## 7.4 Certification in other countries

Regulatory approvals for using the EMMY-W1 series module in Japan, South Korea, China, Taiwan and Australia are pending.



## 8.2.2 Mounting process and soldering recommendations

The EMMY-W1 series module is a surface mount module supplied on a 4-layer FR4-type PCB with gold plated connection pins and produced in a lead-free process with a lead-free soldering paste. The wrap page of the PCB is max. 0,75% according to IPC-A-610E. The thickness of solder resist on the host PCB top side and the EMMY-W1 bottom side must be considered for the soldering process.

This module is compatible with industrial reflow profile for RoHS/Pb-free solders, Sn96.5/Ag3.0/Cu0.5 solder is a right choice. Use of "No Clean" soldering paste is strongly recommended, cleaning the populated modules is strongly discouraged - residuals under the module cannot be easily removed with any cleaning process. Cleaning with water can lead to capillary effects where water is absorbed into the gap between the host board and module. The combination of soldering flux residuals and encapsulated water could lead to short circuits between neighboring pins.

Only a single reflow soldering process is permitted for host boards with the EMMY-W1 series modules.

The reflow profile used is dependent on the thermal mass of the entire populated PCB, heat transfer efficiency of the oven and particular type of solder paste used. Since the profile used is process and layout dependent, the optimum profile should be studied case by case. Recommendations below should be taken as a starting point guide. In case of basic information necessity, please refer to J-STD-020C standard. }

Profile feature	Sn-Pb eutectic (Sn63/Pb37)	RoHS/Pb-free (Sn96.5/Ag3.0/Cu0.5)
Ramp up rate ( $T_{D50\%}$ to $T_p$ )	3 °C/Sec max	3 °C/Sec max
Minimum soak temperature ( $T_{min}$ )	100 °C	150 °C
Maximum soak temperature ( $T_{max}$ )	150 °C	200 °C
Soak time (ts)	60 - 120 sec	60 - 180 sec
Liquidus temperature ( $T_L$ )	183 °C	217 °C
Time above $T_L$ (t)	60 - 150 sec	60 - 150 sec
Peak temperature ( $T_p$ )	215 - 225 °C	235 - 245 °C
Time within +0 / -5°C of actual TP (tp)	10 - 30 sec	20 - 40 sec
Ramp down rate	6 °C/Sec max	6 °C/Sec max
Time from 25°C to $T_p$	6 min max	8 min max

**Table 38: Recommended reflow profile**



The lowest value of  $T_p$  and slower ramp down rate (2 – 3 °C/sec) is preferred.

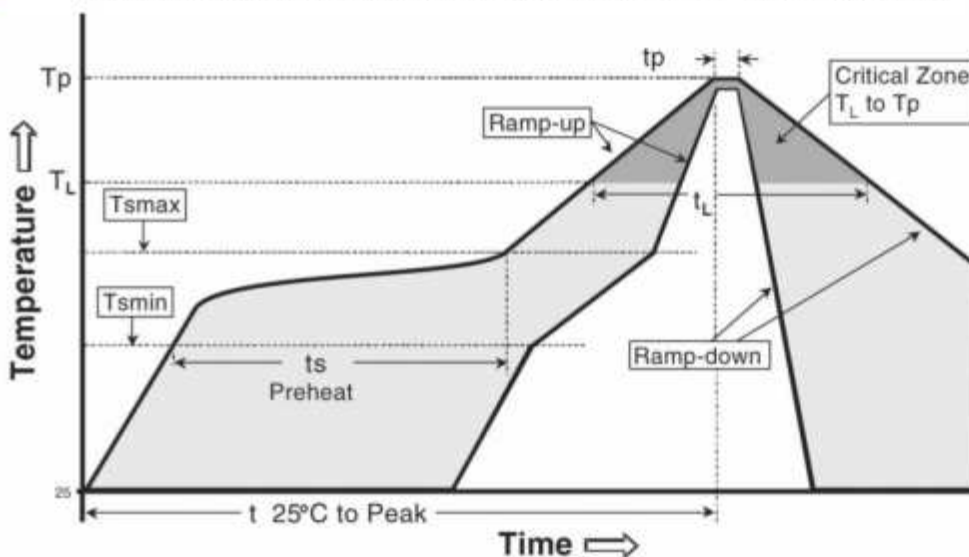

**Figure 15: Reflow profile**

### 8.2.3 ESD handling precautions

**⚠ EMMY-W1 series modules are Electrostatic Sensitive Devices (ESD). Observe precautions for handling! Failure to observe these precautions can result in severe damage to the Wi-Fi receiver!**

Wi-Fi transceivers are Electrostatic Sensitive Devices (ESD) and require special precautions when handling. Particular care must be exercised when handling patch antennas, due to the risk of electrostatic charges. In addition to standard ESD safety practices, the following measures should be taken into account whenever handling the receiver:

- Unless there is a galvanic coupling between the local GND (i.e. the work table) and the PCB GND, then the first point of contact when handling the PCB must always be between the local GND and PCB GND.
- Before mounting an antenna patch, connect ground of the device
- When handling the RF pin, do not come into contact with any charged capacitors and be careful when contacting materials that can develop charges (e.g. patch antenna ~10 pF, coax cable ~50-80 pF/m, soldering iron, ...)
- To prevent electrostatic discharge through the RF input, do not touch any exposed antenna area. If there is any risk that such exposed antenna area is touched in non ESD protected work area, implement proper ESD protection measures in the design.
- When soldering RF connectors and patch antennas to the receiver's RF pin, make sure to use an ESD safe soldering iron (tip).



## 9 Labeling and ordering information

### 9.1 Product labeling

The labels of EMMY-W1 series include important product information as described in this section. The data matrix code for automotive and professional grade variants of EMMY-W1 series includes a serial number.

Figure 16 illustrates the sample label of the automotive grade (professional grade is similar and differs with respect to product version (1) as mentioned in Table 39) of the EMMY-W1 series and includes: the u-blox logo, product name (model), type number, FCC and IC certification number and date of unit production encoded YY/WW (year/week).



Figure 16: EMMY-W1 series – Professional grade sample label

A detailed description of the label components are listed in Table 39. The first three digits of the serial number represent the Bluetooth MAC address.

Reference	Description
1	Text "MODEL:" followed by product type number, omitting the second dash and smaller font used for the product version identifier ("xxB-yy" for professional and "xxA-yy" for automotive grade).
2	Date of production encoded YY/WW (year/week)
3	FCC/IC ID which the module has been listed with
4	Data Matrix with unique serial number of 15 alphanumeric symbols. The 3 first symbols represent the unique module type no: 631: EMMY-W161-00A-00, 632: EMMY-W163-00A-00, 700: EMMY-W163-00B-00, 701: EMMY-W161-00B-00, 756: EMMY-W165-00A-00, 777: EMMY-W165-00B-00, , the next 8 symbols represent the unique hexadecimal Bluetooth MAC address (see section 1.7 for more information about MAC addresses) of the module AABBCDDEE, and the last 4 symbols represent the hardware and firmware version encoded HFFF.
5	u-blox logo, the red dot in the logo is also marking pin no 1

Table 39 EMMY-W1 series label description



## 9.2 Explanation of codes

Two different product code formats are used. The **Product Name** is used in documentation such as this data sheet and identifies all u-blox products, independent of packaging and quality grade. The **Ordering Code** includes options and quality, while the **Type Number** includes the hardware and firmware versions. Table 40 below details these three different formats:

Format	Structure
Product Name	PPPP-TG VV
Ordering Code	PPPP-TG VV-TTQ
Type Number	PPPP-TG VV-TTQ-XX

**Table 40: Product code formats**

Table 41 explains the parts of the product code.

Code	Meaning	Example
PPPP	Form factor	EMMY
TG	Platform T – Dominant technology, For example, W: Wi-Fi, B: Bluetooth G – Generation	W1
VV	Variant based on the same platform; range [00...99]	61
TT	Major Product Version	00
Q	Quality grade A: Automotive B: Professional C: Standard	A
XX	Minor product version (not relevant for certification)	00

**Table 41: Part identification code**

## 9.3 Ordering codes

Ordering Code	Product name	Product
EMMY-W161-00B	EMMY-W161	EMMY-W161 professional grade module
EMMY-W161-00A	EMMY-W161-A	EMMY-W161 automotive grade module
EMMY-W163-00B	EMMY-W163	EMMY-W163 professional grade module
EMMY-W163-00A	EMMY-W163-A	EMMY-W163 automotive grade module
EMMY-W165-00B	EMMY-W165	EMMY-W165 professional grade module
EMMY-W165-00A	EMMY-W165-A	EMMY-W165 automotive grade module
EVK-EMMY-W161-A	EVK-EMMY-W161	Evaluation kit for EMMY-W161 and EMMY-W161-A
EVK-EMMY-W163-A	EVK-EMMY-W163	Evaluation kit for EMMY-W163 and EMMY-W163-A

**Table 42: Product ordering codes**



Product changes affecting form, fit or function are documented by u-blox. For a list of Product Change Notifications (PCNs) see our website.

## Appendix

### A Glossary

Name	Definition
ACL	Access control list
AES	Advanced Encryption Standard
BPF	Band-Pass Filter
BT	Bluetooth
BAW	Bulk Acoustic Wave
CPU	Central Processing Unit
DTIM	Delivery traffic indication message
DC	Direct Current
DDR	Double Data Rate
ESD	Electrostatic Sensitive Devices
EMV	Europay, MasterCard and Visa
FCC	Federal Communications Commission
FIFO	First In, First Out
GI	Guard interval
GND	Ground
GPIO	General-purpose input/output
HD	High Definition
HCI	Host Controller Interface
IC	Industry Canada
IMDS	International Material Data System
IMEI	International Mobile Station Equipment Identity
LED	Light-emitting diode
LTE	Long Term Evolution
LE	Low Energy
MAC	Medium Access Control
MWS	Mobile Wireless Standards
MCS	Modulation Coding Scheme
MSL	Moisture sensitivity level
NFC	Near-Field Communication
NFCIP	NFC Interface and Protocol
OEM	Original equipment manufacturer
P2P	Peer-to-peer
PCB	Printed Circuit Board
PCN	Product Change Notification
PCM	Pulse-code modulation
R&TTE	Radio and telecommunications terminal equipment
RF	Radio Frequency
RSS	Radio Standards Specification
RH	Relative humidity
RoHS	Restriction of Hazardous Substances
SDIO	Secure Digital Input Output

Name	Definition
SDR	Secure Digital Rate
SMD	Surface-mount Device
SCO	Synchronous Connection-Oriented
UART	Universal Asynchronous Receiver/Transmitter

**Table 43: Explanation of abbreviations and terms used**

## Related documents

- [1] u-blox Package Information Guide, document number UBX-14001652
- [2] Driver Software Application Note for ELLA-W1 series and EMMY-W1 series, document number UBX-15012542
- [3] EMMY-W1 series System Integration Manual, document number UBX-15024929
- [4] Mixtus A10194 Product Specification, Antenova-M2M, <http://www.antenova-m2m.com/documents/download/40c67cf2e7a4c7b8cd0f7faed7f6d2ca4fe1886d597d5>, October 2015
- [5] ANT-DB1-RAF-xxx Data Sheet, Linx, <http://www.linxtechnologies.com/resources/data-guides/ant-db1-raf-xxx.pdf>, October 2015
- [6] Specification. Part No.: GW.40.2153, taoglas, <https://fccid.io/pdf.php?id=2415249>, December 2015
- [7] Specification. Part No.: GW.59.3153, taoglas, [http://www.taoglas.com/images/product\\_images/original\\_images/GW.59.3153-2.4GHz-5.8GHzBandMountDipoleAntenna080910.pdf](http://www.taoglas.com/images/product_images/original_images/GW.59.3153-2.4GHz-5.8GHzBandMountDipoleAntenna080910.pdf), October 2015
- [8] 2015 RF Devices and High Frequency Inductors Product catalog, [http://www.passivecomponent.com/document/HF\\_Devices/2013RF\\_Catalogue.pdf](http://www.passivecomponent.com/document/HF_Devices/2013RF_Catalogue.pdf), December 2015
- [9] ANT-2.4-CW-RCT-xx Data Sheet, Linx, <http://www.linxtechnologies.com/resources/data-guides/ant-2.4-cw-rct-xx.pdf>, October 2015
- [10] Delock WLAN 802.11ac/a/b/g/n Antenna RP-SMA 2 dBi Omnidirectional Joint, 2015-11-26 <http://www.delock.com/produkt/88395/pdf.html?sprache=en>, November 2015
- [11] 2.45 GHz High Gain SMD Chip Antenna P/N 2450AT45A100, Johanson Technology, <http://www.johansontechnology.com/datasheets/antennas/2450AT45A100.pdf>, October 2015
- [12] 2.4 GHz Miniature Screw mount Monopole Antenna, taoglas, [http://www.taoglas.com/images/product\\_images/original\\_images/GW.26.0112-2.4GHzBandMonopoleSMA%28M%29RA.pdf](http://www.taoglas.com/images/product_images/original_images/GW.26.0112-2.4GHzBandMonopoleSMA%28M%29RA.pdf), December 2015
- [13] ANT-2.4-CW-RH Data Sheet, Linx, <http://www.linxtechnologies.com/resources/data-guides/ant-2.4-cw-rh-xxx.pdf>, December 2015



For regular updates to u-blox documentation and to receive product change notifications, register on our homepage (<http://www.u-blox.ch/>).

## Revision history

Revision	Date	Name	Status / Comments
R01	23-June-2016	Daniel Dietherle	Draft
R02	01-July-2016	Daniel Dietherle	Document release after review
R03	05-July-2016	Daniel Dietherle	Corrected maximum output power for EMMY-W163 in Table 26 and Table 27

## Contact

For complete contact information visit us at [www.u-blox.com](http://www.u-blox.com)

### u-blox Offices

#### North, Central and South America

##### u-blox America, Inc.

Phone: +1 703 483 3 180  
E-mail: [info\\_us@u-blox.com](mailto:info_us@u-blox.com)

##### Regional Office West Coast:

Phone: +1 408 573 3 640  
E-mail: [info\\_us@u-blox.com](mailto:info_us@u-blox.com)

##### Technical Support:

Phone: +1 703 483 3 185  
E-mail: [support@u-blox.com](mailto:support@u-blox.com)

#### Headquarters

#### Europe, Middle East, Africa

##### u-blox AG

Phone: +41 44 722 74 44  
E-mail: [info@u-blox.com](mailto:info@u-blox.com)  
Support: [support@u-blox.com](mailto:support@u-blox.com)

#### Asia, Australia, Pacific

##### u-blox Singapore Pte. Ltd.

Phone: +65 6734 3811  
E-mail: [info\\_ap@u-blox.com](mailto:info_ap@u-blox.com)  
Support: [support\\_ap@u-blox.com](mailto:support_ap@u-blox.com)

##### Regional Office Australia:

Phone: +61 2 8448 2016  
E-mail: [info\\_anz@u-blox.com](mailto:info_anz@u-blox.com)  
Support: [support\\_ap@u-blox.com](mailto:support_ap@u-blox.com)

##### Regional Office China (Beijing):

Phone: +86 10 68 133 545  
E-mail: [info\\_cn@u-blox.com](mailto:info_cn@u-blox.com)  
Support: [support\\_cn@u-blox.com](mailto:support_cn@u-blox.com)

##### Regional Office China (Shenzhen):

Phone: +86 755 8627 1083  
E-mail: [info\\_cn@u-blox.com](mailto:info_cn@u-blox.com)  
Support: [support\\_cn@u-blox.com](mailto:support_cn@u-blox.com)

##### Regional Office India:

Phone: +91 959 1302 450  
E-mail: [info\\_in@u-blox.com](mailto:info_in@u-blox.com)  
Support: [support\\_in@u-blox.com](mailto:support_in@u-blox.com)

##### Regional Office Japan:

Phone: +81 3 5775 3850  
E-mail: [info\\_jp@u-blox.com](mailto:info_jp@u-blox.com)  
Support: [support\\_jp@u-blox.com](mailto:support_jp@u-blox.com)

##### Regional Office Korea:

Phone: +82 2 542 0861  
E-mail: [info\\_kr@u-blox.com](mailto:info_kr@u-blox.com)  
Support: [support\\_kr@u-blox.com](mailto:support_kr@u-blox.com)

##### Regional Office Taiwan:

Phone: +886 2 2657 1090  
E-mail: [info\\_tw@u-blox.com](mailto:info_tw@u-blox.com)  
Support: [support\\_tw@u-blox.com](mailto:support_tw@u-blox.com)