

TOBY-L2 and MPCII-L2 series

LTE/DC-HSPA+/EGPRS modules

System Integration Manual

Abstract

This document describes the features and the system integration of TOBY-L2 and MPCII-L2 series multi-mode cellular modules.

These modules are a complete and cost efficient LTE/3G/2G solution offering up to 150 Mb/s download and 50 Mb/s upload data rates, covering up to six LTE bands, up to five WCDMA/DC-HSPA+ bands and four GSM/EGPRS bands in the compact TOBY LGA form factor of TOBY-L2 modules or in the industry standard PCI Express Mini Card form factor of MPCII-L2 modules.



TOBY-L2 series



MPCII-L2 series

Document Information

Title	TOBY-L2 and MPC1-L2 series		
Subtitle	LTE/DC-HSPA+/EGPRS modules		
Document type	System Integration Manual		
Document number	UBX-13004618		
Revision and date	R08	29-Jun-2015	
Document status	Early Production Information		

Document status explanation

Objective Specification	Document contains target values. Revised and supplementary data will be published later.
Advance Information	Document contains data based on early testing. Revised and supplementary data will be published later.
Early Production Information	Document contains data from product verification. Revised and supplementary data may be published later.
Production Information	Document contains the final product specification.

This document applies to the following products:

Name	Type number	Modem version	Application version	PCN / IN
TOBY-L200	TOBY-L200-00S-00	09.71	A01.15	UBX-14044437
	TOBY-L200-50S-00	09.71	A01.57	UBX-15004131
TOBY-L201	TOBY-L201-01S-00	09.87	A01.01	UBX-15016217
TOBY-L210	TOBY-L210-00S-00	09.71	A01.15	UBX-14044437
	TOBY-L210-50S-00	09.71	A01.57	UBX-15004131
TOBY-L280	TOBY-L280-00S-00	09.90	A01.02	UBX-15016802
MPC1-L200	MPC1-L200-00S-00	09.71	A01.15	UBX-14044437
MPC1-L210	MPC1-L210-00S-00	09.71	A01.15	UBX-14044437

u-blox reserves all rights to this document and the information contained herein. Products, names, logos and designs described herein may in whole or in part be subject to intellectual property rights. Reproduction, use, modification or disclosure to third parties of this document or any part thereof without the express permission of u-blox is strictly prohibited.

The information contained herein is provided "as is" and u-blox assumes no liability for the use of the information. No warranty, either express or implied, is given, including but not limited, with respect to the accuracy, correctness, reliability and fitness for a particular purpose of the information. This document may be revised by u-blox at any time. For most recent documents, please visit www.u-blox.com.

Copyright © 2015, u-blox AG

u-blox® is a registered trademark of u-blox Holding AG in the EU and other countries. PCI, PCI Express, PCIe, and PCI-SIG are trademarks or registered trademarks of PCI-SIG. Microsoft and Windows are either registered trademarks or trademarks of Microsoft Corporation in the United States and/or other countries. ARM® is a registered trademark of ARM Limited in the EU and other countries. All other registered trademarks or trademarks mentioned in this document are property of their respective owners.

Preface

u-blox Technical Documentation

As part of our commitment to customer support, u-blox maintains an extensive volume of technical documentation for our products. In addition to our product-specific technical data sheets, the following manuals are available to assist u-blox customers in product design and development.

- **AT Commands Manual:** This document provides the description of the AT commands supported by the u-blox cellular modules.
- **System Integration Manual:** This document provides the description of u-blox cellular modules' system from the hardware and the software point of view, it provides hardware design guidelines for the optimal integration of the cellular modules in the application device and it provides information on how to set up production and final product tests on application devices integrating the cellular modules.
- **Application Note:** These documents provide guidelines and information on specific hardware and/or software topics on u-blox cellular modules. See Related documents for a list of Application Notes related to your Cellular Module.

How to use this Manual

The TOBY-L2 and MPC1-L2 series System Integration Manual provides the necessary information to successfully design and configure the u-blox cellular modules.

This manual has a modular structure. It is not necessary to read it from the beginning to the end.

The following symbols are used to highlight important information within the manual:



An index finger points out key information pertaining to module integration and performance.



A warning symbol indicates actions that could negatively impact or damage the module.

Questions

If you have any questions about u-blox Cellular Integration:

- Read this manual carefully.
- Contact our information service on the homepage <http://www.u-blox.com/>

Technical Support

Worldwide Web

Our website (<http://www.u-blox.com/>) is a rich pool of information. Product information, technical documents can be accessed 24h a day.

By E-mail

Contact the closest Technical Support office by email. Use our service pool email addresses rather than any personal email address of our staff. This makes sure that your request is processed as soon as possible. You will find the contact details at the end of the document.

Helpful Information when Contacting Technical Support

When contacting Technical Support, have the following information ready:

- Module type (TOBY-L200) and firmware version
- Module configuration
- Clear description of your question or the problem
- A short description of the application
- Your complete contact details

Contents

Preface	3
Contents.....	4
1 System description.....	8
1.1 Overview	8
1.2 Architecture.....	10
1.2.1 Internal blocks.....	11
1.3 Pin-out	12
1.3.1 TOBY-L2 series pin assignment	12
1.3.2 MPC1-L2 series pin assignment	17
1.4 Operating modes.....	19
1.5 Supply interfaces	21
1.5.1 Module supply input (VCC or 3.3Vaux)	21
1.5.2 RTC supply input/output (V_BCKP).....	28
1.5.3 Generic digital interfaces supply output (V_INT).....	29
1.6 System function interfaces.....	30
1.6.1 Module power-on	30
1.6.2 Module power-off.....	32
1.6.3 Module reset.....	34
1.6.4 Module configuration selection by host processor	34
1.7 Antenna interface.....	35
1.7.1 Antenna RF interfaces (ANT1 / ANT2).....	35
1.7.2 Antenna detection interface (ANT_DET)	38
1.8 SIM interface	38
1.8.1 SIM interface.....	38
1.8.2 SIM detection interface	38
1.9 Data communication interfaces	39
1.9.1 Universal Serial Bus (USB)	39
1.9.2 Asynchronous serial interface (UART).....	43
1.9.3 DDC (I ² C) interface	54
1.9.4 Secure Digital Input Output interface (SDIO).....	55
1.10 Audio.....	55
1.10.1 Digital audio over I ² S interface	55
1.11 General Purpose Input/Output	56
1.12 Mini PCIe specific signals (W_DISABLE#, LED_WWAN#)	57
1.13 Reserved pins (RSVD)	57
1.14 Not connected pins (NC)	57
1.15 System features.....	58
1.15.1 Network indication	58
1.15.2 Antenna supervisor	58

1.15.3	Jamming detection	58
1.15.4	IP modes of operation	59
1.15.5	Dual stack IPv4/IPv6	59
1.15.6	TCP/IP and UDP/IP	59
1.15.7	FTP	59
1.15.8	HTTP	60
1.15.9	SSL	60
1.15.10	AssistNow clients and GNSS integration	60
1.15.11	Hybrid positioning and CellLocate®	60
1.15.12	Wi-Fi integration	63
1.15.13	Firmware update Over AT (FOAT)	63
1.15.14	Firmware update Over The Air (FOTA)	63
1.15.15	In-band Modem (eCall / ERA-GLONASS)	64
1.15.16	SIM Access Profile (SAP)	64
1.15.17	Smart temperature management	66
1.15.18	Power saving	68
2	Design-in	69
2.1	Overview	69
2.2	Supply interfaces	70
2.2.1	Module supply (VCC or 3.3Vaux)	70
2.2.2	RTC supply output (V_BCKP)	82
2.2.3	Generic digital interfaces supply output (V_INT)	84
2.3	System functions interfaces	85
2.3.1	Module power-on (PWR_ON)	85
2.3.2	Module reset (RESET_N or PERST#)	86
2.3.3	Module configuration selection by host processor	87
2.4	Antenna interface	88
2.4.1	Antenna RF interfaces (ANT1 / ANT2)	88
2.4.2	Antenna detection interface (ANT_DET)	96
2.5	SIM interface	98
2.5.1	Guidelines for SIM circuit design	98
2.5.2	Guidelines for SIM layout design	104
2.6	Data communication interfaces	105
2.6.1	Universal Serial Bus (USB)	105
2.6.2	Asynchronous serial interface (UART)	107
2.6.3	DDC (I ² C) interface	111
2.6.4	Secure Digital Input Output interface (SDIO)	115
2.7	Audio interface	117
2.7.1	Digital audio interface	117
2.8	General Purpose Input/Output	119
2.9	Mini PCIe specific signals (W_DISABLE#, LED_WWAN#)	120
2.10	Reserved pins (RSVD)	121
2.11	Module placement	122

2.12	TOBY-L2 series module footprint and paste mask	123
2.13	MPCI-L2 series module installation	124
2.14	Thermal guidelines	126
2.15	ESD guidelines	127
2.15.1	ESD immunity test overview	127
2.15.2	ESD immunity test of TOBY-L2 and MPC1-L2 series reference designs	128
2.15.3	ESD application circuits	128
2.16	Schematic for TOBY-L2 and MPC1-L2 series module integration	130
2.16.1	Schematic for TOBY-L200-00S / TOBY-L210-00S	130
2.16.2	Schematic for TOBY-L201-01S / TOBY-L280-00S	131
2.16.3	Schematic for TOBY-L200-50S / TOBY-L210-50S	132
2.16.4	Schematic for MPC1-L2 series	133
2.17	Design-in checklist	134
2.17.1	Schematic checklist	134
2.17.2	Layout checklist	135
2.17.3	Antenna checklist	135
3	Handling and soldering	136
3.1	Packaging, shipping, storage and moisture preconditioning	136
3.2	Handling	136
3.3	Soldering	137
3.3.1	Soldering paste	137
3.3.2	Reflow soldering	137
3.3.3	Optical inspection	138
3.3.4	Cleaning	138
3.3.5	Repeated reflow soldering	139
3.3.6	Wave soldering	139
3.3.7	Hand soldering	139
3.3.8	Rework	139
3.3.9	Conformal coating	139
3.3.10	Casting	139
3.3.11	Grounding metal covers	139
3.3.12	Use of ultrasonic processes	139
4	Approvals	140
4.1	Product certification approval overview	140
4.2	Federal Communications Commission notice	141
4.2.1	Safety warnings review the structure	141
4.2.2	Declaration of Conformity	141
4.2.3	Modifications	142
4.3	Industry Canada notice	142
4.3.1	Declaration of Conformity	143
4.3.2	Modifications	143
4.4	Anatel certification	144
4.5	R&TTED and European Conformance CE mark	145

5	Product testing	146
5.1	u-blox in-series production test	146
5.2	Test parameters for OEM manufacturer	147
5.2.1	“Go/No go” tests for integrated devices	147
5.2.2	RF functional tests	147
	Appendix	149
A	Glossary	149
B	Migration between TOBY-L1 and TOBY-L2	151
B.1	Overview	151
B.2	Pin-out comparison between TOBY-L1 and TOBY-L2	153
B.3	Schematic for TOBY-L1 and TOBY-L2 integration	155
	Related documents	156
	Revision history	157
	Contact	158

1 System description

1.1 Overview

TOBY-L2 and MPC1-L2 series comprises LTE/3G/2G multi-mode modules supporting up to six LTE bands, up to five UMTS/DC-HSPA+ bands and up to four GSM/(E)GPRS bands for voice and/or data transmission as following:

- TOBY-L200, TOBY-L201 and MPC1-L200 are designed primarily for operation in America
- TOBY-L210 and MPC1-L210 are designed primarily for operation in Europe, Asia and other countries
- TOBY-L280 is mainly designed for operation in Asia and Oceania

TOBY-L2 and MPC1-L2 series are designed in two different form-factors suitable for applications as following:

- TOBY-L2 modules are designed in the small TOBY 152-pin Land Grid Array form-factor (35.6 x 24.8 mm), easy to integrate in compact designs and form-factor compatible with the u-blox cellular module families: this allows customers to take the maximum advantage of their hardware and software investments, and provides very short time-to-market.
- MPC1-L2 modules are designed in the industry standard PCI Express Full-Mini Card form-factor (51 x 30 mm) easy to integrate into industrial and consumer applications and also ideal for manufacturing of small series.

With LTE Category 4 data rates at up to 150 Mb/s (down-link) and 50 Mb/s (up-link), the TOBY-L2 and MPC1-L2 series modules are ideal for applications requiring the highest data-rates and high-speed internet access.

Table 1 summarizes the TOBY-L2 and MPC1-L2 series main features and interfaces.

Module	LTE	UMTS	GSM	Positioning	Interfaces	Audio	Features	Grade
	LTE FDD category Bands	HSDPA category HSUPA category Bands	GPRS/EDGE multi-slot class Bands	GNSS receiver GNSS via modem Assist Now Software CellLocate®	UART USB 2.0 SDIO (Master) DCC (I ² C) GPIOs	Analog audio Digital audio	Network indication Antenna supervisor MIMO 2x2 / Rx Diversity Jamming detection Embedded TCP/UDP stack Embedded HTTP,FTP FOTA eCall / ERA GLONASS Dual stack IPv4/IPv6	Standard Professional Automotive
TOBY-L200	4 2,4,5 7,17	24 6 850/900 AWS 1900/2100	12 Quad	F F F	○ ● ○ F F	F	□ F ● F F F F F ●	
TOBY-L201	4 2,4,5 13,17	24 6 850/1900		F F F	● ● F F F	F	● F ● F ● ● ● F ●	
TOBY-L210	4 1,3,5 7,8,20	24 6 850/900 1900/2100	12 Quad	F F F	○ ● ○ F F	F	□ F ● F F F F F ●	
TOBY-L280	4 1,3,5, 7,8,28	24 6 850/900 1900/2100	12 Quad	F F F	● ● F F F	F	● F ● F F F F F ●	
MPC1-L200	4 2,4,5 7,17	24 6 850/900 AWS 1900/2100	12 Quad		●		● ● F F F F ●	
MPC1-L210	4 1,3,5 7,8,20	24 6 850/900 1900/2100	12 Quad		●		● ● F F F F ●	

- = supported by all product versions □ = supported by all product versions except product version "50"
○ = supported by product version "50" and future product versions F = supported by future product versions

Table 1: TOBY-L2 and MPC1-L2 series main features summary

Table 2 reports a summary of cellular radio access technologies characteristics and features of the modules.

4G LTE	3G UMTS/HSDPA/HSUPA	2G GSM/GPRS/EDGE
3GPP Release 9 Long Term Evolution (LTE) Evolved Uni.Terrestrial Radio Access (E-UTRA) Frequency Division Duplex (FDD) DL Multi-Input Multi-Output (MIMO) 2 x 2	3GPP Release 8 Dual-Cell HS Packet Access (DC-HSPA+) UMTS Terrestrial Radio Access (UTRA) Frequency Division Duplex (FDD) DL Rx diversity	3GPP Release 8 Enhanced Data rate GSM Evolution (EDGE) GSM EGPRS Radio Access (GERA) Time Division Multiple Access (TDMA) DL Advanced Rx Performance (DARF) Phase 1
Band support: <ul style="list-style-type: none"> TOBY-L200: <ul style="list-style-type: none"> Band 17 (700 MHz) Band 5 (850 MHz) Band 4 (AWS, i.e. 1700 MHz) Band 2 (1900 MHz) Band 7 (2600 MHz) TOBY-L201: <ul style="list-style-type: none"> Band 17 (700 MHz) Band 13 (750 MHz) Band 5 (850 MHz) Band 4 (AWS, i.e. 1700 MHz) Band 2 (1900 MHz) TOBY-L210: <ul style="list-style-type: none"> Band 20 (800 MHz) Band 5 (850 MHz) Band 8 (900 MHz) Band 3 (1800 MHz) Band 1 (2100 MHz) Band 7 (2600 MHz) TOBY-L280: <ul style="list-style-type: none"> Band 28 (750 MHz) Band 5 (850 MHz) Band 8 (900 MHz) Band 3 (1800 MHz) Band 1 (2100 MHz) Band 7 (2600 MHz) 	Band support: <ul style="list-style-type: none"> TOBY-L200: <ul style="list-style-type: none"> Band 5 (850 MHz) Band 8 (900 MHz) Band 4 (AWS, i.e. 1700 MHz) Band 2 (1900 MHz) Band 1 (2100 MHz) TOBY-L201: <ul style="list-style-type: none"> Band 5 (850 MHz) Band 2 (1900 MHz) TOBY-L210: <ul style="list-style-type: none"> Band 5 (850 MHz) Band 8 (900 MHz) Band 2 (1900 MHz) Band 1 (2100 MHz) TOBY-L280: <ul style="list-style-type: none"> Band 5 (850 MHz) Band 8 (900 MHz) Band 2 (1900 MHz) Band 1 (2100 MHz) 	Band support <ul style="list-style-type: none"> TOBY-L200: <ul style="list-style-type: none"> GSM 850 MHz E-GSM 900 MHz DCS 1800 MHz PCS 1900 MHz TOBY-L210: <ul style="list-style-type: none"> GSM 850 MHz E-GSM 900 MHz DCS 1800 MHz PCS 1900 MHz TOBY-L280: <ul style="list-style-type: none"> GSM 850 MHz E-GSM 900 MHz DCS 1800 MHz PCS 1900 MHz
LTE Power Class <ul style="list-style-type: none"> Power Class 3 (23 dBm) for LTE mode 	WCDMA/HSDPA/HSUPA Power Class <ul style="list-style-type: none"> Power Class 3 (24 dBm) for UMTS/HSDPA/HSUPA mode 	GSM/GPRS (GMSK) Power Class <ul style="list-style-type: none"> Power Class 4 (33 dBm) for GSM/E-GSM bands Power Class 1 (30 dBm) for DCS/PCS bands EDGE (8-PSK) Power Class <ul style="list-style-type: none"> Power Class E2 (27 dBm) for GSM/E-GSM bands Power Class E2 (26 dBm) for DCS/PCS bands
Data rate <ul style="list-style-type: none"> LTE category 4: up to 150 Mb/s DL, 50 Mb/s UL 	Data rate <ul style="list-style-type: none"> TOBY-L200 / MPC1-L200: <ul style="list-style-type: none"> HSDPA cat.14, up to 21 Mb/s DL¹ HSUPA cat.6, up to 5.6 Mb/s UL TOBY-L210 / MPC1-L210: <ul style="list-style-type: none"> HSDPA cat.24, up to 42 Mb/s DL HSUPA cat.6, up to 5.6 Mb/s UL 	Data rate ² <ul style="list-style-type: none"> GPRS multi-slot class 12³, CS1-CS4, up to 85.6 kb/s DL/UL EDGE multi-slot class 12³, MCS1-MCS9 up to 236.8 kb/s DL/UL

Table 2: TOBY-L2 and MPC1-L2 series LTE, 3G and 2G characteristics summary

¹ HSDPA category 24 capable

² GPRS/EDGE multi-slot class determines the number of timeslots available for upload and download and thus the speed at which data can be transmitted and received, with higher classes typically allowing faster data transfer rates.

³ GPRS/EDGE multi-slot class 12 implies a maximum of 4 slots in DL (reception) and 4 slots in UL (transmission) with 5 slots in total.

1.2 Architecture

Figure 1 summarizes the internal architecture of TOBY-L2 series modules.

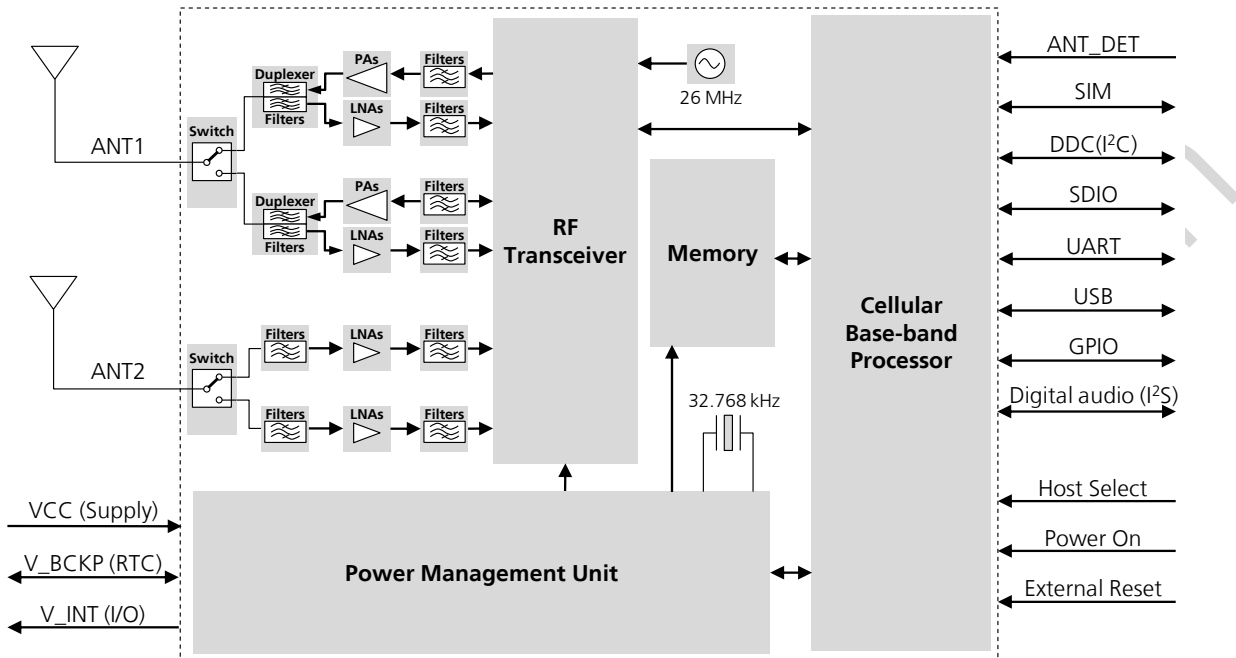

Figure 1: TOBY-L2 series block diagram

As described in the Figure 2, each MPC1-L2 series module integrates one TOBY-L2 series module:

- The MPC1-L200 integrates a TOBY-L200 module
- The MPC1-L210 integrates a TOBY-L210 module

The TOBY-L2 module represents the core of the device, providing the related LTE/3G/2G modem and processing functionalities. Additional signal conditioning circuitry is implemented for PCI Express Mini Card compliance, and two U.F.L connectors are available for easy antenna integration.

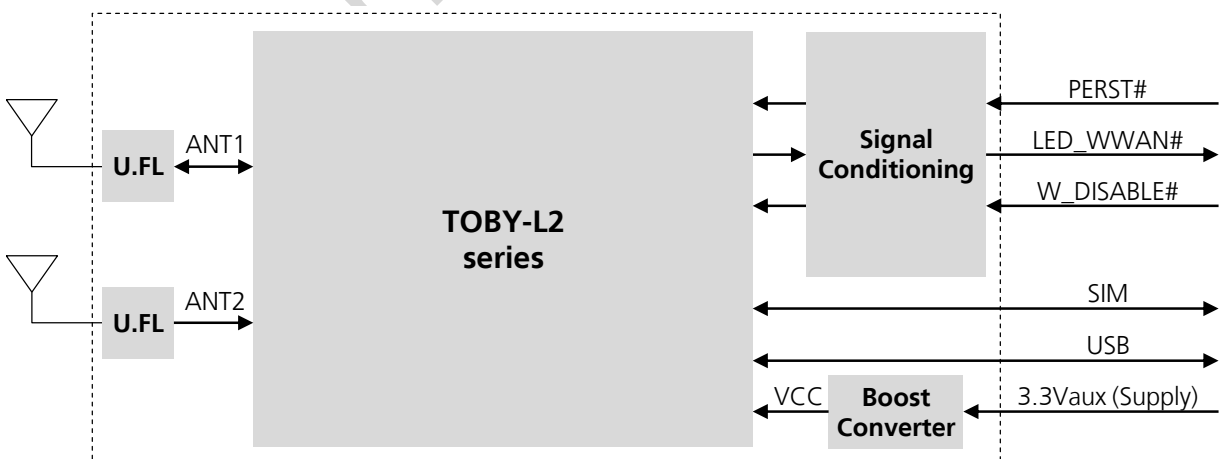

Figure 2: MPC1-L2 series block diagram

1.2.1 Internal blocks

As described in Figure 2, each MPC1-L2 series module integrates one TOBY-L2 series module, which consists of the following internal sections: RF, baseband and power management.

RF section

The RF section is composed of RF transceiver, PAs, LNAs, crystal oscillator, filters, duplexers and RF switches.

Tx signal is pre-amplified by RF transceiver, then output to the primary antenna input/output port (**ANT1**) of the module via power amplifier (PA), SAW band pass filters band, specific duplexer and antenna switch.

Dual receiving paths are implemented according to LTE Down-Link MIMO 2 x 2 and 3G Receiver Diversity radio technologies supported by the modules as LTE category 4 and HSDPA category 24 User Equipments: incoming signals are received through the primary (**ANT1**) and the secondary (**ANT2**) antenna input ports which are connected to the RF transceiver via specific antenna switch, diplexer, duplexer, LNA, SAW band pass filters.

- RF transceiver performs modulation, up-conversion of the baseband I/Q signals for Tx, down-conversion and demodulation of the dual RF signals for Rx. The RF transceiver contains:
 - Automatically gain controlled direct conversion Zero-IF receiver,
 - Highly linear RF demodulator / modulator capable GMSK, 8-PSK, QPSK, 16-QAM, 64-QAM,
 - Fractional-N Sigma-Delta RF synthesizer,
 - VCO.
- Power Amplifiers (PA) amplify the Tx signal modulated by the RF transceiver
- RF switches connect primary (**ANT1**) and secondary (**ANT2**) antenna ports to the suitable Tx / Rx path
- Low Noise Amplifiers (LNA) enhance the received sensitivity
- SAW duplexers separate the Tx and Rx signal paths and provide RF filtering
- SAW band pass filters enhance the rejection of out-of-band signals
- 26 MHz crystal oscillator generates the clock reference in active-mode or connected-mode.

Baseband and power management section

The Baseband and Power Management section is composed of the following main elements:

- A mixed signal ASIC, which integrates
 - Microprocessor for control functions
 - DSP core for LTE/3G/2G Layer 1 and digital processing of Rx and Tx signal paths
 - Memory interface controller
 - Dedicated peripheral blocks for control of the USB, SIM and GPIO digital interfaces
 - Analog front end interfaces to RF transceiver ASIC
- Memory system, which includes NAND flash and LPDDR
- Voltage regulators to derive all the subsystem supply voltages from the module supply input **VCC**
- Voltage sources for external use: **V_BCKP** and **V_INT** (not available on MPC1-L2 series modules)
- Hardware power on
- Hardware reset
- Low power idle-mode support
- 32.768 kHz crystal oscillator to provide the clock reference in the low power idle-mode, which can be set by enable power saving configuration using the AT+UPSV command.

1.3 Pin-out

1.3.1 TOBY-L2 series pin assignment

Table 3 lists the pin-out of the TOBY-L2 series modules, with pins grouped by function.

Function	Pin Name	Pin No	I/O	Description	Remarks
Power	VCC	70,71,72	I	Module supply input	VCC pins are internally connected each other. VCC supply circuit affects the RF performance and compliance of the device integrating the module with applicable required certification schemes. See section 1.5.1 for functional description and requirements for the VCC module supply. See section 2.2.1 for external circuit design-in.
	GND	2, 30, 32, 44, 46, 69, 73, 74, 76, 78, 79, 80, 82, 83, 85, 86, 88-90, 92-152	N/A	Ground	GND pins are internally connected each other. External ground connection affects the RF and thermal performance of the device. See section 1.5.1 for functional description. See section 2.2.1 for external circuit design-in.
	V_BCKP	3	I/O	RTC supply input/output	V_BCKP = 3.0 V (typical) generated by internal regulator when valid VCC supply is present. See section 1.5.2 for functional description. See section 2.2.2 for external circuit design-in.
	V_INT	5	O	Generic digital interfaces supply output	V_INT = 1.8 V (typical) generated by internal regulator when the module is switched on. See section 1.5.3 for functional description. See section 2.2.3 for external circuit design-in.
System	PWR_ON	20	I	Power-on input	Internal active pull-up to the VCC enabled. See section 1.6.1 for functional description. See section 2.3.1 for external circuit design-in.
	RESET_N	23	I	External reset input	Internal active pull-up to the VCC enabled. See section 1.6.3 for functional description. See section 2.3.2 for external circuit design-in.
	HOST_SELECT0	26	I	Selection of module configuration by the host processor	Note: Not supported by "00", "01", "50" product versions. See section 1.6.4 for functional description. See section 2.3.3 for external circuit design-in.
	HOST_SELECT1	62	I	Selection of module configuration by the host processor	Note: Not supported by "00", "01", "50" product versions. See section 1.6.4 for functional description. See section 2.3.3 for external circuit design-in.
Antennas	ANT1	81	I/O	Primary antenna	Main Tx / Rx antenna interface. 50 Ω nominal characteristic impedance. Antenna circuit affects the RF performance and application device compliance with required certification schemes. See section 1.7 for functional description / requirements. See section 2.4 for external circuit design-in.
	ANT2	87	I	Secondary antenna	Rx only for MIMO 2x2 and Rx diversity. 50 Ω nominal characteristic impedance. Antenna circuit affects the RF performance and application device compliance with required certification schemes. See section 1.7 for functional description / requirements. See section 2.4 for external circuit design-in.
	ANT_DET	75	I	Antenna detection	Note: not supported by "00", "01", "50" product versions. See section 1.7.2 for functional description. See section 2.4.2 for external circuit design-in.

Function	Pin Name	Pin No	I/O	Description	Remarks
SIM	VSIM	59	O	SIM supply output	VSIM = 1.8 V / 3 V output as per the connected SIM type. See section 1.8 for functional description. See section 2.5 for external circuit design-in.
	SIM_IO	57	I/O	SIM data	Data input/output for 1.8 V / 3 V SIM. Internal 4.7 k Ω pull-up to VSIM . See section 1.8 for functional description. See section 2.5 for external circuit design-in.
	SIM_CLK	56	O	SIM clock	3.25 MHz clock output for 1.8 V / 3 V SIM. See section 1.8 for functional description. See section 2.5 for external circuit design-in.
	SIM_RST	58	O	SIM reset	Reset output for 1.8 V / 3 V SIM. See section 1.8 for functional description. See section 2.5 for external circuit design-in.
USB	VUSB_DET	4	I	USB detect input	Note: leave unconnected, as VBUS detect is not supported. Input for VBUS (5 V typical) USB supply sense. See section 1.9.1 for functional description. See section 2.6.1 for external circuit design-in.
	USB_D-	27	I/O	USB Data Line D-	USB interface for AT commands, data communication, FOAT, FW update by u-blox EasyFlash tool and diagnostic. 90 Ω nominal differential impedance (Z_0) 30 Ω nominal common mode impedance (Z_{CM}) Pull-up or pull-down resistors and external series resistors as required by the USB 2.0 specifications [4] are part of the USB pad driver and need not be provided externally. See section 1.9.1 for functional description. See section 2.6.1 for external circuit design-in.
	USB_D+	28	I/O	USB Data Line D+	USB interface for AT commands, data communication, FOAT, FW update by u-blox EasyFlash tool and diagnostic. 90 Ω nominal differential impedance (Z_0) 30 Ω nominal common mode impedance (Z_{CM}) Pull-up or pull-down resistors and external series resistors as required by the USB 2.0 specifications [4] are part of the USB pad driver and need not be provided externally. See section 1.9.1 for functional description. See section 2.6.1 for external circuit design-in.

Function	Pin Name	Pin No	I/O	Description	Remarks
UART	RXD	17	O	UART data output	Note: not supported by TOBY-L200-00S, TOBY-L210-00S. 1.8 V output, Circuit 104 (RXD) in ITU-T V.24, for AT command, data communication, FOAT. Add Test-Point and series 0 Ω to access for diagnostic. See section 1.9.2 for functional description. See section 2.6.2 for external circuit design-in.
	TXD	16	I	UART data input	Note: not supported by TOBY-L200-00S, TOBY-L210-00S. 1.8 V input, Circuit 103 (TXD) in ITU-T V.24, for AT command, data communication, FOAT. Internal active pull-up to V_INT . Add Test-Point and series 0 Ω to access for diagnostic. See section 1.9.2 for functional description. See section 2.6.2 for external circuit design-in.
	CTS	15	O	UART clear to send output	Note: not supported by TOBY-L200-00S, TOBY-L210-00S. 1.8 V output, Circuit 106 (CTS) in ITU-T V.24. Add Test-Point and series 0 Ω to access for diagnostic. See section 1.9.2 for functional description. See section 2.6.2 for external circuit design-in.
	RTS	14	I	UART ready to send input	Note: not supported by TOBY-L200-00S, TOBY-L210-00S. 1.8 V input, Circuit 105 (RTS) in ITU-T V.24. Internal active pull-up to V_INT . Add Test-Point and series 0 Ω to access for diagnostic. See section 1.9.2 for functional description. See section 2.6.2 for external circuit design-in.
	DSR	10	O / I/O	UART data set ready output / GPIO	Note: UART DSR not supported by TOBY-L200-00S, TOBY-L210-00S, TOBY-L200-50S, TOBY-L210-50S; GPIO not supported by "00", "01", "50" product versions. 1.8 V, Circuit 107 in ITU-T V.24, configurable as GPIO. Add Test-Point and series 0 Ω to access for diagnostic. See section 1.9.2 and 1.11 for functional description. See section 2.6.2 and 2.8 for external circuit design-in.
	RI	11	O / I/O	UART ring indicator output / GPIO	Note: RI not supported by TOBY-L200-00S, TOBY-L210-00S; GPIO not supported by "00", "01", "50" product versions. 1.8 V, Circuit 125 in ITU-T V.24, configurable as GPIO. Add Test-Point and series 0 Ω to access for diagnostic. See section 1.9.2 and 1.11 for functional description. See section 2.6.2 and 2.8 for external circuit design-in.
	DTR	13	I / I/O	UART data terminal ready input / GPIO	Note: UART DTR not supported by TOBY-L200-00S, TOBY-L210-00S, TOBY-L200-50S, TOBY-L210-50S; GPIO not supported by "00", "01", "50" product versions. 1.8 V, Circuit 108/2 in ITU-T V.24, configurable as GPIO. Internal active pull-up to V_INT when configured as DTR. Add Test-Point and series 0 Ω to access for diagnostic. See section 1.9.2 and 1.11 for functional description. See section 2.6.2 and 2.8 for external circuit design-in.
	DCD	12	O / I/O	UART data carrier detect output / GPIO	Note: UART DCD not supported by TOBY-L200-00S, TOBY-L210-00S, TOBY-L200-50S, TOBY-L210-50S; GPIO not supported by "00", "01", "50" product versions. 1.8 V, Circuit 109 in ITU-T V.24, configurable as GPIO. Add Test-Point and series 0 Ω to access for diagnostic. See section 1.9.2 and 1.11 for functional description. See section 2.6.2 and 2.8 for external circuit design-in.

Function	Pin Name	Pin No	I/O	Description	Remarks
DDC	SCL	54	O	I ² C bus clock line	Note: not supported by "00", "01", "50" product versions. 1.8 V open drain, for communication with u-blox GNSS receivers and other I2C-slave devices as an audio codec. External pull-up required. See section 1.9.3 for functional description. See section 2.6.3 for external circuit design-in.
	SDA	55	I/O	I ² C bus data line	Note: not supported by "00", "01", "50" product versions. 1.8 V open drain, for communication with u-blox GNSS receivers and other I2C-slave devices as an audio codec. External pull-up required. See section 1.9.3 for functional description. See section 2.6.3 for external circuit design-in.
SDIO	SDIO_D0	66	I/O	SDIO serial data [0]	Note: not supported by "00", "01" product versions. SDIO interface for communication with external Wi-Fi chip See section 1.9.4 for functional description. See section 2.6.4 for external circuit design-in.
	SDIO_D1	68	I/O	SDIO serial data [1]	Note: not supported by "00", "01" product versions. SDIO interface for communication with external Wi-Fi chip See section 1.9.4 for functional description. See section 2.6.4 for external circuit design-in.
	SDIO_D2	63	I/O	SDIO serial data [2]	Note: not supported by "00", "01" product versions. SDIO interface for communication with external Wi-Fi chip See section 1.9.4 for functional description. See section 2.6.4 for external circuit design-in.
	SDIO_D3	67	I/O	SDIO serial data [3]	Note: not supported by "00", "01" product versions. SDIO interface for communication with external Wi-Fi chip See section 1.9.4 for functional description. See section 2.6.4 for external circuit design-in.
	SDIO_CLK	64	O	SDIO serial clock	Note: not supported by "00", "01" product versions. SDIO interface for communication with external Wi-Fi chip See section 1.9.4 for functional description. See section 2.6.4 for external circuit design-in.
	SDIO_CMD	65	I/O	SDIO command	Note: not supported by "00", "01" product versions. SDIO interface for communication with external Wi-Fi chip See section 1.9.4 for functional description. See section 2.6.4 for external circuit design-in.
	Audio	I2S_TXD	51	O / I/O	I ² S transmit data / GPIO
I2S_RXD		53	I / I/O	I ² S receive data / GPIO	Note: not supported by "00", "01", "50" product versions. I ² S receive data input, alternatively configurable as GPIO. See sections 1.10 and 1.11 for functional description. See sections 2.7 and 2.8 for external circuit design-in.
I2S_CLK		52	I/O / I/O	I ² S clock / GPIO	Note: not supported by "00", "01", "50" product versions. I ² S serial clock, alternatively configurable as GPIO. See sections 1.10 and 1.11 for functional description. See sections 2.7 and 2.8 for external circuit design-in.
I2S_WA		50	I/O / I/O	I ² S word alignment / GPIO	Note: not supported by "00", "01", "50" product versions. I ² S word alignment, alternatively configurable as GPIO. See sections 1.10 and 1.11 for functional description. See sections 2.7 and 2.8 for external circuit design-in.

Function	Pin Name	Pin No	I/O	Description	Remarks
GPIO	GPIO1	21	I/O	GPIO	Note: not supported by "00", "01", "50" product versions. WWAN status indication set on "00", "01" product versions. Wi-Fi enable function set on "50" product version. 1.8 V GPIO with alternatively configurable functions See section 1.11 for functional description. See section 2.8 for external circuit design-in.
	GPIO2	22	I/O	GPIO	Note: not supported by "00", "01", "50" product versions. 1.8 V GPIO with alternatively configurable functions See section 1.11 for functional description. See section 2.8 for external circuit design-in.
	GPIO3	24	I/O	GPIO	Note: not supported by "00", "01", "50" product versions. 1.8 V GPIO with alternatively configurable functions See section 1.11 for functional description. See section 2.8 for external circuit design-in.
	GPIO4	25	I/O	GPIO	Note: not supported by "00", "01", "50" product versions. 1.8 V GPIO with alternatively configurable functions See section 1.11 for functional description. See section 2.8 for external circuit design-in.
	GPIO5	60	I/O	GPIO	Note: not supported by "00", "01", "50" product versions. 1.8 V GPIO with alternatively configurable functions See section 1.11 for functional description. See section 2.8 for external circuit design-in.
	GPIO6	61	I/O	GPIO	Note: not supported by "00", "01", "50" product versions. 1.8 V GPIO with alternatively configurable functions See section 1.11 for functional description. See section 2.8 for external circuit design-in.
Reserved	RSVD	6	N/A	Reserved pin	This pin must be connected to ground. See section 2.10
	RSVD	1, 7-9, 18, 19, 29, 31, 33-43, 45, 47-49, 77, 84, 91	N/A	Reserved pin	Leave unconnected. See section 2.10

Table 3: TOBY-L2 series module pin definition, grouped by function

1.3.2 MPC1-L2 series pin assignment

Table 4 lists the pin-out of the MPC1-L2 series modules, with pins grouped by function.

Function	Pin Name	Pin No	I/O	Description	Remarks
Power	3.3Vaux	2, 24, 39, 41, 52	I	Module supply input	3.3Vaux pins are internally connected each other. 3.3Vaux supply circuit affects the RF performance and compliance of the device integrating the module with applicable required certification schemes. See section 1.5.1 for functional description and requirements for the 3.3Vaux module supply. See section 2.2.1 for external circuit design-in.
	GND	4, 9, 15, 18, 21, 26, 27, 29, 34, 35, 37, 40, 43, 50	N/A	Ground	GND pins are internally connected each other. External ground connection affects the RF and thermal performance of the device. See section 1.5.1 for functional description. See section 2.2.1 for external circuit design-in.
Auxiliary Signals	PERST#	22	I	External reset input	Internal 45 k Ω pull-up to 3.3 V supply. See section 1.6.3 for functional description. See section 2.3.2 for external circuit design-in.
Antennas	ANT1	U.FL	I/O	Primary antenna	Main Tx / Rx antenna interface. 50 Ω nominal characteristic impedance. Antenna circuit affects the RF performance and compliance of the device integrating the module with applicable required certification schemes. See section 1.7 for functional description / requirements. See section 2.4 for external circuit design-in.
	ANT2	U.FL	I	Secondary antenna	Rx only for MIMO 2x2 and Rx diversity. 50 Ω nominal characteristic impedance. Antenna circuit affects the RF performance and compliance of the device integrating the module with applicable required certification schemes. See section 1.7 for functional description / requirements. See section 2.4 for external circuit design-in.
SIM	UIM_PWR	8	O	SIM supply output	UIM_PWR = 1.8 V / 3 V automatically generated according to the connected SIM type. See section 1.8 for functional description. See section 2.5 for external circuit design-in.
	UIM_DATA	10	I/O	SIM data	Data input/output for 1.8 V / 3 V SIM. Internal 4.7 k Ω pull-up to UIM_PWR . See section 1.8 for functional description. See section 2.5 for external circuit design-in.
	UIM_CLK	12	O	SIM clock	3.25 MHz clock output for 1.8 V / 3 V SIM. See section 1.8 for functional description. See section 2.5 for external circuit design-in.
	UIM_RESET	14	O	SIM reset	Reset output for 1.8 V / 3 V SIM. See section 1.8 for functional description. See section 2.5 for external circuit design-in.

Function	Pin Name	Pin No	I/O	Description	Remarks
USB	USB_D-	36	I/O	USB Data Line D-	USB interface for AT commands, data communication, FOAT, FW update by u-blox EasyFlash tool and diagnostic. 90 Ω nominal differential impedance (Z_D) 30 Ω nominal common mode impedance (Z_{CM}) Pull-up or pull-down resistors and external series resistors as required by the USB 2.0 specifications [4] are part of the USB pad driver and need not be provided externally. See section 1.9.1 for functional description. See section 2.6.1 for external circuit design-in.
	USB_D+	38	I/O	USB Data Line D+	USB interface for AT commands, data communication, FOAT, FW update by u-blox EasyFlash tool and diagnostic. 90 Ω nominal differential impedance (Z_D) 30 Ω nominal common mode impedance (Z_{CM}) Pull-up or pull-down resistors and external series resistors as required by the USB 2.0 specifications [4] are part of the USB pad driver and need not be provided externally. See section 1.9.1 for functional description. See section 2.6.1 for external circuit design-in.
Specific Signals	LED_WWAN#	42	O	LED indicator output	Open drain active low output. See section 1.12 for functional description. See section 2.9 for external circuit design-in.
	W_DISABLE#	20	I	Wireless radio disable input	Internal 22 k Ω pull-up to 3.3Vaux . See section 1.12 for functional description. See section 2.9 for external circuit design-in.
Not Connected	NC	1, 3, 5-7, 11, 13, 16, 17, 19, 23, 25, 28, 30-33, 44-46, 47-49, 51	N/A	Not connected	Internally not connected. See section 1.14 for the description.

Table 4: MPC1-L2 series module pin definition, grouped by function

1.4 Operating modes

TOBY-L2 and MPC1-L2 series modules have several operating modes. The operating modes are defined in Table 5 and described in detail in Table 6, providing general guidelines for operation.

General Status	Operating Mode	Definition
Power-down	Not-Powered Mode	VCC or 3.3Vaux supply not present or below operating range: module is switched off.
	Power-Off Mode	VCC or 3.3Vaux supply within operating range and module is switched off.
Normal Operation	Idle-Mode	Module processor core runs with 32 kHz reference generated by the internal oscillator.
	Active-Mode	Module processor core runs with 26 MHz reference generated by the internal oscillator.
	Connected-Mode	RF Tx/Rx data connection enabled and processor core runs with 26 MHz reference.

Table 5: TOBY-L2 and MPC1-L2 series modules operating modes definition

Operating Mode	Description	Transition between operating modes
Not-Powered Mode	Module is switched off. Application interfaces are not accessible.	When VCC or 3.3Vaux supply is removed, the modules enter not-powered mode. When in not-powered mode, TOBY-L2 modules cannot be switched on by PWR_ON , RESET_N or RTC alarm and enter active-mode after applying VCC supply (see 1.6.1). When in not-powered mode, MPC1-L2 modules cannot be switched on by RTC alarm and enter active-mode after applying 3.3Vaux supply (see 1.6.1).
Power-Off Mode	Module is switched off: normal shutdown by an appropriate power-off event (see 1.6.2). Application interfaces are not accessible. MPC1-L2 modules do not support Power-Off Mode but halt mode (see 1.6.2 and u-blox AT Commands Manual [3], AT+CFUN=127 command).	When the modules are switched off by an appropriate power-off event (see 1.6.2), the modules enter power-off mode from active-mode. When in power-off mode, TOBY-L2 modules can be switched on by PWR_ON , RESET_N or an RTC alarm. When in power-off mode, TOBY-L2 modules enter the not-powered mode after removing VCC supply.
Idle-Mode	Module is switched on with application interfaces disabled or suspended: the module is temporarily not ready to communicate with an external device by means of the application interfaces as configured to reduce the current consumption. The module enters the low power idle-mode whenever possible if power saving is enabled by AT+UPSV (see u-blox AT Commands Manual [3]) reducing current consumption (see 1.5.1.5). With HW flow control enabled and AT+UPSV=1 or AT+UPSV=3, the UART CTS line indicates when the UART is enabled (see 1.9.2.3, 1.9.2.4). With HW flow control disabled, the UART CTS line is fixed to ON state (see 1.9.2.3). Power saving configuration is not enabled by default: it can be enabled by the AT+UPSV command (see the u-blox AT Commands Manual [3]).	The modules automatically switch from active-mode to low power idle-mode whenever possible if power saving is enabled (see sections 1.5.1.5, 1.9.1.4, 1.9.2.4 and u-blox AT Commands Manual [3], AT+UPSV). The modules wake up from idle-mode to active-mode in the following events: <ul style="list-style-type: none"> • Automatic periodic monitoring of the paging channel for the paging block reception according to network conditions (see 1.5.1.5) • The connected USB host forces a remote wakeup of the module as USB device (see 1.9.1.4) • Automatic periodic enable of the UART interface to receive / send data, with AT+UPSV=1 (see 1.9.2.4) • Data received on UART interface, with HW flow control disabled and AT+UPSV=1 (see 1.9.2.4) • RTS input set ON by the host DTE, with HW flow control disabled and AT+UPSV=2 (see 1.9.2.4) • DTR input set ON by the host DTE, with AT+UPSV=3 (see 1.9.2.4) • The connected SDIO device forces a wakeup of the module as SDIO host (see 1.9.4) • A preset RTC alarm occurs (see u-blox AT Commands Manual [3], AT+CALA)

Operating Mode	Description	Transition between operating modes
Active-Mode	Module is switched on with application interfaces enabled or not suspended: the module is ready to communicate with an external device by means of the application interfaces unless power saving configuration is enabled by AT+UPSV (see 1.9.1.4, 1.9.2.4 and u-blox AT Commands Manual [3]).	<p>When the modules are switched on by an appropriate power-on event (see 1.6.1), the module enter active-mode from power-off mode.</p> <p>If power saving configuration is enabled by the AT+UPSV command, the module automatically switches from active to idle-mode whenever possible and the module wakes up from idle to active-mode in the events listed above (see idle-mode to active-mode transition description above).</p> <p>When a RF Tx/Rx data connection is initiated or when RF Tx/Rx is required due to a connection previously initiated, the module switches from active to connected-mode.</p>
Connected-Mode	RF Tx/Rx data connection is in progress. The module is prepared to accept data signals from an external device unless power saving configuration is enabled by AT+UPSV (see sections 1.9.1.4, 1.9.2.4 and u-blox AT Commands Manual [3]).	<p>When a data connection is initiated, the module enters connected-mode from idle-mode.</p> <p>If power saving configuration is enabled by the AT+UPSV command, the module automatically switches from connected to active and then idle-mode whenever possible and the module wakes up from idle to active and then connected mode if RF Transmission/Reception is necessary.</p> <p>When a data connection is terminated, the module returns to the active-mode.</p>

Table 6: TOBY-L2 and MPC1-L2 series modules operating modes description

Figure 3 describes the transition between the different operating modes.

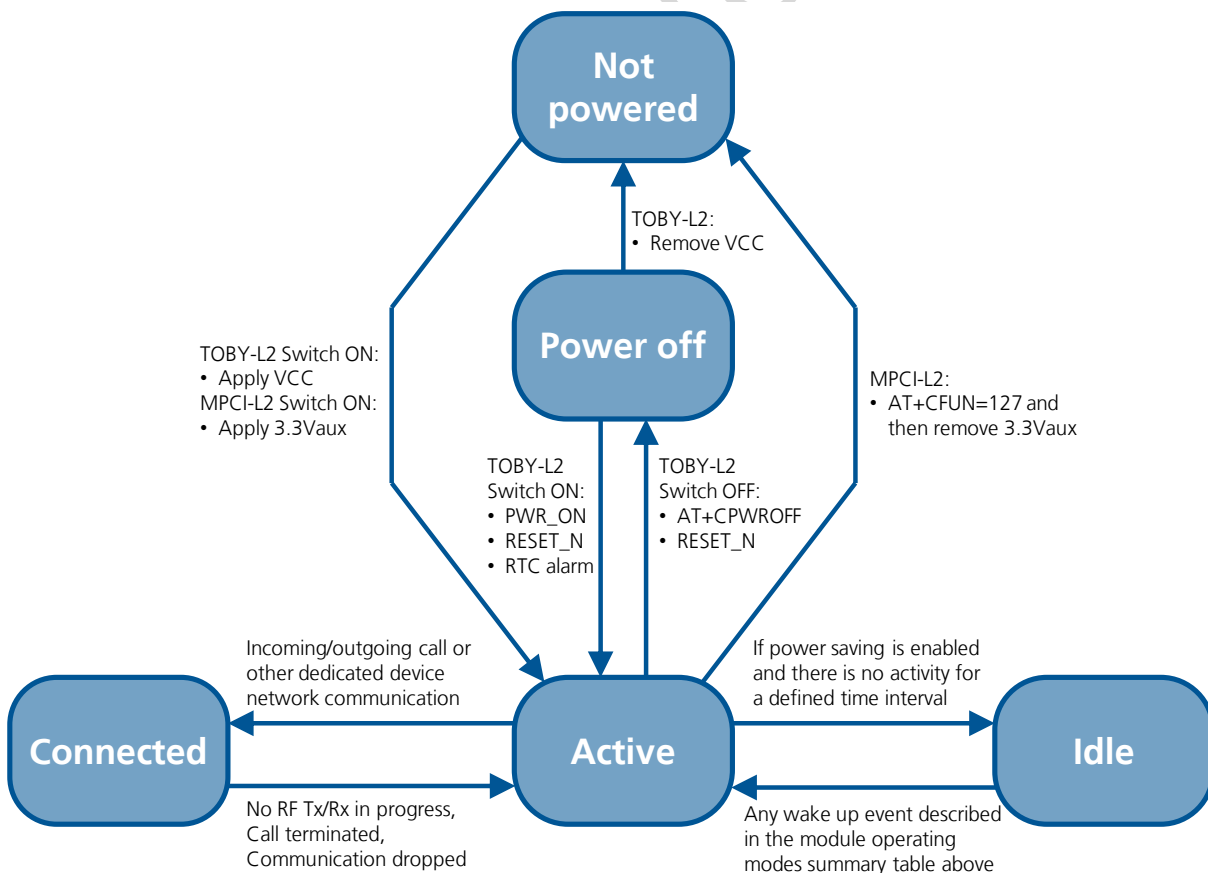
Figure 3: TOBY-L2 and MPC1-L2 series modules operating modes transition

1.5 Supply interfaces

1.5.1 Module supply input (VCC or 3.3Vaux)

TOBY-L2 modules are supplied via the three **VCC** pins, and MPC1-L2 modules are supplied via the five **3.3Vaux** pins. All supply voltages used inside the modules are generated from the **VCC** or the **3.3Vaux** supply input by integrated voltage regulators, including the **V_BCKP** RTC supply, the **V_INT** generic digital interface supply, and the **VSIM** or **UIM_PWR** SIM interface supply.

The current drawn by the TOBY-L2 and MPC1-L2 series modules through the **VCC** or **3.3Vaux** pins can vary by several orders of magnitude depending on radio access technology, operation mode and state. It is important that the supply source is able to support both the high peak of current consumption during 2G transmission at maximum RF power level (as described in the section 1.5.1.2) and the high average current consumption during 3G and LTE transmission at maximum RF power level (as described in the sections 1.5.1.3 and 1.5.1.4).

1.5.1.1 VCC or 3.3Vaux supply requirements

Table 7 summarizes the requirements for the **VCC** or **3.3Vaux** modules supply. See section 2.2.1 for suggestions to properly design a **VCC** or **3.3Vaux** supply circuit compliant with the requirements listed in Table 7.

 **The supply circuit affects the RF compliance of the device integrating TOBY-L2 and MPC1-L2 series modules with applicable required certification schemes as well as antenna circuit design. Compliance is guaranteed if the requirements summarized in the Table 7 are fulfilled.**

Item	Requirement	Remark
VCC or 3.3Vaux nominal voltage	Within VCC or 3.3Vaux normal operating range: See "Supply/Power pins" section in the TOBY-L2 Data Sheet [1] or in the MPC1-L2 Data Sheet [2].	The modules cannot be switched on if the supply voltage is below the normal operating range minimum limit.
VCC or 3.3Vaux voltage during normal operation	Within VCC or 3.3Vaux extended operating range: See "Supply/Power pins" section in the TOBY-L2 Data Sheet [1] or in the MPC1-L2 Data Sheet [2].	The modules may switch off if the supply voltage drops below the extended operating range minimum limit.
VCC or 3.3Vaux average current	Support with adequate margin the highest averaged current consumption value in connected-mode conditions specified for VCC in TOBY-L2 Data Sheet [1] or specified for 3.3Vaux in MPC1-L2 Data Sheet [2].	The maximum average current consumption can be greater than the specified value according to the actual antenna mismatching, temperature and supply voltage. Sections 1.5.1.2, 1.5.1.3 and 1.5.1.4 describe current consumption profiles in 2G, 3G and LTE connected-mode.
VCC or 3.3Vaux peak current	Support with margin the highest peak current consumption value in 2G connected-mode conditions specified for VCC in TOBY-L2 Data Sheet [1] or specified for 3.3Vaux in MPC1-L2 Data Sheet [2].	The specified maximum peak of current consumption occurs during GSM single transmit slot in 850/900 MHz connected-mode, in case of mismatched antenna. Section 1.5.1.2 describes 2G Tx peak/pulse current.
VCC or 3.3Vaux voltage drop during 2G Tx slots	Lower than 400 mV	Supply voltage drop values greater than recommended during 2G TDMA transmission slots directly affect the RF compliance with applicable certification schemes. Figure 5 describes supply voltage drop during 2G Tx slots.
VCC or 3.3Vaux voltage ripple during RF transmission	Noise in the supply has to be minimized	High supply voltage ripple values during LTE/3G/2G RF transmissions in connected-mode directly affect the RF compliance with applicable certification schemes. Figure 5 describes supply voltage ripple during RF Tx.
VCC or 3.3Vaux under/over-shoot at start/end of Tx slots	Absent or at least minimized	Supply voltage under-shoot or over-shoot at the start or the end of 2G TDMA transmission slots directly affect the RF compliance with applicable certification schemes. Figure 5 describes supply voltage under/over-shoot

Table 7: Summary of VCC or 3.3Vaux modules supply requirements

1.5.1.2 VCC or 3.3Vaux current consumption in 2G connected-mode

When a GSM call is established, the **VCC** or **3.3Vaux** module current consumption is determined by the current consumption profile typical of the GSM transmitting and receiving bursts.

The peak of current consumption during a transmission slot is strictly dependent on the RF transmitted power, which is regulated by the network. The transmitted power in the transmit slot is also the more relevant factor for determining the average current consumption.

If the module is transmitting in 2G single-slot mode in the 850 or 900 MHz bands, at the maximum RF power level (approximately 2 W or 33 dBm in the allocated transmit slot/burst) the current consumption can reach a high peak (see the “Current consumption” section in the TOBY-L2 Data Sheet [1] or the MPC1-L2 Data Sheet [2]) for 576.9 μ s (width of the transmit slot/burst) with a periodicity of 4.615 ms (width of 1 frame = 8 slots/burst), so with a 1/8 duty cycle according to GSM TDMA (Time Division Multiple Access).

If the module is transmitting in 2G single-slot mode in the 1800 or 1900 MHz bands, the current consumption figures are quite less high than the one in the low bands, due to 3GPP transmitter output power specifications.

During a GSM call, current consumption is not so significantly high in receiving or in monitor bursts and is low in the inactive unused bursts.

Figure 4 shows an example of the module current consumption profile versus time in 2G single-slot mode.

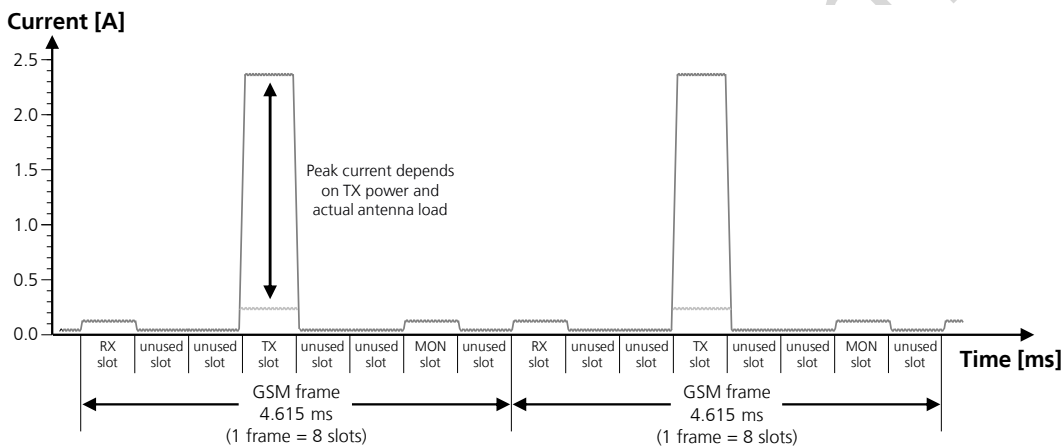

Figure 4: VCC or 3.3Vaux current consumption profile versus time during a 2G single-slot call (1 TX slot, 1 RX slot)

Figure 5 illustrates **VCC** or **3.3Vaux** voltage profile versus time during a 2G single-slot call, according to the relative **VCC** or **3.3Vaux** current consumption profile described in Figure 4.

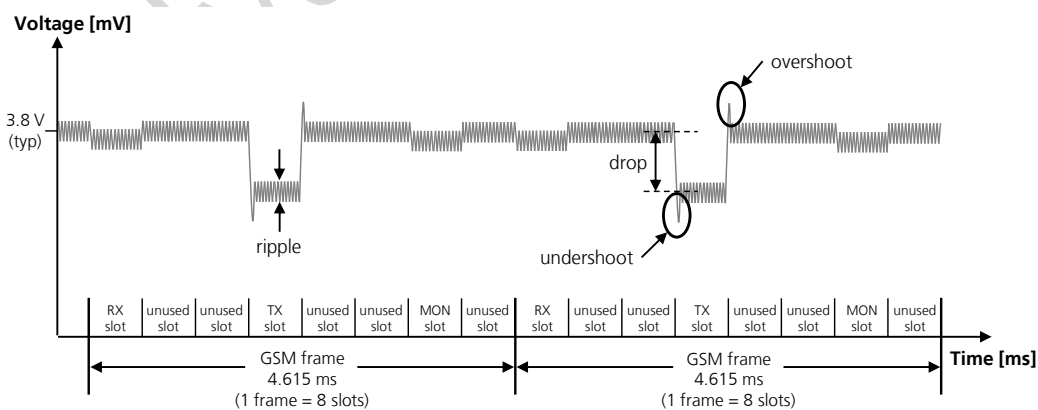

Figure 5: VCC or 3.3Vaux voltage profile versus time during a 2G single-slot call (1 TX slot, 1 RX slot)

When a GPRS connection is established, more than one slot can be used to transmit and/or more than one slot can be used to receive. The transmitted power depends on network conditions, which set the peak current consumption, but following the 3GPP specifications the maximum Tx RF power is reduced if more than one slot is used to transmit, so the maximum peak of current is not as high as can be in case of a 2G single-slot call.

If the module transmits in GPRS class 12 in the 850 or 900 MHz bands, at the maximum RF power control level, the current consumption can reach a quite high peak but lower than the one achievable in 2G single-slot mode. This happens for 2.307 ms (width of the 4 transmit slots/bursts) with a periodicity of 4.615 ms (width of 1 frame = 8 slots/bursts), so with a 1/2 duty cycle, according to 2G TDMA.

If the module is in GPRS connected mode in the 1800 or 1900 MHz bands, the current consumption figures are quite less high than the one in the low bands, due to 3GPP transmitter output power specifications.

Figure 6 reports the current consumption profiles in GPRS class 12 connected mode, in the 850 or 900 MHz bands, with 4 slots used to transmit and 1 slot used to receive.

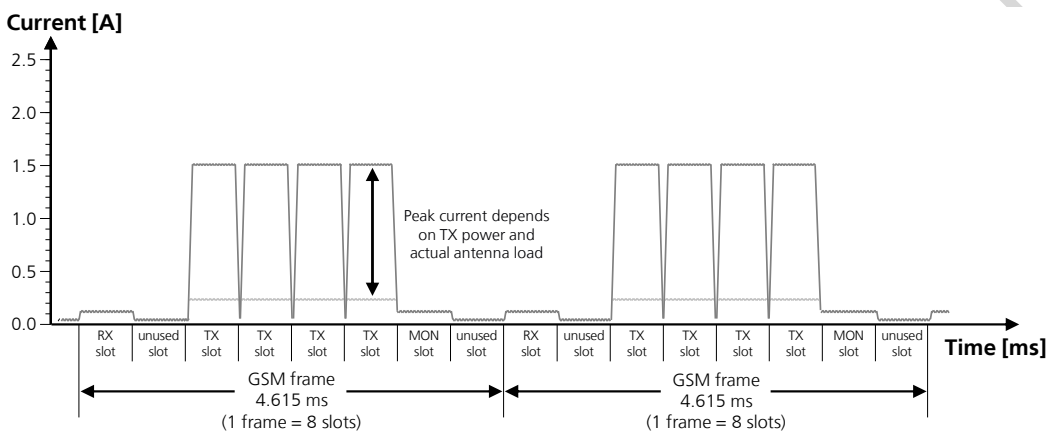

Figure 6: VCC or 3.3Vaux current consumption profile during a 2G GPRS/EDGE multi-slot connection (4 TX slots, 1 RX slot)

In case of EDGE connections the VCC current consumption profile is very similar to the GPRS current profile, so the image shown in Figure 6, representing the current consumption profile in GPRS class 12 connected mode, is valid for the EDGE class 12 connected mode as well.

1.5.1.3 VCC or 3.3Vaux current consumption in 3G connected mode

During a 3G connection, the module can transmit and receive continuously due to the Frequency Division Duplex (FDD) mode of operation with the Wideband Code Division Multiple Access (WCDMA).

The current consumption depends again on output RF power, which is always regulated by network commands. These power control commands are logically divided into a slot of 666 μ s, thus the rate of power change can reach a maximum rate of 1.5 kHz.

There are no high current peaks as in the 2G connection, since transmission and reception are continuously enabled due to FDD WCDMA implemented in the 3G that differs from the TDMA implemented in the 2G case.

In the worst scenario, corresponding to a continuous transmission and reception at maximum output power (approximately 250 mW or 24 dBm), the average current drawn by the module at the VCC pins is high (see the "Current consumption" section in TOBY-L2 Data Sheet [1] or in MPC1-L2 Data Sheet [2]). Even at lowest output RF power (approximately 0.01 μ W or -50 dBm), the current is still not so low due to module baseband processing and transceiver activity.

Figure 7 shows an example of current consumption profile of the module in 3G WCDMA/DC-HSPA+ continuous transmission mode.

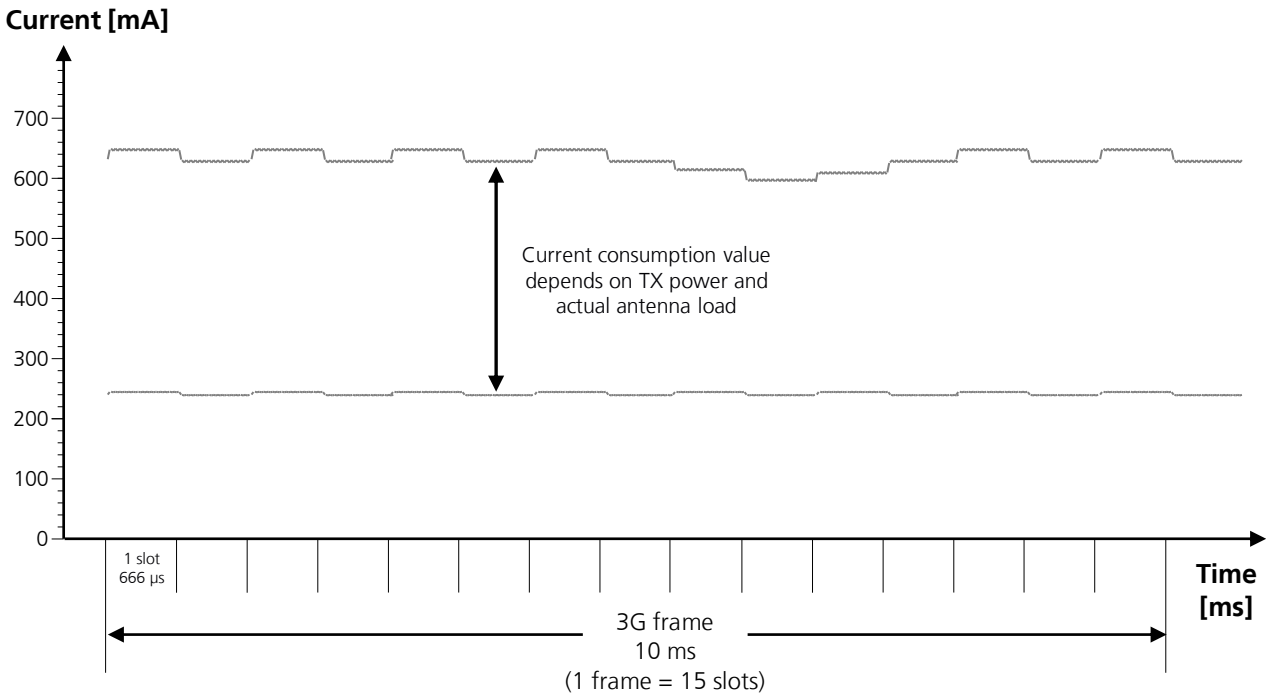

Figure 7: VCC or 3.3Vaux current consumption profile versus time during a 3G connection (TX and RX continuously enabled)

1.5.1.4 VCC or 3.3Vaux current consumption in LTE connected-mode

During a LTE connection, the module can transmit and receive continuously due to LTE radio access technology. The current consumption is strictly dependent on the transmitted RF output power, which is always regulated by network commands. These power control commands are logically divided into a slot of 0.5 ms (time length of one Resource Block), thus the rate of power change can reach a maximum rate of 2 kHz.

Figure 8 shows an example of the module current consumption profile versus time in LTE connected-mode. Detailed current consumption values can be found in TOBY-L2 Data Sheet [1] and in MPC1-L2 Data Sheet [2].

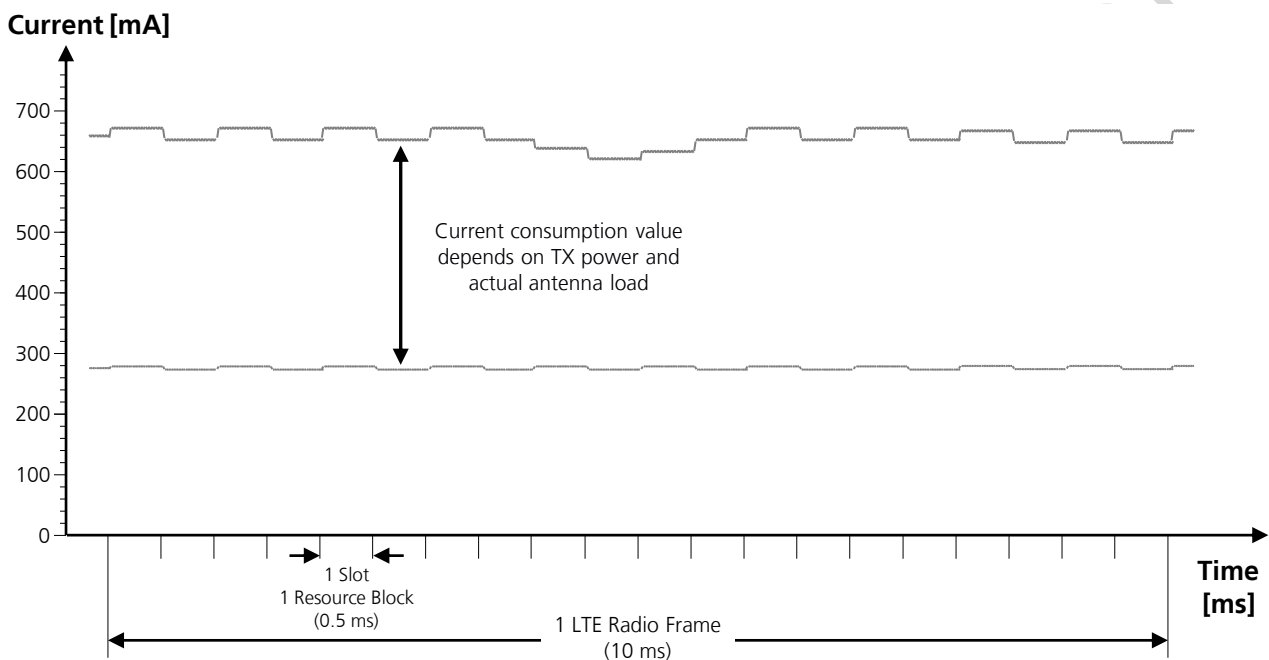

Figure 8: VCC or 3.3Vaux current consumption profile versus time during LTE connection (TX and RX continuously enabled)

1.5.1.5 VCC or 3.3Vaux current consumption in cyclic idle/active mode (power saving enabled)

The power saving configuration is by default disabled, but it can be enabled using the AT+UPSV command (see the u-blox AT Commands Manual [3]). When power saving is enabled, the module automatically enters the low power idle-mode whenever possible, reducing current consumption.

During low power idle-mode, the module processor runs with 32 kHz reference clock frequency.

When the power saving configuration is enabled and the module is registered or attached to a network, the module automatically enters the low power idle-mode whenever possible, but it must periodically monitor the paging channel of the current base station (paging block reception), in accordance to the 2G/3G/LTE system requirements, even if connected-mode is not enabled by the application. When the module monitors the paging channel, it wakes up to the active-mode, to enable the reception of paging block. In between, the module switches to low power idle-mode. This is known as discontinuous reception (DRX).

The module processor core is activated during the paging block reception, and automatically switches its reference clock frequency from 32 kHz to the 26 MHz used in active-mode.

The time period between two paging block receptions is defined by the network. This is the paging period parameter, fixed by the base station through broadcast channel sent to all users on the same serving cell:

- In case of 2G radio access technology, the paging period can vary from 470.8 ms (DRX = 2, length of 2 x 51 2G frames = 2 x 51 x 4.615 ms) up to 2118.4 ms (DRX = 9, length of 9 x 51 2G frames = 9 x 51 x 4.615 ms)
- In case of 3G radio access technology, the paging period can vary from 640 ms (DRX = 6, i.e. length of 2⁶ 3G frames = 64 x 10 ms) up to 5120 ms (DRX = 9, length of 2⁹ 3G frames = 512 x 10 ms).
- In case of LTE radio access technology, the paging period can vary from 320 ms (DRX = 5, i.e. length of 2⁵ LTE frames = 32 x 10 ms) up to 2560 ms (DRX = 8, length of 2⁸ LTE frames = 256 x 10 ms).

Figure 9 illustrates a typical example of the module current consumption profile when power saving is enabled. The module is registered with network, automatically enters the low power idle-mode and periodically wakes up to active-mode to monitor the paging channel for the paging block reception. Detailed current consumption values can be found in TOBY-L2 Data Sheet [1] and in MPC1-L2 Data Sheet [2].

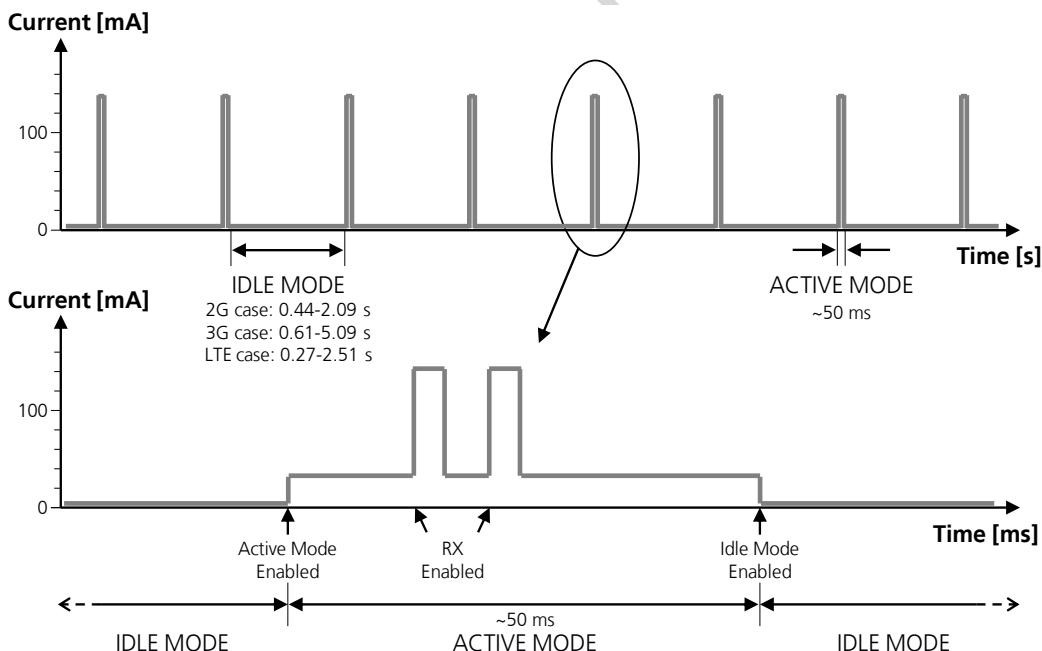

Figure 9: VCC or 3.3Vaux current consumption profile with power saving enabled and module registered with the network: the module is in idle-mode and periodically wakes up to active-mode to monitor the paging channel for paging block reception

1.5.1.6 VCC or 3.3Vaux current consumption in fixed active-mode (power saving disabled)

When power saving is disabled, the module does not automatically enter the low power idle-mode whenever possible: the module remains in active-mode. Power saving configuration is by default disabled. It can also be disabled using the AT+UPSV command (see u-blox AT Commands Manual [3] for detail usage).

The module processor core is activated during idle-mode, and the 26 MHz reference clock frequency is used. It would draw more current during the paging period than that in the power saving mode.

Figure 10 illustrates a typical example of the module current consumption profile when power saving is disabled. In such case, the module is registered with the network and while active-mode is maintained, the receiver is periodically activated to monitor the paging channel for paging block reception. Detailed current consumption values can be found in TOBY-L2 Data Sheet [1] and in MPC1-L2 Data Sheet [2].

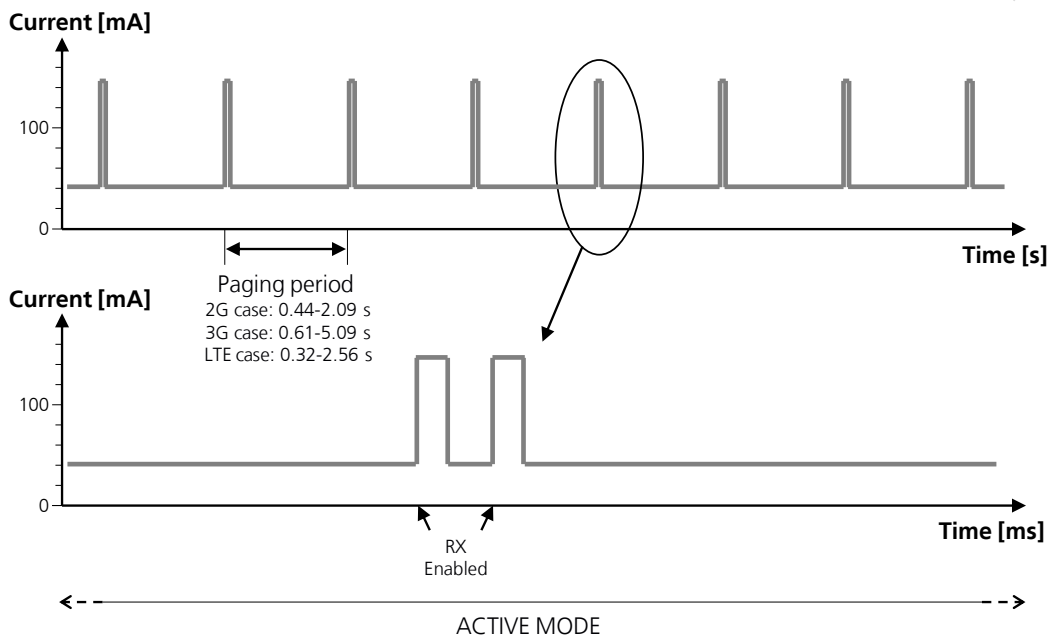

Figure 10: VCC or 3.3Vaux current consumption profile with power saving disabled and module registered with the network: active-mode is always held and the receiver is periodically activated to monitor the paging channel for paging block reception

1.5.2 RTC supply input/output (V_BCKP)



The RTC supply **V_BCKP** pin is not available on MPC1-L2 series modules.

The **V_BCKP** pin of TOBY-L2 series modules connects the supply for the Real Time Clock (RTC). A linear LDO regulator integrated in the Power Management Unit internally generates this supply, as shown in Figure 11, with low current capability (see the TOBY-L2 series Data Sheet [1]). The output of this regulator is always enabled when the main module voltage supply applied to the **VCC** pins is within the valid operating range.

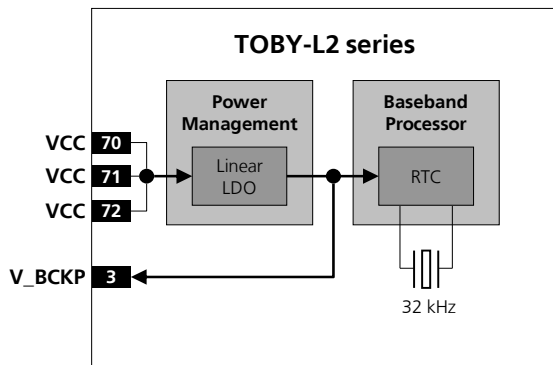

Figure 11: TOBY-L2 series RTC supply (V_BCKP) simplified block diagram

The RTC provides the module time reference (date and time) that is used to set the wake-up interval during the low power idle-mode periods, and is able to make available the programmable alarm functions.

The RTC functions are available also in power-down mode when the **V_BCKP** voltage is within its valid range (specified in the "Input characteristics of Supply/Power pins" table in TOBY-L2 series Data Sheet [1]). The RTC can be supplied from an external back-up battery through the **V_BCKP**, when the main module voltage supply is not applied to the **VCC** pins. This lets the time reference (date and time) run until the **V_BCKP** voltage is within its valid range, even when the main supply is not provided to the module.

Consider that the module cannot switch on if a valid voltage is not present on **VCC** even when the RTC is supplied through **V_BCKP** (meaning that **VCC** is mandatory to switch on the module).

The RTC has very low current consumption, but is highly temperature dependent. For example, **V_BCKP** current consumption at the maximum operating temperature can be higher than the typical value at 25 °C specified in the "Input characteristics of Supply/Power pins" table in the TOBY-L2 series Data Sheet [1].

If **V_BCKP** is left unconnected and the module main supply is not applied to the **VCC** pins, the RTC is supplied from the bypass capacitor mounted inside the module. However, this capacitor is not able to provide a long buffering time: within few milliseconds the voltage on **V_BCKP** will go below the valid range (1.4 V min). This has no impact on cellular connectivity, as all the module functionalities do not rely on date and time setting.

1.5.3 Generic digital interfaces supply output (V_INT)



The generic digital interfaces supply **V_INT** pin is not available on MPC1-L2 series modules.

The **V_INT** output pin of the TOBY-L2 series modules is connected to an internal 1.8 V supply with current capability specified in the TOBY-L2 series Data Sheet [1]. This supply is internally generated by a switching step-down regulator integrated in the Power Management Unit and it is internally used to source the generic digital I/O interfaces of the TOBY-L2 module, as described in Figure 12. The output of this regulator is enabled when the module is switched on and it is disabled when the module is switched off.

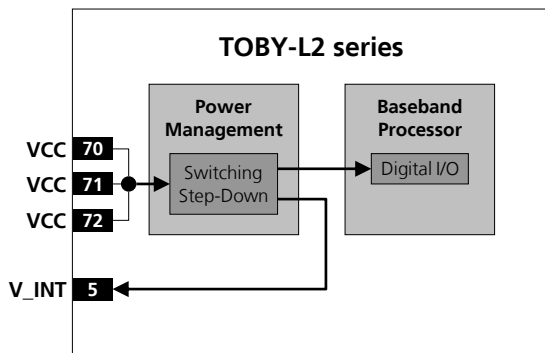

Figure 12: TOBY-L2 series generic digital interfaces supply output (V_INT) simplified block diagram

The switching regulator operates in Pulse Width Modulation (PWM) mode for greater efficiency at high output loads and it automatically switches to Pulse Frequency Modulation (PFM) power save mode for greater efficiency at low output loads. The **V_INT** output voltage ripple is specified in the TOBY-L2 series Data Sheet [1].

1.6 System function interfaces

1.6.1 Module power-on



The **PWR_ON** input pin is not available on MPC1-L2 series modules.

When the TOBY-L2 and MPC1-L2 series modules are in the not-powered mode (switched off, i.e. the **VCC** or **3.3Vaux** module supply is not applied), they can be switched on as following:

- Rising edge on the **VCC** or **3.3Vaux** supply input to a valid voltage for module supply, so that the module switches on applying a proper **VCC** or **3.3Vaux** supply within the normal operating range.
- Alternately, the **RESET_N** or **PERST#** pin can be held to the low level during the **VCC** or **3.3Vaux** rising edge, so that the module switches on releasing the **RESET_N** or **PERST#** pin when the **VCC** or **3.3Vaux** module supply voltage stabilizes at its proper nominal value within the normal operating range.

The status of the **PWR_ON** input pin of TOBY-L2 modules while applying the **VCC** module supply is not relevant: during this phase the **PWR_ON** pin can be set high or low by the external circuit.

When the TOBY-L2 modules are in the power-off mode (i.e. switched off with valid **VCC** module supply applied), they can be switched on as following:

- Low level on the **PWR_ON** pin, which is normally set high by an internal pull-up, for a valid time period.
- Low level on the **RESET_N** pin, which is normally set high by an internal pull-up, for a valid time period.
- RTC alarm, i.e. pre-programmed alarm by AT+CALA command (see u-blox AT Commands Manual [3]).

As described in Figure 13, the TOBY-L2 series **PWR_ON** input is equipped with an internal active pull-up resistor to the **VCC** module supply: the **PWR_ON** input voltage thresholds are different from the other generic digital interfaces. Detailed electrical characteristics are described in TOBY-L2 series Data Sheet [1].

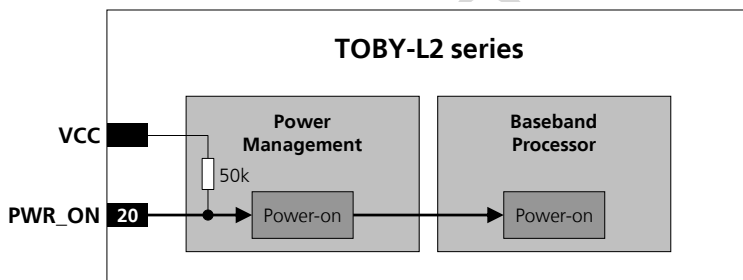

Figure 13: TOBY-L2 series **PWR_ON** input description

Figure 14 shows the module power-on sequence from the not-powered mode, describing the following phases:

- The external supply is applied to the **VCC** or **3.3Vaux** module supply inputs, representing the start-up event.
- The **PWR_ON** and the **RESET_N** or **PERST#** pins suddenly rise to high logic level due to internal pull-ups.
- The **V_BCKP** RTC supply output is suddenly enabled by the module as **VCC** reaches a valid voltage value.
- All the generic digital pins of the module are tri-stated until the switch-on of their supply source (**V_INT**).
- The internal reset signal is held low: the baseband core and all the digital pins are held in the reset state. The reset state of all the digital pins is reported in the pin description table of TOBY-L2 Series Data Sheet [1].
- When the internal reset signal is released, any digital pin is set in a proper sequence from the reset state to the default operational configured state. The duration of this pins' configuration phase differs within generic digital interfaces and the USB interface due to host / device enumeration timings (see section 1.9.1).
- The module is fully ready to operate after all interfaces are configured.

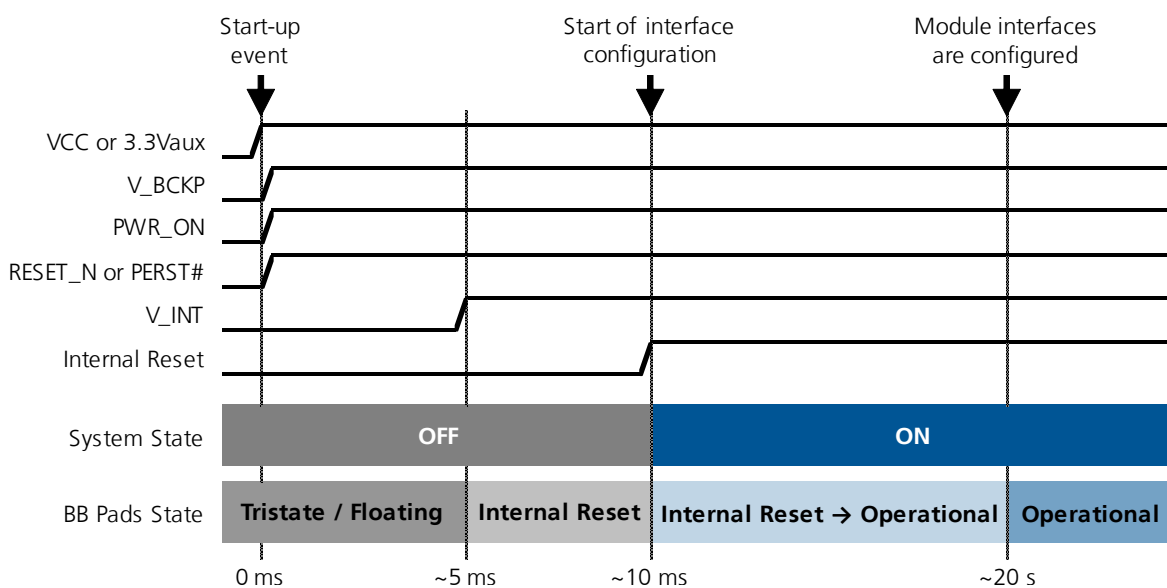

Figure 14: TOBY-L2 and MPC1-L2 series power-on sequence description



The Internal Reset signal is not available on a module pin, but the host application can monitor:

- The **V_INT** pin to sense the start of the TOBY-L2 module power-on sequence.
- The USB interface to sense the start of the MPC1-L2 module power-on sequence: the module, as USB device, informs the host of the attach event via a reply on its status change pipe for proper bus enumeration process according to Universal Serial Bus Revision 2.0 specification [6].



Before the switch-on of the generic digital interface supply source (**V_INT**) of the module, no voltage driven by an external application should be applied to any generic digital interface of TOBY-L2 module.



Before the TOBY-L2 and MPC1-L2 series module is fully ready to operate, the host application processor should not send any AT command over the AT communication interfaces (USB, UART) of the module.

1.6.2 Module power-off

TOBY-L2 series can be properly switched off by:

- AT+CPWROFF command (see u-blox AT Commands Manual [3]). The current parameter settings are saved in the module's non-volatile memory and a proper network detach is performed.



The MPC1-L2 series modules do not switch off by the AT+CPWROFF command as the TOBY-L2 modules, but the AT+CPWROFF command causes a reset (reboot) of the module due to the MPC1-L2 module's internal configuration: the command stores the actual parameter settings in the non-volatile memory of MPC1-L2 modules and performs a network detach, with a subsequent reset (reboot) of the module.

An abrupt under-voltage shutdown occurs on TOBY-L2 and MPC1-L2 series modules when the **VCC** or **3.3Vaux** module supply is removed. If this occurs, it is not possible to perform the storing of the current parameter settings in the module's non-volatile memory or to perform the proper network detach.



It is highly recommended to avoid an abrupt removal of the **VCC** supply during TOBY-L2 modules normal operations: the power off procedure must be started by the AT+CPWROFF command, waiting the command response for a proper time period (see u-blox AT Commands Manual [3]), and then a proper **VCC** supply has to be held at least until the end of the modules' internal power off sequence, which occurs when the generic digital interfaces supply output (**V_INT**) is switched off by the module.



It is highly recommended to avoid an abrupt removal of the **3.3Vaux** supply during MPC1-L2 modules normal operations: the power off procedure must be started by setting the MPC1-L2 module in the halt mode by the AT+CFUN=127 command (which stores the actual parameter settings in the non-volatile memory of the module and performs a network detach), waiting the command response for a proper time period (see the u-blox AT Commands Manual [3]), and then the **3.3Vaux** supply can be removed.

An abrupt hardware shutdown occurs on TOBY-L2 series modules when a low level is applied on the **RESET_N** pin for a specific time period. In this case, the current parameter settings are not saved in the module's non-volatile memory and a proper network detach is not performed.



It is highly recommended to avoid an abrupt hardware shutdown of the module by forcing a low level on the **RESET_N** input pin during module normal operation: the **RESET_N** line should be set low only if reset or shutdown via AT commands fails or if the module does not reply to a specific AT command after a time period longer than the one defined in the u-blox AT Commands Manual [3].

An over-temperature or an under-temperature shutdown occurs on TOBY-L2 and MPC1-L2 series modules when the temperature measured within the cellular module reaches the dangerous area, if the optional Smart Temperature Supervisor feature is enabled and configured by the dedicated AT command. For more details see u-blox AT Commands Manual [3], +USTS AT command.



The Smart Temperature Supervisor feature is not supported by the "00", "01", and "50" product versions.

Figure 15 describes the TOBY-L2 power-off sequence by means of AT+CPWROFF with the following phases:

- When the +CPWROFF AT command is sent, the module starts the switch-off routine.
- The module replies OK on the AT interface: the switch-off routine is in progress.
- At the end of the switch-off routine, all the digital pins are tri-stated and all the internal voltage regulators are turned off, including the generic digital interfaces supply (**V_INT**), except the RTC supply (**V_BCKP**).
- Then, the module remains in power-off mode as long as a switch on event does not occur (e.g. applying a proper low level to the **PWR_ON** input, or applying a proper low level to the **RESET_N** input), and enters not-powered mode if the supply is removed from the **VCC** pins.

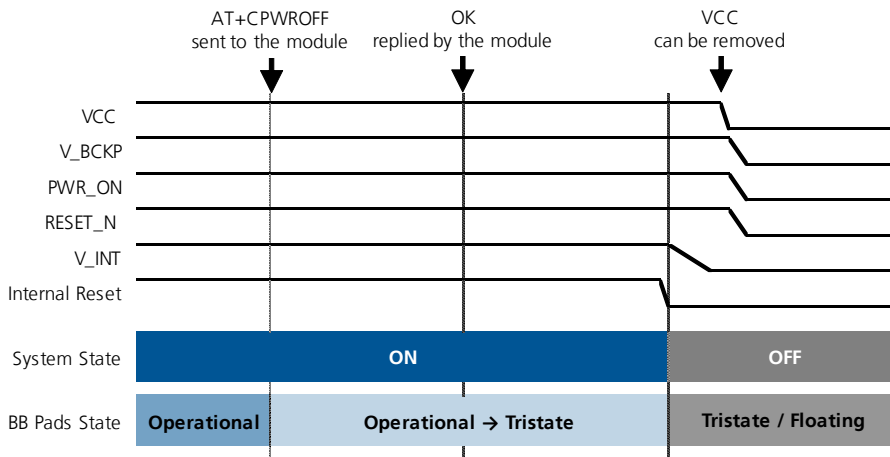

Figure 15: TOBY-L2 series power-off sequence description



The Internal Reset signal is not available on a module pin, but the application can monitor the **V_INT** pin to sense the end of the power-off sequence.

Figure 16 describes the MPC1-L2 power-off procedure with the following phases:

- When the AT+CFUN=127 command is issued, the module starts the halt mode setting routine.
- The module replies OK on the AT interface: after this, the module is set in the halt mode.
- Then, the module remains in the Halt mode and enters not-powered mode if the supply is removed from the **3.3Vaux** pins.

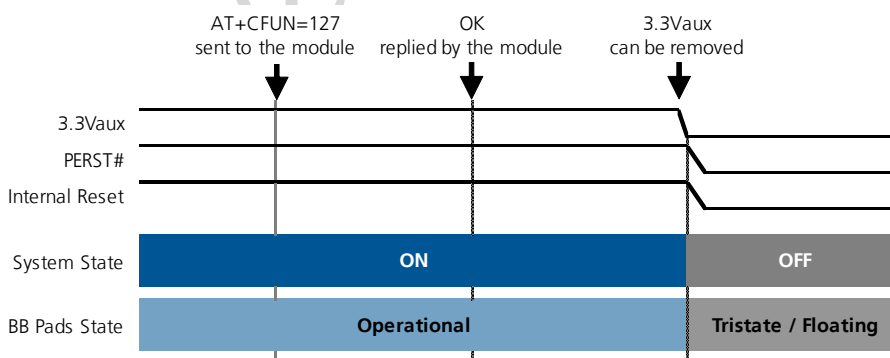

Figure 16: MPC1-L2 series power-off procedure description



The duration of each phase in the TOBY-L2 and MPC1-L2 series modules' switch-off routines can largely vary depending on the application / network settings and the concurrent module activities.

1.6.3 Module reset

TOBY-L2 and MPC1-L2 series modules can be properly reset (rebooted) by:

- AT+CFUN command (see u-blox AT Commands Manual [3]).

MPC1-L2 series modules can be additionally properly reset (rebooted) by:

- AT+CPWROFF command (see u-blox AT Commands Manual [3]): the behavior differs than TOBY-L2 series, as MPC1-L2 modules will reboot rather than remain switched off due to modules' internal configuration.

In the cases listed above an "internal" or "software" reset of the module is executed: the current parameter settings are saved in the module's non-volatile memory and a proper network detach is performed.

An abrupt hardware reset occurs on TOBY-L2 and MPC1-L2 series modules when a low level is applied on the **RESET_N** or **PERST#** input pin for a specific time period. In this case, the current parameter settings are not saved in the module's non-volatile memory and a proper network detach is not performed.



It is highly recommended to avoid an abrupt hardware reset of the module by forcing a low level on the **RESET_N** or **PERST#** input during modules normal operation: the **RESET_N** or **PERST#** line should be set low only if reset or shutdown via AT commands fails or if the module does not provide a reply to a specific AT command after a time period longer than the one defined in the u-blox AT Commands Manual [3].

As described in Figure 17, the **RESET_N** and **PERST#** input pins are equipped with an internal pull-up to the **VCC** supply in the TOBY-L2 series and to the 3.3 V in the MPC1-L2 series.

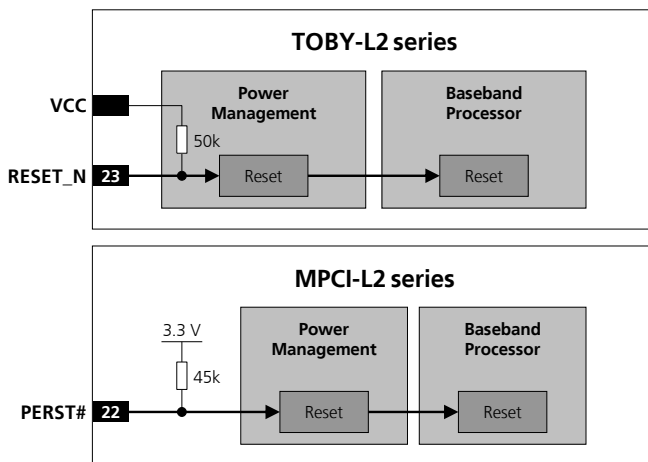

Figure 17: TOBY-L2 and MPC1-L2 series **RESET_N** and **PERST#** input equivalent circuit description



For more electrical characteristics details see TOBY-L2 Data Sheet [1] and MPC1-L2 Data Sheet [2].

1.6.4 Module configuration selection by host processor



The **HOST_SELECT0** and **HOST_SELECT1** pins are not available on MPC1-L2 series modules.



The selection of the module configuration by the host application processor over the **HOST_SELECT0** and **HOST_SELECT1** pins is not supported by TOBY-L2 "00", "01", and "50" product versions.

TOBY-L2 series modules include two input pins (**HOST_SELECT0** and **HOST_SELECT1**) for the selection of the module configuration by the host application processor.

1.7 Antenna interface

1.7.1 Antenna RF interfaces (ANT1 / ANT2)

TOBY-L2 and MPC1-L2 series modules provide two RF interfaces for connecting the external antennas:

- The **ANT1** represents the primary RF input/output for transmission and reception of LTE/3G/2G RF signals.

The **ANT1** pin of TOBY-L2 series modules has a nominal characteristic impedance of $50\ \Omega$ and must be connected to the primary Tx / Rx antenna through a $50\ \Omega$ transmission line to allow proper RF transmission and reception.

The **ANT1** Hirose U.FL-R-SMT coaxial connector receptacle of MPC1-L2 series modules has a nominal characteristic impedance of $50\ \Omega$ and must be connected to the primary Tx / Rx antenna through a mated RF plug with a $50\ \Omega$ coaxial cable assembly to allow proper RF transmission and reception.
- The **ANT2** represents the secondary RF input for the reception of the LTE RF signals for the Down-Link MIMO 2 x 2 radio technology supported by TOBY-L2 and MPC1-L2 series modules as required feature for LTE category 4 UEs, and for the reception of the 3G RF signals for the Down-Link Rx diversity radio technology supported by TOBY-L2 and MPC1-L2 series modules as additional feature for 3G DC-HSDPA category 24 UEs.

The **ANT2** pin of TOBY-L2 series modules has a nominal characteristic impedance of $50\ \Omega$ and must be connected to the secondary Rx antenna through a $50\ \Omega$ transmission line to allow proper RF reception.

The **ANT2** Hirose U.FL-R-SMT coaxial connector receptacle of MPC1-L2 series modules has a nominal characteristic impedance of $50\ \Omega$ and must be connected to the secondary Rx antenna through a mated RF plug with a $50\ \Omega$ coaxial cable assembly to allow proper RF reception.

The Multiple Input Multiple Output (MIMO) radio technology is an essential component of LTE radio systems based on the use of multiple antennas at both the transmitter and receiver sides to improve communication performance and achieve highest possible bit rate. A MIMO $m \times n$ system consists of m transmit and n receive antennas, where the data to be transmitted is divided into m independent data streams. Note that the terms Input and Output refer to the radio channel carrying the signal, not to the devices having antennas, so that in the Down-Link MIMO 2 x 2 system supported by TOBY-L2 and MPC1-L2 series modules:

- The LTE data stream is divided into 2 independent streams by the Tx-antennas of the base station
- The cellular modules, at the receiver side, receives both LTE data streams by 2 Rx-antennas (**ANT1 / ANT2**)

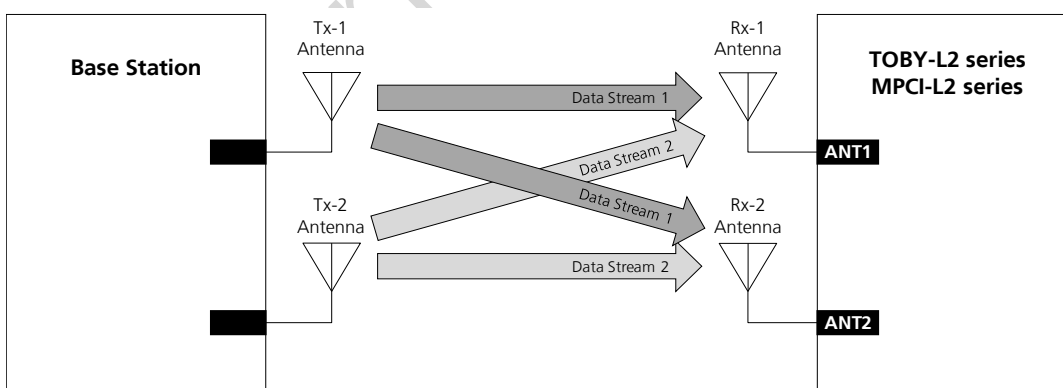

Figure 18: Description of the LTE Down-Link MIMO 2 x 2 radio technology supported by TOBY-L2 and MPC1-L2 series modules

TOBY-L2 and MPC1-L2 series modules support the LTE MIMO 2 x 2 radio technology in the Down-Link path only (from the base station to the module): the **ANT1** port is the only one RF interface that is used by the module to transmit the RF signal in the Up-Link path (from the module to the base station).

1.7.1.1 Antenna RF interfaces requirements

Table 8, Table 9 and Table 10 summarize the requirements for the antennas RF interfaces (**ANT1** / **ANT2**). See section 2.4.1 for suggestions to properly design antennas circuits compliant with these requirements.

 **The antenna circuits affect the RF compliance of the device integrating TOBY-L2 and MPC1-L2 series modules with applicable required certification schemes (for more details see section 4). Compliance is guaranteed if the antenna RF interfaces (**ANT1** / **ANT2**) requirements summarized in Table 8, Table 9 and Table 10 are fulfilled.**

Item	Requirements	Remarks
Impedance	50 Ω nominal characteristic impedance	The impedance of the antenna RF connection must match the 50 Ω impedance of the ANT1 port.
Frequency Range	See the TOBY-L2 series Data Sheet [1] and the MPC1-L2 series Data Sheet [2]	The required frequency range of the antenna connected to ANT1 port depends on the operating bands of the used cellular module and the used mobile network.
Return Loss	$S_{11} < -10$ dB (VSWR < 2:1) recommended $S_{11} < -6$ dB (VSWR < 3:1) acceptable	The Return loss or the S_{11} , as the VSWR, refers to the amount of reflected power, measuring how well the primary antenna RF connection matches the 50 Ω characteristic impedance of the ANT1 port. The impedance of the antenna termination must match as much as possible the 50 Ω nominal impedance of the ANT1 port over the operating frequency range, reducing as much as possible the amount of reflected power.
Efficiency	> -1.5 dB (> 70%) recommended > -3.0 dB (> 50%) acceptable	The radiation efficiency is the ratio of the radiated power to the power delivered to antenna input: the efficiency is a measure of how well an antenna receives or transmits. The radiation efficiency of the antenna connected to the ANT1 port needs to be enough high over the operating frequency range to comply with the Over-The-Air (OTA) radiated performance requirements, as Total Radiated Power (TRP) and the Total Isotropic Sensitivity (TIS), specified by applicable related certification schemes.
Maximum Gain	According to radiation exposure limits	The power gain of an antenna is the radiation efficiency multiplied by the directivity: the gain describes how much power is transmitted in the direction of peak radiation to that of an isotropic source. The maximum gain of the antenna connected to ANT1 port must not exceed the herein stated value to comply with regulatory agencies radiation exposure limits. For additional info see the section 4.2.2.
Input Power	> 33 dBm (> 2 W)	The antenna connected to the ANT1 port must support with adequate margin the maximum power transmitted by the modules.

Table 8: Summary of primary Tx/Rx antenna RF interface (ANT1**) requirements**

Item	Requirements	Remarks
Impedance	50 Ω nominal characteristic impedance	The impedance of the antenna RF connection must match the 50 Ω impedance of the ANT2 port.
Frequency Range	See the TOBY-L2 series Data Sheet [1] and the MPC1-L2 series Data Sheet [2]	The required frequency range of the antennas connected to ANT2 port depends on the operating bands of the used cellular module and the used Mobile Network.
Return Loss	$S_{11} < -10$ dB (VSWR < 2:1) recommended $S_{11} < -6$ dB (VSWR < 3:1) acceptable	The Return loss or the S_{11} , as the VSWR, refers to the amount of reflected power, measuring how well the secondary antenna RF connection matches the 50 Ω characteristic impedance of the ANT2 port. The impedance of the antenna termination must match as much as possible the 50 Ω nominal impedance of the ANT2 port over the operating frequency range, reducing as much as possible the amount of reflected power.
Efficiency	> -1.5 dB (> 70%) recommended > -3.0 dB (> 50%) acceptable	The radiation efficiency is the ratio of the radiated power to the power delivered to antenna input: the efficiency is a measure of how well an antenna receives or transmits. The radiation efficiency of the antenna connected to the ANT2 port needs to be enough high over the operating frequency range to comply with the Over-The-Air (OTA) radiated performance requirements, as the TIS, specified by applicable related certification schemes.

Table 9: Summary of secondary Rx antenna RF interface (ANT2) requirements

Item	Requirements	Remarks
Efficiency imbalance	< 0.5 dB recommended < 1.0 dB acceptable	The radiation efficiency imbalance is the ratio of the primary (ANT1) antenna efficiency to the secondary (ANT2) antenna efficiency: the efficiency imbalance is a measure of how much better an antenna receives or transmits compared to the other antenna. The radiation efficiency of the secondary antenna needs to be roughly the same of the radiation efficiency of the primary antenna for good RF performance.
Envelope Correlation Coefficient	< 0.4 recommended < 0.5 acceptable	The Envelope Correlation Coefficient (ECC) between the primary (ANT1) and the secondary (ANT2) antenna is an indicator of 3D radiation pattern similarity between the two antennas: low ECC results from antenna patterns with radiation lobes in different directions. The ECC between primary and secondary antenna needs to be enough low to comply with radiated performance requirements specified by related certification schemes.
Isolation	> 15 dB recommended > 10 dB acceptable	The antenna to antenna isolation is the loss between the primary (ANT1) and the secondary (ANT2) antenna: high isolation results from low coupled antennas. The isolation between primary and secondary antenna needs to be high for good RF performance.

Table 10: Summary of primary (ANT1) and secondary (ANT2) antennas relationship requirements

1.7.2 Antenna detection interface (ANT_DET)



Antenna detection (**ANT_DET**) is not available on MPC1-L2 series modules.



Antenna detection (**ANT_DET**) is not supported by TOBY-L2 "00", "01", and "50" product versions.

The antenna detection is based on ADC measurement. The **ANT_DET** pin is an Analog to Digital Converter (ADC) provided to sense the antenna presence.

The antenna detection function provided by **ANT_DET** pin is an optional feature that can be implemented if the application requires it. The antenna detection is forced by the +UANTR AT command. See the u-blox AT Commands Manual [3] for more details on this feature.

The **ANT_DET** pin generates a DC current (for detailed characteristics see the TOBY-L2 series Data Sheet [1]) and measures the resulting DC voltage, thus determining the resistance from the antenna connector provided on the application board to GND. So, the requirements to achieve antenna detection functionality are the following:

- an RF antenna assembly with a built-in resistor (diagnostic circuit) must be used
- an antenna detection circuit must be implemented on the application board

See section 2.4.2 for antenna detection circuit on application board and diagnostic circuit on antenna assembly design-in guidelines.

1.8 SIM interface

1.8.1 SIM interface

TOBY-L2 and MPC1-L2 series modules provide high-speed SIM/ME interface including automatic detection and configuration of the voltage required by the connected SIM card or chip.

Both 1.8 V and 3 V SIM types are supported. Activation and deactivation with automatic voltage switch from 1.8 V to 3 V are implemented, according to ISO-IEC 7816-3 specifications. The **VSIM** or **UIM_PWR** supply output provides internal short circuit protection to limit start-up current and protect the SIM to short circuits.

The SIM driver supports the PPS (Protocol and Parameter Selection) procedure for baud-rate selection, according to the values determined by the SIM card or chip.

1.8.2 SIM detection interface



SIM detection (**GPIO5**) is not available on MPC1-L2 series modules.



SIM detection (**GPIO5**) is not supported by TOBY-L2 "00", "01", and "50" product versions.

The **GPIO5** pin is by default configured to detect the SIM card mechanical / physical presence. The pin is configured as input with an internal active pull-down enabled, and it can sense SIM card presence only if properly connected to the mechanical switch of a SIM card holder as described in section 2.5:

- Low logic level at **GPIO5** input pin is recognized as SIM card not present
- High logic level at **GPIO5** input pin is recognized as SIM card present

The SIM card detection function provided by **GPIO5** pin is an optional feature that can be implemented / used or not according to the application requirements: an Unsolicited Result Code (URC) is generated each time that there is a change of status (for more details see the u-blox AT Commands Manual [3]).

The optional function "SIM card hot insertion/removal" can be additionally enabled on the **GPIO5** pin by specific AT command (see the u-blox AT Commands Manual [3]).

1.9 Data communication interfaces

TOBY-L2 and MPC1-L2 series modules provide the following serial communication interface:

- USB interface: High-Speed USB 2.0 compliant interface available for the communication with an external host application processor, for AT commands, data communication, FW upgrade by means of the FOAT feature, FW upgrade by means of the u-blox EasyFlash tool and for diagnostic purpose (see section 1.9.1 for functional description)

TOBY-L2 series modules additionally provide the following serial communication interfaces:

- UART interface: asynchronous serial interface available for the communication with an external host application processor, for AT commands, data communication, FW upgrade by means of the FOAT feature (see section 1.9.2 for functional description)
- DDC interface: I²C bus compatible interface available for the communication with u-blox GNSS positioning chips/modules and with external I²C devices as an audio codec (see section 1.9.3 for functional description)
- SDIO interface: Secure Digital Input Output interface available for the communication with an external Wi-Fi chip or module (see section 1.9.4 for functional description)

1.9.1 Universal Serial Bus (USB)

1.9.1.1 USB features

TOBY-L2 and MPC1-L2 series modules include a High-Speed USB 2.0 compliant interface with maximum data rate of 480 Mb/s, representing the main interface for transferring high speed data with a host application processor: the USB interface is available for AT commands, data communication, FW upgrade by means of the FOAT feature, FW upgrade by means of the u-blox EasyFlash tool and for diagnostic purpose.

The module itself acts as a USB device and can be connected to a USB host such as a Personal Computer or an embedded application microprocessor equipped with compatible drivers.

The **USB_D+** / **USB_D-** lines carry the USB serial bus data and signaling, providing all the functionalities for the bus attachment, configuration, enumeration, suspension or remote wakeup according to the Universal Serial Bus Revision 2.0 specification [6]

The additional **VUSB_DET** input is available as an optional feature to sense the host VBUS voltage (5.0 V typical).

 The **VUSB_DET** functionality is not supported by TOBY-L2 "00", "01", and "50" product versions: the pin should be left unconnected or it should not be driven high by any external device, because a high logic level applied to the pin will represent a module switch-on event (additional to the ones listed in section 1.6.1) and will prevent reaching the minimum possible consumption with power saving enabled.

 The **VUSB_DET** pin is not available on MPC1-L2 series modules.

The USB interface is controlled and operated with:

- AT commands according to 3GPP TS 27.007 [8], 3GPP TS 27.005 [9], 3GPP TS 27.010 [10]
- u-blox AT commands

 For the complete list of supported AT commands and their syntax see u-blox AT Commands Manual [3].

TOBY-L2 and MPC1-L2 modules provide by default the following USB profile with the listed set of USB functions:

- 1 RNDIS for Ethernet-over-USB connection
- 1 CDC-ACM for AT commands and data communication

The USB profile of TOBY-L2 and MPC1-L2 modules identifies itself by its VID (Vendor ID) and PID (Product ID) combination, included in the USB device descriptor according to the USB 2.0 specifications [6].

The VID and PID of the default USB profile configuration with the set of functions described above (1 RNDIS for Ethernet-over-USB and 1 CDC-ACM for AT commands and data) are the following:

- VID = 0x1546
- PID = 0x1146

Figure 19 summarizes the USB end-points available with the default USB profile configuration.

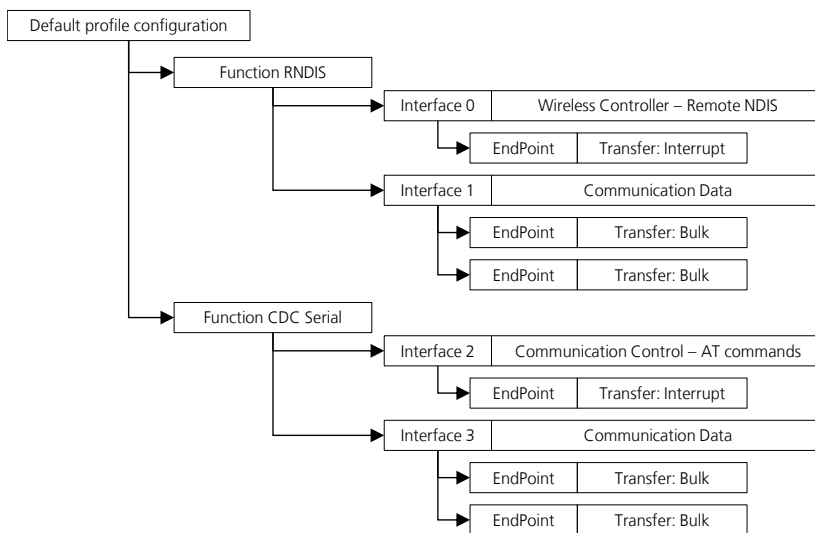

Figure 19: TOBY-L2 and MPC1-L2 series USB End-Points summary for the default USB profile configuration

The USB of the modules can be configured by the AT+UUSBCONF command (for more details see the u-blox AT Commands Manual [3]) to select different sets of USB functions available in mutually exclusive way, selecting the active USB profile consisting of a specific set of functions with various capabilities and purposes, such as:

- CDC-ACM for AT commands and data
- CDC-ACM for GNSS tunneling
- CDC-ACM for SIM Access Profile (SAP)
- CDC-ACM for diagnostic
- RNDIS for Ethernet-over-USB
- CDC-ECM for Ethernet-over-USB
- CDC-NCM for Ethernet-over-USB
- MBIM for Ethernet-over-USB



CDC-ACM for GNSS tunneling, CDC-ACM for SIM Access Profile (SAP), and CDC-NCM and MBIM functions are not supported by TOBY-L2 "00", "01", and "50" product versions.

For example, the default USB profile configuration which provides 2 functions (1 RNDIS for Ethernet-over-USB and 1 CDC-ACM for AT commands and data) can be changed by means of the AT+UUSBCONF command switching to a USB profile configuration which provides the following 6 functions:

- 3 CDC-ACM for AT commands and data
- 1 CDC-ACM for GNSS tunneling
- 1 CDC-ACM for SIM Access Profile (SAP)
- 1 CDC-ACM for diagnostic

As each USB profile of TOBY-L2 and MPC1-L2 modules identifies itself by its specific VID and PID combination included in the USB device descriptor according to the USB 2.0 specifications [6], the VID and PID combination changes as following by switching the active USB profile configuration to the set of 6 functions described above:

- VID = 0x1546
- PID = 0x1141

Alternatively, as another example, the USB profile configuration can be changed by means of the AT+UUSBCONF command switching to a USB profile configuration which provides the following 4 functions:

- 1 CDC-ECM for Ethernet-over-USB
- 3 CDC-ACM for AT commands and data

In case of this USB profile with the set of 4 functions described above, the VID and PID are the following:

- VID = 0x1546
- PID = 0x1143

The switch of the active USB profile selected by the AT+UUSBCONF command is not performed immediately. The settings are saved in the non-volatile memory of the module at the power off, and the new configuration is effective at the subsequent reboot of the module.

If the USB is connected to the host before the module is switched on, or if the module is reset (rebooted) with the USB connected to the host, the VID and PID are automatically updated during the boot of the module. First, VID and PID are the following:

- VID = 0x1546
- PID = 0x1140

This VID and PID combination identifies a USB profile where no USB function described above is available: AT commands must not be sent to the module over the USB profile identified by this VID and PID combination.

Then, after a time period (roughly 20 s, depending on the host / device enumeration timings), the VID and PID are updated to the ones related to the USB profile selected by the AT+UUSBCONF command.



For more details regarding the TOBY-L2 and MPC1-L2 series modules USB configurations and capabilities, see the u-blox AT Commands Manual [3], +UUSBCONF AT command.

1.9.1.2 USB in Windows

The USB drivers (INF files) are provided for Windows systems and should be installed properly by following the step-by-step instruction in EVK-L20 / EVK-L21 User Guide [4].

USB drivers are available for the following operating system platforms:

- Windows Vista
- Windows 7
- Windows 8
- Windows 8.1
- Windows Embedded Compact 7

The module firmware can be upgraded over the USB interface by means of the FOAT feature, or using the u-blox EasyFlash tool (for more details see Firmware Update Application Note [4]).

1.9.1.3 USB in Linux/Android

It is not required to install a specific driver for each Linux-based or Android-based operating system (OS) to use the module USB interface, which is compatible with standard Linux/Android USB kernel drivers.

The full capability and configuration of the module USB interface can be reported by running “lsusb -v” or an equivalent command available in the host operating system when the module is connected.

1.9.1.4 USB and power saving

The modules automatically enter the USB suspended state when the device has observed no bus traffic for a specific time period according to the USB 2.0 specification [6]. In suspended state, the module maintains any USB internal status as device. In addition, the module enters the suspended state when the hub port it is attached to is disabled. This is referred to as USB selective suspend.



If the USB is suspended and a power saving configuration is enabled by the AT+UPSV command, the module automatically enters the low power idle-mode whenever possible but it wakes up to active-mode according to any required activity related to the network (e.g. the periodic paging reception described in section 1.5.1.5) or any other required activity related to the functions / interfaces of the module.

The USB exits suspend mode when there is bus activity. If the USB is connected and not suspended, the module is forced to stay in active-mode, therefore the AT+UPSV settings are overruled but they have effect on the power saving configuration of the other interfaces.

The modules are capable of USB remote wake-up signaling: i.e. it may request the host to exit suspend mode or selective suspend by using electrical signaling to indicate remote wake-up, for example due to incoming call, URCs, data reception on a socket. The remote wake-up signaling notifies the host that it should resume from its suspended mode, if necessary, and service the external event. Remote wake-up is accomplished using electrical signaling described in the USB 2.0 specifications [6].

For the module current consumption description with power saving enabled and USB suspended, or with power saving disabled and USB not suspended, see the sections 1.5.1.5, 1.5.1.6 and the TOBY-L2 Data Sheet [1] or the MPC1-L2 Data Sheet [2].

1.9.2 Asynchronous serial interface (UART)

-  The UART interface is not available on MPC1-L2 series modules.
-  The UART interface is not supported by TOBY-L200-00S and TOBY-L210-00S modules versions.
-  The **DTR**, **DSR** and **DCD** signals are not supported by TOBY-L200-50S, TOBY-L210-50S modules versions.

1.9.2.1 UART features

The UART interface is a 9-wire 1.8 V unbalanced asynchronous serial interface (UART) that can be connected to an application host processor for AT commands and data communication.

The module firmware can be upgraded over the UART interface by means of the Firmware upgrade over AT (FOAT) feature only: for more details see section 1.15 and Firmware update application note [4].

UART interface provides RS-232 functionality conforming to the ITU-T V.24 Recommendation [7], with CMOS compatible signal levels: 0 V for low data bit or ON state, and 1.8 V for high data bit or OFF state (for detailed electrical characteristics see TOBY-L2 Data Sheet [1]), providing:

- data lines (**RXD** as output, **TXD** as input),
- hardware flow control lines (**CTS** as output, **RTS** as input),
- modem status and control lines (**DTR** as input, **DSR** as output, **DCD** as output, **RI** as output).

TOBY-L2 modules are designed to operate as LTE/3G/2G cellular modems, i.e. as the data circuit-terminating equipment (DCE) according to the ITU-T V.24 Recommendation [7]. A host application processor connected to the module through the UART interface represents the data terminal equipment (DTE).



-  UART signal names of TOBY-L2 modules conform to the ITU-T V.24 Recommendation [7]: e.g. **TXD** line represents data transmitted by the DTE (host processor output) and received by the DCE (module input).

The UART interface is controlled and operated with:



- AT commands according to 3GPP TS 27.007 [8], 3GPP TS 27.005 [9], 3GPP TS 27.010 [10]
- u-blox AT commands

-  For the complete list of supported AT commands and their syntax see u-blox AT Commands Manual [3], and in particular for the UART configuration see the +IPR, +ICF, +IFC, &K, \Q, +UPSV AT commands.

Flow control handshakes are supported by the UART interface and can be set by appropriate AT commands (see u-blox AT Commands Manual [3], &K, +IFC, \Q AT commands): hardware flow control (over the **RTS** / **CTS** lines), software flow control (XON/XOFF), or none flow control.

-  Hardware flow control is enabled by default.
-  Software flow control is not supported by "00", "01" and "50" module product versions.

The one-shot autobauding is supported: the automatic baud rate detection is performed only once, at module start up. After the detection, the module works at the detected baud rate and the baud rate can only be changed by AT command (see u-blox AT Commands Manual [3], +IPR).

-  One-shot automatic baud rate recognition (autobauding) is enabled by default.
-  The automatic baud rate recognition (autobauding) is not supported by "50" product version.

The following baud rates can be configured by AT command (see u-blox AT Commands Manual [3], +IPR):

- 9600 b/s
- 19200 b/s
- 38400 b/s
- 57600 b/s
- 115200 b/s, default value for "50" modules product version or when one-shot autobauding is disabled
- 230400 b/s
- 460800 b/s
- 921600 b/s

The following frame formats can be configured by AT command (see u-blox AT Commands Manual [3], +ICF):

- 8N2 (8 data bits, no parity, 2 stop bits)
- 8N1 (8 data bits, no parity, 1 stop bit), default frame format
- 8E1 (8 data bits, even parity, 1 stop bit)
- 8O1 (8 data bits, odd parity, 1 stop bit)
- 7N2 (7 data bits, no parity, 2 stop bits)
- 7N1 (7 data bits, no parity, 1 stop bit)
- 7E1 (7 data bits, even parity, 1 stop bit)
- 7O1 (7 data bits, odd parity, 1 stop bit)



Automatic frame format recognition is not supported by "00", "01" and "50" module product versions.

Figure 20 describes the 8N1 frame format, which is the default frame format configuration.

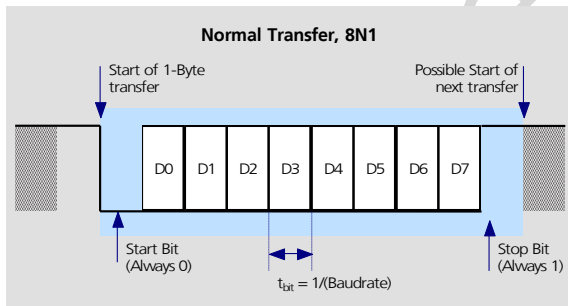

Figure 20: Description of UART default frame format (8N1, i.e. 8 data bits, no parity, 1 stop bit)

1.9.2.2 UART interface configuration

The UART interface of TOBY-L2 series modules is available as AT command interface with the default configuration described in Table 11 (for more details and information about further settings, see the u-blox AT Commands Manual [3]).

Interface	AT Settings	Comments
UART interface	AT interface: enabled	AT command interface is enabled by default on the UART physical interface
	AT+IPR=0 AT+IPR=115200	One-shot autobauding enabled by default on the modules, except "50" product version. 115200 b/s baud rate enabled by default on "50" modules product version.
	AT+ICF=3,1	8N1 frame format enabled by default
	AT&K3	HW flow control enabled by default
	AT&S1	DSR line (Circuit 107 in ITU-T V.24) set ON in data mode ⁴ and set OFF in command mode ⁷
	AT&D1	Upon an ON-to-OFF transition of DTR line (Circuit 108/2 in ITU-T V.24), the module (DCE) enters online command mode ⁷ and issues an OK result code
	AT&C1	DCD line (Circuit 109 in ITU-T V.24) changes in accordance with the Carrier detect status; ON if the Carrier is detected, OFF otherwise
	MUX protocol: disabled	Multiplexing mode is disabled by default and it can be enabled by AT+CMUX command. For more details, see the Mux Implementation Application Note [11]. The following virtual channels are defined: <ul style="list-style-type: none"> • Channel 0: Control channel • Channel 1 – 5: AT commands / data connection • Channel 6: GNSS tunneling (not supported by "00", "01", "50" product versions) • Channel 7: SIM Access Profile (not supported by "00", "01", "50" product versions)

Table 11: Default UART interface configuration

1.9.2.3 UART signals behavior

At the module switch-on, before the UART interface initialization (as described in the power-on sequence reported in Figure 14), each pin is first tri-stated and then is set to its relative internal reset state⁵. At the end of the boot sequence, the UART interface is initialized, the module is by default in active-mode, and the UART interface is enabled as AT commands interface.

The configuration and the behavior of the UART signals after the boot sequence are described below. See section 1.4 for definition and description of module operating modes referred to in this section.

RXD signal behavior

The module data output line (**RXD**) is set by default to the OFF state (high level) at UART initialization. The module holds **RXD** in the OFF state until the module does not transmit some data.

TXD signal behavior

The module data input line (**TXD**) is set by default to the OFF state (high level) at UART initialization. The **TXD** line is then held by the module in the OFF state if the line is not activated by the DTE: an active pull-up is enabled inside the module on the **TXD** input.

⁴ For the definition of the interface data mode, command mode and online command mode see the u-blox AT Commands Manual [3]

⁵ See the pin description table in the TOBY-L2 series Data Sheet [1]

CTS signal behavior

The module hardware flow control output (**CTS** line) is set to the ON state (low level) at UART initialization.

If the hardware flow control is enabled, as it is by default, the **CTS** line indicates when the UART interface is enabled (data can be sent and received). The module drives the **CTS** line to the ON state or to the OFF state when it is either able or not able to accept data from the DTE over the UART interface (for more details see section 1.9.2.4 and in particular Figure 22).



If hardware flow control is enabled, then when the **CTS** line is OFF it does not necessarily mean that the module is in low power idle-mode, but only that the UART is not enabled, as the module could be forced to stay in active-mode for other activities, e.g. related to the network or related to other interfaces.



If hardware flow control is enabled and the multiplexer protocol is active, then the **CTS** line state is mapped to FCon / FCOFF MUX command for flow control matters outside the power saving configuration while the physical **CTS** line is still used as a UART power state indicator. For more details, see the Mux Implementation Application Note [11].

The **CTS** hardware flow control setting can be changed by AT commands (for more details, see the u-blox AT Commands Manual [3], AT&K, ATQ, AT+IFC AT commands).

If the hardware flow control is not enabled, the **CTS** line still indicates when the UART interface is enabled, as it does when hardware flow control is enabled. The module drives the **CTS** line to the ON state or to the OFF state when it is either able or not able to accept data from the DTE over the UART interface, as described in Figure 22.



When the power saving configuration is enabled by AT+UPSV command and the hardware flow-control is not implemented in the DTE/DCE connection, data sent by the DTE can be lost: the first character sent when the module is in low power idle-mode will not be a valid communication character (see section 1.9.2.4 and in particular the sub-section "Wake up via data reception" for further details).

RTS signal behavior

The hardware flow control input (**RTS** line) is set by default to the OFF state (high level) at UART initialization. The module then holds the **RTS** line in the OFF state if the line is not activated by the DTE: an active pull-up is enabled inside the module on the **RTS** input.

If the HW flow control is enabled, as it is by default, the module monitors the **RTS** line to detect permission from the DTE to send data to the DTE itself. If the **RTS** line is set to the OFF state, any on-going data transmission from the module is interrupted until the **RTS** line changes to the ON state.



The DTE must still be able to accept a certain number of characters after the **RTS** line is set to the OFF state: the module guarantees the transmission interruption within two characters from **RTS** state change.

The module behavior according to the **RTS** hardware flow control status can be configured by AT commands (for more details, see the u-blox AT Commands Manual [3], AT&K, ATQ, AT+IFC AT commands).

If AT+UPSV=2 is set and HW flow control is disabled, the module monitors the **RTS** line to manage the power saving configuration (for more details, see section 1.9.2.4 and u-blox AT Commands Manual [3], AT+UPSV):

- When an OFF-to-ON transition occurs on the **RTS** input, the UART is enabled and the module is forced to active-mode; after ~5 ms from the transition the switch is completed and data can be received without loss. The module cannot enter low power idle-mode and the UART is kept enabled as long as the **RTS** input line is held in the ON state
- If the **RTS** input line is set to the OFF state by the DTE, the UART is disabled (held in low power mode) and the module automatically enters low power idle-mode whenever possible

DSR signal behavior

If AT&S1 is set, as it is by default, the **DSR** module output line is set by default to the OFF state (high level) at UART initialization. The **DSR** line is then set to the OFF state when the module is in command mode⁶ or in online command mode⁶ and is set to the ON state when the module is in data mode⁶.

If AT&S0 is set, the **DSR** module output line is set by default to the ON state (low level) at UART initialization and is then always held in the ON state.

DTR signal behavior

The **DTR** module input line is set by default to the OFF state (high level) at UART initialization. The module then holds the **DTR** line in the OFF state if the line is not activated by the DTE: an active pull-up is enabled inside the module on the **DTR** input.

Module behavior according to **DTR** status can be changed by AT command configuration (for more details see the u-blox AT Commands Manual [3], &D AT command description).

If AT+UPSV=3 is set, the **DTR** line is monitored by the module to manage the power saving configuration (for more details, see section 1.9.2.4 and u-blox AT Commands Manual [3], AT+UPSV):

- When an OFF-to-ON transition occurs on the **DTR** input, the UART is enabled and the module is forced to active-mode; after ~5 ms from the transition, the switch is completed and data can be received without loss. The module cannot enter low power idle-mode and the UART is kept enabled as long as the **DTR** input line is held in the ON state
- If the **DTR** input line is set to the OFF state by the DTE, the UART is disabled (held in low power mode) and the module automatically enters low power idle-mode whenever possible

DCD signal behavior

If AT&C1 is set, as it is by default, the **DCD** module output line is set by default to the OFF state (high level) at UART initialization. The module then sets the **DCD** line according to the carrier detect status: ON if the carrier is detected, OFF otherwise.

If a Packet Switched Data call occurs before activating the PPP protocol (data mode), a dial-up application must provide the ATD*99***<context_number># to the module: with this command the module switches from command mode⁶ to data mode⁶ and can accept PPP packets. The module sets the **DCD** line to the ON state, then answers with a CONNECT to confirm the ATD*99 command. The **DCD** ON is not related to the context activation but with the data mode.



The **DCD** is set to ON during the execution of the +CMGS, +CMGW, +USOWR, +USODL AT commands requiring input data from the DTE: the **DCD** line is set to the ON state as soon as the switch to binary/text input mode is completed and the prompt is issued; **DCD** line is set to OFF as soon as the input mode is interrupted or completed (for more details see the u-blox AT Commands Manual [3]).



The **DCD** line is kept in the ON state, even during the online command mode⁶, to indicate that the data call is still established even if suspended, while if the module enters command mode⁶, the **DSR** line is set to the OFF state. For more details see **DSR** signal behavior description.



For scenarios when the **DCD** line setting is requested for different reasons (e.g. SMS texting during online command mode⁶), the **DCD** line changes to guarantee the correct behavior for all the scenarios. For example, in case of SMS texting in online command mode⁶, if the data call is released, **DCD** is kept ON till the SMS command execution is completed (even if the data call release would request **DCD** set OFF).

If AT&C0 is set, the **DCD** module output line is set by default to the ON state (low level) at UART initialization and is then always held in the ON state.

⁶ For the definition of the interface data mode, command mode and online command mode see the u-blox AT Commands Manual [3]

RI signal behavior

The **RI** module output line is set by default to the OFF state (high level) at UART initialization.

The **RI** output line can notify an SMS arrival. When the SMS arrives, the **RI** line switches from OFF to ON for 1 s (see Figure 21), if the feature is enabled by the proper AT command (see the u-blox AT Commands Manual [3], AT+CNMI command).

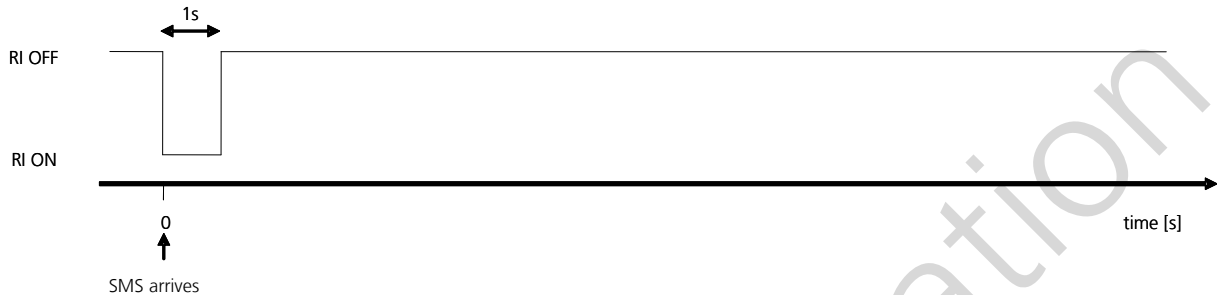

Figure 21: RI behavior at SMS arrival

This behavior allows the DTE to stay in power saving mode until the DCE related event requests service.

For SMS arrival, if several events coincidentally occur or in quick succession each event independently triggers the **RI** line, although the line will not be deactivated between each event. As a result, the **RI** line may stay to ON for more than 1 s, so that:



RI line monitoring cannot be used by the DTE to determine the number of received SMSes.



For multiple events, the **RI** line cannot be used to discriminate the two events, but the DTE must rely on the subsequent URCs and interrogate the DCE with the proper commands.

1.9.2.4 UART and power-saving

The power saving configuration is controlled by the AT+UPSV command (for the complete description, see the u-blox AT Commands Manual [3]). When power saving is enabled, the module automatically enters low power idle-mode whenever possible, and otherwise the active-mode is maintained by the module (see section 1.4 for definition and description of module operating modes referred to in this section).

The AT+UPSV command configures both the module power saving and also the UART behavior in relation to the power saving. The conditions for the module entering low power idle-mode also depend on the UART power saving configuration, as the module does not enter the low power idle-mode according to any required activity related to the network (within or outside an active call) or any other required concurrent activity related to the functions and interfaces of the module, including the UART interface.

The AT+UPSV command can set these different power saving configurations:

- AT+UPSV=0, power saving disabled (default configuration)
- AT+UPSV=1, power saving enabled cyclically
- AT+UPSV=2, power saving enabled and controlled by the UART **RTS** input line
- AT+UPSV=3, power saving enabled and controlled by the UART **DTR** input line

The different power saving configurations that can be set by the +UPSV AT command are described in details in the following subsections. Table 12 summarizes the UART interface communication process in the different power saving configurations, in relation with the hardware flow control settings and the **RTS** input line status. For more details on the +UPSV AT command description, see u-blox AT commands Manual [3].

AT+UPSV	HW flow control	RTS line	DTR line	Communication during idle-mode and wake up
0	Enabled (AT&K3)	ON	ON or OFF	Data sent by the DTE is correctly received by the module. Data sent by the module is correctly received by the DTE.
0	Enabled (AT&K3)	OFF	ON or OFF	Data sent by the DTE is correctly received by the module. Data sent by the module is buffered by the module and will be correctly received by the DTE when it is ready to receive data (i.e. RTS line will be ON).
0	Disabled (AT&K0)	ON or OFF	ON or OFF	Data sent by the DTE is correctly received by the module. Data sent by the module is correctly received by the DTE if it is ready to receive data, otherwise the data is lost.
1	Enabled (AT&K3)	ON	ON or OFF	Data sent by the DTE is buffered by the DTE and will be correctly received by the module when it is ready to receive data (when the UART is enabled). Data sent by the module is correctly received by the DTE.
1	Enabled (AT&K3)	OFF	ON or OFF	Data sent by the DTE is buffered by the DTE and will be correctly received by the module when it is ready to receive data (when the UART is enabled). Data sent by the module is buffered by the module and will be correctly received by the DTE when it is ready to receive data (i.e. RTS line will be ON).
1	Disabled (AT&K0)	ON or OFF	ON or OFF	The first character sent by the DTE is lost by the module, but after ~5 ms the UART and the module are woken up: recognition of subsequent characters is guaranteed only after the UART / module complete wake-up (i.e. after ~5 ms). Data sent by the module is correctly received by the DTE if it is ready to receive data, otherwise the data is lost.
2	Enabled (AT&K3)	ON or OFF	ON or OFF	Not Applicable: HW flow control cannot be enabled with AT+UPSV=2.
2	Disabled (AT&K0)	ON	ON or OFF	Data sent by the DTE is correctly received by the module. Data sent by the module is correctly received by the DTE if it is ready to receive data, otherwise data is lost.
2	Disabled (AT&K0)	OFF	ON or OFF	The first character sent by the DTE is lost by the module, but after ~5 ms the UART and the module are woken up. Recognition of subsequent characters is guaranteed only after the UART / module complete wake-up (i.e. after ~5 ms). Data sent by the module is correctly received by the DTE if it is ready to receive data, otherwise data is lost.
3	Enabled (AT&K3)	ON	ON	Data sent by the DTE is correctly received by the module. Data sent by the module is correctly received by the DTE.
3	Enabled (AT&K3)	ON	OFF	Data sent by the DTE is buffered by the DTE and will be correctly received by the module when it is ready to receive data (when the UART is enabled). Data sent by the module is correctly received by the DTE.
3	Enabled (AT&K3)	OFF	ON	Data sent by the DTE is correctly received by the module. Data sent by the module is buffered by the module and will be correctly received by the DTE when it is ready to receive data (i.e. RTS line will be ON).
3	Enabled (AT&K3)	OFF	OFF	Data sent by the DTE is buffered by the DTE and will be correctly received by the module when it is ready to receive data (when the UART is enabled). Data sent by the module is buffered by the module and will be correctly received by the DTE when it is ready to receive data (i.e. RTS line will be ON).
3	Disabled (AT&K0)	ON or OFF	ON	Data sent by the DTE is correctly received by the module. Data sent by the module is correctly received by the DTE if it is ready to receive data, otherwise data is lost.
3	Disabled (AT&K0)	ON or OFF	OFF	The first character sent by the DTE is lost by the module, but after ~5 ms the UART and the module are woken up. Recognition of subsequent characters is guaranteed only after the UART / module complete wake-up (i.e. after ~5 ms). Data sent by the module is correctly received by the DTE if it is ready to receive data, otherwise data is lost.

Table 12: UART and power-saving summary

AT+UPSVM=0: power saving disabled, fixed active-mode

The module does not enter low power idle-mode and the UART interface is enabled (data can be sent and received): the **CTS** line is always held in the ON state after UART initialization. This is the default configuration.

AT+UPSVM=1: power saving enabled, cyclic idle/active-mode

When the AT+UPSVM=1 command is issued by the DTE, then the UART is immediately disabled by the module. Afterwards, the UART is enabled again, and the module does not enter low power idle-mode, as following:

- Periodically, during each paging reception (see section 1.5.1.5), to temporarily receive or send data over the UART, e.g. data buffered by the DTE with HW flow control enabled will be correctly received by the module
- If the module needs to transmit some data over the UART (e.g. URC), the UART is temporarily enabled
- If a data call with external context is activated, the UART is kept enabled
- If the DTE send data with HW flow control disabled, the first character sent causes the UART and module wake-up after ~5 ms: recognition of subsequent characters is guaranteed only after the complete wake-up (see the following subsection "wake up via data reception")

The module automatically enters the low power idle-mode whenever possible but it wakes up to active-mode according to the UART periodic wake up so that the module cyclically enters the low power idle-mode and the active-mode. Additionally, the module wakes up to active-mode according to any required activity related to the network (e.g. for the periodic paging reception described in section 1.5.1.5, or for any other required RF Tx / Rx) or any other required activity related to module functions / interfaces (including the UART itself).

When the UART interface is enabled, data can be received. When a character is received, it forces the UART interface to stay enabled for a longer time and it forces the module to stay in the active-mode for a longer time, according to the timeout configured by the second parameter of the +UPSVM AT command. The timeout can be set from 40 2G-frames (i.e. $40 \times 4.615 \text{ ms} = 184 \text{ ms}$) up to 65000 2G-frames (i.e. $65000 \times 4.615 \text{ ms} = 300 \text{ s}$). Default value is 2000 2G-frames (i.e. $2000 \times 4.615 \text{ ms} = 9.2 \text{ s}$). Every subsequent character received during the active-mode, resets and restarts the timer; hence the active-mode duration can be extended indefinitely.

The hardware flow-control output (**CTS** line) indicates when the UART interface is enabled (data can be sent and received), as illustrated in Figure 22.

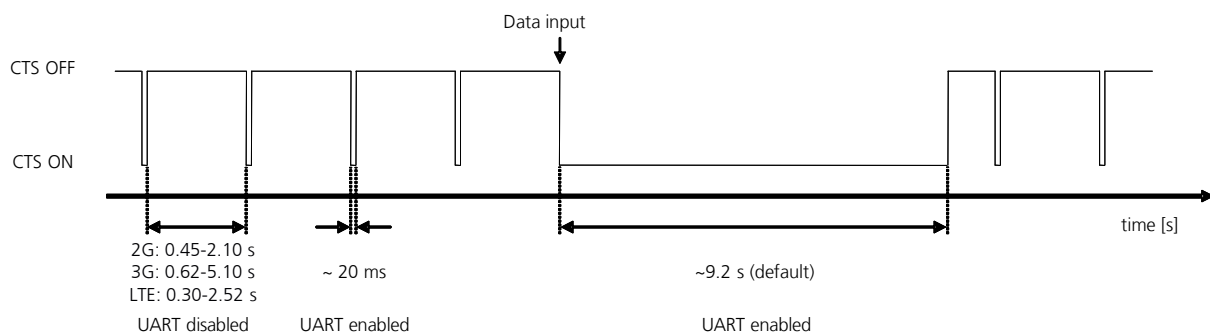

Figure 22: CTS output pin indicates when module's UART is enabled (CTS = ON = low level) or disabled (CTS = OFF = high level)

AT+UPSV=2: power saving enabled and controlled by the RTS line

This configuration can only be enabled with the module hardware flow control disabled (i.e. AT&K0 setting).

The UART interface is immediately disabled after the DTE sets the **RTS** line to OFF.

Afterwards, the UART is enabled again, and the module does not enter low power idle-mode, as following:

- If an OFF-to-ON transition occurs on the **RTS** input line, this causes the UART / module wake-up after ~5 ms: recognition of subsequent characters is guaranteed only after the complete wake-up, and the UART is kept enabled as long as the **RTS** input line is set to ON.
- If the module needs to transmit some data over the UART (e.g. URC)
- If a data call with external context is activated
- If the DTE sends data, the first character sent causes the UART and module wake-up after ~5 ms: the recognition of subsequent characters is guaranteed only after the complete wake-up, and the UART will be then kept enabled after the last data received according to the timeout previously set with the AT+UPSV=1 configuration (see the following subsection "wake up via data reception")

The module automatically enters the low power idle-mode whenever possible but it wakes up to active-mode according to any required activity related to the network (e.g. for the periodic paging reception described in section 1.5.1.5, or for any other required RF transmission / reception) or any other required activity related to the module functions / interfaces (including the UART itself).

The hardware flow-control output (**CTS** line) indicates when the UART interface is enabled (data can be sent and received) as illustrated in Figure 22, even if hardware flow control is disabled with AT+UPSV=2 configuration.

AT+UPSV=3: power saving enabled and controlled by the DTR line

The UART interface is immediately disabled after the DTE sets the **DTR** line to OFF.

Afterwards, the UART is enabled again, and the module does not enter low power idle-mode, as following:

- If an OFF-to-ON transition occurs on the **DTR** input line, this causes the UART / module wake-up after ~5 ms: recognition of subsequent characters is guaranteed only after the complete wake-up, and the UART is kept enabled as long as the **DTR** input line is set to ON
- If the module needs to transmit some data over the UART (e.g. URC)
- If a data call with external context is activated
- If the DTE sends data, the first character sent causes the UART and module wake-up after ~5 ms: recognition of subsequent characters is guaranteed only after the complete wake-up, and the UART will be then kept enabled after the last data received according to the timeout previously set with the AT+UPSV=1 configuration (see the following subsection "wake up via data reception")

The module automatically enters the low power idle-mode whenever possible but it wakes up to active-mode according to any required activity related to the network (e.g. for the periodic paging reception described in section 1.5.1.5, or for any other required RF signal transmission or reception) or any other required activity related to the functions / interfaces of the module.

The AT+UPSV=3 configuration can be enabled regardless the flow control setting on UART. In particular, the HW flow control can be enabled (AT&K3) or disabled (AT&K0) on UART during this configuration. In both cases, the **CTS** line indicates the UART power saving state as illustrated in Figure 22.

When the AT+UPSV=3 configuration is enabled, the **DTR** input line can still be used by the DTE to control the module behavior according to AT&D command configuration (see u-blox AT commands Manual [3]).

Wake up via data reception

The UART wake up via data reception consists of a special configuration of the module **TXD** input line that causes the system wake-up when a low-to-high transition occurs on the **TXD** input line. In particular, the UART is enabled and the module switches from the low power idle-mode to active-mode within ~5 ms from the first character received: this is the system “wake up time”.

As a consequence, the first character sent by the DTE when the UART is disabled (i.e. the wake up character) is not a valid communication character even if the wake up via data reception configuration is active, because it cannot be recognized, and the recognition of the subsequent characters is guaranteed only after the complete system wake-up (i.e. after ~5 ms).

The **TXD** input line is configured to wake up the system via data reception in the following cases:

- AT+UPSV=1 is set with HW flow control disabled
- AT+UPSV=2 is set with HW flow control disabled, and the **RTS** line is set OFF
- AT+UPSV=3 is set with HW flow control disabled, and the **DTR** line is set OFF

Figure 23 and Figure 24 show examples of common scenarios and timing constraints:

- AT+UPSV=1 power saving configuration is active and the timeout from last data received to idle-mode start is set to 2000 frames (AT+UPSV=1,2000)
- Hardware flow control is disabled

Figure 23 shows the case where the module UART is disabled and only a wake-up is forced. In this scenario the only character sent by the DTE is the wake-up character; as a consequence, the DCE module UART is disabled when the timeout from last data received expires (2000 frames without data reception, as the default case).

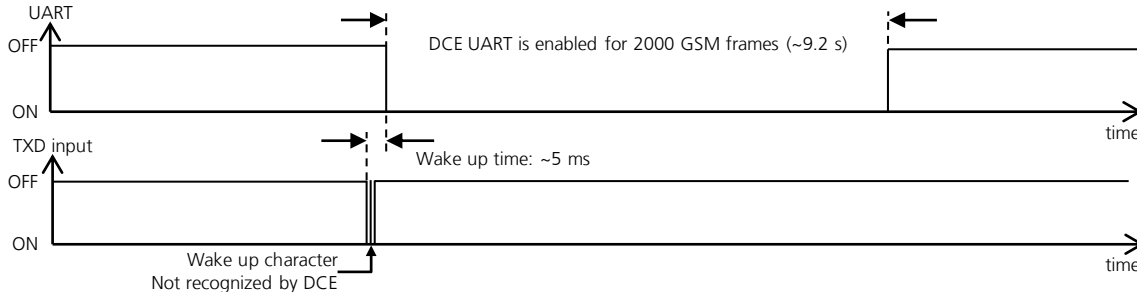

Figure 23: Wake-up via data reception without further communication

Figure 24 shows the case where in addition to the wake-up character further (valid) characters are sent. The wake up character wakes-up the module UART. The other characters must be sent after the “wake up time” of ~5 ms. If this condition is satisfied, the module (DCE) recognizes characters. The module will disable the UART after 2000 GSM frames from the latest data reception.

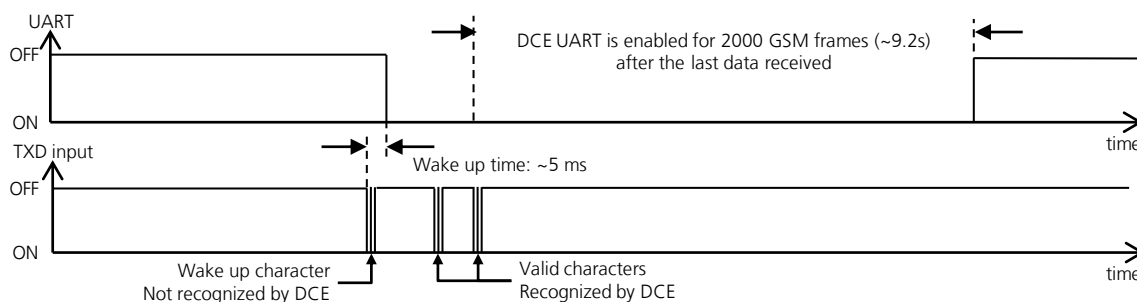





Figure 24: Wake-up via data reception with further communication

-  The “wake-up via data reception” feature cannot be disabled.
-  In command mode⁷, if autobauding is enabled and the DTE does not implement HW flow control, the DTE must always send a character to the module before the “AT” prefix set at the beginning of each command line: the first character is ignored if the module is in active-mode, or it represents the wake-up character if the module is in idle-mode.
-  In command mode⁷, the DTE should always send a dummy “AT” before each command line: the first character is not ignored if the module is in active-mode (i.e. the module replies “OK”), or it represents the wake up character if the module is in low power idle-mode (i.e. the module does not reply).
-  No wake-up character or dummy “AT” is required from the DTE during a data call with external context since the module UART interface continues to be enabled and does not need to be woken-up. Furthermore in data mode⁷ a dummy “AT” would affect the data communication.

Additional considerations

If the USB is connected and not suspended, the module is forced to stay in active-mode, therefore the AT+UPSV settings are overruled but they have effect on the UART behavior (they configure UART power saving, so that UART is enabled / disabled according to the AT+UPSV settings).

1.9.2.5 UART multiplexer protocol

TOBY-L2 series modules include multiplexer functionality as per 3GPP TS 27.010 [10], on the UART physical link.

This is a data link protocol which uses HDLC-like framing and operates between the module (DCE) and the application processor (DTE) and allows a number of simultaneous sessions over the used physical link (UART): the user can concurrently use AT interface on one MUX channel and data communication on another MUX channel.

The following virtual channels are defined (for more details, see Mux implementation Application Note [11]):

- Channel 0: control channel
- Channel 1 – 5: AT commands / data connection
- Channel 6: GNSS tunneling (not supported by “00”, “01”, “50” product versions)
- Channel 7: SIM Access Profile (SAP, not supported by “00”, “01”, “50” product versions)

⁷ See the u-blox AT Commands Manual [3] for the definition of the interface data mode, command mode and online command mode.

1.9.3 DDC (I²C) interface



The I²C bus compatible Display Data Channel interface is not available on the MPC1-L2 series modules, as AssistNow embedded GNSS positioning aiding, CellLocate[®] positioning through cellular information and custom functions over GPIOs for the integration with u-blox positioning chips / modules.



The I²C bus compatible Display Data Channel interface is not supported by the TOBY-L2 series modules "00", "01" and "50" product versions, as the AssistNow embedded GNSS positioning aiding, CellLocate[®] positioning through cellular information and custom functions over GPIOs for the integration with u-blox positioning chips / modules.

The **SDA** and **SCL** pins of TOBY-L2 series modules represent an I²C bus compatible Display Data Channel (DDC) interface for the communication with u-blox GNSS receivers and with other external I²C devices as audio codecs: an I²C master can communicate with more I²C slaves in accordance to the I²C bus specifications [12].

The DDC (I²C) interface is the only one interface dedicated for communication between u-blox cellular module and u-blox positioning receivers. The AT commands interface is not available on the DDC (I²C) interface.

The DDC (I²C) interface pads of the module, serial data (**SDA**) and serial clock (**SCL**), are open drain output and external pull up resistors must be used conforming to the I²C bus specifications [12].

u-blox has implemented special features in the cellular modules to ease the design effort for the integration of a u-blox cellular module with a u-blox GNSS receiver (details in GNSS Implementation Application Note [13]).

Combining a u-blox cellular module with a u-blox GNSS receiver allows designers to full access the GNSS receiver directly via the cellular module: it relays control messages to the GNSS receiver via a dedicated DDC (I²C) interface. A 2nd interface connected to the GNSS receiver is not necessary: AT commands via the AT interfaces of the cellular module (UART, USB) allows a full control of the GNSS receiver from any host processor.

u-blox cellular modules feature embedded GNSS aiding that is a set of specific features developed by u-blox to enhance GNSS performance, decreasing Time To First Fix (TTFF), thus allowing to calculate the position in a shorter time with higher accuracy.

Additional custom functions over GPIO pins are designed to improve the integration with u-blox GNSS receivers:

- GNSS receiver power-on/off: "GNSS supply enable" function over the **GPIO2** pin improves the positioning receiver power consumption. When the GNSS functionality is not required, the positioning receiver can be completely switched off by the cellular module controlled by the application processor over AT commands
- The wake up from idle-mode when the GNSS receiver is ready to send data: "GNSS data ready" function over the **GPIO3** pin improves the cellular module power consumption. When power saving is enabled in the cellular module by the AT+UPSV command and the GNSS receiver does not send data by the DDC (I²C) interface, the module automatically enters idle-mode whenever possible. With the "GNSS data ready" function the GNSS receiver can indicate to the cellular module that it is ready to send data: the positioning receiver can wake up the cellular module to avoid data loss even if power saving is enabled.
- The RTC synchronization signal to the GNSS receiver: "GNSS RTC sharing" function over the **GPIO4** pin improves GNSS receiver performance, decreasing the Time To First Fix (TTFF), and thus allowing to calculate the position in a shorter time with higher accuracy. When GNSS local aiding is enabled, the cellular module automatically uploads data such as position, time, ephemeris, almanac, health and ionospheric parameter from the positioning receiver into its local memory, and restores this to the GNSS receiver at the next power up of the positioning receiver

1.9.4 Secure Digital Input Output interface (SDIO)



Secure Digital Input Output interface is not available on MPC1-L2 series modules.



Secure Digital Input Output interface is not supported by TOBY-L2 “00” and “01” product versions.

TOBY-L2 series modules include a 4-bit Secure Digital Input Output interface (**SDIO_D0, SDIO_D1, SDIO_D2, SDIO_D3, SDIO_CLK, SDIO_CMD**) designed to communicate with an external u-blox short range Wi-Fi module: the TOBY-L2 cellular module acts as an SDIO host controller which can communicate over the SDIO bus with a compatible u-blox short range Wi-Fi module acting as SDIO device.

The SDIO interface is the only one interface of TOBY-L2 series modules dedicated for communication between the u-blox cellular module and the u-blox short range Wi-Fi module. The AT commands interface is not available on the SDIO interface of TOBY-L2 series modules.

The SDIO interface supports 50 MHz bus clock frequency, which allows a data throughput of 200 Mb/s.

Combining a u-blox cellular module with a u-blox short range communication module gives designers full access to the Wi-Fi module directly via the cellular module, so that a second interface connected to the Wi-Fi module is not necessary. AT commands via the AT interfaces of the cellular module (UART, USB) allows a full control of the Wi-Fi module from any host processor, because Wi-Fi control messages are relayed to the Wi-Fi module via the dedicated SDIO interface (for more details, see the Wi-Fi AT commands in the u-blox AT Commands Manual [3]).

u-blox has implemented special features in the cellular modules to ease the design effort for the integration of a u-blox cellular module with a u-blox short range Wi-Fi module to provide both Bridge and Router functionality (for more details, see the Wi-Fi / Cellular Integration Application Note [14]).

Additional custom functions over GPIO pins are designed to improve the integration with u-blox Wi-Fi modules:

- Wi-Fi enable Switch-on / switch-off the Wi-Fi
- Wi-Fi reset Reset the Wi-Fi
- Wi-Fi data ready Cellular module wake-up when the Wi-Fi is ready for sending data over SDIO
- Wi-Fi power saving Enable/disable the low power mode of the Wi-Fi
- 32 kHz output Clock for the Wi-Fi
- 26 MHz output Clock for the Wi-Fi



GPIOs are not supported by TOBY-L2 “00”, “01”, and “50” product versions, except for:

- Wireless Wide Area Network status indication configured on **GPIO1** of “00”, “01” product versions
- Wi-Fi enable function configured on the **GPIO1** of “50” product version



GPIOs are not available on MPC1-L2 series modules.

1.10 Audio

1.10.1 Digital audio over I²S interface



Digital audio over I²S interface is not available on MPC1-L2 series modules.



Digital audio over I²S interface is not supported by TOBY-L2 modules “00”, “01”, “50” product versions.

TOBY-L2 series modules include a 4-wire I²S digital audio interface (**I2S_TXD, I2S_RXD, I2S_CLK, I2S_WA**) that can be configured by AT command to transfer digital audio data with an external device as an audio codec (for more details see u-blox AT Commands Manual [3]).

1.11 General Purpose Input/Output



GPIOs are not supported by TOBY-L2 series modules “00”, “01” and “50” product versions, except for:

- Wireless Wide Area Network status indication configured on **GPIO1** of “00”, “01” product versions
- Wi-Fi enable function configured on the **GPIO1** of “50” product version



GPIOs are not available on MPC1-L2 series modules.

TOBY-L2 series modules include 14 pins (**GPIO1-GPIO6, I2S_TXD, I2S_RXD, I2S_CLK, I2S_WA, DTR, DSR, DCD, RI**) that can be configured as General Purpose Input/Output or to provide custom functions via u-blox AT commands (see the u-blox AT Commands Manual [3]), as summarized in Table 13.

Function	Description	Default GPIO	Configurable GPIOs
Network status indication	Network status: registered home network, registered roaming, data transmission, no service	GPIO1	GPIO1
GNSS supply enable	Enable/disable the supply of u-blox GNSS receiver connected to cellular module	GPIO2	GPIO2
GNSS data ready	Sense when u-blox GNSS receiver connected to the module is ready for sending data by the DDC (I ² C)	GPIO3	GPIO3
GNSS RTC sharing	Real Time Clock synchronization signal to u-blox GNSS receiver connected to cellular module	GPIO4	GPIO4
SIM card detection	SIM card physical presence detection	GPIO5	GPIO5
SIM card hot insertion/removal	SIM card hot insertion/removal	--	GPIO5
I ² S digital audio interface	I2S digital audio interface	I2S_RXD, I2S_TXD, I2S_CLK, I2S_WA	I2S_RXD, I2S_TXD, I2S_CLK, I2S_WA
26 MHz clock output	26 MHz clock output for an external audio codec or an external Wi-Fi chip/module	GPIO6	GPIO6
Wi-Fi enable	Enable/disable the supply of the external Wi-Fi chip or module connected to the cellular module	--	GPIO1, GPIO4, DSR
Wi-Fi data ready	Sense when the external Wi-Fi chip/module connected to the cellular module is ready for sending data by the SDIO, waking up the cellular module from low power idle mode	--	GPIO3, DTR
Wi-Fi reset	Reset the external Wi-Fi chip or module connected to the cellular module	--	GPIO3, DCD
Wi-Fi power saving	Enable/disable the low power mode of the external Wi-Fi chip/module connected to the cellular module	--	GPIO2, RI
32 kHz clock output	32 kHz clock output for an external Wi-Fi chip or module	--	GPIO6
Antenna tuning	4-bit tunable antenna control signals mapping the actual operating RF band over a 4-pin interface provided for the implementation of external antenna tuning solutions	--	I2S_RXD, I2S_TXD, I2S_CLK, I2S_WA, DSR, DTR, DCD, RI
DSR	UART data set ready output	DSR	DSR
DTR	UART data terminal ready input	DTR	DTR
DCD	UART data carrier detect output	DCD	DCD
RI	UART ring indicator output	RI	RI
General purpose input	Input to sense high or low digital level	--	All
General purpose output	Output to set the high or the low digital level	--	All
Pin disabled	Tri-state with an internal active pull-down enabled	--	All

Table 13: TOBY-L2 series GPIO custom functions configuration

1.12 Mini PCIe specific signals (**W_DISABLE#**, **LED_WWAN#**)



Mini PCI Express specific signals (**W_DISABLE#**, **LED_WWAN#**) are not available on TOBY-L2 series.

MPCI-L2 series modules include the **W_DISABLE#** active-low input signal to disable the radio operations as specified by the PCI Express Mini Card Electromechanical Specification [15].

As described in Figure 25, the **W_DISABLE#** input is equipped with an internal pull-up to the **3.3Vaux** supply. The **W_DISABLE#** input detailed electrical characteristics are described in the MPCI-L2 series Data Sheet [2].

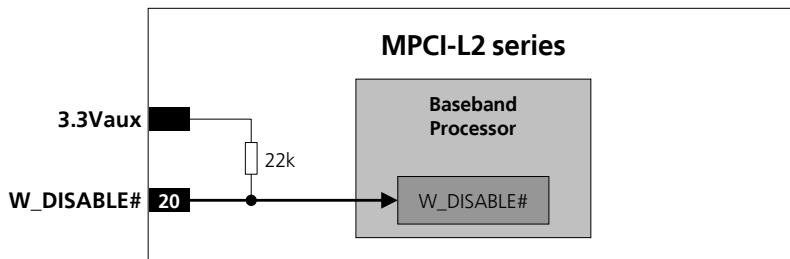

Figure 25: MPCI-L2 series modules **W_DISABLE#** input circuit description

MPCI-L2 series modules include the **LED_WWAN#** active-low open drain output to provide the Wireless Wide Area Network status indication as specified by the PCI Express Mini Card Electromechanical Specification [15].



For more electrical characteristics details see the MPCI-L2 Data Sheet [2].

1.13 Reserved pins (RSVD)



Pins reserved for future use, marked as **RSVD**, are not available on MPCI-L2 series.

TOBY-L2 series modules have pins reserved for future use, marked as **RSVD**: they can all be left unconnected on the application board, except the **RSVD** pin number **6** that must be externally connected to ground.

1.14 Not connected pins (NC)





Pins internally not connected, marked as **NC**, are not available on TOBY-L2 series.

MPCI-L2 series modules have pins internally not connected, marked as **NC**: they can be left unconnected or they can be connected on the application board according to any application requirement, given that none function is provided by the modules over these pins.

1.15 System features

1.15.1 Network indication

 Network status indication over **GPIO1** is not available on MPC1-L2 series modules which include the **LED_WWAN#** active-low open drain output to provide the Wireless Wide Area Network status indication as specified by the PCI Express Mini Card Electromechanical Specification [15].

 GPIOs are not supported by TOBY-L2 modules "00", "01", "50" product versions, but the Wireless Wide Area Network status indication is by default configured on the **GPIO1** of "00", "01" product version.

The **GPIO1** can be configured by the AT+UGPIOC command (for further details see the u-blox AT Commands Manual [3]), to indicate network status as described below:

- No service (no network coverage or not registered)
- Registered 2G / 3G / LTE home network
- Registered 2G / 3G / LTE visitor network (roaming)
- Call enabled (RF data transmission / reception)

1.15.2 Antenna supervisor

 Antenna supervisor (i.e. antenna detection) is not available on MPC1-L2 series.

 Antenna supervisor (i.e. antenna detection) is not supported by TOBY-L2 series modules "00", "01" and "50" product versions.

The antenna detection function provided by the **ANT_DET** pin is based on an ADC measurement as optional feature that can be implemented if the application requires it. The antenna supervisor is forced by the +UANTR AT command (see the u-blox AT Commands Manual [3] for more details).

The requirements to achieve antenna detection functionality are the following:

- an RF antenna assembly with a built-in resistor (diagnostic circuit) must be used
- an antenna detection circuit must be implemented on the application board

See section 1.7.2 for detailed antenna detection interface functional description and see section 2.4.2 for detection circuit on application board and diagnostic circuit on antenna assembly design-in guidelines.

1.15.3 Jamming detection

 Congestion detection (i.e. jamming detection) is not supported by "00", "01" and "50" product versions.

In real network situations modules can experience various kind of out-of-coverage conditions: limited service conditions when roaming to networks not supporting the specific SIM, limited service in cells which are not suitable or barred due to operators' choices, no cell condition when moving to poorly served or highly interfered areas. In the latter case, interference can be artificially injected in the environment by a noise generator covering a given spectrum, thus obscuring the operator's carriers entitled to give access to the LTE/3G/2G service.

The congestion (i.e. jamming) detection feature can be enabled and configured by the +UCD AT command: the feature consists of detecting an anomalous source of interference and signaling the start and stop of such conditions to the host application processor with an unsolicited indication, which can react appropriately by e.g. switching off the radio transceiver of the module (i.e. configuring the module in "airplane mode" by means of the +CFUN AT command) in order to reduce power consumption and monitoring the environment at constant periods (for more details see the u-blox AT Commands Manual [3]).

1.15.4 IP modes of operation

IP modes of operation refer to the TOBY-L2 and MPC1-L2 series modules configuration related to the network IP termination and network interfaces settings in general. IP modes of operation are the following:

- **Bridge mode:** In bridge mode the module acts as a cellular modem dongle connected to the host over serial interface. The IP termination of the network is placed on the host IP stack. The module is configured as a bridge which means the network IP address is assigned to the host (host IP termination).
- **Router mode:** In router mode the module acts as a cellular modem router which means the IP termination of the network is placed on the internal IP stack of the module (on-target IP termination). In particular, in this configuration the application processor belongs to a private network and is not aware of the mobile connectivity setup of the module.

For more details about IP modes of operation see the u-blox AT Commands Manual [3].

1.15.5 Dual stack IPv4/IPv6

TOBY-L2 and MPC1-L2 series support both Internet Protocol version 4 and Internet Protocol version 6 in parallel. For more details about dual stack IPv4/IPv6 see the u-blox AT Commands Manual [3].

1.15.6 TCP/IP and UDP/IP



Embedded TCP/IP and UDP/IP stack as well as Direct Link mode are not supported by the “00” and “50” product versions.

TOBY-L2 and MPC1-L2 series modules provide embedded TCP/IP and UDP/IP protocol stack: a PDP context can be configured, established and handled via the data connection management packet switched data commands.

TOBY-L2 and MPC1-L2 series modules provide Direct Link mode to establish a transparent end-to-end communication with an already connected TCP or UDP socket via serial interfaces (USB, UART). In Direct Link mode, data sent to the serial interface from an external application processor is forwarded to the network and vice-versa.

For more details about embedded TCP/IP and UDP/IP functionalities see the u-blox AT Commands Manual [3].

1.15.7 FTP



Embedded FTP services as well as Direct Link mode are not supported by “00” and “50” product versions.

TOBY-L2 and MPC1-L2 series provide embedded File Transfer Protocol (FTP) services. Files are read and stored in the local file system of the module.

FTP files can also be transferred using FTP Direct Link:

- **FTP download:** data coming from the FTP server is forwarded to the host processor via USB / UART serial interfaces (for FTP without Direct Link mode the data is always stored in the module’s Flash File System)
- **FTP upload:** data coming from the host processor via USB / UART serial interface is forwarded to the FTP server (for FTP without Direct Link mode the data is read from the module’s Flash File System)

When Direct Link is used for a FTP file transfer, only the file content pass through USB / UART serial interface, whereas all the FTP commands handling is managed internally by the FTP application.

For more details about embedded FTP functionalities see u-blox AT Commands Manual [3].

1.15.8 HTTP



Embedded HTTP services are not supported by “00” and “50” product versions.

TOBY-L2 and MPC1-L2 series modules provide the embedded Hyper-Text Transfer Protocol (HTTP) services via AT commands for sending requests to a remote HTTP server, receiving the server response and transparently storing it in the module’s Flash File System (FFS).

For more details about embedded HTTP functionalities see the u-blox AT Commands Manual [3].

1.15.9 SSL



Embedded Transport Layer Security (TLS) / Secure Sockets Layer (SSL) protocols are not supported by the “00”, “01” and “50” product versions.

TOBY-L2 and MPC1-L2 series modules provide the Transport Layer Security (TLS) / Secure Sockets Layer (SSL) encryption protocols to enable security over the FTP and HTTP protocols via AT commands, implementing Secure File Transfer Protocol (FTPS, i.e. FTP with TLS / SSL encryption) and Secure Hyper-Text Transfer Protocol (HTTPS, i.e. HTTP with TLS / SSL encryption) services.

For more details about embedded TLS / SSL functionalities see the u-blox AT Commands Manual [3].

1.15.10 AssistNow clients and GNSS integration



AssistNow clients and u-blox GNSS receiver integration are not available on the MPC1-L2 series modules.



AssistNow clients and u-blox GNSS receiver integration are not supported by the TOBY-L2 series modules “00”, “01” and “50” product versions.

For customers using u-blox GNSS receivers, TOBY-L2 series cellular modules feature embedded AssistNow clients. AssistNow A-GPS provides better GNSS performance and faster Time-To-First-Fix. The clients can be enabled and disabled with an AT command (see the u-blox AT Commands Manual [3]).

TOBY-L2 series cellular modules act as a stand-alone AssistNow client, making AssistNow available with no additional requirements for resources or software integration on an external host micro controller. Full access to u-blox GNSS receivers is available via the TOBY-L2 series cellular module, through the DDC (I²C) interface, while the available GPIOs can handle the positioning chipset / module power-on/off. This means that cellular module and GNSS receiver can be controlled through a single serial port from any host processor.

1.15.11 Hybrid positioning and CellLocate[®]



Hybrid positioning and CellLocate[®] are not available on MPC1-L2 series.



Hybrid positioning and CellLocate[®] are not supported by the TOBY-L2 series modules “00”, “01” and “50” product versions.

Although GNSS is a widespread technology, its reliance on the visibility of extremely weak GNSS satellite signals means that positioning is not always possible. Especially difficult environments for GNSS are indoors, in enclosed or underground parking garages, as well as in urban canyons where GNSS signals are blocked or jammed by multipath interference. The situation can be improved by augmenting GNSS receiver data with cellular network information to provide positioning information even when GNSS reception is degraded or absent. This additional information can benefit numerous applications.

Positioning through cellular information: CellLocate®

u-blox CellLocate® enables the estimation of device position based on the parameters of the mobile network cells visible to the specific device. To estimate its position the u-blox cellular module sends the CellLocate® server the parameters of network cells visible to it using a UDP connection. In return the server provides the estimated position based on the CellLocate® database. The u-blox cellular module can either send the parameters of the visible home network cells only (normal scan) or the parameters of all surrounding cells of all mobile operators (deep scan).

The CellLocate® database is compiled from the position of devices which observed, in the past, a specific cell or set of cells (historical observations) as follows:

1. Several devices reported their position to the CellLocate® server when observing a specific cell (the As in the picture represent the position of the devices which observed the same cell A)

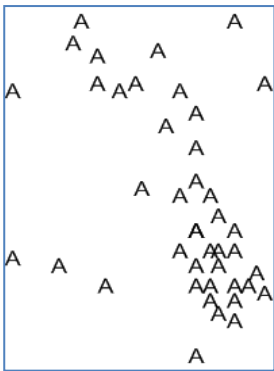

2. CellLocate® server defines the area of Cell A visibility

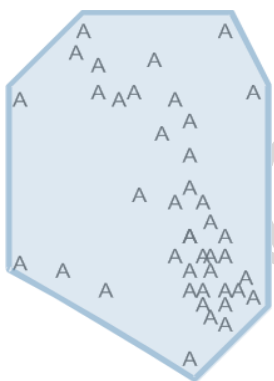

3. If a new device reports the observation of Cell A CellLocate[®] is able to provide the estimated position from the area of visibility

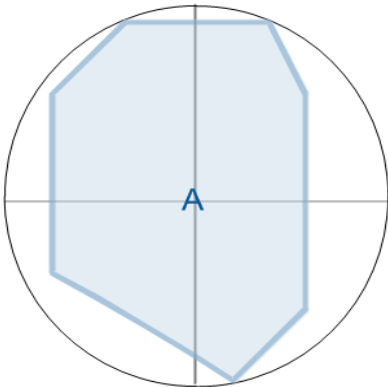

4. The visibility of multiple cells provides increased accuracy based on the intersection of areas of visibility.

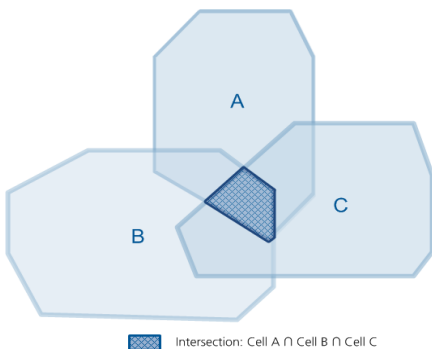

CellLocate[®] is implemented using a set of two AT commands that allow configuration of the CellLocate[®] service (AT+ULOCCELL) and requesting position according to the user configuration (AT+ULOC). The answer is provided in the form of an unsolicited AT command including latitude, longitude and estimated accuracy.



The accuracy of the position estimated by CellLocate[®] depends on the availability of historical observations in the specific area.

Hybrid positioning

With u-blox Hybrid positioning technology, u-blox cellular devices can be triggered to provide their current position using either a u-blox GNSS receiver or the position estimated from CellLocate[®]. The choice depends on which positioning method provides the best and fastest solution according to the user configuration, exploiting the benefit of having multiple and complementary positioning methods.

Hybrid positioning is implemented through a set of three AT commands that allow configuration of the GNSS receiver (AT+ULOCGNSS), configuration of the CellLocate[®] service (AT+ULOCCELL), and requesting the position according to the user configuration (AT+ULOC). The answer is provided in the form of an unsolicited AT command including latitude, longitude and estimated accuracy (if the position has been estimated by CellLocate[®]), and additional parameters if the position has been computed by the GNSS receiver.

The configuration of mobile network cells does not remain static (e.g. new cells are continuously added or existing cells are reconfigured by the network operators). For this reason, when a Hybrid positioning method has been triggered and the GNSS receiver calculates the position, a database self-learning mechanism has been implemented so that these positions are sent to the server to update the database and maintain its accuracy.

The use of hybrid positioning requires a connection via the DDC (I²C) bus between the TOBY-L2 series cellular module and the u-blox GNSS receiver (see sections 1.9.3 and 2.6.3).

See GNSS Implementation Application Note [13] for the complete description of the feature.



u-blox is extremely mindful of user privacy. When a position is sent to the CellLocate[®] server u-blox is unable to track the SIM used or the specific device.

1.15.12 Wi-Fi integration



u-blox short range communication Wi-Fi modules integration is not available for MPC1-L2 series modules.



u-blox short range communication Wi-Fi modules integration is not supported by the TOBY-L2 series modules "00" and "01" product versions.

Full access to u-blox short range communication Wi-Fi modules is available through a dedicated SDIO interface (see sections 1.9.4 and 2.6.4). This means that combining a TOBY-L2 series cellular module with a u-blox short range communication module gives designers full access to the Wi-Fi module directly via the cellular module, so that a second interface connected to the Wi-Fi module is not necessary.

AT commands via the AT interfaces of the cellular module (UART, USB) allows a full control of the Wi-Fi module from any host processor, because Wi-Fi control messages are relayed to the Wi-Fi module via the dedicated SDIO interface (for more details, see the Wi-Fi AT commands in the u-blox AT Commands Manual [3]).

All the management software for Wi-Fi module operations runs inside the cellular module in addition to those required for cellular-only operation: Wi-Fi driver, Web User Interface (WebUI), Connection Config Manager.

For more details, see the Wi-Fi / Cellular Integration Application Note [14].

1.15.13 Firmware update Over AT (FOAT)

This feature allows upgrading the module firmware over USB / UART serial interfaces, using AT commands.

- The +UFWUPD AT command triggers a reboot followed by the upgrade procedure at specified a baud rate
- A special boot loader on the module performs firmware installation, security verifications and module reboot
- Firmware authenticity verification is performed via a security signature during the download. The firmware is then installed, overwriting the current version. In case of power loss during this phase, the boot loader detects a fault at the next wake-up, and restarts the firmware download. After completing the upgrade, the module is reset again and wakes-up in normal boot

For more details about Firmware update Over AT procedure see the Firmware Update Application Note [4] and the u-blox AT Commands Manual [3], +UFWUPD AT command.

1.15.14 Firmware update Over The Air (FOTA)



Firmware update Over The Air (FOTA) is not supported by "00" and "50" product versions.

This feature allows upgrading the module firmware over the LTE/3G/2G air interface.

In order to reduce the amount of data to be transmitted over the air, the implemented FOTA feature requires downloading only a "delta file" instead of the full firmware. The delta file contains only the differences between the two firmware versions (old and new), and is compressed. The firmware update procedure can be triggered using dedicated AT command with the delta file stored in the module file system via over the air FTP.

For more details about Firmware update Over The Air procedure see the Firmware Update Application Note [4] and the u-blox AT Commands Manual [3], +UFWINSTALL AT command.

1.15.15 In-band Modem (eCall / ERA-GLONASS)



In-band modem for eCall / ERA-GLONASS emergency applications is not supported by TOBY-L2 series modules "00", "01", and "50" product versions and by MPC1-L2 series modules.

In-band Modem solution for eCall and ERA-GLONASS emergency call applications over cellular networks is implemented according to 3GPP TS 26.267 [16], BS EN 16062:2011 [17] and ETSI TS 122 101 [18] specifications.

eCall (European) and ERA-GLONASS (Russian) are initiatives to combine mobile communications and satellite positioning to provide rapid assistance to motorists in the event of a collision, implementing automated emergency response system based the first on GPS the latter on GLONASS positioning system.

When activated, the in-vehicle systems (IVS) automatically initiate an emergency call carrying both voice and data (including location data) directly to the nearest Public Safety Answering Point (PSAP) to determine whether rescue services should be dispatched to the known position.

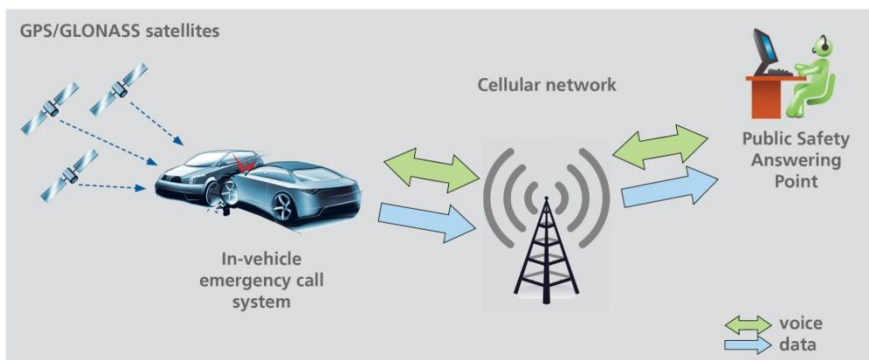

Figure 26: eCall and ERA-GLONASS automated emergency response systems diagram flow

For more details regarding the In-band Modem solution for the European eCall and the Russian ERA-GLONASS emergency call applications, see the u-blox eCall / ERA-GLONASS Application Note [19].

1.15.16 SIM Access Profile (SAP)



SIM Access Profile (SAP) is not supported by TOBY-L2 "00", "01", and "50" product versions or by MPC1-L2 series modules.

SIM access profile (SAP) feature allows accessing and using a remote SIM card / chipping instead of the local SIM directly connected to the module SIM interface.

A dedicated SAP channel over USB and a dedicated multiplexed SAP channel over UART are implemented for communication with the remote SIM card/chip.

Communication between TOBY-L2 series module and the remote SIM is conformed to client-server paradigm: The module is the SAP client establishing a connection and performing data exchange to a SAP server directly connected to the remote SIM that is used by the module for LTE/3G/2G network-related operations. The SAP communication protocol is based on the SIM Access Profile Interoperability Specification [20].

A typical application using the SAP feature is the scenario where a device such as an embedded car-phone with an integrated TOBY-L2 series module uses a remote SIM included in an external user device (e.g. a simple SIM card reader or a portable phone), which is brought into the car. The car-phone accesses the LTE/3G/2G network using the remote SIM in the external device.

TOBY-L2 series modules, acting as an SAP client, can be connected to an SAP server by a completely wired connection, as shown in Figure 27.

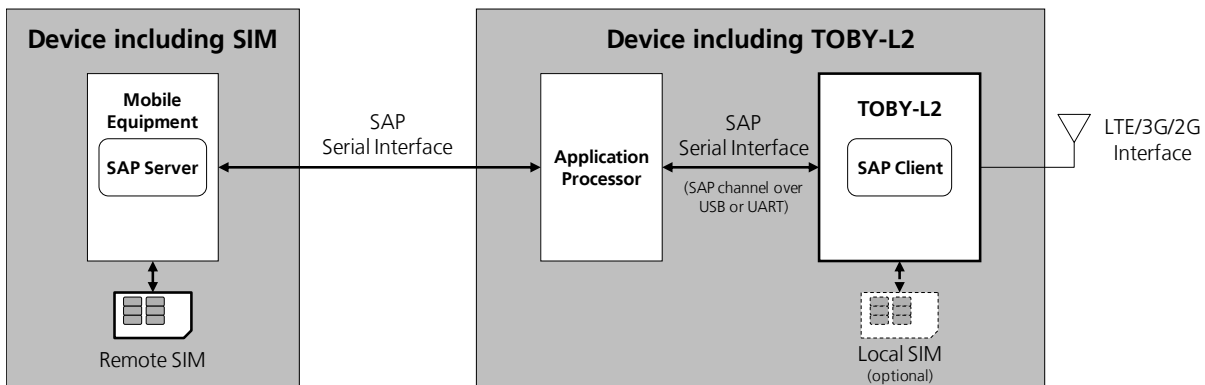

Figure 27: Remote SIM access via completely wired connection

As stated in the SIM Access Profile Interoperability Specification [20], the SAP client can be connected to the SAP server by means of a Bluetooth wireless link, using additional Bluetooth transceivers. In this case, the application processor wired to TOBY-L2 series module establishes and controls the Bluetooth connection using the SAP profile, and routes data received over a serial interface channel to data transferred over a Bluetooth interface and vice versa, as shown in Figure 28.

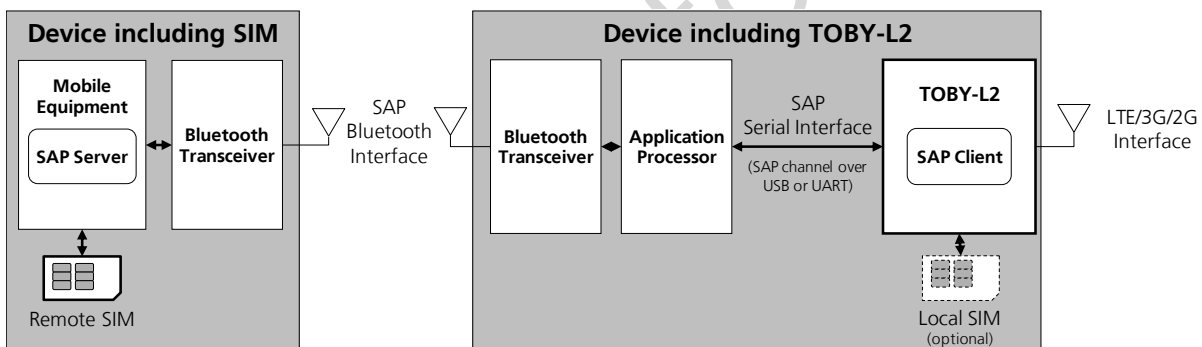

Figure 28: Remote SIM access via Bluetooth and wired connection

The application processor can start an SAP connection negotiation between TOBY-L2 series module SAP client and an SAP server using custom AT command (for more details see u-blox AT Commands Manual [3]).

While the connection with the SAP server is not fully established, the TOBY-L2 series module continues to operate with the attached (local) SIM, if present. Once the connection is established and negotiated, the module performs a detach operation from the local SIM followed by an attach operation to the remote one. Then the remotely attached SIM is used for any LTE/3G/2G network operation.

URC indications are provided to inform the user about the state of both the local and remote SIM. The insertion and the removal of the local SIM card are notified if a proper card presence detection circuit using the **GPIO5** of TOBY-L2 series modules is implemented as shown in section 2.5, and if the related “SIM card detection” and “SIM hot insertion/removal” functions described in section 1.8.2 are enabled by AT commands (for more details see u-blox AT Commands Manual [3]).

Upon SAP deactivation, the TOBY-L2 series modules perform a detach operation from the remote SIM followed by an attach operation to the local one, if present.

1.15.17 Smart temperature management

Smart temperature management is not supported by "00", "01", and "50" product versions.

Cellular modules – independent of the specific model – always have a well defined operating temperature range. This range should be respected to guarantee full device functionality and long life span.

Nevertheless there are environmental conditions that can affect operating temperature, e.g. if the device is located near a heating/cooling source, if there is/isn't air circulating, etc.

The module itself can also influence the environmental conditions; such as when it is transmitting at full power. In this case its temperature increases very quickly and can raise the temperature nearby.

The best solution is always to properly design the system where the module is integrated. Nevertheless an extra check/security mechanism embedded into the module is a good solution to prevent operation of the device outside of the specified range.

Smart Temperature Supervisor (STS)

The Smart Temperature Supervisor is activated and configured by a dedicated AT+USTS command. See the u-blox AT Commands Manual [3] for more details.

The cellular module measures the internal temperature (T_i) and its value is compared with predefined thresholds to identify the actual working temperature range.

Temperature measurement is done inside the cellular module: the measured value could be different from the environmental temperature (T_a).

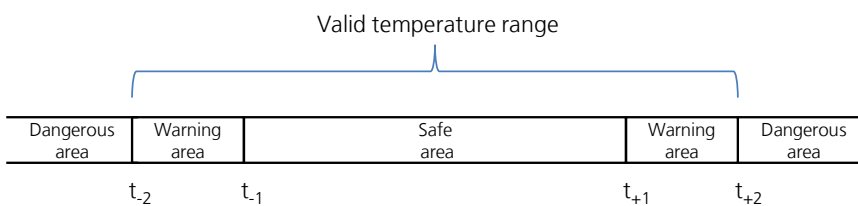

Figure 29: Temperature range and limits

The entire temperature range is divided into sub-regions by limits (see Figure 29) named t_{-2} , t_{-1} , t_{+1} and t_{+2} .

- Within the first limit, ($t_{-1} < T_i < t_{+1}$), the cellular module is in the normal working range, the Safe Area
- In the Warning Area, ($t_{-2} < T_i < t_{-1}$) or ($t_{+1} < T_i < t_{+2}$), the cellular module is still inside the valid temperature range, but the measured temperature approaches the limit (upper or lower). The module sends a warning to the user (through the active AT communication interface), which can take, if possible, the necessary actions to return to a safer temperature range or simply ignore the indication. The module is still in a valid and good working condition
- Outside the valid temperature range, ($T_i < t_{-2}$) or ($T_i > t_{+2}$), the device is working outside the specified range and represents a dangerous working condition. This condition is indicated and the device shuts down to avoid damage

For security reasons the shutdown is suspended in case an emergency call in progress. In this case the device will switch off at call termination.

The user can decide at anytime to enable/disable the Smart Temperature Supervisor feature. If the feature is disabled there is no embedded protection against disallowed temperature conditions.

Figure 30 shows the flow diagram implemented for the Smart Temperature Supervisor.

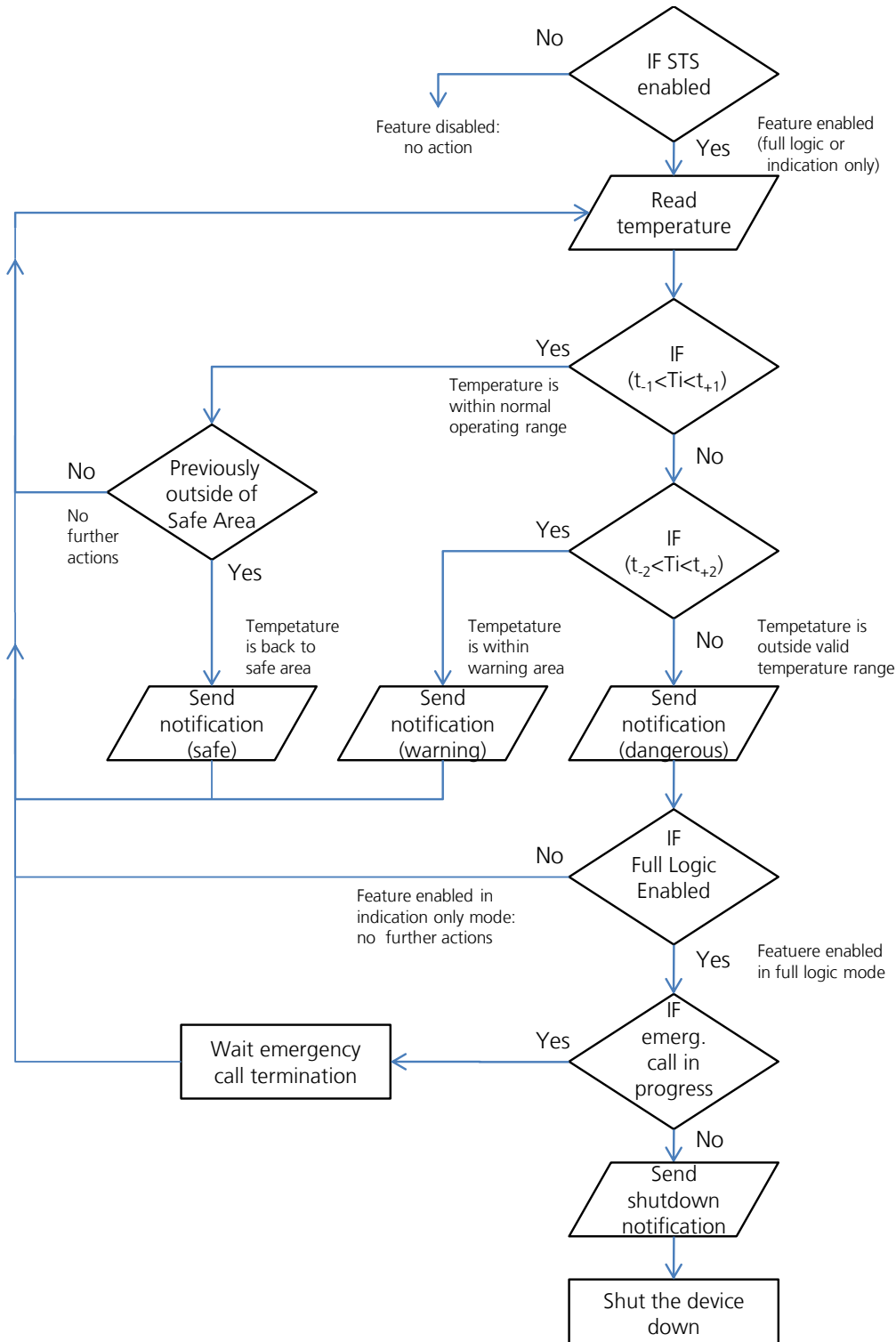

Figure 30: Smart Temperature Supervisor (STS) flow diagram

Threshold Definitions

When the application of cellular module operates at extreme temperatures with Smart Temperature Supervisor enabled, the user should note that outside the valid temperature range the device will automatically shut down as described above.

The input for the algorithm is always the temperature measured within the cellular module (T_i , internal). This value can be higher than the working ambient temperature (T_a , ambient), as (for example) during transmission at maximum power a significant fraction of DC input power is dissipated as heat. This behavior is partially compensated by the definition of the upper shutdown threshold (t_{+2}) that is slightly higher than the declared environmental temperature limit.



The sensor measures board temperature inside the shields, which can differ from ambient temperature.

1.15.18 Power saving

The power saving configuration is by default disabled, but it can be enabled using the AT+UPSV command (for the complete description of the AT+UPSV command, see the u-blox AT Commands Manual [3]).

When power saving is enabled, the module automatically enters the low power idle-mode whenever possible, reducing current consumption (see section 1.5.1.5, TOBY-L2 Data Sheet [1] and MPC1-L2 Data Sheet [2]).

During the low power idle-mode, the module is not ready to communicate with an external device, as it is configured to reduce power consumption. The module wakes up from low power idle-mode to active-mode in the following events:

- Automatic periodic monitoring of the paging channel for the reception of the paging block sent by the base station according to network conditions (see section 1.5.1.5)
- The connected USB host forces a remote wakeup of the module as USB device (see section 1.9.1.4)
- Automatic periodic enable of the UART interface to receive / send data, with AT+UPSV=1 (see 1.9.2.4)
- Data received on UART interface, with HW flow control disabled and AT+UPSV=1 (see 1.9.2.4)
- **RTS** input set ON by the host DTE, with HW flow control disabled and AT+UPSV=2 (see 1.9.2.4)
- **DTR** input set ON by the host DTE, with AT+UPSV=3 (see 1.9.2.4)
- The connected SDIO device forces a wakeup of the module as SDIO host (see 1.9.4)
- A preset RTC alarm occurs (see u-blox AT Commands Manual [3], AT+CALA)

For the definition and the description of TOBY-L2 and MPC1-L2 series modules operating modes, including the events forcing transitions between the different operating modes, see the section 1.4.

2 Design-in

2.1 Overview

For an optimal integration of TOBY-L2 and MPC1-L2 series modules in the final application board follow the design guidelines stated in this section.

Every application circuit must be properly designed to guarantee the correct functionality of the relative interface, however a number of points require high attention during the design of the application device.

The following list provides a rank of importance in the application design, starting from the highest relevance:

1. Module antenna connection: **ANT1**, **ANT2** and **ANT_DET**.
Antenna circuit directly affects the RF compliance of the device integrating a TOBY-L2 and MPC1-L2 series module with applicable certification schemes. Very carefully follow the suggestions provided in the relative section 2.4 for schematic and layout design.
2. Module supply: **VCC** or **3.3Vaux** and **GND** pins.
The supply circuit affects the RF compliance of the device integrating a TOBY-L2 and MPC1-L2 series module with applicable required certification schemes as well as antenna circuit design. Very carefully follow the suggestions provided in the relative section 2.2.1 for schematic and layout design.
3. USB interface: **USB_D+**, **USB_D-** pins.
Accurate design is required to guarantee USB 2.0 high-speed interface functionality. Carefully follow the suggestions provided in the relative section 2.6.1 for schematic and layout design.
4. SIM interface: **VSIM**, **SIM_CLK**, **SIM_IO**, **SIM_RST** or **UIM_PWR**, **UIM_DATA**, **UIM_CLK**, **UIM_RESET** pins.
Accurate design is required to guarantee SIM card functionality reducing the risk of RF coupling. Carefully follow the suggestions provided in the relative section 2.5 for schematic and layout design.
5. SDIO interface: **SDIO_D0**, **SDIO_D1**, **SDIO_D2**, **SDIO_D3**, **SDIO_CLK**, **SDIO_CMD** pins.
Accurate design is required to guarantee SDIO interface functionality. Carefully follow the suggestions provided in the relative section 2.6.4 for schematic and layout design.
6. System functions: **RESET_N** or **PERST#**, **PWR_ON** pins.
Accurate design is required to guarantee that the voltage level is well defined during operation. Carefully follow the suggestions provided in the relative section 2.3 for schematic and layout design.
7. Other supplies: **V_BCKP** RTC supply and **V_INT** generic digital interfaces supply.
Accurate design is required to guarantee proper functionality. Follow the suggestions provided in the corresponding sections 2.2.2 and 2.2.3 for schematic and layout design.
8. Other digital interfaces: UART, I²C, I²S, Host Select, GPIOs, Mini PCIe specific signals and Reserved pins.
Accurate design is required to guarantee proper functionality. Follow the suggestions provided in sections 2.6.2, 2.6.3, 2.7.1, 2.3.3, 2.8, 2.9 and 2.10 for schematic and layout design.

2.2 Supply interfaces

2.2.1 Module supply (VCC or 3.3Vaux)

2.2.1.1 General guidelines for VCC or 3.3Vaux supply circuit selection and design

VCC or **3.3Vaux** pins are internally connected. Application design shall connect all the available pads to the external supply to minimize the power loss due to series resistance.

GND pins are internally connected. Application design shall connect all the available pads to solid ground on the application board, since a good (low impedance) connection to external ground can minimize power loss and improve RF and thermal performance.

TOBY-L2 and MPC1-L2 series modules must be sourced through the **VCC** or the **3.3Vaux** pins with a proper DC power supply that should meet the following prerequisites to comply with the modules' **VCC** or **3.3Vaux** requirements summarized in Table 7.

The proper DC power supply can be selected according to the application requirements (see Figure 31) between the different possible supply sources types, which most common ones are the following:

- Switching regulator
- Low Drop-Out (LDO) linear regulator
- Rechargeable Lithium-ion (Li-Ion) or Lithium-ion polymer (Li-Pol) battery, for TOBY-L2 series only
- Primary (disposable) battery, for TOBY-L2 series only

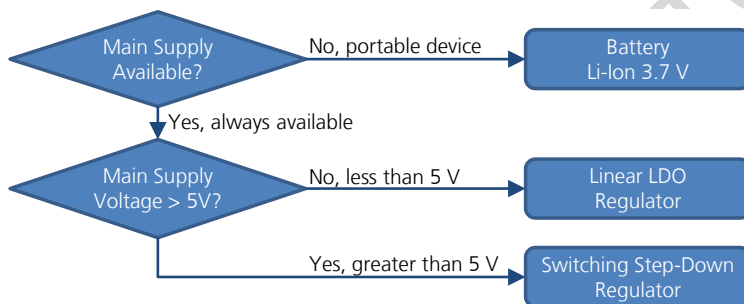

Figure 31: VCC supply concept selection

The switching step-down regulator is the typical choice when the available primary supply source has a nominal voltage much higher (e.g. greater than 5 V) than the operating supply voltage of TOBY-L2 and MPC1-L2 series. The use of switching step-down provides the best power efficiency for the overall application and minimizes current drawn from the main supply source. See 2.2.1.2, 2.2.1.6, 2.2.1.9, 2.2.1.10 for specific design-in.

The use of an LDO linear regulator becomes convenient for a primary supply with a relatively low voltage (e.g. less or equal than 5 V). In this case the typical 90% efficiency of the switching regulator diminishes the benefit of voltage step-down and no true advantage is gained in input current savings. On the opposite side, linear regulators are not recommended for high voltage step-down as they dissipate a considerable amount of energy in thermal power. See 2.2.1.3, 2.2.1.6, 2.2.1.9, 2.2.1.10 for specific design-in.

If TOBY-L2 modules are deployed in a mobile unit where no permanent primary supply source is available, then a battery will be required to provide **VCC**. A standard 3-cell Li-Ion or Li-Pol battery pack directly connected to **VCC** is the usual choice for battery-powered devices. During charging, batteries with Ni-MH chemistry typically reach a maximum voltage that is above the maximum rating for **VCC**, and should therefore be avoided. See 2.2.1.4, 2.2.1.6, 2.2.1.9, 2.2.1.10 for specific design-in.

Keep in mind that the use of rechargeable batteries requires the implementation of a suitable charger circuit which is not included in the modules. The charger circuit has to be designed to prevent over-voltage on **VCC** pins of the module, and it should be selected according to the application requirements: a DC/DC switching

charger is the typical choice when the charging source has an high nominal voltage (e.g. ~12 V), whereas a linear charger is the typical choice when the charging source has a relatively low nominal voltage (~5 V). If both a permanent primary supply / charging source (e.g. ~12 V) and a rechargeable back-up battery (e.g. 3.7 V Li-Pol) are available at the same time in the application as possible supply source, then a proper charger / regulator with integrated power path management function can be selected to supply the module while simultaneously and independently charging the battery. See 2.2.1.7, 2.2.1.8 and 2.2.1.6, 2.2.1.9, 2.2.1.10 for specific design-in.

The use of a primary (not rechargeable) battery is in general uncommon, but appropriate parts can be selected given that the most cells available are seldom capable of delivering the maximum current specified in TOBY-L2 series Data Sheet [1] during connected-mode. Carefully evaluate the usage of super-capacitors as supply source since aging and temperature conditions significantly affect the actual capacitor characteristics. See 2.2.1.5 and 2.2.1.6, 2.2.1.9, 2.2.1.10 for specific design-in.

Rechargeable 3-cell Li-Ion or Li-Pol and Ni-MH chemistry batteries reach a maximum voltage that is above the maximum rating for the **3.3Vaux** supply of MPC1-L2 modules, and should therefore be avoided. The use of rechargeable, not-rechargeable battery or super-capacitors is very uncommon for Mini PCI Express applications, so that these supply sources types are not considered for MPC1-L2 modules.

The usage of more than one DC supply at the same time should be carefully evaluated: depending on the supply source characteristics, different DC supply systems can result as mutually exclusive.

The following sections highlight some design aspects for each of the supplies listed above providing application circuit design-in compliant with the module **VCC** requirements summarized in Table 7.

2.2.1.2 Guidelines for VCC or 3.3Vaux supply circuit design using a switching regulator

The use of a switching regulator is suggested when the difference from the available supply rail to the **VCC** or the **3.3Vaux** value is high, since switching regulators provide good efficiency transforming a 12 V or greater voltage supply to the typical 3.8 V value of the **VCC** supply or the typical 3.3 V value of the **3.3Vaux** supply.

The characteristics of the switching regulator connected to **VCC** or **3.3Vaux** pins should meet the following prerequisites to comply with the module **VCC** or **3.3Vaux** requirements summarized in Table 7:

- **Power capability:** the switching regulator with its output circuit must be capable of providing a voltage value to the **VCC** or **3.3Vaux** pins within the specified operating range and must be capable of delivering to **VCC** or **3.3Vaux** pins the maximum peak / pulse current consumption during Tx burst at maximum Tx power specified in the TOBY-L2 series Data Sheet [1] or in the MPC1-L2 series Data Sheet [2].
- **Low output ripple:** the switching regulator together with its output circuit must be capable of providing a clean (low noise) **VCC** or **3.3Vaux** voltage profile.
- **High switching frequency:** for best performance and for smaller applications it is recommended to select a switching frequency ≥ 600 kHz (since L-C output filter is typically smaller for high switching frequency). The use of a switching regulator with a variable switching frequency or with a switching frequency lower than 600 kHz must be carefully evaluated since this can produce noise in the **VCC** or **3.3Vaux** voltage profile and therefore negatively impact LTE/3G/2G modulation spectrum performance. An additional L-C low-pass filter between the switching regulator output to **VCC** or **3.3Vaux** supply pins can mitigate the ripple at the input of the module, but adds extra voltage drop due to resistive losses on series inductors.
- **PWM mode operation:** it is preferable to select regulators with Pulse Width Modulation (PWM) mode. While in connected-mode, the Pulse Frequency Modulation (PFM) mode and PFM/PWM modes transitions must be avoided to reduce the noise on the **VCC** or **3.3Vaux** voltage profile. Switching regulators can be used that are able to switch between low ripple PWM mode and high ripple PFM mode, provided that the mode transition occurs when the module changes status from the idle/active-modes to connected-mode. It is permissible to use a regulator that switches from the PWM mode to the burst or PFM mode at an appropriate current threshold.

Figure 32 and Table 14 show an example of a high reliability power supply circuit, where the module **VCC** or **3.3Vaux** input is supplied by a step-down switching regulator capable of delivering maximum current with low output ripple and with fixed switching frequency in PWM mode operation greater than 1 MHz.

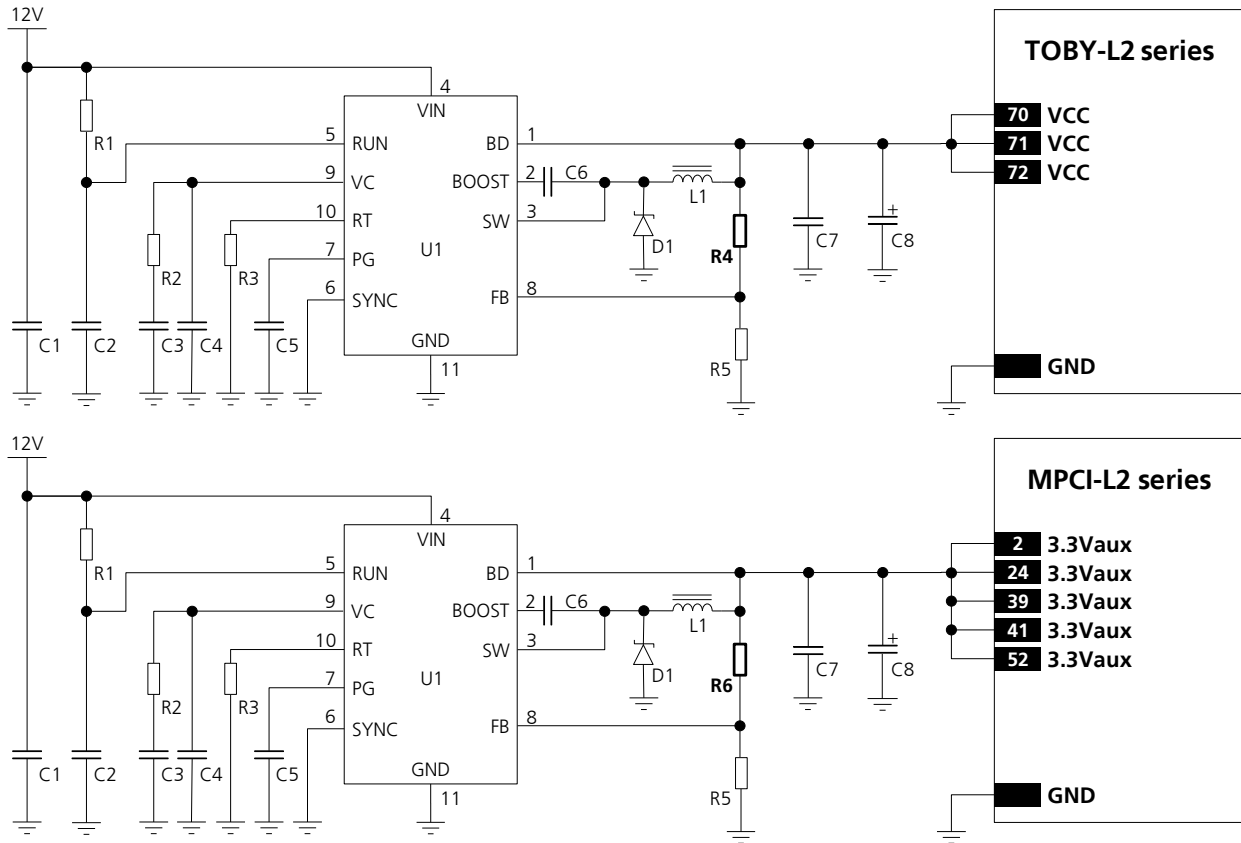

Figure 32: Example of high reliability VCC and 3.3Vaux supply application circuit using a step-down regulator

Reference	Description	Part Number - Manufacturer
C1	10 μ F Capacitor Ceramic X7R 5750 15% 50 V	C5750X7R1H106MB - TDK
C2	10 nF Capacitor Ceramic X7R 0402 10% 16 V	GRM155R71C103KA01 - Murata
C3	680 pF Capacitor Ceramic X7R 0402 10% 16 V	GRM155R71H681KA01 - Murata
C4	22 pF Capacitor Ceramic C0G 0402 5% 25 V	GRM1555C1H220JZ01 - Murata
C5	10 nF Capacitor Ceramic X7R 0402 10% 16 V	GRM155R71C103KA01 - Murata
C6	470 nF Capacitor Ceramic X7R 0603 10% 25 V	GRM188R71E474KA12 - Murata
C7	22 μ F Capacitor Ceramic X5R 1210 10% 25 V	GRM32ER61E226KE15 - Murata
C8	330 μ F Capacitor Tantalum D_SIZE 6.3 V 45 m Ω	T520D337M006ATE045 - KEMET
D1	Schottky Diode 40 V 3 A	MBRA340T3G - ON Semiconductor
L1	10 μ H Inductor 744066100 30% 3.6 A	744066100 - Würth Electronics
R1	470 k Ω Resistor 0402 5% 0.1 W	2322-705-87474-L - Yageo
R2	15 k Ω Resistor 0402 5% 0.1 W	2322-705-87153-L - Yageo
R3	22 k Ω Resistor 0402 5% 0.1 W	2322-705-87223-L - Yageo
R4	390 k Ω Resistor 0402 1% 0.063 W	RC0402FR-07390KL - Yageo
R5	100 k Ω Resistor 0402 5% 0.1 W	2322-705-70104-L - Yageo
R6	330 k Ω Resistor 0402 1% 0.063 W	RC0402FR-07330KL - Yageo
U1	Step-Down Regulator MSOP10 3.5 A 2.4 MHz	LT3972IMSE#PBF - Linear Technology

Table 14: Components for high reliability VCC and 3.3Vaux supply application circuit using a step-down regulator

Figure 33 and the components listed in Table 15 show an example of a low cost power supply circuit, where the **VCC** module supply is provided by a step-down switching regulator capable of delivering to **VCC** pins the specified maximum peak / pulse current, transforming a 12 V supply input.

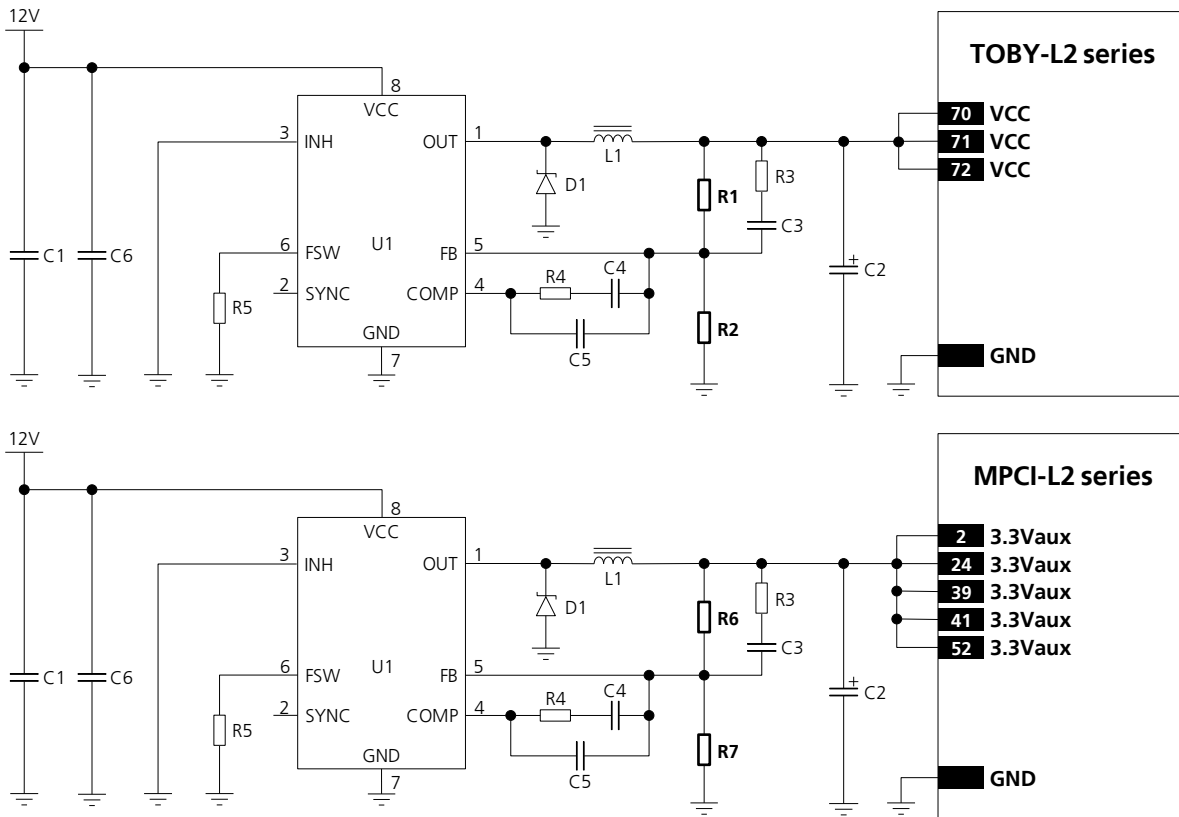

Figure 33: Example of low cost VCC and 3.3Vaux supply application circuit using step-down regulator

Reference	Description	Part Number - Manufacturer
C1	22 μ F Capacitor Ceramic X5R 1210 10% 25 V	GRM32ER61E226KE15 – Murata
C2	100 μ F Capacitor Tantalum B_SIZE 20% 6.3V 15m Ω	T520B107M006ATE015 – Kemet
C3	5.6 nF Capacitor Ceramic X7R 0402 10% 50 V	GRM155R71H562KA88 – Murata
C4	6.8 nF Capacitor Ceramic X7R 0402 10% 50 V	GRM155R71H682KA88 – Murata
C5	56 pF Capacitor Ceramic COG 0402 5% 50 V	GRM1555C1H560JA01 – Murata
C6	220 nF Capacitor Ceramic X7R 0603 10% 25 V	GRM188R71E224KA88 – Murata
D1	Schottky Diode 25V 2 A	STPS2L25 – STMicroelectronics
L1	5.2 μ H Inductor 30% 5.28A 22 m Ω	MSS1038-522NL – Coilcraft
R1	4.7 k Ω Resistor 0402 1% 0.063 W	RC0402FR-074K7L – Yageo
R2	910 Ω Resistor 0402 1% 0.063 W	RC0402FR-07910RL – Yageo
R3	82 Ω Resistor 0402 5% 0.063 W	RC0402JR-0782RL – Yageo
R4	8.2 k Ω Resistor 0402 5% 0.063 W	RC0402JR-078K2L – Yageo
R5	39 k Ω Resistor 0402 5% 0.063 W	RC0402JR-0739KL – Yageo
R6	1.5 k Ω Resistor 0402 1% 0.063 W	RC0402FR-071K5L – Yageo
R7	330 Ω Resistor 0402 1% 0.063 W	RC0402FR-07330RL – Yageo
U1	Step-Down Regulator 8-VFQFPN 3 A 1 MHz	L5987TR – ST Microelectronics

Table 15: Components for low cost VCC and 3.3Vaux supply application circuit using a step-down regulator

2.2.1.3 Guidelines for VCC or 3.3Vaux supply circuit design using a Low Drop-Out linear regulator

The use of a linear regulator is suggested when the difference from the available supply rail and the **VCC** or the **3.3Vaux** value is low. The linear regulators provide high efficiency when transforming a 5 VDC supply to a voltage value within the module **VCC** or **3.3Vaux** normal operating range.

The characteristics of the Low Drop-Out (LDO) linear regulator connected to **VCC** or **3.3Vaux** pins should meet the following prerequisites to comply with the module **VCC** or **3.3Vaux** requirements summarized in Table 7:

- **Power capabilities:** the LDO linear regulator with its output circuit must be capable of providing a voltage value to the **VCC** or **3.3Vaux** pins within the specified operating range and must be capable of delivering to **VCC** or **3.3Vaux** pins the maximum peak / pulse current consumption during Tx burst at maximum Tx power specified in TOBY-L2 series Data Sheet [1] or in MPC1-L2 series Data Sheet [2].
- **Power dissipation:** the power handling capability of the LDO linear regulator must be checked to limit its junction temperature to the maximum rated operating range (i.e. check the voltage drop from the max input voltage to the minimum output voltage to evaluate the power dissipation of the regulator).

Figure 34 and the components listed in Table 16 show an example of a power supply circuit, where the **VCC** or **3.3Vaux** module supply is provided by an LDO linear regulator capable of delivering the required current, with proper power handling capability.

It is recommended to configure the LDO linear regulator to generate a voltage supply value slightly below the maximum limit of the module **VCC** or **3.3Vaux** normal operating range (e.g. ~4.1 V for the **VCC** and ~3.44 V for the **3.3Vaux** as in the circuits described in Figure 34 and Table 16). This reduces the power on the linear regulator and improves the thermal design of the circuit.

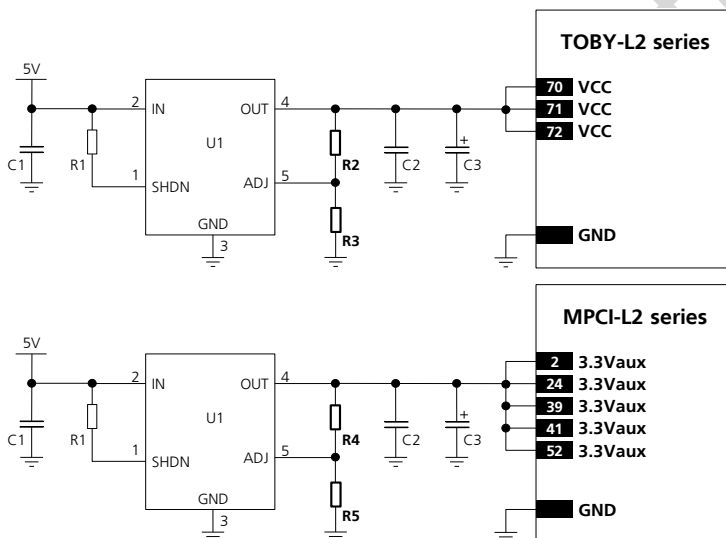

Figure 34: Suggested schematic design for the VCC and 3.3Vaux supply application circuit using an LDO linear regulator

Reference	Description	Part Number - Manufacturer
C1, C2	10 µF Capacitor Ceramic X5R 0603 20% 6.3 V	GRM188R60J106ME47 - Murata
C3	330 µF Capacitor Tantalum D_SIZE 6.3 V 45 mΩ	T520D337M006ATE045 - KEMET
R1	47 kΩ Resistor 0402 5% 0.1 W	RC0402JR-0747KL - Yageo Phycomp
R2	9.1 kΩ Resistor 0402 5% 0.1 W	RC0402JR-079K1L - Yageo Phycomp
R3	3.9 kΩ Resistor 0402 5% 0.1 W	RC0402JR-073K9L - Yageo Phycomp
R4	3.3 kΩ Resistor 0402 5% 0.1 W	RC0402JR-073K3L - Yageo Phycomp
R5	1.8 kΩ Resistor 0402 5% 0.1 W	RC0402JR-071K8L - Yageo Phycomp
U1	LDO Linear Regulator ADJ 3.0 A	LT1764AEQ#PBF - Linear Technology

Table 16: Suggested components for VCC and 3.3Vaux supply application circuit using an LDO linear regulator

Figure 35 and the components listed in Table 17 show an example of a low cost power supply circuit, where the **VCC** module supply is provided by an LDO linear regulator capable of delivering the specified highest peak / pulse current, with proper power handling capability. The regulator described in this example supports a limited input voltage range and it includes internal circuitry for current and thermal protection.

It is recommended to configure the LDO linear regulator to generate a voltage supply value slightly below the maximum limit of the module VCC normal operating range (e.g. ~4.1 V as in the circuit described in Figure 35 and Table 17). This reduces the power on the linear regulator and improves the whole thermal design of the supply circuit.

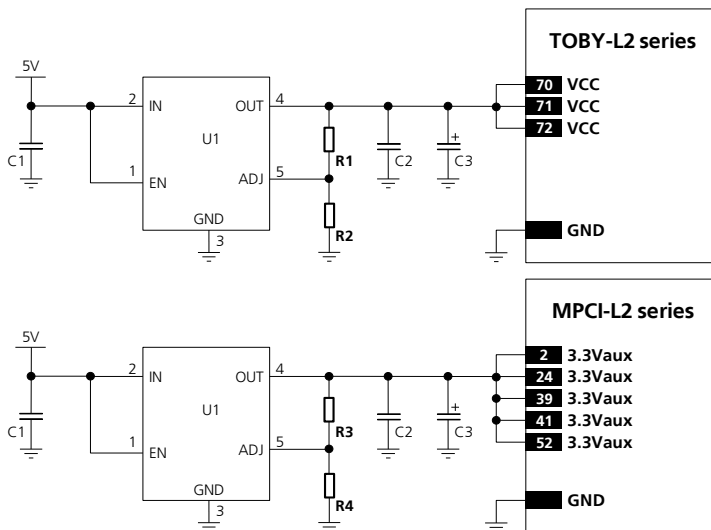

Figure 35: Suggested schematic design for the VCC and 3.3Vaux supply application circuit using an LDO linear regulator

Reference	Description	Part Number - Manufacturer
C1, C2	10 μ F Capacitor Ceramic X5R 0603 20% 6.3 V	GRM188R60J106ME47 - Murata
C3	330 μ F Capacitor Tantalum D_SIZE 6.3 V 45 m Ω	T520D337M006ATE045 - KEMET
R1	27 k Ω Resistor 0402 5% 0.1 W	RC0402JR-0727KL - Yageo Phycomp
R2	4.7 k Ω Resistor 0402 5% 0.1 W	RC0402JR-074K7L - Yageo Phycomp
R3	12 k Ω Resistor 0402 5% 0.1 W	RC0402JR-0712KL - Yageo Phycomp
R4	2.7 k Ω Resistor 0402 5% 0.1 W	RC0402JR-072K7L - Yageo Phycomp
U1	LDO Linear Regulator ADJ 3.0 A	LP38501ATJ-ADJ/NOPB - Texas Instrument

Table 17: Suggested components for VCC voltage supply application circuit using an LDO linear regulator

2.2.1.4 Guidelines for VCC supply circuit design using a rechargeable Li-Ion or Li-Pol battery

Rechargeable Li-Ion or Li-Pol batteries connected to the **VCC** pins should meet the following prerequisites to comply with the module **VCC** requirements summarized in Table 7:

- Maximum pulse and DC discharge current:** the rechargeable Li-Ion battery with its related output circuit connected to the **VCC** pins must be capable of delivering a pulse current as the maximum peak current consumption during Tx burst at maximum Tx power specified in TOBY-L2 series Data Sheet [1] and must be capable of extensively delivering a DC current as the maximum average current consumption specified in TOBY-L2 series Data Sheet [1]. The maximum discharge current is not always reported in battery data sheets, but the maximum DC discharge current is typically almost equal to the battery capacity in Amp-hours divided by 1 hour.
- DC series resistance:** the rechargeable Li-Ion battery with its output circuit must be capable of avoiding a VCC voltage drop below the operating range summarized in Table 7 during transmit bursts.

2.2.1.5 Guidelines for VCC supply circuit design using a primary (disposable) battery

The characteristics of a primary (non-rechargeable) battery connected to **VCC** pins should meet the following prerequisites to comply with the module **VCC** requirements summarized in Table 7:

- **Maximum pulse and DC discharge current:** the non-rechargeable battery with its related output circuit connected to the **VCC** pins must be capable of delivering a pulse current as the maximum peak current consumption during Tx burst at maximum Tx power specified in TOBY-L2 series Data Sheet [1] and must be capable of extensively delivering a DC current as the maximum average current consumption specified in TOBY-L2 series Data Sheet [1]. The maximum discharge current is not always reported in battery data sheets, but the maximum DC discharge current is typically almost equal to the battery capacity in Amp-hours divided by 1 hour.
- **DC series resistance:** the non-rechargeable battery with its output circuit must be capable of avoiding a VCC voltage drop below the operating range summarized in Table 7 during transmit bursts.

2.2.1.6 Additional guidelines for VCC or 3.3Vaux supply circuit design

To reduce voltage drops, use a low impedance power source. The series resistance of the power supply lines (connected to the modules' **VCC / 3.3Vaux** and **GND** pins) on the application board and battery pack should also be considered and minimized: cabling and routing must be as short as possible to minimize power losses.

Three pins are allocated to **VCC** supply and five pins to **3.3Vaux** supply. Several pins are designated for **GND** connection. Even if all the **VCC / 3.3Vaux** pins and all the **GND** pins are internally connected within the module, it is recommended to properly connect all of them to supply the module to minimize series resistance losses.

To avoid voltage drop undershoot and overshoot at the start and end of a transmit burst during a GSM call (when current consumption on the **VCC** or **3.3Vaux** supply can rise up as specified in TOBY-L2 series Data Sheet [1] or in MPC1-L2 series Data Sheet [2]), place a bypass capacitor with large capacitance (at least 100 μ F) and low ESR near the **VCC** pins, for example:

- 330 μ F capacitance, 45 m Ω ESR (e.g. KEMET T520D337M006ATE045, Tantalum Capacitor)

To reduce voltage ripple and noise, improving RF performance especially if the application device integrates an internal antenna, place the following bypass capacitors near the **VCC / 3.3Vaux** pins:

- 68 pF capacitor with Self-Resonant Frequency in the 800/900 MHz range (e.g. Murata GRM1555C1H680J) to filter EMI in the RF low frequencies bands
- 15 pF capacitor with Self-Resonant Frequency in 1800/1900 MHz range (e.g. Murata GRM1555C1E150J) to filter EMI in the RF high frequencies bands
- 8.2 pF capacitor with Self-Resonant Frequency in 2500/2600 MHz range (e.g. Murata GRM1555C1H8R2D) to filter EMI in the RF very high frequencies band
- 10 nF capacitor (e.g. Murata GRM155R71C103K) to filter digital logic noise from clocks and data sources
- 100 nF capacitor (e.g. Murata GRM155R61C104K) to filter digital logic noise from clocks and data sources

A suitable series ferrite bead can be properly placed on the **VCC / 3.3Vaux** line for additional noise filtering if required by the specific application according to the whole application board design.



The necessity of each part depends on the specific design, but it is recommended to provide all the bypass capacitors described in Figure 36 / Table 18 if the application device integrates an internal antenna.

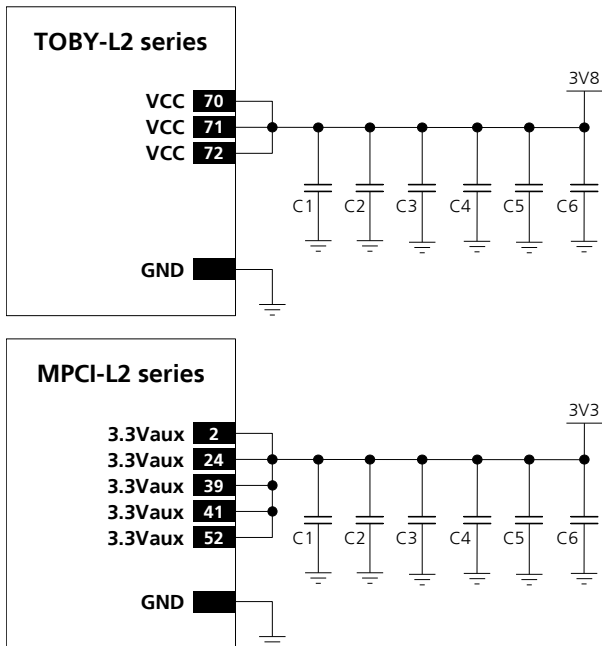

Figure 36: Suggested schematic for the VCC / 3.3Vaux bypass capacitors to reduce ripple / noise on supply voltage profile

Reference	Description	Part Number - Manufacturer
C1	68 pF Capacitor Ceramic C0G 0402 5% 50 V	GRM1555C1H680JA01 - Murata
C2	15 pF Capacitor Ceramic C0G 0402 5% 50 V	GRM1555C1H150JA01 - Murata
C3	8.2 pF Capacitor Ceramic C0G 0402 5% 50 V	GRM1555C1H8R2DZ01 - Murata
C4	10 nF Capacitor Ceramic X7R 0402 10% 16 V	GRM155R71C103KA01 - Murata
C5	100 nF Capacitor Ceramic X7R 0402 10% 16 V	GRM155R71C104KA01 - Murata
C6	330 μ F Capacitor Tantalum D_SIZE 6.3 V 45 m Ω	T520D337M006ATE045 - KEMET

Table 18: Suggested components to reduce ripple / noise on VCC / 3.3Vaux



ESD sensitivity rating of the **VCC / 3.3Vaux** supply pins is 1 kV (HBM according to JESD22-A114). Higher protection level can be required if the line is externally accessible on the application board, e.g. if accessible battery connector is directly connected to the supply pins. Higher protection level can be achieved by mounting an ESD protection (e.g. EPCOS CA05P4S14THSG varistor) close to accessible point.

2.2.1.7 Guidelines for external battery charging circuit

TOBY-L2 modules do not have an on-board charging circuit. Figure 37 provides an example of a battery charger design, suitable for applications that are battery powered with a Li-Ion (or Li-Polymer) cell.

In the application circuit, a rechargeable Li-Ion (or Li-Polymer) battery cell, that features proper pulse and DC discharge current capabilities and proper DC series resistance, is directly connected to the **VCC** supply input of TOBY-L2 module. Battery charging is completely managed by the STMicroelectronics L6924U Battery Charger IC that, from a USB power source (5.0 V typ.), charges as a linear charger the battery, in three phases:

- **Pre-charge constant current** (active when the battery is deeply discharged): the battery is charged with a low current, set to 10% of the fast-charge current
- **Fast-charge constant current**: the battery is charged with the maximum current, configured by the value of an external resistor to a value suitable for USB power source (~500 mA)
- **Constant voltage**: when the battery voltage reaches the regulated output voltage (4.2 V), the L6924U starts to reduce the current until the charge termination is done. The charging process ends when the charging current reaches the value configured by an external resistor to ~15 mA or when the charging timer reaches the value configured by an external capacitor to ~9800 s

Using a battery pack with an internal NTC resistor, the L6924U can monitor the battery temperature to protect the battery from operating under unsafe thermal conditions.

Alternatively the L6924U, providing input voltage range up to 12 V, can charge from an AC wall adapter. When a current-limited adapter is used, it can operate in quasi-pulse mode, reducing power dissipation.

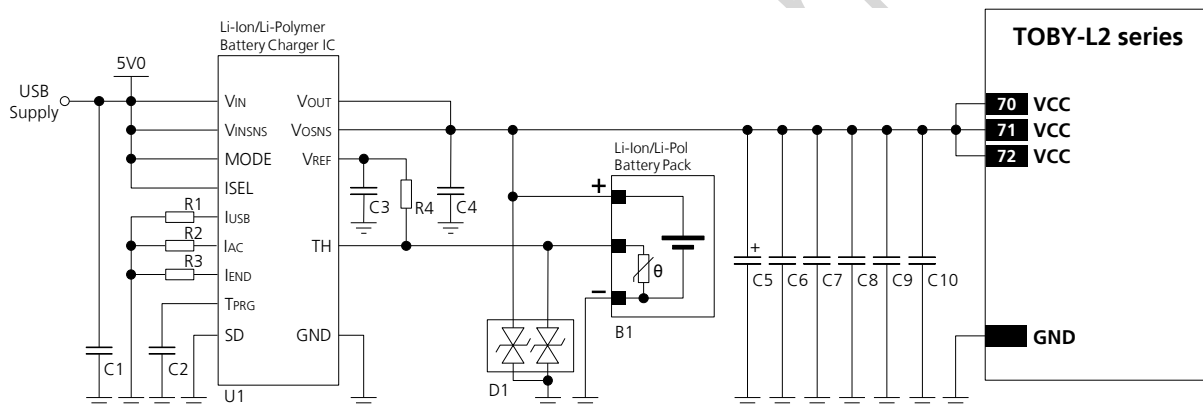

Figure 37: Li-Ion (or Li-Polymer) battery charging application circuit

Reference	Description	Part Number - Manufacturer
B1	Li-Ion (or Li-Polymer) battery pack with 470 Ω NTC	Various manufacturer
C1, C4	1 μF Capacitor Ceramic X7R 0603 10% 16 V	GRM188R71C105KA12 - Murata
C2, C6	10 nF Capacitor Ceramic X7R 0402 10% 16 V	GRM155R71C103KA01 - Murata
C3	1 nF Capacitor Ceramic X7R 0402 10% 50 V	GRM155R71H102KA01 - Murata
C5	330 μF Capacitor Tantalum D_SIZE 6.3 V 45 mΩ	T520D337M006ATE045 - KEMET
C7	100 nF Capacitor Ceramic X7R 0402 10% 16 V	GRM155R61A104KA01 - Murata
C8	68 pF Capacitor Ceramic COG 0402 5% 50 V	GRM1555C1H680JA01 - Murata
C9	15 pF Capacitor Ceramic COG 0402 5% 50 V	GRM1555C1H150JA01 - Murata
C10	8.2 pF Capacitor Ceramic COG 0402 5% 50 V	GRM1555C1H8R2DZ01 - Murata
D1	Low Capacitance ESD Protection	USB0002RP or USB0002DP - AVX
R1, R2	24 kΩ Resistor 0402 5% 0.1 W	RC0402JR-0724KL - Yageo Phycomp
R3	3.3 kΩ Resistor 0402 5% 0.1 W	RC0402JR-073K3L - Yageo Phycomp
R4	1.0 kΩ Resistor 0402 5% 0.1 W	RC0402JR-071K0L - Yageo Phycomp
U1	Single Cell Li-Ion (or Li-Polymer) Battery Charger IC	L6924U - STMicroelectronics

Table 19: Suggested components for Li-Ion (or Li-Polymer) battery charging application circuit

2.2.1.8 Guidelines for external battery charging and power path management circuit

Application devices where both a permanent primary supply / charging source (e.g. ~12 V) and a rechargeable back-up battery (e.g. 3.7 V Li-Pol) are available at the same time as possible supply source should implement a suitable charger / regulator with integrated power path management function to supply the module and the whole device while simultaneously and independently charging the battery.

Figure 38 reports a simplified block diagram circuit showing the working principle of a charger / regulator with integrated power path management function. This component allows the system to be powered by a permanent primary supply source (e.g. ~12 V) using the integrated regulator which simultaneously and independently recharges the battery (e.g. 3.7 V Li-Pol) that represents the back-up supply source of the system: the power path management feature permits the battery to supplement the system current requirements when the primary supply source is not available or cannot deliver the peak system currents.

A power management IC should meet the following prerequisites to comply with the module **VCC** requirements summarized in Table 7:

- High efficiency internal step down converter, compliant with the performances specified in section 2.2.1.2
- Low internal resistance in the active path $V_{out} - V_{bat}$, typically lower than 50 m Ω
- High efficiency switch mode charger with separate power path control

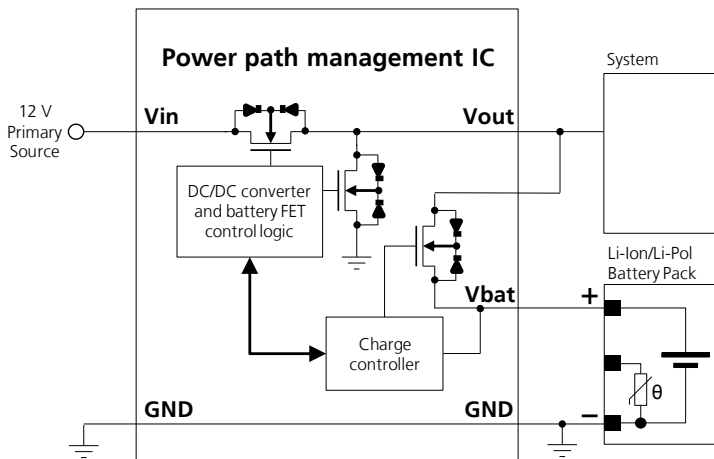

Figure 38: Charger / regulator with integrated power path management circuit block diagram

Figure 39 and the components listed in Table 20 provide an application circuit example where the MPS MP2617 switching charger / regulator with integrated power path management function provides the supply to the cellular module while concurrently and autonomously charging a suitable Li-Ion (or Li-Polymer) battery with proper pulse and DC discharge current capabilities and proper DC series resistance according to the rechargeable battery recommendations described in section 2.2.1.4.

The MP2617 IC constantly monitors the battery voltage and selects whether to use the external main primary supply / charging source or the battery as supply source for the module, and starts a charging phase accordingly.

The MP2617 IC normally provides a supply voltage to the module regulated from the external main primary source allowing immediate system operation even under missing or deeply discharged battery: the integrated switching step-down regulator is capable to provide up to 3 A output current with low output ripple and fixed 1.6 MHz switching frequency in PWM mode operation. The module load is satisfied in priority, then the integrated switching charger will take the remaining current to charge the battery.

Additionally, the power path control allows an internal connection from battery to the module with a low series internal ON resistance (40 m Ω typical), in order to supplement additional power to the module when the current demand increases over the external main primary source or when this external source is removed.

Battery charging is managed in three phases:

- **Pre-charge constant current** (active when the battery is deeply discharged): the battery is charged with a low current, set to 10% of the fast-charge current
- **Fast-charge constant current:** the battery is charged with the maximum current, configured by the value of an external resistor to a value suitable for the application
- **Constant voltage:** when the battery voltage reaches the regulated output voltage (4.2 V), the current is progressively reduced until the charge termination is done. The charging process ends when the charging current reaches the 10% of the fast-charge current or when the charging timer reaches the value configured by an external capacitor

Using a battery pack with an internal NTC resistor, the MP2617 can monitor the battery temperature to protect the battery from operating under unsafe thermal conditions.

Several parameters as the charging current, the charging timings, the input current limit, the input voltage limit, the system output voltage can be easily set according to the specific application requirements, as the actual electrical characteristics of the battery and the external supply / charging source: proper resistors or capacitors have to be accordingly connected to the related pins of the IC.

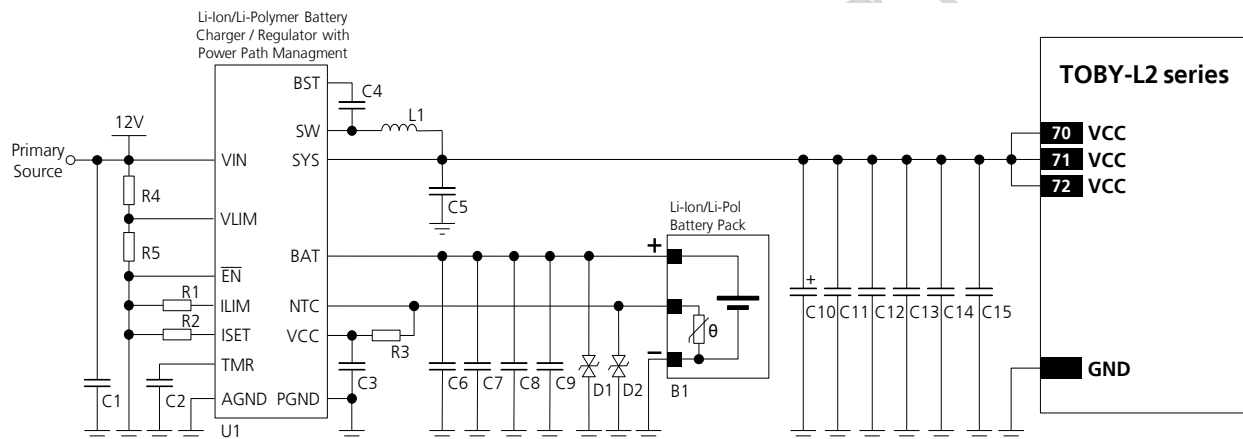

Figure 39: Li-Ion (or Li-Polymer) battery charging and power path management application circuit

Reference	Description	Part Number - Manufacturer
B1	Li-Ion (or Li-Polymer) battery pack with 10 k Ω NTC	Various manufacturer
C1, C5, C6	22 μ F Capacitor Ceramic X5R 1210 10% 25 V	GRM32ER61E226KE15 - Murata
C2, C4, C11	100 nF Capacitor Ceramic X7R 0402 10% 16 V	GRM155R61A104KA01 - Murata
C3	1 μ F Capacitor Ceramic X7R 0603 10% 25 V	GRM188R71E105KA12 - Murata
C7, C13	68 pF Capacitor Ceramic COG 0402 5% 50 V	GRM155C1H680JA01 - Murata
C8, C14	15 pF Capacitor Ceramic COG 0402 5% 25 V	GRM155C1E150JA01 - Murata
C9, C15	8.2 pF Capacitor Ceramic COG 0402 5% 50 V	GRM155C1H8R2DZ01 - Murata
C10	330 μ F Capacitor Tantalum D_SIZE 6.3 V 45 m Ω	T520D337M006ATE045 - KEMET
C12	10 nF Capacitor Ceramic X7R 0402 10% 16 V	GRM155R71C103KA01 - Murata
D1, D2	Low Capacitance ESD Protection	CG0402MLE-18G - Bourns
R1, R3, R5	10 k Ω Resistor 0402 5% 1/16 W	RC0402JR-0710KL - Yageo Phycomp
R2	1.0 k Ω Resistor 0402 5% 0.1 W	RC0402JR-071K0L - Yageo Phycomp
R4	22 k Ω Resistor 0402 5% 1/16 W	RC0402JR-0722KL - Yageo Phycomp
L1	1.2 μ H Inductor 6 A 21 m Ω 20%	7447745012 - Würth
U1	Li-Ion/Li-Polymer Battery DC/DC Charger / Regulator with integrated Power Path Management function	MP2617 - Monolithic Power Systems (MPS)

Table 20: Suggested components for Li-Ion (or Li-Polymer) battery charging and power path management application circuit

2.2.1.9 Guidelines for VCC or 3.3Vaux supply layout design

Good connection of the module **VCC** or **3.3Vaux** pins with DC supply source is required for correct RF performance. Guidelines are summarized in the following list:

- All the available **VCC** / **3.3Vaux** pins must be connected to the DC source
- **VCC** / **3.3Vaux** connection must be as wide as possible and as short as possible
- Any series component with Equivalent Series Resistance (ESR) greater than few milliohms must be avoided
- **VCC** / **3.3Vaux** connection must be routed through a PCB area separated from RF lines / parts, sensitive analog signals and sensitive functional units: it is good practice to interpose at least one layer of PCB ground between the **VCC** / **3.3Vaux** track and other signal routing
- Coupling between **VCC** / **3.3Vaux** and digital lines, especially USB, must be avoided.
- The tank bypass capacitor with low ESR for current spikes smoothing described in section 2.2.1.6 should be placed close to the **VCC** / **3.3Vaux** pins. If the main DC source is a switching DC-DC converter, place the large capacitor close to the DC-DC output and minimize **VCC** / **3.3Vaux** track length. Otherwise consider using separate capacitors for DC-DC converter and module tank capacitor
- The bypass capacitors in the pF range described in Figure 36 and Table 18 should be placed as close as possible to the **VCC** / **3.3Vaux** pins. This is highly recommended if the application device integrates an internal antenna
- Since **VCC** / **3.3Vaux** input provide the supply to RF Power Amplifiers, voltage ripple at high frequency may result in unwanted spurious modulation of transmitter RF signal. This is more likely to happen with switching DC-DC converters, in which case it is better to select the highest operating frequency for the switcher and add a large L-C filter before connecting to the TOBY-L2 and MPC1-L2 series modules in the worst case
- If **VCC** / **3.3Vaux** is protected by transient voltage suppressor to ensure that the voltage maximum ratings are not exceeded, place the protecting device along the path from the DC source toward the module, preferably closer to the DC source (otherwise protection functionality may be compromised)

2.2.1.10 Guidelines for grounding layout design

Good connection of the module **GND** pins with application board solid ground layer is required for correct RF performance. It significantly reduces EMC issues and provides a thermal heat sink for the module.

- Connect each **GND** pin with application board solid GND layer. It is strongly recommended that each **GND** pad surrounding **VCC** pins have one or more dedicated via down to the application board solid ground layer
- The **VCC** supply current flows back to main DC source through GND as ground current: provide adequate return path with suitable uninterrupted ground plane to main DC source
- It is recommended to implement one layer of the application board as ground plane as wide as possible
- If the application board is a multilayer PCB, then all the board layers should be filled with GND plane as much as possible and each GND area should be connected together with complete via stack down to the main ground layer of the board
- If the whole application device is composed by more than one PCB, then it is required to provide a good and solid ground connection between the GND areas of all the different PCBs
- Good grounding of **GND** pads also ensures thermal heat sink. This is critical during connection, when the real network commands the module to transmit at maximum power: proper grounding helps prevent module overheating.

2.2.2 RTC supply output (V_BCKP)



The RTC supply **V_BCKP** pin is not available on MPC1-L2 series modules.

2.2.2.1 Guidelines for V_BCKP circuit design

TOBY-L2 series modules provide the **V_BCKP** RTC supply input/output, which can be mainly used to:

- Provide RTC back-up when **VCC** supply is removed

If RTC timing is required to run for a time interval of T [s] when **VCC** supply is removed, place a capacitor with a nominal capacitance of C [μF] at the **V_BCKP** pin. Choose the capacitor using the following formula:

$$C [\mu\text{F}] = (\text{Current_Consumption} [\mu\text{A}] \times T [\text{s}]) / \text{Voltage_Drop} [\text{V}]$$

$$= 1.25 \times T [\text{s}]$$

For example, a 100 μF capacitor can be placed at **V_BCKP** to provide RTC backup holding the **V_BCKP** voltage within its valid range for around 80 s at 25 °C, after the **VCC** supply is removed. If a longer buffering time is required, a 70 mF super-capacitor can be placed at **V_BCKP**, with a 4.7 kΩ series resistor to hold the **V_BCKP** voltage within its valid range for approximately 15 hours at 25 °C, after the **VCC** supply is removed. The purpose of the series resistor is to limit the capacitor charging current due to the large capacitor specifications, and also to let a fast rise time of the voltage value at the **V_BCKP** pin after **VCC** supply has been provided. These capacitors allow the time reference to run during battery disconnection.

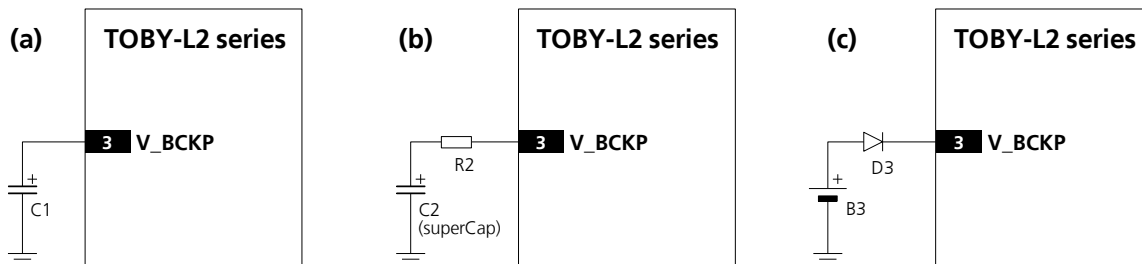

Figure 40: Real time clock supply (V_BCKP) application circuits: (a) using a 100 μF capacitor to let the RTC run for ~80 s after VCC removal; (b) using a 70 mF capacitor to let RTC run for ~15 hours after VCC removal; (c) using a non-rechargeable battery

Reference	Description	Part Number - Manufacturer
C1	100 μF Tantalum Capacitor	GRM43SR60J107M - Murata
R2	4.7 kΩ Resistor 0402 5% 0.1 W	RC0402JR-074K7L - Yageo Phycomp
C2	70 mF Capacitor	XH414H-IV01E - Seiko Instruments

Table 21: Example of components for V_BCKP buffering

If very long buffering time is required to allow the RTC time reference to run during a disconnection of the **VCC** supply, then an external battery can be connected to **V_BCKP** pin. The battery should be able to provide a proper nominal voltage and must never exceed the maximum operating voltage for **V_BCKP** (specified in the Input characteristics of Supply/Power pins table in TOBY-L2 series Data Sheet [1]). The connection of the battery to **V_BCKP** should be done with a suitable series resistor for a rechargeable battery, or with an appropriate series diode for a non-rechargeable battery. The purpose of the series resistor is to limit the battery charging current due to the battery specifications, and also to allow a fast rise time of the voltage value at the **V_BCKP** pin after the **VCC** supply has been provided. The purpose of the series diode is to avoid a current flow from the module **V_BCKP** pin to the non-rechargeable battery.



If the RTC timing is not required when the **VCC** supply is removed, it is not needed to connect the **V_BCKP** pin to an external capacitor or battery. In this case the date and time are not updated when **VCC** is disconnected. If **VCC** is always supplied, then the internal regulator is supplied from the main supply and there is no need for an external component on **V_BCKP**.

Combining a cellular module with a u-blox GNSS positioning receiver, the positioning receiver **VCC** supply is controlled by the cellular module by means of the "GNSS supply enable" function provided by the **GPIO2** of the cellular module. In this case the **V_BCKP** supply output of the cellular module can be connected to the **V_BCKP** backup supply input pin of the GNSS receiver to provide the supply for the positioning real time clock and backup RAM when the **VCC** supply of the cellular module is within its operating range and the **VCC** supply of the GNSS receiver is disabled. This enables the u-blox GNSS receiver to recover from a power breakdown with either a hot start or a warm start (depending on the duration of the positioning **VCC** outage) and to maintain the configuration settings saved in the backup RAM. See section 2.6.3 for more details regarding the application circuit with a u-blox GNSS receiver.

V_BCKP supply output pin provides internal short circuit protection to limit start-up current and protect the device in short circuit situations. No additional external short circuit protection is required.



Do not apply loads which might exceed the limit for maximum available current from **V_BCKP** supply (see TOBY-L2 series Data Sheet [1]) as this can cause malfunctions in internal circuitry.



ESD sensitivity rating of the **V_BCKP** supply pin is 1 kV (Human Body Model according to JESD22-A114). Higher protection level could be required if the line is externally accessible and it can be achieved by mounting an ESD protection (e.g. EPCOS CA05P4S14THSG varistor array) close to the accessible point.

2.2.2.2 Guidelines for **V_BCKP** layout design

V_BCKP supply requires careful layout: avoid injecting noise on this voltage domain as it may affect the stability of the internal circuitry.

2.2.3 Generic digital interfaces supply output (V_INT)

 The generic digital interfaces supply **V_INT** pin is not available on MPC1-L2 series modules.

2.2.3.1 Guidelines for V_INT circuit design

TOBY-L2 series provide the **V_INT** generic digital interfaces 1.8 V supply output, which can be mainly used to:

- Indicate when the module is switched on (as described in sections 1.6.1, 1.6.2)
- Pull-up SIM detection signal (see section 2.5 for more details)
- Supply voltage translators to connect 1.8 V module generic digital interfaces to 3.0 V devices (e.g. see 2.6.2)
- Pull-up DDC (I²C) interface signals (see section 2.6.3 for more details)
- Supply a 1.8 V u-blox 6 or subsequent u-blox GNSS receiver generation (see section 2.6.3 for more details)

V_INT supply output pin provides internal short circuit protection to limit start-up current and protect the device in short circuit situations. No additional external short circuit protection is required.

 Do not apply loads which might exceed the limit for maximum available current from **V_INT** supply (see the TOBY-L2 series Data Sheet [1]) as this can cause malfunctions in internal circuitry.

 Since the **V_INT** supply is generated by an internal switching step-down regulator, the **V_INT** voltage ripple can range as specified in the TOBY-L2 series Data Sheet [1]: it is not recommended to supply sensitive analog circuitry without adequate filtering for digital noise.

 **V_INT** can only be used as an output: do not connect any external supply source on **V_INT**.

 ESD sensitivity rating of the **V_INT** supply pin is 1 kV (Human Body Model according to JESD22-A114). Higher protection level could be required if the line is externally accessible and it can be achieved by mounting an ESD protection (e.g. EPCOS CA05P4S14THSG varistor array) close to the accessible point.

 It is recommended to provide direct access to the **V_INT** pin on the application board by means of an accessible test point directly connected to the **V_INT** pin.

2.2.3.2 Guidelines for V_INT layout design

V_INT supply output is generated by an integrated switching step-down converter. Because of this, it can be a source of noise: avoid coupling with sensitive signals.

2.3 System functions interfaces

2.3.1 Module power-on (PWR_ON)

The **PWR_ON** input pin is not available on MPC1-L2 series modules.

2.3.1.1 Guidelines for PWR_ON circuit design

TOBY-L2 series **PWR_ON** input is equipped with an internal active pull-up resistor to the **VCC** module supply as described in Figure 41: an external pull-up resistor is not required and should not be provided.

If connecting the **PWR_ON** input to a push button, the pin will be externally accessible on the application device. According to EMC/ESD requirements of the application, an additional ESD protection should be provided close to the accessible point, as described in Figure 41 and Table 22.

ESD sensitivity rating of the **PWR_ON** pin is 1 kV (Human Body Model according to JESD22-A114). Higher protection level can be required if the line is externally accessible on the application board, e.g. if an accessible push button is directly connected to **PWR_ON** pin, and it can be achieved by mounting an ESD protection (e.g. EPCOS CA05P4S14THSG varistor) close to the accessible point.

An open drain or open collector output is suitable to drive the **PWR_ON** input from an application processor as **PWR_ON** input is equipped with an internal active pull-up resistor to the **VCC** supply, as described in Figure 41.

A compatible push-pull output of an application processor can also be used. In any case, take care to set the proper level in all the possible scenarios to avoid an inappropriate module switch-on.

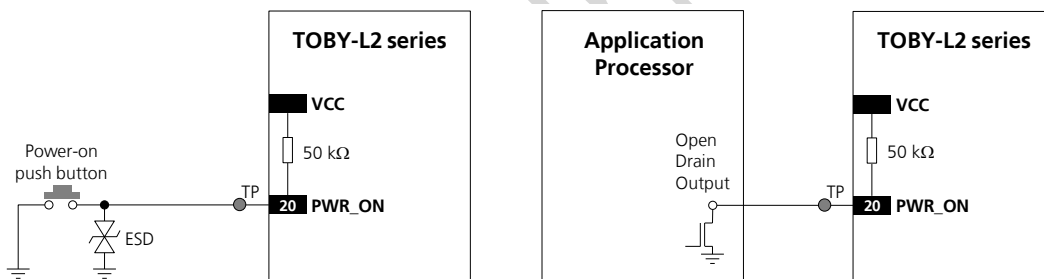

Figure 41: PWR_ON application circuits using a push button and an open drain output of an application processor

Reference	Description	Remarks
ESD	CT0402S14AHSG - EPCOS	Varistor array for ESD protection

Table 22: Example ESD protection component for the PWR_ON application circuit

It is recommended to provide direct access to the **PWR_ON** pin on the application board by means of an accessible test point directly connected to the **PWR_ON** pin.

2.3.1.2 Guidelines for PWR_ON layout design

The power-on circuit (**PWR_ON**) requires careful layout since it is the sensitive input available to switch on the TOBY-L2 modules. It is required to ensure that the voltage level is well defined during operation and no transient noise is coupled on this line, otherwise the module might detect a spurious power-on request.

2.3.2 Module reset (RESET_N or PERST#)

2.3.2.1 Guidelines for RESET_N and PERST# circuit design

The TOBY-L2 series **RESET_N** is equipped with an internal pull-up to the **VCC** supply and the MPC1-L2 series **PERST#** is equipped with an internal pull-up to the 3.3 V rail, as described in Figure 42. An external pull-up resistor is not required and should not be provided.

If connecting the **RESET_N** or **PERST#** input to a push button, the pin will be externally accessible on the application device. According to EMC/ESD requirements of the application, an additional ESD protection device (e.g. the EPCOS CA05P4S14THSG varistor) should be provided close to accessible point on the line connected to this pin, as described in Figure 42 and Table 23.



ESD sensitivity rating of the **RESET_N** and **PERST#** pins is 1 kV (HBM according to JESD22-A114). Higher protection level can be required if the line is externally accessible on the application board, e.g. if an accessible push button is directly connected to the **RESET_N** or **PERST#** pin, and it can be achieved by mounting an ESD protection (e.g. EPCOS CA05P4S14THSG varistor) close to accessible point.

An open drain output is suitable to drive the **RESET_N** and **PERST#** inputs from an application processor as they are equipped with an internal pull-up to **VCC** supply and to the 3.3 V rail respectively, as described in Figure 42.

A compatible push-pull output of an application processor can also be used. In any case, take care to set the proper level in all the possible scenarios to avoid an inappropriate module reset, switch-on or switch-off.

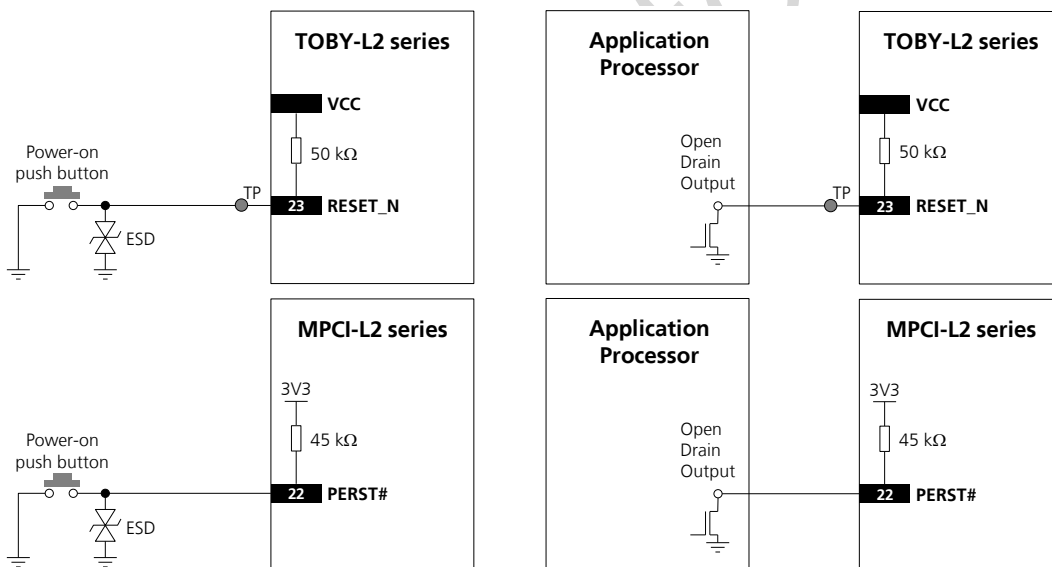

Figure 42: RESET_N and PERST# application circuits using a push button and an open drain output of an application processor

Reference	Description	Remarks
ESD	Varistor for ESD protection	CT0402S14AHSG - EPCOS

Table 23: Example of ESD protection component for the RESET_N and PERST# application circuits



If the external reset function is not required by the customer application, the **RESET_N** input pin can be left unconnected to external components, but it is recommended providing direct access on the application board by means of an accessible test point directly connected to the **RESET_N** pin.

2.3.2.2 Guidelines for RESET_N and PERST# layout design

The **RESET_N** and **PERST#** circuits require careful layout due to the pin function: ensure that the voltage level is well defined during operation and no transient noise is coupled on this line, otherwise the module might detect a spurious reset request. It is recommended to keep the connection line to **RESET_N** and **PERST#** pins as short as possible.

2.3.3 Module configuration selection by host processor



The **HOST_SELECT0** and **HOST_SELECT1** pins are not available on MPC1-L2 series modules.

2.3.3.1 Guidelines for HOST_SELECTx circuit design



The functionality of the **HOST_SELECT0** and **HOST_SELECT1** pins is not supported by the TOBY-L2 "00", "01", and "50" product versions: the two input pins should not be driven by the host application processor or any other external device.

TOBY-L2 series modules include two input pins (**HOST_SELECT0** and **HOST_SELECT1**) for the selection of the module configuration by the host application processor.



Guidelines for **HOST_SELECT0** and **HOST_SELECT1** pins circuit design will be described in detail in a successive release of the document.



Do not apply voltage to **HOST_SELECT0** and **HOST_SELECT1** pins before the switch-on of their supply source (**V_INT**), to avoid latch-up of circuits and allow a proper boot of the module. If the external signals connected to the cellular module cannot be tri-stated or set low, insert a multi channel digital switch (e.g. TI SN74CB3Q16244, TS5A3159, or TS5A63157) between the two-circuit connections and set to high impedance before **V_INT** switch-on.



ESD sensitivity rating of the **HOST_SELECT0** and **HOST_SELECT1** pins is 1 kV (HBM as per JESD22-A114). Higher protection level could be required if the lines are externally accessible and it can be achieved by mounting an ESD protection (e.g. EPCOS CA05P4S14THSG varistor array) close to accessible points



If the **HOST_SELECT0** and **HOST_SELECT1** pins are not used, they can be left unconnected on the application board.

2.3.3.2 Guidelines for HOST_SELECTx layout design

The input pins for the selection of the module configuration by the host application processor (**HOST_SELECT0** and **HOST_SELECT1**) are generally not critical for layout.

2.4 Antenna interface

TOBY-L2 and MPC1-L2 series modules provide two RF interfaces for connecting the external antennas:

- The **ANT1** pin represents the primary RF input/output for LTE/3G/2G RF signals transmission and reception.
- The **ANT2** pin represents the secondary RF input for LTE MIMO 2 x 2 or 3G Rx diversity RF signals reception.

Both the **ANT1** and the **ANT2** pins have a nominal characteristic impedance of 50 Ω and must be connected to the related antenna through a 50 Ω transmission line to allow proper transmission / reception of RF signals.



Two antennas (one connected to **ANT1** pin and one connected to **ANT2** pin) must be used to support the Down-Link MIMO 2 x 2 radio technology. This is a required feature for LTE category 4 User Equipments (up to 150 Mb/s Down-Link data rate) according to 3GPP specifications.

2.4.1 Antenna RF interfaces (ANT1 / ANT2)

2.4.1.1 General guidelines for antenna selection and design

The antenna is the most critical component to be evaluated. Designers must take care of the antennas from all perspective at the very start of the design phase when the physical dimensions of the application board are under analysis/decision, since the RF compliance of the device integrating TOBY-L2 and MPC1-L2 series modules with all the applicable required certification schemes depends on antennas radiating performance.

LTE/3G/2G antennas are typically available in the types of linear monopole or PCB antennas such as patches or ceramic SMT elements.

- External antennas (e.g. linear monopole)
 - External antennas basically do not imply physical restriction to the design of the PCB where the TOBY-L2 and MPC1-L2 series module is mounted.
 - The radiation performance mainly depends on the antennas. It is required to select antennas with optimal radiating performance in the operating bands.
 - RF cables should be carefully selected to have minimum insertion losses. Additional insertion loss will be introduced by low quality or long cable. Large insertion loss reduces both transmit and receive radiation performance.
 - A high quality 50 Ω RF connector provides proper PCB-to-RF-cable transition. It is recommended to strictly follow the layout and cable termination guidelines provided by the connector manufacturer.
- Integrated antennas (e.g. patch-like antennas):

- Internal integrated antennas imply physical restriction to the design of the PCB:

Integrated antenna excites RF currents on its counterpoise, typically the PCB ground plane of the device that becomes part of the antenna: its dimension defines the minimum frequency that can be radiated. Therefore, the ground plane can be reduced down to a minimum size that should be similar to the quarter of the wavelength of the minimum frequency that has to be radiated, given that the orientation of the ground plane relative to the antenna element must be considered.

The isolation between the primary and the secondary antennas has to be as high as possible and the correlation between the 3D radiation patterns of the two antennas has to be as low as possible. In general, a separation of at least a quarter wavelength between the two antennas is required to achieve a good isolation and low pattern correlation.

As numerical example, the physical restriction to the PCB design can be considered as following:

$$\text{Frequency} = 750 \text{ MHz} \rightarrow \text{Wavelength} = 40 \text{ cm} \rightarrow \text{Minimum GND plane size} = 10 \text{ cm}$$

- Radiation performance depends on the whole PCB and antenna system design, including product mechanical design and usage. Antennas should be selected with optimal radiating performance in the operating bands according to the mechanical specifications of the PCB and the whole product.
- It is recommended to select a pair of custom antennas designed by an antennas' manufacturer if the required ground plane dimensions are very small (e.g. less than 6.5 cm long and 4 cm wide). The antenna design process should begin at the start of the whole product design process
- It is highly recommended to strictly follow the detailed and specific guidelines provided by the antenna manufacturer regarding correct installation and deployment of the antenna system, including PCB layout and matching circuitry
- Further to the custom PCB and product restrictions, antennas may require tuning to obtain the required performance for compliance with all the applicable required certification schemes. It is recommended to consult the antenna manufacturer for the design-in guidelines for antenna matching relative to the custom application

In both of cases, selecting external or internal antennas, these recommendations should be observed:

- Select antennas providing optimal return loss (or V.S.W.R.) figure over all the operating frequencies.
- Select antennas providing optimal efficiency figure over all the operating frequencies.
- Select antennas providing similar efficiency for both the primary (**ANT1**) and the secondary (**ANT2**) antenna.
- Select antennas providing appropriate gain figure (i.e. combined antenna directivity and efficiency figure) so that the electromagnetic field radiation intensity do not exceed the regulatory limits specified in some countries (e.g. by FCC in the United States, as reported in the section 4.2.2).
- Select antennas capable to provide low Envelope Correlation Coefficient between the primary (**ANT1**) and the secondary (**ANT2**) antenna: the 3D antenna radiation patterns should have lobes in different directions.

2.4.1.2 Guidelines for antenna RF interface design

Guidelines for TOBY-L2 series ANT1 / ANT2 pins RF connection design

Proper transition between **ANT1 / ANT2** pads and the application board PCB must be provided, implementing the following design-in guidelines for the layout of the application PCB close to the **ANT1 / ANT2** pads:

- On a multilayer board, the whole layer stack below the RF connection should be free of digital lines
- Increase GND keep-out (i.e. clearance, a void area) around the **ANT1 / ANT2** pads, on the top layer of the application PCB, to at least 250 μm up to adjacent pads metal definition and up to 400 μm on the area below the module, to reduce parasitic capacitance to ground, as described in the left picture in Figure 43
- Add GND keep-out (i.e. clearance, a void area) on the buried metal layer below the **ANT1 / ANT2** pads if the top-layer to buried layer dielectric thickness is below 200 μm , to reduce parasitic capacitance to ground, as described in the right picture in Figure 43

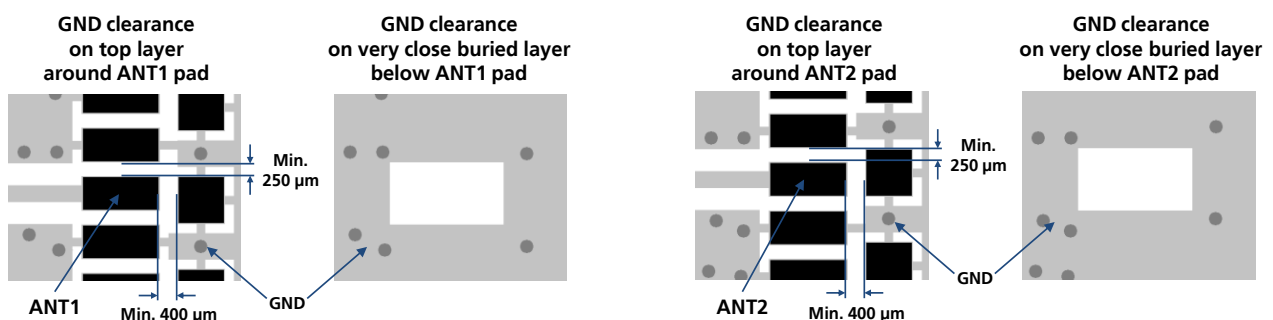

Figure 43: GND keep-out area on top layer around **ANT1 / ANT2** pads and on very close buried layer below **ANT1 / ANT2** pads

Guidelines for MPC1-L2 series ANT1 / ANT2 receptacles RF connection design

The Hirose U.FL-R-SMT RF receptacles implemented on the MPC1-L2 series modules for **ANT1 / ANT2** ports require a suitable mated RF plug from the same connector series. Due to its wide usage in the industry, several manufacturers offer compatible equivalents.

Table 24 lists some RF connector plugs that fit MPC1-L2 series modules RF connector receptacles, based on the declaration of the respective manufacturers. Only the Hirose has been qualified for the MPC1-L2 series modules; contact other producers to verify compatibility.

Manufacturer	Series	Remarks
Hirose	U.FL® Ultra Small Surface Mount Coaxial Connector	Recommended
I-PEX	MHF® Micro Coaxial Connector	
Tyco	UMCC® Ultra-Miniature Coax Connector	
Amphenol RF	AMC® Amphenol Micro Coaxial	
Lighthouse Technologies, Inc	IPX ultra micro-miniature RF connector	

Table 24: MPC1-L2 series U.FL compatible plug connector

Typically the RF plug is available as a cable assembly: several kinds are available and the user should select the cable assembly best suited to the application. The key characteristics are:

- RF plug type: select U.FL or equivalent
- Nominal impedance: 50 Ω
- Cable thickness: typically from 0.8 mm to 1.37 mm. Select thicker cables to minimize insertion loss
- Cable length: standard length is typically 100 mm or 200 mm, custom lengths may be available on request. Select shorter cables to minimize insertion loss
- RF connector on the other side of the cable: for example another U.FL (for board-to-board connection) or SMA (for panel mounting)

For applications requiring an internal integrated SMT antenna, it is suggested to use a U.FL-to-U.FL cable to provide RF path from the MPC1-L2 series module to PCB strip line or micro strip connected to antenna pads as shown in Figure 44. Take care that the PCB-to-RF-cable transition, strip line and antenna pads must be designed so that the characteristic impedance is as close as possible to 50 Ω : see the following subsections for specific guidelines regarding RF transmission line design and RF termination design.

If an external antenna is required, consider that the connector is typically rated for a limited number of insertion cycles. In addition, the RF coaxial cable may be relatively fragile compared to other types of cables. To increase application ruggedness, connect U.FL to a more robust connector (e.g. SMA or MMCX) fixed on panel or on flange as shown in Figure 44.

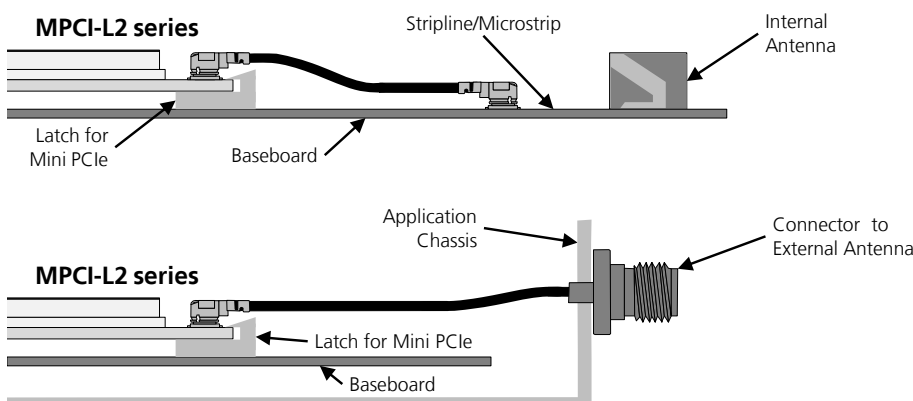

Figure 44: Example of RF connections, U.FL-to-U.FL cable for internal antenna and U.FL-to-SMA for external antenna

Guidelines for RF transmission line design

Any RF transmission line, such as the ones from the **ANT1** and **ANT2** pads up to the related antenna connector or up to the related internal antenna pad, must be designed so that the characteristic impedance is as close as possible to 50 Ω .

RF transmission lines can be designed as a micro strip (consists of a conducting strip separated from a ground plane by a dielectric material) or a strip line (consists of a flat strip of metal which is sandwiched between two parallel ground planes within a dielectric material). The micro strip, implemented as a coplanar waveguide, is the most common configuration for printed circuit board.

Figure 45 and Figure 46 provide two examples of proper 50 Ω coplanar waveguide designs. The first example of RF transmission line can be implemented in case of 4-layer PCB stack-up herein described, and the second example of RF transmission line can be implemented in case of 2-layer PCB stack-up herein described.

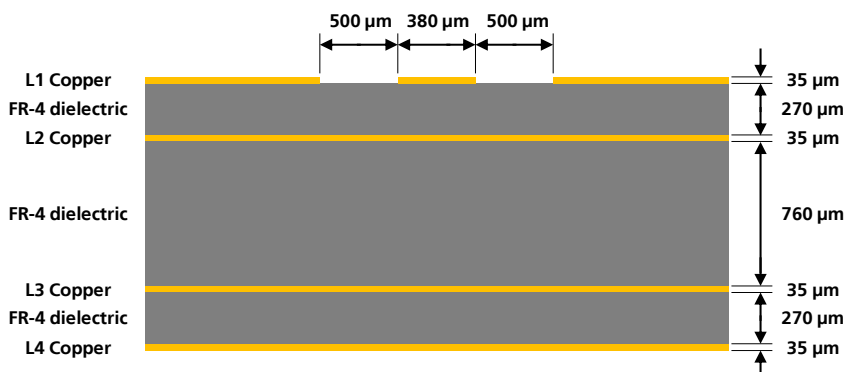

Figure 45: Example of 50 Ω coplanar waveguide transmission line design for the described 4-layer board layout

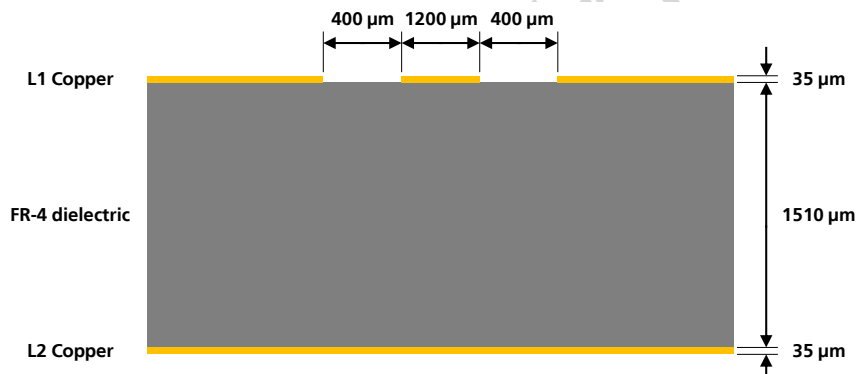

Figure 46: Example of 50 Ω coplanar waveguide transmission line design for the described 2-layer board layout

If the two examples do not match the application PCB stack-up the 50 Ω characteristic impedance calculation can be made using the HFSS commercial finite element method solver for electromagnetic structures from Ansys Corporation, or using freeware tools like AppCAD from Agilent (www.agilent.com) or TXLine from Applied Wave Research (www.mwoffice.com), taking care of the approximation formulas used by the tools for the impedance computation.

To achieve a 50 Ω characteristic impedance, the width of the transmission line must be chosen depending on:

- the thickness of the transmission line itself (e.g. 35 μm in the example of Figure 45 and Figure 46)
- the thickness of the dielectric material between the top layer (where the transmission line is routed) and the inner closer layer implementing the ground plane (e.g. 270 μm in Figure 45, 1510 μm in Figure 46)
- the dielectric constant of the dielectric material (e.g. dielectric constant of the FR-4 dielectric material in Figure 45 and Figure 46)

- the gap from the transmission line to the adjacent ground plane on the same layer of the transmission line (e.g. 500 μm in Figure 45, 400 μm in Figure 46)

If the distance between the transmission line and the adjacent GND area (on the same layer) does not exceed 5 times the track width of the micro strip, use the “Coplanar Waveguide” model for the 50 Ω calculation.

Additionally to the 50 Ω impedance, the following guidelines are recommended for transmission lines design:

- Minimize the transmission line length: the insertion loss should be minimized as much as possible, in the order of a few tenths of a dB,
- Add GND keep-out (i.e. clearance, a void area) on buried metal layers below any pad of component present on the RF transmission lines, if top-layer to buried layer dielectric thickness is below 200 μm , to reduce parasitic capacitance to ground,
- The transmission lines width and spacing to GND must be uniform and routed as smoothly as possible: avoid abrupt changes of width and spacing to GND,
- Add GND stitching vias around transmission lines, as described in Figure 47,
- Ensure solid metal connection of the adjacent metal layer on the PCB stack-up to main ground layer, providing enough vias on the adjacent metal layer, as described in Figure 47,
- Route RF transmission lines far from any noise source (as switching supplies and digital lines) and from any sensitive circuit (as USB),
- Avoid stubs on the transmission lines,
- Avoid signal routing in parallel to transmission lines or crossing the transmission lines on buried metal layer,
- Do not route microstrip lines below discrete component or other mechanics placed on top layer

An example of proper RF circuit design is reported in Figure 47. In this case, the **ANT1** and **ANT2** pins are directly connected to SMA connectors by means of proper 50 Ω transmission lines, designed with proper layout.

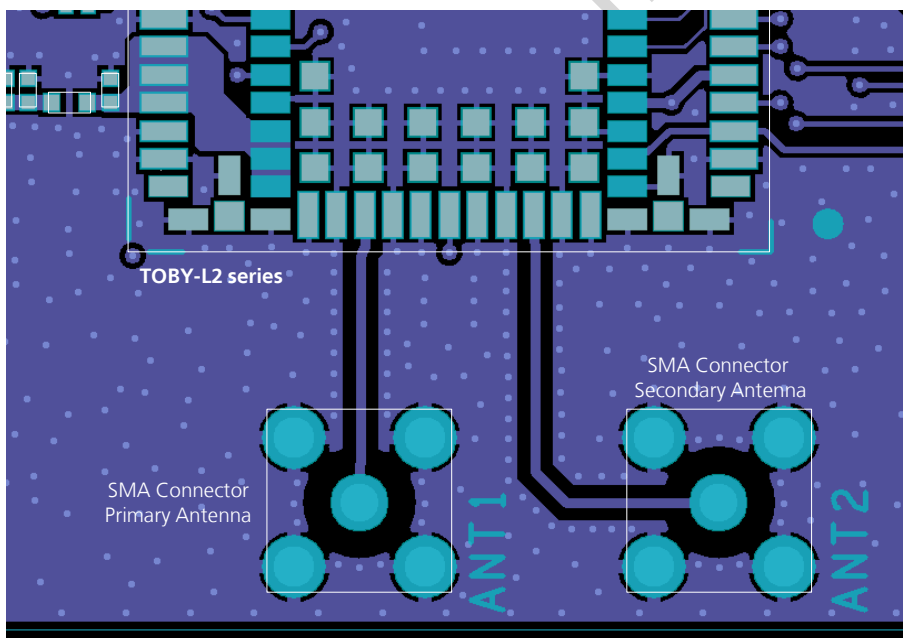

Figure 47: Suggested circuit and layout for antenna RF circuits on application board

Guidelines for RF termination design

RF terminations must provide a characteristic impedance of $50\ \Omega$ as well as the RF transmission lines up to the RF terminations themselves, to match the characteristic impedance of the **ANT1** / **ANT2** ports of the modules.

However, real antennas do not have perfect $50\ \Omega$ load on all the supported frequency bands. Therefore, to reduce as much as possible performance degradation due to antennas mismatch, RF terminations must provide optimal return loss (or V.S.W.R.) figure over all the operating frequencies, as summarized in Table 8 and Table 9.

If external antennas are used, the antenna connectors represent the RF termination on the PCB:

- Use suitable $50\ \Omega$ connectors providing proper PCB-to-RF-cable transition.
- Strictly follow the connector manufacturer's recommended layout, for example:
 - SMA Pin-Through-Hole connectors require GND keep-out (i.e. clearance, a void area) on all the layers around the central pin up to annular pads of the four GND posts, as shown in Figure 47
 - U.FL surface mounted connectors require no conductive traces (i.e. clearance, a void area) in the area below the connector between the GND land pads.
- Cut out the GND layer under RF connectors and close to buried vias, to remove stray capacitance and thus keep the RF line $50\ \Omega$, e.g. the active pad of UFL connectors needs to have a GND keep-out (i.e. clearance, a void area) at least on first inner layer to reduce parasitic capacitance to ground.

If integrated antennas are used, the RF terminations are represented by the integrated antennas themselves. The following guidelines should be followed:

- Use antennas designed by an antenna manufacturer, providing the best possible return loss (or V.S.W.R.).
- Provide a ground plane large enough according to the relative integrated antenna requirements. The ground plane of the application PCB can be reduced down to a minimum size that must be similar to one quarter of wavelength of the minimum frequency that has to be radiated. As numerical example,

Frequency = 750 MHz → Wavelength = 40 cm → Minimum GND plane size = 10 cm
- It is highly recommended to strictly follow the detailed and specific guidelines provided by the antenna manufacturer regarding correct installation and deployment of the antenna system, including PCB layout and matching circuitry.
- Further to the custom PCB and product restrictions, antennas may require a tuning to comply with all the applicable required certification schemes. It is recommended to consult the antenna manufacturer for the design-in guidelines for the antenna matching relative to the custom application.

Additionally, these recommendations regarding the antenna system placement must be followed:

- Do not place antennas within closed metal case.
- Do not place the antennas in close vicinity to end user since the emitted radiation in human tissue is limited by regulatory requirements.
- Place the antennas far from sensitive analog systems or employ countermeasures to reduce EMC issues.
- Take care of interaction between co-located RF systems since the LTE/3G/2G transmitted power may interact or disturb the performance of companion systems.
- Place the two LTE/3G antennas providing low Envelope Correlation Coefficient (ECC) between primary (**ANT1**) and secondary (**ANT2**) antenna: the antenna 3D radiation patterns should have lobes in different directions. The ECC between primary and secondary antenna needs to be enough low to comply with the radiated performance requirements specified by related certification schemes, as indicated in Table 10.
- Place the two LTE/3G antennas providing enough high isolation (see Table 10) between primary (**ANT1**) and secondary (**ANT2**) antenna. The isolation depends on the distance between antennas (separation of at least a quarter wavelength required for good isolation), antenna type (using antennas with different polarization improves isolation), antenna 3D radiation patterns (uncorrelated patterns improve isolation).

Examples of antennas

Table 25 lists some examples of possible internal on-board surface-mount antennas.

Manufacturer	Part Number	Product Name	Description
Taoglas	PA.710.A	Warrior	GSM / WCDMA / LTE SMD Antenna 698..960 MHz, 1710..2170 MHz, 2300..2400 MHz, 2490..2690 MHz 40.0 x 6.0 x 5.0 mm
Taoglas	PA.711.A	Warrior II	GSM / WCDMA / LTE SMD Antenna Pairs with the Taoglas PA.710.A Warrior for LTE MIMO applications 698..960 MHz, 1710..2170 MHz, 2300..2400 MHz, 2490..2690 MHz 40.0 x 6.0 x 5.0 mm
Taoglas	PCS.06.A	Havok	GSM / WCDMA / LTE SMD Antenna 698..960 MHz, 1710..2170 MHz, 2500..2690 MHz 42.0 x 10.0 x 3.0 mm

Table 25: Examples of internal surface-mount antennas

Table 26 lists some examples of possible internal off-board PCB-type antennas with cable and connector.

Manufacturer	Part Number	Product Name	Description
Taoglas	FXUB63.07.0150C		GSM / WCDMA / LTE PCB Antenna with cable and U.FL 698..960 MHz, 1575.42 MHz, 1710..2170 MHz, 2400..2690 MHz 96.0 x 21.0 mm
Taoglas	FXUB66.07.0150C	Maximus	GSM / WCDMA / LTE PCB Antenna with cable and U.FL 698..960 MHz, 1390..1435 MHz, 1575.42 MHz, 1710..2170 MHz, 2400..2700 MHz, 3400..3600 MHz, 4800..6000 MHz 120.2 x 50.4 mm
Taoglas	FXUB70.A.07.C.001		GSM / WCDMA / LTE PCB MIMO Antenna with cables and U.FL 698..960 MHz, 1575.42 MHz, 1710..2170 MHz, 2400..2690 MHz 182.2 x 21.2 mm
Ethertronics	5001537	Prestta	GSM / WCDMA / LTE PCB Antenna with cable 704..960 MHz, 1710..2170 MHz, 2300..2400 MHz, 2500..2690 MHz 80.0 x 18.0 mm
EAD	FSQS35241-UF-10	SQ7	GSM / WCDMA / LTE PCB Antenna with cable and U.FL 690..960 MHz, 1710..2170 MHz, 2500..2700 MHz 110.0 x 21.0 mm

Table 26: Examples of internal antennas with cable and connector

Table 27 lists some examples of possible external antennas.

Manufacturer	Part Number	Product Name	Description
Taoglas	GSA.8827.A.101111	Phoenix	GSM / WCDMA / LTE adhesive-mount antenna with cable and SMA(M) 698..960 MHz, 1575.42 MHz, 1710..2170 MHz, 2490..2690 MHz 105 x 30 x 7.7 mm
Taoglas	TG.30.8112		GSM / WCDMA / LTE swivel dipole antenna with SMA(M) 698..960 MHz, 1575.42 MHz, 1710..2170 MHz, 2400..2700 MHz 148.6 x 49 x 10 mm
Taoglas	MA241.BI.001	Genesis	GSM / WCDMA / LTE MIMO 2in1 adhesive-mount combination antenna waterproof IP67 rated with cable and SMA(M) 698..960 MHz, 1710..2170 MHz, 2400..2700 MHz 205.8 x 58 x 12.4 mm
Laird Tech.	TRA6927M3PW-001		GSM / WCDMA / LTE screw-mount antenna with N-type(F) 698..960 MHz, 1710..2170 MHz, 2300..2700 MHz 83.8 x Ø 36.5 mm
Laird Tech.	CMS69273		GSM / WCDMA / LTE ceiling-mount antenna with cable and N-type(F) 698..960 MHz, 1575.42 MHz, 1710..2700 MHz 86 x Ø 199 mm
Laird Tech.	OC69271-FNM		GSM / WCDMA / LTE pole-mount antenna with N-type(M) 698..960 MHz, 1710..2690 MHz 248 x Ø 24.5 mm
Laird Tech.	CMD69273-30NM		GSM / WCDMA / LTE ceiling-mount MIMO antenna with cables & N-type(M) 698..960 MHz, 1710..2700 MHz 43.5 x Ø 218.7 mm
Pulse Electronics	WA700/2700SMA		GSM / WCDMA / LTE clip-mount MIMO antenna with cables and SMA(M) 698..960 MHz, 1710..2700 MHz 149 x 127 x 5.1 mm

Table 27: Examples of external antennas

2.4.2 Antenna detection interface (ANT_DET)



Antenna detection (**ANT_DET**) is not available on MPC1-L2 series modules



Antenna detection (**ANT_DET**) is not supported by TOBY-L2 "00", "01", and "50" product versions

2.4.2.1 Guidelines for ANT_DET circuit design

Figure 48 and Table 28 describe the recommended schematic / components for the antennas detection circuit that must be provided on the application board and for the diagnostic circuit that must be provided on the antennas' assembly to achieve primary and secondary antenna detection functionality.

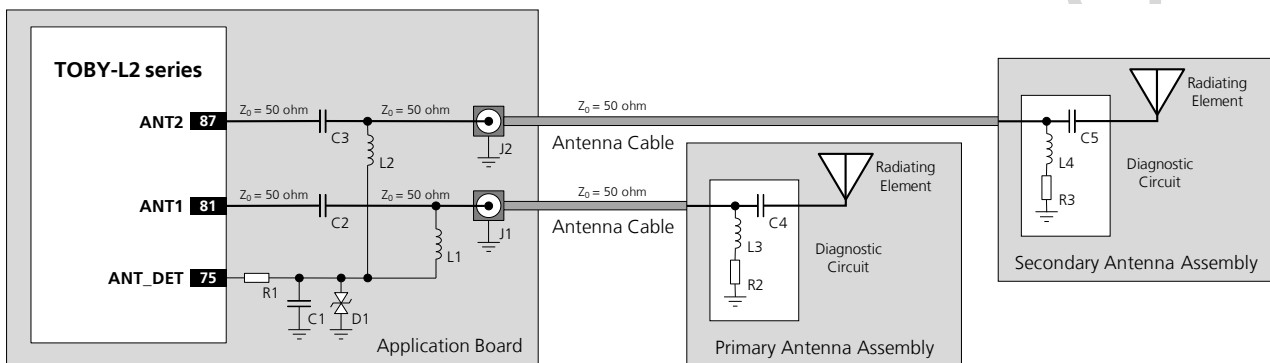

Figure 48: Suggested schematic for antenna detection circuit on application board and diagnostic circuit on antennas assembly

Reference	Description	Part Number - Manufacturer
C1	27 pF Capacitor Ceramic COG 0402 5% 50 V	GRM1555C1H270J - Murata
C2, C3	33 pF Capacitor Ceramic COG 0402 5% 50 V	GRM1555C1H330J - Murata
D1	Very Low Capacitance ESD Protection	PESD0402-140 - Tyco Electronics
L1, L2	68 nH Multilayer Inductor 0402 (SRF ~1 GHz)	LQG15HS68NJ02 - Murata
R1	10 kΩ Resistor 0402 1% 0.063 W	RK73H1ETTP1002F - KOA Speer
J1, J2	SMA Connector 50 Ω Through Hole Jack	SMA6251A1-3GT50G-50 - Amphenol
C4, C5	22 pF Capacitor Ceramic COG 0402 5% 25 V	GRM1555C1H220J - Murata
L3, L4	68 nH Multilayer Inductor 0402 (SRF ~1 GHz)	LQG15HS68NJ02 - Murata
R2, R3	15 kΩ Resistor for Diagnostic	Various Manufacturers

Table 28: Suggested components for antenna detection circuit on application board and diagnostic circuit on antennas assembly

The antenna detection circuit and diagnostic circuit suggested in Figure 48 and Table 28 are explained here:

- When antenna detection is forced by AT+UANTR command, **ANT_DET** generates a DC current measuring the resistance ($R2 // R3$) from antenna connectors (J1, J2) provided on the application board to GND.
- DC blocking capacitors are needed at the **ANT1 / ANT2** pins (C2, C3) and at the antenna radiating element (C4, C5) to decouple the DC current generated by the **ANT_DET** pin.
- Choke inductors with a Self Resonance Frequency (SRF) in the range of 1 GHz are needed in series at the **ANT_DET** pin (L1, L2) and in series at the diagnostic resistor (L3, L4), to avoid a reduction of the RF performance of the system, improving the RF isolation of the load resistor.
- Additional components (R1, C1 and D1 in Figure 48) are needed at the **ANT_DET** pin as ESD protection
- The **ANT1 / ANT2** pins must be connected to the antenna connector by means of a transmission line with nominal characteristics impedance as close as possible to 50 Ω.

The DC impedance at RF port for some antennas may be a DC open (e.g. linear monopole) or a DC short to reference GND (e.g. PIFA antenna). For those antennas, without the diagnostic circuit of Figure 48, the measured DC resistance is always at the limits of the measurement range (respectively open or short), and there is no means to distinguish between a defect on antenna path with similar characteristics (respectively: removal of linear antenna or RF cable shorted to GND for PIFA antenna).

Furthermore, any other DC signal injected to the RF connection from ANT connector to radiating element will alter the measurement and produce invalid results for antenna detection.



It is recommended to use an antenna with a built-in diagnostic resistor in the range from 5 k Ω to 30 k Ω to assure good antenna detection functionality and avoid a reduction of module RF performance. The choke inductor should exhibit a parallel Self Resonance Frequency (SRF) in the range of 1 GHz to improve the RF isolation of load resistor.

For example:

Consider an antenna with built-in DC load resistor of 15 k Ω . Using the +UANTR AT command, the module reports the resistance value evaluated from the antenna connector provided on the application board to GND:

- Reported values close to the used diagnostic resistor nominal value (i.e. values from 13 k Ω to 17 k Ω if a 15 k Ω diagnostic resistor is used) indicate that the antenna is properly connected.
- Values close to the measurement range maximum limit (approximately 50 k Ω) or an open-circuit "over range" report (see u-blox AT Commands Manual [3]) means that the antenna is not connected or the RF cable is broken.
- Reported values below the measurement range minimum limit (1 k Ω) highlights a short to GND at antenna or along the RF cable.
- Measurement inside the valid measurement range and outside the expected range may indicate an improper connection, damaged antenna or wrong value of antenna load resistor for diagnostic.
- Reported value could differ from the real resistance value of the diagnostic resistor mounted inside the antenna assembly due to antenna cable length, antenna cable capacity and the used measurement method.



If the primary / secondary antenna detection function is not required by the customer application, the **ANT_DET** pin can be left not connected and the **ANT1 / ANT2** pins can be directly connected to the related antenna connector by means of a 50 Ω transmission line as described in Figure 47.

2.4.2.1 Guidelines for ANT_DET layout design

The recommended layout for the primary antenna detection circuit to be provided on the application board to achieve the primary antenna detection functionality, implementing the recommended schematic described in Figure 48 and Table 28, is explained here:

- The **ANT1 / ANT2** pins have to be connected to the antenna connector by means of a 50 Ω transmission line, implementing the design guidelines described in section 2.4.1 and the recommendations of the SMA connector manufacturer.
- DC blocking capacitor at **ANT1 / ANT2** pins (C2, C3) has to be placed in series to the 50 Ω RF line.
- The **ANT_DET** pin has to be connected to the 50 Ω transmission line by means of a sense line.
- Choke inductors in series at the **ANT_DET** pin (L1, L2) have to be placed so that one pad is on the 50 Ω transmission line and the other pad represents the start of the sense line to the **ANT_DET** pin.
- The additional components (R1, C1 and D1) on the **ANT_DET** line have to be placed as ESD protection.

2.5 SIM interface



SIM detection interface (**GPIO5**) is not available on the MPC1-L2 series modules.



SIM detection interface (**GPIO5**) is not supported by the TOBY-L2 "00", "01", and "50" product versions: the pin should not be driven by any external device.

2.5.1 Guidelines for SIM circuit design

Guidelines for SIM cards, SIM connectors and SIM chips selection

The ISO/IEC 7816, the ETSI TS 102 221 and the ETSI TS 102 671 specifications define the physical, electrical and functional characteristics of Universal Integrated Circuit Cards (UICC), which contains the Subscriber Identification Module (SIM) integrated circuit that securely stores all the information needed to identify and authenticate subscribers over the LTE/3G/2G network.

Removable UICC / SIM card contacts mapping is defined by ISO/IEC 7816 and ETSI TS 102 221 as follows:

- Contact C1 = VCC (Supply) → It must be connected to **VSIM** or **UIM_PWR**
- Contact C2 = RST (Reset) → It must be connected to **SIM_RST** or **UIM_RESET**
- Contact C3 = CLK (Clock) → It must be connected to **SIM_CLK** or **UIM_CLK**
- Contact C4 = AUX1 (Auxiliary contact) → It must be left not connected
- Contact C5 = GND (Ground) → It must be connected to **GND**
- Contact C6 = VPP (Programming supply) → It must be connected to **VSIM** or **UIM_PWR**
- Contact C7 = I/O (Data input/output) → It must be connected to **SIM_IO** or **UIM_DATA**
- Contact C8 = AUX2 (Auxiliary contact) → It must be left not connected

A removable SIM card can have 6 contacts (C1, C2, C3, C5, C6, C7) or 8 contacts, also including the auxiliary contacts C4 and C8. Only 6 contacts are required and must be connected to the module SIM interface.

Removable SIM cards are suitable for applications requiring a change of SIM card during the product lifetime.

A SIM card holder can have 6 or 8 positions if a mechanical card presence detector is not provided, or it can have 6+2 or 8+2 positions if two additional pins relative to the normally-open mechanical switch integrated in the SIM connector for the mechanical card presence detection are provided. Select a SIM connector providing 6+2 or 8+2 positions if the optional SIM detection feature (not available on MPC1-L2 series) is required by the custom application, otherwise a connector without integrated mechanical presence switch can be selected.

Solderable UICC / SIM chip contact mapping (M2M UICC Form Factor) is defined by ETSI TS 102 671 as:

- Case Pin 8 = UICC Contact C1 = VCC (Supply) → It must be connected to **VSIM** or **UIM_PWR**
- Case Pin 7 = UICC Contact C2 = RST (Reset) → It must be connected to **SIM_RST** or **UIM_RESET**
- Case Pin 6 = UICC Contact C3 = CLK (Clock) → It must be connected to **SIM_CLK** or **UIM_CLK**
- Case Pin 5 = UICC Contact C4 = AUX1 (Aux.contact) → It must be left not connected
- Case Pin 1 = UICC Contact C5 = GND (Ground) → It must be connected to **GND**
- Case Pin 2 = UICC Contact C6 = VPP (Progr. supply) → It must be connected to **VSIM** or **UIM_PWR**
- Case Pin 3 = UICC Contact C7 = I/O (Data I/O) → It must be connected to **SIM_IO** or **UIM_DATA**
- Case Pin 4 = UICC Contact C8 = AUX2 (Aux. contact) → It must be left not connected

A solderable SIM chip has 8 contacts and can also include the auxiliary contacts C4 and C8 for other uses, but only 6 contacts are required and must be connected to the module SIM card interface as described above.

Solderable SIM chips are suitable for M2M applications where it is not required to change the SIM once installed.

Guidelines for single SIM card connection without detection

A removable SIM card placed in a SIM card holder must be connected to the SIM card interface of TOBY-L2 and MPC1-L2 series modules as described in Figure 49, where the optional SIM detection feature is not implemented.

Follow these guidelines to connect the module to a SIM connector without SIM presence detection:

- Connect the UICC / SIM contacts C1 (VCC) and C6 (VPP) to the **VSIM / UIM_PWR** pin of the module.
- Connect the UICC / SIM contact C7 (I/O) to the **SIM_IO / UIM_DATA** pin of the module.
- Connect the UICC / SIM contact C3 (CLK) to the **SIM_CLK / UIM_CLK** pin of the module.
- Connect the UICC / SIM contact C2 (RST) to the **SIM_RST / UIM_RESET** pin of the module.
- Connect the UICC / SIM contact C5 (GND) to ground.
- Provide a 100 nF bypass capacitor (e.g. Murata GRM155R71C104K) on SIM supply line, close to the relative pad of the SIM connector, to prevent digital noise.
- Provide a bypass capacitor of about 22 pF to 47 pF (e.g. Murata GRM1555C1H470J) on each SIM line, very close to each related pad of the SIM connector, to prevent RF coupling especially in case the RF antenna is placed closer than 10 - 30 cm from the SIM card holder.
- Provide a very low capacitance (i.e. less than 10 pF) ESD protection (e.g. Tyco PESD0402-140) on each externally accessible SIM line, close to each relative pad of the SIM connector. ESD sensitivity rating of the SIM interface pins is 1 kV (HBM). So that, according to EMC/ESD requirements of the custom application, higher protection level can be required if the lines are externally accessible on the application device.
- Limit capacitance and series resistance on each SIM signal to match the SIM requirements (27.7 ns is the maximum allowed rise time on clock line, 1.0 μ s is the maximum allowed rise time on data and reset lines).

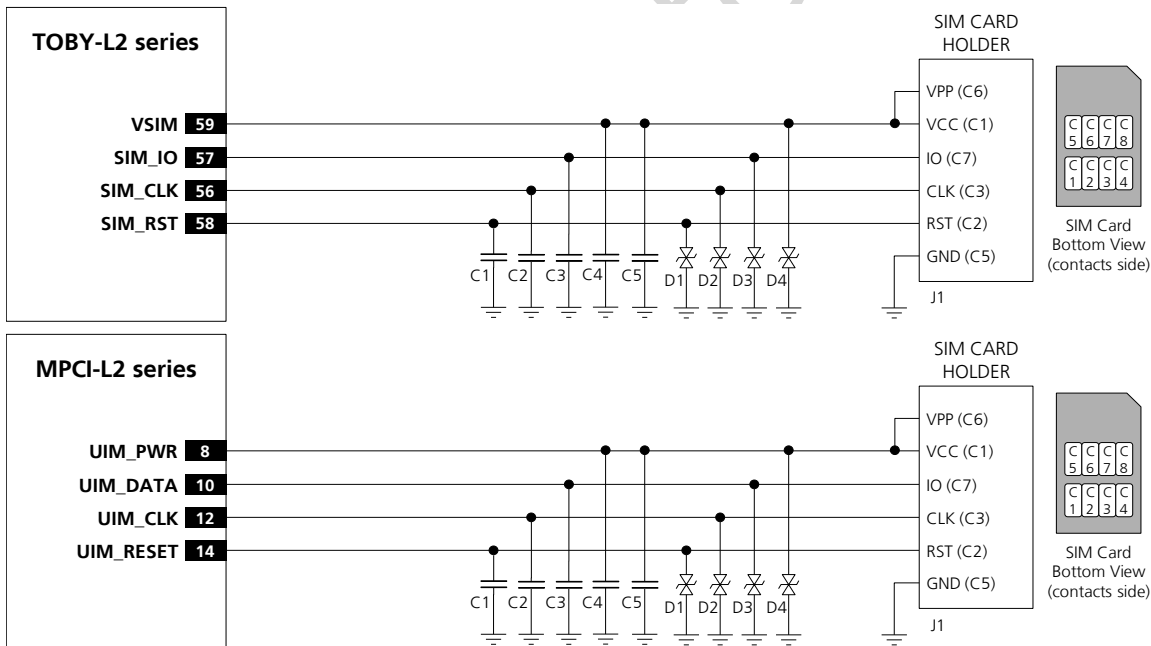

Figure 49: Application circuits for the connection to a single removable SIM card, with SIM detection not implemented

Reference	Description	Part Number - Manufacturer
C1, C2, C3, C4	47 pF Capacitor Ceramic COG 0402 5% 50 V	GRM1555C1H470JA01 - Murata
C5	100 nF Capacitor Ceramic X7R 0402 10% 16 V	GRM155R71C104KA01 - Murata
D1, D2, D3, D4	Very Low Capacitance ESD Protection	PESD0402-140 - Tyco Electronics
J1	SIM Card Holder, 6 p, without card presence switch	Various manufacturers, as C707 10M006 136 2 - Amphenol

Table 29: Example of components for the connection to a single removable SIM card, with SIM detection not implemented

Guidelines for single SIM chip connection

A solderable SIM chip (M2M UICC Form Factor) must be connected the SIM card interface of TOBY-L2 and MPC1-L2 series modules as described in Figure 50.

Follow these guidelines to connect the module to a solderable SIM chip without SIM presence detection:

- Connect the UICC / SIM contacts C1 (VCC) and C6 (VPP) to the **VSIM / UIM_PWR** pin of the module.
- Connect the UICC / SIM contact C7 (I/O) to the **SIM_IO / UIM_DATA** pin of the module.
- Connect the UICC / SIM contact C3 (CLK) to the **SIM_CLK / UIM_CLK** pin of the module.
- Connect the UICC / SIM contact C2 (RST) to the **SIM_RST / UIM_RESET** pin of the module.
- Connect the UICC / SIM contact C5 (GND) to ground.
- Provide a 100 nF bypass capacitor (e.g. Murata GRM155R71C104K) at the SIM supply line close to the relative pad of the SIM chip, to prevent digital noise.
- Provide a bypass capacitor of about 22 pF to 47 pF (e.g. Murata GRM155C1H470J) on each SIM line, to prevent RF coupling especially in case the RF antenna is placed closer than 10 - 30 cm from the SIM lines.
- Limit capacitance and series resistance on each SIM signal to match the SIM requirements (27.7 ns is the maximum allowed rise time on clock line, 1.0 μ s is the maximum allowed rise time on data and reset lines).

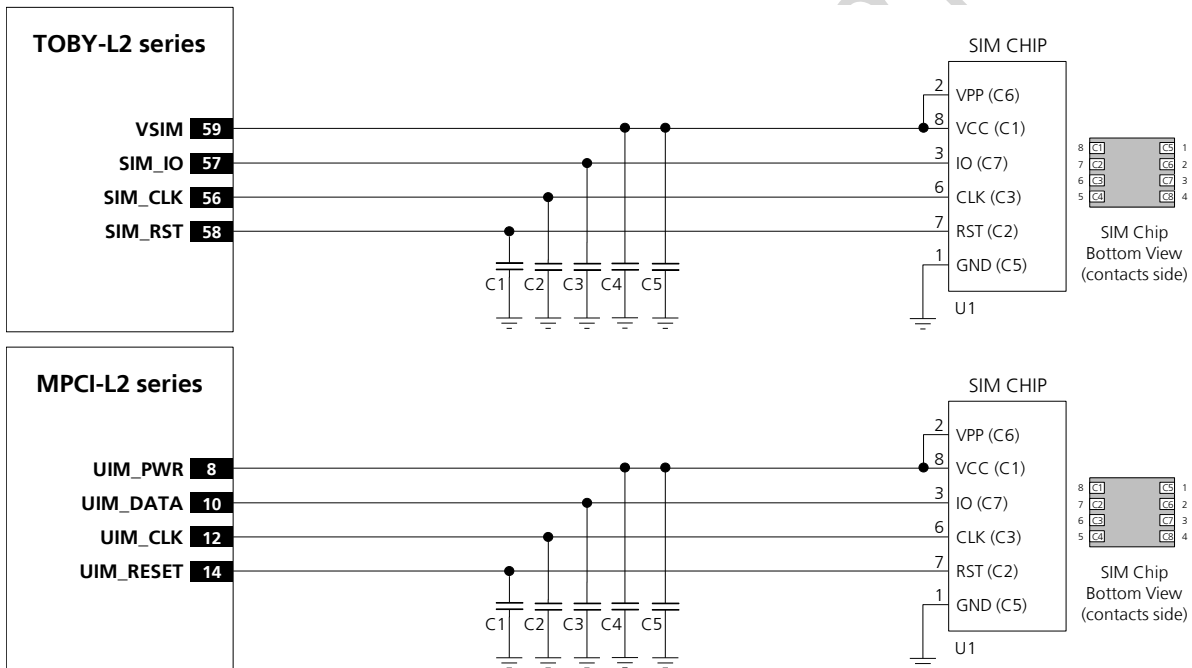

Figure 50: Application circuits for the connection to a single solderable SIM chip, with SIM detection not implemented

Reference	Description	Part Number - Manufacturer
C1, C2, C3, C4	47 pF Capacitor Ceramic C0G 0402 5% 50 V	GRM155C1H470JA01 - Murata
C5	100 nF Capacitor Ceramic X7R 0402 10% 16 V	GRM155R71C104KA01 - Murata
U1	SIM chip (M2M UICC Form Factor)	Various Manufacturers

Table 30: Example of components for the connection to a single solderable SIM chip, with SIM detection not implemented

Guidelines for single SIM card connection with detection

A removable SIM card placed in a SIM card holder must be connected to the SIM card interface of TOBY-L2 modules as described in Figure 51, where the optional SIM card detection feature is implemented.

Follow these guidelines to connect the module to a SIM connector implementing SIM presence detection:

- Connect the UICC / SIM contacts C1 (VCC) and C6 (VPP) to the **VSIM** pin of the module.
- Connect the UICC / SIM contact C7 (I/O) to the **SIM_IO** pin of the module.
- Connect the UICC / SIM contact C3 (CLK) to the **SIM_CLK** pin of the module.
- Connect the UICC / SIM contact C2 (RST) to the **SIM_RST** pin of the module.
- Connect the UICC / SIM contact C5 (GND) to ground.
- Connect one pin of the mechanical switch integrated in the SIM connector (e.g. the SW2 pin as described in Figure 51) to the **GPIO5** input pin of the module.
- Connect the other pin of the mechanical switch integrated in the SIM connector (e.g. the SW1 pin as described in Figure 51) to the **V_INT** 1.8 V supply output of the module by means of a strong (e.g. 1 k Ω) pull-up resistor, as the R1 resistor in Figure 51.
- Provide a weak (e.g. 470 k Ω) pull-down resistor at the SIM detection line, as the R2 resistor in Figure 51
- Provide a 100 nF bypass capacitor (e.g. Murata GRM155R71C104K) at the SIM supply line, close to the related pad of the SIM connector, to prevent digital noise.
- Provide a bypass capacitor of about 22 pF to 47 pF (e.g. Murata GRM1555C1H470J) on each SIM line, very close to each related pad of the SIM connector, to prevent RF coupling especially in case the RF antenna is placed closer than 10 - 30 cm from the SIM card holder.
- Provide a very low capacitance (i.e. less than 10 pF) ESD protection (e.g. Tyco PESD0402-140) on each externally accessible SIM line, close to each related pad of the SIM connector: ESD sensitivity rating of the SIM interface pins is 1 kV (HBM), so that, according to the EMC/ESD requirements of the custom application, higher protection level can be required if the lines are externally accessible on the application device.
- Limit capacitance and series resistance on each SIM signal to match the SIM requirements (27.7 ns is the maximum allowed rise time on clock line, 1.0 μ s is the maximum allowed rise time on data and reset lines).

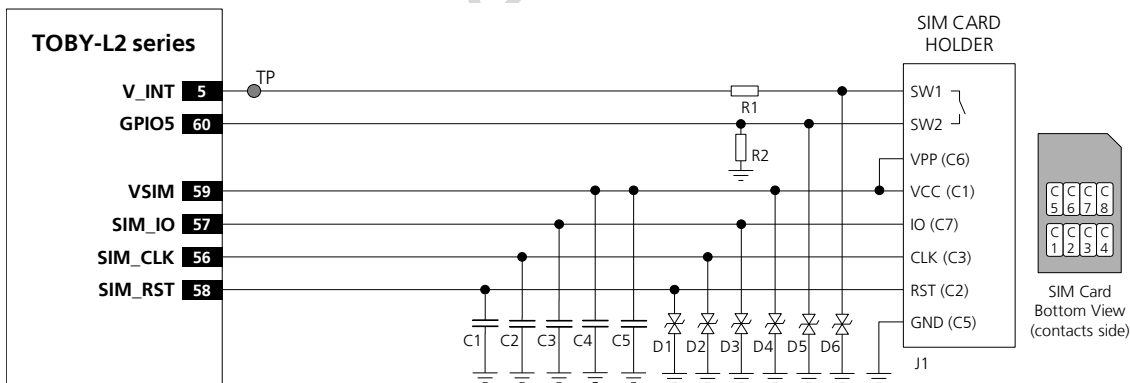

Figure 51: Application circuit for the connection to a single removable SIM card, with SIM detection implemented

Reference	Description	Part Number - Manufacturer
C1, C2, C3, C4	47 pF Capacitor Ceramic C0G 0402 5% 50 V	GRM1555C1H470JA01 - Murata
C5	100 nF Capacitor Ceramic X7R 0402 10% 16 V	GRM155R71C104KA01 - Murata
D1, ... , D6	Very Low Capacitance ESD Protection	PESD0402-140 - Tyco Electronics
R1	1 k Ω Resistor 0402 5% 0.1 W	RC0402JR-071KL - Yageo Phycomp
R2	470 k Ω Resistor 0402 5% 0.1 W	RC0402JR-07470KL- Yageo Phycomp
J1	SIM Card Holder, 6 + 2 p, with card presence switch	Various manufacturers, as CCM03-3013LFT R102 - C&K

Table 31: Example of components for the connection to a single removable SIM card, with SIM detection implemented

Guidelines for dual SIM card / chip connection

Two SIM card / chip can be connected to the SIM interface of TOBY-L2 and MPC1-L2 series modules as described in the application circuits of Figure 52.

TOBY-L2 and MPC1-L2 series modules do not support the usage of two SIM at the same time, but two SIM can be populated on the application board, providing a proper switch to connect only the first or only the second SIM at a time to the SIM interface of the modules, as described in Figure 52.

TOBY-L2 "00", "01", and "50" product versions and MPC1-L2 modules do not support SIM hot insertion / removal functionality: the physical connection between the external SIM and the module has to be provided before the module boot and then held for normal operation. Switching from one SIM to another can only be properly done within one of these two time periods:

- after module switch-off by the AT+CPWROFF and before module switch-on by **PWR_ON**
- after network deregistration by AT+COPS=2 and before module reset by AT+CFUN=16

TOBY-L2 modules (except "00", "01", "50" product versions) support SIM hot insertion / removal on the **GPIO5** pin: if the feature is enabled using the specific AT commands (see sections 1.8.2 and 1.11, and u-blox AT Commands Manual [3], +UGPIOC, +UDCONF commands), the switch from first SIM to the second SIM can be properly done when a Low logic level is present on the **GPIO5** pin ("SIM not inserted" = SIM interface not enabled), without the necessity of a module re-boot, so that the SIM interface will be re-enabled by the module to use the second SIM when a high logic level is re-applied on the **GPIO5** pin.

In the application circuit example represented in Figure 52, the application processor will drive the SIM switch using its own GPIO to properly select the SIM that is used by the module. Another GPIO may be used to handle the SIM hot insertion / removal function of TOBY-L2 modules, which can also be handled by other external circuits or by the cellular module GPIO according to the application requirements.

The dual SIM connection circuit described in Figure 52 can be implemented for SIM chips as well, providing proper connection between SIM switch and SIM chip as described in Figure 50.

If it is required to switch between more than 2 SIM, a circuit similar to the one described in Figure 52 can be implemented: in case of 4 SIM circuit, using proper 4-throw switch instead of the suggested 2-throw switches.

Follow these guidelines to connect the module to two external SIM connectors:

- Use a proper low on resistance (i.e. few ohms) and low on capacitance (i.e. few pF) 2-throw analog switch (e.g. Fairchild FSA2567) as SIM switch to ensure high-speed data transfer according to SIM requirements.
- Connect the contacts C1 (VCC) and C6 (VPP) of the two UICC / SIM to the **VSIM / UIM_PWR** pin of the module by means of a proper 2-throw analog switch (e.g. Fairchild FSA2567).
- Connect the contact C7 (I/O) of the two UICC / SIM to the **SIM_IO / UIM_DATA** pin of the module by means of a proper 2-throw analog switch (e.g. Fairchild FSA2567).
- Connect the contact C3 (CLK) of the two UICC / SIM to the **SIM_CLK / UIM_CLK** pin of the module by means of a proper 2-throw analog switch (e.g. Fairchild FSA2567).
- Connect the contact C2 (RST) of the two UICC / SIM to the **SIM_RST / UIM_RESET** pin of the module by means of a proper 2-throw analog switch (e.g. Fairchild FSA2567).
- Connect the contact C5 (GND) of the two UICC / SIM to ground.
- Provide a 100 nF bypass capacitor (e.g. Murata GRM155R71C104K) at the SIM supply (**VSIM / UIM_PWR**), close to the related pad of the two SIM connectors, to prevent digital noise.
- Provide a bypass capacitor of about 22 pF to 47 pF (e.g. Murata GRM1555C1H470J) on each SIM line, very close to each related pad of the two SIM connectors, to prevent RF coupling especially in case the RF antenna is placed closer than 10 - 30 cm from the SIM card holders.
- Provide a very low capacitance (i.e. less than 10 pF) ESD protection (e.g. Tyco Electronics PESD0402-140) on each externally accessible SIM line, close to each pad of the two SIM connectors, according to the EMC/ESD requirements of the custom application.
- Limit capacitance and series resistance on each SIM signal to match the SIM requirements (27.7 ns is the maximum allowed rise time on clock line, 1.0 μs is the maximum allowed rise time on data and reset lines).

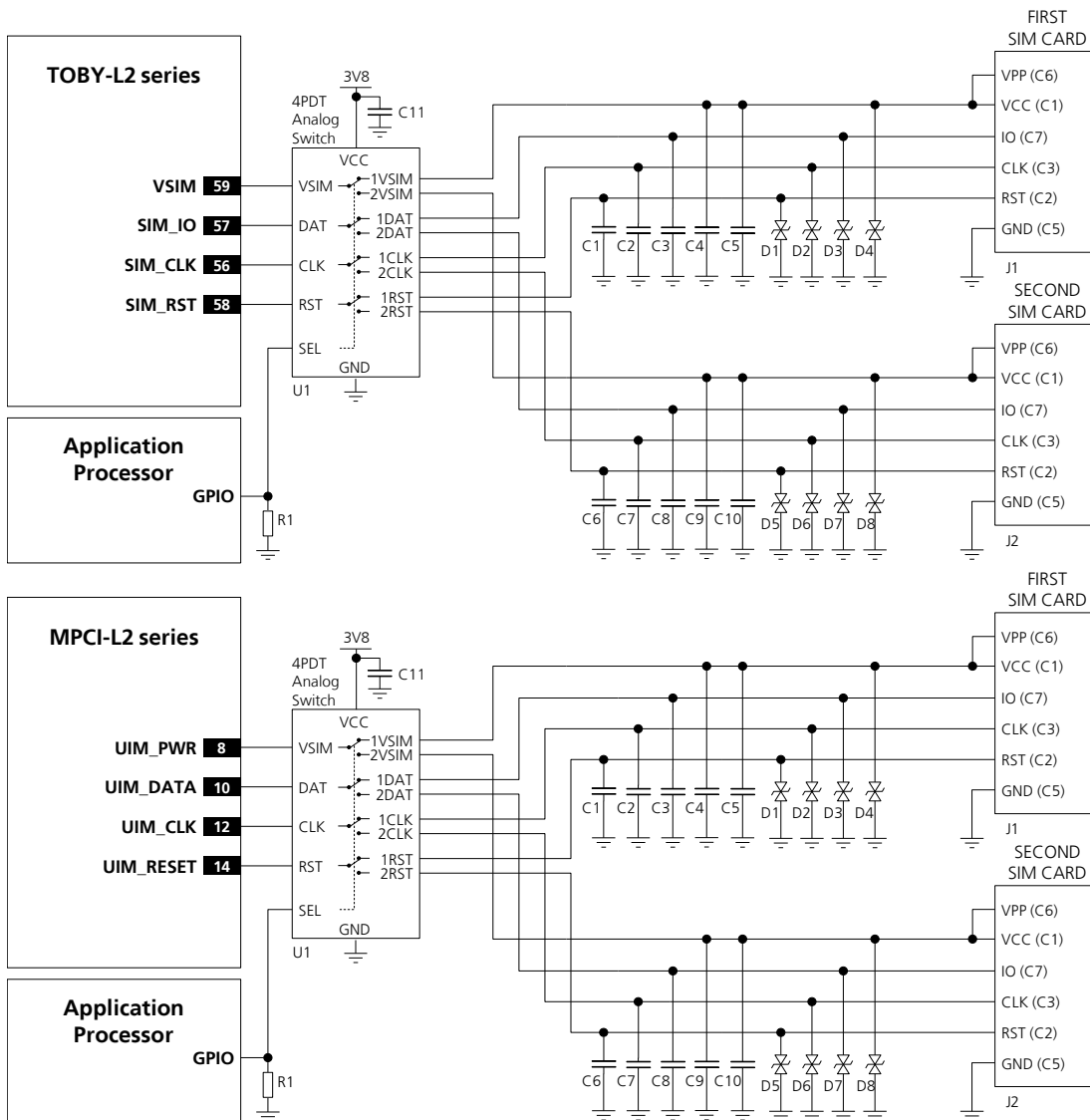

Figure 52: Application circuit for the connection to two removable SIM cards, with SIM detection not implemented

Reference	Description	Part Number – Manufacturer
C1 – C4, C6 – C9	33 pF Capacitor Ceramic C0G 0402 5% 25 V	GRM1555C1H330JZ01 – Murata
C5, C10, C11	100 nF Capacitor Ceramic X7R 0402 10% 16 V	GRM155R71C104KA01 – Murata
D1 – D8	Very Low Capacitance ESD Protection	PESD0402-140 - Tyco Electronics
R1	47 kΩ Resistor 0402 5% 0.1 W	RC0402JR-0747KL- Yageo Phycomp
J1, J2	SIM Card Holder, 6 + 2 p., with card presence switch	CCM03-3013LFT R102 - C&K Components
U1	4PDT Analog Switch, with Low On-Capacitance and Low On-Resistance	FSA2567 - Fairchild Semiconductor

Table 32: Example of components for the connection to two removable SIM cards, with SIM detection not implemented

2.5.2 Guidelines for SIM layout design

The layout of the SIM card interface lines (**VSIM**, **SIM_CLK**, **SIM_IO**, **SIM_RST** or **UIM_PWR**, **UIM_DATA**, **UIM_CLK**, **UIM_RESET**) may be critical if the SIM card is placed far away from the TOBY-L2 and MPC1-L2 series modules or in close proximity to the RF antenna: these two cases should be avoided or at least mitigated as described below.

In the first case, the long connection can cause the radiation of some harmonics of the digital data frequency as any other digital interface. It is recommended to keep the traces short and avoid coupling with RF line or sensitive analog inputs.

In the second case, the same harmonics can be picked up and create self-interference that can reduce the sensitivity of LTE/3G/2G receiver channels whose carrier frequency is coincidental with harmonic frequencies. It is strongly recommended to place the RF bypass capacitors suggested in Figure 49 near the SIM connector.

In addition, since the SIM card is typically accessed by the end user, it can be subjected to ESD discharges. Add adequate ESD protection as suggested to protect module SIM pins near the SIM connector.

Limit capacitance and series resistance on each SIM signal to match the SIM specifications. The connections should always be kept as short as possible.

Avoid coupling with any sensitive analog circuit, since the SIM signals can cause the radiation of some harmonics of the digital data frequency.

Advance Information

2.6 Data communication interfaces

2.6.1 Universal Serial Bus (USB)

2.6.1.1 Guidelines for USB circuit design

The **USB_D+** and **USB_D-** lines carry the USB serial data and signaling. The lines are used in single ended mode for full speed signaling handshake, as well as in differential mode for high speed signaling and data transfer.

USB pull-up or pull-down resistors and external series resistors on **USB_D+** and **USB_D-** lines as required by the USB 2.0 specification [6] are part of the module USB pin driver and do not need to be externally provided.

The additional **VUSB_DET** input is available as optional feature to sense the host VBUS voltage (5.0 V typical).

The **VUSB_DET** functionality is not supported by TOBY-L2 "00", "01", and "50" product versions: the pin should be left unconnected or it should not be driven high (for more details, see section 1.9.1.1).

The **VUSB_DET** pin is not available on MPC1-L2 series modules.

Routing the USB pins to a connector, they will be externally accessible on the application device. According to EMC/ESD requirements of the application, an additional ESD protection device with very low capacitance should be provided close to accessible point on the line connected to this pin, as described in Figure 53 and Table 33.

The USB interface pins ESD sensitivity rating is 1 kV (Human Body Model according to JESD22-A114F). Higher protection level could be required if the lines are externally accessible and it can be achieved by mounting a very low capacitance (i.e. less or equal to 1 pF) ESD protection (e.g. Tyco Electronics PESD0402-140 ESD protection device) on the lines connected to these pins, close to accessible points.

The **USB_D+** and **USB_D-** pins of the modules can be directly connected to the USB host application processor without additional ESD protections if they are not externally accessible or according to EMC/ESD requirements.

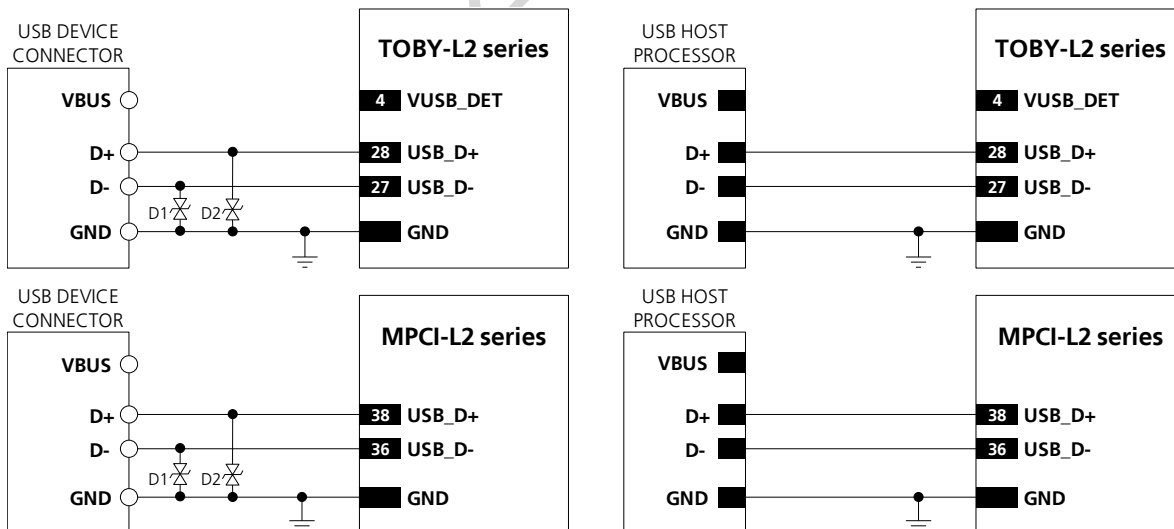

Figure 53: USB Interface application circuits

Reference	Description	Part Number - Manufacturer
D1, D2	Very Low Capacitance ESD Protection	PESD0402-140 - Tyco Electronics

Table 33: Component for USB application circuits



If the USB interface pins are not used, they can be left unconnected on the application board, but it is recommended providing accessible test points directly connected to **USB_D+** and **USB_D-** pins.

2.6.1.2 Guidelines for USB layout design

The **USB_D+** / **USB_D-** lines require accurate layout design to achieve reliable signaling at the high speed data rate (up to 480 Mb/s) supported by the USB serial interface.

The characteristic impedance of the **USB_D+** / **USB_D-** lines is specified by the Universal Serial Bus Revision 2.0 specification [6]. The most important parameter is the differential characteristic impedance applicable for the odd-mode electromagnetic field, which should be as close as possible to $90\ \Omega$ differential. Signal integrity may be degraded if PCB layout is not optimal, especially when the USB signaling lines are very long.

Use the following general routing guidelines to minimize signal quality problems:

- Route **USB_D+** / **USB_D-** lines as a differential pair
- Route **USB_D+** / **USB_D-** lines as short as possible
- Ensure the differential characteristic impedance (Z_o) is as close as possible to $90\ \Omega$
- Ensure the common mode characteristic impedance (Z_{cm}) is as close as possible to $30\ \Omega$
- Consider design rules for **USB_D+** / **USB_D-** similar to RF transmission lines, being them coupled differential micro-strip or buried stripline: avoid any stubs, abrupt change of layout, and route on clear PCB area

Figure 54 and Figure 55 provide two examples of coplanar waveguide designs with differential characteristic impedance close to $90\ \Omega$ and common mode characteristic impedance close to $30\ \Omega$. The first transmission line can be implemented in case of 4-layer PCB stack-up herein described, the second transmission line can be implemented in case of 2-layer PCB stack-up herein described.

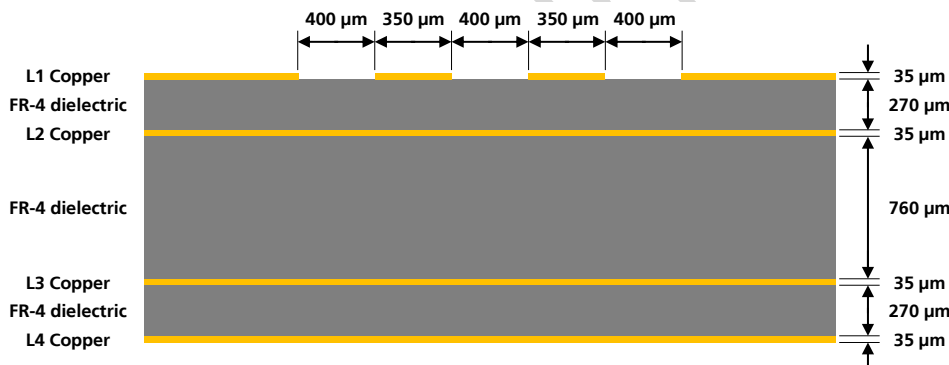

Figure 54: Example of USB line design, with Z_o close to $90\ \Omega$ and Z_{cm} close to $30\ \Omega$, for the described 4-layer board layout

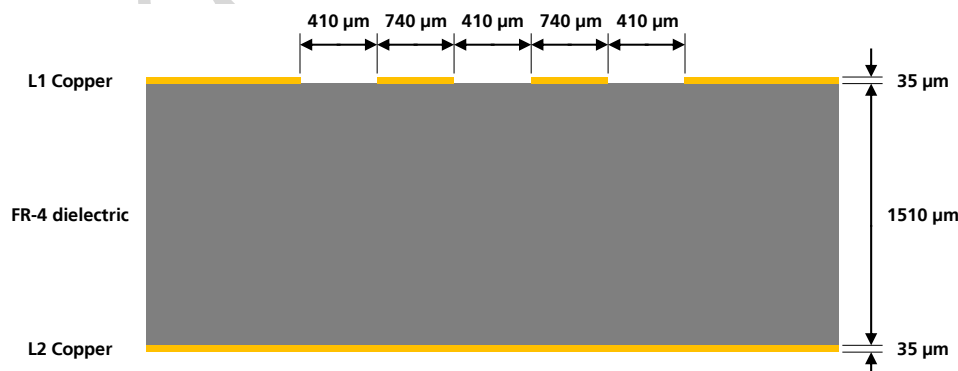

Figure 55: Example of USB line design, with Z_o close to $90\ \Omega$ and Z_{cm} close to $30\ \Omega$, for the described 2-layer board layout

2.6.2 Asynchronous serial interface (UART)

The UART interface is not available on MPC1-L2 series modules.

2.6.2.1 Guidelines for UART circuit design

The UART interface is not supported by TOBY-L200-00S and TOBY-L210-00S product versions: all the UART pins should not be driven by any external device.

The **DTR**, **DSR** and **DCD** signals are not supported by TOBY-L200-50S, TOBY-L210-50S product versions: the pins should not be driven by any external device.

Providing the full RS-232 functionality (using the complete V.24 link)

If RS-232 compatible signal levels are needed, two different external voltage translators can be used to provide full RS-232 (9 lines) functionality: e.g. using the Texas Instruments SN74AVC8T245PW for the translation from 1.8 V to 3.3 V, and the Maxim MAX3237E for the translation from 3.3 V to RS-232 compatible signal level.

If a 1.8 V Application Processor (DTE) is used and complete RS-232 functionality is required, then the complete 1.8 V UART interface of the module (DCE) should be connected to a 1.8 V DTE, as described in Figure 56.

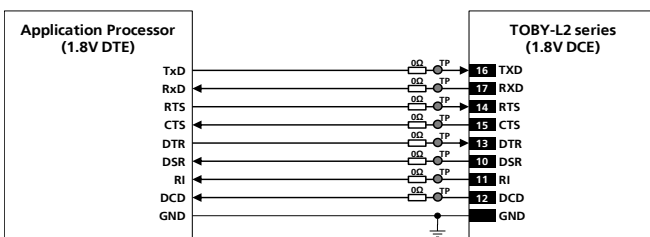

Figure 56: UART interface application circuit with complete V.24 link in DTE/DCE serial communication (1.8V DTE)

If a 3.0 V Application Processor (DTE) is used, then it is recommended to connect the 1.8 V UART interface of the module (DCE) by means of appropriate unidirectional voltage translators using the module **V_INT** output as 1.8 V supply for the voltage translators on the module side, as described in Figure 57.

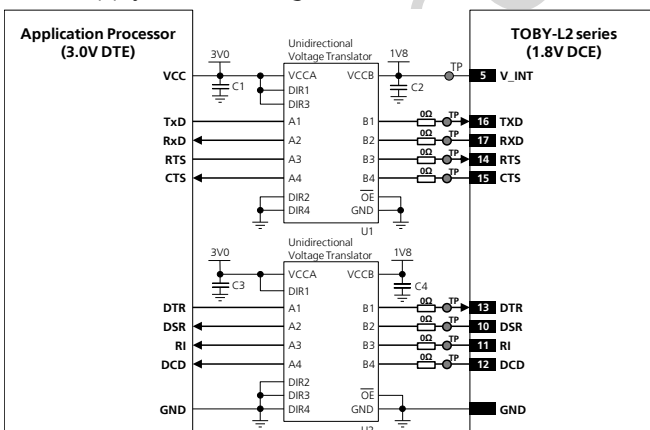

Figure 57: UART interface application circuit with complete V.24 link in DTE/DCE serial communication (3.0 V DTE)

Reference	Description	Part Number - Manufacturer
C1, C2, C3, C4	100 nF Capacitor Ceramic X7R 0402 10% 16 V	GRM155R61A104KA01 - Murata
U1, U2	Unidirectional Voltage Translator	SN74AVC4T774 - Texas Instruments

Table 34: Component for UART application circuit with complete V.24 link in DTE/DCE serial communication (3.0 V DTE)

Providing the TXD, RXD, RTS and CTS lines only (not using the complete V.24 link)

If the functionality of the **DSR**, **DCD**, **RI** and **DTR** lines is not required in, or the lines are not available:

- Connect the module **DTR** input line to GND using a 0 Ω series resistor, since the module requires **DTR** active
- Leave **DSR**, **DCD** and **RI** lines of the module unconnected and floating

If RS-232 compatible signal levels are needed, the Maxim 13234E voltage level translator can be used. This chip translates voltage levels from 1.8 V (module side) to the RS-232 standard.

If a 1.8 V Application Processor is used, the circuit should be implemented as described in Figure 58.

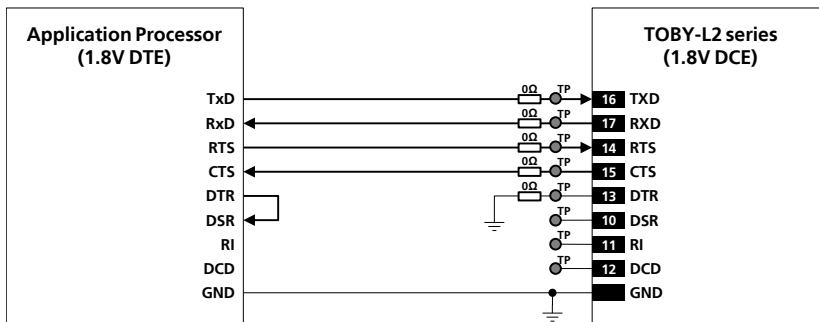

Figure 58: UART interface application circuit with partial V.24 link (5-wire) in the DTE/DCE serial communication (1.8V DTE)

If a 3.0 V Application Processor (DTE) is used, then it is recommended to connect the 1.8 V UART interface of the module (DCE) by means of appropriate unidirectional voltage translators using the module **V_INT** output as 1.8 V supply for the voltage translators on the module side, as described in Figure 59.

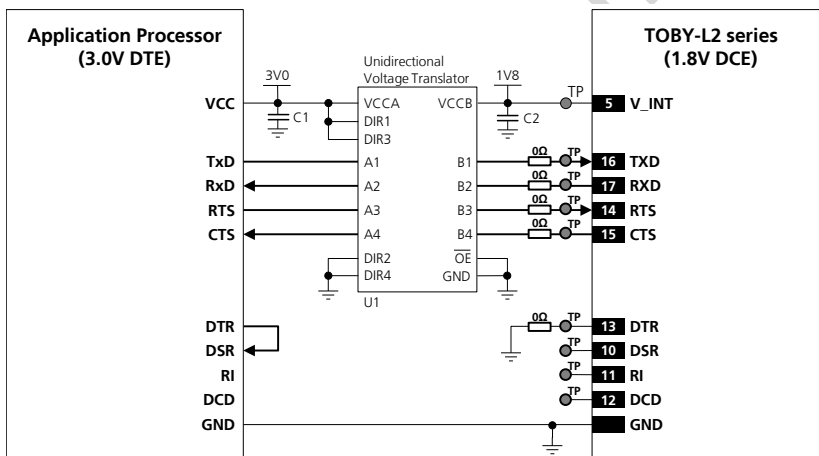

Figure 59: UART interface application circuit with partial V.24 link (5-wire) in DTE/DCE serial communication (3.0 V DTE)

Reference	Description	Part Number - Manufacturer
C1, C2	100 nF Capacitor Ceramic X7R 0402 10% 16 V	GRM155R61A104KA01 - Murata
U1	Unidirectional Voltage Translator	SN74AVC4T774 - Texas Instruments

Table 35: Component for UART application circuit with partial V.24 link (5-wire) in DTE/DCE serial communication (3.0 V DTE)

Providing the TXD and RXD lines only (not using the complete V24 link)

If the functionality of the **CTS**, **RTS**, **DSR**, **DCD**, **RI** and **DTR** lines is not required in the application, or the lines are not available, then:

- Connect the module **RTS** input line to GND or to the **CTS** output line of the module: since the module requires **RTS** active (low electrical level) if HW flow-control is enabled (AT&K3, that is the default setting), the pin can be connected using a 0 Ω series resistor to GND or to the active-module **CTS** (low electrical level) when the module is in active-mode, the UART interface is enabled and the HW flow-control is enabled
- Connect the module **DTR** input line to GND using a 0 Ω series resistor, as the module requires **DTR** active
- Leave **DSR**, **DCD** and **RI** lines of the module unconnected and floating

If RS-232 compatible signal levels are needed, the Maxim 13234E voltage level translator can be used. This chip translates voltage levels from 1.8 V (module side) to the RS-232 standard.

If a 1.8 V Application Processor (DTE) is used, the circuit that should be implemented as described in Figure 60

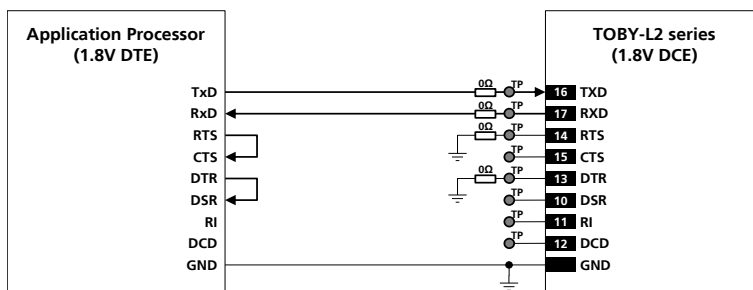

Figure 60: UART interface application circuit with partial V.24 link (3-wire) in the DTE/DCE serial communication (1.8V DTE)

If a 3.0 V Application Processor (DTE) is used, then it is recommended to connect the 1.8 V UART interface of the module (DCE) by means of appropriate unidirectional voltage translators using the module **V_INT** output as 1.8 V supply for the voltage translators on the module side, as described in Figure 61.

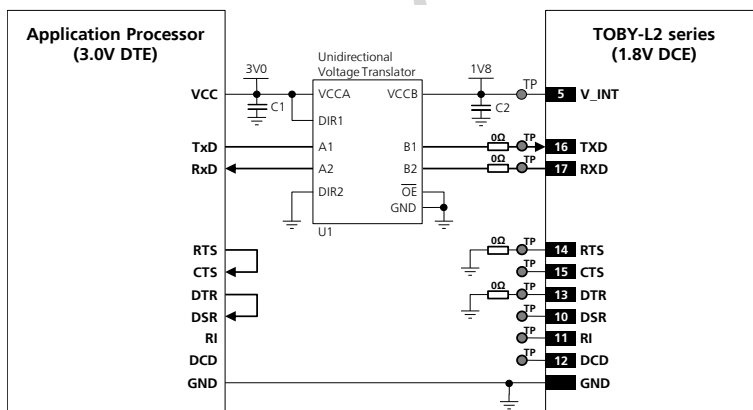

Figure 61: UART interface application circuit with partial V.24 link (3-wire) in DTE/DCE serial communication (3.0 V DTE)

Reference	Description	Part Number - Manufacturer
C1, C2	100 nF Capacitor Ceramic X7R 0402 10% 16 V	GRM155R61A104KA01 - Murata
U1	Unidirectional Voltage Translator	SN74AVC2T245 - Texas Instruments

Table 36: Component for UART application circuit with partial V.24 link (3-wire) in DTE/DCE serial communication (3.0 V DTE)

Additional considerations

If a 3.0 V Application Processor (DTE) is used, the voltage scaling from any 3.0 V output of the DTE to the corresponding 1.8 V input of the module (DCE) can be implemented as an alternative low-cost solution, by means of an appropriate voltage divider. Consider the value of the pull-up integrated at the input of the module (DCE) for the correct selection of the voltage divider resistance values and mind that any DTE signal connected to the module must be tri-stated or set low when the module is in power-down mode and during the module power-on sequence (at least until the activation of the **V_INT** supply output of the module), to avoid latch-up of circuits and allow a proper boot of the module (see the remark below).

Moreover, the voltage scaling from any 1.8 V output of the cellular module (DCE) to the corresponding 3.0 V input of the Application Processor (DTE) can be implemented by means of an appropriate low-cost non-inverting buffer with open drain output. The non-inverting buffer should be supplied by the **V_INT** supply output of the cellular module. Consider the value of the pull-up integrated at each input of the DTE (if any) and the baud rate required by the application for the appropriate selection of the resistance value for the external pull-up biased by the application processor supply rail.



If power saving is enabled the application circuit with the **TXD** and **RXD** lines only is not recommended. During command mode the DTE must send to the module a wake-up character or a dummy "AT" before each command line (see section 1.9.2.4 for the complete description), but during data mode the wake-up character or the dummy "AT" would affect the data communication.



Do not apply voltage to any UART interface pin before the switch-on of the UART supply source (**V_INT**), to avoid latch-up of circuits and allow a proper boot of the module. If the external signals connected to the cellular module cannot be tri-stated or set low, insert a multi channel digital switch (e.g. TI SN74CB3Q16244, TS5A3159, or TS5A63157) between the two-circuit connections and set to high impedance before **V_INT** switch-on.



ESD sensitivity rating of UART interface pins is 1 kV (Human Body Model according to JESD22-A114). Higher protection level could be required if the lines are externally accessible and it can be achieved by mounting an ESD protection (e.g. EPCOS CA05P4S14THSG varistor array) close to accessible points.



If the UART interface pins are not used, they can be left unconnected on the application board, but it is recommended providing accessible test points directly connected to all the UART pins (**TXD**, **RXD**, **RTS**, **CTS**, **DTR**, **DSR**, **DCD**, **RI**) for diagnostic purpose, in particular providing a 0 Ω series jumper on each line to detach each UART pin of the module from the DTE application processor.

2.6.2.2 Guidelines for UART layout design

The UART serial interface requires the same consideration regarding electro-magnetic interference as any other digital interface. Keep the traces short and avoid coupling with RF line or sensitive analog inputs, since the signals can cause the radiation of some harmonics of the digital data frequency.

2.6.3 DDC (I²C) interface



The I²C bus compatible Display Data Channel interface is not available on MPC1-L2 series modules.

2.6.3.1 Guidelines for DDC (I²C) circuit design



I²C bus function is not supported by TOBY-L2 "00", "01", and "50" product versions: the pins should not be driven by any external device.

General considerations

The DDC I²C-bus master interface can be used to communicate with u-blox GNSS receivers and other external I²C-bus slaves as an audio codec. Beside the general considerations reported below, see:

- the following parts of this section for specific guidelines for the connection to u-blox GNSS receivers
- the section 2.7.1 for an application circuit example with an external audio codec I²C-bus slave

To be compliant with the I²C bus specifications, the module bus interface pads are open drain output and pull up resistors must be mounted externally. Resistor values must conform to I²C bus specifications [12]: for example, 4.7 k Ω resistors can be commonly used. Pull-ups must be connected to a supply voltage of 1.8 V (typical), since this is the voltage domain of the DDC pins which are not tolerant to higher voltage values (e.g. 3.0 V).



Connect the DDC (I²C) pull-ups to the **V_INT** 1.8 V supply source, or another 1.8 V supply source enabled after **V_INT** (e.g., as the GNSS 1.8 V supply present in Figure 62 application circuit), as any external signal connected to the DDC (I²C) interface must not be set high before the switch-on of the **V_INT** supply of DDC pins, to avoid latch-up of circuits and let a proper boot of the module.

The signal shape is defined by the values of the pull-up resistors and the bus capacitance. Long wires on the bus will increase the capacitance. If the bus capacitance is increased, use pull-up resistors with nominal resistance value lower than 4.7 k Ω , to match the I²C bus specifications [12] regarding rise and fall times of the signals.



Capacitance and series resistance must be limited on the bus to match the I²C specifications (1.0 μ s is the maximum allowed rise time on the **SCL** and **SDA** lines): route connections as short as possible.



If the pins are not used as DDC bus interface, they can be left unconnected.



ESD sensitivity rating of the DDC (I²C) pins is 1 kV (Human Body Model according to JESD22-A114). Higher protection level could be required if the lines are externally accessible and it can be achieved by mounting an ESD protection (e.g. EPCOS CA05P4S14THSG varistor array) close to accessible points.

Figure 63 illustrates an alternative application circuit solution in which the TOBY-L2 supplies a u-blox 1.8 V GNSS receiver. The **V_INT** 1.8 V regulated supply output of a TOBY-L2 module can be used as supply source for a u-blox 1.8 V GNSS receiver (u-blox 6 generation receiver or newer) instead of using an external voltage regulator, as shown in Figure 62. The **V_INT** supply is able to support the maximum current consumption of these positioning receivers.

The internal switching step-down regulator that generates the **V_INT** supply is set to 1.8 V (typical) when the cellular module is switched on and it is disabled when the module is switched off.

The supply of the u-blox 1.8 V GNSS receiver can be switched off using an external p-channel MOS controlled by the **GPIO2** pin of TOBY-L2 cellular modules by means of a proper inverting transistor as shown in Figure 63, implementing the “GNSS supply enable” function. If this feature is not required, the **V_INT** supply output can be directly connected to the u-blox 1.8 V GNSS receiver, so that it will switch on when **V_INT** output is enabled.

According to the **V_INT** supply output voltage ripple characteristic specified in the TOBY-L2 Data Sheet [1]:

- Additional filtering may be needed to properly supply an external LNA, depending on the characteristics of the used LNA, adding a series ferrite bead and a bypass capacitor (e.g. the Murata BLM15HD182SN1 ferrite bead and the Murata GRM1555C1H220J 22 pF capacitor) at the input of the external LNA supply line

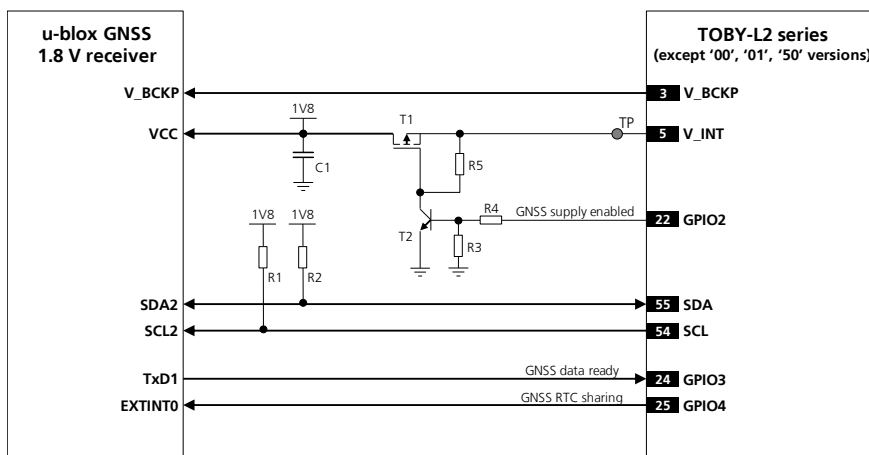

Figure 63: Application circuit for connecting TOBY-L2 modules to u-blox 1.8 V GNSS receivers using **V_INT** as supply

Reference	Description	Part Number - Manufacturer
R1, R2	4.7 kΩ Resistor 0402 5% 0.1 W	RC0402JR-074K7L - Yageo Phycomp
R3	47 kΩ Resistor 0402 5% 0.1 W	RC0402JR-0747KL - Yageo Phycomp
R4	10 kΩ Resistor 0402 5% 0.1 W	RC0402JR-0710KL - Yageo Phycomp
R5	100 kΩ Resistor 0402 5% 0.1 W	RC0402JR-07100KL - Yageo Phycomp
T1	P-Channel MOSFET Low On-Resistance	IRLML6401 - International Rectifier or NTZS3151P - ON Semi
T2	NPN BJT Transistor	BC847 - Infineon
C1	100 nF Capacitor Ceramic X7R 0402 10% 16 V	GRM155R71C104KA01 - Murata

Table 38: Components for connecting TOBY-L2 modules to u-blox 1.8 V GNSS receivers using **V_INT** as supply

For additional guidelines regarding the design of applications with u-blox 1.8 V GNSS receivers see the GNSS Implementation Application Note [13] and the Hardware Integration Manual of the u-blox GNSS receivers.

Connection with u-blox 3.0 V GNSS receivers

Figure 64 shows an application circuit for connecting TOBY-L2 cellular modules to a u-blox 3.0 V GNSS receiver:

- As the **SDA** and **SCL** pins of the TOBY-L2 cellular module are not tolerant up to 3.0 V, the connection to the related I²C pins of the u-blox 3.0 V GNSS receiver must be provided using a proper I²C-bus Bidirectional Voltage Translator with proper pull-up resistors (e.g. the TI TCA9406 additionally provides the partial power down feature so that the GNSS 3.0 V supply can be ramped up before the **V_INT** 1.8 V cellular supply).
- As the **GPIO3** and **GPIO4** pins of the TOBY-L2 cellular module are not tolerant up to 3.0 V, the connection to the related pins of the u-blox 3.0 V GNSS receiver must be provided using a proper Unidirectional General Purpose Voltage Translator (e.g. TI SN74AVC2T245, which additionally provides the partial power down feature so that the 3.0 V GNSS supply can be also ramped up before the **V_INT** 1.8 V cellular supply).
- GPIO2** pin is connected to the shutdown input pin (**SHDNn**) of the LDO regulators providing the 3.0 V supply rail for the u-blox 3.0 V GNSS receiver implementing the “GNSS enable” function, with appropriate pull-down resistor mounted on **GPIO2** line to avoid an improper switch on of the u-blox GNSS receiver.
- The **V_BCKP** supply output of the cellular module can be directly connected to the **V_BCKP** backup supply input pin of the GNSS receiver as in the application circuit for a u-blox 1.8 V GNSS receiver.

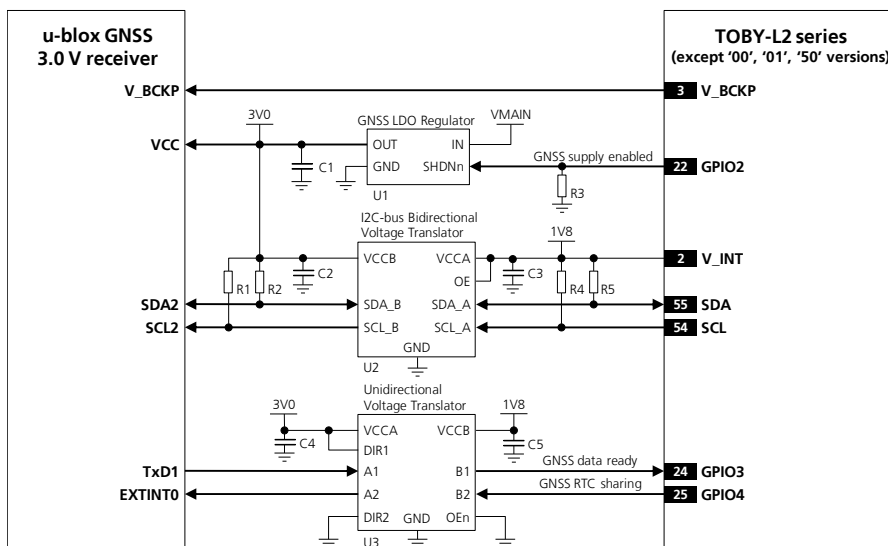

Figure 64: Application circuit for connecting TOBY-L2 modules to u-blox 3.0 V GNSS receivers

Reference	Description	Part Number - Manufacturer
R1, R2, R4, R5	4.7 kΩ Resistor 0402 5% 0.1 W	RC0402JR-074K7L - Yageo Phycomp
R3	47 kΩ Resistor 0402 5% 0.1 W	RC0402JR-0747KL - Yageo Phycomp
C2, C3, C4, C5	100 nF Capacitor Ceramic X5R 0402 10% 10V	GRM155R71C104KA01 - Murata
U1, C1	Voltage Regulator for GNSS receiver and capacitor	See GNSS receiver Hardware Integration Manual
U2	I2C-bus Bidirectional Voltage Translator	TCA9406DCUR - Texas Instruments
U3	Generic Unidirectional Voltage Translator	SN74AVC2T245 - Texas Instruments

Table 39: Components for connecting TOBY-L2 modules to u-blox 3.0 V GNSS receivers

For additional guidelines regarding the design of applications with u-blox 3.0 V GNSS receivers see the GNSS Implementation Application Note [13] and the Hardware Integration Manual of the u-blox GNSS receivers.

2.6.3.2 Guidelines for DDC (I²C) layout design

The DDC (I²C) serial interface requires the same consideration regarding electro-magnetic interference as any other digital interface. Keep the traces short and avoid coupling with RF line or sensitive analog inputs, since the signals can cause the radiation of some harmonics of the digital data frequency.

2.6.4 Secure Digital Input Output interface (SDIO)



The SDIO Secure Digital Input Output interface is not available on MPC1-L2 series modules.

2.6.4.1 Guidelines for SDIO circuit design



The functionality of the SDIO Secure Digital Input Output interface pins is not supported by TOBY-L2 “00” and “01” product versions: the pins should not be driven by any external device.

TOBY-L2 series modules include a 4-bit Secure Digital Input Output interface (**SDIO_D0**, **SDIO_D1**, **SDIO_D2**, **SDIO_D3**, **SDIO_CLK**, **SDIO_CMD**) designed to communicate with an external u-blox short range Wi-Fi module.

Combining a u-blox cellular module with a u-blox short range communication module gives designers full access to the Wi-Fi module directly via the cellular module, so that a second interface connected to the Wi-Fi module is not necessary. AT commands via the AT interfaces of the cellular module (UART, USB) allows full control of the Wi-Fi module from any host processor, because Wi-Fi control messages are relayed to the Wi-Fi module via the dedicated SDIO interface (for more details, see the Wi-Fi AT commands in the u-blox AT Commands Manual [3] and see the Wi-Fi / Cellular Integration Application Note [14]).

Figure 65 and Table 40 show an application circuit for connecting TOBY-L2 series cellular modules “50” product version to u-blox ELLA-W1 series short range Wi-Fi 802.11 b/g/n modules:

- The SDIO pins of the cellular module are connected to the related SDIO pins of the u-blox ELLA-W1 series short range Wi-Fi module, with appropriate low value series damping resistors to avoid reflections and other losses in signal integrity, which may create ringing and loss of a square wave shape.
The most appropriate value for the series damping resistors on the SDIO lines depends on the specific line lengths and layout implemented. In general, the SDIO series resistors are not strictly required, but it is recommended to slow the SDIO signal, for example with 22 Ω or 33 Ω resistors, and avoid any possible ringing problem without violating the rise / fall time requirements.
- The **V_INT** supply output pin of the cellular module is connected to the shutdown input pin (**SHDNn**) of the two LDO regulators providing the 3.3 V and 1.8 V supply rails for the u-blox ELLA-W1 series Wi-Fi module, with appropriate pull-down resistors to avoid an improper switch on of the Wi-Fi module before the switch-on of the **V_INT** supply source of the cellular module SDIO interface pins.
- The **GPIO1** pin of the cellular module is connected to the active low full power down input pin (**PDn**) of the u-blox ELLA-W1 series Wi-Fi module, implementing the Wi-Fi enable function.
- The configuration pin (**CFG**) of the u-blox ELLA-W1 series Wi-Fi module is connected to ground by means of a proper pull-down resistor for operation without sleep clock.
The sleep clock input pin (**SLEEP_CLK**) of the u-blox ELLA-W1 series Wi-Fi module is left not connected, because an external clock source is not required for full power mode and automotive use.
- The WLAN LED open drain output pin (**LED_0**) of the u-blox ELLA-W1 series Wi-Fi module is connected to an LED with appropriate current limiting resistor, indicating Wi-Fi activity as additional optional feature.
- The WLAN antenna RF input/output (**ANT1**) of the u-blox ELLA-W1 series Wi-Fi module is connected to a Wi-Fi antenna with an appropriate series Wi-Fi band-pass filter specifically designed for the coexistence between the Wi-Fi RF signals (2402...2482 MHz) and the LTE band 7 RF signals (2500...2690 MHz), as for example the Wi-Fi BAW band-pass filter TDK EPCOS B9604, or the TriQuint 885071, or the TriQuint 885032 or the Avago ACPF-7424, or the Taiyo Yuden F6HF2G441AF46.
- All **GND** pins of the cellular module and the u-blox ELLA-W1 series Wi-Fi module are connected to ground.
- All the other pins of the u-blox ELLA-W1 series Wi-Fi module are intended to be not connected.

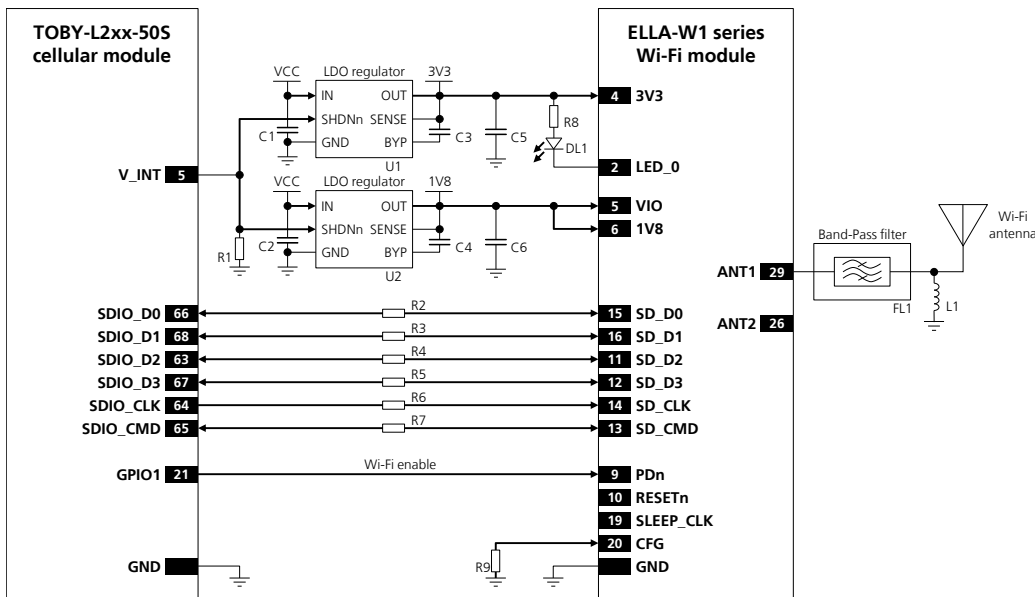
Figure 65: Application circuit for connecting TOBY-L2xx-50S cellular modules to u-blox ELLA-W1 series Wi-Fi modules

Reference	Description	Part Number - Manufacturer
C1, C2	1 μ F Capacitor Ceramic X7R 0603 10% 25 V	GRM188R71E105KA12 - Murata
C3, C4	10 nF Capacitor Ceramic X7R 0402 10% 16 V	GRM155R71C103KA01 - Murata
C5, C6	10 μ F Capacitor Ceramic X5R 0603 20% 6.3 V	GRM188R60J106ME47 - Murata
DL1	LED Green SMT 0603	LTST-C190KGKT - Lite-on Technology Corporation
FL1	WLAN band-pass filter with LTE Band 7 coexistence	B39242B9604P810 - TDK EPCOS
L1	15 nH Multilayer Inductor 0603 3% 0.25 A	MLG0603P15NHT000 - TDK
R1	470 k Ω Resistor 0402 5% 0.1 W	RK73B1ETTD474J - KOA
R2, R3, R4, R5, R6, R7	22 Ω Resistor 0402 5% 0.1 W	RK73B1ETTP220J - KOA
R8	470 Ω Resistor 0402 5% 0.1 W	RK73B1ETTP471J - KOA
R9	47 k Ω Resistor 0402 5% 0.1 W	RK73B1ETTD473J - KOA
U1	LDO Linear Regulator 3.0 V 0.3 A	LT1962EMS8-3.3 - Linear Technology
U2	LDO Linear Regulator 1.8 V 0.3 A	LT1962EMS8-1.8 - Linear Technology

Table 40: Components for connecting TOBY-L2xx-50S cellular modules to u-blox ELLA-W1 series Wi-Fi modules

Do not apply voltage to any SDIO interface pin before the switch-on of SDIO interface supply source (**V_INT**), to avoid latch-up of circuits and allow a proper boot of the module.



ESD sensitivity rating of SDIO interface pins is 1 kV (HMB according to JESD22-A114). Higher protection level could be required if the lines are externally accessible and it can be achieved by mounting a very low capacitance ESD protection (e.g. Tyco Electronics PESD0402-140 ESD), close to accessible points.



If the SDIO interface pins are not used, they can be left unconnected on the application board.

2.6.4.2 Guidelines for SDIO layout design

The SDIO serial interface requires the same consideration regarding electro-magnetic interference as any other high speed digital interface.

Keep the traces short, avoid stubs and avoid coupling with RF lines / parts or sensitive analog inputs, since the signals can cause the radiation of some harmonics of the digital data frequency.

Consider the usage of low value series damping resistors (see the application circuit in Figure 65 / Table 40) to avoid reflections and other losses in signal integrity, which may create ringing and loss of a square wave shape.

2.7 Audio interface

2.7.1 Digital audio interface

 The I²S interface is not available on MPC1-L2 series modules.

2.7.1.1 Guidelines for digital audio circuit design

 The I²S interface is not supported by TOBY-L2 “00”, “01”, and “50” product versions: the pins should not be driven by any external device.

I²S digital audio interface can be connected to an external digital audio device for voice applications. The external digital audio device must be properly configured according to the cellular module configuration, with the opposite role, the same mode, the same sample rate and voltage level.

Any external digital audio device compliant with the configuration of the digital audio interface of the TOBY-L2 cellular module can be used. Examples of compatible audio codec parts, suitable to provide analog audio voice capability on the application device, are the following:

- Marvell 88PM805
- Maxim MAX9860
- Maxim MAX9867
- Maxim MAX9880A

An appropriate specific application circuit has to be implemented and configured according to the particular external digital audio device or audio codec used and according to the application requirements.

Figure 66 and Table 41 describe an application circuit for the I²S digital audio interface providing voice capability using an external audio voice codec. DAC and ADC integrated in the external audio codec respectively converts an incoming digital data stream to analog audio output through a mono amplifier and converts the microphone input signal to the digital bit stream over the digital audio interface.

The module's I²S interface (I²S master) is connected to the related pins of the external audio codec (I²S slave).

The **GPIO6** of the TOBY-L2 series module (that provides a suitable digital output clock) is connected to the clock input of the external audio codec to provide clock reference.

The external audio codec is controlled by the wireless module using the DDC (I²C) interface: this interface can be concurrently used to communicate with u-blox GNSS receivers and to control an external audio codec.

The **V_INT** output supplies the external audio codec, defining proper digital interfaces voltage level.

Additional components are provided for EMC and ESD immunity conformity: a 10 nF bypass capacitor and a series chip ferrite bead noise/EMI suppression filter provided on each microphone line input and speaker line output of the external codec as described in Figure 66 and Table 41. The necessity of these or other additional parts for EMC improvement may depend on the specific application board design.

As various external audio codecs other than the one described in Figure 66 / Table 41 can be used to provide voice capability, the appropriate specific application circuit has to be implemented and configured according to the particular external digital audio device or audio codec used and according to the application requirements.

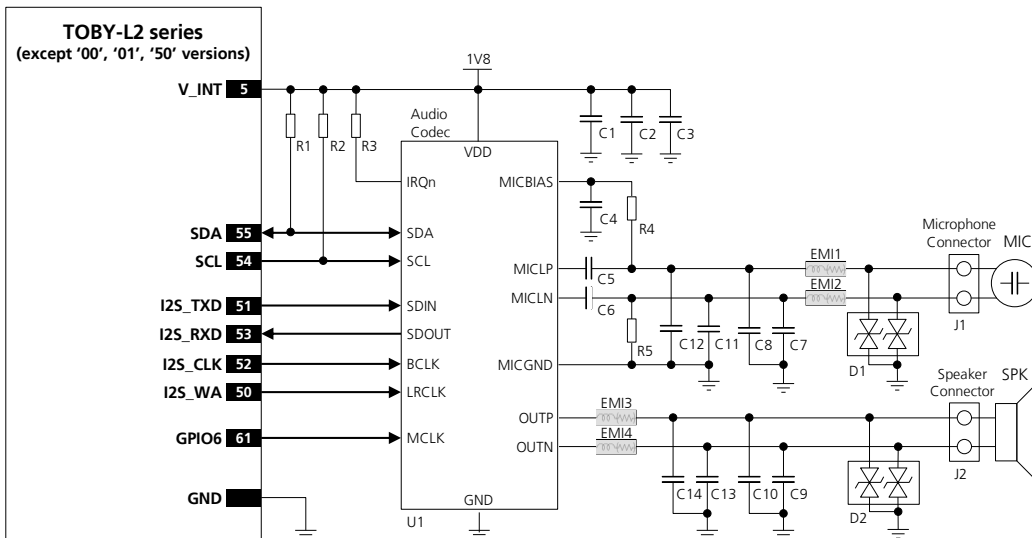

Figure 66: I²S interface application circuit with an external audio codec to provide voice capability

Reference	Description	Part Number – Manufacturer
C1	100 nF Capacitor Ceramic X5R 0402 10% 10V	GRM155R71C104KA01 – Murata
C2, C4, C5, C6	1 μF Capacitor Ceramic X5R 0402 10% 6.3 V	GRM155R60J105KE19 – Murata
C3	10 μF Capacitor Ceramic X5R 0603 20% 6.3 V	GRM188R60J106ME47 – Murata
C7, C8, C9, C10	27 pF Capacitor Ceramic COG 0402 5% 25 V	GRM1555C1H270JZ01 – Murata
C11, C12, C13, C14	10 nF Capacitor Ceramic X5R 0402 10% 50V	GRM155R71C103KA88 – Murata
D1, D2	Low Capacitance ESD Protection	USB0002RP or USB0002DP – AVX
EMI1, EMI2, EMI3, EMI4	Chip Ferrite Bead Noise/EMI Suppression Filter 1800 Ohm at 100 MHz, 2700 Ohm at 1 GHz	BLM15HD182SN1 – Murata
J1	Microphone Connector	Various manufacturers
J2	Speaker Connector	Various manufacturers
MIC	2.2 kΩ Electret Microphone	Various manufacturers
R1, R2	4.7 kΩ Resistor 0402 5% 0.1 W	RC0402JR-074K7L - Yageo Phycomp
R3	10 kΩ Resistor 0402 5% 0.1 W	RC0402JR-0710KL - Yageo Phycomp
R4, R5	2.2 kΩ Resistor 0402 5% 0.1 W	RC0402JR-072K2L – Yageo Phycomp
SPK	32 Ω Speaker	Various manufacturers
U1	16-Bit Mono Audio Voice Codec	MAX9860ETG+ - Maxim

Table 41: Example of components for audio voice codec application circuit



Do not apply voltage to any I²S pin before the switch-on of I²S supply source (**V_INT**), to avoid latch-up of circuits and allow a proper boot of the module. If the external signals connected to the cellular module cannot be tri-stated or set low, insert a multi channel digital switch (e.g. TI SN74CB3Q16244, TS5A3159, or TS5A63157) between the two-circuit connections and set to high impedance before **V_INT** switch-on.



ESD sensitivity rating of I²S interface pins is 1 kV (Human Body Model according to JESD22-A114). Higher protection level could be required if the lines are externally accessible and it can be achieved by mounting a general purpose ESD protection (e.g. EPCOS CA05P4S14THSG varistor array) close to accessible points.



If the I²S digital audio pins are not used, they can be left unconnected on the application board.

2.7.1.2 Guidelines for digital audio layout design

I²S interface and clock output lines require the same consideration regarding electro-magnetic interference as any other high speed digital interface. Keep the traces short and avoid coupling with RF lines / parts or sensitive analog inputs, since the signals can cause the radiation of some harmonics of the digital data frequency.

2.8 General Purpose Input/Output

GPIOs are not supported by TOBY-L2 “00”, “01”, and “50” product versions, except for the WWAN status indication configured on **GPIO1** of “00”, “01” product versions and the Wi-Fi enable function configured on **GPIO1** of “50” product version: the pins should not be driven by any external device.

GPIOs are not available on MPC1-L2 series modules.

2.8.1.1 Guidelines for TOBY-L2 series GPIO circuit design

A typical usage of TOBY-L2 modules’ GPIOs can be the following:

- Network indication provided over **GPIO1** pin (see Figure 67 / Table 42 below)
- GNSS supply enable provided over **GPIO2** (see Figure 62 / Table 37 or Figure 64 / Table 39 in section 2.6.3)
- GNSS data ready provided over **GPIO3** (see Figure 62 / Table 37 or Figure 64 / Table 39 in section 2.6.3)
- GNSS RTC sharing provided over **GPIO4** (see Figure 62 / Table 37 or Figure 64 / Table 39 in section 2.6.3)
- SIM card detection provided over **GPIO5** (see Figure 51 / Table 31 or Figure 52 / Table 32 in section 2.5)
- Clock output provided over **GPIO6** (see Figure 66 / Table 41 in section 2.7.1)

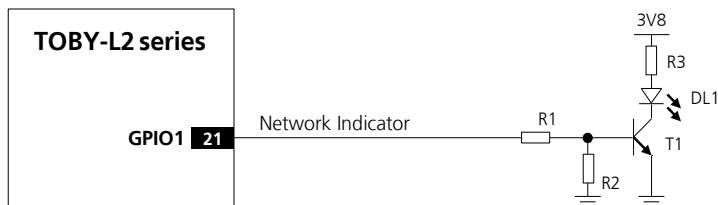

Figure 67: Application circuit for network indication provided over GPIO1

Reference	Description	Part Number - Manufacturer
R1	10 kΩ Resistor 0402 5% 0.1 W	Various manufacturers
R2	47 kΩ Resistor 0402 5% 0.1 W	Various manufacturers
R3	820 Ω Resistor 0402 5% 0.1 W	Various manufacturers
DL1	LED Red SMT 0603	LTST-C190KRKT - Lite-on Technology Corporation
T1	NPN BJT Transistor	BC847 - Infineon

Table 42: Components for network indication application circuit

Use transistors with at least an integrated resistor in the base pin or otherwise put a 10 kΩ resistor on the board in series to the GPIO of TOBY-L2 modules.

Do not apply voltage to any GPIO of TOBY-L2 before the switch-on of the GPIOs supply (**V_INT**), to avoid latch-up of circuits and allow a proper module boot. If the external signals connected to the module cannot be tri-stated or set low, insert a multi channel digital switch (e.g. TI SN74CB3Q16244, TS5A3159, TS5A63157) between the two-circuit connections and set to high impedance before **V_INT** switch-on.

ESD sensitivity rating of the GPIO pins is 1 kV (Human Body Model according to JESD22-A114). Higher protection level could be required if the lines are externally accessible and it can be achieved by mounting an ESD protection (e.g. EPCOS CA05P4S14THSG varistor array) close to accessible points.

If the GPIO pins are not used, they can be left unconnected on the application board.

2.8.1.2 Guidelines for general purpose input/output layout design

The general purpose inputs / outputs pins are generally not critical for layout.

2.9 Mini PCIe specific signals (**W_DISABLE#**, **LED_WWAN#**)



Mini PCI Express specific signals (**W_DISABLE#**, **LED_WWAN#**) are not available on TOBY-L2 series.

2.9.1.1 Guidelines for **W_DISABLE#** circuit design

As described in Figure 68, the MPC1-L2 series modules **W_DISABLE#** wireless disable input is equipped with an internal pull-up to the **3.3Vaux** supply: an external pull-up resistor is not required and should not be provided.

If connecting the **W_DISABLE#** input to a push button, the pin will be externally accessible on the application device. According to EMC/ESD requirements of the application, an additional ESD protection device should be provided close to accessible point, as described in Figure 68 and Table 43.



ESD sensitivity rating of the **W_DISABLE#** pin is 1 kV (HBM according to JESD22-A114). Higher protection level can be required if the line is externally accessible on the application board, e.g. if an accessible push button is directly connected to the **W_DISABLE#** pin, and it can be achieved by mounting an ESD protection (e.g. EPCOS CA05P4S14THSG varistor) close to accessible point.

An open drain output is suitable to drive the **W_DISABLE#** input from an application processor as it is equipped with an internal pull-up to the **3.3Vaux** supply as described in Figure 68.

A compatible push-pull output of an application processor can also be used. In any case, take care to set the proper level in all the possible scenarios to avoid an inappropriate disabling of the radio operations.

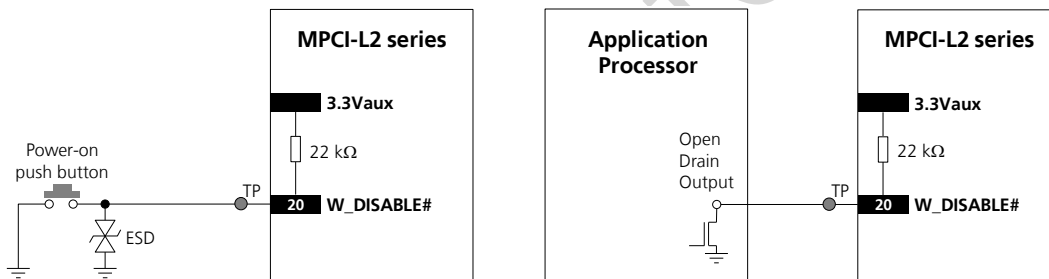

Figure 68: **W_DISABLE#** application circuit using a push button and an open drain output of an application processor

Reference	Description	Remarks
ESD	Varistor for ESD protection	CT0402S14AHSG - EPCOS

Table 43: Example of ESD protection component for the **W_DISABLE#** application circuit



If the **W_DISABLE#** functionality is not required by the application, the pin can be left unconnected.

2.9.1.2 Guidelines for LED_WWAN# circuit design

As described in Figure 69 and Table 44, the MPC-I-L2 series modules **LED_WWAN#** active-low open drain output can be directly connected to a system-mounted LED to provide the Wireless Wide Area Network status indication as specified by the PCI Express Mini Card Electromechanical Specification [15].

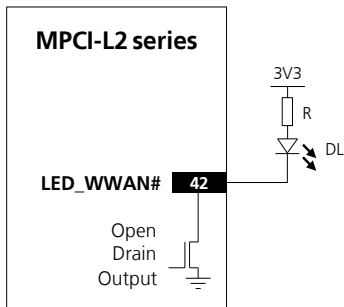

Figure 69: LED_WWAN# application circuit

Reference	Description	Remarks
DL	LED Green SMT 0603	LTST-C190KGKT - Lite-on Technology Corporation
R	470 Ω Resistor 0402 5% 0.1 W	Various manufacturers

Table 44: Example of components for the LED_WWAN# application circuit

- ESD sensitivity rating of the **LED_WWAN#** pin is 1 kV (Human Body Model according to JESD22-A114). Higher protection level could be required if the line is externally accessible and it can be achieved by mounting an ESD protection (e.g. EPCOS CA05P4S14THSG varistor) close to accessible point.
- If the **LED_WWAN#** functionality is not required by the application, the pin can be left unconnected.

2.9.1.3 Guidelines for W_DISABLE# and LED_WWAN# layout design

The **W_DISABLE#** and **LED_WWAN#** circuits are generally not critical for layout.

2.10 Reserved pins (RSVD)

- Pins reserved for future use, marked as **RSVD**, are not available on MPC-I-L2 series.

TOBY-L2 series modules have pins reserved for future use. All the **RSVD** pins are to be left unconnected on the application board except the **RSVD** pin number 6 which must be connected to ground as described in Figure 70.

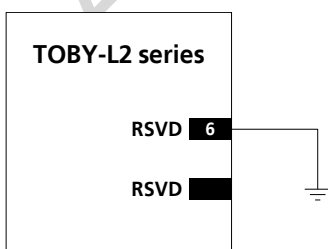

Figure 70: Application circuit for the reserved pins (RSVD)

2.11 Module placement

An optimized placement allows a minimum RF line's length and closer path from DC source for **VCC / 3.3Vaux**.

Make sure that the module, analog parts and RF circuits are clearly separated from any possible source of radiated energy. In particular, digital circuits can radiate digital frequency harmonics, which can produce Electro-Magnetic Interference that affects the module, analog parts and RF circuits' performance. Implement proper countermeasures to avoid any possible Electro-Magnetic Compatibility issue.

Make sure that the module, RF and analog parts / circuits, and high speed digital circuits are clearly separated from any sensitive part / circuit which may be affected by Electro-Magnetic Interference, or employ countermeasures to avoid any possible Electro-Magnetic Compatibility issue.

Provide enough clearance between the module and any external part.



The heat dissipation during continuous transmission at maximum power can significantly raise the temperature of the application base-board below the TOBY-L2 and MPC1-L2 series modules: avoid placing temperature sensitive devices close to the module.

Advance Information

2.12 TOBY-L2 series module footprint and paste mask

Figure 71 and Table 45 describe the suggested footprint (i.e. copper mask) layout for TOBY-L2 series modules. The proposed land pattern layout slightly reflects the modules' pads layout, with most of the lateral pads designed wider on the application board (1.8 x 0.8 mm) than on the module (1.5 x 0.8 mm).

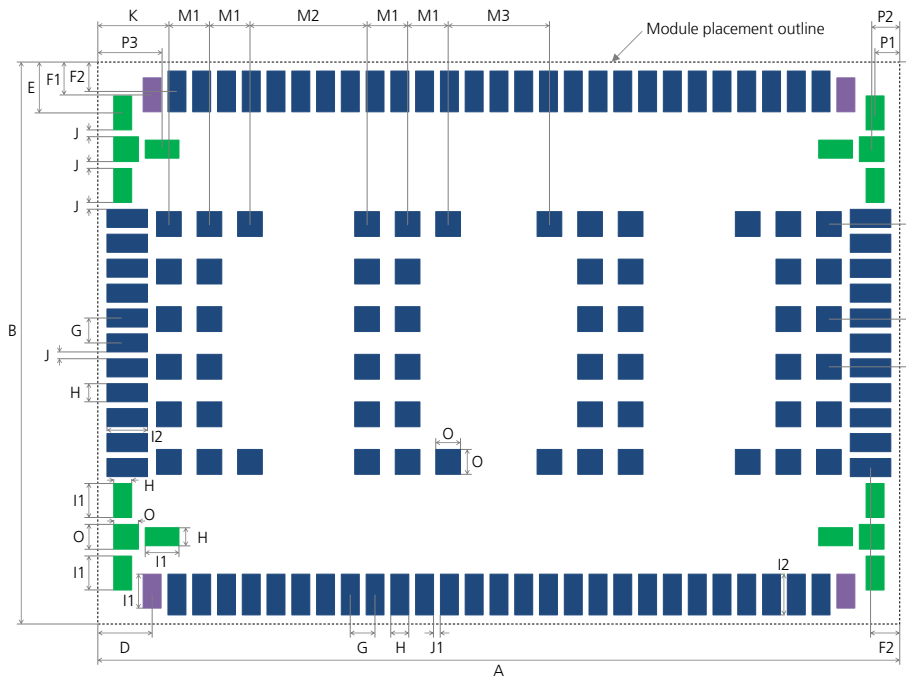

Figure 71: TOBY-L2 series module suggest footprint (application board top view)

Parameter	Value	Parameter	Value	Parameter	Value
A	35.6 mm	H	0.80 mm	M2	5.20 mm
B	24.8 mm	I1	1.50 mm	M3	4.50 mm
D	2.40 mm	I2	1.80 mm	N	2.10 mm
E	2.25 mm	J	0.30 mm	O	1.10 mm
F1	1.45 mm	K	3.15 mm	P1	1.10 mm
F2	1.30 mm	L	7.15 mm	P2	1.25 mm
G	1.10 mm	M1	1.80 mm	P3	2.85 mm

Table 45: TOBY-L2 series module suggest footprint dimensions

The Non Solder Mask Defined (NSMD) pad type is recommended over the Solder Mask Defined (SMD) pad type, implementing the solder mask opening 50 μ m larger per side than the corresponding copper pad.

The suggested paste mask layout for TOBY-L2 series modules slightly reflects the copper mask layout described in Figure 71 and Table 45, as different stencil apertures layout for any specific pad is recommended:

- Blue marked pads: Paste layout reduced circumferentially about 0.025 mm to Copper layout
- Green marked pads: Paste layout enlarged circumferentially about 0.025 mm to Copper layout
- Purple marked pads: Paste layout one to one to Copper layout

The recommended solder paste thickness is 150 μ m, according to application production process requirements.



These are recommendations only and not specifications. The exact mask geometries, distances and stencil thicknesses must be adapted to the specific production processes (e.g. soldering etc.) of the customer.

2.13 MPC1-L2 series module installation

MPC1-L2 series modules are fully compliant with the 52-pin PCI Express Full-Mini Card Type F2 form factor, i.e., top-side and bottom-side keep-out areas, 50.95 mm nominal length, 30 mm nominal width, and all the other dimensions as defined by the PCI Express Mini Card Electromechanical Specification [15], except for the card thickness (which nominal value is 3.7 mm), as described in Figure 72.

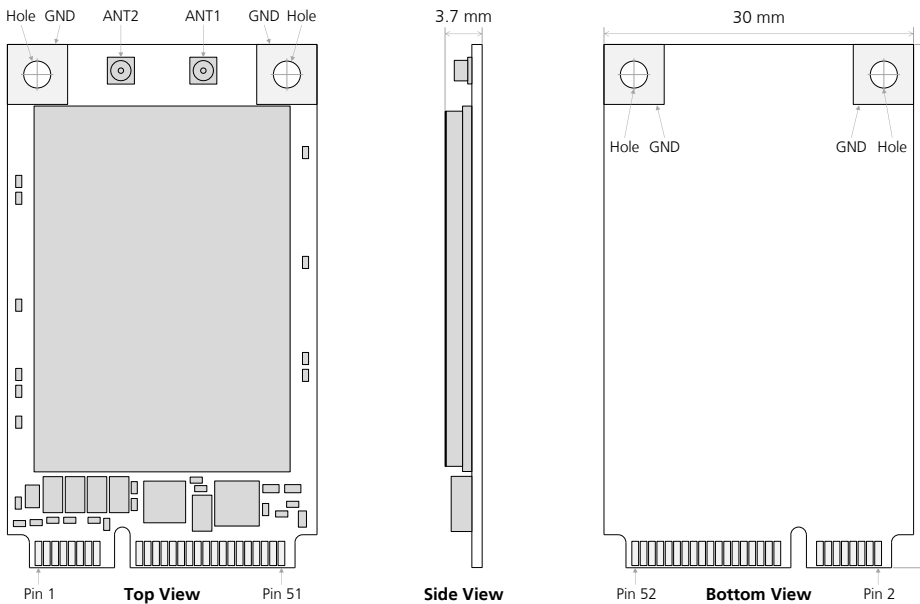

Figure 72: MPC1-L2 series mechanical description (top, side and bottom views)

MPC1-L2 series modules are fully compliant with the 52-pin PCI Express Full-Mini card edge type system connector as defined by the PCI Express Mini Card Electromechanical Specification [15]. Table 46 describes some examples of 52-pin mating system connectors for the MPC1-L2 series PCI Express Full-Mini card modules.

Manufacturer	Part Number	Description
JAE Electronics	MM60 series	52-circuit, 0.8 mm pitch, PCI Express Mini card edge female connector
Molex	67910 series	52-circuit, 0.8 mm pitch, PCI Express Mini card edge female connector
TE Connectivity / AMP	2041119 series	52-circuit, 0.8 mm pitch, PCI Express Mini card edge female connector
FCI	10123824 series	52-circuit, 0.8 mm pitch, PCI Express Mini card edge female connector

Table 46: MPC1-L2 series PCI Express Full-Mini card compatible connector



It is recommended to use the two mounting holes described in Figure 72 to fix (ground) the MPC1-L2 module to the main ground of the application board with suitable screws and fasteners.



Follow the recommendations provided by the connector manufacturer and the guidelines available in the PCI Express Mini Card Electromechanical Specification [15] for the development of the footprint (i.e. the copper mask) PCB layout for the mating edge system connector. The exact geometries, distances and stencil thicknesses should be adapted to the specific production processes (e.g. soldering etc.).



Follow the recommendations provided by the connector manufacturer to properly insert and remove the MPC1-L2 series modules.

MPC1-L2 series modules are equipped with two Hirose U.FL-R-SMT RF receptacles for **ANT1 / ANT2** ports, which require a suitable mated RF plug from the same connector series as the examples listed in Table 24.

To mate the connectors, the mating axes of both connectors must be aligned. The "click" will confirm the fully mated connection. Do not attempt to insert on an extreme angle: insert the RF plug connectors vertically into the **ANT1 / ANT2** RF receptacles of the modules, as described in Figure 73.

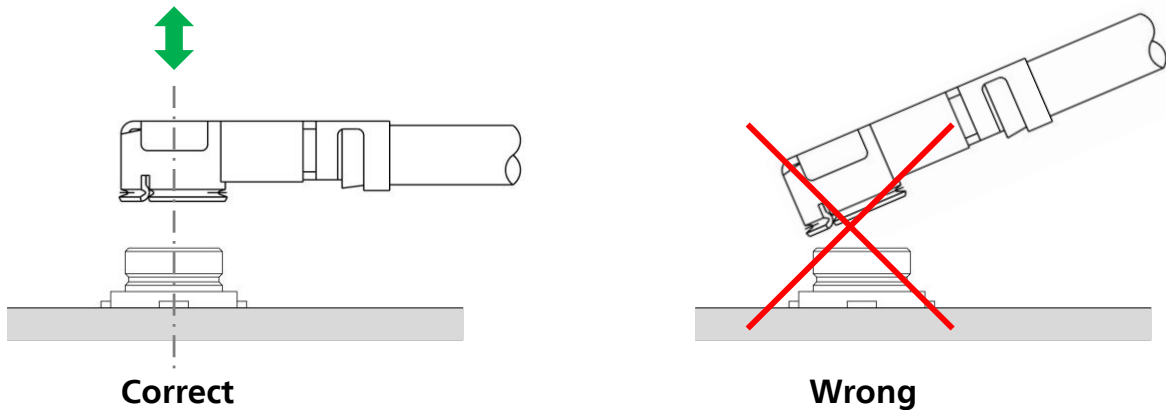

Figure 73: Precautions during RF connector mating

To unplug the RF cable assembly it is encouraged to use a suitable extraction tool for the RF connector, such as the Hirose U.FL-LP-N or the Hirose U.FL-LP(V)-N extraction jig, according to the RF cable assembly type used. Hook the end portion of the extraction jig onto the connector cover and pull off vertically in the direction of the connector mating axis, as described in Figure 74.

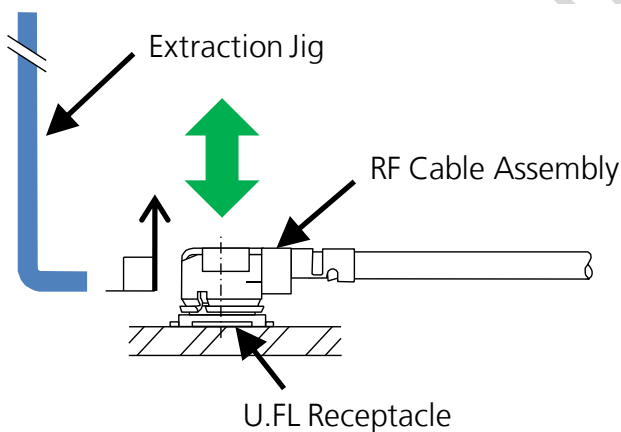

Figure 74: Precautions during RF connector extraction

Any attempt to unplug the RF connectors by pulling on the cable assembly without using a suitable extraction tool may result in damage and affect the RF performance.

Do not forcefully twist, deform, or apply any excessive pull force to the RF cables or damage the RF connectors, otherwise the RF performance may be reduced.

2.14 Thermal guidelines



Modules' operating temperature range is specified in TOBY-L2 Data Sheet [1] and MPCI-L2 Data Sheet [2].

The most critical condition concerning module thermal performance is the uplink transmission at maximum power (data upload in connected-mode), when the baseband processor runs at full speed, radio circuits are all active and the RF power amplifier is driven to higher output RF power. This scenario is not often encountered in real networks (for example, see the Terminal Tx Power distribution for WCDMA, taken from operation on a live network, described in the GSMA TS.09 Battery Life Measurement and Current Consumption Technique [21]); however the application should be correctly designed to cope with it.

During transmission at maximum RF power the TOBY-L2 and MPCI-L2 series modules generate thermal power that may exceed 3 W: this is an indicative value since the exact generated power strictly depends on operating condition such as the actual antenna return loss, the number of allocated TX resource blocks, the transmitting frequency band, etc. The generated thermal power must be adequately dissipated through the thermal and mechanical design of the application.

The spreading of the Module-to-Ambient thermal resistance ($R_{th,M-A}$) depends on the module operating condition. The overall temperature distribution is influenced by the configuration of the active components during the specific mode of operation and their different thermal resistance toward the case interface.



The Module-to-Ambient thermal resistance value and the relative increase of module temperature will differ according to the specific mechanical deployments of the module, e.g. application PCB with different dimensions and characteristics, mechanical shells enclosure, or forced air flow.

The increase of the thermal dissipation, i.e. the reduction of the Module-to-Ambient thermal resistance, will decrease the temperature of the modules' internal circuitry for a given operating ambient temperature. This improves the device long-term reliability in particular for applications operating at high ambient temperature.

A few hardware techniques may be used to reduce the Module-to-Ambient thermal resistance in the application:

- Connect each **GND** pin with solid ground layer of the application board and connect each ground area of the multilayer application board with complete thermal via stacked down to main ground layer.
- Use the two mounting holes described in Figure 72 to fix (ground) the MPCI-L2 modules to the main ground of the application board with suitable screws and fasteners.
- Provide a ground plane as wide as possible on the application board.
- Optimize antenna return loss, to optimize overall electrical performance of the module including a decrease of module thermal power.
- Optimize the thermal design of any high-power components included in the application, such as linear regulators and amplifiers, to optimize overall temperature distribution in the application device.
- Select the material, the thickness and the surface of the box (i.e. the mechanical enclosure) of the application device that integrates the module so that it provides good thermal dissipation.
- Force ventilation air-flow within mechanical enclosure.
- Provide a heat sink component attached to the module top side, with electrically insulated / high thermal conductivity adhesive, or on the backside of the application board, below the cellular module, as a large part of the heat is transported through the GND pads of the TOBY-L2 series LGA modules and dissipated over the backside of the application board.
- Follow the thermal guidelines for integrating wireless wide area network mini card add-in cards, such as the MPCI-L2 series modules, as provided in the PCI Express Mini Card Electromechanical Specification [15]

For example, the Module-to-Ambient thermal resistance ($R_{th,M-A}$) is strongly reduced with forced air ventilation and a heat-sink installed on the back of the application board, decreasing the module temperature variation.

Beside the reduction of the Module-to-Ambient thermal resistance implemented by proper application hardware design, the increase of module temperature can be moderated by proper application software implementation:

- Enable power saving configuration using the AT+UPSV command (see section 1.15.18).
- Enable module connected-mode for a given time period and then disable it for a time period enough long to properly mitigate temperature increase.

2.15 ESD guidelines

The sections 2.15.1 and 2.15.2 are related to EMC / ESD immunity. The modules are ESD sensitive devices. The ESD sensitivity for each pin (as Human Body Model according to JESD22-A114F) is specified in TOBY-L2 series Data Sheet [1] or MPC1-L2 series Data Sheet [2]. Special precautions are required when handling the pins; for ESD handling guidelines see section 3.2.

2.15.1 ESD immunity test overview

The immunity of devices integrating TOBY-L2 and MPC1-L2 series modules to Electro-Static Discharge (ESD) is part of the Electro-Magnetic Compatibility (EMC) conformity which is required for products bearing the CE marking, compliant with the R&TTE Directive (99/5/EC), the EMC Directive (89/336/EEC) and the Low Voltage Directive (73/23/EEC) issued by the Commission of the European Community.

Compliance with these directives implies conformity to the following European Norms for device ESD immunity: ESD testing standard CENELEC EN 61000-4-2 [22] and the radio equipment standards ETSI EN 301 489-1 [23], ETSI EN 301 489-7 [24], ETSI EN 301 489-24 [25], which requirements are summarized in Table 47.

The ESD immunity test is performed at the enclosure port, defined by ETSI EN 301 489-1 [23] as the physical boundary through which the electromagnetic field radiates. If the device implements an integral antenna, the enclosure port is seen as all insulating and conductive surfaces housing the device. If the device implements a removable antenna, the antenna port can be separated from the enclosure port. The antenna port includes the antenna element and its interconnecting cable surfaces.

The applicability of ESD immunity test to the whole device depends on the device classification as defined by ETSI EN 301 489-1 [23]. Applicability of ESD immunity test to the relative device ports or the relative interconnecting cables to auxiliary equipment, depends on device accessible interfaces and manufacturer requirements, as defined by ETSI EN 301 489-1 [23].

Contact discharges are performed at conductive surfaces, while air discharges are performed at insulating surfaces. Indirect contact discharges are performed on the measurement setup horizontal and vertical coupling planes as defined in CENELEC EN 61000-4-2 [22].



For the definition of integral antenna, removable antenna, antenna port and device classification see ETSI EN 301 489-1 [23]. For the contact / air discharges definitions see CENELEC EN 61000-4-2 [22].

Application	Category	Immunity Level
All exposed surfaces of the radio equipment and ancillary equipment in a representative configuration	Contact Discharge	4 kV
	Air Discharge	8 kV

Table 47: EMC / ESD immunity requirements as defined by CENELEC EN 61000-4-2 and ETSI EN 301 489-1, 301 489-7, 301 489-24

2.15.2 ESD immunity test of TOBY-L2 and MPC1-L2 series reference designs

Although EMC / ESD certification is required for customized devices integrating TOBY-L2 and MPC1-L2 series modules for R&TTED and European Conformance CE mark, EMC certification (including ESD immunity) has been successfully performed on TOBY-L2 and MPC1-L2 series modules reference design according to European Norms summarized in Table 47.

The EMC / ESD approved u-blox reference designs consist of a TOBY-L2 and MPC1-L2 series module installed onto a motherboard which provides supply interface, SIM card and communication port. External LTE/3G/2G antennas are connected to the provided connectors.

Since external antennas are used, the antenna port can be separated from the enclosure port. The reference design is not enclosed in a box so that the enclosure port is not identified with physical surfaces. Therefore, some test cases cannot be applied. Only the antenna port is identified as accessible for direct ESD exposure.

Table 48 reports the u-blox TOBY-L2 and MPC1-L2 series reference designs ESD immunity test results, according to test requirements stated in the CENELEC EN 61000-4-2 [22], ETSI EN 301 489-1 [23], ETSI EN 301 489-7 [24] and ETSI EN 301 489-24 [25].

Category	Application	Immunity Level	Remarks
Contact Discharge to coupling planes (indirect contact discharge)	Enclosure	+4 kV / -4 kV	
Contact Discharges to conducted surfaces (direct contact discharge)	Enclosure port	Not Applicable	Test not applicable to u-blox reference design because it does not provide enclosure surface. The test is applicable only to equipment providing conductive enclosure surface.
	Antenna ports	+4 kV / -4 kV	Test applicable to u-blox reference design because it provides antennas with conductive & insulating surfaces. The test is applicable only to equipment providing antennas with conductive surface.
Air Discharge at insulating surfaces	Enclosure port	Not Applicable	Test not applicable to the u-blox reference design because it does not provide an enclosure surface. The test is applicable only to equipment providing insulating enclosure surface.
	Antenna ports	+8 kV / -8 kV	Test applicable to u-blox reference design because it provides antennas with conductive & insulating surfaces. The test is applicable only to equipment providing antennas with insulating surface.

Table 48: Enclosure ESD immunity level of u-blox TOBY-L2 and MPC1-L2 series modules reference designs



TOBY-L2 and MPC1-L2 reference design implement all the ESD precautions described in section 2.15.3.

2.15.3 ESD application circuits

The application circuits described in this section are recommended and should be implemented in the device integrating TOBY-L2 and MPC1-L2 series modules, according to the application device classification (see ETSI EN 301 489-1 [23]), to satisfy the requirements for ESD immunity test summarized in Table 47.

Antenna interface

The **ANT1** and **ANT2** ports of TOBY-L2 and MPC1-L2 series modules provide ESD immunity up to ± 4 kV for direct Contact Discharge and up to ± 8 kV for Air Discharge: no further precaution to ESD immunity test is needed, as implemented in the EMC / ESD approved reference design of TOBY-L2 and MPC1-L2 series modules.

The antenna interface application circuit implemented in the EMC / ESD approved reference designs of TOBY-L2 and MPC1-L2 series modules is described in Figure 47 in case of antennas detection circuit not implemented, and is described in Figure 48 and Table 28 in case of antennas detection circuit implemented (section 2.4).

RESET_N and PERST# pin

The following precautions are suggested for the **RESET_N** and the **PERST#** line of TOBY-L2 and MPC1-L2 series modules, depending on the application board handling, to satisfy ESD immunity test requirements:

- It is recommended to keep the connection line to **RESET_N** and **PERST#** as short as possible

Maximum ESD sensitivity rating of the **RESET_N** and the **PERST#** pin is 1 kV (Human Body Model according to JESD22-A114). Higher protection level could be required if the **RESET_N** or **PERST#** pin is externally accessible on the application board. The following precautions are suggested to achieve higher protection level:

- A general purpose ESD protection device (e.g. EPCOS CA05P4S14THSG varistor array or EPCOS CT0402S14AHSG varistor) should be mounted on the **RESET_N** or **PERST#** line, close to accessible point

The **RESET_N** and **PERST#** application circuit implemented in the EMC / ESD approved reference designs of TOBY-L2 and MPC1-L2 series modules is described in Figure 42 and Table 23 (section 2.3.2).

SIM interface

The following precautions are suggested for TOBY-L2 and MPC1-L2 series modules SIM interface, depending on the application board handling, to satisfy ESD immunity test requirements:

- A bypass capacitor of about 22 pF to 47 pF (e.g. Murata GRM1555C1H470J) must be mounted on the lines connected to the SIM interface pins to assure SIM interface functionality when an electrostatic discharge is applied to the application board enclosure
- It is suggested to use as short as possible connection lines at SIM pins

Maximum ESD sensitivity rating of SIM interface pins is 1 kV (Human Body Model according to JESD22-A114). Higher protection level could be required if SIM interface pins are externally accessible on the application board. The following precautions are suggested to achieve higher protection level:

- A low capacitance (i.e. less than 10 pF) ESD protection device (e.g. Tyco Electronics PESD0402-140) should be mounted on each SIM interface line, close to accessible points (i.e. close to the SIM card holder)

The SIM interface application circuit implemented in the EMC / ESD approved reference designs of TOBY-L2 and MPC1-L2 series modules is described in Figure 49 and Table 29 (section 2.5).

Other pins and interfaces

All the module pins that are externally accessible on the device integrating TOBY-L2 and MPC1-L2 series module should be included in the ESD immunity test since they are considered to be a port as defined in ETSI EN 301 489-1 [23]. Depending on applicability, to satisfy ESD immunity test requirements according to ESD category level, all the module pins that are externally accessible should be protected up to ± 4 kV for direct Contact Discharge and up to ± 8 kV for Air Discharge applied to the enclosure surface.

The maximum ESD sensitivity rating of all the other pins of the module is 1 kV (Human Body Model according to JESD22-A114). Higher protection level could be required if the relative pin is externally accessible on the application board. The following precautions are suggested to achieve higher protection level:

- **USB interface:** a very low capacitance (i.e. less or equal to 1 pF) ESD protection device (e.g. Tyco Electronics PESD0402-140 ESD protection device) should be mounted on the **USB_D+** and **USB_D-** lines, close to the accessible points (i.e. close to the USB connector)
- **Other pins:** a general purpose ESD protection device (e.g. EPCOS CA05P4S14THSG varistor array or EPCOS CT0402S14AHSG varistor) should be mounted on the related line, close to accessible point

2.16 Schematic for TOBY-L2 and MPC1-L2 series module integration

2.16.1 Schematic for TOBY-L200-00S / TOBY-L210-00S

Figure 75 is an example of a schematic diagram where a TOBY-L200-00S / TOBY-L210-00S module is integrated into an application board, using all the available interfaces and functions of the module.

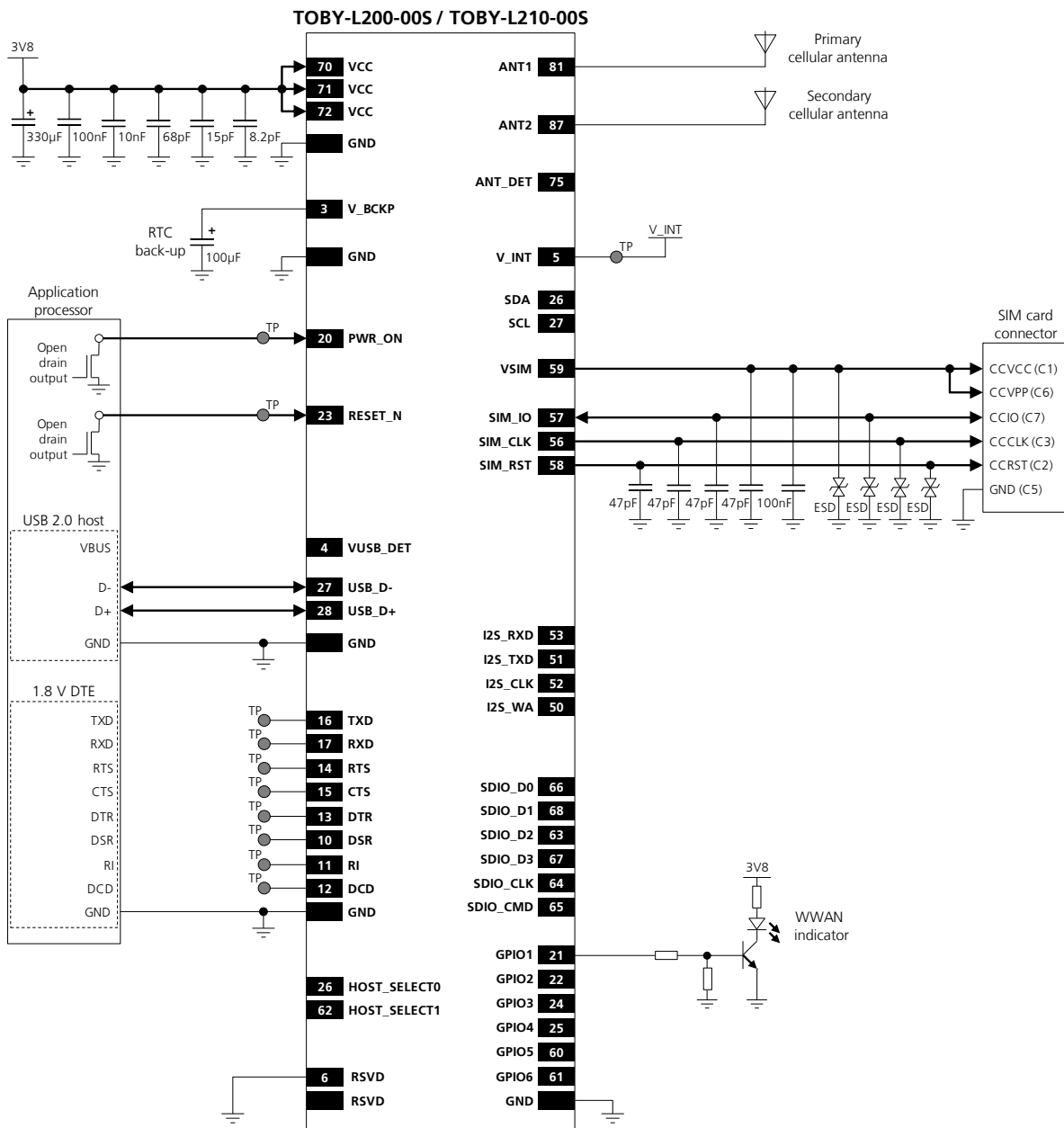

Figure 75: Example of schematic diagram to integrate a TOBY-L200-00S / TOBY-L210-00S in an application, using all interfaces

2.16.2 Schematic for TOBY-L201-01S / TOBY-L280-00S

Figure 76 is an example of a schematic diagram where a TOBY-L201-01S / TOBY-L280-00S module is integrated into an application board, using all the available interfaces and functions of the module.

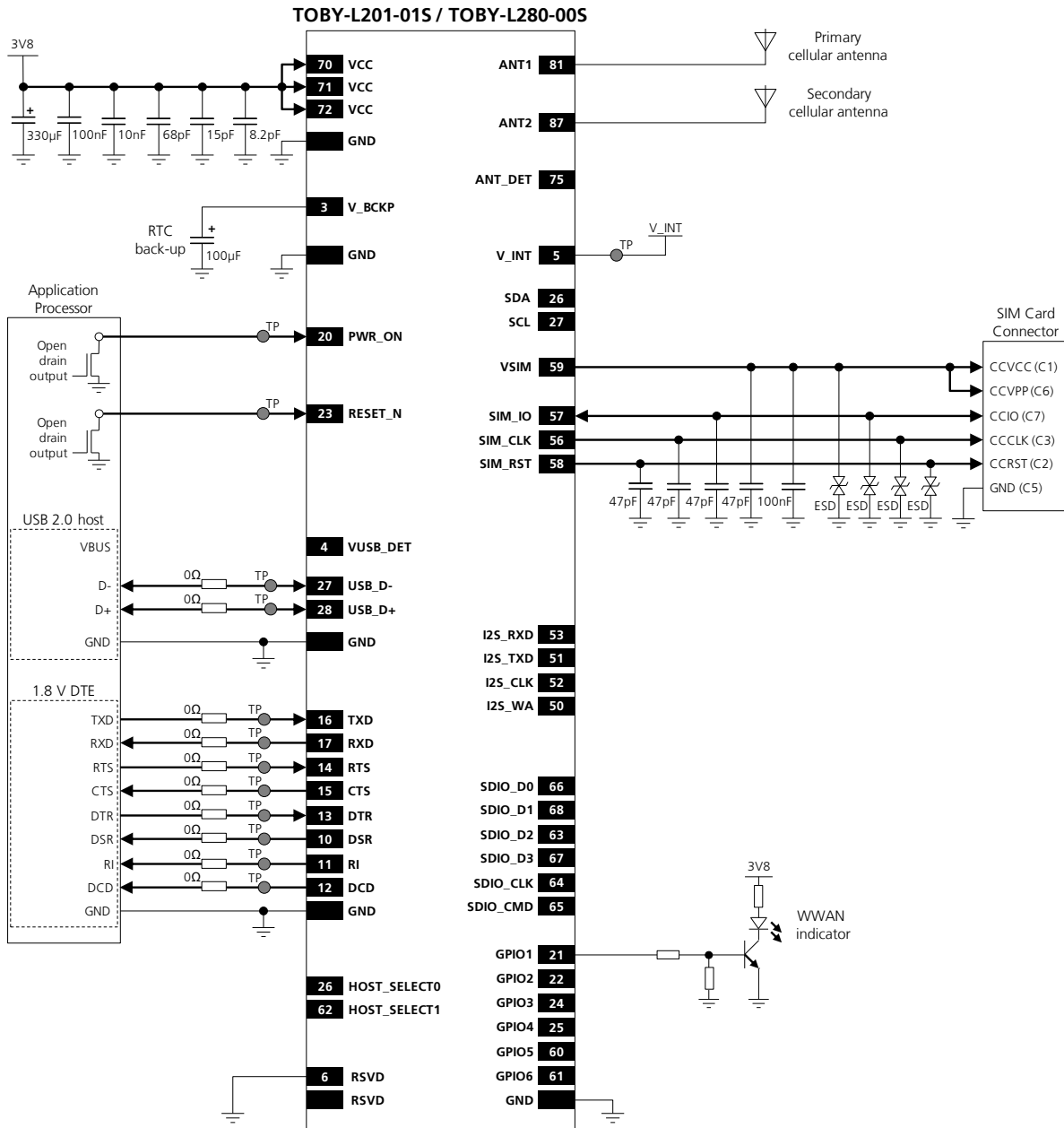

Figure 76: Example of schematic diagram to integrate a TOBY-L201-01S / TOBY-L280-00S in an application, using all interfaces

2.16.3 Schematic for TOBY-L200-50S / TOBY-L210-50S

Figure 77 is an example of a schematic diagram where a TOBY-L200-50S / TOBY-L210-50S module is integrated into an application board, using all the available interfaces and functions of the module.

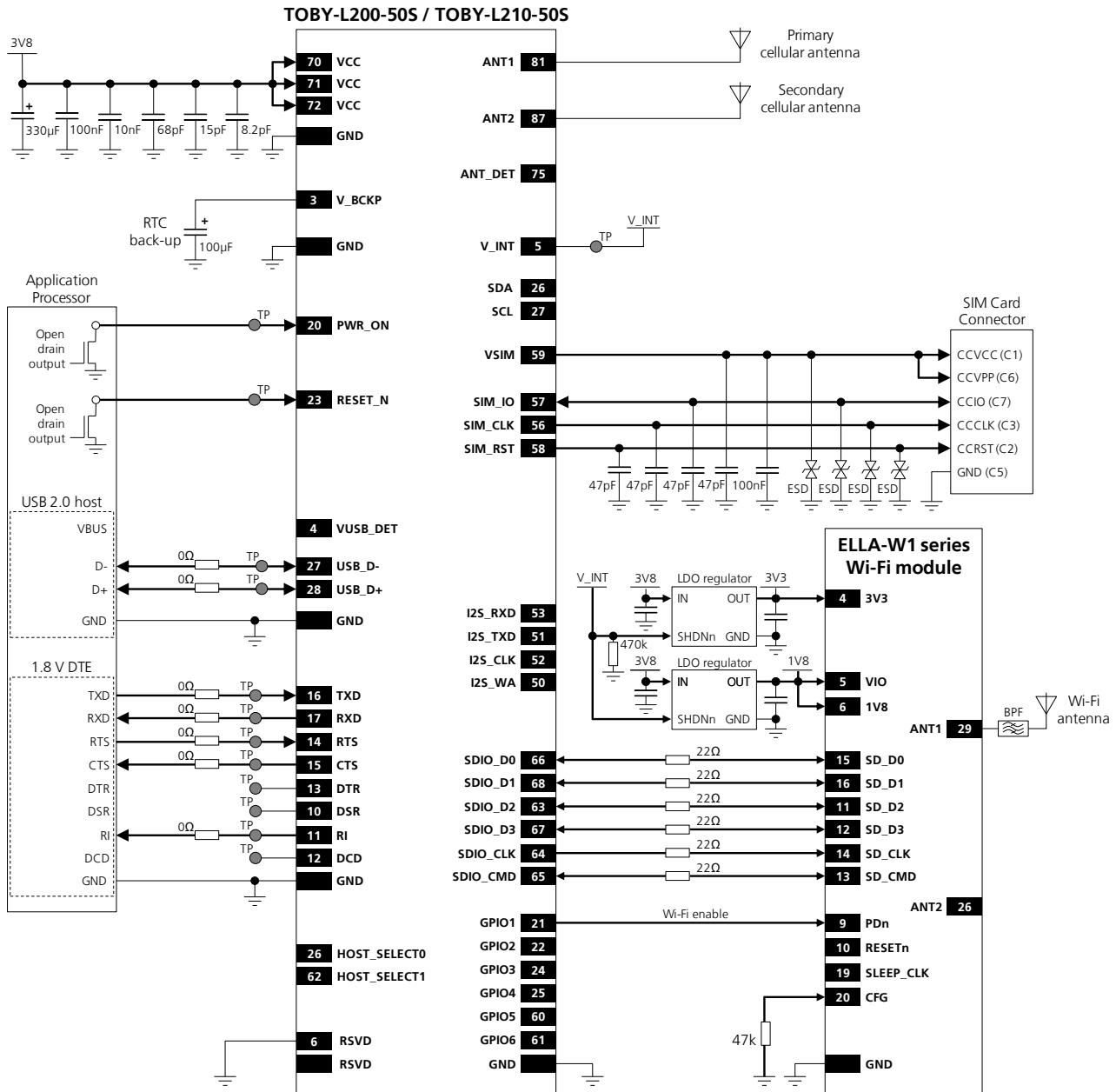

Figure 77: Example of schematic diagram to integrate a TOBY-L200-50S / TOBY-L210-50S in an application, using all interfaces

2.16.4 Schematic for MPC1-L2 series

Figure 78 is an example of a schematic diagram where a MPC1-L2 series module is integrated into an application board, using all the available interfaces and functions of the module.

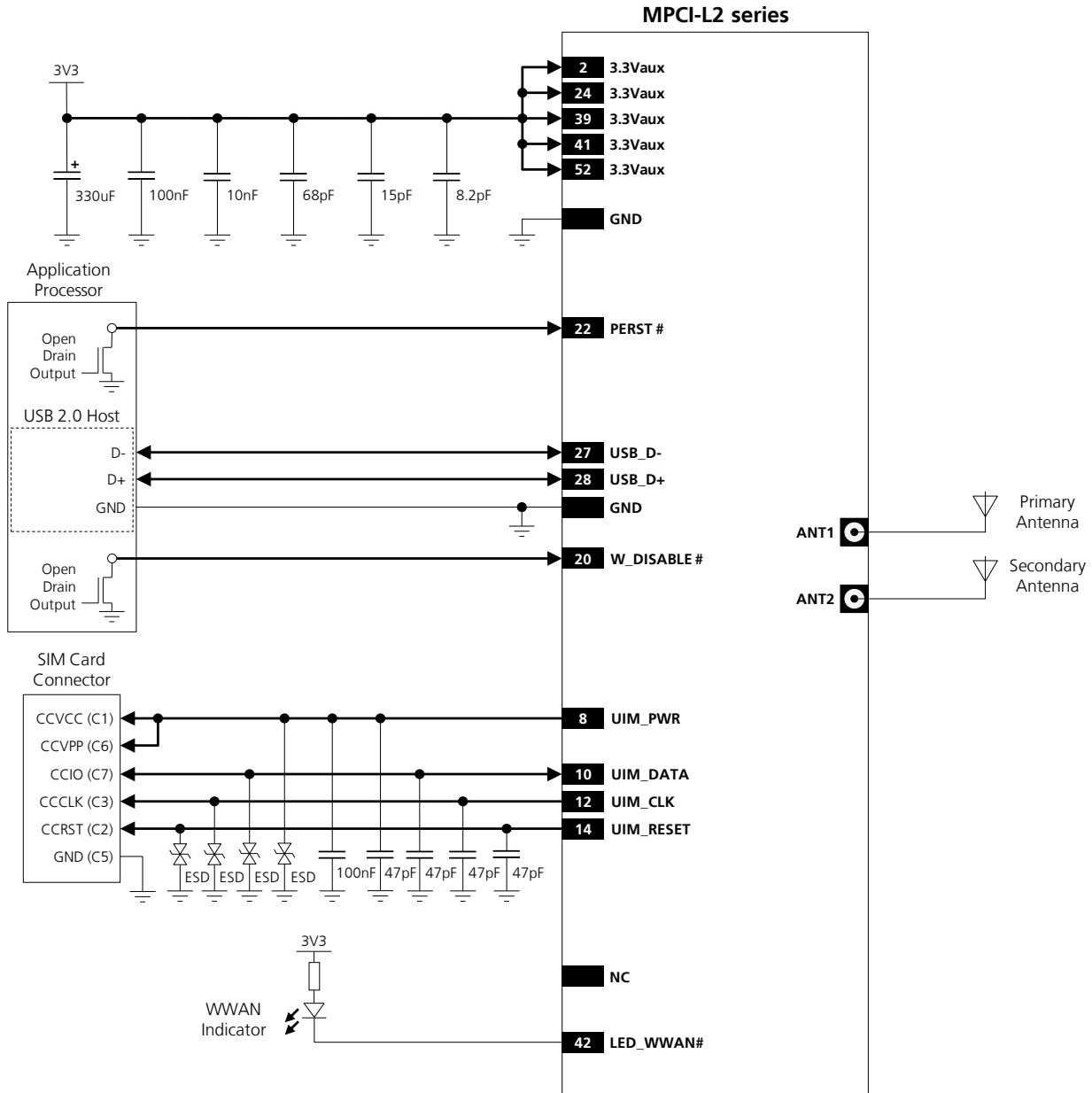

Figure 78: Example of schematic diagram to integrate a MPC1-L2 series module in an application board, using all the interfaces

2.17 Design-in checklist

This section provides a design-in checklist.

2.17.1 Schematic checklist

The following are the most important points for a simple schematic check:

- ✓ DC supply must provide a nominal voltage at **VCC / 3.3Vaux** pin within the operating range limits.
- ✓ DC supply must be capable of supporting both the highest peak and the highest averaged current consumption values in connected-mode, as specified in the TOBY-L2 series Data Sheet [1] or in the MPC1-L2 series Data Sheet [2].
- ✓ **VCC / 3.3Vaux** voltage supply should be clean, with very low ripple/noise: provide the suggested bypass capacitors, in particular if the application device integrates an internal antenna.
- ✓ Do not apply loads which might exceed the limit for maximum available current from **V_INT** supply.
- ✓ Check that voltage level of any connected pin does not exceed the relative operating range.
- ✓ Check **USB_D+ / USB_D-** signal lines as well as very low capacitance ESD protections if accessible.
- ✓ Capacitance and series resistance must be limited on each SIM signal to match the SIM specifications.
- ✓ Insert the suggested capacitors on each SIM signal and low capacitance ESD protections if accessible.
- ✓ Check UART signals direction, as the TOBY-L2 signal names follow the ITU-T V.24 Recommendation [7].
- ✓ Consider providing appropriate low value series damping resistors on SDIO lines to avoid reflections.
- ✓ Provide accessible test points directly connected to the following pins of the TOBY-L2 series modules: **V_INT**, **PWR_ON** and **RESET_N** for diagnostic purpose.
- ✓ Provide accessible test points directly connected to all the UART pins of the TOBY-L2 series modules (**TXD**, **RXD**, **RTS**, **CTS**, **DTR**, **DSR**, **DCD**, **RI**) for diagnostic purpose, in particular providing a 0 Ω series jumper on each line to detach each UART pin of the module from the DTE application processor.
- ✓ If the USB is not used, provide accessible test points directly connected to the **USB_D+** and **USB_D-** pins
- ✓ Provide proper precautions for EMC / ESD immunity as required on the application board.
- ✓ Do not apply voltage to any generic digital interface pin of TOBY-L2 series modules before the switch-on of the generic digital interface supply source (**V_INT**).
- ✓ All unused pins can be left unconnected except the **RSVD** pin number 6 of TOBY-L2 series modules, which must be connected to GND.

2.17.2 Layout checklist

The following are the most important points for a simple layout check:

- ☑ Check 50 Ω nominal characteristic impedance of the RF transmission line connected to the **ANT1** and the **ANT2** ports (antenna RF interfaces).
- ☑ Ensure no coupling occurs between the RF interface and noisy or sensitive signals (primarily USB signals, digital input/output signals, SIM signals, high-speed digital lines such as SDIO and other data lines).
- ☑ Optimize placement for minimum length of RF line.
- ☑ Check the footprint and paste mask designed for TOBY-L2 module as illustrated in section 2.12.
- ☑ **VCC / 3.3Vaux** line should be wide and as short as possible.
- ☑ Route **VCC / 3.3Vaux** supply line away from RF lines / parts and other sensitive analog lines / parts.
- ☑ The **VCC / 3.3Vaux** bypass capacitors in the picoFarad range should be placed as close as possible to the **VCC / 3.3Vaux** pins, in particular if the application device integrates an internal antenna.
- ☑ Ensure an optimal grounding connecting each **GND** pin with application board solid ground layer.
- ☑ Use as many vias as possible to connect the ground planes on multilayer application board, providing a dense line of vias at the edges of each ground area, in particular along RF and high speed lines.
- ☑ Keep routing short and minimize parasitic capacitance on the SIM lines to preserve signal integrity.
- ☑ **USB_D+ / USB_D-** traces should meet the characteristic impedance requirement (90 Ω differential and 30 Ω common mode) and should not be routed close to any RF line / part.
- ☑ Keep the SDIO traces short, avoid stubs, avoid coupling with any RF line / part and consider low value series damping resistors to avoid reflections and other losses in signal integrity.
- ☑ Ensure appropriate RF precautions for the Wi-Fi and Cellular technologies coexistence as described in section 2.6.4 and in the Wi-Fi / Cellular Integration Application Note [14].
- ☑ Ensure appropriate RF precautions for the GNSS and Cellular technologies coexistence as described in the GNSS Implementation Application Note [13].

2.17.3 Antenna checklist

- ☑ Antenna termination should provide 50 Ω characteristic impedance with V.S.W.R at least less than 3:1 (recommended 2:1) on operating bands in deployment geographical area.
- ☑ Follow the recommendations of the antenna producer for correct antenna installation and deployment (PCB layout and matching circuitry).
- ☑ Ensure compliance with any regulatory agency RF radiation requirement, as reported in section 4.2.2 for products marked with the FCC.
- ☑ Ensure high and similar efficiency for both the primary (**ANT1**) and the secondary (**ANT2**) antenna.
- ☑ Ensure high isolation between the primary (**ANT1**) and the secondary (**ANT2**) antenna.
- ☑ Ensure low Envelope Correlation Coefficient between the primary (**ANT1**) and the secondary (**ANT2**) antenna: the 3D antenna radiation patterns should have radiation lobes in different directions.
- ☑ Ensure high isolation between the cellular antennas and any other antenna or transmitter.

3 Handling and soldering



No natural rubbers, no hygroscopic materials or materials containing asbestos are employed.

3.1 Packaging, shipping, storage and moisture preconditioning

For information pertaining to TOBY-L2 series reels / tapes, MPC1-L2 series trays, Moisture Sensitivity levels (MSD), shipment and storage information, as well as drying for preconditioning, see the TOBY-L2 series Data Sheet [1], the MPC1-L2 series Data Sheet [2] and the u-blox Package Information Guide [31].

3.2 Handling

The TOBY-L2 and MPC1-L2 series modules are Electro-Static Discharge (ESD) sensitive devices.



Ensure ESD precautions are implemented during handling of the module.



Electrostatic discharge (ESD) is the sudden and momentary electric current that flows between two objects at different electrical potentials caused by direct contact or induced by an electrostatic field. The term is usually used in the electronics and other industries to describe momentary unwanted currents that may cause damage to electronic equipment.

The ESD sensitivity for each pin of TOBY-L2 and MPC1-L2 series modules (as Human Body Model according to JESD22-A114F) is specified in the TOBY-L2 series Data Sheet [1] or the MPC1-L2 series Data Sheet [2].

ESD prevention is based on establishing an Electrostatic Protective Area (EPA). The EPA can be a small working station or a large manufacturing area. The main principle of an EPA is that there are no highly charging materials near ESD sensitive electronics, all conductive materials are grounded, workers are grounded, and charge build-up on ESD sensitive electronics is prevented. International standards are used to define typical EPA and can be obtained for example from International Electrotechnical Commission (IEC) or American National Standards Institute (ANSI).

In addition to standard ESD safety practices, the following measures should be taken into account whenever handling the TOBY-L2 and MPC1-L2 series modules:

- Unless there is a galvanic coupling between the local GND (i.e. the work table) and the PCB GND, then the first point of contact when handling the PCB must always be between the local GND and PCB GND.
- Before mounting an antenna patch, connect ground of the device.
- When handling the module, do not come into contact with any charged capacitors and be careful when contacting materials that can develop charges (e.g. patch antenna, coax cable, soldering iron,...).
- To prevent electrostatic discharge through the RF pin, do not touch any exposed antenna area. If there is any risk that such exposed antenna area is touched in non ESD protected work area, implement proper ESD protection measures in the design.
- When soldering the module and patch antennas to the RF pin, make sure to use an ESD safe soldering iron.

For more robust designs, employ additional ESD protection measures on the application device integrating the TOBY-L2 and MPC1-L2 series modules, as described in section 2.15.3.

3.3 Soldering

3.3.1 Soldering paste

"No Clean" soldering paste is strongly recommended for TOBY-L2 series modules, as it does not require cleaning after the soldering process has taken place. The paste listed in the example below meets these criteria.

Soldering Paste: OM338 SAC405 / Nr.143714 (Cookson Electronics)
 Alloy specification: 95.5% Sn / 3.9% Ag / 0.6% Cu (95.5% Tin / 3.9% Silver / 0.6% Copper)
 95.5% Sn / 4.0% Ag / 0.5% Cu (95.5% Tin / 4.0% Silver / 0.5% Copper)

Melting Temperature: 217 °C

Stencil Thickness: 150 µm for base boards

The final choice of the soldering paste depends on the approved manufacturing procedures.

The paste-mask geometry for applying soldering paste should meet the recommendations in section 2.12.

 The quality of the solder joints on the connectors ("half vias") should meet the appropriate IPC specification.

3.3.2 Reflow soldering

A convection type-soldering oven is strongly recommended for TOBY-L2 series modules over the infrared type radiation oven. Convection heated ovens allow precise control of the temperature and all parts will be heated up evenly, regardless of material properties, thickness of components and surface color.

Consider the "IPC-7530 Guidelines for temperature profiling for mass soldering (reflow and wave) processes", published 2001.

Reflow profiles are to be selected according to the following recommendations.

 **Failure to observe these recommendations can result in severe damage to the device!**

Preheat phase

Initial heating of component leads and balls. Residual humidity will be dried out. Note that this preheat phase will not replace prior baking procedures.

- Temperature rise rate: max 3 °C/s. If the temperature rise is too rapid in the preheat phase it may cause excessive slumping.
- Time: 60 – 120 s. If the preheat is insufficient, rather large solder balls tend to be generated. Conversely, if performed excessively, fine balls and large balls will be generated in clusters.
- End Temperature: 150 - 200 °C. If the temperature is too low, non-melting tends to be caused in areas containing large heat capacity.

Heating/ reflow phase

The temperature rises above the liquidus temperature of 217 °C. Avoid a sudden rise in temperature as the slump of the paste could become worse.

- Limit time above 217 °C liquidus temperature: 40 - 60 s
- Peak reflow temperature: 245 °C

Cooling phase

A controlled cooling avoids negative metallurgical effects (solder becomes more brittle) of the solder and possible mechanical tensions in the products. Controlled cooling helps to achieve bright solder fillets with a good shape and low contact angle.

- Temperature fall rate: max 4 °C/s

To avoid falling off, modules should be placed on the topside of the motherboard during soldering.

The soldering temperature profile chosen at the factory depends on additional external factors like choice of soldering paste, size, thickness and properties of the base board, etc.

Exceeding the maximum soldering temperature and the maximum liquidus time limit in the recommended soldering profile may permanently damage the module.

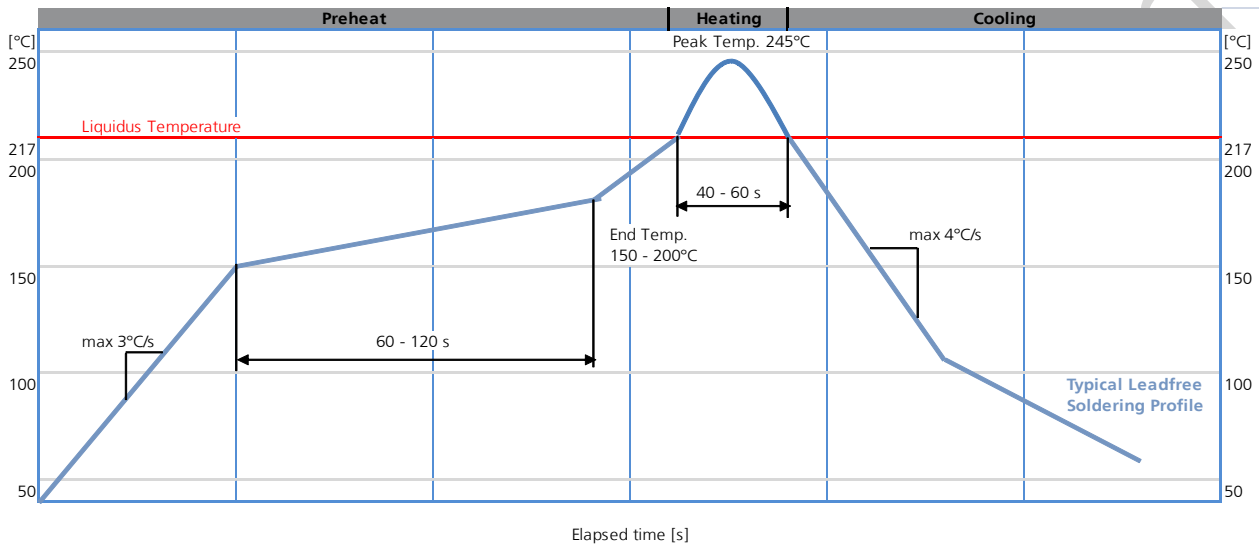

Figure 79: Recommended soldering profile

The modules must not be soldered with a damp heat process.

3.3.3 Optical inspection

After soldering the TOBY-L2 series modules, inspect the modules optically to verify that the module is properly aligned and centered.

3.3.4 Cleaning

Cleaning the modules is not recommended. Residues underneath the modules cannot be easily removed with a washing process.

- Cleaning with water will lead to capillary effects where water is absorbed in the gap between the baseboard and the module. The combination of residues of soldering flux and encapsulated water leads to short circuits or resistor-like interconnections between neighboring pads. Water will also damage the sticker and the ink-jet printed text.
- Cleaning with alcohol or other organic solvents can result in soldering flux residues flooding into the two housings, areas that are not accessible for post-wash inspections. The solvent will also damage the sticker and the ink-jet printed text.
- Ultrasonic cleaning will permanently damage the module, in particular the quartz oscillators.

For best results use a "no clean" soldering paste and eliminate the cleaning step after the soldering.

3.3.5 Repeated reflow soldering

Only a single reflow soldering process is encouraged for boards with a module populated on it.

3.3.6 Wave soldering

Boards with combined through-hole technology (THT) components and surface-mount technology (SMT) devices require wave soldering to solder the THT components. Only a single wave soldering process is encouraged for boards populated with the modules.

3.3.7 Hand soldering

Hand soldering is not recommended.

3.3.8 Rework

Rework is not recommended.



Never attempt a rework on the module itself, e.g. replacing individual components. Such actions immediately terminate the warranty.

3.3.9 Conformal coating

Certain applications employ a conformal coating of the PCB using HumiSeal® or other related coating products. These materials affect the HF properties of the cellular modules and it is important to prevent them from flowing into the module.

The RF shields do not provide 100% protection for the module from coating liquids with low viscosity, therefore care is required in applying the coating.



Conformal Coating of the module will void the warranty.

3.3.10 Casting

If casting is required, use viscose or another type of silicon pottant. The OEM is strongly advised to qualify such processes in combination with the cellular modules before implementing this in the production.



Casting will void the warranty.

3.3.11 Grounding metal covers

Attempts to improve grounding by soldering ground cables, wick or other forms of metal strips directly onto the EMI covers is done at the customer's own risk. The numerous ground pins should be sufficient to provide optimum immunity to interferences and noise.



u-blox gives no warranty for damages to the cellular modules caused by soldering metal cables or any other forms of metal strips directly onto the EMI covers.

3.3.12 Use of ultrasonic processes

The cellular modules contain components which are sensitive to Ultrasonic Waves. Use of any Ultrasonic Processes (cleaning, welding etc.) may cause damage to the module.



u-blox gives no warranty against damages to the cellular modules caused by any Ultrasonic Processes.

4 Approvals



For the complete list of all the certification schemes approvals of TOBY-L2 and MPC1-L2 series modules and the corresponding declarations of conformity, see the u-blox web-site (<http://www.u-blox.com/>).

4.1 Product certification approval overview

Product certification approval is the process of certifying that a product has passed all tests and criteria required by specifications, typically called “certification schemes” that can be divided into three distinct categories:

- Regulatory certification
 - Country specific approval required by local government in most regions and countries, such as:
 - CE (Conformité Européenne) marking for European Union
 - FCC (Federal Communications Commission) approval for United States
- Industry certification
 - Telecom industry specific approval verifying the interoperability between devices and networks:
 - GCF (Global Certification Forum), partnership between European device manufacturers and network operators to ensure and verify global interoperability between devices and networks
 - PTCRB (PCS Type Certification Review Board), created by United States network operators to ensure and verify interoperability between devices and North America networks
- Operator certification
 - Operator specific approval required by some mobile network operator, such as:
 - AT&T network operator in United States

Even if TOBY-L2 and MPC1-L2 series modules are approved under all major certification schemes, the application device that integrates TOBY-L2 and MPC1-L2 series modules must be approved under all the certification schemes required by the specific application device to be deployed in the market.

The required certification scheme approvals and relative testing specifications differ depending on the country or the region where the device that integrates TOBY-L2 and MPC1-L2 series modules must be deployed, on the relative vertical market of the device, on type, features and functionalities of the whole application device, and on the network operators where the device must operate.



The certification of the application device that integrates a TOBY-L2 module and the compliance of the application device with all the applicable certification schemes, directives and standards are the sole responsibility of the application device manufacturer.

TOBY-L2 and MPC1-L2 series modules are certified according to all capabilities and options stated in the Protocol Implementation Conformance Statement document (PICS) of the module. The PICS, according to the 3GPP TS 51.010-2 [26], 3GPP TS 34.121-2 [27], 3GPP TS 36.521-2 [28] and 3GPP TS 36.523-2 [29], is a statement of the implemented and supported capabilities and options of a device.



The PICS document of the application device integrating TOBY-L2 and MPC1-L2 series modules must be updated from the module PICS statement if any feature stated as supported by the module in its PICS document is not implemented or disabled in the application device. For more details regarding the AT commands settings that affect the PICS, see the u-blox AT Commands Manual [3].



Check the specific settings required for mobile network operators approvals as they may differ from the AT commands settings defined in the module as integrated in the application device.

4.2 US Federal Communications Commission notice

United States Federal Communications Commission (FCC) IDs:

- u-blox TOBY-L200 cellular modules: XPYTOBYL200
- u-blox TOBY-L201 cellular modules: XPYTOBYL201
- u-blox TOBY-L210 cellular modules: XPYTOBYL210
- u-blox TOBY-L280 cellular modules: XPYTOBYL280
- u-blox MPC1-L200 cellular modules: Contains FCC ID XPYTOBYL200
- u-blox MPC1-L210 cellular modules: Contains FCC ID XPYTOBYL210

4.2.1 Safety warnings review the structure

- Equipment for building-in. The requirements for fire enclosure must be evaluated in the end product
- The clearance and creepage current distances required by the end product must be withheld when the module is installed
- The cooling of the end product shall not negatively be influenced by the installation of the module
- Excessive sound pressure from earphones and headphones can cause hearing loss
- No natural rubbers, hygroscopic materials, or materials containing asbestos are employed

4.2.2 Declaration of Conformity

This device complies with Part 15 of the FCC rules. Operation is subject to the following two conditions:

- this device may not cause harmful interference
- this device must accept any interference received, including interference that may cause undesired operation

 **Radiofrequency radiation exposure Information: this equipment complies with radiation exposure limits prescribed for an uncontrolled environment for fixed and mobile use conditions. This equipment should be installed and operated with a minimum distance of 20 cm between the radiator and the body of the user or nearby persons. This transmitter must not be co-located or operating in conjunction with any other antenna or transmitter except as authorized in the certification of the product.**

 **The gain of the system antenna(s) used for the TOBY-L200, TOBY-L210, MPC1-L200, MPC1-L210 modules (i.e. the combined transmission line, connector, cable losses and radiating element gain) must not exceed 9.8 dBi (in 700 MHz, i.e. LTE FDD-17 band), 4.3 dBi (in 850 MHz, i.e. GSM 850 or UMTS FDD-5 or LTE FDD-5 band), 5.5 dBi (in 1700 MHz, i.e. AWS or UMTS FDD-4 or LTE FDD-4 band), 2.8 dBi (in 1900 MHz, i.e. GSM 1900 or UMTS FDD-2 or LTE FDD-2 band), 6.0 dBi (in 2500 MHz, i.e. LTE FDD-7 band) for mobile and fixed or mobile operating configurations.**

 **The gain of the system antenna(s) used for TOBY-L201 modules (i.e. the combined transmission line, connector, cable losses and radiating element gain) must not exceed 9.8 dBi (700 MHz, i.e. LTE FDD-17 band), 10.2 dBi (750 MHz, i.e. LTE FDD-13 band), 10.0 dBi (850 MHz, i.e. UMTS FDD-5 or LTE FDD-5 band), 6.8 dBi (1700 MHz, i.e. AWS or LTE FDD-4 band), 8.5 dBi (1900 MHz, i.e. UMTS FDD-2 or LTE FDD-2 band) for mobile and fixed or mobile operating configurations.**

 **The gain of the system antenna(s) used for TOBY-L280 modules (i.e. the combined transmission line, connector, cable losses and radiating element gain) must not exceed 4.3 dBi (850 MHz, i.e. GSM 850 or UMTS FDD-5 or LTE FDD-5 band), 3.4 dBi (1900 MHz, i.e. GSM 1900 or UMTS FDD-2 or LTE FDD-2 band), 10.8 dBi (2500 MHz, i.e. LTE FDD-7 band) for mobile and fixed or mobile operating configurations.**

4.2.3 Modifications

The FCC requires the user to be notified that any changes or modifications made to this device that are not expressly approved by u-blox could void the user's authority to operate the equipment.

 **Manufacturers of mobile or fixed devices incorporating the TOBY-L2 and MPC1-L2 series modules are authorized to use the FCC Grants of the TOBY-L2 series modules for their own final products according to the conditions referenced in the certificates.**

 **The FCC Label shall in the above case be visible from the outside, or the host device shall bear a second label stating:**

"Contains FCC ID: XPYTOBYL200" resp.

"Contains FCC ID: XPYTOBYL201" resp.

"Contains FCC ID: XPYTOBYL210" resp.

"Contains FCC ID: XPYTOBYL280" resp.

 **IMPORTANT: Manufacturers of portable applications incorporating the TOBY-L2 and MPC1-L2 series modules are required to have their final product certified and apply for their own FCC Grant related to the specific portable device. This is mandatory to meet the SAR requirements for portable devices.**

Changes or modifications not expressly approved by the party responsible for compliance could void the user's authority to operate the equipment.

 **Additional Note: as per 47CFR15.105 this equipment has been tested and found to comply with the limits for a Class B digital device, pursuant to part 15 of the FCC Rules. These limits are designed to provide reasonable protection against harmful interference in a residential installation. This equipment generates, uses and can radiate radio frequency energy and, if not installed and used in accordance with the instructions, may cause harmful interference to radio communications. However, there is no guarantee that interference will not occur in a particular installation. If this equipment does cause harmful interference to radio or television reception, which can be determined by turning the equipment off and on, the user is encouraged to try to correct the interference by one or more of the following measures:**





- Reorient or relocate the receiving antenna
- Increase the separation between the equipment and receiver
- Connect the equipment into an outlet on a circuit different from that to which the receiver is connected
- Consult the dealer or an experienced radio/TV technician for help

4.3 Industry Canada notice

Industry Canada (IC) Certification Numbers:



- u-blox TOBY-L200 cellular modules: 8595A-TOBYL200
- u-blox TOBY-L201 cellular modules: 8595A-TOBYL201
- u-blox TOBY-L210 cellular modules: 8595A-TOBYL210
- u-blox TOBY-L280 cellular modules: 8595A-TOBYL280
- u-blox MPC1-L200 cellular modules: Contains IC 8595A-TOBYL200
- u-blox MPC1-L210 cellular modules: Contains IC 8595A-TOBYL210

4.3.1 Declaration of Conformity

- 
Radiofrequency radiation exposure Information: this equipment complies with radiation exposure limits prescribed for an uncontrolled environment for fixed and mobile use conditions. This equipment should be installed and operated with a minimum distance of 20 cm between the radiator and the body of the user or nearby persons. This transmitter must not be co-located or operating in conjunction with any other antenna or transmitter except as authorized in the certification of the product.
- 
 The gain of the system antenna(s) used for the TOBY-L200, TOBY-L210, MPC1-L200, MPC1-L210 modules (i.e. the combined transmission line, connector, cable losses and radiating element gain) must not exceed 9.8 dBi (700 MHz, i.e. LTE FDD-17 band), 4.3 dBi (850 MHz, i.e. GSM 850 or UMTS FDD-5 or LTE FDD-5 band), 5.5 dBi (1700 MHz, i.e. AWS or UMTS FDD-4 or LTE FDD-4 band), 2.8 dBi (1900 MHz, i.e. GSM 1900 or UMTS FDD-2 or LTE FDD-2 band), 6.0 dBi (2500 MHz, i.e. LTE FDD-7 band) for mobile and fixed or mobile operating configurations.
- 
 The gain of the system antenna(s) used for TOBY-L201 modules (i.e. the combined transmission line, connector, cable losses and radiating element gain) must not exceed 6.7 dBi (700 MHz, i.e. LTE FDD-17 band), 6.9 dBi (750 MHz, i.e. LTE FDD-13 band), 6.7 dBi (850 MHz, i.e. UMTS FDD-5 or LTE FDD-5 band), 6.8 dBi (1700 MHz, i.e. AWS or LTE FDD-4 band), 8.5 dBi (1900 MHz, i.e. UMTS FDD-2 or LTE FDD-2 band) for mobile and fixed or mobile operating configurations.
- 
 .

4.3.2 Modifications

The IC requires the user to be notified that any changes or modifications made to this device that are not expressly approved by u-blox could void the user's authority to operate the equipment.

- 
Manufacturers of mobile or fixed devices incorporating the TOBY-L2 and MPC1-L2 series modules are authorized to use the Industry Canada Certificates of the TOBY-L2 series modules for their own final products according to the conditions referenced in the certificates.
- 
The IC Label shall in the above case be visible from the outside, or the host device shall bear a second label stating:
 - "Contains IC: 8595A-TOBYL200" resp.
 - "Contains IC: 8595A-TOBYL201" resp.
 - "Contains IC: 8595A-TOBYL210" resp.
 - "Contains IC: 8595A-TOBYL280" resp.

- 
Canada, Industry Canada (IC) Notices
This Class B digital apparatus complies with Canadian CAN ICES-3(B) / NMB-3(B) and RSS-210.
Operation is subject to the following two conditions:
 - this device may not cause interference
 - this device must accept any interference, including interference that may cause undesired operation of the device

Radio Frequency (RF) Exposure Information

The radiated output power of the u-blox Cellular Module is below the Industry Canada (IC) radio frequency exposure limits. The u-blox Cellular Module should be used in such a manner such that the potential for human contact during normal operation is minimized.

This device has been evaluated and shown compliant with the IC RF Exposure limits under mobile exposure conditions (antennas are greater than 20 cm from a person's body).

This device has been certified for use in Canada. Status of the listing in the Industry Canada's REL (Radio Equipment List) can be found at the following web address:

<http://www.ic.gc.ca/app/sitt/reltel/srch/nwRdSrch.do?lang=eng>

Additional Canadian information on RF exposure also can be found at the following web address: <http://www.ic.gc.ca/eic/site/smt-gst.nsf/eng/sf08792.html>

 **IMPORTANT:** Manufacturers of portable applications incorporating the TOBY-L2 and MPC1-L2 series modules are required to have their final product certified and apply for their own Industry Canada Certificate related to the specific portable device. This is mandatory to meet the SAR requirements for portable devices.

Changes or modifications not expressly approved by the party responsible for compliance could void the user's authority to operate the equipment.

 **Canada, avis d'Industrie Canada (IC)**
Cet appareil numérique de classe B est conforme aux normes canadiennes CAN ICES-3B) / NMB-3(B) et CNR-210.

Son fonctionnement est soumis aux deux conditions suivantes:

- cet appareil ne doit pas causer d'interférence
- cet appareil doit accepter toute interférence, notamment les interférences qui peuvent affecter son fonctionnement

Informations concernant l'exposition aux fréquences radio (RF)

La puissance de sortie émise par l'appareil de sans fil u-blox Cellular Module est inférieure à la limite d'exposition aux fréquences radio d'Industrie Canada (IC). Utilisez l'appareil de sans fil u-blox Cellular Module de façon à minimiser les contacts humains lors du fonctionnement normal.

Ce périphérique a été évalué et démontré conforme aux limites d'exposition aux fréquences radio (RF) d'IC lorsqu'il est installé dans des produits hôtes particuliers qui fonctionnent dans des conditions d'exposition à des appareils mobiles (les antennes se situent à plus de 20 centimètres du corps d'une personne).

Ce périphérique est homologué pour l'utilisation au Canada. Pour consulter l'entrée correspondant à l'appareil dans la liste d'équipement radio (REL - Radio Equipment List) d'Industrie Canada rendez-vous sur:

<http://www.ic.gc.ca/app/sitt/reltel/srch/nwRdSrch.do?lang=fra>

Pour des informations supplémentaires concernant l'exposition aux RF au Canada rendez-vous sur: <http://www.ic.gc.ca/eic/site/smt-gst.nsf/fra/sf08792.html>

 **IMPORTANT:** les fabricants d'applications portables contenant les modules TOBY-L2 and MPC1-L2 series doivent faire certifier leur produit final et déposer directement leur candidature pour une certification FCC ainsi que pour un certificat Industrie Canada délivré par l'organisme chargé de ce type d'appareil portable. Ceci est obligatoire afin d'être en accord avec les exigences SAR pour les appareils portables.

Tout changement ou modification non expressément approuvé par la partie responsable de la certification peut annuler le droit d'utiliser l'équipement.

4.4 Anatel certification

TOBY-L200-00S and MPC1-L200-00S modules are certified by the Brazilian Agency of Telecommunications (Agência Nacional de Telecomunicações in Portuguese) (Anatel).

Anatel IDs for the TOBY-L200-00S modules:

- EAN barcode: (01)07898941575236
- Homologation number 0806-15-5903

Anatel IDs for the MPC1-L200-00S modules:

- EAN barcode: (01)07898941575243
- Homologation number 3420-13-5903

4.5 R&TTED and European Conformance CE mark

The modules have been evaluated against the essential requirements of the 1999/5/EC Directive.

In order to satisfy the essential requirements of the 1999/5/EC Directive, the modules are compliant with the following standards:

- Radio Frequency spectrum use (R&TTE art. 3.2):
 - EN 301 511 V9.0.2
 - EN 301 908-1 V6.2.1
 - EN 301 908-2 V6.2.1
 - EN 301 908-13 (V6.2.1)
- Electromagnetic Compatibility (R&TTE art. 3.1b):
 - EN 301 489-1 V1.9.2
 - EN 301 489-7 V1.3.1
 - EN 301 489-24 V1.5.1
- Health and Safety (R&TTE art. 3.1a)
 - EN 60950-1:2006 + A11:2009 + A1:2010 + A12:2011 + A2:2013
 - EN 62311:2008

 **Radiofrequency radiation exposure Information: this equipment complies with radiation exposure limits prescribed for an uncontrolled environment for fixed and mobile use conditions. This equipment should be installed and operated with a minimum distance of 20 cm between the radiator and the body of the user or nearby persons. This transmitter must not be co-located or operating in conjunction with any other antenna or transmitter except as authorized in the certification of the product.**

The conformity assessment procedure for the modules, referred to in Article 10 and detailed in Annex IV of Directive 1999/5/EC, has been followed with the involvement of the following Notified Body number: 1588

Thus, the following marking is included in the product:

CE 1588

5 Product testing

5.1 u-blox in-series production test

u-blox focuses on high quality for its products. All units produced are fully tested automatically in production line. Stringent quality control process has been implemented in the production line. Defective units are analyzed in detail to improve the production quality.

This is achieved with automatic test equipment (ATE) in production line, which logs all production and measurement data. A detailed test report for each unit can be generated from the system. Figure 80 illustrates typical automatic test equipment (ATE) in a production line.

The following typical tests are among the production tests.

- Digital self-test (firmware download, Flash firmware verification, IMEI programming)
- Measurement of voltages and currents
- Adjustment of ADC measurement interfaces
- Functional tests (USB interface communication, SIM card communication)
- Digital tests (GPIOs and other interfaces)
- Measurement and calibration of RF characteristics in all supported bands (such as receiver S/N verification, frequency tuning of reference clock, calibration of transmitter and receiver power levels, etc.)
- Verification of RF characteristics after calibration (i.e. modulation accuracy, power levels, spectrum, etc. are checked to ensure they are all within tolerances when calibration parameters are applied)

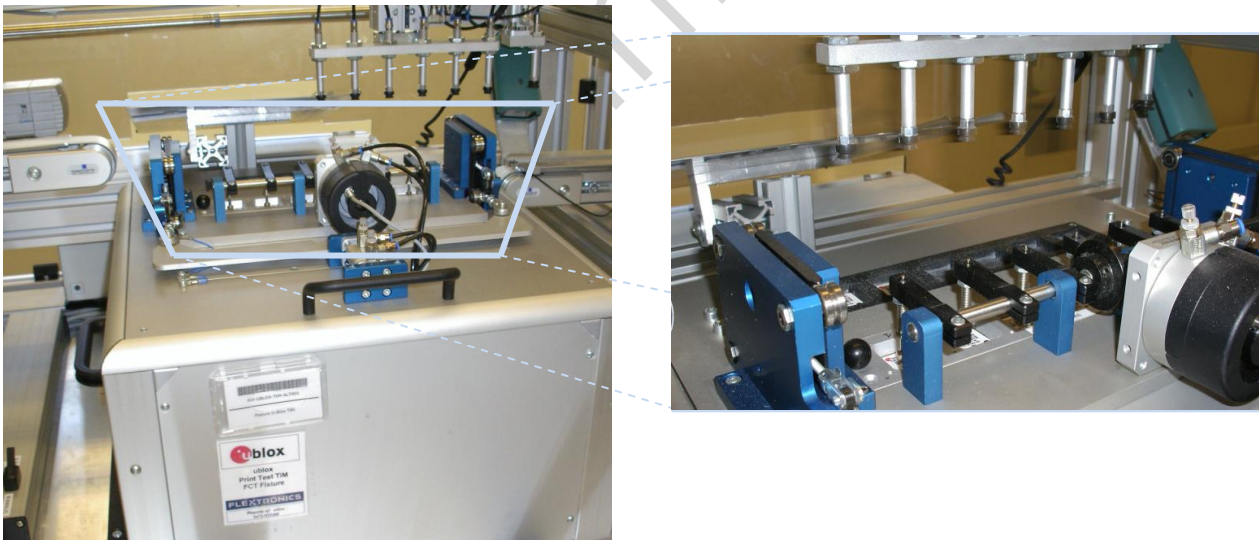

Figure 80: Automatic test equipment for module tests

5.2 Test parameters for OEM manufacturer

Because of the testing done by u-blox (with 100% coverage), an OEM manufacturer does not need to repeat firmware tests or measurements of the module RF performance or tests over analog and digital interfaces in their production test.

However, an OEM manufacturer should focus on:

- Module assembly on the device; it should be verified that:
 - Soldering and handling process did not damage the module components
 - All module pins are well soldered on device board
 - There are no short circuits between pins
- Component assembly on the device; it should be verified that:
 - Communication with host controller can be established
 - The interfaces between module and device are working
 - Overall RF performance test of the device including antenna

Dedicated tests can be implemented to check the device. For example, the measurement of module current consumption when set in a specified status can detect a short circuit if compared with a “Golden Device” result.

In addition, module AT commands can be used to perform functional tests (communication with host controller, check SIM interface, GPIOs, etc.) and to perform RF performance tests: see the following two sections for details.

5.2.1 “Go/No go” tests for integrated devices

A “Go/No go” test is typically to compare the signal quality with a “Golden Device” in a location with excellent network coverage and known signal quality. This test should be performed after data connection has been established. AT+CSQ is the typical AT command used to check signal quality in term of RSSI. See the u-blox AT Commands Manual [3] for detail usage of the AT command.



These kinds of test may be useful as a “go/no go” test but not for RF performance measurements.

This test is suitable to check the functionality of communication with host controller, SIM card as well as power supply. It is also a means to verify if components at antenna interface are well soldered.

5.2.2 RF functional tests

The overall RF functional test of the device including the antenna can be performed with basic instruments such as a spectrum analyzer (or an RF power meter) and a signal generator with the assistance of AT+UTEST command over AT command user interface.

The AT+UTEST command provides a simple interface to set the module to Rx or Tx test modes ignoring the LTE/3G/2G signaling protocol. The command can set the module into:

- transmitting mode in a specified channel and power level in all supported modulation schemes and bands
- receiving mode in a specified channel to returns the measured power level in all supported bands



See the u-blox AT Commands Manual [3] and the End user test Application Note [26], for the AT+UTEST command syntax description and detail guide of usage.

This feature allows the measurement of the transmitter and receiver power levels to check component assembly related to the module antenna interface and to check other device interfaces from which depends the RF performance.

- ⚠ **To avoid module damage during transmitter test, a proper antenna according to module specifications or a 50 Ω termination must be connected to ANT1 port.**
- ⚠ **To avoid module damage during receiver test the maximum power level received at ANT1 and ANT2 ports must meet module specifications.**

👉 The AT+UATEST command sets the module to emit RF power ignoring LTE/3G/2G signaling protocol. This emission can generate interference that can be prohibited by law in some countries. The use of this feature is intended for testing purpose in controlled environments by qualified user and must not be used during the normal module operation. Follow instructions suggested in u-blox documentation. u-blox assumes no responsibilities for the inappropriate use of this feature.

Figure 81 illustrates a typical test setup for such RF functional test.

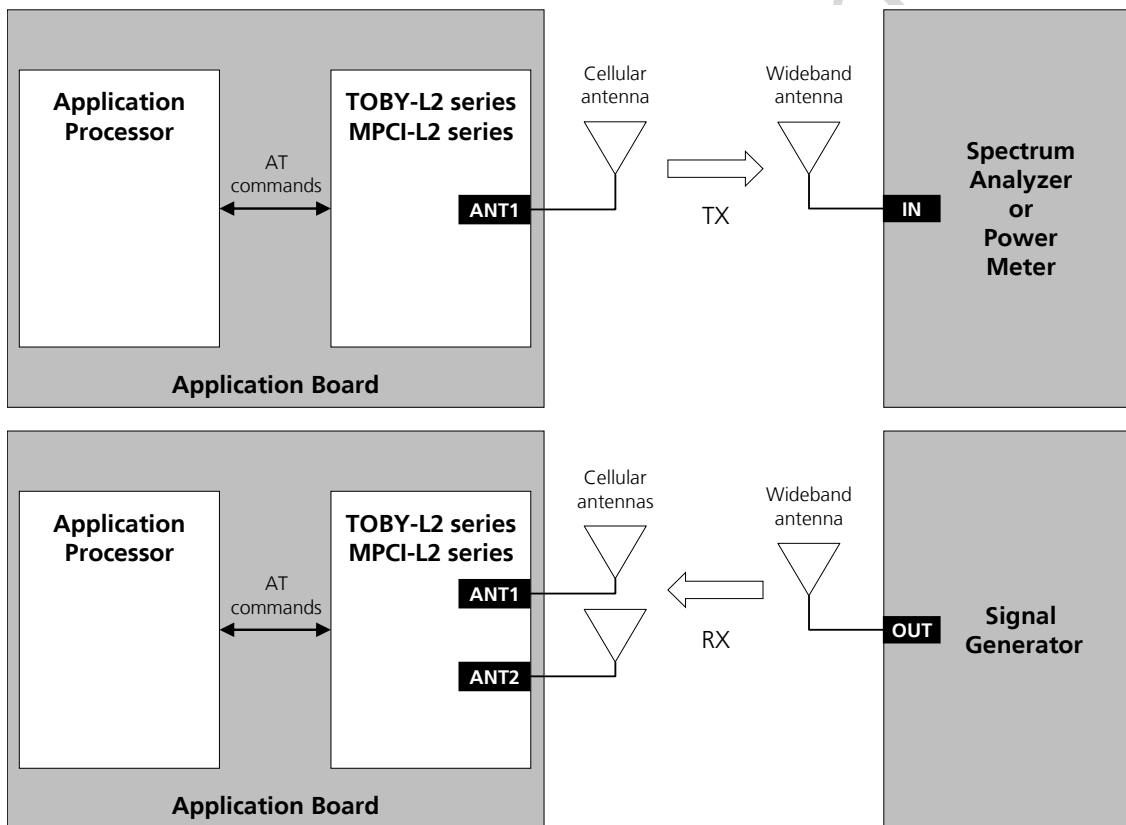

Figure 81: Setup with spectrum analyzer or power meter and signal generator for radiated measurements

Appendix

A Glossary

3GPP	3rd Generation Partnership Project
8-PSK	8 Phase-Shift Keying modulation
16QAM	16-state Quadrature Amplitude Modulation
64QAM	64-state Quadrature Amplitude Modulation
ACM	Abstract Control Model
ADC	Analog to Digital Converter
AP	Application Processor
ASIC	Application-Specific Integrated Circuit
AT	AT Command Interpreter Software Subsystem, or attention
BAW	Bulk Acoustic Wave
CSFB	Circuit Switched Fall-Back
DC	Direct Current
DCE	Data Communication Equipment
DDC	Display Data Channel interface
DL	Down-Link (Reception)
DRX	Discontinuous Reception
DSP	Digital Signal Processing
DTE	Data Terminal Equipment
ECM	Ethernet networking Control Model
EDGE	Enhanced Data rates for GSM Evolution
EMC	Electro-Magnetic Compatibility
EMI	Electro-Magnetic Interference
ESD	Electro-Static Discharge
ESR	Equivalent Series Resistance
E-UTRA	Evolved Universal Terrestrial Radio Access
FDD	Frequency Division Duplex
FEM	Front End Module
FOAT	Firmware Over AT commands
FOTA	Firmware Over The Air
FTP	File Transfer Protocol
FW	Firmware
GND	Ground
GNSS	Global Navigation Satellite System
GPIO	General Purpose Input Output
GPRS	General Packet Radio Service
GPS	Global Positioning System
HBM	Human Body Model
HSIC	High Speed Inter Chip
HSDPA	High Speed Downlink Packet Access
HSUPA	High Speed Uplink Packet Access
HTTP	HyperText Transfer Protocol
HW	Hardware
I/Q	In phase and Quadrature
I ² C	Inter-Integrated Circuit interface
I ² S	Inter IC Sound interface

IP	Internet Protocol
LDO	Low-Dropout
LGA	Land Grid Array
LNA	Low Noise Amplifier
LPDDR	Low Power Double Data Rate synchronous dynamic RAM memory
LTE	Long Term Evolution
M2M	Machine-to-Machine
MBIM	Mobile Broadband Interface Model
MIMO	Multi-Input Multi-Output
N/A	Not Applicable
N.A.	Not Available
NCM	Network Control Model
OTA	Over The Air
PA	Power Amplifier
PCM	Pulse Code Modulation
PCN / IN	Product Change Notification / Information Note
PCS	Personal Communications Service
PFM	Pulse Frequency Modulation
PMU	Power Management Unit
PWM	Pulse Width Modulation
QPSK	Quadrature Phase Shift Keying
RF	Radio Frequency
RMII	Reduced Media Independent Interface
RNDIS	Remote Network Driver Interface Specification
RSE	Radiated Spurious Emission
RTC	Real Time Clock
SAW	Surface Acoustic Wave
SDIO	Secure Digital Input Output
SIM	Subscriber Identification Module
SMS	Short Message Service
SRF	Self Resonant Frequency
SSL	Secure Socket Layer
TBD	To Be Defined
TCP	Transmission Control Protocol
TDD	Time Division Duplex
TDMA	Time Division Multiple Access
TIS	Total Isotropic Sensitivity
TP	Test-Point
TRP	Total Radiated Power
UART	Universal Asynchronous Receiver-Transmitter
UDP	User Datagram Protocol
UICC	Universal Integrated Circuit Card
UL	Up-Link (Transmission)
UMTS	Universal Mobile Telecommunications System
USB	Universal Serial Bus
VCO	Voltage Controlled Oscillator
VoLTE	Voice over LTE
VSWR	Voltage Standing Wave Ratio
Wi-Fi	Wireless Local Area Network (IEEE 802.11 short range radio technology)
WLAN	Wireless Local Area Network (IEEE 802.11 short range radio technology)
WWAN	Wireless Wide Area Network (GSM / UMTS / LTE cellular radio technology)

B Migration between TOBY-L1 and TOBY-L2

B.1 Overview

TOBY-L1 and TOBY-L2 series cellular modules have exactly the same TOBY form factor (35.6 x 24.8 mm LGA) with exactly the same 152-pin layout as described in Figure 82, so that the modules can be alternatively mounted on a single application board using exactly the same copper mask, solder mask and paste mask.

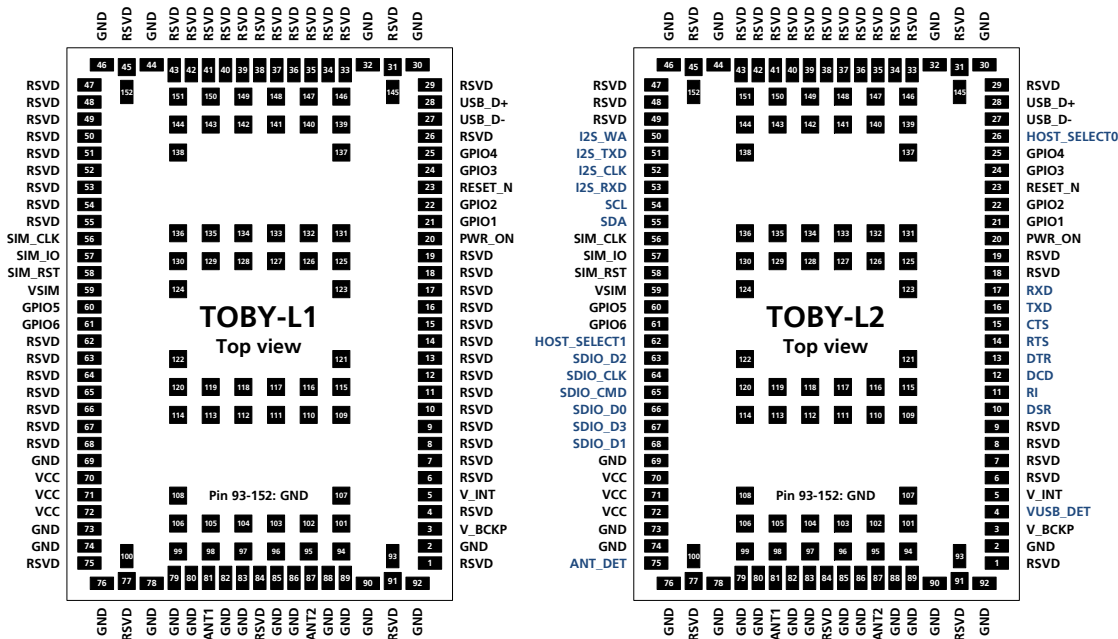

Figure 82: TOBY-L1 and TOBY-L2 series modules pad layout and pin assignment

TOBY modules are also form-factor compatible with the u-blox LISA and SARA cellular module families: although TOBY modules, LISA modules (33.2 x 22.4 mm, 76-pin LCC) and SARA modules (26.0 x 16.0 mm, 96-pin LGA) each have different form factors, the footprints for the TOBY, LISA and SARA modules have been developed to ensure layout compatibility.

With the u-blox “nested design” solution, any TOBY, LISA or SARA module can be alternatively mounted on the same space of a single “nested” application board as described in Figure 83. Guidelines in order to implement a nested application board, description of the u-blox reference design as nested application board and comparison between TOBY, LISA and SARA modules are provided in the Nested Design Application Note [32].

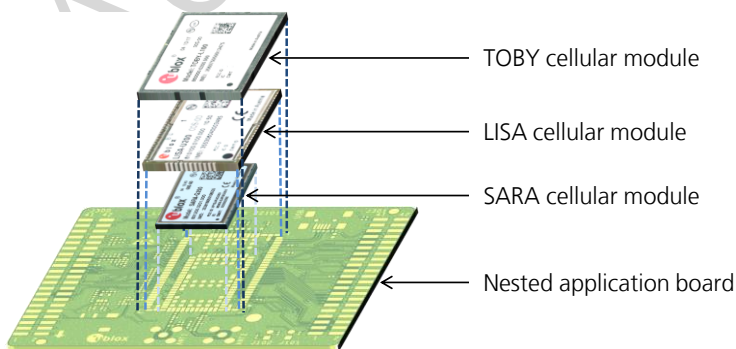

Figure 83: TOBY, LISA, SARA modules' layout compatibility: the nested design accommodates all modules on the same footprint

Table 49 summarizes the interfaces provided: TOBY-L2 series modules make available additional interfaces over pins remarked as reserved on TOBY-L1 series modules (highlighted in blue in Figure 82).

Module	Radio Access Technology					Power	System	SIM	Serial	Audio	GPIO																					
	LTE category	LTE bands	HSDPA category	HSUPA category	3G bands	GPRS/EDGE class	2G bands	MIMO 2x2 / Rx diversity	Antenna Detection	VCC module supply in	V_BACKP	V_INT 1.8 V supply out	PWR_ON	RESET_N	Host select	SIM 1.8 V / 3.0 V	SIM detection	UART 1.8 V	USB 2.0 High-Speed	SDIO 1.8 V	DCC (f°C) 1.8 V	Analog audio	Digital audio	GPIOs 1.8 V	Network indication	GNSS supply enable	GNSS Tx data ready	GNSS RTC sharing	Clock output	Wi-Fi control	Antenna tuning	
TOBY-L100	3	4,13						•	•	•	•	•	•	•	•	•	•	•	•	•	•	•		F	•							
TOBY-L200	4	2,4,5,7,17	24	6	1,2,4,5,8	12	Quad	•	F	•	•	•	•	•	F	•	F	○	•	○	F		F	F	□	F	F	F	F	F	○	F
TOBY-L201	4	2,4,5,13,17	24	6	2,5			•	F	•	•	•	•	•	F	•	F	•	•	F	F		F	F	•	F	F	F	F	F	F	F
TOBY-L210	4	1,3,5,7,8,20	24	6	1,2,5,8	12	Quad	•	F	•	•	•	•	•	F	•	F	○	•	○	F		F	F	□	F	F	F	F	F	○	F
TOBY-L280	4	1,3,5,7,8,28	24	6	1,2,5,8	12	Quad	•	F	•	•	•	•	•	F	•	F	•	•	F	F		F	F	•	F	F	F	F	F	F	F

• = supported by all product versions □ = supported by all product versions except product version "50"
 ○ = supported by product version "50" and future product versions F = supported by future product versions

Table 49: Summary of TOBY-L1 series and TOBY-L2 series modules interfaces

Figure 84 summarizes the LTE, 3G and 2G operating frequency bands of TOBY-L1 and TOBY-L2 series modules.

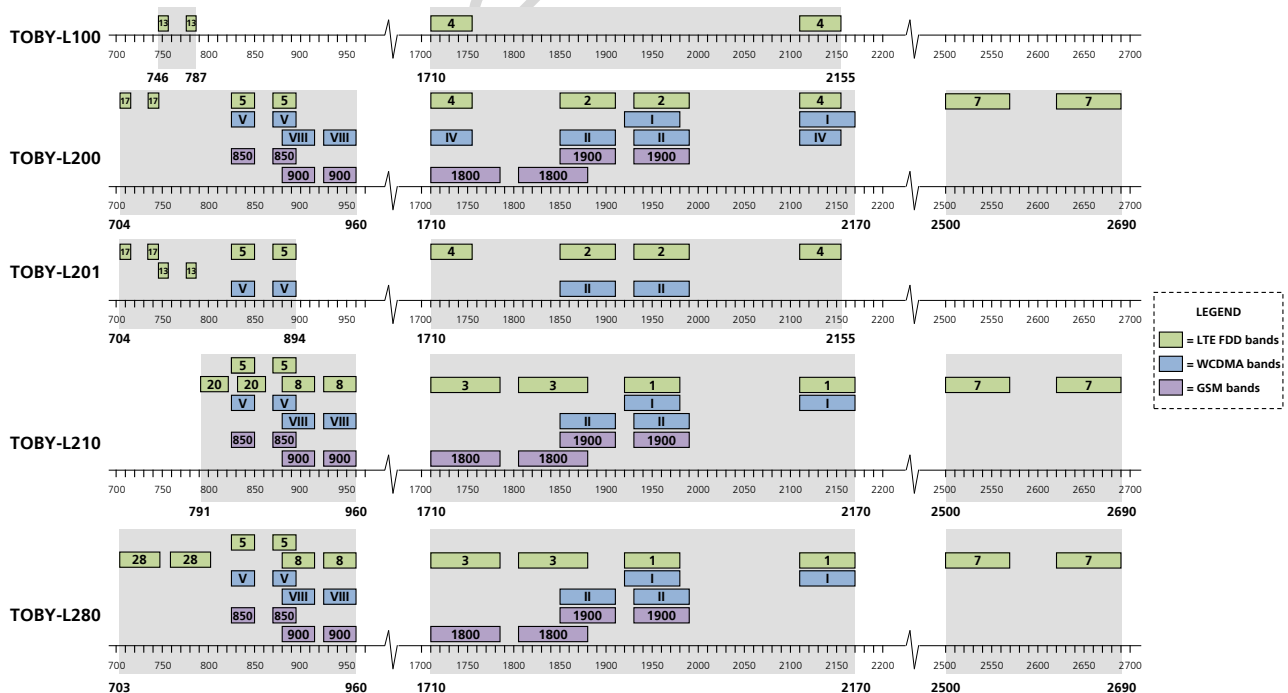

Figure 84: Summary of TOBY-L1 and TOBY-L2 series modules LTE, 3G and 2G operating frequency bands

B.2 Pin-out comparison between TOBY-L1 and TOBY-L2

Pin No	TOBY-L1 Pin Name	Description	TOBY-L2 Pin Name	Description	Remarks for migration
1	RSVD	Reserved	RSVD	Reserved	
2	GND	Ground	GND	Ground	
3	V_BCKP	RTC Supply Output 2.5 V output only RTC backup function not available	V_BCKP	RTC Supply Input/Output 3.0 V output 1.4 V – 4.2 V input (RTC backup)	RTC back-up: No → Yes
4	RSVD	Reserved	VUSB_DET	VBUS USB supply (5 V) detection ⁸	No difference: leave unconnected as reserved or not supported
5	V_INT	Interfaces Supply Output 1.8 V output	V_INT	Interfaces Supply Output 1.8 V output	No functional difference
6	RSVD	Reserved	RSVD	Reserved This pin must be connected to GND	No connect → Connect to GND
7-9	RSVD	Reserved	RSVD	Reserved	
10	RSVD	Reserved	DSR	UART DSR Output ⁹ / GPIO ⁸	Reserved → UART / GPIO
11	RSVD	Reserved	RI	UART RI Output ¹⁰ / GPIO ⁸	Reserved → UART / GPIO
12	RSVD	Reserved	DCD	UART DCD Output ⁹ / GPIO ⁸	Reserved → UART / GPIO
13	RSVD	Reserved	DTR	UART DTR Input ⁹ / GPIO ⁸	Reserved → UART / GPIO
14	RSVD	Reserved	RTS	UART RTS Input ¹⁰	Reserved → UART
15	RSVD	Reserved	CTS	UART CTS Output ¹⁰	Reserved → UART
16	RSVD	Reserved	TXD	UART Data Input ¹⁰	Reserved → UART
17	RSVD	Reserved	RXD	UART Data Output ¹⁰	Reserved → UART
18-19	RSVD	Reserved	RSVD	Reserved	
20	PWR_ON	Power-on Input No internal pull-up	PWR_ON	Power-on Input Internal 50k pull-up to VCC	Pull-up: External → Internal
21	GPIO1	GPIO ¹¹ WWAN status indication on “00” product version	GPIO1	GPIO ⁸ WWAN status indication on “00” and “01” product versions Wi-Fi enable on “50” version	No functional difference
22	GPIO2	GPIO ¹¹	GPIO2	GPIO ⁸	
23	RESET_N	Reset signal Input Internal 10k pull-up to V_BCKP Switch-off function only	RESET_N	Reset signal Input Internal 50k pull-up to VCC Reset, Switch-on, Switch-off	Internal pull-up: V_BCKP → VCC Switch-off → Reset, Switch-on/off
24	GPIO3	GPIO ¹¹	GPIO3	GPIO ⁸	
25	GPIO4	GPIO ¹¹	GPIO4	GPIO ⁸	
26	RSVD	Reserved	HOST_SELECT0	Input for selection of module configuration by the host ⁸	Reserved → HOST_SELECT0
27	USB_D-	USB Data I/O (D-)	USB_D-	USB Data I/O (D-)	No functional difference
28	USB_D+	USB Data I/O (D+)	USB_D+	USB Data I/O (D+)	No functional difference
29	RSVD	Reserved	RSVD	Reserved	
30	GND	Ground	GND	Ground	
31	RSVD	Reserved	RSVD	Reserved	
32	GND	Ground	GND	Ground	
33-43	RSVD	Reserved	RSVD	Reserved	
44	GND	Ground	GND	Ground	
45	RSVD	Reserved	RSVD	Reserved	
46	GND	Ground	GND	Ground	
47-49	RSVD	Reserved	RSVD	Reserved	
50	RSVD	Reserved	I2S_WA	I ² S Word Alignment ⁸ / GPIO ⁸	Reserved → I2S / GPIO
51	RSVD	Reserved	I2S_TXD	I ² S Data Output ⁸ / GPIO ⁸	Reserved → I2S / GPIO
52	RSVD	Reserved	I2S_CLK	I ² S Clock ⁸ / GPIO ⁸	Reserved → I2S / GPIO
53	RSVD	Reserved	I2S_RXD	I ² S Data Input ⁸ / GPIO ⁸	Reserved → I2S / GPIO

⁸ Not supported by “00”, “01”, “50” product versions

⁹ Not supported by TOBY-L200-00S, TOBY-L210-00S, TOBY-L200-50S, TOBY-L210-50S

¹⁰ Not supported by TOBY-L200-00S, TOBY-L210-00S

¹¹ Not supported by “00” product version

TOBY-L1			TOBY-L2		
Pin No	Pin Name	Description	Pin Name	Description	Remarks for migration
54	RSVD	Reserved	SCL	I ² C Clock Output ¹²	Reserved → I2C
55	RSVD	Reserved	SDA	I ² C Data I/O ¹²	Reserved → I2C
56	SIM_CLK	SIM Clock Output	SIM_CLK	SIM Clock Output	No functional difference
57	SIM_IO	SIM Data I/O	SIM_IO	SIM Data I/O	No functional difference
58	SIM_RST	SIM Reset Output	SIM_RST	SIM Reset Output	No functional difference
59	VSIM	SIM Supply Output	VSIM	SIM Supply Output	No functional difference
60	GPIO5	GPIO ¹³	GPIO5	GPIO ¹² SIM detection	
61	GPIO6	GPIO ¹³	GPIO6	GPIO ¹²	
62	RSVD	Reserved	HOST_SELECT1	Input for selection of module configuration by the host ¹²	Reserved → HOST_SELECT1
63	RSVD	Reserved	SDIO_D2	SDIO serial data [2] ¹⁴	Reserved → SDIO
64	RSVD	Reserved	SDIO_CLK	SDIO serial clock ¹⁴	Reserved → SDIO
65	RSVD	Reserved	SDIO_CMD	SDIO command ¹⁴	Reserved → SDIO
66	RSVD	Reserved	SDIO_D0	SDIO serial data [0] ¹⁴	Reserved → SDIO
67	RSVD	Reserved	SDIO_D3	SDIO serial data [3] ¹⁴	Reserved → SDIO
68	RSVD	Reserved	SDIO_D1	SDIO serial data [1] ¹⁴	Reserved → SDIO
69	GND	Ground	GND	Ground	
70-72	VCC	Module Supply Input 3.40 V – 4.50 V normal range No 2G current pulses No switch-on applying VCC	VCC	Module Supply Input 3.40 V – 4.35 V normal range High 2G current pulses Switch-on applying VCC	No VCC functional difference
73-74	GND	Ground	GND	Ground	
75	RSVD	Reserved	ANT_DET	Antenna Detection Input ¹²	Reserved → ANT_DET
76	GND	Ground	GND	Ground	
77	RSVD	Reserved	RSVD	Reserved	
78-80	GND	Ground	GND	Ground	
81	ANT1	RF Antenna Input/Output Two LTE bands No 3G bands No 2G bands	ANT1	RF Antenna Input/Output Up to six LTE bands Up to five 3G bands Four 2G bands	No RF functional difference Different operating bands support
82-83	GND	Ground	GND	Ground	
84	RSVD	Reserved	RSVD	Reserved	
85-86	GND	Ground	GND	Ground	
87	ANT2	RF Antenna Input LTE MIMO 2x2 No 3G Rx diversity	ANT2	RF Antenna Input LTE MIMO 2x2 3G Rx diversity	No RF functional difference Different operating bands support
88-90	GND	Ground	GND	Ground	
91	RSVD	Reserved	RSVD	Reserved	
92-152	GND	Ground	GND	Ground	

Table 50: TOBY-L1 and TOBY-L2 pin assignment with remarks for migration
¹² Not supported by "00", "01", "50" product versions

¹³ Not supported by "00" product version

¹⁴ Not supported by "00", "01" product versions

B.3 Schematic for TOBY-L1 and TOBY-L2 integration

Figure 85 shows an example schematic diagram where a TOBY-L1 series module ("00" product version) or a TOBY-L2 series module ("00", "01" or "50" product versions) can be integrated into the same application board, using all the available interfaces and functions of the module. The different mounting options for the external parts are highlighted in different colors as described in the legend, according to the interfaces supported by the different module product versions.

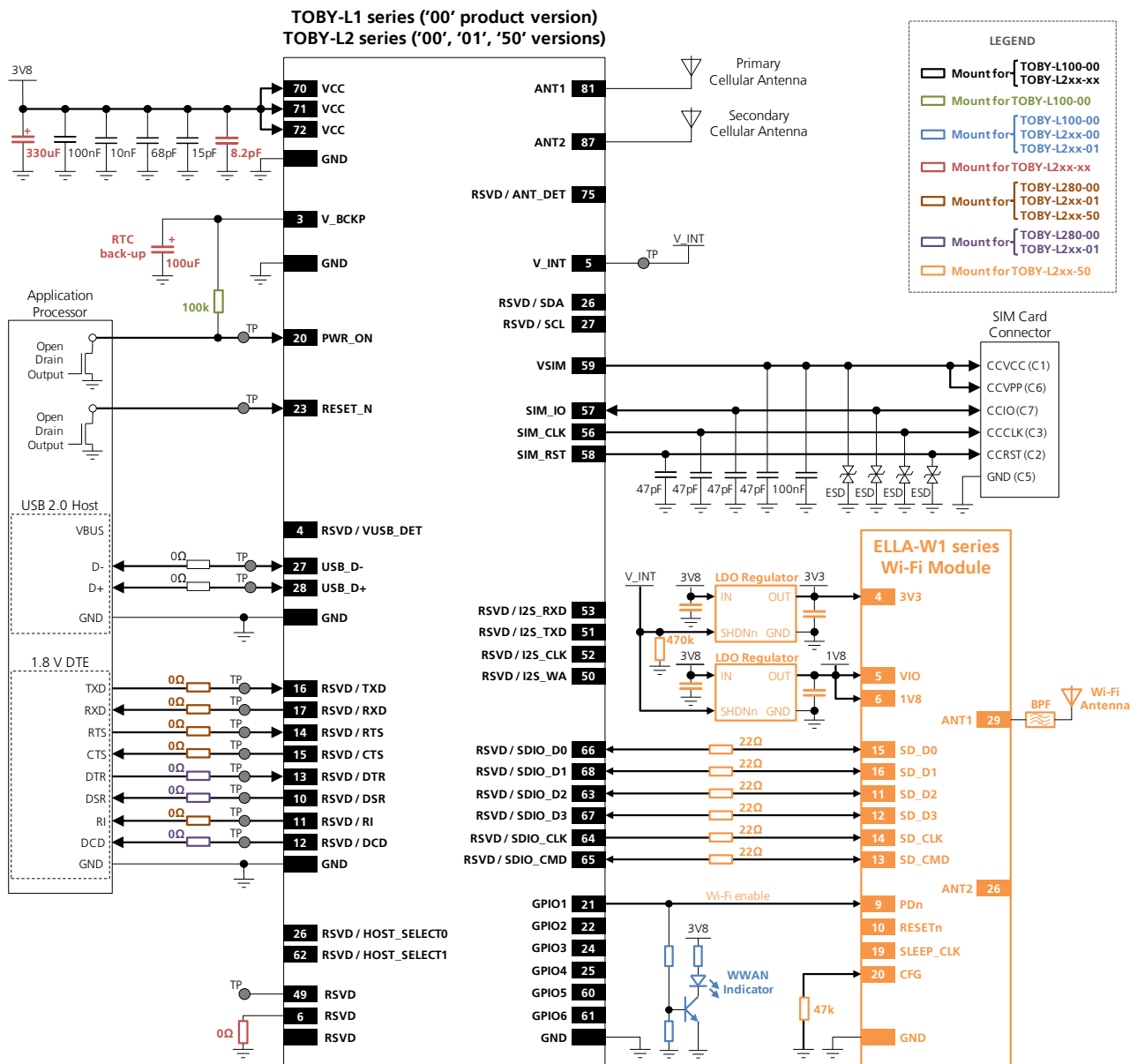

Figure 85: Example of complete schematic diagram to integrate TOBY-L1 modules ("00" product version) and TOBY-L2 modules ("00", "01" or "50" product versions) on the same application board, using all the available interfaces / functions of the modules

Related documents

- [1] u-blox TOBY-L2 series Data Sheet, Docu No UBX-13004573
- [2] u-blox MPC1-L2 series Data Sheet, Docu No UBX-13004749
- [3] u-blox AT Commands Manual, Docu No UBX-13002752
- [4] u-blox EVK-L20 / EVK-L21 User Guide, Docu No UBX-14000422
- [5] u-blox Firmware Update Application Note, Docu No UBX-13001845
- [6] Universal Serial Bus Revision 2.0 specification, http://www.usb.org/developers/docs/usb20_docs/
- [7] ITU-T Recommendation V.24 - 02-2000 - List of definitions for interchange circuits between Data Terminal Equipment (DTE) and Data Circuit-terminating Equipment (DCE), <http://www.itu.int/rec/T-REC-V.24-200002-l/en>
- [8] 3GPP TS 27.007 - AT command set for User Equipment (UE)
- [9] 3GPP TS 27.005 - Use of Data Terminal Equipment - Data Circuit terminating; Equipment (DTE - DCE) interface for Short Message Service (SMS) and Cell Broadcast Service (CBS)
- [10] 3GPP TS 27.010 - Terminal Equipment to User Equipment (TE-UE) multiplexer protocol
- [11] u-blox Mux Implementation Application Note, Docu No UBX-13001887
- [12] I²C-bus specification and user manual - Rev. 5 - 9 October 2012 - NXP Semiconductors, http://www.nxp.com/documents/user_manual/UM10204.pdf
- [13] u-blox GNSS Implementation Application Note, Docu No UBX-13001849
- [14] u-blox Wi-Fi / Cellular Integration Application Note, Docu No UBX-14003264
- [15] PCI Express Mini Card Electromechanical Specification, Revision 2.0, April 21, 2012
- [16] 3GPP TS 26.267 – eCall Data Transfer; In-band modem solution; General description
- [17] BS EN 16062:2011 – Intelligent transport systems – eSafety – eCall high level application requirements
- [18] ETSI TS 122 101 – Service aspects; Service principles (3GPP TS 22.101)
- [19] u-blox eCall / ERA-GLONASS Application Note, Docu No UBX-13001924
- [20] SIM Access Profile Interoperability Specification, <http://www.bluetooth.org/>
- [21] GSM Association TS.09 - Battery Life Measurement and Current Consumption Technique <http://www.gsma.com/newsroom/wp-content/uploads/2013/09/TS.09-v7.6.pdf>
- [22] CENELEC EN 61000-4-2 (2001): "Electromagnetic compatibility (EMC) – Part 4-2: Testing and measurement techniques – Electrostatic discharge immunity test".
- [23] ETSI EN 301 489-1 V1.8.1: "Electromagnetic compatibility and Radio spectrum Matters (ERM); EMC standard for radio equipment and services; Part 1: Common technical requirements"
- [24] ETSI EN 301 489-7 V1.3.1 "Electromagnetic compatibility and Radio spectrum Matters (ERM); EMC standard for radio equipment and services; Part 7: Specific conditions for mobile and portable radio and ancillary equipment of digital cellular radio telecommunications systems"
- [25] ETSI EN 301 489-24 V1.4.1 "Electromagnetic compatibility and Radio spectrum Matters (ERM); EMC standard for radio equipment and services; Part 24: Specific conditions for IMT-2000 CDMA Direct Spread (UTRA) for Mobile and portable (UE) radio and ancillary equipment"
- [26] 3GPP TS 51.010-2 - Technical Specification Group GSM/EDGE Radio Access Network; Mobile Station (MS) conformance specification; Part 2: Protocol Implementation Conformance Statement (PICS)
- [27] 3GPP TS 34.121-2 - Technical Specification Group Radio Access Network; User Equipment (UE) conformance specification; Radio transmission and reception (FDD); Part 2: Implementation Conformance Statement (ICS)
- [28] 3GPP TS 36.521-2 - Evolved Universal Terrestrial Radio Access (E-UTRA); User Equipment conformance specification; Radio transmission and reception; Part 2: Implementation Conformance Statement (ICS)
- [29] 3GPP TS 36.523-2 - Evolved Universal Terrestrial Radio Access (E-UTRA) and Evolved Packet Core (EPC); User Equipment conformance specification; Part 2: Implementation Conformance Statement (ICS)
- [30] u-blox End user test Application Note, Docu No UBX-13001922
- [31] u-blox Package Information Guide, Docu No UBX-14001652
- [32] u-blox Nested Design Application Note, Docu No UBX-13002795

Some of the above documents can be downloaded from u-blox web-site (<http://www.u-blox.com/>).

Revision history

Revision	Date	Name	Status / Comments
R01	20-Dec-2013	sses	Initial release for TOBY-L2 series
R02	21-Mar-2014	sses	Initial release including MPC1-L2 series UART and GPIOs remarked as not supported by TOBY-L2x0-00S
R03	23-Jul-2014	sses	Advance Information document status Updated MPC1-L2 descriptions Updated USB description and design-in, including VUSB_DET pin previously RSVD Updated MPC1-L2 thickness and installation guidelines Updated MPC1-L2 power-off procedure Updated MPC1-L2 pins 3, 5, 44, 46 definition: Not Connected instead of GPI/GPO Updated GPIOs definition and description Additional design-in examples, minor corrections and improvements
R04	30-Sep-2014	lpah	Updated FW version for Engineering Samples Additional design-in and minor corrections
R05	28-Nov-2014	lpah / sses	Changed status to Early Production Information Updated VUSB_DET description and application circuits: the VUSB_DET functionality is not supported, and the pin should be left unconnected or it should not be driven high Added maximum antenna gain requirements as per FCC RF radiation exposure limits Corrected MPC1-L2 pinout Additional design-in and minor corrections
R06	28-Jan-2015	sses	Added description and design-in for TOBY-L2xx-50S, i.e. the "50" product version: updated UART, SDIO, GPIO sections
R07	29-May-2015	sses	Added description and design-in for TOBY-L280-00S and TOBY-L201-01S: updated UART, FTP, HTTP, FOTA sections and any other applicable section
R07	29-Jun-2015	sses	

Contact

For complete contact information visit us at <http://www.u-blox.com/>

u-blox Offices

North, Central and South America

u-blox America, Inc.

Phone: +1 703 483 3180
E-mail: info_us@u-blox.com

Regional Office West Coast:

Phone: +1 408 573 3640
E-mail: mailto:info_us@u-blox.com

Technical Support:

Phone: +1 703 483 3185
E-mail: mailto:support_us@u-blox.com

Headquarters

Europe, Middle East, Africa

u-blox AG

Phone: +41 44 722 74 44
E-mail: info@u-blox.com
Support: mailto:support@u-blox.com

Asia, Australia, Pacific

u-blox Singapore Pte. Ltd.

Phone: +65 6734 3811
E-mail: info_ap@u-blox.com
Support: support_ap@u-blox.com

Regional Office Australia:

Phone: +61 2 8448 2016
E-mail: info_anz@u-blox.com
Support: support_ap@u-blox.com

Regional Office China (Beijing):

Phone: +86 10 68 133 545
E-mail: info_cn@u-blox.com
Support: support_cn@u-blox.com

Regional Office China (Shenzhen):

Phone: +86 755 8627 1083
E-mail: info_cn@u-blox.com
Support: support_cn@u-blox.com

Regional Office India:

Phone: +91 959 1302 450
E-mail: mailto:info_in@u-blox.com
Support: mailto:support_in@u-blox.com

Regional Office Japan:

Phone: +81 3 5775 3850
E-mail: info_jp@u-blox.com
Support: support_jp@u-blox.com

Regional Office Korea:

Phone: +82 2 542 0861
E-mail: info_kr@u-blox.com
Support: support_kr@u-blox.com

Regional Office Taiwan:

Phone: +886 2 2657 1090
E-mail: info_tw@u-blox.com
Support: support_tw@u-blox.com