



## Universal embedded WLAN solution for OEM customers

### WiBear-SF - Industrial universal WLAN front end module (IEEE 802.11b/g)



The lesswire industrial universal WiBear-SF- WLAN module is a reliable, automotive grade WLAN front end module. The module is developed for use in industrial temperature range from -40°C to +85°C.

The WiBear-SF WLAN module features the following key benefits:

- Extremely small and efficient footprint which covers 20 x 20 mm of size
- Simultaneous use of two different leading wireless standards, the IEEE 802.11b,g WLAN and a full featured Bluetooth IEEE802.15.1 class 2 transceiver.
- Micro Access Point feature for building WLAN networks with the maximum number of 8 clients

The WiBear-SF WLAN module may be integrated in two ways into customer solutions:

- Deploy the processor of the existing design as host controller: The WLAN-SF module is connected to the customer processor by SDIO or G-SPI interfaces. The WLAN stack will run on processor of the existing design.
- Add the WiBear-SF WLAN module together with a host controller to an existing design. As an example, the host controller may be based on ARM9 core. A corresponding reference design is available on request.

The host controller selection can consider additional needed interfaces like Ethernet, USB, CAN, or UART. The WiBear-SF WLAN module is designed for industrial solutions in order to connect with already existing WLAN networks on shop floor. Furthermore, an embedded Linux-based Web Server reference application is available to easily implement user-interfaces for WLAN module configuration. The Bluetooth interface supports Bluetooth 2.1 and Enhanced Data Rate (EDR) operation. The WiBear-SF complies with Bluetooth stacks that support SDIO or UART HCI protocol.

The WiBear-SF module is a compact one-side assembled design and can be soldered (SMD) onto a customer boards. The availability of the module is guaranteed for minimum of 6 years

The universal WLAN module saves time and reduces costs. OEM customers can concentrate on their core competence while adopting this easy to use WLAN module that can enable many wireless applications. For larger quantity orders lesswire can also provide module design-ins. Driver porting to other operating systems can be offered by lesswire.

#### Description of technical parameters

##### WLAN

- |               |                      |              |
|---------------|----------------------|--------------|
| • IEEE802.11b | Output power:        | typ. +18 dBm |
|               | Sensitivity: @ 1Mbps | typ. -96 dBm |
|               | Sensitivity: @11Mbps | typ. -89dBm  |
| • IEEE802.11g | Output power:        | typ. +15 dBm |
|               | Sensitivity: @ 6Mbps | typ. -90dBm  |
|               | Sensitivity: @12Mbps | typ. -88dBm  |
|               | Sensitivity: @54Mbps | typ. -73dBm  |

##### Bluetooth

- |                |                           |                     |
|----------------|---------------------------|---------------------|
| • IEEE802.15.1 | Output power:             | typ. +8dBm          |
|                | Sensitivity EDR           | typ. -75dBm         |
|                | Sensitivity BDR           | typ. -86dBm         |
|                | Bluetooth device class 2: | typ. range ~10-20 m |
|                | Frequency range           | 2402MHz to 2480MHz  |
|                | Number of channels        | 79                  |
|                | Modulation                | FHSS                |

##### Reference Designs

- SDIO / G-SPI Evaluation Board
- Reference design ARM9, 10 Mbps Ethernet, CAN, USB, and Linux 2.6.28 including Linux BSP, drivers

##### Interfaces

- |         |                         |
|---------|-------------------------|
| • SDIO  | • Bluetooth coexistence |
| • G-SPI | • UART                  |

##### Driver Support

- Linux 2.6.x
- Windows CE, Windows XP/Vista

##### Bluetooth stack support

- Bluetooth 2.1 Basic Data Rate (BDR) and Enhanced Data Rate (EDR) operation
- Bluetooth stacks that support UART HCI protocol



## Description of technical parameters (continuation)

### RF properties achieved by

- Integrated additional PA / LNA 2.4GHz
- Integrated reference high precision frequency generator

### WLAN/Bluetooth coexistence feature

- Hardware based coexistence support by 2-wire, 3-wire, or 4-wire interfaces

### Two firmware (FW) options

- WLAN STA infrastructure and ad-hoc mode including support for parallel Bluetooth operation; Bluetooth may be disabled
- WLAN  $\mu$ AP mode supports up to 8 WLAN stations, Bluetooth may be disabled in  $\mu$ AP mode

### Antenna

- WLAN STA mode  
ANT1 - WLAN and Bluetooth, ANT2 - not used
- WLAN  $\mu$ AP mode  
ANT1 – WLAN, ANT2 - Bluetooth

### User interface

- Embedded Linux based Web Server as configuration interface on separated ARM9 host as reference application

### Configuration/Programming

- Configuration over WLAN or wired interfaces based on the host controller
- External FW storage on host
- Fast FW download at power-on

### Digital interfaces to host controller

- 4-bit SDIO interface (default); Optional SDIO 1-bit and SDIO-SPI host controller interfaces
- Optional G-SPI in slave mode for synchronous communication with communication processor
- Bluetooth may be used over SDIO or UART HCI interfaces.

### Product options

- WLAN / Bluetooth; commercial operating temperature range (default)
- WLAN / Bluetooth; industrial operating temperature range
- WLAN; commercial temperature range
- WLAN; industrial temperature range

### Profile view

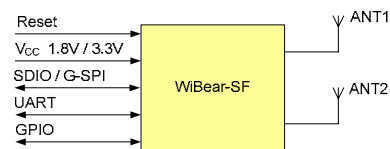
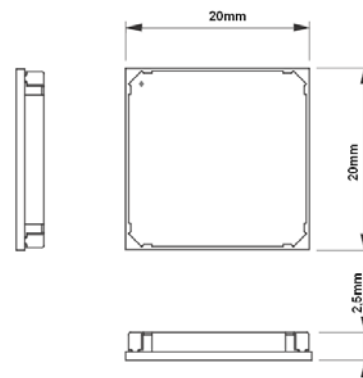

## Technical data

WLAN standards:	IEEE 802.11b, g IEEE 802.11i, e, j, h, s (IEEE802.11-2007)
Data transfer rate:	IEEE 802.11b: 11, 5.5, 2, 1 Mbps IEEE802.11g: 54, 48, 36, 24, 18, 12, 9, 6 Mbps
Frequency range:	2.4 – 2.497 GHz (ISM Band)
Protocols:	Enables Ethernet NIC on host
Host interfaces:	SDIO (default), G- SPI alternatively SDIO/UART for Bluetooth
Antenna:	QFN antennae pads
Mounting technology:	SMD soldering
Management:	According to IEEE802.11
Modulation:	OFDM, DSSS/CCK

Power supply:	Vcc 3.3V and 1.8V
Operating Temperature	Industrial temperature option -40°C to +85°C Commercial temperature option 0°C to +70°C
Storage temperature	-55°C to +105°C
Firmware:	At system power-on firmware is downloaded from host..
Security encryption:	WEP 64/128 Bit-Key, WPA (TKIP, AES), WPA2 (CCMP, AES)
Dimensions (LxBxH):	20mm x 20mm x 2.5mm
Scope of delivery:	Embedded WLAN module



## 45 PIN QFN Host Interface

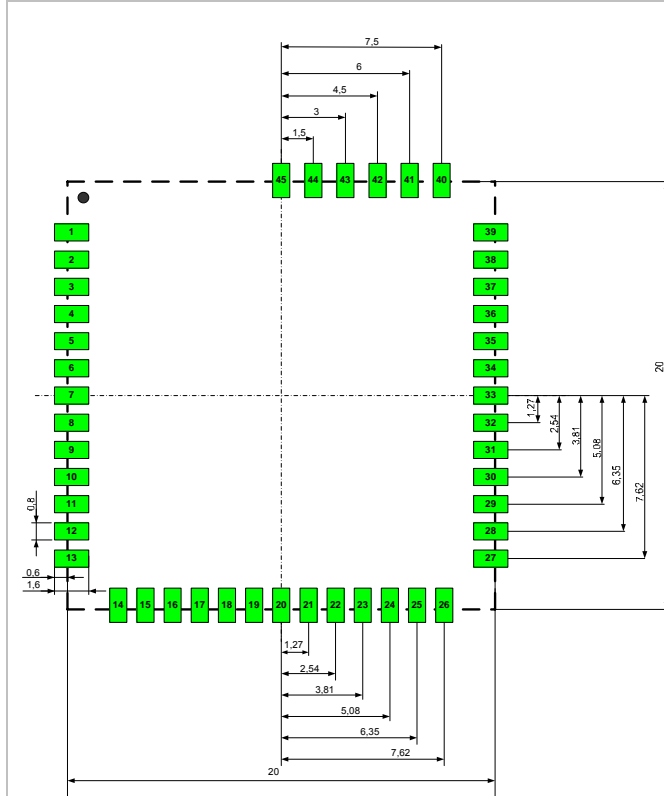

Mechanical drawing: Footprint on mother board

### General purpose IO

PIN	Signal	Description
19	GPIO[3] <sup>3</sup>	General purpose IO
20	GPIO[4]	General purpose IO
21	GPIO[5] <sup>3</sup>	General purpose IO
22	GPIO[16]	General purpose IO
27	GPIO[0]	General purpose IO
29	GPIO[9]	General purpose IO
30	GPIO[10]	General purpose IO

### Bluetooth Coexistence

PIN	Signal	Description
37	BT_PRIORITY	Bluetooth priority
38	BT_STATE	Bluetooth state
36	BT_FREQ	Bluetooth frequency
39	WL_ACTIVE	Bluetooth WLAN active

### Power Supply

PIN	Signal	Description
12, 13, 26	GND	Ground
9	3V3	Module power supply +3.3V
10	VIO	Module I/O supply (3.3V or 1.8V)
11	1V8	Module power supply +1.8V

### SDIO- / G-SPI Interface

PIN	Signal	Description
1	SD_D2 / SPI_SINTn <sup>1</sup>	SDIO 4-bit mode: Data line Bit 2
2	SD_D3 / SPI_CLK_REQ <sup>1</sup>	SDIO 4-bit mode: Data line Bit 3
3	SD_CMD / SPI_SDI <sup>1</sup>	SDIO 4-bit mode: Command/Response
4	SD_CLK / SPI_CLK <sup>1</sup>	SDIO 4-bit mode: Clock
5	SD_D0 / SPI_SCSn <sup>1</sup>	SDIO 4-bit mode: Data line Bit 0
6	SD_D1 / SPI_SDO <sup>1</sup>	SDIO 4-bit mode: Data line Bit 1

### LED

PIN	Signal	Description
23	GPIO[17]/BT_LED	LED function set by firmware
28	GPIO[1]/WLAN_LED	LED function set by firmware

### Control

PIN	Signal	Description
8	PDn	Power Down
7	RESETn	Module reset
14	SLEEP_CLK <sup>2</sup>	Input for external sleep clock

### Bluetooth UART (max. up to 4Mbps)

PIN	Signal	Description
15	GPIO[2]/UART_RTS	UART RTS Output
16	GPIO[6]/UART_SOUT	UART SOUT Output
17	GPIO[7]/UART_SINT	UART SINT Input
18	GPIO[8]/UART_CTS	UART CTS Input

### Audio Interface Unit / Inter IC Sound

PIN	Signal	Description
31	GPIO[11]/BT_PCM_DIN	PCM Data Input signal
32	GPIO[12]/BT_PCM_DOUT	PCM Data Output signal
33	GPIO[13]/BT_PCM_CLK	PCM Clock Signal, output if master
34	GPIO[14]/BT_PCM_SYNC	PCM Sync Pulse signal
35	GPIO[15]/BT_PCM_MCLK	PCM Clock signal (optional for some Codecs)

### Antennae

PIN	Signal	Description
40	GND	Antenna ground
41	ANT2 (BT only)	Bluetooth antenna in $\mu$ AP working mode
42	GND	Antenna ground
43	GND	Antenna ground
44	ANT1 (WLAN / WLAN+BT)	WLAN/Bluetooth antenna in station mode
45	GND	Antenna ground

### Notes:

<sup>1</sup> Signal description provided for SDIO 4-bit / G-SPI mode. SDIO-SPI and SDIO -1bit mode are also supported.

<sup>2</sup> External sleep clock for WLAN can be generated by internal clock source or may be provided by an external clock source. For Bluetooth operation in power save mode an external sleep clock is required (without power save an external clock for Bluetooth is not necessary). For Bluetooth Power Save mode external sleep clock 32.000 or 32.768 kHz frequency with tolerance  $\pm 50$ ppm is needed (ordinary watch fork quartz crystal conform to  $\pm 50$ ppm requirements at room temperature only, please check temperature characteristics before use). For WLAN external sleep clock any clock source with tolerance  $\pm 5000$ ppm can be used (Note that in this case internal sleep clock with the similar tolerance can be used as well).

<sup>3</sup> Can be used as UART\_DSR Input (GPIO[3]), UART\_DTR Output (GPIO[5]) and as Bluetooth Wake-Up signals.

Part number: AN00973535

