

# Workstation 5

Powerful Virtual Machine Software for the Technical Professional

## User's Manual

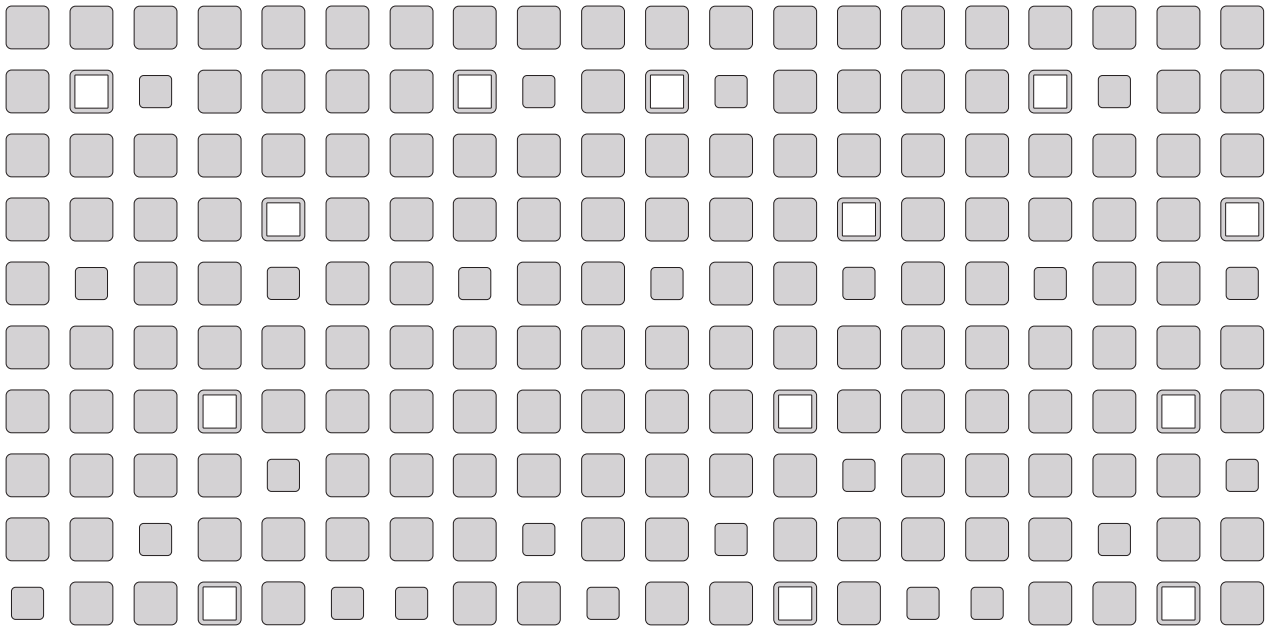

**VMware, Inc.**

3145 Porter Drive  
Palo Alto, CA 94304  
www.vmware.com

**Please note that you can always find the most up-to-date technical documentation on our Web site at <http://www.vmware.com/support/>.**

**The VMware Web site also provides the latest product updates.**

Copyright © 1998-2005 VMware, Inc. All rights reserved. Protected by one or more of U.S. Patent Nos. 6,397,242, 6,496,847, 6,704,925, 6,711,672, 6,725,289, 6,735,601, 6,785,886, 6,789,156 and 6,795,966; patents pending. VMware, the VMware "boxes" logo and design, Virtual SMP and VMotion are registered trademarks or trademarks of VMware, Inc. in the United States and/or other jurisdictions. Microsoft, Windows and Windows NT are registered trademarks of Microsoft Corporation. Linux is a registered trademark of Linus Torvalds. All other marks and names mentioned herein may be trademarks of their respective companies.  
Revision: 20050916 Version: 5.0 Item: WS-ENG-Q205-062

# Table of Contents

<b>Introduction and System Requirements</b>	<b>15</b>
Product Overview	16
Powerful Virtual Machine Software for the Technical Professional	16
Overview of This Manual	18
About the Host and Guest Computers	18
What's New in Version 5	19
Multiple Snapshots	19
Teams	19
Clones	19
Improved Performance for Virtual Machines Running Concurrently	20
Improved Networking Performance	20
Improved Suspend/Resume and Snapshot Operations	20
New Host Operating System Support	20
New Guest Operating System Support	20
Improved 64-bit Host Support	21
Isochronous USB support	21
Command Line Interface	21
Movie Record and Playback	21
Improved Linux User Interface	21
Easier Upgrades and VMware Tools Installation Improvements	22
Support for NX bit	22
Experimental Support for Direct3D	22
Experimental Support for Guest ACPI S1 Sleep	22
VMware Virtual Machine Importer	22
Host System Requirements	23
PC Hardware	23
Memory	23
Display	23
Disk Drives	24
Local Area Networking (Optional)	24
Host Operating System	24
Virtual Machine Specifications	27
Processor	27
Chip Set	27
BIOS	27

Memory	27
Graphics	27
IDE Drives	27
SCSI Devices	28
Floppy Drives	28
Serial (COM) Ports	28
Parallel (LPT) Ports	28
USB ports	28
Keyboard	28
Mouse and Drawing Tablets	28
Ethernet Card	29
Sound	29
Virtual Networking	29
Supported Guest Operating Systems	30
Microsoft Windows 32-bit	30
Microsoft MS-DOS	30
Linux	31
Novell Netware	31
FreeBSD	31
Sun Solaris	31
Technical Support Resources	32
Documentation on the Web	32
VMware Knowledge Base	32
VMware User Community	32
Reporting Problems	32
Where to Go Next	34
<b>Installing VMware Workstation</b>	<b>35</b>
Selecting Your Host System	36
Upgrading from Previous Versions	36
Workstation Cannot Share a Host with Other VMware Products	36
Installing VMware Workstation 5 on a Windows Host	37
Installing Workstation on a Windows Host	38
Installing VMware Workstation Silently	41
Uninstalling VMware Workstation 5 on a Windows Host	43
Installing VMware Workstation 5 on a Linux Host	44
Before Installing on a Linux Host	45
Installing Workstation on a Linux Host	45

Configuring with vmware-config.pl _____	48
Web Browser Required _____	48
Uninstalling VMware Workstation 5 on a Linux Host _____	49
Where to Go Next _____	50
<b>Upgrading VMware Workstation _____</b>	<b>51</b>
Preparing for the Upgrade _____	52
Before You Install VMware Workstation 5 _____	52
Upgrading on a Windows Host _____	55
Upgrading from Version 4 or an Earlier Version 5 Release _____	55
Upgrading from Version 3 to Version 5 _____	55
Upgrading on a Linux Host _____	56
Using Workstation 4 Virtual Machines in Workstation 5 _____	57
Create Everything New from the Start _____	57
Use a Legacy Virtual Machine without Upgrading _____	57
Use a Legacy Virtual Machine with Upgrade _____	58
Where to Go Next _____	60
<b>Learning VMware Workstation Basics _____</b>	<b>61</b>
Launching VMware Workstation _____	62
Launching VMware Workstation on a Windows Host _____	62
Launching VMware Workstation on a Linux Host _____	63
Overview of the VMware Workstation Window _____	64
The Home Page, Summary View, and Console View _____	66
The Toolbar _____	69
The Favorites List _____	71
Checking for Product Updates _____	75
Setting Preferences for VMware Workstation _____	76
Workspace _____	77
Input _____	78
Hot Keys _____	78
Display _____	79
Memory _____	80
Priority _____	81
Lockout (Windows Hosts Only) _____	82
Virtual Machine Settings _____	83
Hardware _____	83
Options _____	84

Command Line Reference _____	91
Startup Options on a Linux Host _____	91
Startup Options on a Windows Host _____	92
Command Line Application _____	93
Keyboard Shortcuts _____	95
What Files Make Up a Virtual Machine? _____	96
Where to Go Next _____	99
<b>Creating a New Virtual Machine _____</b>	<b>101</b>
Setting Up a New Virtual Machine _____	102
Steps to a New Virtual Machine _____	102
Converting a VirtualPC Virtual Machine _____	113
Installing a Guest Operating System and VMware Tools _____	117
Example: Installing Windows XP as a Guest Operating System _____	117
Installing VMware Tools _____	120
Upgrading VMware Tools _____	120
VMware Tools for Windows Guests _____	120
VMware Tools for Linux Guests _____	122
VMware Tools for FreeBSD Guests _____	127
Installing VMware Tools in a NetWare Virtual Machine _____	129
VMware Tools Configuration Options _____	130
Using the Control Panel to Configure VMware Tools _____	130
Using the System Console to Configure VMware Tools in a NetWare Guest Operating System _____	135
Where to Go Next _____	137
_____ <b>Running VMware Workstation 139</b>	
Starting a Virtual Machine _____	141
Virtual Machine Location _____	141
Checking the Status of VMware Tools _____	142
Suspending and Resuming Virtual Machines _____	143
Shutting Down a Virtual Machine _____	144
Power Off vs. Shut Down _____	144
Resetting a Virtual Machine _____	145
Reset vs. Restart _____	145

Taking and Reverting to a Snapshot _____	146
Cloning a Virtual Machine _____	147
Deleting a Virtual Machine _____	148
Using Virtual Machine Teams _____	149
Controlling the Display _____	150
Using Full Screen Mode _____	150
Using Quick Switch Mode _____	151
Taking Advantage of Multiple Monitors _____	151
Fitting the Workstation Console to the Virtual Machine Display _____	152
Nonstandard Resolutions _____	153
Simplifying the Screen Display _____	153
Installing New Software _____	155
Cutting, Copying and Pasting Text _____	156
Using Shared Folders _____	157
Viewing a Shared Folder _____	161
Using Drag and Drop _____	163
Using Devices in a Virtual Machine _____	164
Adding, Configuring, and Removing Devices in a Virtual Machine _____	164
Connecting and Disconnecting Removable Devices _____	164
Creating a Screen Shot or a Movie of a Virtual Machine _____	165
Creating a Screen Shot of a Virtual Machine _____	165
Creating a Movie of a Virtual Machine _____	165
Where to Go Next _____	167
<b>Moving and Sharing Virtual Machines _____</b>	<b>169</b>
Virtual Machine Identifier — UUID _____	170
The UUID Location and Format _____	170
The UUID and Moving Virtual Machines _____	171
Specifying a UUID for a Virtual Machine _____	172
Setting the UUID for a Virtual Machine that Is Being Moved _____	172
Moving a VMware Workstation 5 Virtual Machine _____	173
Hosts with Different Hardware _____	173
Virtual Machines Use Relative Paths _____	174
Preparing a Workstation 5 Virtual Machine for a Move _____	174
Moving a Workstation 5 Virtual Machine to a New Host _____	175
Moving a VMware Workstation 4 Virtual Machine _____	176
Preparing Your Workstation 4 Virtual Machine for the Move _____	177
Moving a Workstation 4 Virtual Machine to a New Host Machine _____	178

Moving an Older Virtual Machine _____	179
Moving VMware Workstation 3.0 Virtual Machines _____	179
Moving VMware Workstation 2.x Virtual Machines _____	181
Considerations for Moving Workstation Disks in Undoable Mode _____	182
Sharing Virtual Machines with Other Users _____	184
Moving Linked Clones _____	185
<b>Using Disks _____</b>	<b>187</b>
Configuring Hard Disk Storage in a Virtual Machine _____	188
Disk Types: Virtual and Physical _____	188
Disk Files _____	191
Lock Files _____	192
Defragmenting Virtual Disks _____	193
Shrinking Virtual Disks _____	193
Adding Drives to a Virtual Machine _____	197
Adding a New Virtual Disk to a Virtual Machine _____	197
Adding Physical Disks to a Virtual Machine _____	201
Adding DVD or CD Drives to a Virtual Machine _____	204
Adding Floppy Drives to a Virtual Machine _____	206
Connecting a CD-ROM or Floppy Drive to an Image File _____	207
Using VMware Virtual Disk Manager _____	208
Running the VMware Virtual Disk Manager Utility _____	209
Shrinking Virtual Disks with VMware Virtual Disk Manager _____	212
Examples Using the VMware Virtual Disk Manager _____	213
Configuring a Dual-Boot Computer for Use with a Virtual Machine _____	215
Using the Same Operating System in a Virtual Machine and on the Host Computer _____	216
Before You Begin _____	217
Configuring Dual- or Multiple-Boot Systems to Run with VMware Workstation 219	
Setting Up Hardware Profiles in Virtual Machines _____	225
Running a Windows 2000, Windows XP or Windows Server 2003 Virtual Machine from an Existing Multiple-Boot Installation _____	230
Setting Up the SVGA Video Driver for a Windows 95 Guest Operating System Booted from a Raw Disk _____	230
Setting Up the SVGA Video Driver for Use with a Windows 98 Guest Operating System Booted from a Raw Disk _____	232



Do Not Use Windows 2000, Windows XP and Windows Server 2003 Dynamic Disks as Raw Disks _____	234
Configuring Dual- or Multiple-Boot SCSI Systems to Run with VMware Workstation on a Linux Host _____	235
Known Issues and Background Information on Using SCSI Raw Disks ____	238
Installing an Operating System onto a Physical Partition from a Virtual Machine _	241
Configuring a Windows Host _____	242
Configuring a Linux Host _____	244
Legacy Virtual Disks _____	246
Upgrading a Legacy Virtual Machine for New Features of Workstation 5 _	247
Using a Legacy Virtual Machine without Upgrading _____	247
Creating a Legacy Virtual Machine with Workstation 5 _____	247
<b>Preserving the State of a Virtual Machine _____</b>	<b>249</b>
Using Suspend and Resume _____	250
Using Snapshots _____	251
Understanding Snapshots _____	252
Examples of Using Snapshots _____	254
What Is Captured by a Snapshot? _____	255
Taking a Snapshot _____	256
The Snapshot Manager _____	258
Restoring a Snapshot: Revert or Go To? _____	263
Deleting a Snapshot _____	264
Making a Clone from a Snapshot _____	264
Virtual Machine Settings for Snapshots _____	265
Snapshots and Legacy Virtual Machines _____	266
<b>Cloning a Virtual Machine _____</b>	<b>267</b>
Understanding Clones _____	268
Why Make a Clone? _____	268
Full and Linked Clones _____	269
Full Clones and Snapshots of the Parent _____	269
Creating Clones _____	270
The Clone Virtual Machine Wizard _____	270
Working with Clones _____	273
Making a Linked Clone of a Linked Clone _____	273
Making a Full Clone of a Linked Clone _____	273
Network Identity for a Clone _____	273

The Linked Clone Snapshot _____	274
Linked Clones and Access to the Parent Virtual Machine _____	274
<b>Configuring Teams _____</b>	<b>277</b>
Teams Overview _____	278
Creating and Deleting Teams _____	279
Making a New Team _____	279
Opening a Team _____	284
Closing a Team _____	284
Deleting a Team _____	285
Adding and Removing Virtual Machines _____	286
Adding an Existing Virtual Machine to a Team _____	286
Removing a Virtual Machine from a Team _____	286
Cloning and Taking Snapshots of Team Members _____	288
Cloning a Virtual Machine in a Team _____	288
Taking Snapshots of Individual Virtual Machines in a Team _____	288
Starting and Stopping Teams _____	289
Powering On a Team _____	289
Powering Off a Team _____	289
Suspending a Team _____	289
Resuming a Team _____	290
Power Operations for Individual Members of a Team _____	290
Working with Team Networks _____	292
LAN Segment Requirements _____	292
Creating a Team LAN Segment _____	293
Connecting to or Changing a LAN Segment _____	293
Renaming a LAN Segment _____	294
Deleting a LAN Segment _____	294
The Startup Sequence _____	295
Understanding the Start-Up Sequence Delay _____	295
Working with the Team Console View _____	296
Displaying Teams _____	296
The Active Virtual Machine _____	297
Using Full Screen with Teams _____	297
Editing Team Settings _____	298
Connections _____	298
Virtual Machines _____	299
LAN Segments _____	300

Options _____	302
Command Line for Teams _____	303
<b>Configuring a Virtual Network _____</b>	<b>305</b>
Network Basics _____	306
Components of the Virtual Network _____	307
Virtual switch _____	307
Bridge _____	307
Host Virtual Adapter _____	308
NAT Device _____	308
DHCP Server _____	308
Network Adapter _____	308
Common Networking Configurations _____	309
Bridged Networking _____	309
Network Address Translation (NAT) _____	310
Host-Only Networking _____	312
Custom Networking Configurations _____	313
Changing the Networking Configuration _____	316
Adding and Modifying Virtual Network Adapters _____	316
Configuring Bridged Networking Options on a Windows Host _____	318
Enabling, Disabling, Adding and Removing Host Virtual Adapters _____	323
Advanced Networking Topics _____	326
Selecting IP Addresses on a Host-only Network or NAT Configuration _____	327
Avoiding IP Packet Leakage in a Host-Only Network _____	330
Maintaining and Changing the MAC Address of a Virtual Machine _____	332
Controlling Routing Information for a Host-only Network on a Linux Host _____	334
Other Potential Issues with Host-Only Networking on a Linux Host _____	335
Setting Up a Second Bridged Network Interface on a Linux Host _____	336
Setting Up Two Separate Host-Only Networks _____	337
Routing between Two Host-Only Networks _____	340
Using Virtual Ethernet Adapters in Promiscuous Mode on a Linux Host _____	344
Understanding NAT _____	345
Using NAT _____	346
The Host Computer and the NAT Network _____	346
DHCP on the NAT Network _____	346
DNS on the NAT Network _____	347
External Access from the NAT Network _____	347
Advanced NAT Configuration _____	348

Custom NAT and DHCP Configuration on a Windows Host _____	352
Considerations for Using NAT _____	353
Using NAT with NetLogon _____	353
Sample Linux vmnetnat.conf File _____	355
Using Samba with Workstation _____	358
Modifying Your Samba Configuration _____	358
Using a Samba Server for Both Bridged and Host-Only Networks _____	358
Using Samba without Network Access _____	358
<b>Configuring Video and Sound _____</b>	<b>359</b>
Setting Screen Color Depth _____	360
Changing Screen Color Depth on the Host _____	360
Changing Screen Color Depth in the Virtual Machine _____	361
Using Full Screen Mode on a Linux Host _____	362
Experimental Support for Direct3D _____	363
Audience for Direct3D Experimental Support _____	363
Accelerated 3-D Limitations _____	364
Enabling Accelerated 3-D _____	364
Known Issues _____	367
Helping VMware with Experimental Support _____	368
Configuring Sound _____	369
Installing Sound Drivers in Windows 9x and Windows NT Guest Operating Systems _____	369
<b>Connecting Devices _____</b>	<b>371</b>
Using Parallel Ports _____	372
Parallel Ports _____	372
Installation in Guest Operating Systems _____	372
Configuring a Parallel Port on a Linux Host _____	373
Special Notes for the Iomega Zip Drive _____	376
Using Serial Ports _____	377
Using a Serial Port on the Host Computer _____	377
Using a File on the Host Computer _____	378
Connecting an Application on the Host to a Virtual Machine _____	380
Connecting Two Virtual Machines _____	382
Special Configuration Options for Advanced Users _____	385
Examples: Debugging over a Virtual Serial Port _____	387
Keyboard Mapping on a Linux Host _____	389
Quick Answers _____	389

The Longer Story _____	389
V-Scan Code Table _____	393
Using USB Devices in a Virtual Machine _____	397
Notes on USB Support in Version 5 _____	397
Enabling and Disabling the USB Controller _____	397
Connecting USB Devices _____	398
Using USB with a Windows Host _____	398
Replacing USB 2.0 Drivers on a Windows 2000 Host _____	399
Using USB with a Linux Host _____	399
What Has Control over a USB Device? _____	400
Disconnecting USB Devices from a Virtual Machine _____	401
Human Interface Devices _____	401
Connecting to a Generic SCSI Device _____	402
Generic SCSI on a Windows Host Operating System _____	402
Generic SCSI on a Linux Host Operating System _____	404
<b>Performance Tuning _____</b>	<b>407</b>
Configuring and Maintaining the Host Computer _____	408
Location of the Working Directory _____	408
Defragmentation of Disk Drives _____	408
Adequate Free Disk Space _____	409
NIC Interrupt Coalescing _____	409
Configuring VMware Workstation _____	410
General VMware Workstation Options _____	410
VMware Workstation on a Windows Host _____	413
VMware Workstation on a Linux Host _____	415
Monitoring Virtual Machine Performance _____	416
Memory Usage Notes _____	418
Virtual Machine Memory Size _____	418
Memory Use on the Host _____	419
Using More Than 1GB of Memory on a Linux Host _____	422
Improving Performance for Guest Operating Systems _____	424
Windows 95 and Windows 98 Guest Operating System Performance Tips _____	424
Windows 2000, Windows XP and Windows Server 2003 Guest Operating System Performance Tips _____	426
Windows NT Disk Performance on Multiprocessor Hosts _____	427
Linux Guest Operating System Performance Tips _____	427

Disk I/O Performance Tips _____	429
Memory Trimming _____	429
Page Sharing _____	429
<b>Special-Purpose Configuration Options _____</b>	<b>431</b>
Locking Out Interface Features _____	433
Removing a Forgotten Password _____	434
Restricting the User Interface _____	435
Automatically Returning to a Snapshot with a Restricted User Interface _	436
Using Full Screen Switch Mode _____	438
Creating a Virtual Machine for Use in Full Screen Switch Mode _____	438
Moving a Virtual Machine to the User's Computer _____	439
Setting Configuration Options on the User's Computer _____	439
Starting and Stopping Virtual Machines on the User's Computer _____	443
Guest ACPI S1 Sleep _____	446
<b>Glossary _____</b>	<b>447</b>
<b>Index _____</b>	<b>453</b>

# Introduction and System Requirements

---

This chapter discusses the following topics:

- [Product Overview on page 16](#)
- [What's New in Version 5 on page 19](#)
- [Host System Requirements on page 23](#)
- [Virtual Machine Specifications on page 27](#)
- [Supported Guest Operating Systems on page 30](#)
- [Technical Support Resources on page 32](#)

# Product Overview

Thank you for choosing VMware® Workstation, the powerful virtual machine software for enterprise IT professionals.

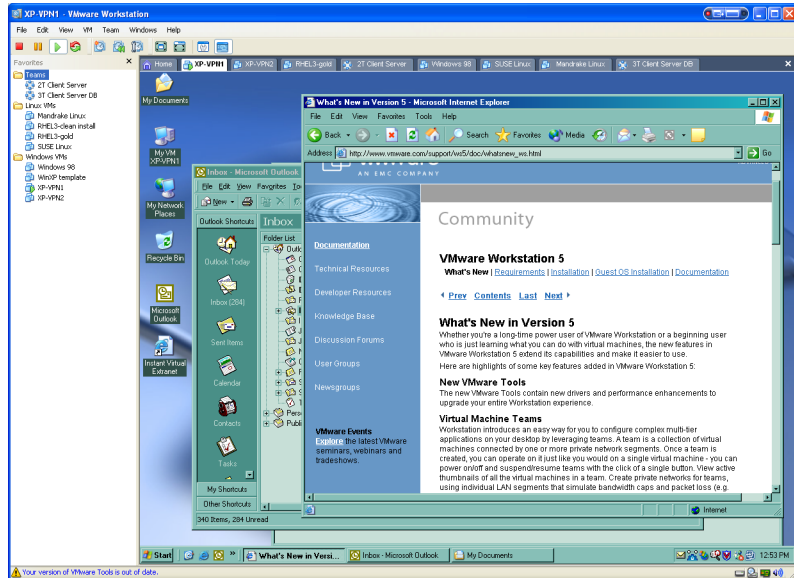

*Run the operating systems and applications you need — all on a single desktop*

## Powerful Virtual Machine Software for the Technical Professional

VMware Workstation is desktop software for developers and IT professionals that allows you to run multiple x86-based desktop and server operating systems simultaneously on a single PC, in fully networked, portable virtual machines — with no rebooting or hard drive partitioning required.

With VMware Workstation, you spend less time procuring and configuring, and more time testing and deploying. Over three million software development, quality assurance, and IT professionals worldwide find VMware Workstation an indispensable tool.

Key benefits include:

- **Run multiple operating systems simultaneously on a single physical machine** — VMware Workstation is desktop software for software developers



and IT professionals that allows a single PC to simultaneously run multiple x86-based operating systems, including Windows, Linux, and NetWare, and their applications in fully networked, portable virtual machines - without rebooting or hard drive partitioning. The result is reduced hardware expenditures and quicker access to different computing environments. Additionally, VMware Workstation lets users avoid platform lock-in and preserve the freedom and flexibility to deploy the most appropriate platforms for their needs.

- **Revolutionize software development and testing** — VMware Workstation streamlines software development and testing by letting users create multiple development and testing environments as virtual machines on a single PC. Developers can create a library of virtual machines and use them to easily develop and test applications on multiple operating systems, or to quickly create and test “real-world” multi-tier configurations or virtual networks. Developers can also use the multiple snapshot capabilities of Workstation to capture and manage point-in-time configurations to facilitate debugging and give a developer the ability to easily revert back to stable configurations should an error occur during testing. VMware Workstation enables developers to reduce configuration and set-up time, and instead focus on development and testing.
- **Enhance productivity of enterprise IT professionals** — VMware Workstation allows system administrators, system engineers, and other enterprise IT professionals to create and test multiple computing environments as virtual machines on a single PC prior to deploying these environments on physical PCs or servers in a production environment. This dramatically reduces hardware costs and the time and risk associated with IT tasks such as deploying new applications, application updates, and operating system patches. Additionally, IT help desk departments can create a virtual library of corporate desktop and server configurations that they can quickly access and manipulate (and then “undo” if necessary), thereby improving their responsiveness and effectiveness when troubleshooting end-user problems.
- **Facilitate team collaboration** — VMware Workstation lets users easily collaborate with their colleagues and share virtual machines. Once a computing environment — OS, associated applications, disk images, memory, etc. — has been turned into a virtual machine, it becomes a set of hardware-independent, encapsulated files that are highly portable and can be shared with any other Workstation user. A virtual machine can be placed on a shared drive where others can quickly access and upload it. Features in Workstation such as linked clones and video capture further facilitate team collaboration.

- **Introduce Virtual Infrastructure to your enterprise** — Virtual machines created in Workstation can be deployed to the other desktop and server virtualization platforms offered by VMware. Introducing VMware Workstation virtualization to the desktop is an ideal first step to transforming your physical IT infrastructure into virtual infrastructure.

## Overview of This Manual

If you're a veteran user of VMware products, take a few minutes to see [What's New in Version 5 on page 19](#), and check out [Upgrading VMware Workstation on page 51](#).

If you're new to VMware Workstation, this is the place to start.

- The first chapters of this manual — through [Running VMware Workstation on page 139](#) — introduce you to some of the things you can do with VMware Workstation and guide you through the key steps for installing the software and putting it to work.
- Later chapters provide in-depth reference material for getting the most out of the sophisticated features of VMware Workstation.

## About the Host and Guest Computers

The terms *host* and *guest* describe your physical and virtual machines:

- The physical computer on which you install the VMware Workstation software is called the host computer, and its operating system is called the host operating system.
- The operating system running inside a virtual machine is called a guest operating system.
- For definitions of these and other special terms, see [Glossary on page 447](#).

# What's New in Version 5

## Multiple Snapshots

VMware Workstation 5 greatly enhances the snapshot functionality available in previous releases of the product by allowing you to take a series of point-in-time, saved-to-disk snapshots of running virtual machines. This makes it easier to capture and switch between multiple configurations and accelerates testing and debugging.

Should a problem arise during testing, you can easily revert to a prior, stable snapshot. The new snapshot manager displays thumbnails of all your snapshots on a single screen, making it easy for you to track and revert to a previously saved snapshot. Also, when reverting to a previously saved snapshot, Workstation creates a new branch automatically, so other snapshots continue to be available. See [Using Snapshots on page 251](#).

## Teams

Teams functionality makes it easier to manage connected virtual machines and simulate “real-world” multitier configurations. A team is your designated group of virtual machines and the private networks that connect them.

Teams allow you to configure power operations, such as powering on and off and suspending or resuming virtual machines, in the exact sequence you desire. You determine network characteristics between the virtual machines in a team, including network bandwidth and packet loss percentages. The console view displays active thumbnails of all the virtual machines in a team, allowing you to easily identify and switch between any of the virtual machines on your team. See [Configuring Teams on page 277](#).

## Clones

Clones simplify the process of copying a virtual machine. Clones facilitate collaborative testing and debugging, and let colleagues share virtual machines more easily. You can duplicate a virtual machine as a linked clone or a full clone.

- Linked clones make it easy to set up a library of baseline virtual machines on a shared drive, to be accessed and shared by you and others, without using unnecessary disk space on local machines.
- A full clone — a complete copy — is also available when you need an identical virtual machine without the need to locate files within the host file system or to tediously install everything required to duplicate an existing guest configuration.

See [Cloning a Virtual Machine on page 267](#).

## **Improved Performance for Virtual Machines Running Concurrently**

Workstation 5 includes significant improvements in memory utilization when virtual machines are used concurrently. This allows you to efficiently run multiple virtual machines with much less total memory.

## **Improved Networking Performance**

Workstation 5 offers optional, enhanced networking performance by leveraging VMware's custom network driver. Once you install the updated VMware Tools, the necessary network drivers integrate seamlessly to offer significantly improved network performance.

## **Improved Suspend/Resume and Snapshot Operations**

Workstation 5 performs significantly faster suspend/resume and snapshot operations, enabling you to spend more time testing and less time waiting for power operations to execute.

## **New Host Operating System Support**

- SUSE Linux Pro 9.2
- SUSE Linux Enterprise Server 9.0
- Mandrake Linux 10
- Windows Server 2003 SP1
- Red Hat Enterprise Linux 4.0

## **New Guest Operating System Support**

- Windows Small Business Server 2000
- Red Hat Linux Advanced Server 3.0
- SUSE Linux Pro 9.2
- SUSE Linux Enterprise Server 9.0
- Mandrake Linux 10
- Novell NetWare 6.5 SP3
- Novell NetWare 5.1 SP8
- Novell Linux Desktop 9
- Sun Java Desktop System
- Windows Server 2003 SP1

- Red Hat Enterprise Linux 4.0 beta
- SUSE Linux Enterprise Server 9 SP1 (experimental support)
- Various other service pack updates and kernel updates

### Improved 64-bit Host Support

- Workstation 5 includes hardware support for AMD Opteron, AMD Athlon 64, and Intel EM64T.
- Software support includes 64-bit host operating systems:
  - Windows XP (experimental support)
  - Red Hat Enterprise Linux 3.0
  - SUSE Linux Enterprise Server 7, 8, 9
  - Windows Server 2003 SP1
  - Red Hat Enterprise Linux 4.0

### Isochronous USB support

Workstation 5 offers support for isochronous USB input devices such as Web cameras and microphones, as well as output devices such as speakers. Use your webcam or work with multitrack audio within your guest operating system.

### Command Line Interface

Workstation 5 offers a new command line interface, enabling you to create scripts to automate certain manual steps. See [Command Line Reference on page 91](#).

### Movie Record and Playback

Workstation 5 offers the ability to record your actions within a virtual machine and save the movie in an AVI format, facilitating team collaboration. Replay the resulting AVI file on any PC equipped with an AVI player. A free Windows player is available for download from the VMware Web site.

Record steps to reproduce defects in a particular configuration, or record configuration steps prior to running an application. Share the movie with colleagues to enable team collaboration. See [Creating a Movie of a Virtual Machine on page 165](#).

### Improved Linux User Interface

Workstation 5 offers a new GTK+, version 2-based user interface on Linux, which provides an improved look and feel, and enhanced usability.

## Easier Upgrades and VMware Tools Installation Improvements

Starting with Workstation 5, on Windows hosts you can automatically install a new release over an existing Workstation release. The installer automatically uninstalls the previous version before installing the new version. Workstation 5 also streamlines VMware Tools installation for Linux virtual machines by allowing users to install VMware Tools without exiting the X session. See [Upgrading VMware Workstation on page 51](#), and [Installing VMware Tools on page 120](#).

## Support for NX bit

Support for the NX bit and XD bit improves security for guest operating systems that take advantage of the feature.

Workstation 5 now supports the no execute and execute disable bit for guest operating systems that can leverage it. Aimed at thwarting malicious buffer overruns, NX and XD allow properly written applications to designate memory space as nonexecutable, so that no code can be executed from that memory space.

## Experimental Support for Direct3D

Workstation 5 includes experimental support for Direct3D video acceleration. This feature is not fully functional. For information on configuring a virtual machine for 3-D support, see [Experimental Support for Direct3D on page 363](#)

## Experimental Support for Guest ACPI S1 Sleep

Workstation 5 VMware Tools provide experimental support for guest operating systems that enable ACPI S1 sleep. (This feature requires you to have the latest VMware Tools installed.) For detailed configuration options, see [Guest ACPI S1 Sleep on page 446](#).

## VMware Virtual Machine Importer

This standalone utility allows you to convert your Microsoft® virtual machines — from either Virtual PC or Microsoft Virtual Server — into a VMware virtual machine. The VMware virtual machine is compatible with Workstation 4 or 5, completely independent of the previous format, ready to use with all the enhanced VMware Workstation functionality. The original file remains intact. See [Converting a VirtualPC Virtual Machine on page 113](#).

# Host System Requirements

What do you need to get the most out of VMware Workstation 5? Take the following list of requirements as a starting point. Like physical computers, the virtual machines running under VMware Workstation generally perform better if they have faster processors and more memory.

## PC Hardware

- Standard x86-compatible personal computer
- 400 MHz or faster CPU minimum (500 MHz recommended)

Compatible processors include

- Intel®: Celeron®, Pentium® II, Pentium III, Pentium 4, Pentium M (including computers with Centrino™ mobile technology), Xeon™ (including “Prestonia”)
- AMD™: Athlon™, Athlon MP, Athlon XP, Duron™, Opteron™
- Experimental support for AMD Sempron™

For additional information, including notes on processors that are not compatible, see the VMware knowledge base at [www.vmware.com/support/kb/enduser/std\\_adp.php?p\\_faqid=967](http://www.vmware.com/support/kb/enduser/std_adp.php?p_faqid=967).

- Multiprocessor systems supported
- 64-bit processor support for AMD64 Opteron, Athlon 64 and Intel IA-32e CPU (including “Nocona”)

## Memory

- 128 MB minimum (256 MB recommended)

You must have enough memory to run the host operating system, plus the memory required for each guest operating system and for applications on the host and guest. See your guest operating system and application documentation for their memory requirements.

## Display

- 16-bit or 32-bit display adapter recommended

## Disk Drives

Guest operating systems can reside on physical disk partitions or in virtual disk files.

### Hard Disk

- IDE and SCSI hard drives supported, up to 950GB capacity
- At least 1GB free disk space recommended for each guest operating system and the application software used with it; if you use a default setup, the actual disk space needs are approximately the same as those for installing and running the guest operating system and applications on a physical computer.
- **For Installation** — 80MB (Linux) or 150MB (Windows) free disk space required for basic installation. You can delete the installer afterwards to reclaim 56 – 60MB.

### Optical CD-ROM/DVD-ROM Drive

- IDE and SCSI optical drives supported
- CD-ROM and DVD-ROM drives supported
- ISO disk image files supported

### Local Area Networking (Optional)

- Any Ethernet controller supported by the host operating system
- Non-Ethernet networks supported using built-in network address translation (NAT) or using a combination of host-only networking plus routing software on the host operating system

### Host Operating System

VMware Workstation is available for both Windows and Linux host operating systems.

#### Windows Host Operating Systems (32-bit)

- Windows Server 2003 Web Edition, Windows Server 2003 Standard Edition, Windows Server 2003 Enterprise Edition, Service Pack 1 (listed versions also supported with no service pack)
- Windows XP Professional and Windows XP Home Edition Service Pack 1 or 2 (listed versions also supported with no service pack)
- Windows 2000 Professional Service Pack 3 or 4, Windows 2000 Server Service Pack 3 or 4, Windows 2000 Advanced Server Service Pack 3 or 4 (listed versions also supported with no service pack)



### Windows Host Operating Systems (64-bit)

- Windows Server 2003 Service Pack 1 64-bit edition
- Experimental support for prerelease Windows XP 64-bit edition

Internet Explorer 4.0 or higher is required for the Windows online help system.

### Linux Host Operating Systems

Supported distributions and kernels are listed below. VMware Workstation may not run on systems that do not meet these requirements.

**Note:** As newer Linux kernels and distributions are released, VMware modifies and tests its products for stability and reliability on those host platforms. We make every effort to add support for new kernels and distributions in a timely manner, but until a kernel or distribution is added to the list below, its use with our products is not supported. Look for newer prebuilt modules in the download area of our Web site. Go to [www.vmware.com/download/](http://www.vmware.com/download/).

- Mandrake Linux 10 — stock 2.6.3-7
- Mandrake Linux 9.0 — stock 2.4.19
- Red Hat Enterprise Linux AS/ES/WS 4.0 — stock 2.6.9-5, 64-bit
- Red Hat Enterprise Linux AS/ES/WS 3.0 — stock 2.4.21, update 2.4.21-15.EL, 64-bit
- Red Hat Enterprise Linux 2.1 — stock 2.4.9-e3
- Red Hat Linux Advanced Server 2.1 — stock 2.4.9-e3
- Red Hat Linux 9.0 — stock 2.4.20-8, upgrade 2.4.20-20.9
- Red Hat Linux 8.0 — stock 2.4.18
- Red Hat Linux 7.3 — stock 2.4.18
- Red Hat Linux 7.2 — stock 2.4.7-10, upgrade 2.4.9-7, upgrade 2.4.9-13, upgrade 2.4.9-21, upgrade 2.4.9-31
- SUSE Linux 9.2 — stock 9.2-2.6.8-24.11
- SUSE Linux 9.1 — stock 2.6.4-52
- SUSE Linux 9.0 — stock 2.4.21-99
- SUSE Linux Enterprise Server 9.0 — 32-bit, 64-bit, SP1 (listed versions also supported with no service pack)
- SUSE Linux Enterprise Server 8 — stock 2.4.19, 64-bit
- SUSE Linux 8.2 — stock 2.4.20

- SUSE Linux 8.1 — stock 2.4.19
- SUSE Linux 8.0 — stock 2.4.18
- SUSE Linux Enterprise Server 7 — stock 2.4.7 and patch 2
- SUSE Linux 7.3 — stock 2.4.10

Platforms not listed above are not supported.

A Web browser is required for the Help system.

# Virtual Machine Specifications

Each virtual machine created with VMware Workstation 5 provides a platform that includes the following devices that your guest operating system can see.

## Processor

- Same processor as that on host computer
  - Note:** A 64-bit processor runs in 32-bit legacy mode inside the virtual machine.
- Single processor per virtual machine on symmetric multiprocessor systems

## Chip Set

- Intel 440BX-based motherboard
- NS338 SIO
- 82093AA IOAPIC

## BIOS

- PhoenixBIOS™ 4.0 Release 6 with VESA BIOS

## Memory

- Up to 3.6GB, depending on host memory
- Maximum of 4GB total available for all virtual machines

## Graphics

- VGA and SVGA support

## IDE Drives

- Up to four devices — disks, CD-ROM or DVD-ROM (DVD drives can be used to read data DVD-ROM discs; DVD video is not supported)
- Hard disks can be virtual disks or physical disks
- IDE virtual disks up to 950GB
- CD-ROM can be a physical device or an ISO image file

## SCSI Devices

- Up to seven devices
- SCSI virtual disks up to 950GB
- Hard disks can be virtual disks or physical disks
- Generic SCSI support allows devices to be used without need for drivers in the host operating system. Works with scanners, CD-ROM, DVD-ROM, tape drives and other SCSI devices
- LSI Logic® LSI53C10xx Ultra320 SCSI I/O controller
- Mylex® (BusLogic) BT-958 compatible host bus adapter (requires add-on driver from VMware for Windows XP and Windows Server 2003)

## Floppy Drives

- Up to two 1.44MB floppy devices
- Physical drives or floppy image files

## Serial (COM) Ports

- Up to four serial (COM) ports
- Output to serial ports, Windows or Linux files, or named pipes

## Parallel (LPT) Ports

- Up to two bidirectional parallel (LPT) ports
- Output to parallel ports or host operating system files

## USB ports

- Two-port USB 1.1 UHCI controller
- Supports most devices including USB printers, scanners, PDAs, hard disk drives, memory card readers and digital cameras, as well as streaming devices such as webcams, speakers, and microphones.

## Keyboard

- 104-key Windows 95/98 enhanced

## Mouse and Drawing Tablets

- PS/2 mouse
- Serial tablets supported

## Ethernet Card

- Up to three virtual Ethernet cards
- AMD PCnet-PCI II compatible

## Sound

- Sound output and input
- Emulates Creative Labs Sound Blaster AudioPCI (MIDI input, game controllers and joysticks are not supported, except for USB devices)

## Virtual Networking

- Support for nine or more virtual Ethernet switches, depending on the host operating system. Three switches are configured by default for bridged, host-only, and NAT networking.
- Support for most Ethernet-based protocols, including TCP/IP, NetBEUI, Microsoft Networking, Samba, Novell Netware, and Network File System.
- Built-in NAT supports client software using TCP/IP, FTP, DNS, HTTP, and Telnet, including VPN support for PPTP over NAT.

## Supported Guest Operating Systems

The operating systems listed here have been tested in VMware Workstation 5 virtual machines and are officially supported. For notes on installing the most common guest operating systems, see the *VMware Guest Operating System Installation Guide*, available from the VMware Web site or from the Help menu.

Operating systems that are not listed are not supported for use in a VMware Workstation virtual machine. For the most recent list of supported guest operating systems, see the following page from the online Workstation 5 documentation on the VMware Web site, [www.vmware.com/support/ws/doc/intro\\_supguest\\_ws.html](http://www.vmware.com/support/ws/doc/intro_supguest_ws.html).

### Microsoft Windows 32-bit

- Experimental support for Windows, code-named Longhorn, beta
- Windows Server 2003 Web Edition, Standard Edition, Enterprise Edition, Small Business Server 2003; Service Pack 1 (listed versions also supported with no service pack)
- Windows XP Professional and Home Edition Service Pack 1 or 2 (listed versions also supported with no service pack)
- Windows 2000 Professional and Server Service Pack 1, 2, 3 or 4 (listed versions also supported with no service pack), Windows 2000 Advanced Server Service Pack 3 or 4
- Windows NT® Workstation and Server 4.0 Service Pack 6a required, Windows NT 4.0 Terminal Server Edition Service Pack 6 required
- Windows Me
- Windows 98 (including all Customer Service Packs) and Windows 98 SE
- Windows 95 (including Service Pack 1 and all OSR releases)
- Windows for Workgroups 3.11
- Windows 3.1

### Microsoft MS-DOS

- MS-DOS 6.x

## Linux

- Mandrake Linux 8.2, 9.0, 9.2, 10
- Red Hat Linux 7.0, 7.1, 7.2, 7.3, 8.0, 9.0
- Red Hat Enterprise Linux AS/ES/WS 4.0 (32-bit)
- Red Hat Enterprise Linux AS/ES/WS 2.1, 3.0
- Red Hat Enterprise Linux Advanced Server 2.1
- SUSE Linux 7.3, 8.0, 8.1, 8.2, 9.0, 9.1, 9.2.
- SUSE Linux Enterprise Server 7, 7 patch 2, 8, 9, 9 SP1
- Turbolinux 7.0, Enterprise Server 8, Workstation 8
- Novell Linux Desktop 9
- Sun Java Desktop System (JDS) 2

## Novell Netware

- Netware Server 5.1 SP8, 6.0 SP4, 6.5 SP3

## FreeBSD

- FreeBSD 4.0, 4.1, 4.2, 4.3, 4.4, 4.5, 4.6.2, 4.8, 5.0

**Note:** If you use SCSI virtual disks larger than 2GB with FreeBSD 4.0–4.3, there are known problems, and the guest operating system does not boot. To work around this issue, see the *VMware Guest Operating System Installation Guide*, available from the VMware Web site or from the Help menu.

## Sun Solaris

- Experimental support for Solaris x86 Platform Edition 9, 10 beta

# Technical Support Resources

## Documentation on the Web

You can find full documentation for VMware Workstation, including the latest updates to the manual, on the VMware Web site, at [www.vmware.com/support/pubs/ws\\_pubs.htm](http://www.vmware.com/support/pubs/ws_pubs.htm)

## VMware Knowledge Base

You can find troubleshooting notes and tips for advanced users in the knowledge base on the VMware Web site at [www.vmware.com/kb](http://www.vmware.com/kb).

## VMware User Community

The VMware user community includes VMware-sponsored discussion forums and newsgroups.

### Community Discussion Forums

The VMware Community is a set of moderated discussion forums hosted on the VMware Web site, open to all VMware users. In the forums, you can share your experiences in using VMware products, raise technical questions or issues, and benefit from the expertise and advice of other VMware users. The VMware community forum is at [www.vmware.com/community](http://www.vmware.com/community).

### Newsgroups

The VMware newsgroups are primarily forums for users to help each other. You are encouraged to read and post issues, work-arounds, and fixes. While VMware personnel may read and post to the newsgroups, they are not a channel for official support. The VMware NNTP news server is at [news.vmware.com](http://news.vmware.com).

For more information on the forums and newsgroups, see [www.vmware.com/vcommunity/newsgroups.html](http://www.vmware.com/vcommunity/newsgroups.html).

## Reporting Problems

If you have problems while running VMware Workstation, please report them to the VMware support team.

These guidelines describe the information we need from you to diagnose problems.

If a virtual machine exits abnormally or crashes, please run the support script to collect the appropriate log files and system information. Follow the steps below that apply to your host computer.



### Windows Host

1. Open a command prompt.
2. Change to the VMware Workstation program directory.  

```
C:
cd \Program Files\VMware\VMware Workstation
```

If you did not install the program in the default directory, use the appropriate drive letter and path in the `cd` command above.
3. Run the support script.  

```
cscript vm-support.vbs
```
4. After the script runs, it displays the name of the directory where it has stored its output. Use a file compression utility such as WinZip or PKZIP to zip that directory, and include the zip file with your support request.

### Linux Host

1. Open a terminal.
2. Run the support script as the user who is running the virtual machine.  

```
vm-support
```

If you are not running the script as root, the script displays messages indicating that it cannot collect some information. This is normal. If the VMware support team needs that information, a support representative will ask you to run the script again as root.
3. The script creates a compressed `.tgz` file in the current directory. Include that output file with your support request.

If you are reporting a problem you encountered while installing VMware Workstation, it is also helpful to have your installation log file.

On a Windows host, the file is `VMInst.log`. It is saved in your temp folder. On a Windows 2000, Windows XP or Windows Server 2003 host, the default location is `C:\Documents and Settings\<username>\Local Settings\Temp`.

You can use the command `cd %temp%` to locate the `Local Settings` folder, which is hidden by default. To see its contents, open **My Computer**, go to **Tools > Folder Options**, click the **View** tab and select **Show Hidden Files and Folders**.

Be sure to register your serial number. You may then report your problems by submitting a support request at [www.vmware.com/requestsupport](http://www.vmware.com/requestsupport).

## Where to Go Next

- [Installing VMware Workstation on page 35](#)
- [Upgrading VMware Workstation on page 51](#)

# Installing VMware Workstation

---

This chapter discusses how to install VMware Workstation on your Linux or Windows host system:

- [Selecting Your Host System on page 36](#)
    - [Upgrading from Previous Versions on page 36](#)
  - [Installing VMware Workstation 5 on a Windows Host on page 37](#)
    - [Installing Workstation on a Windows Host on page 38](#)
    - [Installing VMware Workstation Silently on page 41](#)
    - [Uninstalling VMware Workstation 5 on a Windows Host on page 43](#)
  - [Installing VMware Workstation 5 on a Linux Host on page 44](#)
    - [Before Installing on a Linux Host on page 45](#)
    - [Installing Workstation on a Linux Host on page 45](#)
    - [Configuring with vmware-config.pl on page 48](#)
    - [Web Browser Required on page 48](#)
    - [Uninstalling VMware Workstation 5 on a Linux Host on page 49](#)
-

## Selecting Your Host System

VMware Workstation is available for both Windows and Linux host computers. The installation files for both host platforms are included on the same CD-ROM.

Your serial number allows you to use VMware Workstation only on the host operating system for which you licensed the software. If you have a serial number for a Windows host, you cannot run the software on a Linux host, and vice versa.

To use VMware Workstation on a different host operating system — for example, to use it on a Linux host if you have licensed the software for a Windows host — purchase a license on the VMware Web site. You may also get an evaluation license at no charge for a 30-day evaluation of the software. For more information, see [www.vmware.com/download/](http://www.vmware.com/download/).

- To install on a supported Windows host computer, see [Installing VMware Workstation 5 on a Windows Host on page 37](#).
- To install on a Linux host computer, see [Installing VMware Workstation 5 on a Linux Host on page 44](#).

### Upgrading from Previous Versions

If you are upgrading from a previous version of VMware Workstation, read [Upgrading VMware Workstation on page 51](#) before you begin.

### Workstation Cannot Share a Host with Other VMware Products

You cannot have VMware Workstation installed on the same host machine with another VMware product, such as VMware GSX Server, VMware ACE, or the VMware Virtual Machine Console. The only VMware product that can share a host machine with Workstation is the VMware VirtualCenter client software. If you plan to install VMware Workstation on a host machine that already contains another VMware product, you must uninstall that product first.

# Installing VMware Workstation 5 on a Windows Host

Getting started with VMware Workstation is simple. The key steps are

1. Install the VMware Workstation software as described in [Installing Workstation on a Windows Host on page 38](#).
2. Start VMware Workstation and enter your serial number.  
  
You need to do this only once — during the installation process when prompted or through **Help > Enter Serial Number**.  
  
If you don't already have a serial number from a previous installation, the installer prompts you for the serial number during installation. If you choose not to enter the serial number during installation, you can enter it later by going to **Help > Enter Serial Number**.
3. Create a virtual machine using the New Virtual Machine Wizard. See [Creating a New Virtual Machine on page 101](#).
4. Install a guest operating system in the new virtual machine. You need the installation media (CD-ROM or floppy disks) for your guest operating system. See [Installing a Guest Operating System and VMware Tools on page 117](#).
5. Install the VMware Tools package in your virtual machine for enhanced performance. See [Installing VMware Tools on page 120](#).
6. Start using your virtual machine.

Before you begin, be sure you have

- A computer and host operating system that meet the system requirements for running VMware Workstation. See [Host System Requirements on page 23](#).
- The VMware Workstation installation software. If you bought the packaged distribution of VMware Workstation, the installation software is on the CD in your package. If you bought the electronic distribution, the installation software is in the file you downloaded.
- Your VMware Workstation serial number. The serial number is included in the VMware Workstation package or in the email message confirming your electronic distribution order.
- The installation CD or disks for your guest operating system.

## Installing Workstation on a Windows Host

1. Log on to your Microsoft Windows host as the Administrator user or as a user who is a member of the Windows Administrators group.

**Note:** To install Workstation on a Windows XP or Windows Server 2003 host computer, you must log on as local administrator (that is, not be logged on to the domain, unless your domain account is also a local administrator).

Although an administrator must install Workstation on Windows XP or Windows Server 2003, a normal user — without administrative privileges — can run the program after it is installed.

**Note:** Keep in mind that you need one license for each user.

2. If you are installing from a CD, from the **Start** menu, choose **Run** and enter `D:\setup.exe`, where `D:` is the drive letter for your CD-ROM drive.

If you are installing from a downloaded file, from the **Start** menu, choose **Run**, browse to the directory where you saved the downloaded installer file and run the installer. (The filename is similar to `VMwareWorkstation-  
<xxxx>.exe`, where `<xxxx>` is a series of numbers representing the version and build numbers.)

3. Click **Next** to dismiss the Welcome dialog box.

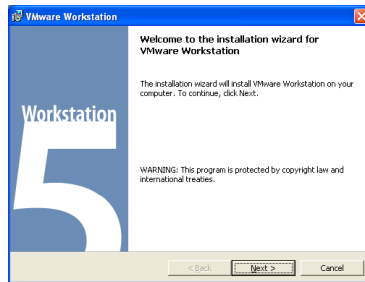

- Acknowledge the end user license agreement (EULA).

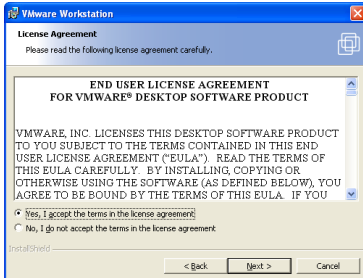

Select the **Yes, I accept the terms in the license agreement** option, then click **Next**.

- Choose the directory in which to install VMware Workstation.

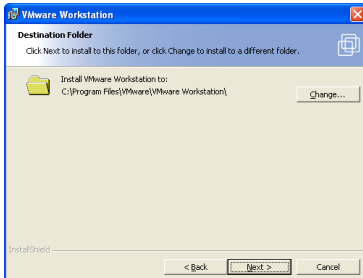

To install it in a directory other than the default, click **Change** and browse to your directory of choice. If the directory does not exist, the installer creates it for you. Click **Next**.

**Caution:** Do not install VMware Workstation on a network drive.

**Note:** Windows and the Microsoft Installer limit the length of a path to a folder on a local drive to 255 characters. For a path to a folder on a mapped or shared drive, the limit is 240 characters. If the path to the VMware Workstation program folder exceeds this limit, an error message appears. You must select or enter a shorter path.

6. Select the shortcuts that you want the installer to create.

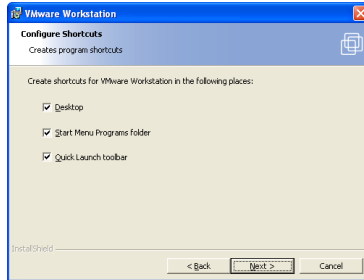

Choices include Desktop, Start menu, and Quick Launch toolbar. Deselect any shortcuts you do not want the installer to create.

7. If the installer detects that the Windows CD-ROM autorun feature is enabled, you see a message that gives you the option to disable this feature. Disabling autorun prevents undesirable interactions with the virtual machines you install on this system.
8. The installer has gathered the necessary information and is ready to begin installing the software.

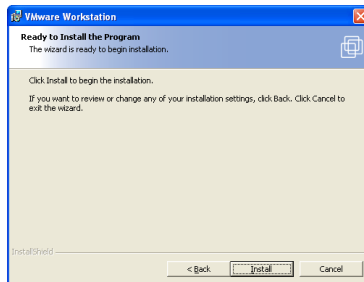

If you want to change any settings or information you provided, now is the time to make those changes. Click **Back** until you reach the dialog box containing the information you want to change.

If you do not need to make any changes, click **Install**. The installer begins copying files to your computer.



- (Optional) Enter your name, company name and serial number, then click **Next**.

Your serial number is on the registration card in your package. The user and company information you enter here is then made available in the About box (**Help > About VMware Workstation**).

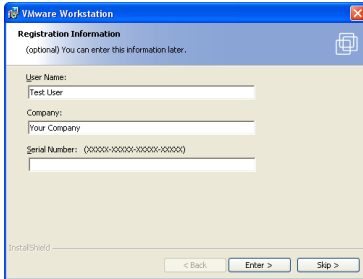

**Note:** If you skip this step, you must enter your serial number later, before you can power on a virtual machine.

- Click **Finish**. The VMware Workstation software is installed.

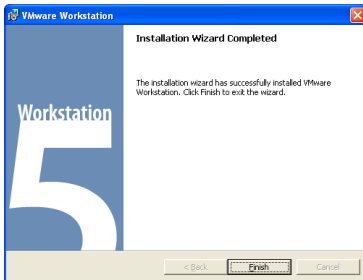

- Some installations may require that you reboot your PC. Reboot now to allow VMware Workstation to complete the installation correctly.

## Installing VMware Workstation Silently

If you are installing VMware Workstation on a number of Windows host computers — in a corporate environment, for example — you may want to use the silent installation features of the Microsoft Windows Installer.

Before installing VMware Workstation silently, you must ensure that the host computer has version 2.0 or higher of the MSI runtime engine. This version of the installer is available in versions of Windows beginning with Windows XP and is available separately from Microsoft.

The following steps outline the procedures for a silent install. For additional details on using the Microsoft Windows Installer, see the Microsoft Web site.

1. Silently extract the administrative installation image from the VMware Workstation installer:

```
setup.exe /a /s /v"/qn TARGETDIR=<InstallTempPath>"
```

`setup.exe` is the name of the installer on the CD distribution. If you are using a downloaded installer, the filename is similar to `VMwareWorkstation-  
<xxxx>.exe`, where `<xxxx>` is a series of numbers representing the version and build numbers.

`<InstallTempPath>` is the full path to the folder where you want to store the administrative installation image.

2. Run a silent installation using `msiexec` and the administrative installation image you extracted in the previous step:

```
msiexec -i "<InstallTempPath>\VMware Workstation.msi"  
[INSTALLDIR="<PathToProgramDirectory>"] ADDLOCAL=ALL  
[REMOVE=<featurename,featurename>] /qn
```

Enter the command on one line. If you want to install VMware Workstation in a location other than the default, change the path that follows `INSTALLDIR=` to specify the desired location.

You may use the optional `REMOVE=` property to skip installation of certain features. The `REMOVE=` property can take one or more of the following values:

Value	Description
Authd	The VMware authorization service
Network	Networking components including the virtual bridge and the host adapters for host only networking and NAT networking; do not remove if you want to use NAT or DHCP
DHCP	The virtual DHCP server
NAT	The virtual NAT device

If you specify more than one value, use a comma to separate the values. For example, `REMOVE=Authd,NAT`.

**Note:** If you specify `REMOVE=Network`, the installer skips installation of certain networking components, including NAT and DHCP. There is no need to specify `DHCP` or `NAT` separately.

You may customize the installation further by adding any of the following installation properties to the command using the format `PROPERTY="value"`. A value of 1 means true; a value of 0 means false. If you use the serial number property, enter the serial number, complete with hyphens (`xxxxxx-xxxxxx-xxxxxx-xxxxxx`).

Property	Effect of the Property	Default
DESKTOP_SHORTCUT	Installs a shortcut on the desktop	1
DISABLE_AUTORUN	Disables CD autorun on the host	1
REMOVE_LICENSE	(Uninstall only) Removes all stored licenses at uninstall	0
SERIALNUMBER	Automatically enters the serial number	

### Uninstalling VMware Workstation 5 on a Windows Host

To uninstall VMware Workstation 5, use the Add/Remove Programs control panel. Select the entry for VMware Workstation, then click **Remove**. Follow the on-screen instructions.

# Installing VMware Workstation 5 on a Linux Host

Getting started with VMware Workstation is simple. The key steps are

1. Install the VMware Workstation software as described in [Installing Workstation on a Linux Host on page 45](#).
2. Start VMware Workstation
3. Enter your serial number.

You need to do this only once. If you don't already have a serial number configured from a previous installation, you are prompted for the serial number when you start Workstation. To enter the serial number choose

**Help > Enter Serial Number.**

**Note:** You can install Workstation without a serial number. However you cannot power on a virtual machine without entering a serial number.

4. Create a virtual machine using the New Virtual Machine Wizard. See [Creating a New Virtual Machine on page 101](#).
5. Install a guest operating system in the new virtual machine. You need the installation media (CD-ROM or floppy disks) for your guest operating system. See [Installing a Guest Operating System and VMware Tools on page 117](#).
6. Install the VMware Tools package in your virtual machine for enhanced performance. See [Installing VMware Tools on page 120](#).
7. Start using your virtual machine.

## Before Installing on a Linux Host

Before you begin, be sure you have

- A computer and host operating system that meet the system requirements for running VMware Workstation. See [Host System Requirements on page 23](#).
- The VMware Workstation installation software. If you bought the packaged distribution of VMware Workstation, the installation software is on the CD in your package. If you bought the electronic distribution, the installation software is in the file you downloaded.
- Your VMware Workstation serial number. The serial number is included in the VMware Workstation package or in the email message confirming your electronic distribution order.
- The installation CD or disks for your guest operating system.

Check the following notes and make any necessary adjustments to the configuration of your host operating system.

- **vmware-distrib** — If you have a previous tar installation, delete the previous `vmware-distrib` directory before installing from a tar file again. The default location of this directory is `/tmp/vmware-distrib`
- **Clock** — The real-time clock function must be compiled into your Linux kernel.
- **Parallel port** — VMware Workstation for Linux requires that the parallel port PC-style hardware option (`CONFIG_PARPORT_PC`) be built and loaded as a kernel module (that is, it must be set to `m` when the kernel is compiled).

## Installing Workstation on a Linux Host

**Note:** The steps below describe an installation from a CD-ROM disc. If you downloaded the software, the steps are the same except that you start from the directory where you saved the installer file you downloaded, not from the `Linux` directory on the CD.

1. Log on to your Linux host with the user name you plan to use when running VMware Workstation.
2. In a terminal window, become root so you can perform the initial installation steps.  
`su -`
3. Mount the VMware Workstation CD-ROM.
4. Change to the `Linux` directory on the CD.

5. Continue installation with the appropriate section for your desired installer:
  - [Using the tar Installer](#)
  - [Using the RPM Installer](#)

### Using the tar Installer

**Note:** You may skip the steps for copying and unpacking the archive and install directly from the `vmware-distrib` directory on the CD.

- a. Copy the tar archive to a temporary directory on your hard drive — for example, `/tmp`.

```
cp VMware-<xxxx>.tar.gz /tmp
```

- b. Change to the directory to which you copied the file.

```
cd /tmp
```

- c. Unpack the archive.

```
tar xzf VMware-<xxxx>.tar.gz
```

- d. Change to the installation directory.

```
cd vmware-distrib
```

- e. Run the installation program.

```
./vmware-install.pl
```

- f. Accept the default directories for the binary files, library files, manual files, documentation files and init script.

- g. Answer Yes when prompted to run `vmware-config.pl`.

This completes the tar archive installation instructions. Skip the RPM installer instructions and continue with step 6.

### Using the RPM Installer

- a. Run RPM specifying the installation file.

```
rpm -Uhv VMware-<xxxx>.rpm
```

`VMware-<xxxx>.rpm` is the installation file on the CDROM. In place of `<xxxx>` the filename contains numbers that correspond to the version and build.

- b. Run the configuration program from the command line.

```
vmware-config.pl
```

6. Press Enter to read the end user license agreement (EULA). You may page through it faster by pressing the space bar. If the `Do you accept` prompt doesn't appear, press Q to get to the next prompt.
7. The remaining prompts are worded in such a way that, in most cases, the default response is appropriate.

**Note:** If you do not enable host-only networking when you install Workstation, you cannot allow a virtual machine to use both bridged and host-only networking.

8. The configuration program displays a message saying the configuration completed successfully. If it does not display this message, run the configuration program again.
9. When done, exit from the root account.  
`exit`

Install VMware Tools after you install a guest operating system. See [Installing VMware Tools on page 120](#).

## Configuring with `vmware-config.pl`

Use `vmware-config.pl` to configure your installation of VMware Workstation.

**Note:** If you run the RPM installer, you need to run this program separately from the command line. If you install from the tar archive, the installer offers to launch the configuration program for you. Answer Yes when you see the prompt.

### Required Configuration Changes

Configuration with `vmware-config.pl` is required in the following circumstances:

- When you install VMware Workstation the first time.
- When you upgrade your version of Workstation.
- When you upgrade your host operating system kernel. (It is not necessary to reinstall VMware Workstation after you upgrade your kernel.)
- To reconfigure the networking options for VMware Workstation — for example, to add or remove host-only networking.

### Location of `vmware-config.pl`

The installer places `vmware-config.pl` in `/usr/bin`. If `/usr/bin` is not in your default path, run the program with the following command:

```
/usr/bin/vmware-config.pl
```

### Web Browser Required

To use the VMware Workstation Help system, you must have a Web browser installed on your host computer.



## Uninstalling VMware Workstation 5 on a Linux Host

### Uninstalling an RPM Installation of Workstation

If you used the RPM installer to install VMware Workstation, remove the software from your system by running

```
rpm -e VMwareWorkstation*
```

**Note:** The asterisk symbol \* is a wildcard for the build number.

### Uninstalling a tar Installation of Workstation

If you used the tar installer to install VMware Workstation, remove the software from your system by running

```
vmware-uninstall.pl
```

## Where to Go Next

- [Learning VMware Workstation Basics on page 61](#)
- [Creating a New Virtual Machine on page 101](#)
- [Running VMware Workstation on page 139](#)

# CHAPTER 3

## Upgrading VMware Workstation

---

This chapter discusses how to upgrade VMware Workstation 3 or 4 on your Linux or Windows host system, and how to use existing virtual machines under VMware Workstation 5:

- [Preparing for the Upgrade on page 52](#)
- [Upgrading on a Windows Host on page 55](#)
- [Upgrading on a Linux Host on page 56](#)
- [Using Workstation 4 Virtual Machines in Workstation 5 on page 57](#)

# Preparing for the Upgrade

## Before You Install VMware Workstation 5

There are a few steps you should take — while your previous version of VMware Workstation is still on your computer and before you install VMware Workstation 5 — to ensure the best possible upgrade experience.

### Resume and Shut Down Suspended Virtual Machines

If you plan to use virtual machines created in an earlier version of VMware Workstation 5, be sure they have been shut down completely before you remove the release you used to create them.

If the virtual machine is suspended, resume it in the earlier release, shut down the guest operating system, then power off the virtual machine.

**Note:** If you attempt to resume a virtual machine that was suspended under a different VMware product or a different version of VMware Workstation, a dialog box gives you the choice of discarding or keeping the file that stores the suspended state. To recover the suspended state, you must click **Keep**, then resume the virtual machine under the correct VMware product. If you click **Discard**, you can power on normally, but the suspended state is lost.

### Remove Snapshots

If the virtual machine you are upgrading has a snapshot, remove the snapshot before upgrading.

### Make Sure All Disks Are in the Same Mode (Workstation 3 Only)

For upgrades from VMware Workstation 3 to Workstation 5:

- If you have an existing virtual machine with one or more virtual disks and all the disks use persistent or undoable mode, upgrading is straightforward.
- If you have an existing virtual machine with one or more virtual disks and all the disks use nonpersistent mode, you need to take a few special steps when you upgrade VMware Tools. See [www.vmware.com/info?id=44](http://www.vmware.com/info?id=44)
- If you plan to use an existing virtual machine that has disks in undoable mode, you must commit or discard any changes to the virtual disks before you remove the Workstation 3 software that you used to create them.
- Resume or power on the virtual machine in the earlier release, shut down the guest operating system, power off the virtual machine and either commit or discard changes to the disk in undoable mode when prompted.
- If the disks are in persistent or nonpersistent mode, be sure the virtual machine is completely shut down. If it is suspended, resume it, shut down the guest operating system and power off the virtual machine.
- If you have an existing virtual machine that has multiple virtual disks and the disks are in multiple modes, the simplest approach to upgrading is to convert all the disks to persistent mode. Resume or power on the virtual machine in the earlier release, shut down the guest operating system, power off the virtual machine and either commit or discard changes to any undoable mode disks when prompted. Then open the configuration editor and change all disks to persistent mode.

If you need to preserve special functionality that requires disks in multiple modes, review the information at [www.vmware.com/info?id=40](http://www.vmware.com/info?id=40) before you upgrade.

### Back Up Virtual Machines

As a precaution, back up all the files in your virtual machine directories — including the `.vmdk` or `.disk`, `.vmtx` or `.cfg` and `nvram` files — for any existing virtual machines you plan to migrate to VMware Workstation 5. Depending on your upgrade path, you may not be able to run your virtual machines under both VMware Workstation 5 and your previous version of VMware Workstation.

**Workstation 2 to 5** — Upgrading Workstation 2 virtual machines requires that you first upgrade to Workstation 3 or 4. Direct upgrades from a Workstation 2 virtual machine are not supported in Workstation 5.

**Workstation 3 to 5** — Virtual machines created under Workstation 3 must be upgraded before they can run under Workstation 5. Once they are upgraded, they cannot be run under Workstation 3.

**Workstation 4 to 5** — Virtual machines created under Workstation 4 — or updated to Workstation 4 — offer two options.

- You may update the virtual machine for full compatibility with Workstation 5. However, a virtual machine upgraded to Workstation 5 can no longer be used under Workstation 4.
- You may choose not to update the virtual machine. In that case, you can run the virtual machine under both Workstation 4 and Workstation 5, but you do not enable new features provided by Workstation 5. For example, you cannot take multiple snapshots.

### Removing Version 3 or 4 to Install Version 5

There is a key precaution you should take when you remove VMware Workstation 3 or 4 — or an earlier version of VMware Workstation 5 — to install VMware Workstation 5.

- Leave the existing license in place.

VMware Workstation installation procedures for your host may require that you run an uninstaller to remove a previous version.

- On a Windows host, the uninstaller may ask if it should remove licenses from your registry. *Do not allow the uninstaller to remove the licenses.* You can safely keep licenses for multiple VMware products on the computer at the same time.
- On a Linux host, the license remains in place. You do not need to take any special action. You may safely leave the license where it is.

The actual upgrade installation depends on your host operating system:

- [Upgrading on a Windows Host on page 55](#)
- [Upgrading on a Linux Host on page 56](#)

## Upgrading on a Windows Host

- You may upgrade from Workstation 4 to version 5 using the VMware Workstation 5 upgrade product.
- To upgrade from version 3 to version 5, you must have the full VMware Workstation 5 product.

### Upgrading from Version 4 or an Earlier Version 5 Release

1. Launch the Workstation 5 installer from your download directory or CDROM.
2. Reboot your computer if you are prompted to do so.
3. Allow the installer to complete the installation.

### Upgrading from Version 3 to Version 5

1. Uninstall the Workstation version now installed on your computer. For details, see [Removing Version 3 on page 55](#).

**Note:** The uninstaller may offer to remove licenses from your registry. Do not remove the licenses.

2. Reboot your computer.
3. Install version 5.

**Note:** When you are upgrading with an upgrade serial number, the installer checks for the presence of a version 4 license on the computer. If it finds no version 4 license, it prompts you to enter your version 4 serial number.

4. Reboot your computer.

### Removing Version 3

1. Launch the VMware Workstation uninstaller.  
**Start > Programs > VMware > VMware Workstation Uninstallation**
2. Click **Yes**.
3. Follow the on-screen instructions. You need to keep your existing license in the Windows registry.

After you reboot, follow the instructions in [Installing VMware Workstation 5 on a Windows Host on page 37](#).

## Upgrading on a Linux Host

You may upgrade from version 4 to version 5 using the upgrade version of VMware Workstation 5. To upgrade from version 3 to version 5, you must have the full version of VMware Workstation 5. Upgrades from earlier versions of VMware Workstation are not supported.

**Note:** When you are upgrading with the upgrade product, the installer checks for the presence of a license on the computer. If it finds no license, it prompts you to enter your previous version serial number.

**Note:** Starting with Workstation 5, Samba is no longer automatically configured when you run `vmware-config.pl`.

### The tar Upgrade Process

If you used the tar installer to install version 3 or 4 — or an earlier release of version 5 — and you plan to use the tar installer for version 5, you do not need to take any special steps to uninstall the older version. Just follow the installation instructions [Installing VMware Workstation 5 on a Linux Host on page 44](#).

### The RPM Upgrade Process

Take the following steps to upgrade to version 5 if you used the RPM installer to install Workstation 3 or 4 — or an earlier release of version 5.

If you are currently using version 3.0, you need to uninstall the RPM package of prebuilt modules that was installed with 3.0 before you uninstall the 3.0 software. You do not need to take this step if you are currently using version 3.1.

1. Uninstall any previous version as root:

If you are running version 3.0, uninstall the prebuilt modules as root, then uninstall VMware Workstation by running

```
rpm -e VMwareWorkstationKernelModules
rpm -e VMwareWorkstation
```

If you are running version 3.1, 3.2 or 4, or an earlier release of version 5, uninstall it as root by running

```
rpm -e VMwareWorkstation*
```

**Note:** The asterisk symbol `*` is a wild card to account for the version number of Workstation that was previously installed.

2. Install version 5 following the instructions in [Installing VMware Workstation 5 on a Linux Host on page 44](#).



# Using Workstation 4 Virtual Machines in Workstation 5

There are, broadly speaking, three approaches you can take when you set up virtual machines. Choose one of these approaches.

- [Create Everything New from the Start on page 57](#)
- [Use a Legacy Virtual Machine without Upgrading on page 57](#)
- [Use a Legacy Virtual Machine with Upgrade on page 58](#)

Only the latter two apply to virtual machines created under previous versions of VMware Workstation.

## **Create Everything New from the Start**

Use the New Virtual Machine Wizard to set up a new virtual machine and install a guest operating system in the virtual machine as described in [Creating a New Virtual Machine on page 101](#). If you set up your virtual machines in this way, you are using the latest technology and enjoy the performance benefits of the newest features.

## **Use a Legacy Virtual Machine without Upgrading**

A legacy virtual machine is a virtual machine created in Workstation 4.x, GSX Server 3.x and ESX Server 2.x. You can use such a virtual machine in Workstation 5.

- Upgrade VMware Tools to the new version following the instructions for your guest operating system in [Installing VMware Tools on page 120](#). You should not remove the older version of VMware Tools before installing the new version.
- A VMware Workstation 4 virtual machine set up in this way should run without problems. However, you will not have the benefits of certain new features, including multiple snapshots, streaming USB devices, and performance improvements.

## Use a Legacy Virtual Machine with Upgrade

If you upgrade an existing virtual machine from Workstation 4.x, GSX Server 3.x or ESX Server 2.x, you gain access to new features and enjoy the performance benefits of the new virtual machine, including:

- Multiple snapshots
- Streaming USB input devices
- Increased network bandwidth, optimized disk and memory cache

### Notes on Upgrading a Virtual Machine

- If you previously installed the version of VMware Tools included in Workstation 5, you must reinstall after the virtual machine upgrade and choose the "Repair" option.
- If you are upgrading a virtual machine that runs from a physical disk, rather than a virtual disk, you may see the following error message while VMware Workstation is upgrading the virtual machine: "Unable to upgrade <drivename>. One of the supplied parameters is invalid." You may safely click **OK** to continue the upgrade process.
- When you update a Windows XP or Windows Server 2003 virtual machine, the Microsoft product activation feature requires you to reactivate the guest operating system.
- **The virtual machine upgrade is irreversible:** Virtual machines upgraded to Workstation 5 are incompatible with VMware Workstation 3, Workstation 4.x, GSX Server 3.x and ESX Server 2.x. Make backup copies of your virtual disks before starting the upgrade.

**Procedure to Upgrade Virtual Machines**

1. Shut down the guest operating system and power off the virtual machine,
2. Choose **VM > Upgrade Virtual Machine**.

A dialog box appears, warning that the upgrade process cannot be reversed.

3. Click **Yes** to continue, then follow the on-screen directions.
4. Power on the virtual machine in Workstation 5.
5. Upgrade VMware Tools to the new version

Refer to [Installing VMware Tools on page 120](#). Do not remove the older version of VMware Tools before installing the new version.

**Note:** If you are upgrading a virtual machine that runs from a physical disk, rather than a virtual disk, you may safely ignore the message: “Unable to upgrade <drivename>. One of the supplied parameters is invalid.” Click **OK** to continue the upgrade.

## Where to Go Next

- [Learning VMware Workstation Basics on page 61](#)
- [Creating a New Virtual Machine on page 101](#)
- [Running VMware Workstation on page 139](#)

# 4

CHAPTER

## Learning VMware Workstation Basics

---

This chapter discusses launching the VMware Workstation program, and introduces the VMware Workstation window.

- [Launching VMware Workstation on page 62](#)
- [Overview of the VMware Workstation Window on page 64](#)
- [Checking for Product Updates on page 75](#)
- [Setting Preferences for VMware Workstation on page 76](#)
- [Virtual Machine Settings on page 83](#)
- [Command Line Reference on page 91](#)
- [Keyboard Shortcuts on page 95](#)
- [What Files Make Up a Virtual Machine? on page 96](#)

The illustrations in these sections show a Windows XP guest operating system. Some commands used in the illustrations are different from those used in other guest operating systems.

---

## Launching VMware Workstation

The method of starting the VMware Workstation application depends on your host operating system.

- [Launching VMware Workstation on a Windows Host](#)
- [Launching VMware Workstation on a Linux Host](#)

### Launching VMware Workstation on a Windows Host

Launch VMware Workstation by double-clicking the shortcut on your desktop or launch the program from the Start menu (Start > Programs > VMware > VMware Workstation).



The VMware Workstation window opens.

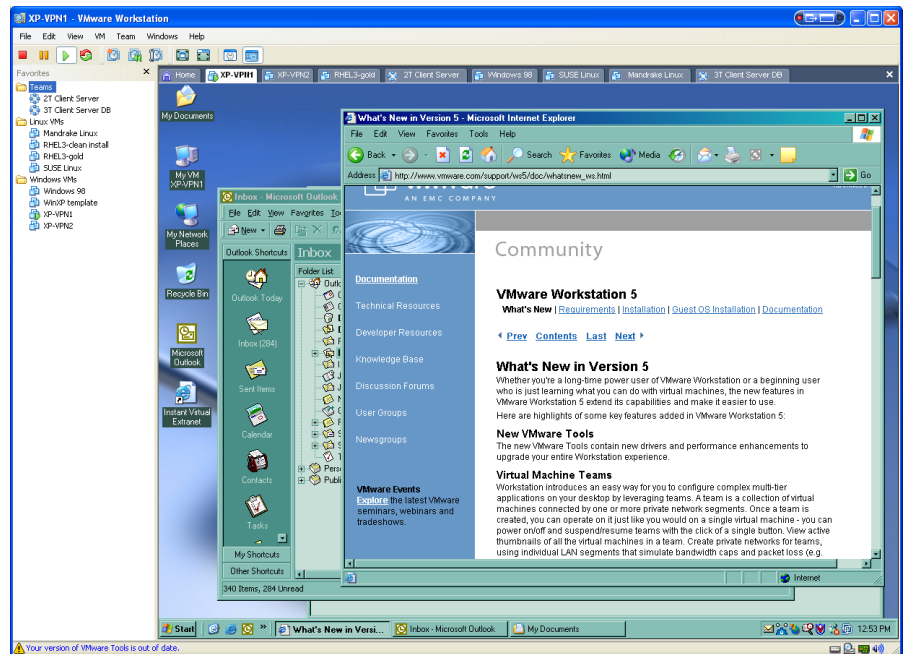

The Workstation window: Windows host

## Launching VMware Workstation on a Linux Host

1. Open a terminal window.
2. Type `vmware &` and press Enter.  
The VMware Workstation window opens.

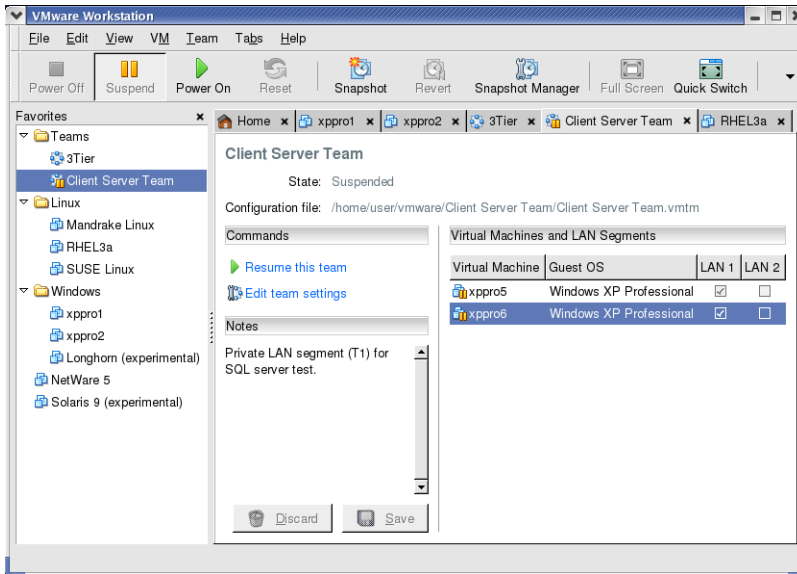

The Workstation window: Linux host

# Overview of the VMware Workstation Window

A VMware Workstation virtual machine is like a separate computer that runs in a window on your physical computer. However, VMware Workstation displays more than the screen of a physical computer. From the Workstation window, you can access and run your virtual machines and teams, and switch easily from one to another.

This section shows you how to navigate and use the VMware Workstation window, and how to set up a list of favorites — virtual machines and teams that you use often and want to access quickly

- [The Home Page, Summary View, and Console View on page 66](#)
- [The Toolbar on page 69](#)
- [The Favorites List on page 71](#)

To open the Workstation application, see [Launching VMware Workstation on page 62](#).

To create a new virtual machine and install a guest operating system, see [Creating a New Virtual Machine on page 101](#).

## One Window or Many — Your Choice

In VMware Workstation 5, you can open multiple virtual machines in the same Workstation window. Or you can launch multiple instances of VMware Workstation. You can even run multiple instances of VMware Workstation and have more than one virtual machine in each window. Just be sure you have enough memory and processor power to handle the number of virtual machines you want to run.



The VMware Workstation window is divided into three main sections.

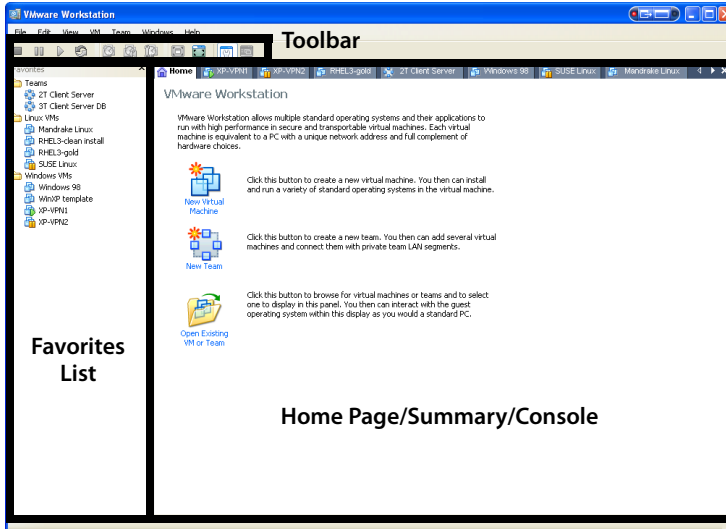

*Workstation window sections: toolbar, favorites list, and home page/summary/console*

- **The Home Page, Summary View, and Console View** — Appearing on the right, this main part of the window is the display screen where your virtual machines display information.
- **The Toolbar** — These buttons along the top allow you to act on your virtual machines, offering one-click options for power, suspend, snapshot, screen and summary/console display.
- **The Favorites List** — Appearing on the left, this area lets you bookmark your virtual machines and teams of virtual machines for quick access.

## The Home Page, Summary View, and Console View

VMware Workstation displays three views in the main part of the window:

- [Displaying the Home Page](#)
- [Displaying the Summary View](#)
- [Displaying the Console View](#)

### Displaying the Home Page

In the Workstation window, select the **Home** tab to display the Workstation home page. Use the icons on the home page to start creating a new virtual machine or open an existing virtual machine.

To close the home page, click the X to the right of the tabs on a Windows host or the X on the tab on a Linux host. To display the home page again, choose **View > Go to Home Tab**.

### Displaying the Summary View

When you select a tab for a powered-off virtual machine or team, Workstation displays a summary of the configuration information about that item. Workstation also displays a summary for a suspended virtual machine or team.

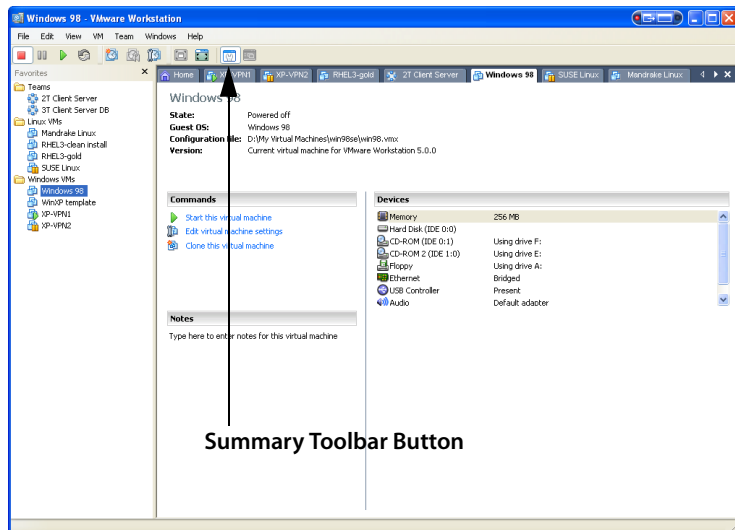

*Summary view for a virtual machine (Windows host)*

You can examine settings in the Summary view at any time by clicking the Summary toolbar button. However, some settings can be changed only when the virtual

machine or team is powered off (not running or suspended). See [Adding, Configuring, and Removing Devices in a Virtual Machine on page 164](#) or [Editing Team Settings on page 298](#) for information about editing settings.

**Note:** Summary tabs are displayed only for virtual machines that are currently open. To open a virtual machine that is not displayed, choose **File > Open > Virtual Machine**, navigate to the virtual machine's `.vmx` file, and select **Open**. The summary/console tab remains visible as long as the virtual machine remains open.

**The Status Bar** — In the Summary view, messages from VMware Workstation appear in the status bar, at the bottom left of the summary window.



*The status bar*

For example, the status bar displays an alert if the version of VMware Tools in a virtual machine does not match your version of Workstation.

The status bar displays an icon for each removable device. On a Windows host, you can right-click an icon to disconnect it or edit its configuration.

## Displaying the Console View

The console view for an active virtual machine is like the monitor screen of a hardware PC.

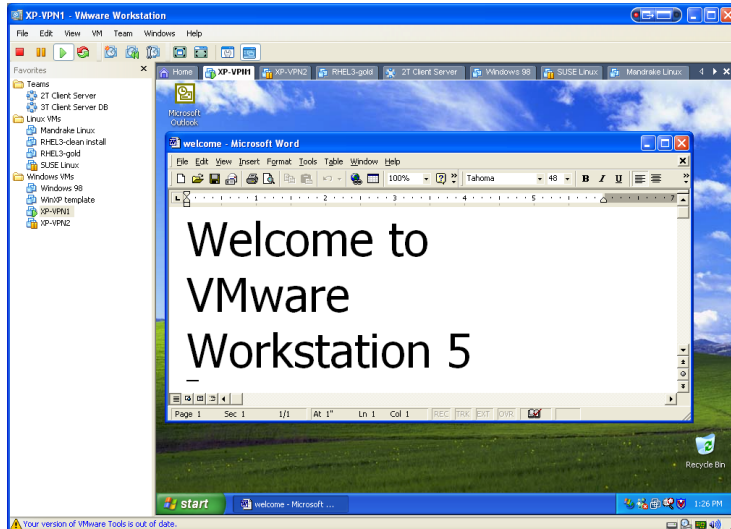

*Windows host console window*

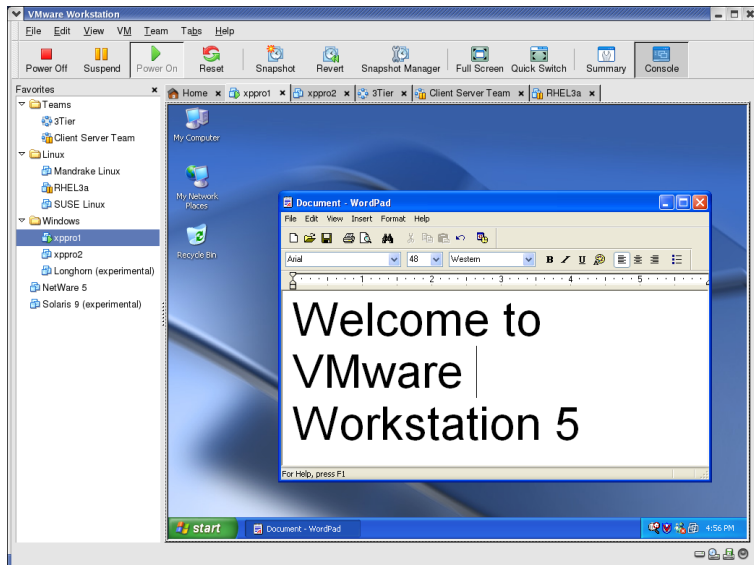

*Linux host console window*

When a virtual machine is active, the name of the virtual machine — or the name of the team it is on, if any — is always displayed in a tab at the top of the console. To switch from the active virtual machine or team, click the tab of another virtual machine or team. You can use the console tabs in the windowed view, and also in the quick switch view.



*Tabs make it easy to switch among active virtual machines (Windows host)*

## Displaying Multiple Virtual Machines at the Same Time

If you want to view more than one virtual machine when they are not all on the same team, you can open multiple Workstation windows and launch one or more virtual machines in each Workstation window. Alternately you can use a team to coordinate and use multiple virtual machines within a single console window. See [Displaying Teams on page 296](#) for a complete description of the console view for teams.

## The Toolbar

The toolbar, at the top of the Workstation window, contains buttons you can click to power your virtual machines on and off, change the Workstation display, and manage snapshots. The following sections describe the toolbar buttons.

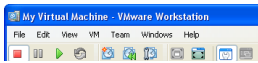

*Toolbar for virtual machine (Windows host)*

**Caution:** When a team is active, clicking the power on, power off, suspend, resume, or reset button affects all the virtual machines on that team.

### Power Off

This button turns off the active virtual machine or team like the power button on a hardware PC. You can configure Workstation for a soft power off (called shut down) or a hard power off, (called power off). See [Shutting Down a Virtual Machine on page 144](#), or [Starting and Stopping Teams on page 289](#) for a description of this feature.

### Suspend

This button stops a virtual machine or team in a manner that allows you to resume your work later, as if you never left. You may be familiar with the concept of suspending your work on a laptop. See [Using Suspend and Resume on page 250](#) for a description of this feature.

### Power On or Resume

This button powers on a selected virtual machine or team that is powered off, or resumes a virtual machine or team that is suspended.

- Power on — See [Starting a Virtual Machine on page 141](#), or [Starting and Stopping Teams on page 289](#) for a description.
- Resume — See [Using Suspend and Resume on page 250](#) for a description.

### Reset

This button resets a virtual machine or team, like the reset button on a physical PC.

### Snapshot

This button allows you to save the state of a virtual machine in the same manner you might save a word-processing document. You can come back later to that state if you make a mistake with the Revert button. See [Using Snapshots on page 251](#) for a description of this feature.

### Revert

This button allows you to return a virtual machine to the parent state, a state previously preserved by taking a snapshot. See [Using Snapshots on page 251](#) for a description of this feature.

### Manage Snapshots

This button opens the Snapshot Manager, where you can view the virtual machine's existing snapshots, revert to a snapshot, take a new snapshot, and make a clone from a snapshot. For more on the Snapshot Manager, see [The Snapshot Manager Window on page 260](#).

### Full Screen

This button enlarges the virtual machine display to cover the entire host monitor. The virtual machine no longer appears in a window.

**Note:** Workstation menus and toolbar are not visible in full screen mode. Press Ctrl-Alt to restore the Workstation window.

**Note:** If you are unable to enter fullscreen mode when the guest's display mode is smaller than the host's display mode, try adding the following line to the virtual machine's configuration (`.vmx`) file:

```
mks.maxRefreshRate=1000
```

See [What Files Make Up a Virtual Machine?](#) for a description of this file.

### Quick Switch

This button enlarges the Workstation console to cover the entire host monitor. Console tabs are visible, allowing you to switch between your virtual machines and teams with a single click.

**Note:** Workstation menus and toolbar are not visible in quick switch mode. Move your cursor to the top of the screen to show the menu and toolbar momentarily.

### Summary

This button displays the summary view. See [Displaying the Summary View on page 66](#) for a description of this view.

### Console

This button displays the console view. See [Displaying the Console View on page 68](#) for a description of this view.

### The Favorites List

This section describes the following topics:

- [Overview of the Favorites List on page 72](#)
- [Adding an Item to the Favorites List on page 72](#)
- [Adding the Active Virtual Machine to the Favorites List on page 73](#)
- [Removing an Item from the Favorites List on page 73](#)
- [Removing the Active Virtual Machine from the Favorites List on page 73](#)
- [Changing the Name of a Favorite List Item on page 73](#)
- [Organizing Favorites into Folders on page 73](#)
- [Hiding and Displaying the Favorites List on page 74](#)

## Overview of the Favorites List

The Favorites list gives you a convenient way to organize and access frequently-used items.

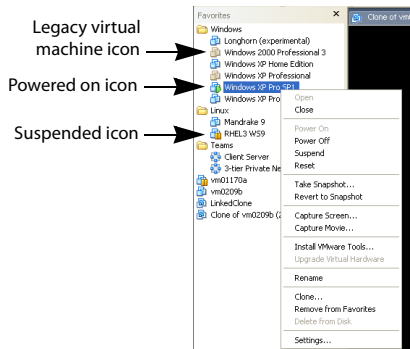

*The Favorites list*

- **Fast access** — Like bookmarks in a web browser, the Favorites list helps you quickly access frequently-used items. With your virtual machines and teams on the Favorites list, you can open them without browsing the host file system. Also like browser bookmarks, Favorites list icons can be organized in folders, added, rearranged, or deleted — without affecting the items they open.
- **Status** — The Favorites list displays the status of virtual machines and teams by using different icons. A Favorites list icon indicates whether the team or virtual machine is powered off, powered on, or suspended. The icon also indicates whether the virtual machine is a legacy virtual machine that needs to be upgraded to use all the features of the current Workstation version.
- **Right-click commands** — You can right-click on a Favorites icon to display a menu of commands you can use for that virtual machine or team.

## Adding an Item to the Favorites List

To add a virtual machine or team entry to the Favorites list

1. Open the virtual machine or team that you want to add.  
Choose (**File > Open**) and browse to the location of the virtual machine (.v`mx` file) or team (.v`mtm` file) you want as a favorite.
2. Choose **File > Add to Favorites**.

The virtual machine or team name appears in the Favorites list.



### Adding the Active Virtual Machine to the Favorites List

To add the currently open virtual machine, Choose **File > Add to Favorites**.

The virtual machine name appears in the Favorites list.

### Removing an Item from the Favorites List

You can remove the name of a virtual machine from the Favorites list at any time. Removing the name from the list does not affect the virtual machine's files or operation. You can add the virtual machine to the list again at any time.

To remove a name from the Favorites list, take these steps.

1. Click a name in the list to select it.
2. Choose **File > Remove from Favorites**.

The virtual machine name is removed from the Favorites list.

### Removing the Active Virtual Machine from the Favorites List

To remove the currently open virtual machine from the Favorites list:

Choose **File > Remove from Favorites**.

The virtual machine is removed from the Favorites list.

### Changing the Name of a Favorite List Item

You can rename the Favorites list entry for a virtual machine or team.

To rename a Favorite list entry:

1. Right-click the Favorite you want to rename.
2. Select **Rename** from the pop-up menu.
3. Type the new name for the Favorite and press Enter.

**Note:** This change is for display only, and does not rename the virtual machine files on the host.

### Organizing Favorites into Folders

You can arrange your virtual machines and teams in folders.

To create a folder:

1. Right-click in the Favorites list.
2. Select **New > Folder** from the pop-up menu.
3. Type a name for the folder and press enter.
4. Drag and drop your virtual machine or team favorites into the new folder as desired.

### **Hiding and Displaying the Favorites List**

To toggle the display of the Favorites list on or off:

1. Choose **View > Favorites**.

If the Favorites list was visible, it becomes hidden. If it was hidden, now it is visible.

## Checking for Product Updates

VMware Workstation checks automatically to see if updates for the product are available. By default, it checks once a week, at the time you launch Workstation. You can change the interval for the automatic checks, and you can check manually at any time by choosing **Help > Check for Updates on the Web**.

To have VMware Workstation check for updates automatically.

1. Choose **Edit > Preferences > Workspace**.
2. On the **Check for software Updates** drop-down menu, set the interval.

The choices are: Never, Daily, Weekly, or Monthly.

**Note:** This check works only if the host computer is connected to the Internet.

# Setting Preferences for VMware Workstation

The Preferences dialog box allows you to change a number of settings that apply to VMware Workstation itself, no matter what virtual machine you are running.

**Note:** On a Linux host, you must be logged in as root to save global preference changes.

The settings on the Workspace, Input and Hot Keys tabs apply to the user currently logged on to the host computer. They do not affect settings made by any other user on the computer. The settings on the Display, Memory and Lockout tabs apply no matter what virtual machine is running or who is logged on to the host computer. The settings on the Priority tab apply to all virtual machines for the user currently logged on to the host computer. They do not affect settings made by any other user on the computer.

To make changes to these settings, choose **Edit > Preferences**.

## Workspace

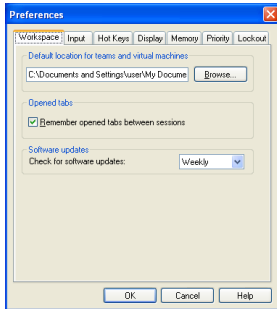

The **Workspace** tab lets you change the directory in which newly created virtual machines are stored. The directory Workstation uses by default is displayed under **Default location for teams and virtual machines**. To set a different directory, type in the path or click **Browse** to navigate to the directory you want to use. Workstation creates a directory for each new virtual machine under the directory you specify here.

If you select **Remember opened tabs between sessions**, you see a tab for each opened virtual machine or team in the console window the next time you start Workstation. A virtual machine or team is considered opened if both of the following conditions are true:

- The virtual machine or team was left open.
- The virtual machine or team was powered on and off or powered on and suspended.

Use the **Check for software updates** drop-down menu to determine how often VMware Workstation checks to see if new versions of the product are available. You can choose daily, weekly or monthly automatic checks or choose **Never** to turn off automatic checking. You can check manually at any time by choosing **Help > Check for Updates on the Web**.

## Input

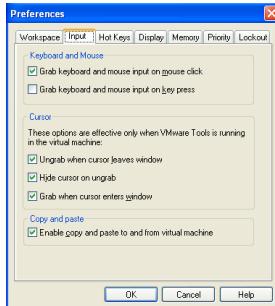

The **Input** tab lets you adjust the way that the virtual machine captures control of keyboard and mouse.

**Note:** The option **Grab when cursor enters window** allows you to move the mouse pointer back into the virtual machine window easily if you have been working in the virtual machine, then temporarily moved the mouse pointer outside the virtual machine window. The mouse pointer is grabbed only when VMware Workstation has focus (is the active application). Also, if you release the mouse pointer by pressing a hot-key combination — Ctrl-Alt by default — you must click inside the virtual machine window to make VMware Workstation grab the mouse pointer again.

## Hot Keys

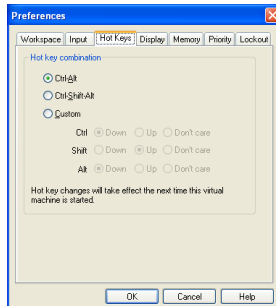

The **Hot Key** tab lets you change the key combination that determines whether certain combinations of keys are passed to the guest operating system or intercepted by VMware Workstation.

**Note:** Because Ctrl-Alt is the key combination used to tell VMware Workstation to release (ungrab) mouse and keyboard input, combinations that include Ctrl-Alt are not passed to the guest operating system. If you need to use such a combination —

for example, use Ctrl-Alt-<Fkey> to switch between Linux workspaces in a virtual machine — press Ctrl-Alt-Space, release Space without releasing Ctrl and Alt, then press the third key of the key combination you want to send to the guest.

Using this dialog box, you can also construct your own custom hot-key combination.

## Display

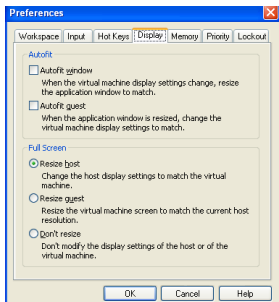

The **Display** tab lets you adjust the manner in which the console and the host display accommodate a different guest operating system display resolution.

### Autofit

Use Autofit preferences to control how the console window behaves when Autofit is active.

- Select **Autofit window** to have Workstation change the console window size to match the guest operating system screen resolution. This is the same as choosing **View > Autofit Window**.
- Select **Autofit guest** to have Workstation change the guest operating system display resolution to match the console window size. This is the same as choosing **View > Autofit Guest**.

**Note:** Selecting **Autofit guest** also activates **Autofit window**.

## Full Screen

Use **Full Screen** preferences to configure how the host and guest display settings interact when you enter full screen mode on the host.

- Select **Resize host** to change the host display settings to match the display settings of the guest while the guest is in full screen mode.
- Select **Resize guest** to change the guest's display settings to match the host display settings while the guest is in full screen mode.
- Select **Don't resize** to have both host and guest retain their own display settings while the guest is in full screen mode.

## Memory

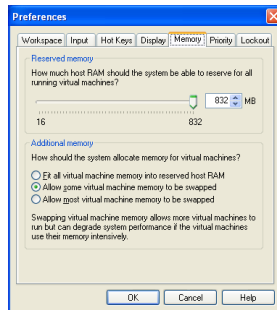

The **Memory** tab lets you adjust the amount of physical RAM that can be used by all running virtual machines. It also lets you adjust how much virtual machine memory may be swapped to disk, allowing you to run more or larger virtual machines if you are willing to accept slower performance.

For details on adjusting memory settings in VMware Workstation, see [Memory Usage Notes on page 418](#).



## Priority



### Process Priority (Windows Hosts Only)

Process priority determines the precedence that the Windows process scheduler gives to your virtual machines when mouse and keyboard input are going to a particular virtual machine and when input is not going to that virtual machine.

You can adjust these settings to improve overall system performance based on the relative priority of work you are doing in various virtual machines and on the host computer.

To change the settings for a particular virtual machine, and override the global settings, open the virtual machine you want to adjust, choose **VM > Settings**, click the **Options** tab, select **Advanced**, then use the drop-down lists under **Process priorities** to make the setting you want for that virtual machine.

There is no corresponding setting on a Linux host.

### Snapshots

If you select **Take and restore snapshots in the background**, you can continue using your virtual machine even when Workstation is taking or restoring a snapshot.

Enabling background snapshots for a host with slow hard disks may affect performance. If you experience significant performance problems when taking or restoring snapshots, turn off this option.

Workstation supports only one background snapshot process at a time for a virtual machine. If you take or restore a second snapshot before a previous snapshot operation completes for the same virtual machine, Workstation displays a progress bar until the previous snapshot operation completes. Then the second snapshot operation continues in the background.

A virtual machine that is powered on does not recognize any change to this check box until you restart that virtual machine.

## Lockout (Windows Hosts Only)

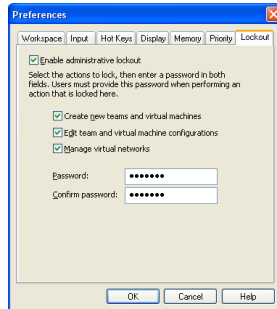

The **Lockout** tab lets you restrict who can create new virtual machines, edit virtual machine configurations and change networking settings. For details, see [Locking Out Interface Features on page 433](#).

There are no corresponding settings on a Linux host.

# Virtual Machine Settings

VMware Workstation configures a newly created virtual machine based on the guest operating system you select in the New Virtual Machine Wizard (**File > New > Virtual Machine**). Use the virtual machine settings editor (**VM > Settings**) if you want to change any configuration options from the wizard defaults.

## Hardware

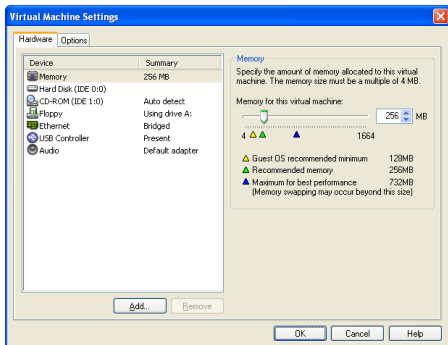

Use the **Hardware** tab to add, remove, and configure virtual devices for the virtual machine.

- Memory — See [Memory Usage Notes on page 418](#).
- Virtual Disk — See [Adding a New Virtual Disk to a Virtual Machine on page 197](#).
- CD-ROM — See [Adding DVD or CD Drives to a Virtual Machine on page 204](#).
- Floppy — See [Adding Floppy Drives to a Virtual Machine on page 206](#).
- Ethernet — See [Adding and Modifying Virtual Network Adapters on page 316](#).
- Serial Port — See [Using Serial Ports on page 377](#).
- Parallel Port — See [Using Parallel Ports on page 372](#).
- USB Controller — See [Using USB Devices in a Virtual Machine on page 397](#).
- Sound Adapter — See [Configuring Sound on page 369](#).
- Generic SCSI Device — See [Steps to a New Virtual Machine on page 102](#).
- Mouse (Linux host only) — See [Human Interface Devices on page 401](#).

## Options

The **Options** tab lets you adjust characteristics of the selected virtual machine.

### General

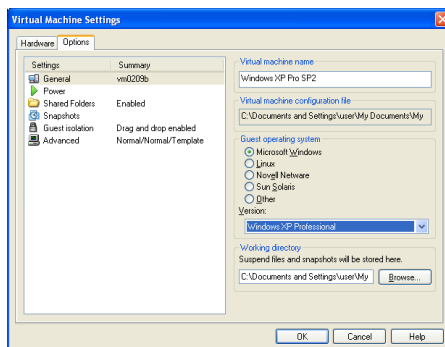

**Virtual Machine Name** — Use this setting to change the virtual machine name. Type a new name in the field and click **OK**.

This field affects the virtual machine name only as it appears in the console tab and Favorites list. Changing the virtual machine name here does not change the names of the virtual machine files.

**Virtual Machine Configuration File** (Windows only) — This read-only field displays the path to the file that contains configuration information for the selected virtual machine.

**Guest Operating System** — Workstation optimizes the virtual machine for the operating system you choose in this field.

**Version** — Use this field to change the setting for the guest operating system version in the virtual machine's configuration file. This setting does not actually change the guest operating system itself.

When you set the guest operating system type in the New Virtual Machine Wizard, Workstation chooses configuration defaults based on the guest type you choose. Changing the guest type in this field simply changes the guest type setting in the configuration file.

The Version field is useful when you are upgrading the guest operating system installed in the virtual machine, and you want to change the guest operating system version.

**Working Directory** — The working directory is where Workstation stores suspended state (.vms.s), snapshot (.vmsn) and redo log files. By default, this is the same directory the virtual machine files are stored in.

## Power

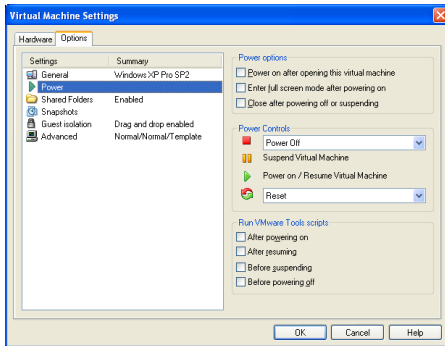

### Power options



- **Power on after opening this virtual machine** — Select this option to power on the selected virtual machine automatically when Workstation launches. With this option selected, you do not have an opportunity to change the virtual machine's configuration before it starts, since the virtual machine powers on immediately.
- **Enter full screen mode after powering on** — Select this option to enter full screen mode automatically after powering on the selected virtual machine.
- **Close after powering off or suspending** — Select this option to close the selected virtual machine automatically after you power it off or suspend it. Closing a virtual machine removes the tab for that machine from the main window in quick switch mode.

## Power Controls

**Note:** Settings in Power Controls apply only to the active virtual machine.

-  You can configure this button to turn off a virtual machine or team in two ways. Select **Power Off** if you want this button to work the way a power switch works on a power supply. The virtual machine is abruptly powered off, with no consideration for work in progress. Select **Shut Down Guest** if you want this button to send a shut down signal to the guest operating system. An operating system that recognizes this signal shuts down gracefully.

**Note:** Not all guest operating systems respond to a shut down signal from this button. If your operating system does not respond to a shut down signal, shut down from within the operating system, as you would with a physical machine.

-  The suspend button is not configurable.
-  The power on or resume button is not configurable.
-  You can configure this button to reset a virtual machine or restart a guest operating system. Select **Reset** if you want this button to work as a reset switch. The virtual machine is abruptly reset, with no consideration for work in progress. Select **Restart Guest** if you want this button to send a restart signal to the guest operating system. An operating system that recognizes this signal shuts down gracefully and restarts.

**Note:** Not all guest operating systems respond to a restart signal from this button. If your operating system does not respond to a restart signal, restart from within the operating system, as you would with a physical machine.

**Run VMware Tools Scripts** — This option allows you to run scripts when you power on a virtual machine. See [Command Line Reference on page 91](#) for help with scripting.

## Shared Folders

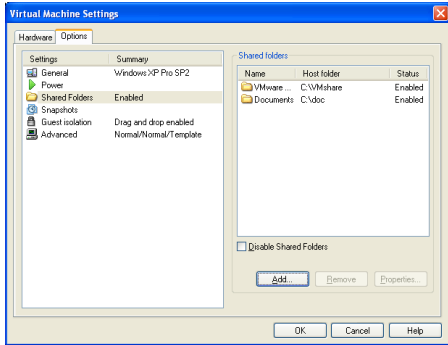

**Shared Folders** — This option allows a virtual machine to share a folder with the host file system for convenient file transfers. See [Using Shared Folders on page 157](#) for help configuring this option.

## Snapshots

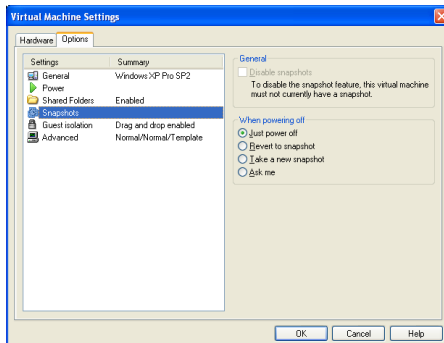

**General** — You can disable snapshots for the virtual machine. The virtual machine must not have any snapshots if you want to disable snapshots.

To disable snapshots for this virtual machine, select **Disable snapshots**.

**When powering off** — You can specify the way Workstation handles snapshots when you power off the virtual machine. Options when powering off include:

- **Just power off** — powers off without making any changes to snapshots.
- **Revert to the snapshot** — reverts to the parent snapshot of the virtual machine's current state (that is, the parent snapshot of the You Are Here position in the Snapshot Manager window) so the virtual machine always starts in the state it was in when the parent snapshot was taken.
- **Take a new snapshot** — takes a new snapshot of the virtual machine state after it is powered off.
- **Ask me** — always asks what you want to do with snapshots when you power off.

See [Using Snapshots on page 251](#) for more information on setting these options.



## Guest Isolation (Windows only)

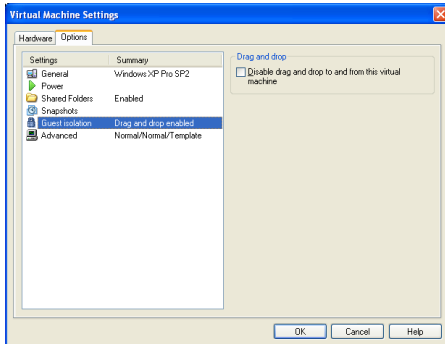

**Drag and Drop** — By default, you can drag and drop files between your host computer and a virtual machine. If you wish to disable this feature, select **Disable drag and drop to and from the virtual machine**.

One reason to disable the drag and drop feature is to prevent files from accidentally being transferred between the virtual machine and the host.

## Advanced

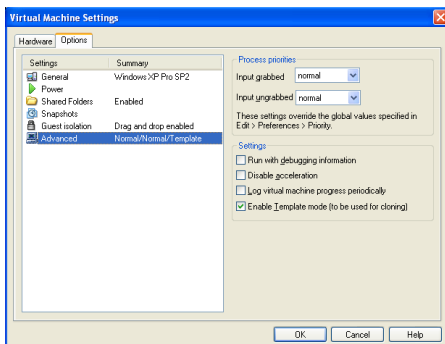

**Process priorities** (Windows only) — VMware Workstation sets the default priority for virtual machine processing as Normal for both Input grabbed and Input ungrabbed. This means that the processes within virtual machines contend equally for resources with all other processes running on the host.

To change the default priority for the selected virtual machine, overriding the global priorities, choose the priority you want, then click **OK**.

You can also set the global priorities directly from a Workstation window by choosing **Edit > Preferences** and clicking the **Priority** tab.

- **Settings**

- **Run with debugging information** — You can run a virtual machine so it collects additional debugging information that is helpful to VMware technical support in resolving issues.

To turn debugging mode on, select **Run with debugging information**, then click **OK** to apply your changes

- **Disable acceleration** — In rare instances, you may find that when you install or run software inside a virtual machine, Workstation appears to hang. Generally, the problem occurs early in the program's execution. In many cases, you can get past the problem by temporarily disabling acceleration in the virtual machine.

To disable acceleration, select **Disable acceleration**, then click **OK**.

This setting slows down virtual machine performance, so it is recommended only for getting past the problem with running the program. After you pass the point where the program was encountering problems, try returning to the virtual machine settings editor and removing the check beside **Disable acceleration**. You may then be able to run the program with acceleration.

- **Log virtual machine progress periodically** — This special configuration option increases logging information for debugging and troubleshooting purposes. When you select this option, you do not have to edit a configuration file or restart the virtual machine to extract more detailed logging for technical support.
- **Enable Template mode (to be used for cloning)** — See [Linked Clones and Access to the Parent Virtual Machine on page 274](#) for help configuring this option.

# Command Line Reference

The following sections describe command line options that are available when you launch VMware Workstation and keyboard shortcuts you can use while VMware Workstation is running.

## Startup Options on a Linux Host

The following list describes various options available when you run VMware Workstation from the command line on a Linux host operating system.

```
VMware [-x] [-X] [-q] [-s <variablename>=<value>]
[-m] [-v] [/<path_to_config>/<config>.virtual_machinex ]
[X toolkit options ]
```

You can type these commands manually in a terminal window, or create scripts to run multiple commands.

Option	Description
-x	Automatically powers on the virtual machine when VMware Workstation starts. This is equivalent to clicking the <b>Power On</b> button in the VMware Workstation toolbar.
-X	Automatically powers on the virtual machine, then switches the VMware Workstation window to full screen mode.
-q	Closes the virtual machine's tab when the virtual machine powers off. If no other virtual machine is open, it also exits VMware Workstation. This is particularly useful when the guest operating system is capable of powering off the virtual machine.
-s	Sets the specified variable to the specified value. Any variable names and values that are valid in the configuration file may be specified on the command line with the -s switch.
-m	Starts the program in quick switch mode on a Linux host.
-v	Displays the product name, version and build number.
/<path_to_config>/<config>.vmx	Launches a virtual machine using the specified configuration file.

X toolkit options can be passed as arguments, although some of them (most notably the size and title of the VMware Workstation window) cannot be overridden.

X toolkit options are not relevant on a Windows host.

## Startup Options on a Windows Host

Most of the switches described in [Startup Options on a Linux Host](#) can also be used on a Windows host. The `-m` switch is for Linux hosts only. The most convenient way to use the switches is to incorporate them into the command generated by a Windows shortcut.

Create the shortcut, right-click the shortcut, then click **Properties**. In the **Target** field, add any switches you want to use after the `VMware.exe` filename. For example, the following command launches the Windows Me virtual machine specified, powers it on automatically and switches to full screen mode.

```
"C:\Program Files\VMware\VMware Workstation\Programs\VMware.exe -X  
C:\Documents and Settings\\My Documents\My Virtual  
Machines\Windows Me\Windows Me.vmx"
```

Be sure to enclose the entire command string in quotation marks.

**Note:** The configuration file has a `.vmx` extension by default.

## Command Line Application

VMware Workstation includes a separate application, `vmrun`, for operating teams or virtual machines from the command line.

To launch the `vmrun` application, from the command prompt, enter:

```
vmrun COMMAND [OPTION]
```

Valid `vmrun` commands and options are described in the following table:

Command	Description	Option
<code>list</code>	Lists all running virtual machines.	None
<code>start</code>	Start a virtual machine	Path to <code>.vmx</code> file
<code>stop</code>	Stop a virtual machine or team.	Path to <code>.vmx</code> file (virtual machine) or Path to <code>.vmtm</code> file (team)
<code>reset</code>	Reset a virtual machine or team.	Path to <code>.vmx</code> file (virtual machine) or Path to <code>.vmtm</code> file (team)
<code>suspend</code>	Suspend a virtual machine or team.	Path to <code>.vmx</code> file (virtual machine) or Path to <code>.vmtm</code> file (team)
<code>upgradevm</code>	Upgrade a virtual machine to the current Workstation version.	Path to <code>.vmx</code> file

**Note:** Before running this command on a Windows host, you must do one of the following:

- Change your working directory to the VMware Workstation directory. The default location is:  
`c:\Program Files\VMware\VMware Workstation`
- Add the VMware Workstation directory to the system path. On Windows 2000 and XP, this setting is changed from

**Control Panels > System > Advanced > Environment Variables > System variables > Path**

### Examples for vmrun

For example, to start a virtual machine:

- In a Linux terminal, enter

```
vmrun start /usr/local/VMs/<virtual_machine_name>.vmx
```

- On the Windows command line, enter:

```
vmrun start c:\My Virtual Machines\<virtual_machine_name>.vmx
```

With virtual machines that require input through a VMware Workstation dialog box, vmrun may time out and fail. To disable Workstation dialog boxes, insert the following line into the `.vmx` configuration file for a virtual machine:

```
msg.autoAnswer = TRUE
```

## Keyboard Shortcuts

If you prefer to work from the keyboard as much as possible, you may find the following keyboard shortcuts handy. If you have changed the Preferences setting for the hot-key combination, substitute your new setting for Ctrl-Alt as needed in the shortcuts listed here.

Shortcut	Action
Ctrl-B	Power on.
Ctrl-E	Power off.
Ctrl-R	Reset the power.
Ctrl-Z	Suspend.
Ctrl-N	Create a new virtual machine.
Ctrl-O	Open a virtual machine.
Ctrl-F4	Close the summary/console view for the selected virtual machine. A confirmation dialog appears only if the virtual machine is powered on.
Ctrl-D	Edit the virtual machine's configuration.
Ctrl-G	Grab input from keyboard and mouse.
Ctrl-P	Edit preferences.
Ctrl-Alt-Enter	Go to full screen mode.
Ctrl-Alt	Return to normal (windowed) mode.
Ctrl-Alt-Tab	Switch among open virtual machines while mouse and keyboard input are grabbed.
Ctrl-Tab	Switch among open virtual machines while mouse and keyboard input are not grabbed. VMware Workstation must be the active application.
Ctrl-Shift-Tab	Switch among open virtual machines while mouse and keyboard input are not grabbed. VMware Workstation must be the active application.
Ctrl-Alt-Fx	<p><b>Linux hosts:</b> Switch among open virtual machines while using full screen mode. Fx is a function key corresponding to the virtual machine you want to use. The key combination to use for a virtual machine is shown in the VMware Workstation title bar when that virtual machine is active and in normal (windowed) mode.</p> <p><b>Windows hosts:</b> For an additional similar functionality, see <a href="#">Using Full Screen Switch Mode on page 438</a>.</p>

## What Files Make Up a Virtual Machine?

You may never need to know the file names or locations for your virtual machine files. Virtual machine file management is performed by VMware Workstation. If the behind the scenes file structure is not interesting to you, skip this section.

A virtual machine typically is stored on the host computer in a set of files, usually in a directory created by Workstation for that specific virtual machine.

The key files are listed here by extension. In these examples, <vmname> is the name of your virtual machine

Extension	File Name	Description
.log	<vmname>.log or vmware.log	This is the file that keeps a log of key VMware Workstation activity. This file can be useful in troubleshooting if you encounter problems. This file is stored in the directory that holds the configuration (.vmtx) file of the virtual machine.
.nvram	<vmname>.nvram or nvram	This is the file that stores the state of the virtual machine's BIOS.



Extension	File Name	Description
.vmdk	<vmname>.vmdk	<p>This is a virtual disk file, which stores the contents of the virtual machine's hard disk drive.</p> <p>A virtual disk is made up of one or more .vmdk files. If you have specified that the virtual disk should be split into 2GB chunks, the number of .vmdk files depends on the size of the virtual disk. As data is added to a virtual disk, the .vmdk files grow in size, to a maximum of 2GB each. (If you specify that all space should be allocated when you create the disk, these files start at the maximum size and do not grow.) Almost all of a .vmdk file's content is the virtual machine's data, with a small portion allotted to virtual machine overhead.</p> <p>If the virtual machine is connected directly to a physical disk, rather than to a virtual disk, the .vmdk file stores information about the partitions the virtual machine is allowed to access.</p> <p>Earlier VMware products used the extension .disk for virtual disk files.</p>
	<diskname>-<###>.vmdk	<p>This is a redo-log file, created automatically when a virtual machine has one or more snapshots. This file stores changes made to a virtual disk while the virtual machine is running. There may be more than one such file. The ### indicates a unique suffix added automatically by VMware Workstation to avoid duplicate file names.</p>
.vmsd	<vmname>.vmsd	This is a centralized file for storing information and metadata about snapshots.
.vmsn	<vmname>-Snapshot.vmsn	This is the snapshot state file, which stores the running state of a virtual machine at the time you take that snapshot
	<vmname>-Snapshot<###>.vmsn	This is the file which stores the state of a snapshot
.vmss	<vmname>.vmss	<p>This is the suspended state file, which stores the state of a suspended virtual machine</p> <p>.Some earlier VMware products used the extension .std for suspended state files</p>

Extension	File Name	Description
.vmtm	<vmname>.vmtm	This is the configuration file containing team data.
.vmx	<vmname>.vmx	This is the primary configuration file, which stores settings chosen in the New Virtual Machine Wizard or virtual machine settings editor. If you created the virtual machine under an earlier version of VMware Workstation on a Linux host, this file may have a .cfg extension
.vmxf	<vmname>.vmxf	This is a supplemental configuration file for virtual machines that are in a team. Note that the .vmxf file remains if a virtual machine is removed from the team.

There can be other files in the directory, some of which are present only while a virtual machine is running.

## Where to Go Next

- [Creating a New Virtual Machine on page 101](#)
- [Running VMware Workstation on page 139](#)



# CHAPTER 5

## Creating a New Virtual Machine

---

This chapter discusses how to create a new virtual machine and install VMware Tools:

- [Setting Up a New Virtual Machine on page 102](#)
- [Converting a VirtualPC Virtual Machine on page 113](#)
- [Installing a Guest Operating System and VMware Tools on page 117](#)
  - [Example: Installing Windows XP as a Guest Operating System on page 117](#)
- [Installing VMware Tools on page 120](#)
  - [VMware Tools for Windows Guests on page 120](#)
  - [VMware Tools for Linux Guests on page 122](#)
  - [VMware Tools for FreeBSD Guests on page 127](#)
  - [Installing VMware Tools in a NetWare Virtual Machine on page 129](#)
- [VMware Tools Configuration Options on page 130](#)
  - [Using the System Console to Configure VMware Tools in a NetWare Guest Operating System on page 135](#)

## Setting Up a New Virtual Machine

The New Virtual Machine Wizard guides you through the key steps for setting up a new virtual machine, helping you set various options and parameters. You can then use the virtual machine settings editor (**VM > Settings**) if you need to make any changes to your virtual machine's setup.

### Steps to a New Virtual Machine

By default, the new virtual machine uses an IDE disk for Windows 95, Windows 98, Windows Me, Windows XP, Windows Server 2003, NetWare and FreeBSD guests. The default for other guest operating systems is a SCSI disk.

Follow these steps to create a virtual machine using a virtual disk.

1. Start VMware Workstation.

**Windows hosts:** Double-click the VMware Workstation icon on your desktop or use the **Start** menu (**Start > Programs > VMware > VMware Workstation**).

**Linux hosts:** In a terminal window, enter the command

```
vmware &
```

**Note:** On Linux hosts, the Workstation installer adds an entry to the Start menu for VMware Workstation. However, this menu entry is located in different submenus, depending on your Linux distribution. For example:

- SUSE Linux 9.1 — **Start > System > More Programs > VMware Workstation**
  - Red Hat Enterprise Linux AS/WS Release 3 — **Start > System Tools > More System Tools > VMware Workstation**
2. If this is the first time you have launched VMware Workstation and you did not enter the serial number when you installed the product (an option available on a Windows host), you are prompted to enter it. The serial number is on the registration card in your package or in the email message confirming your electronic distribution order. Enter your serial number and click **OK**.

The serial number you enter is saved and VMware Workstation does not ask you for it again. For your convenience, VMware Workstation automatically sends the serial number to the VMware Web site when you use certain Web links built into the product (for example, **Help > VMware on the Web > Register Now!** and **Help > VMware on the Web > Request Support**). This allows us to direct you to the correct Web page to register and get support for your product.

3. Start the New Virtual Machine Wizard.

When you start VMware Workstation, you can open an existing virtual machine or create a new one. Choose **File > New > Virtual Machine** to begin creating your virtual machine.

4. The New Virtual Machine Wizard presents you with a series of screens that you navigate using the Next and Prev buttons at the bottom of each screen. At each screen, follow the instructions, then click **Next** to proceed to the next screen.



5. Select the method you want to use for configuring your virtual machine.

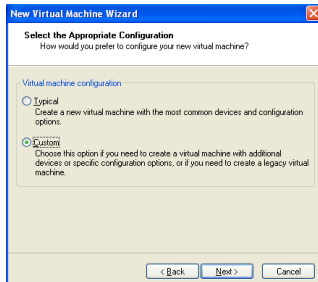

If you select **Typical**, the wizard prompts you to specify or accept defaults for the following choices:

- The guest operating system
- The virtual machine name and the location of the virtual machine's files
- The network connection type
- Whether to allocate all the space for a virtual disk at the time you create it
- Whether to split a virtual disk into 2GB files

If you select **Custom**, you also can specify how to set up your disk — create a new virtual disk, use an existing virtual disk or use a physical disk — and specify the settings needed for the type of disk you select. There is also an option to create a legacy virtual disk for use in environments with other VMware products.

Select **Custom** if you want to

- Make a legacy virtual machine that is compatible with Workstation 4.x, GSX Server 3.x, ESX Server 2.x and ACE 1.x.
- Make a virtual disk larger or smaller than 4GB
- Store your virtual disk's files in a particular location
- Use an IDE virtual disk for a guest operating system that would otherwise have a SCSI virtual disk created by default
- Use a physical disk rather than a virtual disk (for expert users)
- Set memory options that are different from the defaults



6. If you selected **Typical** as your configuration path, skip to step 7.

If you selected **Custom** as your configuration path, you may create a virtual machine that fully supports all Workstation 5 features or a legacy virtual machine compatible with specific VMware products.

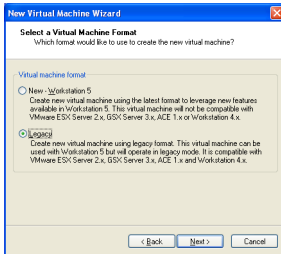

This screen asks whether you want to create a Workstation 5 virtual machine or a legacy virtual machine. See [Legacy Virtual Disks on page 246](#) for more information.

7. Select a guest operating system.

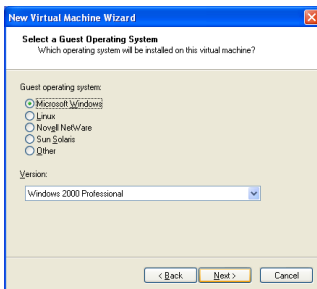

This screen asks which operating system you plan to install in the virtual machine. Select both an operating system and a version. The New Virtual Machine Wizard uses this information to

- Select appropriate default values, such as the amount of memory needed
- Name files associated with the virtual machine
- Adjust settings for optimal performance
- Work around special behaviors and bugs within a guest operating system

If the operating system you plan to use is not listed, select **Other** for both guest operating system and version.

The remaining steps assume you plan to install a Windows XP Professional guest operating system. You can find detailed installation notes for this and other guest operating systems in the *VMware Guest Operating System Installation Guide*, available from the VMware Web site or from the Help menu.

8. Select a name and folder for the virtual machine.

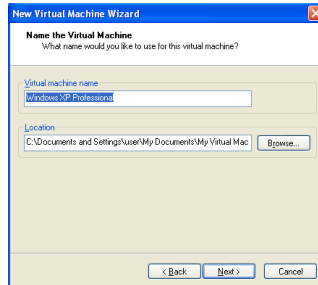

The name specified here is used if you add this virtual machine to the VMware Workstation Favorites list. This name is also used as the name of the folder where the files associated with this virtual machine are stored.

Each virtual machine should have its own folder. All associated files, such as the configuration file and the disk file, are placed in this folder.

**Windows hosts:** On Windows 2000, Windows XP and Windows Server 2003, the default folder for this Windows XP Professional virtual machine is `C:\Documents and Settings\\My Documents\My Virtual Machines\Windows XP Professional`. On Windows NT, the default folder is `C:\WINNT\Profiles\\Personal\My Virtual Machines\Windows XP Professional`.

**Linux hosts:** The default location for this Windows XP Professional virtual machine is `<homedir>/vmware/winXPro`, where `<homedir>` is the home directory of the user who is currently logged on.

Virtual machine performance may be slower if your virtual hard disk is on a network drive. For best performance, be sure the virtual machine's folder is on a local drive. However, if other users need to access this virtual machine, you should consider placing the virtual machine files in a location that is accessible to them. For more information, see [Sharing Virtual Machines with Other Users on page 184](#).

9. If you selected **Typical** as your configuration path, skip to step 10.

If you selected **Custom** as your configuration path, you may adjust the memory settings or accept the defaults, then click **Next** to continue.

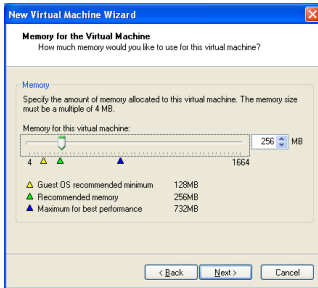

In most cases, it is best to keep the default memory setting. If you plan to use the virtual machine to run many applications or applications that need high amounts of memory, you may want to use a higher memory setting. For more information, see [Virtual Machine Memory Size on page 418](#).

**Note:** You cannot allocate more than 2GB of memory to a virtual machine if the virtual machine's files are stored on a file system such as FAT32 that does not support files greater than 2GB.

10. Configure the networking capabilities of the virtual machine.

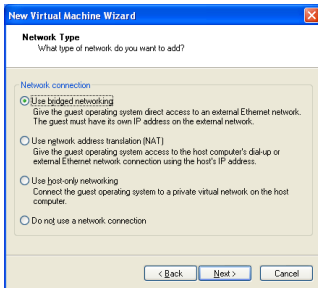

If your host computer is on a network and you have a separate IP address for your virtual machine (or can get one automatically from a DHCP server), select **Use bridged networking**.

If you do not have a separate IP address for your virtual machine but you want to be able to connect to the Internet, select **Use network address translation (NAT)**. NAT allows you to share files between the virtual machine and the host operating system.

For more details about VMware Workstation networking options, see [Configuring a Virtual Network on page 305](#).

11. If you selected **Typical** as your configuration path, click **Finish** and the wizard sets up the files needed for your virtual machine.

If you selected **Custom** as your configuration path, continue with the steps below to configure a disk for your virtual machine.

12. Select the type of SCSI adapter you want to use with the virtual machine.

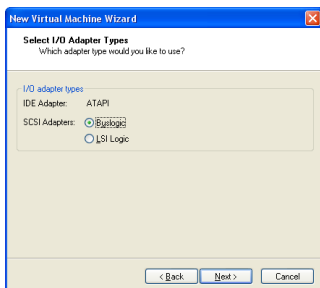

An IDE and a SCSI adapter are installed in the virtual machine. The IDE adapter is always ATAPI. You can choose a BusLogic or an LSI Logic SCSI adapter. The default for your guest operating system is already selected. All guests except for Windows Server 2003, Red Hat Enterprise Linux 3 and NetWare default to the BusLogic adapter.

The LSI Logic adapter has improved performance and works better with generic SCSI devices. The LSI Logic adapter is also supported by ESX Server 2.0 and higher. Keep this in mind if you plan to migrate the virtual machine to another VMware product.

Your choice of SCSI adapter does not affect your decision to make your virtual disk an IDE or SCSI disk. However, some guest operating systems — such as Windows XP — do not include a driver for the Buslogic or LSI Logic adapter. You must download the driver from the LSI Logic Web site.

**Note:** Drivers for a Mylex (BusLogic) compatible host bus adapter are not obvious on the LSI Logic Web site. Search the support area for the numeric string in the model number. For example, search for “958” for BT/KT-958 drivers.

See the *VMware Guest Operating System Installation Guide* for details about the driver and the guest operating system you plan to install in this virtual machine.

13. Select the disk you want to use with the virtual machine.

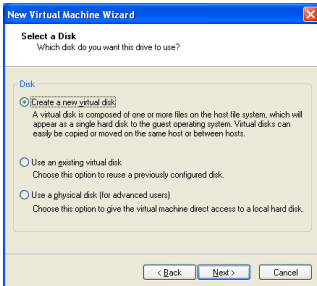

Select **Create a new virtual disk**.

Virtual disks are the best choice for most virtual machines. They are quick and easy to set up and can be moved to new locations on the same host computer or to different host computers. By default, virtual disks start as small files on the host computer's hard drive, then expand as needed — up to the size you specify in the next step. The next step also allows you to allocate all the disk space when the virtual disk is created, if you wish.

To use an existing operating system on a physical hard disk (a “raw” disk), read [Configuring a Dual-Boot Computer for Use with a Virtual Machine on page 215](#). To install your guest operating system directly on an existing IDE disk partition, read the reference note [Installing an Operating System onto a Physical Partition from a Virtual Machine on page 241](#).

**Note:** Raw disk configurations are recommended only for expert users.

**Caution:** If you are using a Windows Server 2003, Windows XP or Windows 2000 host, see [Do Not Use Windows 2000, Windows XP and Windows Server 2003 Dynamic Disks as Raw Disks on page 234](#).

To install the guest operating system on a raw IDE disk, select **Existing IDE Disk Partition**. To use a raw SCSI disk, add it to the virtual machine later with the virtual machine settings editor. Booting from a raw SCSI disk is not supported. For a discussion of some of the issues involved in using a raw SCSI disk, see [Configuring Dual- or Multiple-Boot SCSI Systems to Run with VMware Workstation on a Linux Host on page 235](#).

14. Select whether to create an IDE or SCSI disk.

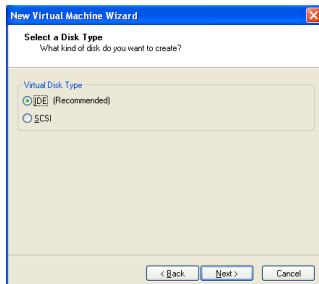

The wizard recommends the best choice based on the guest operating system you selected. All Linux distributions you can select in the wizard use SCSI virtual disks by default, as do Windows NT, Windows 2000 and Longhorn. All Windows operating systems except Windows NT, Windows 2000 and Longhorn use IDE virtual disks by default; NetWare, FreeBSD, MS-DOS and other guests default to IDE virtual disks.

15. Specify the capacity of the virtual disk.

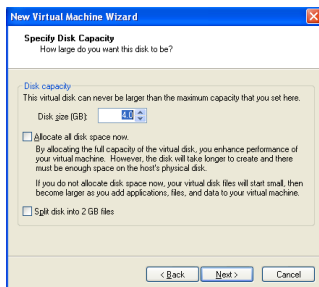

Enter the size of the virtual disk that you wish to create.

You can set a size between 0.1GB and 950 GB for a SCSI virtual disk . The default is 4GB.

The option **Allocate all disk space now** gives somewhat better performance for your virtual machine. If you do not select **Allocate all disk space now**, the virtual disk's files start small and grow as needed, but they can never grow larger than the size you set here.

**Note:** **Allocate all disk space now** is a time-consuming operation that cannot be cancelled, and requires as much physical disk space as you specify for the virtual disk.

Select the option Split disk into 2GB files if your virtual disk is stored on a file system that does not support files larger than 2GB.

- Specify the location of the virtual disk's files.

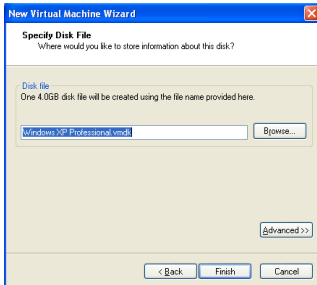

If you want to specify which device node should be used by your SCSI or IDE virtual disk, click **Advanced**.

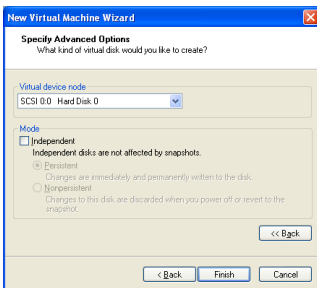

On the advanced settings panel, you can also specify a disk mode. This is useful in certain special-purpose configurations in which you want to exclude disks from snapshots. For more information on the snapshot feature, see [Using Snapshots on page 251](#).

Normal disks are included in snapshots. In most cases, you should use normal disks, leaving **Independent** unchecked.

Independent disks are not included in snapshots.

**Caution:** The independent disk option should be used only by advanced users who need it for special-purpose configurations.

You have the following options for an independent disk:

- **Persistent** — changes are immediately and permanently written to the disk.
- **Nonpersistent** — changes to the disk are discarded when you power off the virtual machine.

17. Click **Finish**.

The wizard sets up the files needed for your virtual machine.



# Converting a VirtualPC Virtual Machine

VMware Virtual Machine Importer is a separate downloadable application that creates a new VMware virtual machine from a Microsoft VirtualPC virtual machine in a few simple steps.

You must install Virtual Machine Importer to use this procedure. The most up-to-date instructions appear the Virtual Machine Importer User's Manual. See [www.vmware.com/pdf/vm\\_importer\\_manual.pdf](http://www.vmware.com/pdf/vm_importer_manual.pdf)

To migrate a VirtualPC virtual machine:

1. Ensure the VirtualPC virtual machine is powered off.
 

**Note:** You cannot migrate a virtual machine while it is operating.
2. Launch Virtual Machine Importer to start the wizard.
 

**Start > Programs > VMware > Virtual Machine Importer**
3. From the opening panel, click **Next**.



4. Select the configuration and click **Next**.

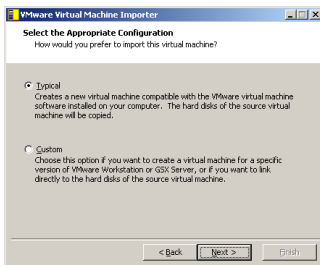

5. Browse (or type the path) to the source VirtualPC virtual machine. Click **Next**.

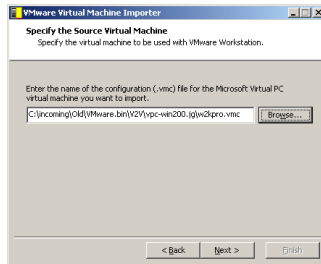

Virtual Machine Importer inspects the file momentarily.

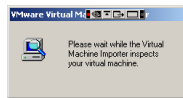

6. Browse or type the path to the location you want to create a VMware virtual machine and click **Next**.

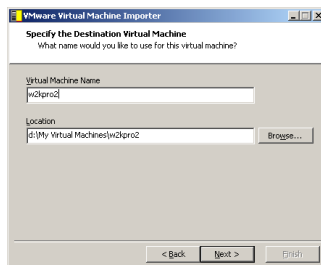

7. If you did not select **Custom** in step 4, skip to step 9.

Select the format of the virtual machine.

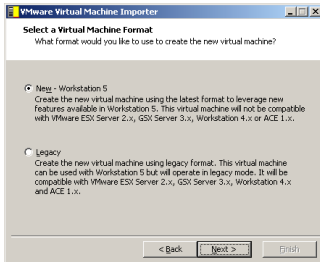

- Select **New** if you want to use the virtual machine only with Workstation 5.0.
- Select **Legacy** if you want to use the virtual machine with Workstation 4, ESX 2.x, GSX Server 3.x or ACE 1.x.

Click **Next**.

8. Select the import options for the new virtual machine

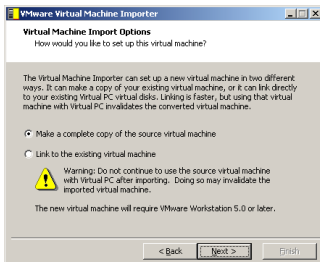

- **Make a complete copy of the source virtual machine** — This creates a VMware virtual machine with no dependencies on the original VirtualPC virtual machine.
- **Link to the existing virtual machine** — This creates a VMware virtual machine that shares the virtual disk of the source VirtualPC virtual machine. This option is disabled if you chose to create a legacy virtual machine in step 7.

**Caution:** Linking to the disk file is faster than making a complete copy, but selecting this option means your VMware virtual machine can stop functioning if you ever use the source virtual machine in VirtualPC again.

Click **Next**.

- Review the description of the migration settings. To make changes, click **Back**. When you are satisfied with the settings, click **Next**.

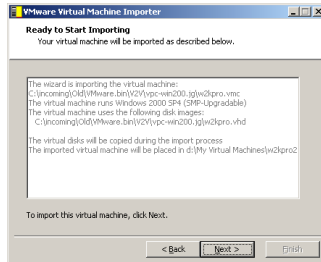

Virtual Machine Importer creates a VMware virtual machine from the source VirtualPC.

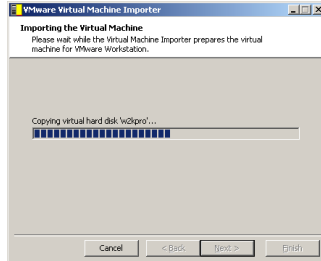

A progress bar appears. To stop the migration, click **Cancel**.

The migration process can often take more than a minute per gigabyte of disk space of the migrated virtual machine. When the migration is complete, Virtual Machine Importer displays a completion dialog box.



- To use the virtual machine immediately, select **Start my virtual machine now**. Virtual Machine Importer then launches VMware Workstation when it closes.
- Click **Finish**.

# Installing a Guest Operating System and VMware Tools

A new virtual machine is like a physical computer with a blank hard disk. Before you can use it, you need to partition and format the virtual disk and install an operating system. The operating system's installation program may handle the partitioning and formatting steps for you.

Installing a guest operating system inside your VMware Workstation virtual machine is essentially the same as installing it on a physical computer. The basic steps for a typical operating system are:

1. Start VMware Workstation.
2. Insert the installation CD-ROM or floppy disk for your guest operating system.

**Note:** In some host configurations, the virtual machine is not able to boot from the installation CD-ROM. You can work around that problem by creating an ISO image file from the installation CD-ROM. Use the virtual machine settings editor to connect the virtual machine's CD drive to the ISO image file, then power on the virtual machine.

3. Power on your virtual machine by clicking the **Power On** button.
4. Follow the instructions provided by the operating system vendor.

The next section provides notes on installing a Windows XP guest operating system. The screen shots illustrate the process on a Windows host. The steps are the same on a Linux host.

For information on installing other guest operating systems, see the *VMware Guest Operating System Installation Guide*, available from the VMware Web site or from the Help menu.

## Example: Installing Windows XP as a Guest Operating System

You can install Windows XP Home Edition or Windows XP Professional in a virtual machine using the full installation CD.

Before installing the operating system, be sure that you have already created a new virtual machine and configured it using the New Virtual Machine Wizard. See [Setting Up a New Virtual Machine on page 102](#).

**Note:** To use SCSI disks in a Windows XP virtual machine, you need a special SCSI driver available from the download section of the VMware Web site. Follow the instructions on the Web site to use the driver with a fresh installation of Windows XP.

## Installation Steps

1. If you prefer, you can insert the Windows XP CD in the CD-ROM drive

You can alternately connect to an ISO image of an installation disk. See [Connecting a CD-ROM or Floppy Drive to an Image File on page 207](#).

**Note:** If you plan to use a PXE server to install the guest operating system over a network connection, you do not need the operating system installation media. When you power on the virtual machine in the next step, the virtual machine detects the PXE server.

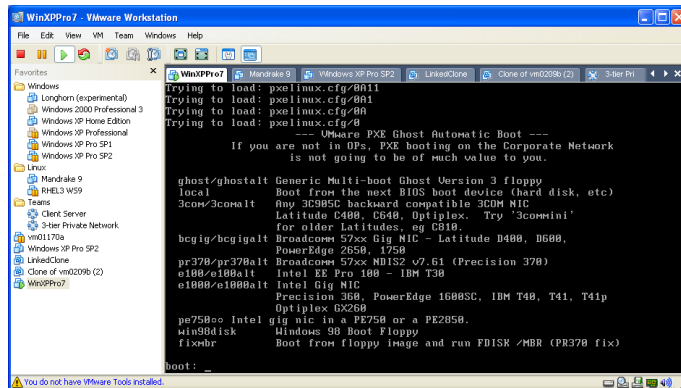

*VMware Workstation detects a PXE server on boot*

2. Power on the virtual machine to start installing Windows XP.

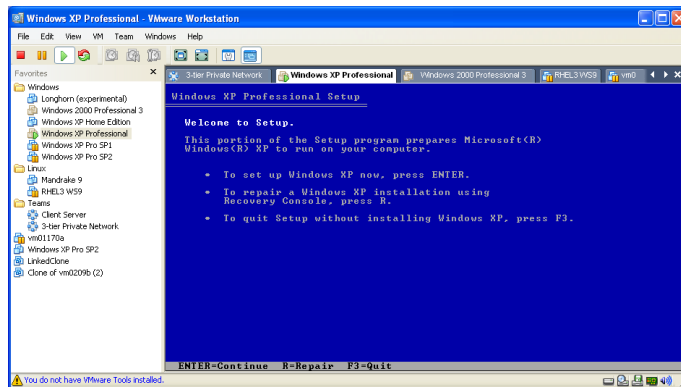

- Follow the Windows XP installation steps as you would for a physical computer.

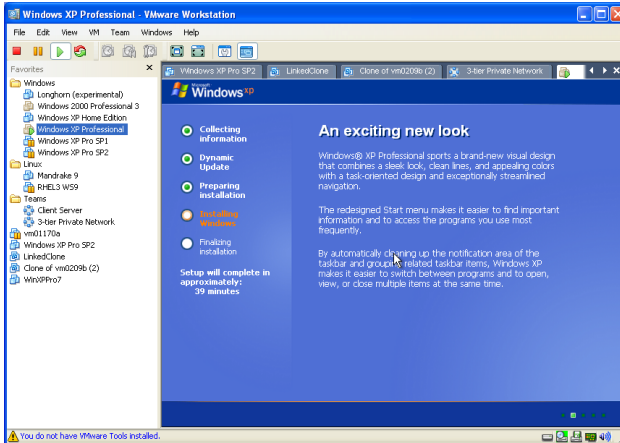

- When the installer is finished, you have a virtual machine running Windows XP. Don't forget to install VMware Tools, as described in the next section.

# Installing VMware Tools

## Don't Forget VMware Tools

It is very important that you install VMware Tools in the guest operating system.

With the VMware Tools SVGA driver installed, Workstation supports significantly faster graphics performance.

The VMware Tools package provides support required for shared folders and for drag and drop operations.

Other tools in the package support synchronization of time in the guest operating system with time on the host, automatic grabbing and releasing of the mouse cursor, copying and pasting between guest and host, and improved mouse performance in some guest operating systems.

The installers for VMware Tools for Windows, Linux, FreeBSD, and NetWare guest operating systems are built into VMware Workstation as ISO image files. (An ISO image file looks like a CD-ROM to your guest operating system and even appears as a CD-ROM in Windows Explorer. You do not use an actual CD-ROM to install VMware Tools, nor do you need to download the CD-ROM image or burn a physical CD-ROM of this image file.)

When you choose **VM > Install VMware Tools** from the VMware Workstation menu, VMware Workstation temporarily connects the virtual machine's first virtual CD-ROM drive to the ISO image file that contains the VMware Tools installer for your guest operating system and you are ready to begin the installation process.

## Upgrading VMware Tools

Now you can upgrade VMware Tools without uninstalling the previous version.

However, it is a good idea to upgrade the virtual machine first. See [Procedure to Upgrade Virtual Machines on page 59](#)

To upgrade VMware Tools, follow the installation procedure for your guest operating system in the next sections.

## VMware Tools for Windows Guests

VMware Tools for Windows supports Windows 95, Windows 98, Windows Me, Windows NT 4.0, Windows 2000, Windows XP and Windows Server 2003 guest operating systems.

The detailed steps for installing VMware Tools depend on the version of Windows you are running. The steps that follow show how to install VMware Tools in a Windows XP



guest. Some steps that are automated in newer versions of Windows must be performed manually in Windows 9x and Windows NT.

**Note:** If you are running VMware Workstation on a Windows host and your virtual machine has only one CD-ROM drive, the CD-ROM drive must be configured as an IDE or SCSI CD-ROM drive. It cannot be configured as a generic SCSI device.

To add an IDE or SCSI CD-ROM drive, see [Adding, Configuring, and Removing Devices in a Virtual Machine on page 164](#). For information about generic SCSI, see [Connecting to a Generic SCSI Device on page 402](#).

### Installing VMware Tools in a Windows Guest Operating System

1. Power on the virtual machine.
2. When the guest operating system starts, select **VM > Install VMware Tools**.

The remaining steps take place inside the virtual machine.

**Note:** You must log on to a Windows NT, Windows 2000, Windows XP, Windows Server 2003 or Longhorn guest operating system as an administrator in order to install VMware Tools. Any user can install VMware Tools in a Windows 95, Windows 98 or Windows Me guest operating system.

3. If you have autorun enabled in your guest operating system (the default setting for Windows operating systems), a dialog box appears after a few seconds. It asks if you want to install VMware Tools. Click **Yes** to launch the InstallShield wizard.

If autorun is not enabled, the dialog box does not appear automatically. If it doesn't appear, run the VMware Tools installer. Click **Start > Run** and enter `D:\setup\setup.exe` where D: is your first virtual CD-ROM drive.

4. Follow the on-screen instructions.
  - On Windows Server 2003, Windows Me, Windows 98 SE and Windows 98 guests, the SVGA driver is installed automatically and the guest operating system uses it after it reboots.
  - With Windows 2000 and Windows XP guests, you do not have to reboot to use the new driver.

## VMware Tools for Linux Guests

On a Linux guest, you can install VMware Tools within X or from the command line

- [Installing VMware Tools within X on page 122](#)
- [Installing VMware Tools from the Command Line with the Tar Installer on page 123](#)
- [Installing VMware Tools from the Command Line with the RPM Installer on page 124](#)

### Installing VMware Tools within X

You can install VMware Tools within X using the .tar installer in a terminal window. See [Installing VMware Tools from the Command Line with the Tar Installer on page 123](#).

To install VMware Tools from X with the RPM installer:

1. Choose **VM > Install VMware Tools**.

The guest operating system mounts the VMware Tools installation virtual CD.

2. Double-click the VMware Tools CD icon on the desktop.

**Note:** In some Linux distributions, the VMware Tools CD icon may fail to appear when you install VMware Tools within an X windows session on a guest. In this case, you should continue installing VMware Tools as described in [Installing VMware Tools from the Command Line with the Tar Installer on page 123](#), beginning with step 3.

3. Double-click the RPM installer in the root of the CD-ROM.
4. Enter the root password.
5. Click **Continue**.

The installer prepares the packages.

6. Click **Continue** when the installer presents a dialog box saying Completed System Preparation.

A dialog appears for **Updating system**, with a progress bar. When the installer is done, VMware Tools are installed. There is no confirmation or finish button.

7. In an X terminal, as root (`su -`), configure VMware Tools.

```
vmware-config-tools.pl
```

Respond to the questions the installer displays on the screen. Press Enter to accept the default value.

**Note:** Be sure to respond yes when the installer offers to run the configuration program.

8. Launch the VMware Tools background application:

```
vmware-toolbox &
```

**Note:** Some guest operating systems require a reboot for full functionality.

### Installing VMware Tools from the Command Line with the Tar Installer

The first steps are performed on the host, within Workstation menus:

1. Power on the virtual machine.
2. After the guest operating system has started, prepare your virtual machine to install VMware Tools.

Choose **VM > Install VMware Tools**.

The remaining steps take place inside the virtual machine.

3. As root (**su -**), mount the VMware Tools virtual CD-ROM image, change to a working directory (for example, **/tmp**), uncompress the installer, then unmount the CD-ROM image.

**Note:** Some Linux distributions automatically mount CD-ROMs. If your distribution uses automounting, do not use the mount and umount commands below. You still must untar the VMware Tools installer to **/tmp**.

Some Linux distributions use different device names or organize the **/dev** directory differently. If your CD-ROM drive is not **/dev/cdrom** or if the mount point for a CD-ROM is not **/mnt/cdrom**, you must modify the following commands to reflect the conventions used by your distribution.

```
mount /dev/cdrom /mnt/cdrom
cd /tmp
```

**Note:** If you have a previous installation, delete the previous **vmware-distrib** directory before installing. The default location of this directory is **/tmp/vmware-tools-distrib**.

4. Untar the VMware Tools tar file:

```
tar xzf /mnt/cdrom/VMwareTools-5.0.0-<xxxx>.tar.gz
umount /dev/cdrom
```

Where **<xxxx>** is the build/revision number of the VMware Workstation release.

**Note:** If you attempt to install a **tar** installation over an **rpm** installation — or the reverse — the installer detects the previous installation and must convert the installer database format before continuing.

- Run the .tar VMware Tools installer:

```
cd vmware-tools-distrib
./vmware-install.pl
```

Respond to the configuration questions on the screen. Press Enter to accept the default value.

- Log off of the root account.

```
exit
```

- Start X and your graphical environment.

- In an X terminal, launch the VMware Tools background application.

```
vmware-toolbox &
```

**Note:** You may run VMware Tools as root or as a normal user. To shrink virtual disks, you must run VMware Tools as root (`su -`).

### Installing VMware Tools from the Command Line with the RPM Installer

The first steps are performed on the host, within Workstation menus:

- Power on the virtual machine.
- After the guest operating system has started, prepare your virtual machine to install VMware Tools.

Choose **VM > Install VMware Tools**.

The remaining steps take place inside the virtual machine.

- As root (`su -`), mount the VMware Tools virtual CD-ROM image, change to a working directory (for example, `/tmp`), uncompress the installer, then unmount the CD-ROM image.

**Note:** Some Linux distributions automatically mount CD-ROMs. If your distribution uses automounting, do not use the mount and umount commands below. You still must untar the VMware Tools installer to `/tmp`.

Some Linux distributions use different device names or organize the `/dev` directory differently. If your CD-ROM drive is not `/dev/cdrom` or if the mount point for a CD-ROM is not `/mnt/cdrom`, you must modify the following commands to reflect the conventions used by your distribution.

```
mount /dev/cdrom /mnt/cdrom
cd /tmp
```

**Note:** If you have a previous installation, delete the previous `vmware-distrib` directory before installing. The default location of this directory is `/tmp/vmware-tools-distrib`.

- At the command prompt, enter:

```
rpm -Uhv /mnt/cdrom/VMwareTools-5.0.0-
<xxxx>.i386.rpm
umount /dev/cdrom
```

Where `<xxxx>` is the build/revision number of the VMware Workstation release.

**Note:** If you attempt to install an `rpm` installation over a `tar` installation — or the reverse — the installer detects the previous installation and must convert the installer database format before continuing.

- Configure VMware Tools:

```
vmware-config-tools.pl
```

Respond to the questions the installer displays on the screen. Press Enter to accept the default value.

- Log off of the root account.

```
exit
```

- Start X and your graphical environment.

- In an X terminal, launch the VMware Tools background application.

```
vmware-toolbox &
```

**Note:** You may run VMware Tools as root or as a normal user. To shrink virtual disks, you must run VMware Tools as root (`su -`).

### Starting VMware Tools Automatically

You may find it helpful to configure your guest operating system so VMware Tools starts when you start your X server. The steps for doing so vary depending on your Linux distribution and your desktop environment. Check your operating system documentation for the appropriate steps to take.

For example, in a Red Hat Linux 7.1 guest using GNOME, follow these steps.

- Open the Startup Programs panel in the GNOME Control Center.
  - Main Menu** (click the foot icon in the lower left corner of the screen) > **Programs**
  - > **Settings** > **Session** > **Startup Programs**
- Click **Add**.
- In the **Startup Command** field, enter `vmware-toolbox`.
- Click **OK**, click **OK** again, then close the GNOME Control Center.

The next time you start X, VMware Tools starts automatically.

### Uninstalling VMware Tools

To remove VMware Tools from your Linux guest operating system, log on as root (su -) and enter the following command:

- From a tar install

```
vmware-uninstall-tools.pl
```

- From an RPM install

```
rpm -e VMwareTools
```

## VMware Tools for FreeBSD Guests

1. Power on the virtual machine.
2. Select **VM > Install VMware Tools**.

The remaining steps take place inside the virtual machine, not on the host computer.

3. Be sure the guest operating system is running in text mode. You cannot install VMware Tools while X is running.
4. As root (`su -`), mount the VMware Tools virtual CD-ROM image, change to a working directory (for example, `/tmp`), uncompress the installer, then unmount the CD-ROM image.

**Note:** You do not use an actual CD-ROM to install VMware Tools, nor do you need to download the CD-ROM image or burn a physical CD-ROM of this image file. The VMware Workstation software contains an ISO image that looks like a CD-ROM to your guest operating system. This image contains all the files needed to install VMware Tools in your guest operating system.

**Note:** Some FreeBSD distributions automatically mount CD-ROMs. If your distribution uses automounting, do not use the mount and unmount commands below. You still must untar the VMware Tools installer to `/tmp`.

```
mount /cdrom
```

```
cd /tmp
```

Untar the VMware Tools tar file:

```
tar xzf /cdrom/vmware-freebsd-tools.tar.gz
umount /cdrom
```

5. Run the VMware Tools installer.

Using the tar installer

```
cd vmware-tools-distrib
./vmware-install.pl
```

6. Log out of the root account.

```
exit
```

7. Start X and your graphical environment

8. In an X terminal, launch the VMware Tools background application.

```
vmware-toolbox &
```

**Note:** You may run VMware Tools as root or as a normal user. To shrink virtual disks, you must run VMware Tools as root (`su -`).

**Note:** In a FreeBSD 4.5 guest operating system, sometimes VMware Tools does not start after you install VMware Tools, reboot the guest operating system or start VMware Tools on the command line in the guest. An error message appears:

```
Shared object 'libc.so.3' not found.
```

The required library was not installed. This does not happen with full installations of FreeBSD 4.5, but does occur for minimal installations. To fix the problem of the missing library, take the following steps:

1. Insert and mount the FreeBSD 4.5 installation CD or access the ISO image file.
2. Change directories and run the installation script.

```
cd /cdrom/compat3x  
./install.sh
```



## Installing VMware Tools in a NetWare Virtual Machine

1. Power on the virtual machine.
2. Select **VM > Install VMware Tools**.

The remaining steps take place inside the virtual machine.

3. Load the CD-ROM driver so the CD-ROM device mounts the ISO image as a volume. Do one of the following.
  - In the system console for a NetWare 6.5 virtual machine, type  
`LOAD CDDVD`
  - In the system console for a NetWare 6.0 or NetWare 5.1 virtual machine, type  
`LOAD CD9660.NSS`
4. When the driver finishes loading, you can begin installing VMware Tools. In the system console, type  
`vmwtools:\setup.ncf`  
When the installation finishes, the message **VMware Tools for NetWare are now running** appears in the Logger Screen (NetWare 6.5 and NetWare 6.0 guests) or the Console Screen (NetWare 5.1 guests).
5. Restart the guest operating system. In the system console, type

```
restart server
```

After you install VMware Tools, make sure the VMware Tools virtual CD-ROM image (`netware.iso`) is not attached to the virtual machine. If it is, disconnect it. Right-click the CD-ROM icon in the status bar of the console window and select **Disconnect**.

## VMware Tools Configuration Options

This section discusses VMware Tools configuration options in the following topics.

- [Using the Control Panel to Configure VMware Tools on page 130](#)
- [Using the System Console to Configure VMware Tools in a NetWare Guest Operating System on page 135](#)

### Using the Control Panel to Configure VMware Tools

This section shows the options available in a Windows XP guest operating system. Similar configuration options are available in VMware Tools for other guest operating systems.

When VMware Tools is running, an icon with the VMware boxes logo appears in the guest operating system's system tray.



To open the VMware Tools control panel, double-click the VMware Tools icon in the system tray.

If the VMware Tools icon does not appear in the system tray, go to **Start > Control Panel**. Locate the VMware Tools icon and double-click it.

Tabs in the VMware Tools control panel are described in the following sections.

## The Options Tab

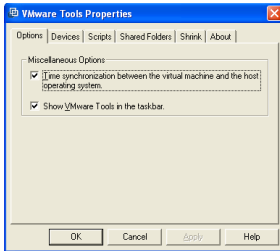

The Options tab shows the Miscellaneous Options.

- Time synchronization between the virtual machine and the host operating system

**Note:** You can synchronize the time in the guest operating system with the time on the host operating system only when you set the clock in the guest operating system to a time earlier than the time set on the host.

Under some circumstances, the virtual machine may synchronize time with the host even though this item is not selected. If you want to disable time synchronization completely, open the virtual machine's configuration file (`.vmx`) in a text editor and set the following options to **FALSE**.

```
tools.syncTime
tools.synchronize.restore
time.synchronize.resume.disk
time.synchronize.continue
time.synchronize.shrink
```

- Show VMware Tools in the taskbar

## The Devices Tab

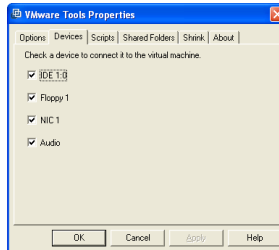

The Devices tab allows you to enable or disable removable devices. (You can also enable or disable removable devices in **VM > Removable Devices**.)

## The Scripts Tab

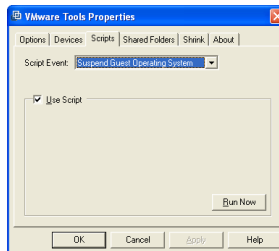

Use the Scripts tab to enable, disable and run scripts for the Suspend, Resume, Power On, and Power Off buttons.

**Windows hosts:** If the virtual machine is configured to use DHCP, the script executed when suspending a virtual machine releases the IP address of the virtual machine. The script executed when resuming a virtual machine renews the IP address of the virtual machine.

**Linux hosts:** The script executed when suspending a virtual machine stops networking for the virtual machine. The script executed when resuming a virtual machine starts networking for the virtual machine.

To run one of these scripts at some other time, select the script you want from the drop-down menu, then click **Run Now**.

To disable all scripts, deselect **Use Scripts**.

**Note:** Scripts cannot be run in Windows 95, NetWare, and FreeBSD guest operating systems.

**Note:** Scripts in Windows NT and Windows Me guest operating systems do not release and renew the IP address.

## The Shared Folders Tab

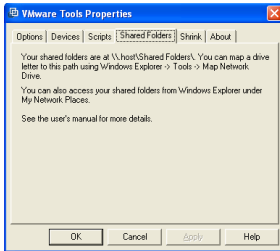

The Shared Folders tab provides information on where to find your shared folders. For more information on shared folders, see [Using Shared Folders on page 157](#).

## The Shrink Tab

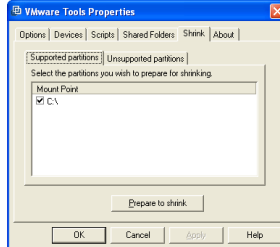

*Shrink disk enabled: supported partitions*

The Shrink tab gives you access to controls that reclaim unused space in a virtual disk. However, some configurations do not allow you to shrink a virtual disk. For more information, see [Shrinking Virtual Disks on page 193](#).

## The About Tab

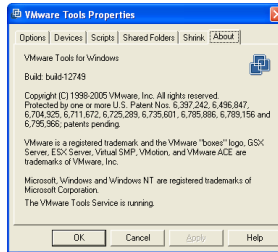

The About tab displays version and copyright information. In Windows guests, this tab also shows the status of the VMWare Tools Service.

## Using the System Console to Configure VMware Tools in a NetWare Guest Operating System

You can configure certain virtual machine options such as time synchronization, CPU idling and device configuration with VMware Tools in a NetWare virtual machine using the system console. The VMware Tools command line program is called `vmwtool`. To see the options associated with this command, at the system console, type

```
vmwtool help
```

### Summary of VMware Tools Commands for a NetWare Guest

Each command in the following table must be entered into the system console after the VMware Tools command `vmwtool`. Use the following format:

```
vmwtool <command>
```

vmwtool Command	Definition
<code>help</code>	Displays a summary of VMware Tools commands and options in a NetWare guest.
<code>partitionlist</code>	Displays a list of all disk partitions in the virtual disk and whether or not a partition can be shrunk.
<code>shrink &lt;partition&gt;</code>	Shrinks the listed partitions. If no partitions are specified, then all partitions in the virtual disk are shrunk. The status of the shrink process appears at the bottom of the system console.
<code>devicelist</code>	Lists each removable device in the virtual machine, its device ID and whether the device is enabled or disabled. Removable devices include the virtual network adapter, CD-ROM and floppy drives.
<code>disabledevice &lt;device name&gt;</code>	Disables the specified device or devices in the virtual machine. If no device is specified, then all removable devices in the virtual machine are disabled.
<code>enabledevice &lt;device name&gt;</code>	Enables the specified device or devices in the virtual machine. If no device is specified, then all removable devices in the virtual machine are enabled.

vmwtool Command	Definition
<code>synctime [on off]</code>	<p>Lets you turn on or off synchronization of time in the guest operating system with time on the host operating system. By default, time synchronization is turned off.</p> <p>Use this command without any options to view the current time synchronization status.</p> <p>You can synchronize the time in the guest operating system with time on the host operating system only when the time in the guest operating system is earlier than the time set in the host.</p>
<code>idle [on off]</code>	<p>Lets you turn the CPU idler on or off. By default, the idler is turned on. The CPU idler program is included in VMware Tools for NetWare guests.</p> <p>The idler program is needed because NetWare servers do not idle the CPU when the operating system is idle. As a result, a virtual machine takes CPU time from the host regardless of whether the NetWare server software is idle or busy.</p>



## Where to Go Next

- [Running VMware Workstation on page 139](#)
- [Using Disks on page 187](#)
- [Moving and Sharing Virtual Machines on page 169](#)
- [Preserving the State of a Virtual Machine on page 249](#)
- [Cloning a Virtual Machine on page 267](#)
- [Configuring Teams on page 277](#)
- [Configuring a Virtual Network on page 305](#)
- [Configuring Video and Sound on page 359](#)
- [Connecting Devices on page 371](#)
- [Performance Tuning on page 407](#)



# Running VMware Workstation

---

This chapter discusses launching the VMware Workstation program and various tasks you may want to perform in daily use, after you have installed VMware Workstation, a guest operating system and VMware Tools.

- [Starting a Virtual Machine on page 141](#)
- [Checking the Status of VMware Tools on page 142](#)
- [Suspending and Resuming Virtual Machines on page 143](#)
- [Shutting Down a Virtual Machine on page 144](#)
- [Resetting a Virtual Machine on page 145](#)
- [Taking and Reverting to a Snapshot on page 146](#)
- [Cloning a Virtual Machine on page 147](#)
- [Deleting a Virtual Machine on page 148](#)
- [Using Virtual Machine Teams on page 149](#)

- [Controlling the Display on page 150](#)
- [Installing New Software on page 155](#)
- [Cutting, Copying and Pasting Text on page 156](#)
- [Using Shared Folders on page 157](#)
- [Using Drag and Drop on page 163](#)
- [Using Devices in a Virtual Machine on page 164](#)
- [Creating a Screen Shot or a Movie of a Virtual Machine on page 165](#)

The illustrations in these sections show a Windows XP guest operating system. Some commands used in the illustrations are different from those used in other guest operating systems.

# Starting a Virtual Machine

To start a virtual machine

1. Start Workstation. For instructions, see [Launching VMware Workstation on page 62](#).
1. Select the name of the virtual machine you want to use in the Favorites list at the left of the Workstation window.  
  
If the virtual machine you want to use is not shown there, choose File > Open and browse to the configuration (.vmx) file for the virtual machine you want to use.  
  
Refer to [Virtual Machine Location on page 141](#) for help finding virtual machines on your host operating system.
2. Click the **Power On** button to start the virtual machine.
3. Click anywhere inside the virtual machine window to give the virtual machine control of your mouse and keyboard.
4. If you need to log on, type your name and password just as you would on a physical computer.

**Note:** If your Windows guest operating system asks you to press Ctrl-Alt-Del before logging in, press Ctrl-Alt-Ins, instead.

## Virtual Machine Location

**On Windows hosts** VMware Workstation stores virtual machines in the `My Documents` folder of the user who is logged on when the virtual machine is created.

On Windows Server 2003, Windows XP and Windows 2000, the default folder is `C:\Documents and Settings\\My Documents\My Virtual Machines\<guestOSname>`.

**On Linux hosts** VMware Workstation stores virtual machines in `<homedir>/VMware/<guestOSname>`, where `<homedir>` is the home directory of the user who is logged on when the virtual machine is created.

## Checking the Status of VMware Tools

For best performance, it is important to have VMware Tools installed and running in your virtual machine.

After you install VMware Tools in a Windows virtual machine, the VMware Tools services start automatically when you start the guest operating system.



*When VMware Tools is running in a Windows virtual machine, the VMware Tools icon appears in the system tray unless you disable the icon.*

If the VMware Tools icon is not displayed in the system tray, you can use the VMware Tools control panel in the guest operating system. Go to **Start > Settings > Control Panel** or **Start > Control Panel**, depending on the version of Windows you are using, locate the VMware Tools icon and double-click it to change settings for VMware Tools. You can also reactivate the system tray icon. On the **Options** tab, select **Show VMware Tools in the taskbar**.

In a Linux or FreeBSD virtual machine, boot the guest operating system, start X and launch your graphical environment. Then you can launch the VMware Tools background application with this command:

```
vmware-toolbox &
```

You may run VMware Tools as root or as a normal user. To shrink virtual disks, you must run VMware Tools as root (**su -**).

With some window managers, you can place the command to start VMware Tools in a startup configuration so VMware Tools starts automatically when you start your graphical environment. Consult your window manager's documentation for details.

# Suspending and Resuming Virtual Machines

You can save the current state of your virtual machine by suspending it. Later, you can resume the virtual machine to pick up work quickly, right where you stopped — with all documents you were working on open and all applications in the same state as they were at the time you suspended the virtual machine.

To suspend a virtual machine

1. If your virtual machine is running in full screen mode, return to window mode by pressing the Ctrl-Alt key combination.
2. Click **Suspend** on the VMware Workstation toolbar.
3. When VMware Workstation has completed the suspend operation, it is safe to exit VMware Workstation.

**File > Exit** (Windows)

or

**File > Quit** (Linux)

To resume a virtual machine that you have suspended:

1. Start VMware Workstation and choose a virtual machine you have suspended. The process is the same as that described in [Starting a Virtual Machine on page 141](#).
2. Click **Resume** on the VMware Workstation toolbar.

Note that any applications you were running at the time you suspended the virtual machine are running and the content is the same as it was when you suspended the virtual machine.

For more information, see [Using Suspend and Resume on page 250](#).

## Shutting Down a Virtual Machine

As with physical computers, you need to shut down your guest operating system before you power off your virtual machine or team. For example, in a Windows guest operating system, take these steps:

1. Choose **Shut Down** from the **Start** menu of the guest operating system (inside the virtual machine).
2. Choose **Shut Down**, then click **OK**.
3. After the guest operating system shuts down, you can turn off the virtual machine. Click **Power Off**.

Now it is safe to exit VMware Workstation or power off a team.

If you are using a different guest operating system, the procedure is similar. Follow the usual steps to shut down the guest operating system inside your virtual machine, then turn off the virtual machine with the **Power Off** button.

### Power Off vs. Shut Down

You can configure the Power Off button to turn off a virtual machine or team in two ways:

- You can set the Power Off button to work as a power switch works on a power supply. The virtual machine is abruptly powered off, with no consideration for work in progress.

**Caution:** If a virtual machine is writing to disk when it receives a Power Off command, data corruption may occur.

- You can also set the Power Off button to send a shut down signal to the guest operating system. An operating system that recognizes this signal shuts down gracefully.

**Note:** Not all guest operating systems respond to a shut down signal from this button. If your operating system does not respond to a shut down signal, shut down from within the operating system, as you would with a physical machine.

For instructions on configuring the Power Off button, see Power Controls in the section [Power on page 85](#).



## Resetting a Virtual Machine

As with physical computers, you may need to reset a guest operating system that has become unresponsive. This is generally not recommended: If you reset a virtual machine while the virtual disk is being written to, data may be lost or corrupted.

To reset a virtual machine, click the **Reset button** on the toolbar.

### Reset vs. Restart

You can configure the Reset button to reset or restart a virtual machine or team.

- You can set the Reset button to work as a reset switch, so that it resets the virtual machine abruptly, with no consideration for work in progress.
- You can also set the Reset button to send a restart signal to the guest operating system. An operating system that recognizes this signal shuts down gracefully and restarts.

**Note:** Not all guest operating systems respond to a restart signal from this button. If your operating system does not respond to a restart signal, restart from within the operating system, as you would with a physical machine.

For instructions on configuring the Reset button, see Power Controls in the section [Power](#) on page 85.

## Taking and Reverting to a Snapshot

VMware Workstation lets you take snapshots of a virtual machine at any time. A snapshot preserves the state of all virtual machine disks and the virtual machine's power state: powered on, powered off, or suspended.

You can take a new snapshot or revert to any previous snapshot at any time. When you revert to a snapshot, you discard all changes made to the virtual machine since the most recent snapshot. Multiple snapshots allow you to preserve different states of the same virtual machine.

Use the **Take Snapshot** and **Revert** buttons on the Workstation toolbar to take a snapshot and revert to it later. For more information, including examples of ways you can use snapshots, see [Using Snapshots on page 251](#).

## Cloning a Virtual Machine

A clone is a copy of a virtual machine. You can do anything with a clone that you could with the original virtual machine.

Installing a guest operating system and applications can be time consuming. By cloning a virtual machine, you can easily deploy many copies of a fully configured virtual machine, without the need to install the same operating system and applications in each copy.

Clones may be linked or full:

- A full clone is an independent copy of a virtual machine that shares nothing with the parent virtual machine after the cloning operation. Ongoing operation of a full clone is entirely separate from the parent virtual machine.
- A linked clone is a copy of a virtual machine that shares virtual disks with the parent virtual machine in an ongoing manner. This conserves disk space, and allows multiple virtual machines to use the same software installation.

The Clone Virtual Machine Wizard automatically copies everything required for a duplicate virtual machine. You don't have to locate the original virtual machine files, identify the files needed, and copy them manually. The Clone Virtual Machine Wizard automatically creates a new MAC address and other unique identifiers for the duplicate virtual machine.

Refer to [Cloning a Virtual Machine on page 267](#) for more information regarding clones.

## Deleting a Virtual Machine

Workstation 5 includes commands to remove a virtual machine from the Favorites list or completely delete the virtual machine. You do not need to manipulate files in the host file system to delete a virtual machine.

- To remove a virtual machine or team name from the Favorites list, right-click the name and choose **Remove from Favorites**. This choice does not affect the virtual machine itself; all virtual machine and team files remain intact on the host computer file system.
- To delete a virtual machine from the host computer, right-click the name of the virtual machine in the Favorites list and select **Delete from Disk**; or, select the virtual machine and choose **VM > Delete from disk**.

VMware Workstation allows you to delete a virtual machine even if it is a member of a team. To delete a team itself, see [Closing a Team on page 284](#).

## Using Virtual Machine Teams

A team is a group of networked virtual machines that act together. Power operations are applied to an entire team, with startup order and delay time before startup fully configurable for each virtual machine on the team.

Teams are useful for multitier application development, testing, demonstration, and deployment. LAN segments allow you to create private virtual networks for performance testing and security.

The New Team Wizard guides you through creation of a new team. Add virtual machines and LAN segments to deploy a completely private testing environment or one that interacts with your network as usual.

Refer to the [Configuring Teams on page 277](#) for a complete description of teams.

## Controlling the Display

You can control the VMware Workstation display in a variety of ways to suit the way you prefer to work with your virtual machines.

- [Using Full Screen Mode on page 150](#)
- [Using Quick Switch Mode on page 151](#)
- [Taking Advantage of Multiple Monitors on page 151](#)
- [Fitting the Workstation Console to the Virtual Machine Display on page 152](#)
- [Nonstandard Resolutions on page 153](#)
- [Simplifying the Screen Display on page 153](#)

### Using Full Screen Mode

In full screen mode, the VMware Workstation virtual machine display fills the screen, so you no longer see the borders of the VMware Workstation window. To enter full screen mode, click the **Full Screen** button on the toolbar, or press Ctrl-Alt-Enter.

To switch from full screen mode back to normal mode, which shows your virtual machine inside a VMware Workstation window again, press Ctrl-Alt.

Virtual machines run faster in full screen mode.

**Linux hosts:** You can switch between virtual machines without leaving full screen mode by using a Ctrl-Alt-Fn key combination, where Fn is a function key corresponding to the virtual machine you want to see. To find out what function key to use for a particular virtual machine, check the title bar of the virtual machine while it is running in a window.

**Windows hosts:** For similar functionality, see [Using Full Screen Switch Mode on page 438](#).

**Note:** VMware Workstation does not support running virtual machines in full screen mode on dual-monitor systems.

## Using Quick Switch Mode

Quick switch mode is similar to full screen mode with the addition of tabs at the top of the screen for switching from one active virtual machine to another. The virtual machine's screen is resized to fill the screen completely, except for the space occupied by the tabs.

To enter quick switch mode, choose **View > Quick Switch**.

To view the VMware Workstation menu and toolbar while you are using quick switch mode, move the mouse pointer to the top of the screen.

To resize a Windows guest operating system's display so it fills as much of the screen as possible in quick switch mode, choose **View > Fit Guest Now**. The Fit Guest Now option works only if you have the current version of VMware Tools installed in the guest operating system.

**Note:** When you choose **Fit Guest Now**, VMware Workstation adjusts the display settings of your Windows guest operating system as needed. If you subsequently run the virtual machine in normal mode, you may want to change the display settings back to their previous values.

To get out of quick switch mode, move the mouse pointer to the top of the screen to activate the menu, then choose **View > Quick Switch**.

## Taking Advantage of Multiple Monitors

If your host has a standard multiple monitor display, you can run separate sets of virtual machines on each of the monitors. To use two monitors, launch two instances of VMware Workstation. Start one or more virtual machines in each VMware Workstation window, then drag each VMware Workstation window to the monitor on which you want to use it. For the largest possible screen display, switch each of the windows to quick switch mode (**View > Quick Switch**).

To switch mouse and keyboard input from the virtual machine on the first screen to the virtual machine on the second screen, move the mouse pointer from one to the other. You do not need to take any special steps if VMware Tools is running in both guest operating systems and if you are using the default settings for grabbing input. If you have changed the defaults, you may need to press Ctrl-Alt to release the mouse pointer from the first virtual machine, move it to the second virtual machine, then click in the second virtual machine so it will grab control of mouse and keyboard input.

**Note:** Multiple monitor support is experimental in this release of VMware Workstation. It does not work properly with some third-party desktop management software or display drivers.

**Note:** If you switch to full screen mode, VMware Workstation always uses the primary display. To use multiple monitors, you must use either the normal (windowed) mode or quick switch mode.

## Fitting the Workstation Console to the Virtual Machine Display

The **View** menu autofit and fit commands allow you to match the VMware Workstation console with the guest operating system display size.

View Menu Command	Description
Autofit Window <sup>†</sup>	This command causes the Workstation console to maintain the size of the virtual machine's display resolution. If the guest operating system changes its resolution, the Workstation console automatically resizes to match the new resolution.
Autofit Guest <sup>†</sup>	This command causes the virtual machine to resize the guest display resolution to match the size of the Workstation console.
Fit Window Now <sup>‡</sup>	This command causes the Workstation console to match the current display size of the guest operating system.
Fit Guest Now <sup>‡</sup>	This command causes the guest operating system display size to match the current Workstation console.
<p><sup>†</sup> An autofit command is toggled on or off each time you select it. If both Autofit commands are toggled on, then you can manually resize the Workstation console, but the guest operating system can also resize the Workstation console</p> <p><sup>‡</sup> This command is redundant when one of the autofit options is active, because the console and the guest operating system display are the same size.</p>	

With both autofit commands toggled off, VMware Workstation does not automatically match window sizes as you work. Scroll bars appear in the console when the Workstation console is smaller than the guest operating system display. A black border appears in the console when the console is larger than the guest operating system display.



## Nonstandard Resolutions

A guest operating system — and its applications — may react unexpectedly when the Workstation console size is not a standard VESA resolution (e.g. 640×480, 800×600, 1024×768, etc.).

For example, the **Autofit Guest** and **Fit Guest** commands allow your guest operating system screen resolution to be set smaller 640×480, and some installers do not run at resolutions smaller than 640×480. Programs may refuse to run. Error messages may include such phrases as “VGA Required To Install” or “You must have VGA to install.”

There are two ways to work around this problem with nonstandard resolutions.

- If your host computer's screen resolution is high enough, you can enlarge the window, then choose **Fit Guest**.
- If your host computer's screen resolution does not allow you to enlarge the Workstation console sufficiently, you can manually set the guest operating system's screen resolution to 640×480 or larger.

## Simplifying the Screen Display

If you prefer, you can turn off display of many of the controls visible in the VMware Workstation window.

Use the **View** menu to toggle the following controls on or off:

- Favorites
- Toolbar
- Status bar
- Virtual machine tabs

On a Windows host, you can also hide the menu bar. To do so, click the title bar icon, then choose **Hide Controls**.

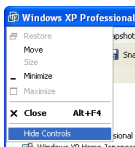

*Hiding the menu bar on a Windows host*

Choosing **Hide Controls** hides the menu bar, the toolbar, the status bar and the Favorites list.

For the simplest possible VMware Workstation window on a Windows host, first choose **View > Tabs** to turn off the tabs. Then, from the title bar icon shortcut menu, choose **Hide Controls**.

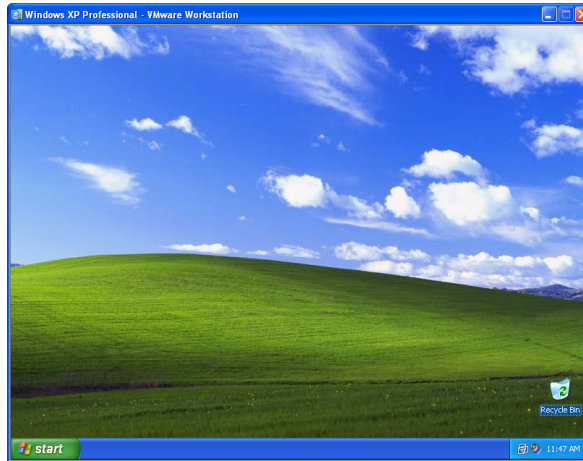

*With controls hidden, a virtual machine appears as a host*

Using the View menu and the title bar icon shortcut menu, you can remove all visible controls from the VMware Workstation window.

## Installing New Software

Installing new software in a VMware Workstation virtual machine is just like installing it on a physical computer. For example, to install software in a Windows virtual machine, take the following steps:

1. Be sure you have started the virtual machine and, if necessary, logged on. On the Workstation menus, choose **VM > Removable Devices** to be sure the virtual machine has access to the CD-ROM drive and, if needed, the floppy drive.
2. Insert the installation CD-ROM or floppy disk into the proper drive. If you are installing from a CD-ROM, the installation program may start automatically.
3. If the installation program does not start automatically, click the Windows **Start** button, go to **Settings > Control Panel**, then double-click **Add/Remove Programs** and click the **Install** button. Follow the instructions on screen and in the user manual for your new software.

**Note:** Some applications use a product activation feature that creates a key, based on the virtual hardware in the virtual machine where it is installed. Changes in the configuration of the virtual machine may require you to reactivate the software. To minimize the number of significant changes, set the final memory size for your virtual machine and install VMware Tools before you activate the software.

**Note:** When you try to run a few programs — including the installer for the Japanese-language version of Trend Micro Virus Buster — Workstation may appear to hang. For the workaround to this problem, see the following knowledge base article on the VMware Web site at [www.vmware.com/info?id=30](http://www.vmware.com/info?id=30).

## Cutting, Copying and Pasting Text

When VMware Tools is running, you can cut (or copy) and paste text between applications in the virtual machine and the host computer or between two virtual machines. Use the normal hot keys or menu choices to cut, copy and paste.

To turn off this feature — to prevent accidental copying and pasting from one environment to another — change your preferences.

Choose **Edit > Preferences**. On the Input tab, clear the check box beside **Enable copy and paste to and from virtual machine**.

## Using Shared Folders

With shared folders, you can easily share files among virtual machines and the host computer. To use shared folders, you must have the current version of VMware Tools installed in the guest operating system and you must configure your virtual machine settings to specify which directories are to be shared.

VMware Workstation 5 includes new performance enhancements for shared folders.

You can use shared folders with virtual machines running the following guest operating systems:

- Windows Server 2003
- Windows XP
- Windows 2000
- Windows NT 4.0
- Linux with a kernel version of 2.4 or higher

To set up one or more shared folders for a virtual machine, be sure the virtual machine is open in Workstation and click its tab to make it the active virtual machine. Choose **VM > Settings > Options** and click **Shared folders**.

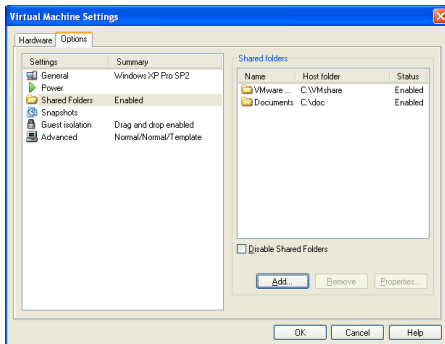

You can add one or more directories to the list. Those directories may be on the host computer or they may be network directories accessible from the host computer.

## Adding a Shared Folder on a Windows Host

(To add a shared folder on a Linux host, see [Adding a Shared Folder on a Linux Host on page 160](#).)

1. Choose **VM > Settings**
2. Select **Options**
3. Click **Shared Folders**
4. Click **Add** to open the Add Shared Folder Wizard and click **Next**



5. Enter a name and location for the shared folder and click **Next**

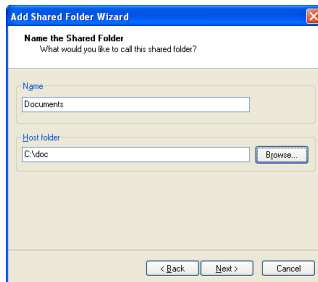

- **Name** — This is the name that appears inside the virtual machine.
- **Host folder** — The path on the host to the directory you want to share. Type in the full path or browse to the directory.

6. Enter attributes for the shared folder.

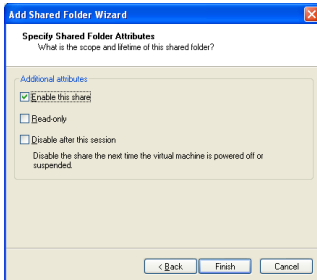

- **Enable this share** — Select this option to enable the shared folder. Deselect this option to disable the shared folder without deleting it from the virtual machine configuration. You may want to add a folder to the list without enabling it immediately. You can then enable the folder at any time by clicking its name in this list, clicking **Properties** and enabling the folder in the Properties dialog box.
  - **Read-only** — Select this option to prevent the virtual machine from changing the contents of the shared folder in the host file system. Access to files in the shared folder is also governed by permission settings on the host computer.
  - **Disable after this session** — Select this option to disable the virtual machine's connection to the folder when the virtual machine is powered off or suspended. Leave this box unchecked to specify that the folder is always enabled.
7. Click **Finish**.

## Adding a Shared Folder on a Linux Host

(To add a shared folder on a Windows host, see [Adding a Shared Folder on a Windows Host on page 158](#).)

1. Choose **VM > Settings**
2. Select **Options**
3. Click **Shared Folders**
4. Click **Add** to open the Shared Folder Properties dialog box.

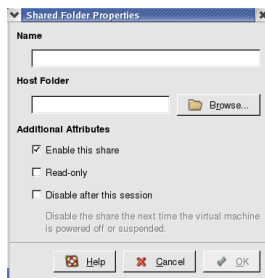

5. Enter the following information for the shared folder.
  - **Name** — This is the name that appears inside the virtual machine.
  - **Host folder** — The path on the host to the directory you want to share. Type in the full path or browse to the directory.
  - **Enable this share** — Select this option to enable the shared folder. Deselect this option to disable the shared folder without deleting it from the virtual machine configuration. You may want to add a folder to the list without enabling it immediately. You can then enable the folder at any time by clicking its name in this list, clicking **Properties** and enabling the folder in the Properties dialog box.
  - **Read-only** — Select this option to prevent the virtual machine from changing the contents of the shared folder in the host file system. Access to files in the shared folder is also governed by permission settings on the host computer.
  - **Disable after this session** — Select this option to disable the virtual machine's connection to the folder when the virtual machine is powered off or suspended. Deselect this option to specify that the folder is always enabled.
6. Click **OK**.



## Viewing a Shared Folder

Shared folders appear differently, depending on the guest operating system. The following sections describe viewing shared folders in Windows and Linux guests.

**Note:** You can use shared folders to share any type of file. However, Windows shortcuts and Linux symbolic links do not work correctly if you try to use them via shared folders.

**Caution:** Do not open a file in a shared folder from more than one application at a time. For example, you should not open the same file using an application on the host operating system and another application in the guest operating system. In some circumstances, doing so could cause data corruption in the file.

### Viewing Shared Folders in a Windows Guest

In a Windows guest operating system, you can view shared folders using Windows Explorer. Look in My Network Places (Network Neighborhood for a Windows NT guest) under VMware Shared Folders.

**Note:** If you have trouble finding a shared folder when using the desktop icon for My Network Places (or Network Neighborhood in Windows NT), instead open Windows Explorer and look in My Network Places (Network Neighborhood). The Windows desktop icon does not display an option for Entire Network.

For example, if you specify the name `Test files` for one of your shared folders, you can navigate to it by opening **My Network Places > VMware Shared Folders > .host > Shared Folders > Test files**.

You can also go directly to the folder using the UNC path  
`\\.\host\Shared Folders\Test files`.

You can map a shared folder to a drive letter just as you would with a network share.

**Note:** If your guest operating system has VMware Tools from Workstation 4.0, shared folders appear as folders on a designated drive letter.

### Viewing Shared Folders in a Linux Guest

In a Linux virtual machine, shared folders appear under `/mnt/hgfs`.

To change the settings for a shared folder on the list, click the folder's name to highlight it, then click **Properties**. The Properties dialog box appears.

Change any settings you wish, then click **OK**.

## Using Drag and Drop

With the drag and drop features of VMware Workstation 5, you can move files easily between a Windows host and a Windows virtual machine. You can drag and drop individual files or entire directories.

You can drag and drop files or folders from a file manager, such as Windows Explorer, on the host to a file manager in the virtual machine or vice versa. You can also drag files from a file manager to an application that supports drag and drop — or from applications such as zip file managers that support drag-and-drop extraction of individual files.

When you drag a file or folder from host to virtual machine or from virtual machine to host, Workstation copies the file or folder to the location where you drop it. This means, for example, that if you drop a file on the desktop icon of a word processor, the word processor opens with a copy of the original file. The original file does not reflect any changes you make to the copy.

Initially, the application opens using a copy of the file that is stored in your temp directory (as specified in the `%TEMP%` environment variable). To protect any changes you make, choose **File > Save As** from the application's menu and save the file in a different directory. Otherwise it may be overwritten or deleted by mistake.

To disable or enable drag and drop for a virtual machine

1. Open the virtual machine settings editor (**VM > Settings**), click the **Options** tab and select **Guest isolation**.
2. Select **Disable drag and drop to and from this virtual machine** to disable the feature. Deselect it to enable the feature.

## Using Devices in a Virtual Machine

Follow the guidelines in this section to add, remove, configure, connect, and disconnect your virtual machine's devices.

### Adding, Configuring, and Removing Devices in a Virtual Machine

In the virtual machine settings editor (**VM > Settings**), you can add and remove devices for a virtual machine, and change device settings.

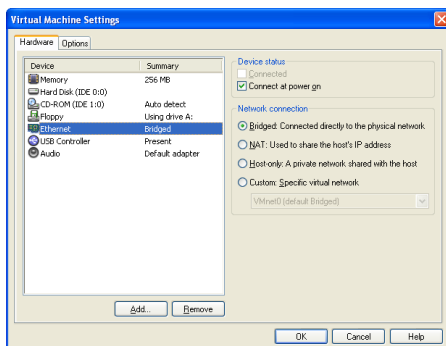

To add a new device to a virtual machine, open the virtual machine settings editor, click **Add**, and follow the instructions in the Add New Hardware Wizard. Click **OK** to save your changes and close the virtual machine settings editor.

To change settings for a device, open the virtual machine settings editor, select the device, and make your changes. Click **OK** to save your changes and close the virtual machine settings editor.

To remove a device, open the virtual machine settings editor, click the name of the device, and click **Remove**. Click **OK** to close the virtual machine settings editor.

### Connecting and Disconnecting Removable Devices

Choose **VM > Removable Devices** to connect and disconnect removable devices that you have configured for your virtual machine — including floppy drives, DVD/CD-ROM drives, USB devices, and Ethernet adapters — while the virtual machine is running.

When you choose **VM > Removable Devices**, a submenu appears. Choose a device from that menu to connect or disconnect it and to edit device settings. If you choose **Edit**, a dialog box appears. Make all the changes you want to make, then click **OK**.

# Creating a Screen Shot or a Movie of a Virtual Machine

This section describes how to capture a visual record of a virtual machine, in a screen shot or movie.

## Creating a Screen Shot of a Virtual Machine

You can capture a screen shot of a virtual machine. Choose **VM > Capture Screen**. You can save this image as a bitmap (.bmp) file on a Windows host or as a portable network graphics (.png) file on a Linux host.

## Creating a Movie of a Virtual Machine

You can capture a movie of your activity within a virtual machine. Workstation saves this image as an .avi file on the host.

To capture a movie of virtual machine activity

1. Choose **VM > Capture Movie**.
  - A save file dialog box appears.
2. Enter information for your movie and click **Save**.
  - Type the filename of the movie file you want to save. The default name is based on the active virtual machine.
  - Select the directory location where you want the movie to be stored.
  - Select High, Medium, or Low quality from the drop-down menu. This choice determines the compression and therefore the file size of the resulting movie.
  - If you select **Omit frames in which nothing occurs**, the movie will only include those periods of time when something is actually happening in the virtual machine. This reduces the file size and length of the movie.

While movie capture is active, a red circle — a virtual LED — appears in the status bar at the lower right.



*An indicator appears on the status bar during movie capture*

3. Within the virtual machine, perform the actions you want to appear in the movie.
4. Choose **VM > Stop Movie Capture**.

The red circle disappears from the status bar, and your movie is saved.

### **Playing a Movie Requires VMware CODEC**

You can play back your movie in any compatible media player. However, a VMware CODEC (coder-decoder) must be installed. This CODEC is automatically installed on a machine with VMware Workstation. A separately downloadable installer is also available for playback of movies on machines without VMware Workstation.

## Where to Go Next

- [Using Disks on page 187](#)
- [Moving and Sharing Virtual Machines on page 169](#)
- [Preserving the State of a Virtual Machine on page 249](#)
- [Cloning a Virtual Machine on page 267](#)
- [Configuring Teams on page 277](#)
- [Configuring a Virtual Network on page 305](#)
- [Configuring Video and Sound on page 359](#)
- [Connecting Devices on page 371](#)
- [Performance Tuning on page 407](#)





# Moving and Sharing Virtual Machines

---

The following sections provide information on how to move your virtual machines from one host to another, or elsewhere on the same host, plus recommendations on how to share virtual machines with other users:

- [Virtual Machine Identifier — UUID on page 170](#)
- [Moving a VMware Workstation 5 Virtual Machine on page 173](#)
- [Moving a VMware Workstation 4 Virtual Machine on page 176](#)
- [Moving an Older Virtual Machine on page 179](#)
- [Sharing Virtual Machines with Other Users on page 184](#)
- [Moving Linked Clones on page 185](#)

**Note:** When you move a virtual machine to a new host computer or to a different directory on the same host computer — or when you rename a directory in the path to the virtual machine's configuration file — VMware Workstation generates a different MAC address for the virtual Ethernet adapter. For additional information, see [Maintaining and Changing the MAC Address of a Virtual Machine on page 332](#).

## Virtual Machine Identifier — UUID

To ensure all virtual machines are identified properly, each virtual machine is automatically assigned a universal unique identifier (UUID).

If you move or copy a virtual machine, Workstation offers the choice of creating a new UUID the first time you power on the virtual machine. This new UUID is based on the physical computer's identifier and the path to the virtual machine's configuration file in its new location.

This section discusses the following topics:

- [The UUID Location and Format on page 170](#)
- [The UUID and Moving Virtual Machines on page 171](#)
- [Specifying a UUID for a Virtual Machine on page 172](#)
- [Setting the UUID for a Virtual Machine that Is Being Moved on page 172](#)

### The UUID Location and Format

The UUID is stored in the SMBIOS system information descriptor. It can be accessed by standard SMBIOS scanning software — for example SiSoftware Sandra or the IBM utility `smbios2` — and used for system management in the same way you use the UUID of a physical computer.

The UUID is a 128-bit integer. The 16 bytes of this value are separated by spaces, except for a dash between the eighth and ninth hexadecimal pairs. An example UUID looks like this:

```
00 11 22 33 44 55 66 77-88 99 aa bb cc dd ee ff
```

The UUID is based on the physical computer's identifier and the path to the virtual machine's configuration file. This UUID is generated when you power on or reset the virtual machine. As long as you do not move or copy the virtual machine to another location, the UUID remains constant.

## The UUID and Moving Virtual Machines

When you power on a virtual machine that was moved or copied to a new location, the following message appears:

The virtual machine's configuration file has changed its location since its last poweron. Do you want to create a new unique identifier (UUID) for the virtual machine, or keep the old one?

You have four options: Create, Keep, Always Create, Always Keep. The proper selection depends on the cause for the changed UUID.

- If you moved this virtual machine, you can choose to keep the UUID. Select **Keep**, then click **OK** to continue powering on the virtual machine.
- If you copied this virtual machine to a new location, you should create a new UUID, since the copy of the virtual machine is using the same UUID as the original virtual machine. Select **Create**, then click **OK** to continue powering on the virtual machine.
- If the original virtual machine is being used as a master copy for more virtual machines, you can choose to create a new UUID the first time you power on each copy. After you configure the virtual machine and are ready to make it a master copy, move it to a new location and power it on. When the message appears after you power on, select **Always Create**, then click **OK** to continue powering on the virtual machine. The virtual machine is set up to create a new UUID every time it is moved. Power off the virtual machine and begin using it as a master copy by copying the virtual machine files to other locations.
- If you intend to move the virtual machine numerous times and want to keep the same UUID each time the virtual machine moves, select **Always Keep** and click **OK** to continue powering on the virtual machine.

**Note:** If you want to change the Always Keep or Always Create setting, power off the virtual machine and edit its configuration file (.vmx). Delete the line that contains

```
uuid.action = "create"
```

or

```
uuid.action = "keep"
```

Suspending and resuming a virtual machine does not trigger the process that generates a UUID. Thus, the UUID in use at the time the virtual machine was suspended remains in use when the virtual machine is resumed, even if it has been copied or moved. However, the next time the virtual machine is rebooted, the message appears, so you can choose to create a new UUID or keep the existing one.

## Specifying a UUID for a Virtual Machine

In some circumstances you may want to assign a specific UUID to the virtual machine. To do this, you need to override the automatically generated UUID value. Power off the virtual machine and edit its configuration file (`.vmx`) to set the value of the UUID parameter. Use a text editor to edit the configuration file. The format for the line is:

```
uuid.bios = <uuidvalue>
```

The UUID value must be surrounded by quotation marks. A sample configuration line looks like:

```
uuid.bios = "00 11 22 33 44 55 66 77-88 99 aa bb cc dd ee ff"
```

After adding this line to the configuration file, power on the virtual machine. The new UUID is used when the virtual machine boots.

## Setting the UUID for a Virtual Machine that Is Being Moved

If you plan to move a virtual machine and want it to have the same UUID it did before the move, you must note the UUID being used before the move and add that UUID to the configuration file after the move. Follow these steps:

1. Before moving the virtual machine, examine its configuration file. You need to use a text editor. The configuration file is located in your virtual machine's directory; the file has a `.vmx` extension.
2. If the virtual machine's UUID has been set to a specific value, the configuration file has a line that begins with `uuid.bios`. Note the 128-bit hexadecimal value that follows. This is the value you should use in the new location.
3. If there is no line beginning with `uuid.bios`, look for the line that begins with `uuid.location` and note the 128-bit hexadecimal value that follows it.
4. Move the virtual machine's files to the new location.
5. Start the virtual machine, then shut it down.
6. Edit the virtual machine's configuration file to add a `uuid.bios` line, as described in [Specifying a UUID for a Virtual Machine on page 172](#). Set the value of `uuid.bios` to the value you recorded in step 2.
7. Start the virtual machine. It should now have the same UUID as it did before the move.

# Moving a VMware Workstation 5 Virtual Machine

What do you do if you have created a virtual machine using VMware Workstation and you want to move it to a different computer? Or even somewhere else on the same computer? The process is not difficult, and in most cases you can even move your virtual machine from a Windows host to a Linux host — or vice versa. If the virtual machine was created under VMware Workstation 5, follow the directions in this section.

These instructions assume that you are using a virtual disk — stored in a set of `.vmdk` files on your host computer.

**Caution:** It's always safest to make backup copies of all the files in your virtual machine's directory before you start a process like this.

This section discusses the following topics:

- [Hosts with Different Hardware on page 173](#)
- [Virtual Machines Use Relative Paths on page 174](#)
- [Preparing a Workstation 5 Virtual Machine for a Move on page 174](#)
- [Moving a Workstation 5 Virtual Machine to a New Host on page 175](#)

## Hosts with Different Hardware

If you move a virtual machine to a host with significant hardware differences, the guest operating system may no longer work correctly.

### Moving Between 64-bit and 32-bit Hosts

Moving a virtual machine from a 64-bit host to a 32-bit host can require that you recompile the kernel in your Linux guest operating system.

### Moving from a Multiprocessor Host to a Uniprocessor Host

If you move a virtual machine created in VMware ESX Server on a multiprocessor host to a uniprocessor host, the guest operating system consumes 100% of the host CPU's processing capacity, even when the guest operating system is essentially idle. To prevent this, change the setting for `numvcpus` from 2 to 1 in the virtual machine configuration `.vmx` file.

## Virtual Machines Use Relative Paths

The path names for all files associated with a VMware Workstation 5 virtual machine are relative, meaning the path to each file is relative to the currently active directory. For example, if you are in the virtual machine's directory, the relative path to the virtual disk file is `<machine name>.vmdk`.

## Preparing a Workstation 5 Virtual Machine for a Move

1. Shut down the guest operating system and power off the virtual machine. If the virtual machine is suspended, resume it, then shut down the guest operating system.
2. Do one of the following:
  - If you are moving the virtual machine to a new host and have a network connection between the original host machine and the new host, you are finished with the preparations on the original host.

Otherwise, you need to have a way of moving the virtual disk (`.vmdk`) files from the virtual machine's directory to the new host. You could move them to a shared network directory, for example, or burn them to CD-ROMs if they are not too large.

Once you know how you are going to move the virtual machine, go to [Moving a Workstation 5 Virtual Machine to a New Host on page 175](#).

- If you are moving this virtual machine to another directory on this host, then you are ready to make the move. Copy all the files in the virtual machine's original directory to the new location.

If you stored any files in directories other than the virtual machine directory, be sure to move them into a directory of the same name and same position relative to the location of the virtual machine.

Start VMware Workstation and open the new virtual machine you just created. Choose **File > Open**, then browse to the virtual machine's configuration (`.vmx`) file.

## **Moving a Workstation 5 Virtual Machine to a New Host**

1. Make sure VMware Workstation is installed and working correctly on the new host computer.
2. Create a directory for the virtual machine you are moving. Locate the virtual disk files you are moving and copy them into the new directory. Be sure to copy all the files in the virtual machine's original directory. If you stored any files in directories other than the virtual machine directory, be sure to move them into a directory of the same name and same position relative to the location of the virtual machine.

If, for some reason, you are not moving a file, make sure you do not have any paths pointing to that file. Use the virtual machine settings editor and check to see if your virtual machine is pointing to the correct location for files you do not move. In the virtual machine settings editor, select each device and be sure that any devices with associated files are pointed to the correct files. Also, check the Options tab to be sure the location for the redo-log file is correct.

**Note:** If you have taken a snapshot of the virtual machine, be sure to move all files in the virtual machine's directory.

3. Start VMware Workstation and open the virtual machine you just moved. Choose **File > Open**, then browse to the virtual machine's configuration (`.vmx`) file.

See [What Files Make Up a Virtual Machine?](#) on page 96 for a description of the files that you are moving.

# Moving a VMware Workstation 4 Virtual Machine

**Note:** This section discusses virtual machines created with Workstation 4. However, the discussion applies equally to virtual machines created with all these VMware products:

- Workstation 4.x
- GSX Server 3.x
- ESX Server 2.x
- VMware ACE 1.x, 1.0.x

See [Legacy Virtual Disks on page 246](#) for more information on virtual machine formats from older VMware products.

If you want to move a virtual machine created with Workstation 4, you may prefer to upgrade it for full compatibility with VMware Workstation 5 before moving it. To do so, power on the virtual machine under VMware Workstation 5 and choose **VM > Upgrade Virtual Machine**. You can then follow the instructions in [Moving a VMware Workstation 5 Virtual Machine on page 173](#).

If you upgrade the virtual machine, you can no longer run it under VMware Workstation 4. If you need to run the virtual machine under both VMware Workstation 4 and VMware Workstation 5, do not upgrade the virtual machine. Follow the instructions in this section.

These instructions assume that you are using a virtual disk — stored in a set of `.vmdk` files on your host computer.

**Caution:** It's always safest to make backup copies of all the files in your virtual machine's directory before you start a process like this.

This section discusses the following topics regarding moving a Workstation 4 virtual machine:

- [Preparing Your Workstation 4 Virtual Machine for the Move on page 177](#)
- [Moving a Workstation 4 Virtual Machine to a New Host Machine on page 178](#)



## Preparing Your Workstation 4 Virtual Machine for the Move

1. Use VMware Workstation 4 to open the virtual machine.
2. Be sure the guest operating system is completely shut down. If the virtual machine is suspended, resume it, then shut down the guest operating system.
3. Do one of the following:
  - If you are moving the virtual machine to a new host and have a network connection between the original host machine and the new host, you are finished with the preparations on the original host. Otherwise, you need to have a way of moving the virtual disk (.vmdk) files from the virtual machine's directory to the new host. You could move them to a shared network directory, for example, or burn them to CD-ROMs if they are not too large.  
  
Once you know how you are going to move the virtual machine, go to [Moving a Workstation 4 Virtual Machine to a New Host Machine on page 178](#).
  - If you are moving this virtual machine to another directory on the same host, you are ready to make the move. Copy all the files in the virtual machine's original directory to the new location. If you stored any files in directories other than the virtual machine directory, be sure to move them into a directory of the same name and same position relative to the location of the virtual machine.
4. Start VMware Workstation 5 and open the virtual machine you just moved. Choose **File > Open**, then browse to the virtual machine's configuration (.vmtx) file.

## Moving a Workstation 4 Virtual Machine to a New Host Machine

1. Make sure VMware Workstation 5 is installed and working correctly on the new host computer.
2. Locate the virtual disk files you are moving and copy them into the new virtual machine directory. Be sure to copy all the files in the virtual machine's original directory. If you stored any files in directories other than the virtual machine directory, be sure to move them into a directory of the same name and same position relative to the location of the virtual machine.

If, for some reason, you are not moving a file, make sure you do not have any relative or absolute paths pointing to that file. Use the virtual machine settings editor and check to see if your virtual machine is pointing to the correct location for files you do not move. In the virtual machine settings editor, select each device and be sure that any devices with associated files are pointed to the correct files. Also, check the Options tab to be sure the location for the redo-log file is correct.

In addition, if you have any absolute paths pointing to any files you are moving, change them to relative paths.

3. Start VMware Workstation 5 and open the virtual machine you just moved. Choose **File > Open**, then browse to the virtual machine's configuration (.vmtx) file.

# Moving an Older Virtual Machine

This section describes the following topics

- [Moving VMware Workstation 3.0 Virtual Machines on page 179](#)
- [Moving VMware Workstation 2.x Virtual Machines on page 181](#)
- [Considerations for Moving Workstation Disks in Undoable Mode on page 182](#)

## Moving VMware Workstation 3.0 Virtual Machines

If you have created a virtual machine using VMware Workstation 3.0, or another VMware product, and you want to move it to a different computer or to another directory on your host, you need to perform the tasks outlined in this section.

These instructions assume that you are using a virtual disk — stored in a set of `.vmdk` files on your host computer.

**Caution:** It's always safest to make backup copies of all the files in your virtual machine's directory before you start a process like this.

This section discusses the following topics regarding moving a Workstation 3 virtual machine:

- [Preparing Your Workstation 3 Virtual Machine for the Move on page 180](#)
- [Preparing the Workstation 5 Host Machine for a Workstation 3 Virtual Machine on page 181](#)

### Preparing Your Workstation 3 Virtual Machine for the Move

1. Use VMware Workstation 3 to open the virtual machine. If the virtual machine has more than one virtual disk and if the virtual disks use different disk modes, you must use the Virtual Machine Control Panel to change one or more of the virtual disks so they all use the same mode.
2. Be sure you know whether the virtual disk is set up as an IDE disk or a SCSI disk. You can check this in the Virtual Machine Control Panel.  
  
Also, note the size of the virtual disk you are moving. You need this information when you prepare the new host machine, as described in the next section.
3. Be sure the guest operating system is completely shut down. If the virtual machine is suspended, resume it using the VMware product with which you created the virtual machine, then shut down the guest operating system.

**Note:** Do not move a suspended virtual machine from one host to another.

4. If your virtual machine is using disks in undoable mode, it is best to commit or discard the changes when the guest operating system shuts down. If you cannot commit or discard the changes to your disk, read [Considerations for Moving Workstation Disks in Undoable Mode on page 182](#).
5. If you have a network connection between the original host machine and the new host, you are finished with the preparations on the original host. Otherwise, you need to have a way of moving the virtual disk (.vmdk) files from the virtual machine's directory to the new host. You could move them to a shared network directory, for example, or burn them to CD-ROMs if they are not too large.

**Note:** If your disks are using undoable mode and you have not committed or discarded your changes, you must also move the redo-log (.redo) files to the new host computer.

### Preparing the Workstation 5 Host Machine for a Workstation 3 Virtual Machine

1. Make sure VMware Workstation 5 is installed and working correctly on the new host computer.
2. Run the New Virtual Machine Wizard and select the appropriate guest operating system for the virtual machine you are moving.
  - Choose a virtual disk for your hard drive and use a drive size and type (IDE or SCSI) that matches the size and type of the virtual disk you plan to move.
  - Select all appropriate network, floppy and CD-ROM settings. Do not make any changes in the virtual machine settings editor at this point.
  - Save your settings and close VMware Workstation.
3. In the directory just created for the new virtual machine, delete the brand new `.vmdk` files that were just created.
4. Locate the virtual disk files you are moving and copy them into the new virtual machine directory.

**Note:** If your virtual machine is using disks in undoable mode and you did not commit or discard your changes before the move, you must also move the redo-log (`.REDO`) files to the new host computer.

5. Start VMware Workstation 5 again and open the new virtual machine you just created. Choose **VM > Settings**.
6. Be sure the virtual machine is configured to use the virtual disk files you moved from the original host. You need to confirm that the new disk's settings — IDE or SCSI and the file name for the first `.vmdk` file — match those that were used on the original host machine.

The device listing for the hard drive shows whether it is SCSI or IDE. If that setting does not match the virtual disk you are moving, select the hard disk and click **Remove**. Then click **Add** and use the Add Hardware Wizard to add an IDE or SCSI disk as appropriate. To specify IDE or SCSI, when you reach the Disk File screen in the wizard, click the **Advanced** button.

Be sure the filename and path for the virtual disk match the actual filename and location for the first `.vmdk` file used by the virtual machine you are moving.

### Moving VMware Workstation 2.x Virtual Machines

If you have created a virtual machine using VMware Workstation 2.x, you must upgrade it under VMware Workstation 3 or 4. VMware Workstation 5 does not support VMware Workstation 2 virtual machines.

## Considerations for Moving Workstation Disks in Undoable Mode

Once you commit or discard changes made to a disk in undoable mode, you can move your disk between Linux and Windows host operating systems. You can also move your disk to different locations on your computer and to other computers with the same host operating system.

However, if you cannot or do not want to commit or discard the changes made to your undoable disk, note the following:

- You can always move a disk in undoable mode between host operating systems of the same general type (for example, between two Microsoft Windows systems, or between two Linux systems). Depending upon how the disk was first set up, you may have to place the disk and its redo log in a directory that has a path name identical to that of the current directory.
- You may be able to move the disk in undoable mode between Windows and Linux host systems, or move the disk to a different directory on your current system, if there is no path name information in the virtual machine's configuration file. This is true for virtual machines created under VMware Workstation 3.1 or higher; however, virtual machines created with older versions of Workstation contain full path names.

Follow these steps to check the configuration and see whether or not you can move your undoable disk without committing or discarding changes:

1. Start VMware Workstation 3.  
If you are moving a disk in undoable mode from one computer to another computer, start VMware Workstation 3 on the computer that currently has your disk.
2. Open the configuration file for the virtual machine that uses the undoable mode disk you wish to move.  
In the VMware Workstation window, select **File > Open** and choose the configuration file of the virtual machine with the disk you want to move.
3. Open the Virtual Machine Control Panel.

4. Examine the entry for your virtual disk to see whether it includes a full path to the first virtual disk file. For example, on a Windows host, you might see a disk file listing like this:

```
My Documents\My Virtual Machines\Windows Me\Windows Me.vmdk
```

Entries for SCSI disks are similar.

If your disk file information resembles the example above (with a full path to the first disk file) and you have not committed or discarded changes to the undoable disk, the following rules apply:

- You can move the disk to another computer of the same type (Windows to Windows or Linux to Linux).
- You must place the virtual machine's other files (including `.vmtx` and `.REDO` on Windows, `.vmtx` or `.cfg` and `.REDO` on Linux) in the same relative location on the new computer. In other words, if the virtual machine's files reside in

```
My Documents\My Virtual Machines\Windows Me\
```

on the original host computer, you must place them in that same location on the new host computer.

- You cannot move the disk to a computer of a different type (Windows to Linux or vice versa).
- You cannot move the disk to another directory on the current system.

If your disk file information does not contain a path, it looks like this:

```
Windows Me.vmdk
```

If your disk entry resembles the one above (just a filename with a `.vmdk` extension), you can move the disk and redo log anywhere you wish.

# Sharing Virtual Machines with Other Users

If other users access your virtual machines, you should consider the following points:

- On Windows hosts, the virtual machine files should be relocated to a directory that is accessible to all appropriate users. The default location for a Windows host is not typically accessible to other users:

```
C:\Documents and Settings\\My Documents\My Virtual  
Machines
```

When you configure the virtual machine in the New Virtual Machine Wizard, you can specify a location for the virtual machine elsewhere on your system or on a network volume.

- On Linux hosts, permissions for the virtual machine files — especially the configuration file (`.vmtx`) and virtual disks (`.vmdk`) — should be set for other users according to how you want them to use the virtual machine.

For example, if you want users to run a virtual machine but not be able to modify its configuration, do not make the configuration file writable.

Other users can also share a virtual machine by making a linked clone of it— a copy that uses the same virtual disks as the parent virtual machine it was copied from. See [Cloning a Virtual Machine on page 267](#)



## **Moving Linked Clones**

You can move a linked clone as you would an ordinary Workstation 5 virtual machine. However, if you move a linked clone (or if you move its parent virtual machine), make certain the clone can access the parent virtual machine, for example using a shared directory or networked file server.

When you power on a linked clone that has been moved, be prepared to update the file system path to the parent virtual machine location.

**Caution:** You cannot power on a linked clone if Workstation cannot locate the original virtual machine.



# 8

CHAPTER

## Using Disks

---

The following sections provide information on configuring your virtual machine's hard disk storage so it best meets your needs:

- [Configuring Hard Disk Storage in a Virtual Machine on page 188](#)
- [Adding Drives to a Virtual Machine on page 197](#)
- [Using VMware Virtual Disk Manager on page 208](#)
- [Configuring a Dual-Boot Computer for Use with a Virtual Machine on page 215](#)
- [Installing an Operating System onto a Physical Partition from a Virtual Machine on page 241](#)
- [Legacy Virtual Disks on page 246](#)

# Configuring Hard Disk Storage in a Virtual Machine

Like a physical computer, a VMware Workstation virtual machine stores its operating system, programs and data files on one or more hard disks. Unlike a physical computer, VMware Workstation gives you options for undoing changes to the virtual machine's hard disk.

The New Virtual Machine Wizard creates a virtual machine with one disk drive. You can use the virtual machine settings editor (**VM > Settings**) to add more disk drives to your virtual machine, to remove disk drives from your virtual machine or to change certain settings for the existing disk drives.

This section describes the choices you can make in setting up hard disk storage for your virtual machine.

- [Disk Types: Virtual and Physical on page 188](#)
- [Adding a New Virtual Disk to a Virtual Machine on page 197](#)
- [Defragmenting Virtual Disks on page 193](#)
- [Shrinking Virtual Disks on page 193](#)

## Disk Types: Virtual and Physical

In the most common configurations, VMware Workstation creates virtual hard disks, which are made up of files that are typically stored on your host computer's hard disk. In some circumstances, you may need to give your virtual machine direct access to a physical hard drive on your host computer.

- [Virtual Disk on page 188](#)
- [Physical Disk on page 190](#)

### Virtual Disk

A virtual disk is a file or set of files that appears as a physical disk drive to a guest operating system. The files can be on the host machine or on a remote computer. When you configure a virtual machine with a virtual disk, you can install a new operating system onto the virtual disk without repartitioning a physical disk or rebooting the host.

Virtual disks can be as large as 950GB (IDE or SCSI). Depending on the size of the virtual disk and the host operating system, VMware Workstation creates one or more files to hold each virtual disk.

By default, the actual files used by the virtual disk start out small and grow to their maximum size as needed. The main advantage of this approach is the smaller file size.

Smaller files require less storage space and are easier to move if you want to move the virtual machine to a new location. However, it takes longer to write data to a disk configured in this way.

You may also configure virtual disks so all the disk space is allocated at the time the virtual disk is created. This approach provides enhanced performance and is useful if you are running performance-sensitive applications in the virtual machine.

Virtual disks can be set up as IDE disks for any guest operating system. They can be set up as SCSI disks for any guest operating system that has a driver for the LSI Logic or BusLogic SCSI adapter available in a VMware Workstation virtual machine. You determine which SCSI adapter to use at the time you create the virtual machine.

**Note:** To use SCSI disks in a Windows XP or Windows Server 2003 virtual machine, you need a special SCSI driver available from the download section of the VMware Web site at [www.vmware.com/download](http://www.vmware.com/download). Follow the instructions on the Web site to use the driver with a fresh installation of Windows XP or Windows Server 2003.

A virtual disk of either type can be stored on either type of physical hard disk. That is, the files that make up an IDE virtual disk can be stored on either an IDE hard disk or a SCSI hard disk. So can the files that make up a SCSI virtual disk. They can also be stored on other types of fast-access storage media, such as DVD or CD-ROM discs.

A key advantage of virtual disks is their portability. Because the virtual disks are stored as files on the host machine or a remote computer, you can move them easily to a new location on the same computer or to a different computer. You can also use VMware Workstation on a Windows host to create virtual disks, then move them to a Linux computer and use them under VMware Workstation for Linux — or vice versa. For information about moving virtual disks, see [Moving and Sharing Virtual Machines on page 169](#).

## Physical Disk

A physical disk directly accesses an existing local disk or partition. You can use physical disks if you want VMware Workstation to run one or more guest operating systems from existing disk partitions. While virtual disks are limited to 950GB, physical disks may be set up on both IDE and SCSI devices of up to 2TB capacity. At this time, however, booting from an operating system already set up on an existing SCSI disk or partition is not supported.

**Caution:** If you run an operating system natively on the host computer, then switch to running it inside a virtual machine, the change is like pulling the hard drive out of one computer and installing it in a second computer with a different motherboard and other hardware. You need to prepare carefully for such a switch. The specific steps you need to take depend on the operating system you want to use inside the virtual machine. For details, see [Configuring a Dual-Boot Computer for Use with a Virtual Machine on page 215](#).

You can also create a new virtual machine using a physical disk. For details, see [Installing an Operating System onto a Physical Partition from a Virtual Machine on page 241](#). In most cases, however, it is better to use a virtual disk.

Only expert users should attempt physical disk configurations.

**Note:** You should not use a physical disk to share files between host and guest operating systems. It is not safe to make the same partition visible to both host and guest. You can cause data corruption if you do this. To share files between host and guest operating systems, use shared folders. For details, see [Using Shared Folders on page 157](#).

## Disk Files

In the virtual machine settings editor (**VM > Settings**), you can choose the disk files for a virtual machine. See [What Files Make Up a Virtual Machine? on page 96](#) for a comprehensive list of the other files.

You may want to choose a file other than the one created by the New Virtual Machine Wizard if you are using a virtual disk that you created in a different location or if you are moving the automatically created disk files to a new location.

The disk files for a virtual disk store the information that you write to a virtual machine's hard disk — the operating system, the program files and the data files. The virtual disk files have a `.vmdk` extension.

A virtual disk is made up of one or more `.vmdk` files.

On Windows hosts, each virtual disk is contained in one file by default. You may, as an option, configure the virtual disk to use a set of files limited to 2GB per file. Use this option if you plan to move the virtual disk to a file system that does not support files larger than 2GB.

You must set this option at the time the virtual disk is created.

If you are setting up a new virtual machine, in the New Virtual Machine Wizard, follow the **Custom** path. In the screen that allows you to specify the virtual disk's capacity, select **Split disk into 2GB files**.

If you are adding a virtual disk to an existing virtual machine, follow the steps in the Add Hardware Wizard. In the screen that allows you to specify the virtual disk's capacity, select **Split disk into 2GB files**.

When a disk is split into multiple files, larger virtual disks have more `.vmdk` files.

The first `.vmdk` file for each disk is small and contains pointers to the other files that make up the virtual disk. The other `.vmdk` files contain data stored by your virtual machine and use a small amount of space for virtual machine overhead.

If you chose to allocate space for the virtual disk in advance, the file sizes are fixed, and most of the files are 2GB. As mentioned above, the first file is small. The last file in the series may also be smaller than 2GB.

If you did not allocate the space in advance, the `.vmdk` files grow as data is added, to a maximum of 2GB each — except for the first file in the set, which remains small.

The virtual machine settings editor shows the name of the first file in the set — the one that contains pointers to the other files in the set. The other files used for that disk are automatically given names based on the first file's name.

For example, a Windows XP Professional virtual machine using the default configuration, with files that grow as needed, stores the disk in files named `Windows XP Professional.vmdk`, `Windows XP Professional-s001.vmdk`, `Windows XP Professional-s002.vmdk` and so on.

If the disk space is allocated in advance, the names are similar, except that they include an `f` instead of an `s` — for example, `Windows XP Professional-f001.vmdk`.

If you are using a physical disk, the `.vmdk` file stores information about the physical disk or partition used by the virtual machine.

## Lock Files

A running virtual machine creates lock files to prevent consistency problems on virtual disks. If the virtual machine did not use locks, multiple virtual machines might read and write to the disk, causing data corruption.

Lock files are always created in the same directory as the `.vmdk` files.

The locking methods used by VMware Workstation on Windows and Linux hosts are different, so files shared between them are not fully protected. If you use a common file repository that provides files to users on both Windows and Linux hosts, be sure that each virtual machine is run by only one user at a time.

When a virtual machine is powered off, it removes the lock files it created. If it cannot remove the lock, a stale lock file is left protecting the `.vmdk` file. For example, if the host machine crashes before the virtual machine has a chance to remove its lock file, a stale lock remains.

If a stale lock file remains when the virtual machine is started again, the virtual machine tries to remove the stale lock. To make sure that no virtual machine could be using the lock file, the virtual machine checks the lock file to see if

1. The lock was created on the same host where the virtual machine is running.
2. The process that created the lock is not running.

If those two conditions are true, the virtual machine can safely remove the stale lock. If either of those conditions is not true, a dialog box appears, warning you that the virtual machine cannot be powered on. If you are sure it is safe to do so, you may delete the lock files manually. On Windows hosts, the filenames of the lock files end in `.lck`. On Linux hosts, the filenames of the lock files end in `.WRITELOCK`.

Physical disk partitions are also protected by locks. However, the host operating system is not aware of this locking convention and thus does not respect it. For this



reason, VMware strongly recommends that the physical disk for a virtual machine not be installed on the same physical disk as the host operating system.

## Defragmenting Virtual Disks

Like physical disk drives, virtual disks can become fragmented. Defragmenting disks rearranges files, programs, and unused space on the virtual disk so that programs run faster and files open more quickly. Defragmenting does not reclaim unused space on a virtual disk; to reclaim unused space, shrink the disk.

For best disk performance, follow these steps:

1. Run a disk defragmentation utility inside the virtual machine.
2. Power off the virtual machine, then defragment its virtual disks from the virtual machine settings editor (**VM > Settings**). Select the virtual disk you want to defragment, then click **Defragment**.

**Note:** This capability works only with virtual disks, not physical or plain disks.

3. Run a disk defragmentation utility on the host computer

Defragmenting disks may take considerable time.

**Note:** The defragmentation process requires free working space on the host computer's disk. If your virtual disk is contained in a single file, for example, you need free space equal to the size of the virtual disk file. Other virtual disk configurations require less free space.

## Shrinking Virtual Disks

If you have a virtual disk that grows as data is added, you can shrink it as described in this section. If you allocated all the space for your virtual disk at the time you created it, you cannot shrink it.

**Note:** The maximum benefit occurs when you defragment a virtual disk before you shrink it. See [Defragmenting Virtual Disks on page 193](#).

Shrinking a virtual disk reclaims unused space in the virtual disk. If there is empty space in the disk, this process reduces the amount of space the virtual disk occupies on the host drive.

Shrinking a virtual disk is a convenient way to convert a virtual disk to the format supported by Workstation. Virtual disks created in the new format can be recognized only by VMware Workstation 3.0 and higher.

This section describes the following topics:

- [Restrictions and Requirements on page 194](#)

- [The Shrinking Process on page 194](#)
- [Unsupported and Disabled Partitions on page 196](#)

### Restrictions and Requirements

Shrinking requires free disk space on the host equal to the size of the virtual disk you are shrinking.

Shrinking applies only to virtual disks. You cannot shrink physical disks or CD-ROMs.

The shrink feature is not enabled if the virtual machine

- Contains a snapshot
- Is a parent of a linked clone
- Is a linked clone

The shrink feature is not enabled for a virtual machine if any of its virtual disks are

- Preallocated when created
- Not used in independent-persistent mode
- Legacy disks that are not in persistent mode
- Booted as independent disks

**Note:** You can change the mode of a virtual disk before the virtual machine is powered on. See [Excluding Disks from Snapshots on page 256](#) for a discussion of independent disks.

### The Shrinking Process

Shrinking a disk is a two-step process:

- In the first step, called wiping, VMware Tools reclaims all unused portions of disk partitions (such as deleted files) and prepares them for shrinking. Wiping takes place in the guest operating system.
- The second step is the shrinking process itself, which takes place on the host. Workstation reduces the size of the disk's files by the amount of disk space reclaimed in the wipe process.

When a virtual machine is powered on, you shrink its virtual disks from the VMware Tools control panel. You cannot shrink virtual disks if a snapshot exists. To remove the snapshot if one exists, choose **VM > Snapshot > Snapshot Manager > Delete**. See [Unsupported and Disabled Partitions on page 196](#).

In a Linux or FreeBSD guest operating system, to prepare virtual disks for shrinking, you should run VMware Tools as the root user. This way, you ensure the whole virtual

disk is shrunk. Otherwise, if you shrink disks as a nonroot user you cannot wipe the parts of the virtual disk that require root-level permissions.

To shrink a virtual disk:

1. Launch the control panel.
  - **Windows guest** — double-click the VMware Tools icon in the system tray, or choose **Start > Settings > Control Panel**, then double-click **VMware Tools**.
  - **Linux or FreeBSD guest** — become root (`su -`), then run `vmware-toolbox`.
2. Click the **Shrink** tab.

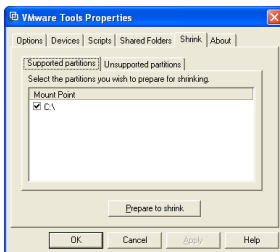

3. Select the virtual disks you want to shrink, then click **Prepare to Shrink**.

A dialog box tracks the progress of the wiping process.

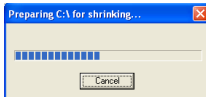

**Note:** If you deselect some partitions, the whole disk is still shrunk. However, those partitions are not wiped for shrinking, and the shrink process does not reduce the size of the virtual disk as much as it could with all partitions selected.

4. Click **Yes** when VMware Tools finishes wiping the selected disk partitions.

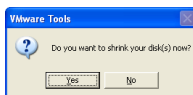

A dialog box tracks the progress of the shrinking process. Shrinking disks may take considerable time.

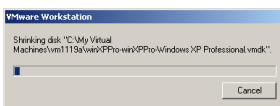

- Click **OK** to finish.



### Unsupported and Disabled Partitions

In some configurations, it is not possible to shrink virtual disks. If your virtual machine uses such a configuration, the Shrink tab displays information explaining why you cannot shrink your virtual disks.

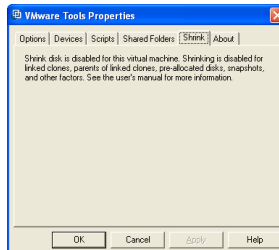
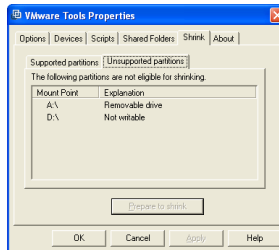

For example, you cannot shrink a virtual disk if

- You preallocated disk space when you created the disk. Preallocating disk space is the default option for both typical and custom virtual machine creation paths.
- The virtual machine has any snapshots. To delete a snapshot, choose **VM > Snapshot > Snapshot Manager > Delete**.
- The virtual machine contains physical disks.
- The virtual disk is not an independent disk in persistent mode.
- The virtual disk is stored on a CD-ROM.

## Adding Drives to a Virtual Machine

VMware Workstation virtual machines can use up to four IDE devices and up to seven SCSI devices. Any of these devices can be a virtual hard disk or DVD or CD-ROM drive. A virtual machine can read data from a DVD disc. VMware Workstation does not support playing DVD movies in a virtual machine.

Many other SCSI devices can be connected to a virtual machine using the host operating system's generic SCSI driver. For details on connecting these devices, see [Connecting to a Generic SCSI Device on page 402](#).

This section discusses the following topics:

- [Adding a New Virtual Disk to a Virtual Machine on page 197](#)
  - [Removing a Virtual Disk from a Virtual Machine on page 200](#)
- [Adding Physical Disks to a Virtual Machine on page 201](#)
- [Adding DVD or CD Drives to a Virtual Machine on page 204](#)
- [Adding Floppy Drives to a Virtual Machine on page 206](#)
- [Connecting a CD-ROM or Floppy Drive to an Image File on page 207](#)

### Adding a New Virtual Disk to a Virtual Machine

Virtual disks are stored as files on the host computer or on a network file server. It does not matter whether the physical disk that holds the files is IDE or SCSI. A virtual IDE drive can be stored on an IDE drive or on a SCSI drive. So can a virtual SCSI drive.

Use the virtual machine settings editor (**VM > Settings**) to add a new virtual disk to your virtual machine. To add an existing virtual disk to the virtual machine, see [Adding an Existing Virtual Disk to a Virtual Machine on page 199](#). The virtual machine must be powered off before you begin. If it is not, shut down the guest operating system normally, then click **Power Off** on the VMware Workstation toolbar.

**Note:** If you have a Windows NT 4.0 guest with a SCSI virtual disk, you cannot add both an additional SCSI disk and an IDE disk to the configuration.

1. Open the virtual machine settings editor (**VM > Settings**) and click **Add**. The Add Hardware Wizard guides you through the steps to create your virtual disk.

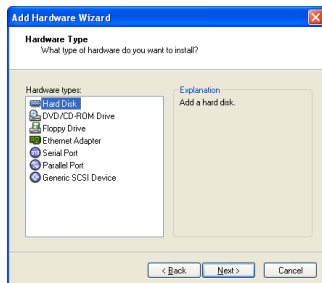

2. Click **Hard Disk**, then click **Next**.
3. Select **Create a new virtual disk**, then click **Next**.
4. Choose whether you want the virtual disk to be an IDE disk or a SCSI disk.
5. Set the capacity for the new virtual disk.

If you wish, select **Allocate all disk space now**.

Allocating all the space at the time you create the virtual disk gives somewhat better performance, but it requires as much disk space as the size you specify for the virtual disk.

If you do not select this option, the virtual disk's files start small and grow as needed, but they can never grow larger than the size you set here.

You can set a size between 0.1GB and 950GB for a virtual disk. The default is 4GB.

You may also specify whether you want the virtual disk created as one large file or split into a set of 2GB files. You should split your virtual disk if it is stored on a file system that does not support files larger than 2GB.

6. Accept the default filename and location for the virtual disk file or change it, if you want to use a different name or location. To find a different folder, click **Browse**.

If you want to specify a device node for your virtual disk, click **Advanced**.

On the advanced settings screen, you can also specify a disk mode. This is useful in certain special-purpose configurations in which you want to exclude disks from snapshots. For more information on the snapshot feature, see [Using Snapshots on page 251](#).

Normal disks are included in snapshots. In most cases, this is the setting you want — with **Independent** deselected.

Independent disks are not included in snapshots. If you select **Independent**, you have the following options:

- **Persistent** — changes are immediately and permanently written to the disk.
- **Nonpersistent** — changes to the disk are discarded when you power off or revert to a snapshot.

When you have set the filename and location you want to use and have made any selections you want to make on the advanced settings screen, click **Finish**.

7. The wizard creates the new virtual disk. It appears to your guest operating system as a new, blank hard disk. Use the guest operating system's tools to partition and format the new drive for use.

### **Adding an Existing Virtual Disk to a Virtual Machine**

You can reconnect an existing virtual disk that has been removed from a virtual machine (see [Removing a Virtual Disk from a Virtual Machine on page 200](#)). The virtual machine must be powered off before you begin.

1. Open the virtual machine settings editor (**VM > Settings**) and click **Add**. The Add Hardware Wizard guides you through the steps to create your virtual disk.
2. Click **Hard Disk**, then click **Next**.
3. Select **Use an existing virtual disk**, then click **Next**.
4. Enter the path and filename for the existing disk file, or click **Browse** to navigate to the file.
5. Click **OK**.

### Removing a Virtual Disk from a Virtual Machine

Use the virtual machine settings editor to disconnect a virtual disk from a virtual machine.

To remove a virtual disk from a virtual machine:

1. Select a virtual machine and choose **VM > Settings**.

**Note:** A virtual machine must be powered off before you can remove a virtual disk. You cannot remove a virtual disk if the virtual machine is suspended.

2. Select the virtual disk you want to remove.
3. Click **Remove**.

The virtual disk is disconnected from virtual machine.

**Note:** The **Remove** command does not delete files from the host file system. You can delete virtual disk files manually. You can also retain the virtual disk files and reconnect the virtual disk to the virtual machine later. See [Adding an Existing Virtual Disk to a Virtual Machine on page 199](#).



## Adding Physical Disks to a Virtual Machine

Use the virtual machine settings editor (**VM > Settings**) to add a new raw disk to your virtual machine. The virtual machine should be powered off before you begin. If it is not, shut down the guest operating system normally, then click **Power Off** on the VMware Workstation toolbar.

**Caution:** Physical disks are an advanced feature and should be configured only by expert users.

1. Open the virtual machine settings editor (**VM > Settings**) and click **Add**. The Add Hardware Wizard guides you through the steps to create your virtual disk.
2. Click **Hard Disk**, then click **Next**.

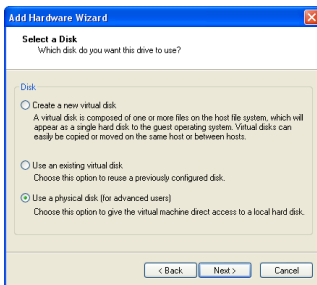

3. Select **Use a physical disk**, then click **Next**.

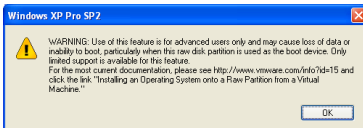

A warning appears. Click **OK**.

4. Select the physical disk characteristics and click **Next**.

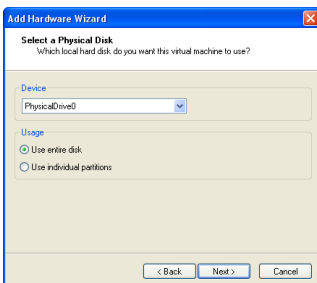

- Choose the physical hard disk to use from the drop-down list. VMware Workstation supports physical disks up to 2TB.
  - Select whether you want to use the entire disk or use only individual partitions on the disk. If you select **Use entire disk**, continue with step 6.
5. If you selected **Use entire disk** in step 4, this step does not appear.
- If you selected **Use individual partitions** in step 4, now select which partitions you want to use in the virtual machine.

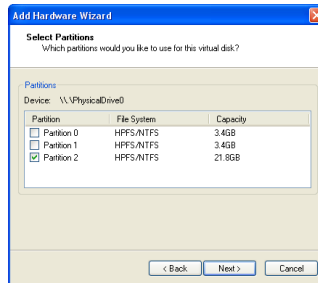

Only the partitions you select in this step are visible to the virtual machine. All other partitions are hidden from it.

Click **Next**.

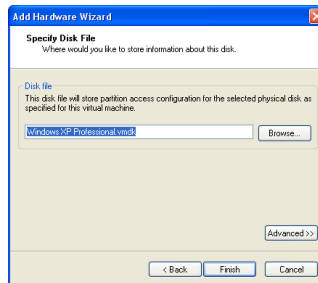

- Accept the default filename and location for the file that stores access information for this raw disk — or change it, if you want to use a different name or location. To find a different directory, click **Browse**.

Click **Advanced** if you want to specify the virtual machine SCSI or IDE device node to which this disk is connected.

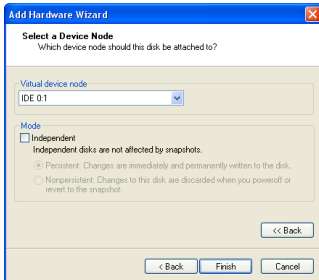

On the advanced settings screen, you can also specify a disk mode. This is useful in certain special-purpose configurations in which you want to exclude disks from a snapshot. For more information on the snapshot feature, see [Using Snapshots on page 251](#).

Normal disks are included in snapshots. In most cases, this is the setting you want — with **Independent** deselected.

Independent disks are not included in snapshots. If you select **Independent**, you have the following options:

- **Persistent** — changes are immediately and permanently written to the disk.
- **Nonpersistent** — changes to the disk are discarded when you power off or revert to a snapshot.

When you have set the filename and location you want to use and have made any selections you want to make on the advanced settings screen, click **Finish**.

- The wizard configures the new physical disk. If the partitions used on the physical disk are not formatted for your guest operating system, use the guest operating system's tools to format them.

**Caution:** After you create a physical disk using one or more partitions on a physical disk, you should never modify the partition tables by running `fdisk` or a similar utility in the guest operating system.

**Note:** If you use `fdisk` or a similar utility on the host operating system to modify the partition table of the physical disk, you must recreate the virtual machine's physical disk.

## Adding DVD or CD Drives to a Virtual Machine

You can add one or more DVD or CD drives to your virtual machine. You can connect the virtual machine's drive to a physical drive on the host machine or to an ISO image file.

You can configure the virtual DVD or CD drive as either IDE or SCSI, no matter what kind of physical drive you connect it to. In other words, if your host computer has an IDE CD drive, you can set up the virtual machine's drive as either SCSI or IDE and connect it to the host's drive. The same is true if the host's physical drive is a SCSI drive.

### Adding a DVD or CD Drive

1. Open the virtual machine settings editor (**VM > Settings**) and click **Add** to start the Add Hardware Wizard.
2. Click **DVD/CD-ROM Drive**, then click **Next**.
3. Select **Use physical drive** if you want to connect the virtual machine's drive to a physical drive on the host computer. Select **Use ISO Image** if you want to connect the virtual machine's drive to an ISO image file.
4. Do one of the following:
  - If you selected **Use physical drive**, choose the drive you want to use from the drop-down list or choose **Auto detect**.

If you do not want the CD drive connected when the virtual machine starts, deselect **Connect at power on**.

Click **Advanced** if you want to specify the device node the drive should use in the virtual machine.

On the advanced settings screen you may also select **Legacy emulation**. This is necessary only if you have had problems using normal mode. The legacy emulation mode does not support all the capabilities of normal mode. For example, if you are using legacy emulation mode, you cannot record CDs, you cannot read multisession CDs, you cannot extract digital audio from a CD and you cannot read or write DVDs. For details, see [Legacy Emulation for DVD and CD Drives on page 205](#).

After you have made any desired changes in these settings, click **Finish**.

- If you selected **Use ISO Image**, enter the path and filename for the image file or click **Browse** to navigate to the file.

If you do not want the CD drive connected when the virtual machine starts, deselect **Connect at power on**.

Click **Advanced** if you want to specify the device node the drive should use in the virtual machine.

After you have made any desired changes in these settings, click **Finish**.

5. The drive is set up initially so it appears to the guest operating system as an IDE drive. If you want it to appear to the guest operating system as a SCSI drive, click the drive's entry in the virtual machine settings editor and make that change in the settings panel on the right.

### Legacy Emulation for DVD and CD Drives

The virtual machine settings editor (**VM > Settings**) provides a **Legacy emulation** option for DVD and CD drives attached to the virtual machine.

On Windows hosts, this option is deselected by default.

On Linux hosts with IDE drives, the default setting for this option depends on whether the `ide-scsi` module is loaded in your kernel. The `ide-scsi` module must be loaded — or you must be using a physical SCSI drive — if you want to connect to the DVD or CD drive in raw mode.

If you encounter problems using your DVD or CD drive, try selecting **Legacy emulation**.

Note that in legacy emulation mode, you can read from data discs in the DVD or CD drive, but some other functions are not available.

When **Legacy emulation** is deselected, the guest operating system communicates directly with the drive. This direct communication enables capabilities that are not possible in legacy emulation mode, such as using CD and DVD writers to burn discs, reading multisession CDs, performing digital audio extraction and viewing video.

However, in some cases, the DVD or CD drive may not work correctly when the guest operating system is communicating directly with the drive. In addition, certain drives and their drivers do not work correctly in raw mode. Selecting **Legacy emulation** is a way to work around these problems.

If you run more than one virtual machine at a time, and if their CD drives are in legacy emulation mode, you may prefer to start the virtual machines with their CD drives disconnected. This ensures that you do not have multiple virtual machines connected to the CD drive at the same time.

## Adding Floppy Drives to a Virtual Machine

You can add floppy drives to your virtual machine, to a total of two floppy drives. A virtual floppy drive can connect to a physical floppy drive on the host computer, to an existing floppy image file or to a blank floppy image file.

### Adding a Floppy Drive

1. Open the virtual machine settings editor (**VM > Settings**) and click **Add** to start the Add Hardware Wizard.
2. Click **Floppy Drive**, then click **Next**.
3. Select what you want to connect to — a physical floppy drive on the host computer, an existing floppy image file or a new floppy image file. Click **Next**.
4. If you selected **Use a physical floppy drive**, choose the drive's letter (on a Windows host) or device name (on a Linux host) from the drop-down list, then click **Finish**.

If you selected **Use a floppy image**, type the path and filename for the floppy image file you want to use or click **Browse** to navigate to the file. Click **Finish**.

If you selected **Create a blank floppy image**, use the default path and filename or type in a new one. To navigate to a location, click **Browse**. When the field contains the path and filename you want to use for the new floppy image file, click **Finish**.

**Note:** By default, only one floppy drive is enabled in the virtual machine's BIOS. If you are adding a second floppy drive to the virtual machine, click inside the virtual machine window and press F2 as the virtual machine boots to enter the BIOS setup utility. On the main screen, choose **Legacy Diskette B:** and use the plus (+) and minus (-) keys on the numerical keypad to select the type of floppy drive you want to use. Then press F10 to save your changes and close the BIOS setup utility.

## Connecting a CD-ROM or Floppy Drive to an Image File

You can use the virtual machine settings editor to connect an existing virtual CD-ROM or floppy drive to an image file.

You can connect a virtual CD-ROM drive to an ISO image file.

### Connecting to an ISO Image File

1. Open the virtual machine settings editor (**VM > Settings**) and select the DVD/CD-ROM drive you want to connect to the image file.
2. Select **Use ISO Image** and enter the path and filename for the image file or click **Browse** to navigate to the file.
3. Click **OK** to save the configuration and close the virtual machine settings editor.

### Connecting to a Floppy Image File

1. Open the virtual machine settings editor (**VM > Settings**) and select the floppy drive you want to connect to an image file.
2. Type the path and filename for the floppy image file you want to use or click **Browse** to navigate to the file.

If you want to create a new image file, click **Create**. Use the default filename and folder or change them as you wish.

3. Click **Finish**.

## Using VMware Virtual Disk Manager

VMware Virtual Disk Manager is a utility in VMware Workstation that allows you to create, manage and modify virtual disk files from the command line or within scripts.

One key feature is the ability to enlarge a virtual disk so its maximum capacity is larger than it was when you created it. This way, if you find you need more disk space in a given virtual machine, but you do not want to add another virtual disk or use ghosting software to transfer the data on a virtual disk to a larger virtual disk, you can instead change the maximum size of the virtual disk. This is something you cannot do with physical hard drives.

Another feature allows you to change disk types. When you create a virtual machine, you specify how disk space is allocated. You select one of the following:

- All space for the virtual disk is allocated in advance. This corresponds to what the virtual disk manager calls the preallocated disk type.
- Space allocated for the virtual disk begins small and grows as needed. This corresponds to what the virtual disk manager calls the growable disk type.

With virtual disk manager you can change whether the virtual disk type is preallocated or growable and whether the virtual disk is stored in a single file or split into 2GB files. For example, you may have allocated all the disk space for a virtual disk, then find that you need to reclaim some hard disk space on the host. You can convert the preallocated virtual disk into a growable disk, then remove the original virtual disk file. The new virtual disk is large enough to contain all the data in the original virtual disk. The virtual disk grows in size as you add data to it.

These features and the ability to use scripting to automate management of virtual disks were added to VMware Workstation in version 5.0.

You can use the virtual disk manager for the following tasks:

- Automate the management of virtual disks with scripts.
- Create virtual disks that are not associated with a particular virtual machine, for example to be used as templates.
- Switch the virtual disk type from preallocated to growable, or vice versa. When you change the disk type to growable, you reclaim some disk space. You can shrink the virtual disk to reclaim even more disk space.



- Expand the size of a virtual disk so it is larger than the size specified when you created it.
- Defragment virtual disks.
- Prepare and shrink virtual disks without powering on the virtual machine (Windows hosts only).

You can use the virtual disk manager with virtual disks created under VMware GSX Server, VMware Workstation and VMware VirtualCenter (provided the virtual disk was created on a GSX Server host managed by VirtualCenter).

**Note:** You cannot use the virtual disk manager to create physical disks. Physical disks cannot be shrunk by the virtual disk manager or by Workstation.

For more information about using the virtual disk manager, read the following sections:

- [Running the VMware Virtual Disk Manager Utility on page 209](#)
- [Shrinking Virtual Disks with VMware Virtual Disk Manager on page 212](#)
- [Examples Using the VMware Virtual Disk Manager on page 213](#)

## Running the VMware Virtual Disk Manager Utility

To run the VMware Virtual Disk Manager utility, open a command prompt or terminal on the host operating system. On a Windows host, change to the directory where you installed your Workstation software. By default, this directory is `C:\Program Files\VMware\VMware Workstation`.

The command syntax is:

```
vmware-vdiskmanager [options]
```

The options you can or must use include the following:

Options and Parameters	Description
<diskname>	The name of the virtual disk file. The virtual disk file must have a .vmdk extension.  You can specify a path to the folder where you want to store the disk files. If you mapped a network share on your host operating system, you can create the virtual disk on that share by providing the correct path information with the disk file name.
-c	Creates the virtual disk. You must use the -a, -s and -t options, and you must specify the name of the virtual disk (<diskname>).

Options and Parameters	Description
<p><code>-r</code>  <code>&lt;sourcefilename&gt;</code></p>	<p>Converts the specified virtual disk, creating a new virtual disk as a result. You must use the <code>-t</code> option to specify the disk type to which the virtual disk is converted and you must specify the name of the target virtual disk (<code>&lt;targetfilename&gt;</code>).</p> <p>Once the conversion is completed and you have tested the converted virtual disk to make sure it works as expected, you can delete the original virtual disk file.</p> <p>In order for the virtual machine to recognize the converted virtual disk, you should use the virtual machine settings editor to remove the existing virtual disk from the virtual machine, then add the converted disk to the virtual machine. For information on adding virtual disks to a virtual machine, see <a href="#">Adding Drives to a Virtual Machine on page 197</a>.</p>
<p><code>-x &lt;n&gt; [GB   MB]</code>  <code>&lt;diskname&gt;</code></p>	<p>Expands the virtual disk to the specified capacity. You must specify the new, larger size of the virtual disk in gigabytes or megabytes. You cannot change the size of a physical disk.</p> <p><b>Caution:</b> Before running the virtual disk manager utility, you should back up your virtual disk files.</p>
<p><code>-d &lt;diskname&gt;</code></p>	<p>Defragments the specified virtual disk. You can defragment only growable virtual disks. You cannot defragment preallocated virtual disks.</p>
<p><code>-p &lt;mountpoint&gt;</code></p>	<p>Prepares a virtual disk for shrinking. If the virtual disk is partitioned into volumes, each volume must be prepared separately. The volume (C: or D:, for example) must be mounted by VMware DiskMount at <code>&lt;mountpoint&gt;</code>. For information on mounting and unmounting virtual disk volumes with DiskMount, see the VMware DiskMount user's manual, available from the VMware Web site at <a href="http://www.vmware.com/pdf/VMwareDiskMount.pdf">www.vmware.com/pdf/VMwareDiskMount.pdf</a>. The VMware DiskMount Utility is available as a free download at <a href="http://www.vmware.com/download/diskmount.html">www.vmware.com/download/diskmount.html</a>.</p> <p>After you prepare the volume, unmount it with VMware DiskMount. Continue mounting each volume of the virtual disk and preparing it for shrinking until you complete this process for all the volumes of the virtual disk.</p> <p>You can mount only one volume of a virtual disk at a time with VMware DiskMount. You can prepare volumes of virtual disks for shrinking on Windows hosts only.</p>

Options and Parameters	Description
-k <diskname>	<p>Shrinks the specified virtual disk. You can shrink only growable virtual disks. You can shrink virtual disks on Windows hosts only.</p> <p>You cannot shrink a virtual disk if the virtual machine has a snapshot. To keep the virtual disk in its current state, use the snapshot manager to delete all snapshots. To discard changes made since you took the snapshot, revert to the snapshot.</p>
-a [ide buslogic lsilogic]	<p>Specifies the disk adapter type. You must specify an adapter type when creating a new virtual disk. Choose one of the following types:</p> <ul style="list-style-type: none"> <li>• <b>ide</b> — for an IDE adapter.</li> <li>• <b>buslogic</b> — for a BusLogic SCSI adapter.</li> <li>• <b>lsilogic</b> — for an LSI Logic SCSI adapter.</li> </ul>
-s <n> [GB MB]	<p>Specifies the size of the virtual disk. Specify whether the size &lt;n&gt; is in GB (gigabytes) or MB (megabytes). You must specify the size of a virtual disk when you create it.</p> <p>Even though you must specify the size of a virtual disk when you expand it, you do not use the <b>-s</b> option.</p>
-t [0 1 2 3]	<p>You must specify the type of virtual disk when you create a new one or reconfigure an existing one. Specify one of the following disk types:</p> <p>0 — to create a growable virtual disk contained in a single virtual disk file</p> <p>1 — to create a growable virtual disk split into 2GB files</p> <p>2 — to create a preallocated virtual disk contained in a single virtual disk file</p> <p>3 — to create a preallocated virtual disk split into 2GB files</p>
-q	<p>Disables virtual disk manager logging.</p> <p>If you keep logging enabled, messages generated by the virtual disk manager are stored in a log file. The name and location of the log file appear in the command prompt or terminal window after the virtual disk manager command is run.</p>

## Shrinking Virtual Disks with VMware Virtual Disk Manager

On a Windows host, you can use the virtual disk manager to prepare and shrink virtual disks. You cannot use the virtual disk manager to prepare or shrink virtual disks located on a Linux host. You cannot use the virtual disk manager to shrink physical disks. Shrinking a virtual disk does not reduce the maximum capacity of the virtual disk itself. For more information about shrinking, see [Shrinking Virtual Disks on page 193](#).

**Caution:** You cannot shrink a virtual disk if the virtual machine has snapshots. To keep the virtual disk in its current state, use the snapshot manager to delete all snapshots. To discard changes made since you took a snapshot, revert to the snapshot.

You must prepare each volume of the virtual disk (drive C: or D:, for example) for shrinking before you can shrink the disk. To prepare a volume for shrinking, you must first mount it. To mount the volume, use the VMware DiskMount Utility, available as a free download from the VMware Web site. Go to [www.vmware.com/download/diskmount.html](http://www.vmware.com/download/diskmount.html).

The VMware DiskMount user's manual is available from the VMware Web site at [www.vmware.com/pdf/VMwareDiskMount.pdf](http://www.vmware.com/pdf/VMwareDiskMount.pdf). It contains instructions on mounting and unmounting virtual disk volumes with DiskMount.

VMware DiskMount mounts individual volumes of a virtual disk. For the best results when you shrink a virtual disk, you should mount all the volumes and prepare them for shrinking.

After you mount a virtual disk volume, use the virtual disk manager to prepare the volume for shrinking. Once you prepare a volume, unmount it, then repeat the process for each volume of the virtual disk. After you prepare all the volumes of the virtual disk, you can shrink the virtual disk. For examples, see [Preparing a Virtual Disk for Shrinking on page 214](#) and [Shrinking a Virtual Disk on page 214](#).

## Examples Using the VMware Virtual Disk Manager

The following examples illustrate how to use the virtual disk manager. You run the virtual disk manager from a command prompt.

### Creating a Virtual Disk

To create a new virtual disk, use a command like the following:

```
vmware-vdiskmanager -c -t 0 -s 40GB -a ide myDisk.vmdk
```

This creates a 40GB IDE virtual disk named `myDisk.vmdk`. The virtual disk is contained in a single `.vmdk` file. The disk space is not preallocated.

### Converting a Virtual Disk

To convert a virtual disk from preallocated to growable, use a command like the following:

```
vmware-vdiskmanager -r sourceDisk.vmdk -t 0 targetDisk.vmdk
```

This converts the disk from its original preallocated type to a growable virtual disk consisting of a single virtual disk file. The virtual disk space is no longer preallocated, and the virtual disk manager reclaims some disk space in the virtual disk so it is only as large as the data contained within it.

### Expand the Size of an Existing Virtual Disk

To expand the size of a virtual disk, use a command like the following:

```
vmware-vdiskmanager -x 40GB myDisk.vmdk
```

This increases the maximum capacity of the virtual disk to 40GB.

### Renaming a Virtual Disk

To rename a virtual disk, first remove it from any virtual machine that contains the disk (choose **VM > Settings > <virtualdisk>**, then click **Remove**).

Then use the following:

```
vmware-vdiskmanager -n myDisk.vmdk myNewDisk.vmdk
```

To rename the disk and locate it in a different directory, use:

```
vmware-vdiskmanager -n myDisk.vmdk ..\<new-path>\myNewDisk.vmdk
```

Note: The paths used in these examples assume a Windows host.

To locate the disk in a different directory but keep the same name, use:

```
vmware-vdiskmanager -n myDisk.vmdk ..\<new-path>\myDisk.vmdk
```

After you rename or relocate the virtual disk, add it back to any virtual machines that use it. Choose **VM > Settings**, click **Add**, then follow the wizard to add this existing virtual disk.

## Defragmenting a Virtual Disk

To defragment a virtual disk, use a command like the following:

```
vmware-vdiskmanager -d myDisk.vmdk
```

Remember, you cannot defragment a virtual disk if you allocated all the disk space when you created the virtual disk. You cannot defragment a physical disk.

See [Defragmentation of Disk Drives on page 408](#) for a discussion of the performance impact of defragmenting drives.

## Preparing a Virtual Disk for Shrinking

Before you can shrink a virtual disk, you must prepare each volume on the disk (C: or D:, for example) for shrinking. To prepare a volume, it must be located on a Windows host. First you must mount the volume. To mount the volume, use the VMware DiskMount Utility, available as a free download from the VMware Web site. For information about downloading and using VMware DiskMount, see the VMware DiskMount user's manual, available from the VMware Web site at [www.vmware.com/pdf/VMwareDiskMount.pdf](http://www.vmware.com/pdf/VMwareDiskMount.pdf). The VMware DiskMount Utility is available as a free download at [www.vmware.com/download/diskmount.html](http://www.vmware.com/download/diskmount.html).

VMware DiskMount mounts individual volumes of a virtual disk. For the best results when you shrink a virtual disk, you should mount all the volumes and shrink them.

After you mount a virtual disk volume, use the virtual disk manager to prepare the disk for shrinking. To prepare the volume mounted as the M: drive for shrinking, use the following command:

```
vmware-vdiskmanager -p M:
```

Once the preparations are complete, unmount the volume. Repeat this process for each volume of the virtual disk. After you prepare all the volumes for shrinking, you can shrink the virtual disk.

## Shrinking a Virtual Disk

To shrink a virtual disk, it must be located on a Windows host. Before you can shrink the virtual disk, make sure you prepare all the volumes of the virtual disk for shrinking. Then use a command like the following:

```
vmware-vdiskmanager -k myDisk.vmdk
```

Remember, you cannot shrink a virtual disk if you allocated all the disk space when you created the virtual disk. You cannot shrink a physical disk.

If the virtual disk has any snapshots, you cannot shrink the virtual disk. You must delete all snapshots before you shrink the virtual disk.

# Configuring a Dual-Boot Computer for Use with a Virtual Machine

Many users install VMware Workstation on a dual-boot or multiple-boot computer so they can run one or more of the existing operating systems in a virtual machine. If you are doing this, you may want to use the existing installation of an operating system rather than reinstall it in a virtual machine.

To support such installations, VMware Workstation makes it possible for you to use a physical IDE disk or partition, also known as a raw disk, inside a virtual machine.

**Note:** VMware Workstation supports booting from raw disk partitions only on IDE drives. Booting guest operating systems from raw SCSI drives is not supported. For a discussion of the issues on a Linux host, see [Configuring Dual- or Multiple-Boot SCSI Systems to Run with VMware Workstation on a Linux Host on page 235](#).

Setting up a raw disk configuration for a virtual machine is more complicated than using a virtual disk. Virtual disks are recommended unless you have a specific need to run directly from a physical disk or partition.

**Caution:** Raw disks are an advanced feature and should be configured only by expert users.

This section describes the following topics

- [Using the Same Operating System in a Virtual Machine and on the Host Computer on page 216](#)
- [Before You Begin on page 217](#)
- [Configuring Dual- or Multiple-Boot Systems to Run with VMware Workstation on page 219](#)
- [Setting Up Hardware Profiles in Virtual Machines on page 225](#)
- [Running a Windows 2000, Windows XP or Windows Server 2003 Virtual Machine from an Existing Multiple-Boot Installation on page 230](#)
- [Setting Up the SVGA Video Driver for a Windows 95 Guest Operating System Booted from a Raw Disk on page 230](#)
- [Setting Up the SVGA Video Driver for Use with a Windows 98 Guest Operating System Booted from a Raw Disk on page 232](#)
- [Do Not Use Windows 2000, Windows XP and Windows Server 2003 Dynamic Disks as Raw Disks on page 234](#)

- [Configuring Dual- or Multiple-Boot SCSI Systems to Run with VMware Workstation on a Linux Host on page 235](#)
- [Known Issues and Background Information on Using SCSI Raw Disks on page 238](#)

## **Using the Same Operating System in a Virtual Machine and on the Host Computer**

You may sometimes want to run an operating system inside a virtual machine and at other times want to run that same installation of the operating system by booting the host computer directly into that operating system. If you want to use this approach, you must be aware of some special considerations

The issues arise because the virtual hardware that the operating system sees when it is running in a virtual machine is different from the physical hardware it sees when it is running directly on the host computer. It is as if you were removing the boot drive from one physical computer and running the operating system installed there in a second computer with a different motherboard, video card and other peripherals — then moving it back and forth between the two systems.

The general approach for resolving these issues is to set up profiles for each of the two operating environments — the virtual machine and the physical computer. You can then choose the appropriate profile when you start the operating system. On some hardware, however, booting a previously installed operating system within a virtual machine may not work.

Technical notes in this section document the issues most commonly encountered with various guest operating systems. Read the notes that apply to your guest operating system before you begin to set up your virtual machine.



## Before You Begin

Before you begin, be sure to read all the sections listed under the name of the operating system you intend to run as a guest in a virtual machine.

### Windows Server 2003

**Caution:** Running a Windows Server 2003 guest from a raw disk is not supported. You should not test a Windows Server 2003 raw disk configuration in a production environment.

- [Configuring Dual- or Multiple-Boot Systems to Run with VMware Workstation on page 219](#)
- [Running a Windows 2000, Windows XP or Windows Server 2003 Virtual Machine from an Existing Multiple-Boot Installation on page 230](#)
- [Do Not Use Windows 2000, Windows XP and Windows Server 2003 Dynamic Disks as Raw Disks on page 234](#)

### Windows XP

**Caution:** Running a Windows XP guest from a raw disk is not supported. You should not test a Windows XP raw disk configuration in a production environment.

- [Configuring Dual- or Multiple-Boot Systems to Run with VMware Workstation on page 219](#)
- [Running a Windows 2000, Windows XP or Windows Server 2003 Virtual Machine from an Existing Multiple-Boot Installation on page 230](#)
- [Do Not Use Windows 2000, Windows XP and Windows Server 2003 Dynamic Disks as Raw Disks on page 234](#)

### Windows 2000

- [Configuring Dual- or Multiple-Boot Systems to Run with VMware Workstation on page 219](#)
- [Running a Windows 2000, Windows XP or Windows Server 2003 Virtual Machine from an Existing Multiple-Boot Installation on page 230](#)
- [Do Not Use Windows 2000, Windows XP and Windows Server 2003 Dynamic Disks as Raw Disks on page 234](#)

### Windows NT

- [Configuring Dual- or Multiple-Boot Systems to Run with VMware Workstation on page 219](#)

**Windows 98**

- [Configuring Dual- or Multiple-Boot Systems to Run with VMware Workstation on page 219](#)
- [Setting Up the SVGA Video Driver for Use with a Windows 98 Guest Operating System Booted from a Raw Disk on page 232](#)

**Windows 95**

- [Configuring Dual- or Multiple-Boot Systems to Run with VMware Workstation on page 219](#)
- [Setting Up the SVGA Video Driver for a Windows 95 Guest Operating System Booted from a Raw Disk on page 230](#)

**SCSI Systems Using a Linux Host**

- [Configuring Dual- or Multiple-Boot SCSI Systems to Run with VMware Workstation on a Linux Host on page 235](#)

**Other Uses of Raw Disks**

It is also possible to install a guest operating system on a raw disk when you plan to use that disk only within a virtual machine. For details on setting up a such a configuration, see [Installing an Operating System onto a Physical Partition from a Virtual Machine on page 241](#).

## Configuring Dual- or Multiple-Boot Systems to Run with VMware Workstation

VMware Workstation uses description files to control access to each raw IDE device on the system. These description files contain access privilege information that controls a virtual machine's access to certain partitions on the disks. This mechanism prevents users from accidentally running the host operating system again as a guest or running a guest operating system that the virtual machine was not configured to use. The description file also prevents accidental corruption of raw disk partitions by badly behaved operating systems or applications.

Use the New Virtual Machine Wizard to configure VMware Workstation to use existing raw disk partitions. The wizard guides you through creating a configuration for a new virtual machine including configuring the raw disk description files. Typically, you rerun the wizard to create a separate configuration for each guest operating system installed on a raw partition.

If a boot manager is installed on the computer system, the boot manager runs inside the virtual machine and presents you with the choice of guest operating systems to run. You must manually choose the guest operating system that this configuration was intended to run.

This section continues with the following topics:

- [Windows 2000, Windows XP and Windows Server 2003 Dynamic Disks on page 219](#)
- [Using the LILO Boot Loader on page 220](#)
- [Configuring a Windows Host on page 220](#)
- [Configuring a Linux Host on page 222](#)

### Windows 2000, Windows XP and Windows Server 2003 Dynamic Disks

If your host is running Windows 2000, Windows XP or Windows Server 2003 and is using dynamic disks, see [Do Not Use Windows 2000, Windows XP and Windows Server 2003 Dynamic Disks as Raw Disks on page 234](#).

## Using the LILO Boot Loader

If you are using the LILO boot loader and try to boot a virtual machine from an existing raw partition, you may see `L 01 01 01 01 01 01 ...` instead of a `LILO:` prompt. This can happen regardless of the host operating system. As part of booting a physical PC or a virtual machine, the BIOS passes control to code located in the master boot record (MBR) of the boot device. LILO begins running from the MBR, and in order to finish running correctly, it needs access to the native Linux partition where the rest of LILO is located — usually the partition with the `/boot` directory. If LILO can't access the rest of itself, an error message like the one above appears.

To avoid the problem, follow the configuration steps below and be sure to select the native Linux partition where the rest of LILO is located. The next time the virtual machine tries to boot, the LILO code in the MBR should be able to access the rest of LILO and display the normal `LILO:` prompt.

## Configuring a Windows Host

Use the following steps to run a guest operating system from a raw disk.

**Note:** If you use a Windows host's IDE disk in a raw disk configuration, you must not configure it as the slave on the secondary IDE channel if the master on that channel is a CD-ROM drive.

1. If you are running a Windows guest operating system, read [Setting Up Hardware Profiles in Virtual Machines on page 225](#). You should boot the guest operating system natively on the computer and create a hardware profile for the virtual machine before proceeding.
2. Create a separate configuration for each guest operating system.

To configure a virtual machine to run from a raw disk or disk partition, start the New Virtual Machine Wizard (**File > New > Virtual Machine**) and select **Custom**.

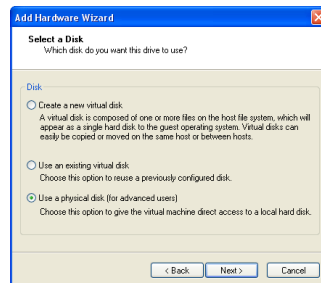

3. When you reach the Select a Disk step, select **Use a physical disk**.

4. Complete the wizard steps, specifying the appropriate disk or partition to use for this virtual machine.

**Note:** The maximum size of an IDE disk in a virtual machine is 950 GB.

5. To run multiple guest operating systems from different raw disk partitions, unmap these partitions on the host.

On a Windows NT host, use the Disk Administrator (**Start > Programs > Administrative Tools**). First highlight the partition that contains the guest operating system, then select **Assign Drive Letter** from the **Tools** menu. In this form, choose **Do not assign a drive letter** for the partition and click **OK**. The unmapping happens immediately.

On a Windows Server 2003, Windows XP or Windows 2000 host, use Disk Management (**Start > Settings > Control Panel > Administrative Tools > Computer Management > Storage > Disk Management**). Select the partition you want to unmap, then from the **Action** menu select **All Tasks > Change Drive Letter and Path**. Click the **Remove** button.

6. Use the virtual machine settings editor (**VM > Settings**) if you want to change any configuration options from the wizard defaults — for example, to change the amount of memory allocated to the guest operating system.
7. If you have multiple IDE drives configured on a system, the VMware BIOS normally attempts to boot them in this sequence:
  - a. Primary master
  - b. Primary slave
  - c. Secondary master
  - d. Secondary slave

If you have multiple SCSI drives configured on a system, the VMware BIOS normally attempts to boot them in the order of the SCSI device number.

If you have both SCSI and IDE drives configured, the VMware BIOS normally attempts to boot SCSI drives followed by IDE drives, in the order described above.

The boot sequence can be changed in the Boot menu of the virtual machine's Phoenix BIOS. After powering on the virtual machine, press F2 during the BIOS boot in the virtual machine to enter the BIOS setup menu.

8. Power on the virtual machine. Click the **Power On** button. The virtual machine starts, runs the Phoenix BIOS, then boots from the master boot record (MBR).  
Choose the target operating system from the list of options offered by the boot manager.
9. Remember that your virtual machine hardware environment, which the guest operating system is about to run in for the first time, probably differs significantly from the physical hardware of your host computer.  
For Windows guest operating systems, Plug and Play reconfigures Windows. Set up your virtual hardware profile with the devices found and configured by Plug and Play. See [Setting Up Hardware Profiles in Virtual Machines on page 225](#) for more information.
10. Install VMware Tools in your guest operating system.

**Warning:** If you take snapshots while using your raw disk, before you reboot your guest operating system natively you must either:

- Revert to a snapshot and delete all other snapshots.
- Delete all snapshots.

This is necessary because any changes to sectors on the physical disk that have been modified on the disk invalidate all snapshots for the disk.

### Configuring a Linux Host

1. If you are running a Windows guest operating system, read [Setting Up Hardware Profiles in Virtual Machines on page 225](#). You should boot the guest operating system natively on the computer and create a hardware profile for the virtual machine before proceeding.
2. Create a separate configuration for each guest operating system.
3. Check operating system partition mounts. Be sure the existing disk partitions that you plan to configure the virtual machine to use are not mounted by Linux.

4. Set the device group membership or device ownership.

The master raw disk device or devices need to be readable and writable by the user who runs VMware Workstation. On most distributions, the raw devices, such as `/dev/hda` (IDE raw disk) and `/dev/sda` (SCSI raw disk) belong to group-id `disk`. If this is the case, you can add VMware Workstation users to the `disk` group. Another option is to change the owner of the device. Please think carefully about security issues when exploring different options here.

Often, the most convenient approach is to grant VMware Workstation users access to all `/dev/hd[abcd]` raw devices that contain operating systems or boot managers and then rely on VMware Workstation's raw disk configuration files to guard access. This provides boot managers access to configuration files and other files they may need to boot the operating systems. For example, LILO needs to read `/boot` on a Linux partition to boot a non-Linux operating system that may be on another drive. As noted above, you should consider the security implications of the configuration you choose.

5. If you plan to run a second Linux installation from an existing partition as a guest operating system and your physical computer's `/etc/lilo.conf` has a memory register statement such as `Append= "mem..."`, you may want to adjust the append memory parameter or create a new entry in LILO for running Linux in a virtual machine.

If the amount of memory configured in `lilo.conf` exceeds the amount of memory assigned to the virtual machine, then when the virtual machine tries to boot the second Linux installation, the guest operating system will most likely panic.

You can create another entry in `lilo.conf` for running Linux in a virtual machine by specifying a different amount of memory than what would normally be recognized when Linux boots directly on the physical machine.

6. To configure a virtual machine to run from a raw disk partition, start the New Virtual Machine Wizard (**File > New > Virtual Machine**) and select **Custom**.
7. When you reach the Select a Disk step, select **Use a physical disk**.

8. Complete the wizard steps, specifying the appropriate disk or partition to use for this virtual machine.

**Caution:** Corruption is possible if you allow the virtual machine to modify a partition that is simultaneously mounted under Linux. Since the virtual machine and guest operating system access an existing partition while the host continues to run Linux, it is critical that the virtual machine not be allowed to modify any partition mounted under Linux or in use by another virtual machine.

To safeguard against this problem, be sure the partition you use in the virtual machine is not mounted under the Linux host.

9. Complete the remaining steps in the wizard.
10. If you have multiple IDE drives configured on a system, the VMware BIOS normally attempts to boot them in this sequence:
  - a. Primary master
  - b. Primary slave
  - c. Secondary master
  - d. Secondary slave

If you have multiple SCSI drives configured on a system, the VMware BIOS normally attempts to boot them in the order of the SCSI device number.

If you have both SCSI and IDE drives configured, the VMware BIOS normally attempts to boot SCSI drives followed by IDE drives, in the order described above.

You can change the boot sequence using the Boot menu of the virtual machine's Phoenix BIOS. To enter the BIOS setup utility, power on the virtual machine and press F2 as the virtual machine begins to boot.

11. Power on the virtual machine. Click the **Power On** button. The virtual machine starts, runs the Phoenix BIOS, then boots from the master boot record (MBR).  
Choose the target operating system from the list of options offered by the boot manager.



- Remember that your virtual machine hardware environment, which the guest operating system is about to run in for the first time, probably differs significantly from the physical hardware of your machine.

For Windows guest operating systems, Plug and Play reconfigures Windows. Set up your virtual hardware profile with the devices found and configured by Plug and Play. See [Setting Up Hardware Profiles in Virtual Machines on page 225](#) for more information.

- Install VMware Tools in your guest operating system.

**Warning:** If you take snapshots while using your raw disk, before you reboot your guest operating system natively you must either:

- Revert to a snapshot and delete all other snapshots.
- Delete all snapshots.

This is necessary because any changes to sectors on the physical disk that have been modified on the disk invalidate all snapshots for the disk.

## Setting Up Hardware Profiles in Virtual Machines

Certain operating systems use hardware profiles to load the appropriate drivers for a given set of hardware devices. If you have a dual-boot system and want to use a virtual machine to boot a previously installed operating system from an existing partition, you must set up “physical” and “virtual” hardware profiles.

Only users who are familiar with VMware Workstation virtual machines and the Windows hardware profiles concept should attempt this.

If you haven't already done so, review [Configuring Dual- or Multiple-Boot Systems to Run with VMware Workstation on page 219](#) before proceeding.

Each virtual machine provides a platform that consists of the following set of virtual devices:

- Virtual DVD/CD-ROM
- Virtual IDE and SCSI hard disk drives
- Standard PCI graphics adapter
- Standard floppy disk drive
- Intel 82371 PCI Bus Master IDE controller (includes primary and secondary IDE controllers)
- BusLogic BT-958 compatible SCSI host adapter
- Standard 101/102-key keyboard
- PS/2-compatible mouse
- AMD PCnet-PCI II compatible Ethernet adapter
- Serial ports (COM1-COM4)
- Parallel ports (LPT1-LPT2)
- Two-port USB hub
- Sound card compatible with the Sound Blaster AudioPCI
- 82093AA IOAPIC

This set of virtual devices is different from the set of physical hardware devices on the host computer and is independent of the underlying hardware with a few exceptions (the processor itself is such an exception). This feature provides a stable platform and allows operating system images installed within a virtual machine to be migrated to other physical machines, regardless of the configuration of the physical machine.

If an operating system is installed directly into a VMware Workstation virtual machine, the operating system properly detects all the virtual devices by scanning the hardware. However, if an operating system is already installed on the physical computer (for example, in a dual-boot configuration), the operating system already is configured to use the physical hardware devices. In order to boot such a preinstalled operating system in a virtual machine, you need to create separate hardware profiles in order to simplify the boot process.

Microsoft Windows operating systems, beginning with Windows 95 and Windows NT 4.0, allow you to create hardware profiles. Each hardware profile is associated with a set of known devices. If more than one hardware profile exists, the system prompts the user to choose between different hardware profiles at boot time.

Windows 95, Windows 98, Windows Me, Windows 2000, Windows XP and Windows Server 2003 use Plug and Play at boot time to confirm that the actual devices match the chosen hardware profile. Mismatches lead to the automatic detection of new devices. Although this operation succeeds, it can be fairly slow.

Windows NT does not have Plug and Play support and uses the hardware profiles to initialize its devices. Mismatches lead to errors reported by the device drivers and the devices are disabled.

In order to set up hardware profiles for your physical and virtual machines, follow these steps:

1. Before running VMware Workstation to boot an operating system previously installed on a disk partition, boot the operating system natively and create two hardware profiles, which you can call Physical Machine and Virtual Machine. To do this, open **Control Panel > System**, then click the **Hardware Profiles** tab — or click the **Hardware** tab, then click **Hardware Profiles**, depending on the operating system. Click the **Copy** button and name the copies appropriately.
2. **Windows NT only:** While still running the operating system natively, use the Device Manager to disable some devices from the Virtual Machine hardware profile. To do this, open **Control Panel > Devices**, then select the individual devices to disable. Devices to disable in the Virtual Machine hardware profile include audio, MIDI and joystick devices, Ethernet and other network devices and USB devices. Remember to disable them in the Virtual Machine hardware profile only.

Skip this step if you are running Windows 95, Windows 98, Windows Me, Windows 2000, Windows XP or Windows Server 2003. The initial Plug and Play phase detects device mismatches.

3. Reboot the computer into your intended host operating system — for example, into Linux if you are running VMware Workstation on a Linux host.
4. Use the New Virtual Machine Wizard to configure your virtual machine as described in [Configuring Dual- or Multiple-Boot Systems to Run with VMware Workstation on page 219](#).
5. Boot the virtual machine and use your existing boot manager to select the guest operating system. Choose Virtual Machine at the hardware profile menu prompt. You encounter device failure messages and delays during this initial boot.

6. **Windows Server 2003, Windows XP and Windows 2000 guests:** After you log on to Windows Server 2003, Windows XP or Windows 2000 (now running as a guest operating system) you should see a Found New Hardware dialog box for the video controller as Plug and Play runs and discovers the virtual hardware. Do not install drivers at this time. Click **Cancel** to close the Found New Hardware dialog box.

Do not reboot the virtual machine. Click **No** in the System Settings Change/Reboot dialog box.

Windows Server 2003, Windows XP or Windows 2000 automatically detects and loads the driver for the AMD PCnet PCI Ethernet card. At this point, you should install VMware Tools inside the virtual machine. Allow the virtual machine to reboot after VMware Tools has been installed. Once Windows Server 2003, Windows XP or Windows 2000 reboots inside the virtual machine, select a new SVGA resolution from the **Settings** tab of the **Display Properties** dialog box to increase the size of the virtual machine's display window.

**Windows 95 and Windows 98 guests:** You should see New Hardware Detected dialog boxes as Plug and Play runs and discovers the virtual hardware. Windows prompts you for locations to search for device drivers. Most of the device drivers are available in the existing operating system installation, but you may need the installation CD-ROM for some networking device drivers. Windows also asks you to reboot your system several times as it installs the device drivers.

In some instances, Windows may not recognize the CD-ROM drive when it prompts you to insert the CD-ROM to look for device drivers during the initial hardware detection. In such cases, you can cancel the installation of the particular device or try pointing to `C:\windows\system\` to search for device drivers on the hard disk. Any failed device installations may be performed at a later time after the CD-ROM drive is recognized.

After Windows has installed the virtual hardware and its drivers, you can remove the failed devices corresponding to the physical hardware using the Device Manager (**Control Panel > System > Device Manager**).

Select the device, then click the **Remove** button. If a device appears in multiple hardware profiles, you can select the hardware profile or profiles from which to remove the device.

If you want to enable the virtual machine's sound adapter to work inside the Windows 9x guest operating system, finish the remaining steps in this section, then refer to [Configuring Sound on page 369](#).

**Windows NT guests only:** After the operating system has finished booting in the virtual machine, view the event log to see which physical devices have failed to start properly. You can disable them from the Virtual Hardware profile using the Device Manager (**Control Panel > Devices**).

If you want to enable the virtual machine's sound adapter to work inside the Windows NT guest operating system, finish the remaining steps in this section, then refer to [Configuring Sound on page 369](#).

7. Confirm that your virtual devices — specifically, the network adapter — are working properly.

**Windows 95 and Windows 98 guests:** If any virtual device is missing, you can detect it by running **Control Panel > Add New Hardware**.

8. Install VMware Tools. VMware Tools appears and runs in both hardware configurations but affects only the virtual machine.

**Note:** The next time you reboot Windows natively using the Physical Machine hardware profile, some virtual devices may appear in the device list. You can disable or remove these virtual devices from the Physical Machine hardware profile in the same way that you removed physical devices from the virtual machine hardware profile in step 6, above.

## Running a Windows 2000, Windows XP or Windows Server 2003 Virtual Machine from an Existing Multiple-Boot Installation

If you have installed Windows 2000, Windows XP or Windows Server 2003 on a computer, then try to run that same installation of the operating system as a VMware Workstation virtual machine running from a raw disk, the virtual machine may fail with an error message reporting an inaccessible boot device.

The problem occurs because the physical computer and the virtual machine require different IDE drivers. The Windows plug and play feature, which handles drivers for many hardware devices, does not install new IDE drivers.

If you encounter this problem, VMware recommends that you install your Windows 2000, Windows XP or Windows Server 2003 guest operating system in a virtual disk, rather than running it from a raw disk.

If you encounter this problem but it is important for you to run the virtual machine from the existing raw disk configuration, you can set up separate hardware profiles (described in [Setting Up Hardware Profiles in Virtual Machines on page 225](#)) and manually update the IDE driver in the profile for the virtual machine. For a detailed description of the workaround, see the VMware knowledge base ([www.vmware.com/info?id=41](http://www.vmware.com/info?id=41)).

## Setting Up the SVGA Video Driver for a Windows 95 Guest Operating System Booted from a Raw Disk

This section explains how to configure the video driver in a Windows 95 raw disk installation using VMware Workstation. The steps below assume you are using Windows 95 as one of the operating systems in a dual-boot or multiple-boot configuration. Following these steps, you create separate hardware profiles for your virtual machine and your physical machine. For more details on hardware profiles, see [Setting Up Hardware Profiles in Virtual Machines on page 225](#).

1. Boot Windows 95 natively (not in a virtual machine).
2. Right-click the **My Computer** icon on the desktop, then select **Properties**.
3. Click the **Hardware Profiles** tab.
4. Highlight the **Original Configuration** profile, then click **Copy**.
5. Name the profile Virtual Machine, then click **OK**.

You may also want to rename the Original Configuration profile to Physical Machine.

6. Click **OK** to close the System Properties dialog box.
7. Shut down Windows 95 and reboot the system.
8. Boot into your host operating system (Linux, Windows NT, Windows 2000, Windows XP or Windows Server 2003).
9. Start the Windows 95 virtual machine.
10. Select **Virtual Machine** from the list of profiles when prompted.
11. If you are prompted to select the CPU Bridge, accept the default, then click **OK**.
12. Restart Windows 95 when prompted.
13. Again, select **Virtual Machine** from the list of profiles when prompted.
14. When the video card is detected, you are prompted to select which driver you want to install for your new hardware. Click the **Select from a list of alternate drivers** radio button, then click **OK**.
15. Select **Display Adapters** from the Select Hardware Type dialog box.
16. Select **Standard Display Adapter (VGA)** from the device list, then click **OK**.
17. Restart Windows 95 when prompted.
18. Install VMware Tools as outlined in [Installing a Guest Operating System and VMware Tools on page 117](#), then restart the virtual machine.
19. Start the Device Manager and expand the **Display adapters** tree.
20. Highlight **VMware SVGA**. Click **Properties**.
21. Uncheck **Physical Machine**, then click **OK**. Click **Close**.
22. Shut down Windows 95 and power off the virtual machine.
23. Shut down your host operating system (Linux, Windows NT, Windows 2000, Windows XP or Windows Server 2003) and reboot into Windows 95.
24. Select the **Physical Machine** profile when prompted.
25. Repeat steps 19 through 21 and uncheck **Virtual Machine**, leaving **Physical Machine** checked.

## Setting Up the SVGA Video Driver for Use with a Windows 98 Guest Operating System Booted from a Raw Disk

This section explains how to configure the video driver in a Windows 98 raw disk installation using VMware Workstation. The steps below assume you are using Windows 98 as one of the operating systems in a dual-boot or multiple-boot configuration. Following these steps, you create separate hardware profiles for your virtual machine and your physical machine. For more details on hardware profiles, see [Setting Up Hardware Profiles in Virtual Machines on page 225](#).

1. Boot Windows 98 natively (not in a virtual machine).
2. Right-click the **My Computer** icon on the desktop, then select **Properties**.
3. Click the **Hardware Profiles** tab.
4. Highlight the **Original Configuration** profile, then click **Copy**.
5. Name the profile Virtual Machine, then click **OK**.

You may also want to rename the Original Configuration profile to Physical Machine.

6. Click **OK** to close the System Properties dialog box.
7. Shut down Windows 98 and reboot the system.
8. Boot into your host operating system (Linux, Windows NT, Windows 2000, Windows XP or Windows Server 2003).
9. Select **Virtual Machine** from the list of profiles when prompted.
10. Windows 98 auto-detects the virtual machine's devices and installs the device drivers.
11. When Windows detects the video card driver, select **Search for the best driver**.
12. When prompted to reboot, click **No**. The AMD PCNET driver is installed, followed by the IDE controller drivers.
13. When prompted to reboot, click **Yes**.
14. Select the **Virtual Machine** hardware profile.
15. After Windows 98 has completed booting, start the Add New Hardware wizard from the Control Panel.
16. Click **Next**, then **Next** again.
17. Select **No, the device isn't in the list**.
18. Click **Yes**, then click **Next**.



19. After all devices have been detected, click the **Details** button to list the detected non-Plug and Play devices.
20. Click **Finish**, then reboot the virtual machine when prompted.
21. Select the **VMware Workstation** configuration profile. Notice that an unknown monitor is detected and installed.
22. Install VMware Tools as outlined in [Installing a Guest Operating System and VMware Tools on page 117](#).
23. Open the Device Manager. It should show that you have
  - Standard PCI Graphics Adapter
  - VMware SVGA Display Adapter
24. Shut down the Windows 98 virtual machine and your host operating system.
25. Boot natively into Windows 98, then start the Device Manager.
26. Select the **VMware SVGA** device if listed, then click **Remove**.
27. Select the **Remove from Specific Configuration** radio button, then select **Physical Machine** from the configuration list.
28. Click **OK**, then reboot Windows 98 when prompted.
29. Boot into Windows 98 natively and verify the display settings. You should be able to use the display driver that you installed natively before starting this procedure.

## **Do Not Use Windows 2000, Windows XP and Windows Server 2003 Dynamic Disks as Raw Disks**

Windows 2000, Windows XP and Windows Server 2003 support a disk type called a dynamic disk. Dynamic disks use a proprietary Microsoft format for recording partition information. This format is not publicly documented and thus is not supported for use in raw disk configurations under VMware Workstation.

Windows 2000, Windows XP and Windows Server 2003 also support the older type of partition table. Disks that use this type of partition table are called basic disks.

You can use the disk management tool to check the type of disk used on your Windows 2000, Windows XP or Windows Server 2003 host and, if it is a dynamic disk, change it to basic.

**Caution:** If you change a dynamic disk to a basic disk, you lose all data on the disk.

Use this procedure to convert a dynamic disk to a basic disk.

1. Open the disk management tool.  
**Start > Settings > Control Panel > Administrative Tools > Computer Management > Disk Management**
2. Delete all logical volumes on the disk. This destroys all data on the disk.
3. Right-click the disk icon and select **Revert to Basic Disk**.
4. Create the partitions you want on the disk.

## Configuring Dual- or Multiple-Boot SCSI Systems to Run with VMware Workstation on a Linux Host

It may be possible to configure VMware Workstation so that you can use an operating system already installed and configured on a SCSI disk as a guest operating system inside a VMware Workstation virtual machine.

Using an existing SCSI disk — or SCSI raw disk — inside a virtual machine is supported only if the host has an LSI Logic or BusLogic SCSI adapter. LSI Logic is the preferred choice because it is easier to find drivers for LSI Logic adapters. It may be possible to configure a host with a different SCSI adapter so the same operating system can be booted both natively and inside a virtual machine, but this approach is not supported by VMware. For details on some of the key issues involved, see [Known Issues and Background Information on Using SCSI Raw Disks on page 238](#).

### Before You Create the Virtual Machine Configuration

You must create a separate configuration for each guest operating system. Allow read and write access to the partitions used by that operating system only.

1. Before starting, if you are running a Windows guest operating system you should read [Setting Up Hardware Profiles in Virtual Machines on page 225](#). You should boot the guest operating system natively on the computer and create a hardware profile for the virtual machine before proceeding.
2. Check to see what SCSI ID is set for the drive you plan to use in the virtual machine.
3. Make certain that in addition to any SCSI drivers you have configured for the host, you have also installed the driver for the LSI Logic or BusLogic virtual adapter you plan to use in the virtual machine.

Drivers for LSI Logic controllers are available from the LSI Logic Web site — [www.lsilogic.com](http://www.lsilogic.com). In the download area of the site, find a driver for any of the adapters in the LSI53C10xx Ultra320 SCSI I/O controller series — for example, the LSI53C1000.

**Note:** Drivers for a Mylex (BusLogic) compatible host bus adapter are not obvious on the LSI Logic Web site. Search the support area for the numeric string in the model number. For example, search for “958” for BT/KT-958 drivers.

The LSI Logic or BusLogic driver needs to be installed in the profile for the guest operating system.

**Note:** To use the virtual BusLogic SCSI adapter in a Windows XP or Windows Server 2003 virtual machine, you need a special SCSI driver available from the download section of the VMware Web site [www.vmware.com/download](http://www.vmware.com/download).

4. Check operating system partition mounts. Be sure the existing raw disk partitions that you plan to configure the virtual machine to use are not mounted by the Linux host.

**Caution:** A raw disk partition should not be used (mounted) simultaneously by the host and the guest operating system. Because each operating system is unaware of the other, data corruption may occur if both operating systems read or write to the same partition. It is critical that the virtual machine not be allowed to modify any partition mounted under the Linux host or in use by another virtual machine. To safeguard against this problem, be sure the partition you use for the virtual machine is not mounted under the Linux host.

5. Set the device group membership or device ownership. The master raw disk devices must be readable and writable by the user who runs VMware Workstation. On most distributions, the raw devices (such as `/dev/hda` and `/dev/hdb`) belong to group-id `disk`. If this is the case, you can add VMware Workstation users to the `disk` group. Another option is to change the owner of the device. Please think carefully about security issues when you explore different options here.

It is typically a good idea to grant VMware Workstation users access to all `/dev/hd[abcd]` raw devices that contain operating systems or boot managers and then rely on VMware Workstation's raw disk configuration files to guard access. This provides boot managers access to configuration and other files they may need to boot the operating systems. For example, LILO needs to read `/boot` on a Linux partition to boot a non-Linux operating system that may be on another drive.

6. If you plan to run a second Linux installation from an existing partition as a guest operating system, and your physical machine's `/etc/lilo.conf` has a memory register statement such as `Append= "mem..."`, you may want to adjust the append memory parameter or create a new entry in LILO for running Linux in a virtual machine.

Many newer Linux distributions recognize all physical memory in the physical machine, whereas many older Linux distributions see only the first 64MB of memory by default. Machines with more than 64MB of memory that run the older distributions may have the `Append= "mem=..."` parameter added under the `Image=...` section of `lilo.conf` to tell Linux to look for more memory than seen by default.

If the amount of memory configured in `lilo.conf` exceeds the amount of memory assigned to the virtual machine, the guest operating system is likely to panic when the virtual machine tries to boot the second Linux installation.

You can create another entry in `lilo.conf` for running Linux in a virtual machine by specifying a different amount of memory than what should normally be recognized when Linux boots directly on the physical machine.

### Setting Up the Virtual Machine Configuration

1. Start VMware Workstation.
2. Start the New Virtual Machine Wizard (**File > New > Virtual Machine**) and select **Custom**.
3. When you reach the Select I/O Adapter Types step, select the SCSI adapter type that matches the driver you installed in the virtual machine profile.
4. When you reach the Select a Disk step, select **Use a physical disk**.
5. In the **Device** list, select the physical drive.

Under **Usage**, select whether to use the entire disk or individual partitions.

If you selected **Use entire disk**, click **Next** then go to step 6.

If you selected **Use individual partitions**, the Select Physical Disk Partitions panel appears.

Select the partitions you want the virtual machine to use, then click **Next**.

6. In the entry field, enter a name of your choice for the physical disk.

**Caution:** If you browse to place the disk file in another directory, do not select an existing virtual disk file.

To specify a device ID for the physical disk, click **Advanced**. In the **Virtual device node** list, select the SCSI ID that corresponds to the one used by your SCSI drive. For example, if your SCSI drive has SCSI ID 2, select **SCSI 0:2**. If you do not know the SCSI ID set on your physical SCSI drive, try using **SCSI 0:0**.

On the advanced settings screen, you can also specify a disk mode. This is useful in certain special-purpose configurations in which you want to exclude disks from snapshots. For more information on the snapshot feature, see [Using Snapshots on page 251](#).

Normal disks are included in snapshots. In most cases, this is the setting you want.

Independent disks are not included in snapshots. You have the following options for an independent disk:

- **Persistent** — changes are immediately and permanently written to the disk.
- **Nonpersistent** — changes to the disk are discarded when you power off or revert to a snapshot.

When you have set the filename and location you want to use and have made any selections you want to make on the advanced settings screen, click **Finish**.

7. Begin using your virtual machine.

## Known Issues and Background Information on Using SCSI Raw Disks

### Size

VMware Workstation supports raw disk sizes up to 2.0TB. Reported size is not accurate with larger raw disks.

### Geometry

In some cases, it is not possible to boot a raw SCSI drive inside a virtual machine because the SCSI adapter in the physical computer and the BusLogic adapter in the virtual machine describe the drive in different ways. The virtual machine might hang during the boot, VMware Workstation might crash or VMware Workstation might fail with an ASSERT or other error message.

This problem is most likely to affect smaller drives — less than 2GB.

In order to share the same BIOS interface used by IDE disks (which is required in order to boot), all SCSI disks need to have a geometry, which is a fabricated value for the number of cylinders, sectors and heads on the disk.

In fact, a SCSI disk appears to a computer as a single flat entity from sector 1 up to the highest sector on the disk. As a result, every SCSI vendor has its own approach to taking the capacity of a SCSI disk and generating a geometry to use for booting.

The conversion from a given geometry to an absolute sector number depends on the geometry. If you have a disk with a boot sector written by a program running on the host and you try to boot that disk inside a virtual machine, the boot program can fail if the host geometry does not match the geometry used by the BusLogic virtual SCSI adapter. The symptoms are that you see the first part of the boot loader — possibly an `LI` from LILO, for example — but then the boot either stops or crashes.

BusLogic uses the following rules for generating disk geometries:

Disk size	Heads	Sectors
<= 1GB	64	32
> 1GB and <= 2GB	128	32
> 2GB	255	63

In each case the number of cylinders is calculated by taking the total capacity of the disk and dividing by (heads\*sectors). Fortunately, for sufficiently big disks, practically all vendors use 255 heads and 63 sectors.

### Drivers

In contrast to IDE adapters, SCSI adapters are not interchangeable and cannot all use the same drivers. That is, if you have an Adaptec SCSI host adapter in your machine and you remove it and replace it with a BusLogic SCSI host adapter, your operating system will most likely fail to boot unless you install a BusLogic driver.

Dual booting from a disk that is also used as a virtual disk is no different. To your operating system, it appears that the SCSI card in the machine suddenly changed from whatever you own to an LSI Logic or BusLogic card, and your operating system needs to have a corresponding driver installed. If that driver is not installed, you get a panic, a blue screen or some similar fatal error as soon as the boot process tries to switch from the BIOS bootstrap to the disk driver installed in the operating system.

### Operating System Configuration

Many operating systems have configuration information that is different for SCSI and IDE drives. For example, Linux uses `/dev/hd [x]` as the device name for IDE disks and `/dev/sd [x]` for SCSI disks. References to these names appear in `/etc/fstab` and other configuration files.

This is one reason that booting a raw IDE disk as a SCSI disk or vice versa does not work well (if at all).

However, even when you are dealing only with SCSI devices, it is possible for an operating system to encode information in a way that causes problems when you are dual booting. For example, Solaris names its SCSI disks `/dev/c [x] t [y] d [z] s0`, where the `y` represents the SCSI ID. So if you had a raw disk configured as SCSI ID 3 on the host and as SCSI ID 0 in your VMware Workstation configuration file, it would move if you were running Solaris, and most likely Solaris would not boot.

The precise dependencies in various operating systems can be complex. That is why it is safest to configure SCSI raw disks in a virtual machine using the same SCSI ID as they use on the host.



## Installing an Operating System onto a Physical Partition from a Virtual Machine

In some situations, you may want to install a guest operating system directly on a physical disk or partition even if you do not need to boot that disk on the host, outside of the virtual machine.

It is possible to use either an unused partition or a completely unused disk on the host as a disk in the virtual machine. However, it is important to be aware that an operating system installed in this setting probably cannot boot outside of the virtual machine, even though the data is available to the host.

If you have a dual-boot system and want to configure a virtual machine to boot from an existing partition, see [Configuring a Dual-Boot Computer for Use with a Virtual Machine on page 215](#). The instructions in this section do not apply to a disk with a previously installed operating system.

**Caution:** Physical disks are an advanced feature and should be configured only by expert users.

VMware Workstation uses description files to control access to each physical disk on the system. These description files contain access privilege information that controls a virtual machine's access to certain partitions on the disks. This mechanism prevents users from accidentally running the host operating system again as a guest or running a guest operating system that the virtual machine is not configured to use. The description file also prevents accidental writes to physical disk partitions from badly behaved operating systems or applications.

Use the New Virtual Machine Wizard to configure VMware Workstation to use existing physical disk partitions. The wizard guides you through creating a new virtual machine including configuring the physical disk description files. Rerun the wizard to create a separate configuration for each guest operating system installed on a physical partition.

- [Configuring a Windows Host on page 242](#)
- [Configuring a Linux Host on page 244](#)

## Configuring a Windows Host

### Windows 2000, Windows XP and Windows Server 2003 Dynamic Disks

If your host is running Windows 2000, Windows XP or Windows Server 2003 and is using dynamic disks, see [Do Not Use Windows 2000, Windows XP and Windows Server 2003 Dynamic Disks as Raw Disks on page 234](#).

### Configuring the Virtual Machine to Use a Physical Disk

Use the following steps to run a guest operating system from a physical disk.

**Note:** If you use a Windows host's IDE disk in a physical disk configuration, it cannot be configured as the slave on the secondary IDE channel if the master on that channel is a CD-ROM drive.

1. Identify the raw partition on which you plan to install the guest operating system.

Check the guest operating system documentation regarding the type of partition on which the operating system can be installed. For example, operating systems like DOS, Windows 95 and Windows 98 must be installed on the first primary partition while others, like Linux, can be installed on a primary or extended partition on any part of the drive.

Identify an appropriate physical partition or disk for the guest operating system to use. Be sure that the physical partition is not mounted by the Windows host and not in use by others. Also, be sure the physical partition or disk does not have data you will need in the future; if it does, back up that data now.

2. Start the New Virtual Machine Wizard (**File > New > Virtual Machine**) and select **Custom**.

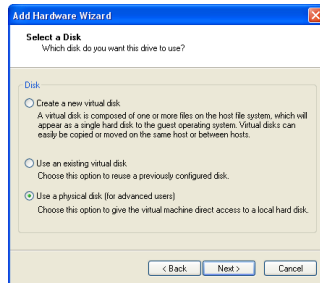

- When you reach the Select a Disk step, select **Use a physical disk**.

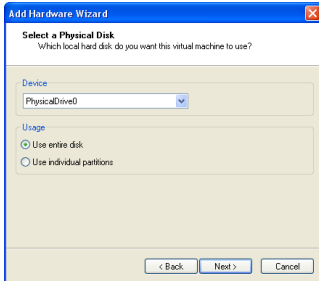

- Choose the physical hard disk to use from the drop-down list. Select whether you want to use the entire disk or use only individual partitions on the disk. Click **Next**.

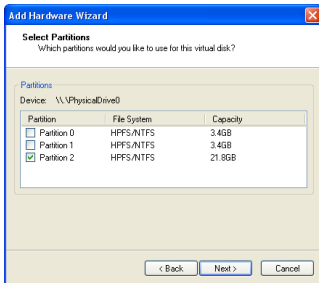

- If you selected **Use individual partitions** in the previous step, select which partitions you want to use in the virtual machine. If you selected **Use entire disk**, this step does not appear.  
Click **Next**.
- The partition on which you are installing the guest operating system should be unmapped in the host.

**Caution:** Corruption is possible if you allow the virtual machine to modify a partition that is simultaneously mounted under Windows. Since the virtual machine and guest operating system access a physical disk partition while the host continues to run Windows, it is critical that you not allow the virtual machine to modify any partition mounted by the host or in use by another virtual machine. To safeguard against this problem, be sure the physical disk partition you use for the virtual machine is not in use by the host.

**Windows Server 2003, Windows XP or Windows 2000 host:** Use Disk Management (**Start > Settings > Control Panel > Administrative Tools > Computer Management > Storage > Disk Management**). Select the partition you want to unmap, then choose **Action > All Tasks > Change Drive Letter and Path**. Click the **Remove** button.

7. Use the virtual machine settings editor (**VM > Settings**) if you want to change any configuration options from the wizard defaults — for example, to change the amount of memory allocated to the guest operating system.
8. At this point you are ready to begin installing the guest operating system onto the physical disk you configured for the virtual machine. For more details, read the installation notes for various guest operating systems in the *VMware Guest Operating System Installation Guide*, available from the VMware Web site or from the Help menu.

## Configuring a Linux Host

1. Identify the physical partition on which the guest operating system will be installed.

Check the guest operating system documentation regarding the type of partition on which the operating system can be installed. For example, operating systems like DOS, Windows 95 and Windows 98 must be installed on the first primary partition while others, like Linux, can be installed on a primary or extended partition on any part of the drive.

Identify an appropriate physical partition or disk for the guest operating system to use. Check that the physical partition is not mounted by the Linux host and not in use by others. Also, be sure the physical partition or disk does not have data you will need in the future; if it does, back up that data now.

2. Check the operating system partition mounts. Be sure the existing disk partitions that you plan to use in the virtual machine are not mounted by Linux.
3. Set the device group membership or device ownership.

The master physical disk device or devices need to be readable and writable by the user who runs VMware Workstation. On most distributions, the physical devices, such as `/dev/hda` (IDE physical disk) and `/dev/sdb` (SCSI physical disk) belong to group-id `disk`. If this is the case, you can add VMware Workstation users to the `disk` group. Another option is to change the owner of the device. Please think carefully about security issues when you explore different options here.

It is a good idea to grant VMware Workstation users access to all `/dev/hd [abcd]` physical devices that contain operating systems or boot managers, then rely on VMware Workstation's physical disk configuration files to guard access. This provides boot managers access to configuration and other files they may need to boot the operating systems. For example, LILO needs to read `/boot` on a Linux partition to boot a non-Linux operating system that may be on another drive.

4. Start the New Virtual Machine Wizard (**File > New > Virtual Machine**) and select **Custom**.
5. When you reach the Select a Disk step, select **Use a physical disk**.
6. If the physical disk you plan to use has multiple partitions on it already, be aware that certain operating systems (DOS, Windows 95, Windows 98) must be installed on the first primary partition.

**Caution:** Corruption is possible if you allow the virtual machine to modify a partition that is simultaneously mounted under the Linux host operating system. Since the virtual machine and guest operating system access an existing partition while the host continues to run Linux, it is critical that the virtual machine not be allowed to modify any partition mounted by the host or in use by another virtual machine.

To safeguard against this problem, be sure the partition you use for the virtual machine is not mounted under the Linux host.

7. At this point you are ready to begin installing the guest operating system on the physical disk you configured for the virtual machine. For more details, read the installation notes for various guest operating systems in the *VMware Guest Operating System Installation Guide*, available from the VMware Web site or from the Help menu.

## Legacy Virtual Disks

VMware Workstation 5 introduces features that were not available in previously released VMware products. See [What's New in Version 5 on page 19](#) for a list of these features.

Workstation 5 achieves its new functionality by using a new virtual machine format, a format that is not compatible with the legacy disk format used by these VMware applications:

- Workstation 4.x
- GSX Server 3.x
- ESX Server 2.x
- VMware ACE 1.x

VMware Workstation 5 does work with legacy virtual disks, allowing easy integration into environments using these other VMware products.

The following sections discuss your options for using Workstation 5 in a mixed environment with legacy virtual machines created in Workstation 4.x, GSX Server 3.x, ESX Server 2.x or VMware ACE 1.x.

- [Upgrading a Legacy Virtual Machine for New Features of Workstation 5 on page 247](#)
- [Using a Legacy Virtual Machine without Upgrading on page 247](#)
- [Creating a Legacy Virtual Machine with Workstation 5 on page 247](#)

## Upgrading a Legacy Virtual Machine for New Features of Workstation 5

In order to use features of Workstation 5 with legacy virtual machines, you must upgrade the virtual machine hardware, as described in [Use a Legacy Virtual Machine with Upgrade on page 58](#).

**Note:** After the upgrade, the virtual machine is fully compatible with virtual machines created in Workstation 5. You cannot use the upgraded virtual machine in Workstation 4.x, GSX Server 3.x, ESX Server 2.x or VMware ACE 1.x.

## Using a Legacy Virtual Machine without Upgrading

Workstation 5 can power on an unmodified legacy virtual machine, allowing you to share a virtual machine with users of Workstation 4.x, GSX Server 3.x, ESX Server 2.x and ACE 1.x. However, Workstation 5 features are not available in this legacy virtual machine.

**Note:** When you are running a legacy virtual machine, Workstation 5 indicates that VMware Tools is out of date. Do not upgrade your VMware Tools if you want to continue using the virtual machine on Workstation 4.x, GSX Server 3.x, ESX Server 2.x and VMware ACE 1.x.

## Creating a Legacy Virtual Machine with Workstation 5

Workstation 5 can create a new virtual machine to use in Workstation 4.x, GSX Server 3.x, ESX Server 2.x and VMware ACE 1.x. However, the new features of Workstation 5 are not available in this legacy virtual machine.

See [Steps to a New Virtual Machine on page 102](#) for a discussion of creating a new virtual machine using Workstation 5.





# Preserving the State of a Virtual Machine

---

VMware Workstation 5 provides two ways to preserve the state of a virtual machine: you can Suspend the virtual machine, or take a Snapshot of it. This chapter describes the Suspend and Snapshot features and helps you understand when to use them.

- [Using Suspend and Resume on page 250](#)
- [Using Snapshots on page 251](#)
  - [Examples of Using Snapshots on page 254](#)
  - [What Is Captured by a Snapshot? on page 255](#)
  - [Taking a Snapshot on page 256](#)
  - [The Snapshot Manager on page 258](#)
  - [Restoring a Snapshot: Revert or Go To? on page 263](#)
  - [Deleting a Snapshot on page 264](#)
  - [Making a Clone from a Snapshot on page 264](#)
  - [Virtual Machine Settings for Snapshots on page 265](#)

## Using Suspend and Resume

The suspend and resume feature is useful when you want to save the current state of your virtual machine, and continue work later from the same state.

Once you resume and do additional work in the virtual machine, there is no way to return to the state the virtual machine was in at the time you suspended. To preserve the state of the virtual machine so you can return to the same state repeatedly, take a snapshot. For details, see [Using Snapshots on page 251](#).

The speed of the suspend and resume operations depends on how much data has changed while the virtual machine has been running. In general, the first suspend operation takes a bit longer than later suspend operations do.

When you suspend a virtual machine, a file with a `.vms` extension is created. This file contains the entire state of the virtual machine. When you resume the virtual machine, its state is restored from the `.vms` file.

To suspend a virtual machine:

1. If your virtual machine is running in full screen mode, return to window mode by pressing the Ctrl-Alt key combination.
2. Click **Suspend** on the VMware Workstation toolbar.
3. When VMware Workstation has completed the suspend operation, it is safe to exit VMware Workstation.

**File > Exit** (Windows)

or

**File > Quit** (Linux)

To resume a virtual machine that you have suspended:

1. Start VMware Workstation and choose a virtual machine you have suspended.
2. Click **Resume** on the VMware Workstation toolbar.

Note that any applications you were running at the time you suspended the virtual machine are running and the content is the same as it was when you suspended the virtual machine.

## Using Snapshots

VMware Workstation snapshots allow you to preserve the state of the virtual machine so you can return to the same state repeatedly. Version 5 introduces multiple snapshots and the snapshot manager.

This section discusses snapshots in the following topics:

- [Understanding Snapshots on page 252](#)
- [Examples of Using Snapshots on page 254](#)
- [What Is Captured by a Snapshot? on page 255](#)
- [Taking a Snapshot on page 256](#)
- [The Snapshot Manager on page 258](#)
- [Restoring a Snapshot: Revert or Go To? on page 263](#)
- [Virtual Machine Settings for Snapshots on page 265](#)
- [Deleting a Snapshot on page 264](#)
- [Making a Clone from a Snapshot on page 264](#)
- [Snapshots and Legacy Virtual Machines on page 266](#)
- [Snapshots and Other Activity in the Virtual Machine on page 255](#)

## Understanding Snapshots

Taking a snapshot saves the current state of the virtual machine, so you can return to it at any time. Snapshots are useful when you need to revert a virtual machine repeatedly to the same state, but you don't want to create multiple virtual machines.

If you simply want to save the current state of your virtual machine temporarily, so you can continue work later from the same state, see [Using Suspend and Resume on page 250](#).

You can take multiple snapshots of a virtual machine, to save any state you might want to return to.

**Note:** To take snapshots of multiple virtual machines — for example, taking snapshots for all members of a team — requires that you take a separate a snapshot of each team member.

### Snapshots in a Linear Process

One common use of snapshots is in a development process, as a way to save each step in a linear process. That way, as you add new, untested code to a project, you can always revert to a prior known working state of the project when newly added code does not work as expected.

Another example of using snapshots in a linear process is a computerized training course. You can take snapshots of each lesson starting point, so you can instantly revert to the appropriate place for each student — skipping lengthy computer preparation time.



*Snapshots as restore points in a linear process*

VMware Workstation supports over 100 snapshots per linear process.

### Snapshots in a Process Tree

Another way to use snapshots is shown in the following figure. Here, instead of saving each step of a process in a single long sequence, you are saving a number of sequences, as branches from a single baseline. This strategy is often used in testing

software, for example. You can take a snapshot before installing different versions of a program to ensure each different installation begins from an identical baseline.

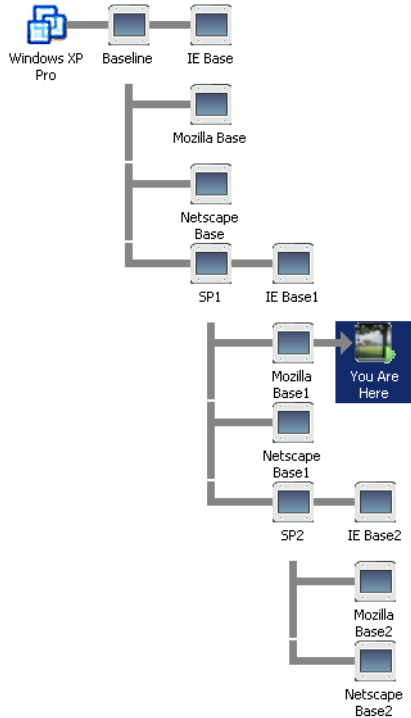

*Snapshots as restore points in a process tree*

VMware Workstation supports over 100 snapshots per branch in a process tree.

### Relationship Between Snapshots

The relationship between snapshots is like parent to child.

- In a linear process, each snapshot has one parent and one child, except for the last snapshot, which has no children.
- In a process tree, each snapshot has one parent, but one snapshot may have more than one child. Many snapshots have no children.

## Examples of Using Snapshots

### Using Snapshots as Protection from Risky Changes

If you plan to make risky changes in a virtual machine (for example, testing new software or examining a virus), take a snapshot before you begin. If you encounter a problem, you can restore the virtual machine to the state preserved in that snapshot.

If your risky actions cause no problems you can take another snapshot of the virtual machine in its new state. Snapshots can minimize lost work if something goes wrong. With multiple snapshots of saved positions, you can return at any time to any important position when you discover a problem.

### Starting a Virtual Machine Repeatedly in the Same State

You can configure the virtual machine to revert to a snapshot any time it is powered off. You might use this feature, for example, in setting up student virtual machines to power on for each new class at the beginning of the lesson, discarding previous student work. See [Reverting at Power Off on page 263](#) for the procedure.

### Automatically Recording Milestone Status

You can configure a virtual machine to take a snapshot any time it is powered off, preserving a virtual audit trail as work progresses. See [Virtual Machine Settings for Snapshots on page 265](#) for configuring automatic snapshots at power off.

### Disabling Snapshots for Better Performance

VMware Workstation operates more efficiently with snapshots disabled. If you do not need to use snapshot functionality, you should disable it for better performance. See [Virtual Machine Settings for Snapshots on page 265](#).

## What Is Captured by a Snapshot?

A snapshot captures the entire state of the virtual machine at the time you take the snapshot. This includes:

- Memory state — The contents of the virtual machine's memory
- Settings state — The virtual machine settings
- Disk state — The state of all the virtual machine's virtual disks

Snapshots operate on individual virtual machines. In a team of virtual machines, taking a snapshot preserves only the active virtual machine's state. See [The Active Virtual Machine on page 297](#).

When you revert to a snapshot, you return the virtual machine's memory, settings, and virtual disks, to the state they were in when you took the snapshot. If you want the virtual machine to be suspended, powered on, or powered off when you launch it, be sure it is in the desired state when you take the snapshot.

**Note:** The state of a physical disk or independent disk is not preserved when you take a snapshot.

### Snapshots and Other Activity in the Virtual Machine

When you take a snapshot, be aware of other activity going on in the virtual machine and the likely impact of reverting to that snapshot. In general, it is best to take a snapshot when no applications in the virtual machine are communicating with other computers. The potential for problems is greatest if the virtual machine is communicating with another computer, especially in a production environment.

Consider a case in which you take a snapshot while the virtual machine is downloading a file from a server on the network. After you take the snapshot, the virtual machine continues downloading the file, communicating its progress to the server. If you revert to the snapshot, communications between the virtual machine and the server are confused and the file transfer fails.

Or consider a case in which you take a snapshot while an application in the virtual machine is sending a transaction to a database on a separate machine. If you revert to that snapshot — especially if you revert after the transaction starts but before it has been committed — the database is likely to be confused.

See [Snapshot Actions as Background Activity on page 256](#).

## Excluding Disks from Snapshots

In certain configurations, you may want to have some disks revert to a snapshot while other disks retain all changes. You can exclude virtual disks from a snapshot by changing the disk mode.

For example, you may want a snapshot to preserve a disk with your operating system and applications, while always keeping the changes to a disk with your documents. For the procedure, see [Changing Disk Mode to Exclude Virtual Disks from Snapshots on page 257](#).

## Taking a Snapshot

Use the Snapshot menu on the Workstation toolbar to take a snapshot.

1. Choose **VM > Snapshot > Take Snapshot**

2. Type a name for your snapshot.

Every snapshot must have a unique name. If you type the name of an existing snapshot, a warning appears and you must enter a different name.

3. If you wish, you may type a description for your snapshot.

Descriptions are useful to identify differences between similarly-named snapshots. Descriptions appear in the snapshot manager.

4. Click **OK**.

## Snapshot Actions as Background Activity

Taking a snapshot is not instantaneous. When you take a snapshot, you can continue working while VMware Workstation preserves the snapshot in the background. To enable background snapshots in the Priority tab of the Preferences window. See [Snapshots on page 81](#). Enabling background snapshots for a host with slow hard disks may affect performance. If you experience significant performance problems when taking or restoring snapshots, turn off this option.

If you take another snapshot or revert to one before Workstation completes a pending snapshot operation, a progress dialog box appears. When this occurs, you must wait for the pending snapshot operation to finish before the next snapshot or resume operation begins.

**Note:** If you select a snapshot in the snapshot manager before that snapshot is complete, Workstation displays an error message: The screen shot of the snapshot does not yet exist. This message does not indicate a permanent problem. When the snapshot is complete, a screen shot for the snapshot becomes visible in the snapshot manager, and no warning appears when you select that snapshot.



### When Can I Take a Snapshot?

You can take a snapshot while a virtual machine is powered on, powered off, or suspended. If you are suspending a virtual machine, wait until the suspend operation has finished before taking a snapshot.

For legacy virtual machines and multiple disks in different modes, the following exceptions apply.

- Snapshots and legacy virtual machines — you must upgrade a legacy virtual machine to Workstation 5 before taking a snapshot. For information on upgrading the virtual machine, see [Upgrading VMware Workstation on page 51](#). For more information about using Workstation 5 with virtual machines and snapshots created under Workstation versions 3 and 4, see [Snapshots and Legacy Virtual Machines on page 266](#).
- Snapshots and multiple disks in different modes — You must power off the virtual machine before taking a snapshot if the virtual machine has multiple disks in different disk modes. For example, if you have a special purpose configuration that requires you to use an independent disk, you must power off the virtual machine before taking a snapshot.

### Changing Disk Mode to Exclude Virtual Disks from Snapshots

Before you attempt to change the disk mode, you must power off the virtual machine and delete any existing snapshots.

To exclude a disk from all snapshots.

1. Choose **VM > Settings**.
2. Select the drive you want to exclude.
3. Click **Advanced**.
4. Select **Independent** on the advanced settings panel. You have the following options for an independent disk:
  - **Persistent** — changes are immediately and permanently written to the disk. All changes to an independent disk in persistent mode remain, even when you revert to a snapshot.
  - **Nonpersistent** — current changes to the disk are discarded when you power off or revert to a snapshot.

## The Snapshot Manager

In the snapshot manager (**VM > Snapshot > Snapshot Manager**), you can review all snapshots for the active virtual machine and act on them directly.

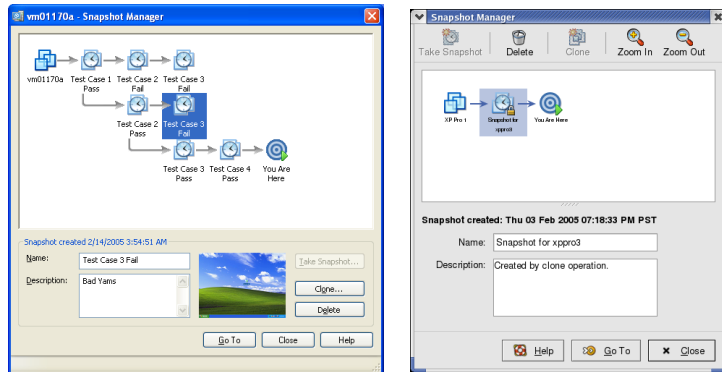

The snapshot manager: Windows host (left) and Linux host (right)

### Selecting a Snapshot

In the snapshot manager, select a snapshot by clicking it.

Double-clicking a snapshot is the same as selecting that snapshot and clicking **Go To Snapshot**.

### Going to a Snapshot

Use the **Go To** button to restore the virtual machine to the currently selected snapshot.

1. Choose **VM > Snapshot > Snapshot Manager**
2. Select the desired snapshot.
3. Click **Go to**.
4. Click **Yes** in the confirmation dialog box.

### Making a Clone from a Snapshot

In the snapshot manager, you can clone a virtual machine from any snapshot taken while the virtual machine is powered off. See [Making a Clone from a Snapshot on page 264](#).

### Deleting a Snapshot

Use the Delete button to permanently remove a snapshot from Workstation use.

1. Choose **VM > Snapshot > Snapshot Manager**.
2. Select the desired snapshot.
3. Click **Delete**.
4. Click **OK** in the confirmation dialog box.

### Editing Snapshot Name and Description

You can edit the name and description of a snapshot by typing in the appropriate field.

1. Choose **VM > Snapshot > Snapshot Manager**.
2. Select the desired snapshot.
3. Click within the **Name** or **Description** field to change that field.

Type your changes. When your cursor leaves the field, Workstation verifies your entry for length, duplicate names, and invalid characters.

**Note:** Pressing Esc accepts any edit in progress and closes the snapshot manager without confirmation.

## The Snapshot Manager Window

The following figures show the elements of the snapshot manager window. These elements are described in the following sections.

- [Snapshot Tree on page 261](#)
- [Details Region on page 261](#)
- [Command Buttons on page 261](#)
- [Navigation Region on page 262](#)
- [You Are Here Icon on page 262](#)

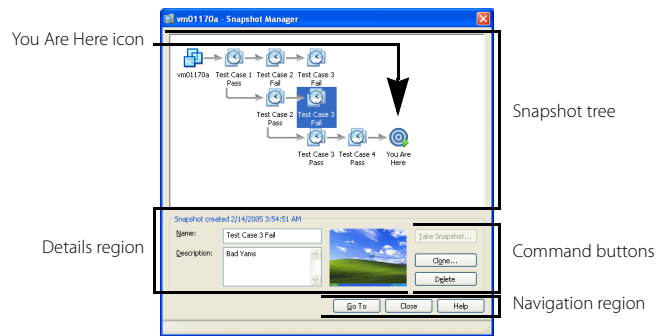

The snapshot manager: Windows host

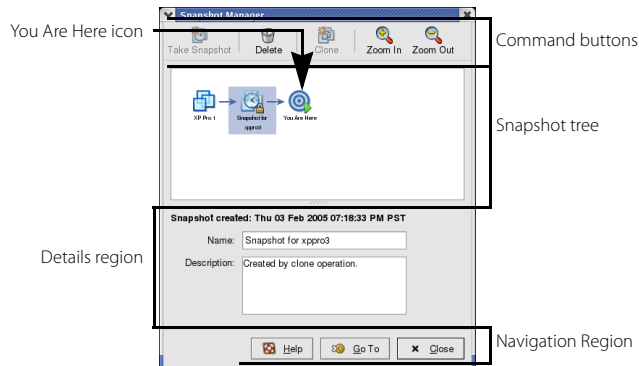

The snapshot manager: Linux host

**Snapshot Tree** — The snapshot tree shows all snapshots for the active virtual machine.

Linux hosts have a zoom feature to change the magnification of the tree.

- Click **Zoom In** to increase magnification for the snapshot tree display.
- Click **Zoom out** to decrease magnification for the snapshot tree display. If you have many snapshots, this feature allows you to view the whole snapshot tree.

You can act directly on snapshots in the snapshot tree.

Action	Description
Click a snapshot	Selects that snapshot. To act on the selected snapshots, click one of the command buttons: <b>Take Snapshot</b> , <b>Delete</b> , and <b>Clone</b> . See <a href="#">Command Buttons on page 261</a>
Double-click a snapshot	Reverts to that snapshot and restores the power state of the virtual machine at the time the snapshot was taken.
Right-click a snapshot	Displays a pop-up menu with commands available to that snapshot. <ul style="list-style-type: none"> <li>• <b>Go to Snapshot</b> — This command opens the selected snapshot as if you clicked the Go To Snapshot button.</li> <li>• <b>Clone This snapshot</b> — This command creates a stand-alone virtual machine called a clone. Refer to <a href="#">Cloning a Virtual Machine on page 267</a> for a description of clones.</li> <li>• <b>Delete Snapshot</b> — This command deletes the selected snapshot as if you clicked the Delete button. Snapshots that are children of the selected snapshot are not affected.</li> <li>• <b>Delete Snapshot and Children</b> — This command deletes the selected snapshot and all snapshots based from the selected snapshot.</li> </ul>
Move the cursor over a snapshot (without clicking)	Displays the complete name of that snapshot. This is useful when a long name is truncated in the snapshot tree display.

**Details Region** — This area displays information about the selected snapshot: name, description, and thumbnail screenshot. If you have not selected a snapshot, these fields are blank.

**Command Buttons** — The snapshot manager has three command buttons: Take Snapshot, Delete, and Clone.

**Note:** In the Linux snapshot manager, command buttons are displayed at the top. In the Windows snapshot manager, command buttons are on the right side.

Button	Description
Delete	Removes the selected snapshot. The state of the virtual machine represented by that snapshot is no longer available.
Clone	Creates a completely independent copy of the virtual machine from the selected snapshot. See <a href="#">Cloning a Virtual Machine on page 267</a> .
Take Snapshot	Creates a snapshot. See <a href="#">Taking a Snapshot on page 256</a> .

**Navigation Region** — This area contains buttons to navigate out of the dialog box.

- Go To — opens the selected snapshot and powers on the virtual machine, discarding the current state.
- Close — closes the snapshot manager.
- Help — opens the Workstation help system.

**You Are Here Icon** — The You Are Here icon always represents the current and active state of the virtual machine. The You Are Here icon is always selected and visible when you open the snapshot manager.

You cannot go to or select the You Are Here state. The You Are Here icon does not represent a snapshot, but rather the virtual machine state after the parent snapshot (see [The Parent Snapshot on page 263](#)). A snapshot is always a static record of a virtual machine state. The You Are Here state can be operational and changing.

## Restoring a Snapshot: Revert or Go To?

You can restore a snapshot in VMware Workstation by using the Revert and Go to commands. The following sections explain how these commands work.

### The Parent Snapshot

The parent snapshot of a virtual machine is the snapshot on which the current state (the You Are Here position) is based. After you take a snapshot, that stored state — the parent snapshot of the current state — is the parent snapshot of the virtual machine. If you revert or go to an earlier snapshot, the earlier snapshot becomes the parent snapshot of the virtual machine.

### Revert to Snapshot

Revert is essentially a shortcut for *Go to the parent snapshot of the virtual machine* — that is, the parent snapshot of the You Are Here position. Revert immediately activates the parent snapshot of the current state of the virtual machine. The current disk and memory states are discarded, and the virtual machine reverts to the disk and memory states of the parent snapshot.

To Revert to the parent snapshot, choose **VM > Snapshot > Revert to Snapshot**, or click the revert button on the toolbar.

### Go to Snapshot

This command activates the snapshot currently selected in the snapshot manager. Unlike Revert, the Go To command is not limited to the parent snapshot of the current state. You can choose any snapshot.

To go to a snapshot, choose **VM > Snapshot** and select the snapshot by name; or, in the snapshot manager, select a snapshot and click **Go To**.

### Reverting at Power Off

This setting causes the virtual machine to revert automatically to the parent snapshot any time it is powered off. The parent snapshot of a virtual machine is the snapshot on which the current state (the You Are Here position) is based (see [The Parent Snapshot on page 263](#)).

1. Choose **VM > Settings > Options > Snapshots**.
2. In the section **When powering off**, select **Revert to snapshot**.

## Deleting a Snapshot

You can delete a snapshot any time. Deleting snapshots does not affect other snapshots or the current state of the virtual machine.

To delete a snapshot

1. Choose **VM > Snapshot > Snapshot Manager**.
2. Select the snapshot to delete.
3. Click **Delete**.

A confirmation dialog box appears.

4. Click **OK**.

**Note:** You cannot delete the snapshot if the associated virtual machine is designated as a template for cloning. See [Linked Clones and Access to the Parent Virtual Machine on page 274](#) for a description of template settings for linked clones.

## Making a Clone from a Snapshot

VMware Workstation 5 snapshots are stored as changes from the parent state. To create a fully independent copy of a virtual machine from a snapshot, you can make a clone.

1. Choose **VM > Snapshot > Snapshot Manager**.
2. Select the snapshot to clone.

**Note:** The snapshot must be powered off before you can make a clone from it.

3. Click **Clone**.
4. Click **OK** in the confirmation dialog box.

See [Cloning a Virtual Machine on page 267](#).



## Virtual Machine Settings for Snapshots

In the virtual machine settings editor, you can disable snapshots and set the virtual machine to revert to a snapshot when you power off. The following sections describe these options.

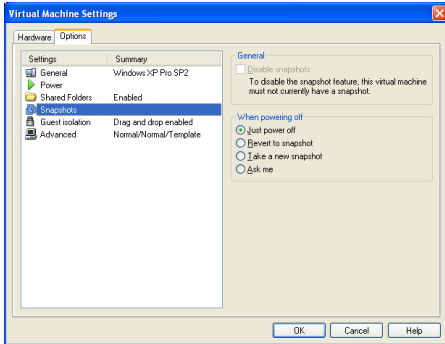

### Disabling Snapshots

VMware Workstation speed and response times are improved when snapshots are disabled. However, all changes made to a virtual machine are permanent and you cannot restore an earlier state.

To disable snapshots, go to **VM > Settings > Options > Snapshots**.

- If no snapshots exist for the selected virtual machine, you can disable snapshot functionality by selecting **Disable snapshots**.
- If one or more snapshots exist for the selected virtual machine, the Disable snapshots option is disabled. If you want to disable snapshot functionality, you must first delete all snapshots for the current virtual machine. Refer to [Deleting a Snapshot on page 264](#).

### Revert to a Snapshot When Powering Off

To set the virtual machine to revert to a snapshot when you power off, go to **VM > Settings > Options > Snapshots**. You have the following options when you power off a virtual machine that has a snapshot:

- **Just power off** — powers off the virtual machine without any change to its snapshots. This is the default setting.
- **Revert to snapshot** — reverts to the virtual machine's parent snapshot, that is, the parent snapshot of the current You Are Here position. With this setting, a virtual machine always starts in the same state. Reverting to the snapshot discards changes. For example, an instructor may need to discard student answers for a computer lesson when a virtual machine is powered off at the end of class.
- **Take a new snapshot** — takes a new snapshot of the virtual machine state after it is powered off. This is useful to preserve milestones automatically. The snapshot is displayed in the snapshot manager. The name of this snapshot is the date and time the virtual machine was powered off. The description is "Automatic snapshot created when powering off."
- **Ask me** — asks what you want to do with a snapshot each time you power off.

### Snapshots and Legacy Virtual Machines

When you power on a virtual machine created in Workstation 3 or 4, a dialog box gives you the choice to upgrade the virtual machine or to leave the virtual machine unchanged. For full Workstation 5 functionality, you must upgrade. If you do not upgrade, whenever you power on the legacy virtual machine, Workstation 5 offers you the choice to upgrade.

#### Upgrading Legacy Virtual Machines to Workstation 5

You can upgrade a legacy virtual machine from Workstation 3 or Workstation 4 to VMware Workstation 5. Any snapshot of the upgraded virtual machine is upgraded, and commands for multiple snapshots become available.

**Note:** An upgraded snapshot retains disk contents, but discards memory contents. When you power on that snapshot, it appears as if the virtual machine has crashed.

#### Using Legacy Virtual Machines without Upgrading

If you choose not to upgrade, you preserve the ability to use the virtual machine in older Workstation 3 or 4, but in Workstation 5 there is no snapshot functionality allowed. When you open a legacy virtual machine in Workstation 5, you see a warning message to this effect.

# Cloning a Virtual Machine

---

The following sections describe clones and configuring a clone:

- [Understanding Clones on page 268](#)
    - [Why Make a Clone? on page 268](#)
    - [Full and Linked Clones on page 269](#)
    - [Full Clones and Snapshots of the Parent on page 269](#)
  - [Creating Clones on page 270](#)
    - [The Clone Virtual Machine Wizard on page 270](#)
    - [Making a Linked Clone of a Linked Clone on page 273](#)
    - [Making a Full Clone of a Linked Clone on page 273](#)
  - [Working with Clones on page 273](#)
    - [Network Identity for a Clone on page 273](#)
    - [The Linked Clone Snapshot on page 274](#)
    - [Linked Clones and Access to the Parent Virtual Machine on page 274](#)
-

## Understanding Clones

A clone is a copy of an existing virtual machine. The existing virtual machine is called the parent of the clone. When the cloning operation is complete, the clone is a separate virtual machine — though it may share virtual disks with the parent virtual machine: see [Full and Linked Clones on page 269](#)).

- Changes made to a clone do not affect the parent virtual machine. Changes made to the parent virtual machine do not appear in a clone.
- A clone's MAC address and UUID are different from those of the parent virtual machine.

If you want to save the current state of the virtual machine, so you can revert to that state in case you make a mistake, take a snapshot. If you want to make a copy of a virtual machine for separate use, create a clone.

### Why Make a Clone?

Installing a guest operating system and applications can be time consuming. With clones, you can make many copies of a virtual machine from a single installation and configuration process.

Clones are useful when you must deploy many identical virtual machines to a group. For example:

- An MIS department can clone a virtual machine for each employee, with a suite of preconfigured office applications.
- A virtual machine can be configured with a complete development environment and then cloned repeatedly as a baseline configuration for software testing.
- A teacher can clone a virtual machine for each student, with all the lessons and labs required for the term.

With clones you can conveniently make complete copies of a virtual machine, without browsing a host file system or worrying if you have located all the configuration files.

## Full and Linked Clones

There are two types of clone:

- A full clone is an independent copy of a virtual machine that shares nothing with the parent virtual machine after the cloning operation. Ongoing operation of a full clone is entirely separate from the parent virtual machine.
- A linked clone is a copy of a virtual machine that shares virtual disks with the parent virtual machine in an ongoing manner. This conserves disk space, and allows multiple virtual machines to use the same software installation.

### Full Clones

A full clone is an independent virtual machine, with no need to access or maintain an ongoing connection to the parent virtual machine. Because a full clone does not share virtual disks with the parent virtual machine, full clones generally perform better than linked clones. However, full clones take longer to create than linked clones. Creating a full clone can take several minutes if the files involved are large.

### Linked Clones

A linked clone is made from a snapshot of the parent. (See [Understanding Snapshots on page 252](#).) All files available on the parent at the moment of the snapshot continue to remain available to the linked clone. Ongoing changes to the virtual disk of the parent do not affect the linked clone, and changes to the disk of the linked clone do not affect the parent.

A linked clone must access the parent. Without access to the parent, a linked clone is disabled. See [Linked Clones and Access to the Parent Virtual Machine on page 274](#)

Linked clones are created swiftly, so you can easily create a unique virtual machine for each task you have. You can also easily share a virtual machine with other users by storing the virtual machine on your local network, where other users can quickly make a linked clone. This facilitates collaboration: for example, a support team can reproduce a bug in a virtual machine, and an engineer can quickly make a linked clone of that virtual machine to work on the bug.

## Full Clones and Snapshots of the Parent

A full clone is a complete and independent copy of a virtual machine. However, the full clone duplicates only the state of the virtual machine at the instant of the cloning operation. Thus the full clone does not have access to any snapshots that may exist of the parent virtual machine.

## Creating Clones

This section discusses how to create a clone.

**Note:** Legacy virtual machines created under previous versions of Workstation (or under other VMware products) must be upgraded to Workstation 5 virtual machines before you can clone them. See [Procedure to Upgrade Virtual Machines on page 59](#).

### The Clone Virtual Machine Wizard

The Clone Virtual Machine Wizard guides through the process of making a clone. You do not need to locate and manually copy the parent virtual machine files. The Clone Virtual Machine Wizard automatically creates a new MAC address and other unique identifiers for the clone.

**Note:** You cannot create a clone from a virtual machine that is powered on or suspended. You must power off a virtual machine before you can make a clone.

To create a clone using the Clone Virtual Machine Wizard:

1. Select the virtual machine you want to clone.

Click the name of a virtual machine in the Favorites list or click the tab of a virtual machine in the summary window.

2. Open the Clone Virtual Machine Wizard (**VM > Clone**) and click **Next**.

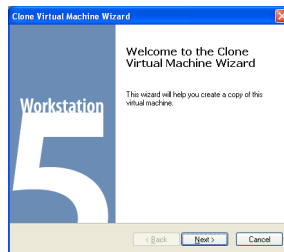

3. Select the state of the parent from which you want to create a clone, and click **Next**.

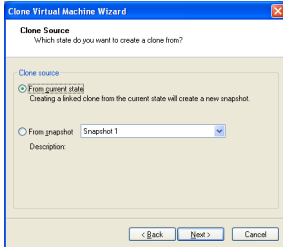

You can choose to create a clone from either of two states.

- From the parent's current state (Workstation creates a snapshot of the virtual machine before cloning it)
- From any snapshot of the parent: select the snapshot name from a drop-down menu of existing snapshots.

4. Select the type of clone you want to create and click **Next**.

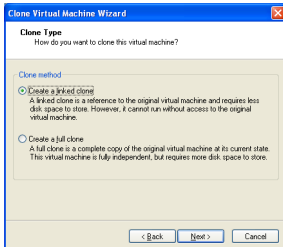

You can choose to make a full clone or a linked clone. See [Full and Linked Clones on page 269](#) for a description of the differences.

5. Type a name and a path for the cloned virtual machine, and click **Finish**.

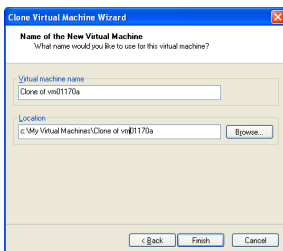

The default name and path are based on the original virtual machine name and location. You can type a new entry for name and path, or use the **Browse** button to locate a directory for the clone files.

After you have verified your entries, click **Finish**. The Clone Virtual Machine Wizard then displays a status page.

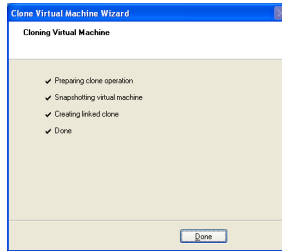

A full clone can take many minutes to create, depending on the size of the virtual disk that is being duplicated.

6. Click **Done** to exit the Clone Virtual Machine Wizard.



## Working with Clones

This section discusses the following topics:

- [Making a Linked Clone of a Linked Clone on page 273](#)
- [Making a Full Clone of a Linked Clone on page 273](#)
- [Network Identity for a Clone on page 273](#)
- [The Linked Clone Snapshot on page 274](#)
- [Linked Clones and Access to the Parent Virtual Machine on page 274](#)

### Making a Linked Clone of a Linked Clone

It is possible to make a linked clone from a linked clone, using the Clone Virtual Machine Wizard. Keep these cautions in mind:

- Performance degrades when you do this. When possible, make a linked clone of the parent virtual machine.
- To power on — and to work with — a linked clone of a linked clone, Workstation must be able to locate all ancestors in the chain. Refer to [Linked Clones and Access to the Parent Virtual Machine on page 274](#).

### Making a Full Clone of a Linked Clone

It is possible to make a full clone from a linked clone, using the Clone Virtual Machine Wizard.

- The linked clone can be used as before.
- The full clone created with this action is an independent virtual machine that does not require access to the linked clone or its ancestors.

**Note:** To make a full clone from a linked clone, Workstation must have access to the linked clone and all ancestors at the time you run the Clone Virtual Machine Wizard. Refer to [Linked Clones and Access to the Parent Virtual Machine on page 274](#).

### Network Identity for a Clone

The Clone Virtual Machine Wizard creates a new MAC address for the cloned virtual machine. Other configuration information is identical to that of the parent virtual machine. For example, a machine's name and static IP address configuration are not altered by the Clone Virtual Machine Wizard.

To prevent conflict with static IP addressing, change the clone's static IP before the clone connects to the network. Refer to [Selecting IP Addresses on a Host-only](#)

[Network or NAT Configuration on page 327](#) for a discussion regarding static IP address configuration.

## The Linked Clone Snapshot

When you create a linked clone, Workstation 5 creates a snapshot of the parent virtual machine. This snapshot preserves the exact state of the virtual machine when you create the clone.

**Caution:** You cannot delete this snapshot without destroying the linked clone. It is safe to delete this snapshot if you have deleted the clone depending on it.

The snapshot manager allows you to rename any snapshot. If you rename a snapshot for a cloned virtual machine, you may want to use the **Description** field to aid you in future identification. Refer to [The Snapshot Manager on page 258](#) for more information on renaming snapshots.

## Linked Clones and Access to the Parent Virtual Machine

You cannot power on — or resume — a linked clone if Workstation fails to locate the parent virtual machine. This section discusses the following topics:

- [Moving a Linked Clone on page 274](#)
- [Protecting the Parent of Linked Clones on page 275](#)

### Moving a Linked Clone

You can move a linked clone or its parent within a file system or network, but you must ensure VMware Workstation can continue to access the clone and the parent virtual machine. For example, place the parent in a shared directory or on a network file server so Workstation can use the linked clone from any host computer with network access.

See [Moving and Sharing Virtual Machines on page 169](#) for a discussion of moving virtual machines.

### Example: Using a Linked Clone on a Disconnected Laptop

If you put a linked clone on a laptop, and the parent remains on another machine, the clone can be used only when the laptop connects to the network or drive where the parent is stored. If you want to use a cloned virtual machine on a disconnected laptop, you must use a full clone or you must move the parent virtual machine to the laptop.

## Protecting the Parent of Linked Clones

To prevent anyone from deleting the parent virtual machine for a linked clone, you can designate the parent as a template. The two parts of the process are discussed in the following sections:

- [Enabling Template Mode for the Parent on page 275](#)
- [Creating a Linked Clone From a Template on page 276](#)

**Enabling Template Mode for the Parent** — You can avoid inadvertently deleting the parent of linked clones by designating the parent virtual machine as a template. To designate a virtual machine as a template, enable template mode in the virtual machine settings editor:

1. Select the virtual machine.
2. Choose **VM > Settings**
3. Select **Options**
4. Click **Advanced**
5. Select **Enable Template mode (to be used for cloning)**.

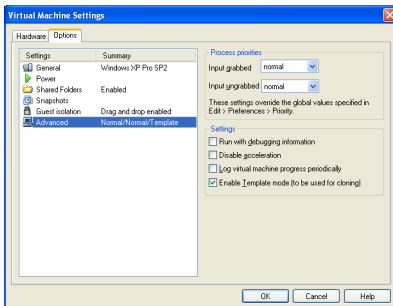

6. Click **OK**.

With template mode enabled, a virtual machine cannot be deleted or added to a team, and the virtual machine's snapshots cannot be deleted.

**Creating a Linked Clone From a Template** — When you create a linked clone of a template virtual machine, the Clone Virtual Machine Wizard includes several special options.

To create a linked clone from a template:

1. Select the virtual machine to use as a parent of your linked clone.
2. Verify that the parent has at least one snapshot. Open the snapshot manager and create a snapshot if none exists.
3. Verify that template mode has been enabled.

See [Protecting the Parent of Linked Clones](#) on page 275.

4. With the virtual machine still selected, launch the Clone Virtual Machine Wizard.
5. Click **Next** to display the **Clone Source** panel.
6. Select a snapshot from the drop-down menu and click **Next**.

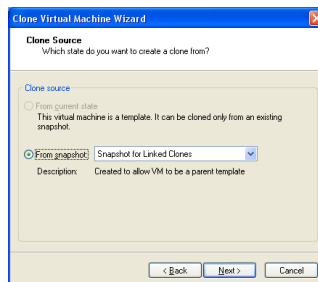

**Note:** The wizard does not allow you to clone from the current state when the virtual machine has template mode enabled.

7. Name the linked clone and click **Finish**.  
Workstation creates the linked clone and displays a status panel.
8. Click **Done** to exit the wizard.

# Configuring Teams

---

The following sections describe virtual machine teams:

- [Teams Overview on page 278](#)
- [Creating and Deleting Teams on page 279](#)
- [Adding and Removing Virtual Machines on page 286](#)
- [Starting and Stopping Teams on page 289](#)
- [Working with Team Networks on page 292](#)
- [The Startup Sequence on page 295](#)
- [Working with the Team Console View on page 296](#)
- [Editing Team Settings on page 298](#)
- [Command Line for Teams on page 303](#)

## Teams Overview

VMware Workstation teams allow you to set up a virtual computer lab on one host computer. You can now power on multiple associated virtual machines with a single click.

Team virtual machines can use networking just as other virtual machines can. In addition, team members can communicate in private networks called LAN segments. LAN segments are completely independent of — and invisible to — the host computer's network.

Team settings control the start-up order and timing for team virtual machines. you can set up specific delays between booting virtual machines so the host CPU load is spread out. Teams automatically launch virtual machines in the right order, with delays that you specify to ensure that each virtual machine stabilizes before the next virtual machine boots.

You can use teams to

- Virtualize multitier environments — Start separate client, server, and database virtual machines with one click. Configure start-up delay times so clients don't submit queries before the server is ready.
- Virtualize multiple-machine testing environments — Set up a software package for QA on a virtual machine, and configure automation on other virtual machines to test the first.
- Virtualize network performance and security — LAN segments offer enhanced performance and security. A team LAN segment is fully contained — undetectable and inaccessible from any other network, inside or outside the team. Team networking lets you
  - Isolate a team completely from the host network
  - Create a virtual DMZ or proxy server to securely bridge the team members to the outside network
  - Allow specific network bandwidth and packet loss to each virtual machine on the team
  - Connect all team members fully to host resources

You control all traffic allowed between the host network and team virtual machines

- Monitor multiple virtual machines — Use thumbnail views of the virtual machine displays to review activity on team virtual machines simultaneously.

# Creating and Deleting Teams

This section discusses the following topics:

- [Making a New Team on page 279](#)
- [Opening a Team on page 284](#)
- [Closing a Team on page 284](#)
- [Deleting a Team on page 285](#)

## Making a New Team

Use the New Team Wizard to create a team, then add virtual machines.

1. Open the New Team Wizard.

Choose **File > New > Team**.

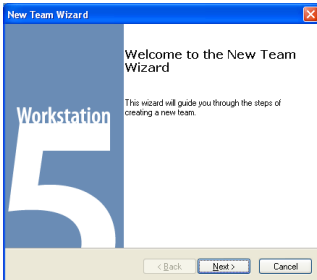

2. Click **Next** to confirm the wizard.
3. Type a name and path for the team and click **Next**.

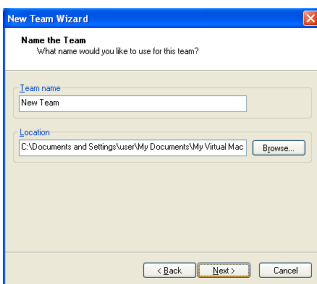

The default name and path are based on your default Virtual Machine location. You can type a new entry for name and path, or use the Browse button to find the directory where you want to store the team files.

After you have verified your entries, click **Next**.

4. If you wish, you can add virtual machines to your team.

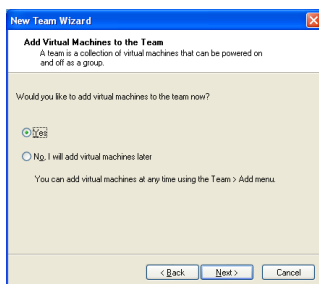

Click **Next**.

If you select **No, I will add virtual machines later**, skip to step 9.

If you select **Yes**, the wizard continues.

5. Click **Add** to add virtual machines to your team.

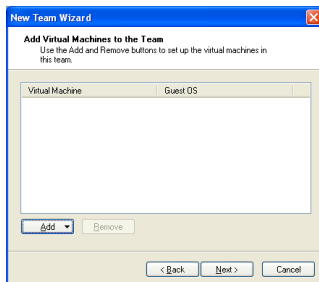

A drop-down menu appears, with three options.

- **New Virtual Machine** — Select this option to launch the New Virtual Machine Wizard. See [Steps to a New Virtual Machine on page 102](#).
- **Existing Virtual Machine** — Select this option to open a file browser from which you can navigate the host file system to locate an existing `.vmtx` file.

When you add a virtual machine to a team it can no longer be accessed outside the team. See [Adding an Existing Virtual Machine to a Team on page 286](#).



- **New Clone of Virtual Machine** — Select this option to open a file browser from which you can navigate the host file system to locate an existing `.vmtx` file. After you select a virtual machine, Workstation launches the Clone Virtual Machine Wizard. See [The Clone Virtual Machine Wizard on page 270](#).

Click **Next**.

6. If you wish, add LAN segments to your team.



If you select **No, I will add LAN segments later**, skip to step 9.

If you select **Yes**, the wizard continues.

For information about LAN segments, see [Working with Team Networks on page 292](#)

Click **Next**.

7. Click **Add** to create a LAN segment.

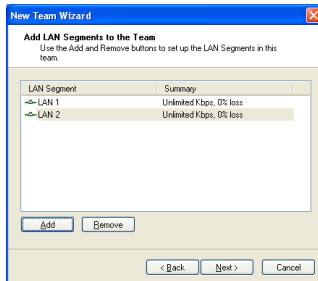

You can change default names and bandwidth later. See [LAN Segments on page 300](#) for the procedure.

Click **Next**.

8. Select the network connections for each virtual machine on the team.

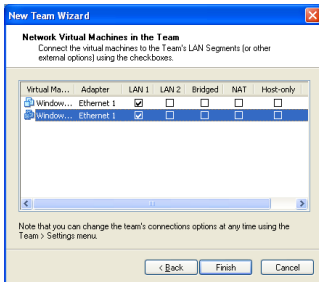

Select a network connection for each virtual machine Ethernet adapter. Each virtual machine can have one network connection per virtual Ethernet adapter.

- You can add or remove virtual Ethernet adapters later. See [Network Adapter on page 292](#) for more information.
  - You can change connections later. [Connecting to or Changing a LAN Segment](#) for the procedure.
9. Click **Finish** to exit the New Team Wizard.

## Opening a Team

To open a team in VMware Workstation:

1. Choose **File > Open**.
2. Browse to the location of the `.vmtm` file for the desired team.
3. Select the file and click **Open**.

The selected team appears as a tabbed item in the summary window. To add the team to the Favorites list, see [Adding an Item to the Favorites List on page 72](#).

## Closing a Team

Closing a team removes its summary window. The team and virtual machine members can no longer be seen in VMware Workstation, but you can open the team from the File menu. The team and virtual machine files remain on the host file system. To delete a team permanently, see [Deleting a Team on page 285](#).

To close a team

1. Make sure the team is powered off.
2. Select the team to close.  
Click the summary/console tab for the desired team, or select the team name in the favorites list.
3. Choose **File > Close**.

The closed team is removed from the summary window. To remove the team from the Favorites list, see [Removing an Item from the Favorites List on page 73](#).

## Deleting a Team

When you delete a team, you can choose to delete

- only the team (retaining the virtual machines in the team)
- the team and the virtual machines in the team

**Caution:** Deleting a team permanently removes the team files from the host file system and removes associated LAN segments from all virtual machines. Deleting the team's virtual machines along with the team removes the virtual machine files permanently.

To remove a team from the Workstation window without deleting the team, see [Closing a Team on page 284](#).

To delete a team permanently

1. Make sure the team is powered off.
2. Select the team to delete.  
Click the summary or console tab for the desired team, or select the team name in the Favorites list.
3. Choose **Team > Delete from Disk**.
4. To delete the team without deleting the virtual machines in it, choose **Delete**. To delete the team and the virtual machines in it, choose **Delete Team and VMs**.  
When you delete a team, you also delete all team LAN segments. The virtual ethernet adapters associated with deleted LAN segments become disconnected. Bridged, host-only, NAT and custom configurations remain unchanged.
5. Click **OK**.

The team is removed permanently from VMware Workstation and the host file system. If you chose **Delete Team and VMs** in step 4, the virtual machines in the team are also removed permanently from VMware Workstation and the host file system.

## Adding and Removing Virtual Machines

- [Adding an Existing Virtual Machine to a Team on page 286](#)
- [Removing a Virtual Machine from a Team on page 286](#)

### Adding an Existing Virtual Machine to a Team

To add an existing virtual machine to a team:

1. Select **Team > Add > Existing Virtual Machine**.  
A file open dialog box appears.
2. Browse to the folder with the `.vmtx` file for the virtual machine you want to add.
3. Select the `.vmtx` file and click **Open**.

The virtual machine is added to the team.

There are some issues to consider when you add a virtual machine to a team.

- A virtual machine is not powered on when you add it to a running team. You must power on the added virtual machine manually to use it during the current session. However, the added virtual machine is thereafter powered on or off with the rest of the team.
- When you add a virtual machine to a team, you can no longer operate the virtual machine outside the team. Adding a virtual machine to a team therefore removes it from the Favorites list.

### Removing a Virtual Machine from a Team

To remove a virtual machine from a team

1. Select the team with the virtual machine you want to remove.  
Click the summary or console tab for the desired team, or select the team name in the Favorites list.
2. Choose **Team > Remove > <virtual machine name>**.

The selected virtual machine is removed from the team. You can now use it independently

**Note:** When you remove a virtual machine from a team, you also remove it from team LAN segments. Virtual network adapters associated with LAN segments become disconnected. Bridged, host-only, NAT and vmnet configurations remain unchanged. If you want to completely delete a virtual machine and erase its files from the host file system, see [Deleting a Virtual Machine on page 148](#).

### **Teams and the Favorites List**

When you add a virtual machine to a team, it is automatically deleted from the Favorites list. However, a virtual machine is not automatically added to the Favorites list when you remove it from a team. You must manually add a virtual machine to the Favorites list after removing it from a team. See [Adding an Item to the Favorites List](#).

# Cloning and Taking Snapshots of Team Members

## Cloning a Virtual Machine in a Team

You can clone a virtual machine in a team in the same way you clone any other virtual machine. See [Creating Clones on page 270](#). When you clone a virtual machine in a team

- The resulting clone is not part of the team.
- The clone automatically appears on the Favorites list as well as in a summary window.
- If the parent virtual machine is configured for a LAN segment, the virtual Ethernet adapter for that LAN segment on the clone is disconnected. To connect to a network, you must reconfigure the virtual Ethernet adapter manually.

## Taking Snapshots of Individual Virtual Machines in a Team

Snapshots operate on virtual machines, not on the whole team. When a team is active, the **Snapshot** button on the toolbar takes a snapshot of only the active virtual machine.

If you want to preserve the state of all virtual machines on a team, power off the team, then take a snapshot of each virtual machine before you power on the team again.



# Starting and Stopping Teams

Power operations for teams are much the same as those for an individual virtual machine. However, for a team, you can also configure the sequence in which the members of a team power on and off. See [Changing the Start-Up Sequence for a Team on page 299](#).

- [Powering On a Team on page 289](#)
- [Powering Off a Team on page 289](#)
- [Suspending a Team on page 289](#)
- [Resuming a Team on page 290](#)

**Note:** You cannot close VMware Workstation if a team is powered on.

## Powering On a Team

To power on a team

1. Select the team to power on: select the team from the Favorites list, or click the summary tab for the team.
2. Click the Power On button on the toolbar.

The team begins to power on in the sequence specified in **Team > Settings**. See [The Startup Sequence on page 295](#) for more information.

## Powering Off a Team

To power off a team

1. Select the team to power off: select the team from the Favorites list, or click the summary tab for the team.
2. Click the Power Off button on the toolbar.

The team begins to power off in the sequence specified in **Team > Settings**. See [The Startup Sequence on page 295](#) for more information.

## Shutting Down a Virtual Machine When You Power Off a Team

When you power off a team, the default settings for a virtual machine can cause the guest operating system to terminate abruptly. For information about configuring your virtual machine to recognize the shut down guest command when you power off a team, see [Shutting Down a Virtual Machine on page 144](#).

## Suspending a Team

When you suspend a team, the virtual machines in the team are suspended.

To suspend a team of virtual machines

1. Select the team to suspend: select the team from the Favorites list, or click the summary tab for the team.
2. Click the Suspend button on the toolbar.

All team virtual machines start suspending simultaneously. A progress indicator appears for each team member. To see the progress of a particular team member, choose **Team > Switch To > <virtual machine name>**.

The time to complete the operation varies with the size of the virtual machines.

## Resuming a Team

To resume a team of virtual machines

1. Select the team to resume: select the team from the Favorites list, or click the summary tab for the team.
2. Click the Power On button on the toolbar.

A progress indicator appears. The time to complete the operation varies with the size of the virtual machines.

The startup sequence determines the order in which virtual machines are suspended and resumed, and the time Workstation delays after each team member is resumed, before resuming the next team member. See [Changing the Start-Up Sequence for a Team on page 299](#).

**Note:** If you attempt to close VMware Workstation while the team suspend/resume operation is still in progress, a warning dialog appears.

## Power Operations for Individual Members of a Team

To perform power operations for a single virtual machine in a team

1. Select the virtual machine from the teams console.
2. Choose the appropriate command from the **VM > Power** menu.
  - Power On — see [Starting a Virtual Machine on page 141](#) for a description. This command starts the active virtual machine, just as a power switch starts a physical PC.
  - Power Off — see [Shutting Down a Virtual Machine on page 144](#) for a description. This command turns off the active virtual machine, just as a power switch turns off a physical PC.

**Caution:** If a virtual machine is writing to disk when it receives a Power Off command, data may be corrupted. See [Shutting Down a Virtual Machine on page 144](#) for more information.

- Suspend and Resume — see [Suspending and Resuming Virtual Machines on page 143](#) for a description.
- Reset — see [Resetting a Virtual Machine on page 145](#) for a description. This command resets the active virtual machine, just as pressing the hardware reset button resets a physical PC.

**Caution:** If a virtual machine is writing to disk when it receives a reset command, data may be corrupted. See [Resetting a Virtual Machine on page 145](#) for more information.

- Shut Down Guest — This command sends a shut down signal to the guest operating system. Some guest operating systems do not respond to this command.
- Restart Guest — This command sends a restart signal to the guest operating system. Some guest operating systems do not respond to this command.
- Suspend after running script — This command prompts you for a script to execute before suspending the guest operating system. See [Command Line Reference on page 91](#) for information about scripts.
- Resume and run script — This command prompts you for a script to execute after resuming the guest operating system. See [Command Line Reference on page 91](#) for information about scripts.
- Power on and run script — This command prompts you for a script to execute after powering on the guest operating system. See [Command Line Reference on page 91](#) for information about scripts.

## Working with Team Networks

One of the special advantages of teams is the ability to isolate virtual machines in private virtual networks, called LAN segments. This can be useful with multitier testing, network performance analysis, and situations where isolation and packet loss are important.

### LAN Segment Requirements

The following sections describe the requirements for virtual machines connecting to a LAN segment.

#### Network Adapter

A physical PC must have a network adapter for each physical network connection. Similarly, a virtual machine must be configured with a virtual network adapter for each LAN segment it interacts with. To connect a virtual machine to multiple LAN segments simultaneously, you must configure that virtual machine with multiple network adapters.

#### LAN Segment IP Addresses

Each network client must have an IP address for TCP/IP networking. Unlike host-only and NAT networking, LAN segments have no DHCP server provided automatically by VMware Workstation. Therefore you must manually configure IP addressing for team virtual machines on a LAN segment. There are two choices.

- **DHCP** — Configure a DHCP server on your LAN segment to allocate IP addresses to your virtual machines.
- **Static IP** — Configure a fixed IP address for each virtual machine on the LAN segment.

**Note:** When you add an existing virtual machine to a team, the virtual machine may be configured to expect an IP address from a DHCP server. A DHCP server is not automatically provided for a virtual LAN segment. You must provide a DHCP server on the LAN segment, or reconfigure the virtual machine to use a static IP address. See [Configuring a Virtual Network on page 305](#).

## Creating a Team LAN Segment

To create a virtual network for a team:

1. Choose **Team > Add > LAN Segment**.
2. Enter a name for the private network.

The LAN segment is added to the team.

## Connecting to or Changing a LAN Segment

To connect a virtual machine to a LAN segment:

1. Choose **Team > Settings**

The team settings editor opens to the Connections tab. Each virtual Ethernet adapter is displayed in a separate row.

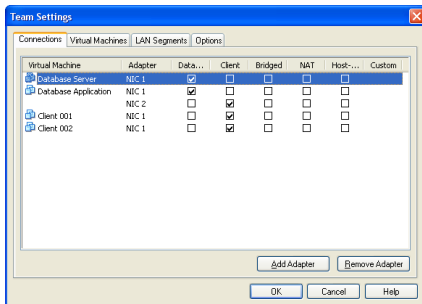

2. For each virtual Ethernet adapter, select a LAN segment.  
Check one box on each row to set the type of network connection for that virtual Ethernet adapter.
3. Click **OK**.

The virtual machine is now connected to the selected LAN segment.

## Renaming a LAN Segment

To rename an existing LAN segment

1. Choose **Team > Settings**
2. Click **LAN Segments**.

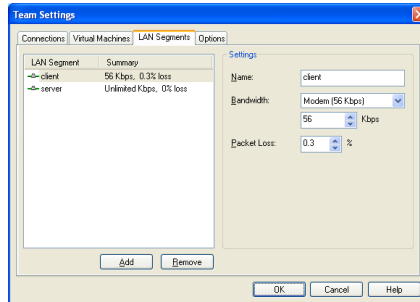

3. Select the LAN segment you want to rename.
4. Type a new name in the **Name** field.
5. Click **OK**.

The LAN segment now has the new name.

## Deleting a LAN Segment

To delete a LAN segment from a team:

1. Choose **Team > Settings**
2. Click the **LAN Segments** tab.
3. Select the LAN segment you want to delete.
4. Click **Remove**.

The LAN segment is removed.

**Note:** Deleting a LAN segment disconnects all virtual Ethernet adapters that are configured for that LAN segment. When you remove a virtual machine from a team, you must manually configure its disconnected virtual Ethernet adapter if you want to reconnect the virtual machine to a network.

# The Startup Sequence

In the start-up sequence, you can specify

- The order in which team virtual machines start and stop — Team virtual machines start one at a time, in the order you set in the start-up sequence. Setting the start-up sequence is useful, for example, if you have a virtual machine that runs an application to be tested and you want it to start before the virtual machines running an automated testing script.
- The delay between team members in the sequence — You can set the time that Workstation delays after starting or stopping a virtual machine, before starting or stopping the next virtual machine in the sequence. This delay can be useful to reduce the load on the host CPU, and to allow applications on a virtual machine to launch before another team virtual machine attempts to connect.

The start-up sequence applies to power on, power off, suspend, and resume operations.

- Power on and resume operations for virtual machines occur in the order of the sequence shown in the team settings list.
- Power off and suspend operations for virtual machines occur in the reverse of the order shown in the team settings list.

To set the start-up sequence for a team, see [Changing the Start-Up Sequence for a Team on page 299](#).

## Understanding the Start-Up Sequence Delay

You can set a delay between the sequential start-ups of virtual machines in a team. This delay is useful to avoid overloading the CPU when multiple team virtual machines start. You might also use this delay to ensure that a virtual machine functioning as a server completes its start-up before client virtual machines start.

If your virtual machine team depends on precise start-up timing, you may need to experiment to determine how much time your host and guest operating environments and applications need to launch.

## Working with the Team Console View

The team console view shows each virtual machine in the team. From the team console view, you can select any team virtual machine to work with.

### Displaying Teams

VMware Workstation displays teams in a summary view or console view.

- The summary view is available at any time. See [Displaying the Summary View on page 66](#) for more information about the summary view
- The console view is available only when a team is powered on. The console view displays the team in two areas. The main part of the display shows the active virtual machine. The area just below the Workstation summary tabs shows thumbnail views of all virtual machines in the team. A grab bar allows you to resize the areas.

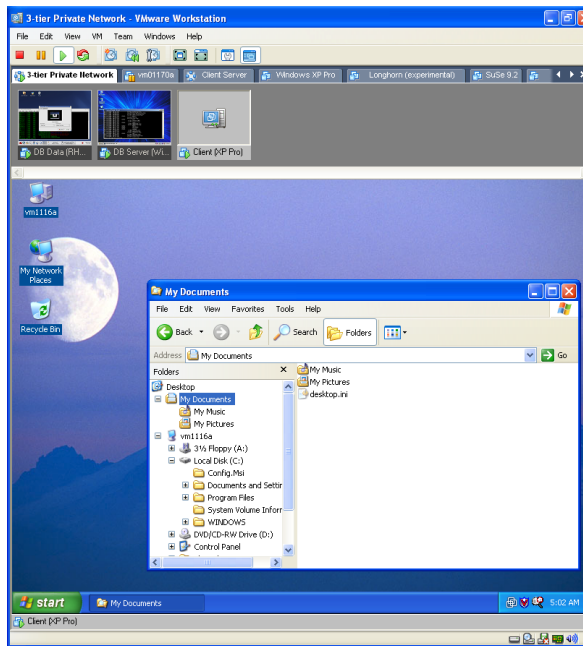

Console window for a team (Windows host)



## **The Active Virtual Machine**

### **Team Thumbnails**

When a team is powered on, the team console displays thumbnail views of all team members in a row at the top of the console. You may have to scroll the thumbnails to view all your virtual machines on a large team. The thumbnails are displayed in the same order as the team's start-up sequence, starting on the left with the first virtual machine in the sequence.

Workstation updates thumbnails in real time, to display the actual content of the virtual machine screens. The active virtual machine — the one appearing in the lower pane of the console — is represented by the VMware icon.

Workstation menus and commands directly affect only the active virtual machine, and you can use the mouse and keyboard to interact directly with the active virtual machine.

### **Changing the Active Virtual Machine**

Click a thumbnail of a virtual machine to make the virtual machine active. The virtual machine you clicked appears in the lower pane of the console, and its thumbnail becomes the VMware icon.

### **Using Full Screen with Teams**

In full screen mode, Workstation displays only the active virtual machine. See [Using Full Screen Mode on page 150](#).

## Editing Team Settings

To review or change team properties, choose **Team > Settings**. You can configure the virtual machines in the team, review the team LAN segments, or rename the team using the following tabs:

- [Connections](#)
- [Virtual Machines](#)
- [LAN Segments](#)
- [Options](#)

### Connections

To review and configure network connections

1. Choose **Team > Settings**.
2. Click **Connections**.

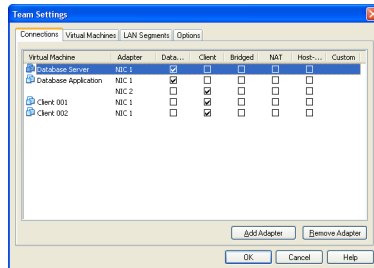

From this tab you can review the virtual machine name, guest operating system, and network and LAN segment associations for each member of the team. You can also change network settings from this screen.

## Virtual Machines

To change the start-up sequence and delay

1. Choose **Team > Settings**.
2. Click **Virtual Machines**.

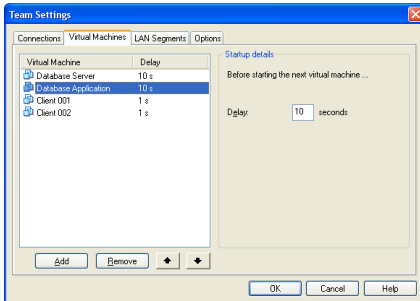

From this tab you can add and remove virtual machines, and change the virtual machine startup sequence.

The list of virtual machines associated with the team is displayed on the left, in the order of the start-up sequence: the virtual machine at the top of the list is the first in the start-up sequence; the virtual machine at the bottom of the list is the last in the sequence.

### Changing the Start-Up Sequence for a Team

To set the start-up sequence for members of a team

1. Choose **Team > Settings**.
2. Click **Virtual Machines**.
3. Arrange the virtual machine start order.

Select any virtual machine and use the **Up** or **Down** buttons to change the sequence.

4. Set the delay time between virtual machines.

Under Startup details you can set a delay time between each virtual machine and the next virtual machine in the start-up sequence. This delay is applied to power on, power off, suspend, and resume operations. The default delay is 10 seconds.

To change the delay, use the up and down arrows or type a number into the field. See [Understanding the Start-Up Sequence Delay on page 295](#) for a discussion of this option.

5. Click **OK**

Your changes are saved.

**Note:** The start-up sequence applies to team suspend and resume operations as well as power on and power off operations:

- Team virtual machines power off and suspend in the reverse order of the start-up sequence, with the delays you set in Startup details.
- Team virtual machines power on and resume in the order of the sequence, with the delays you set in Startup details.

## LAN Segments

To configure LAN segments

1. Choose **Team > Settings**.
2. Click **LAN Segments**.

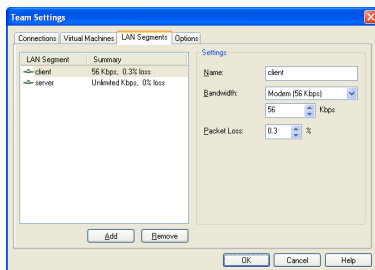

From this tab you can add, remove, and rename the LAN segments configured for the team. You can also configure network transmission properties for the LAN segment from this tab.

The list in the left pane displays LAN segments associated with the team. Click a name to select the LAN segment you want to configure.

The right pane displays parameters for the physical properties of the emulated LAN segment link.

- **Name** — The name of the LAN segment.  
To change the name, type a new name in the **Name** field.
- **Bandwidth** — A drop-down menu of bandwidths for typical network links.  
To change the bandwidth by connection type, choose another connection type from the drop-down menu.

- **Kbps** — In this field you can set a custom bandwidth — one that is different from the choices in the Bandwidth menu. Changes here are overwritten when you make a selection from the **Bandwidth** menu.

To change the bandwidth, type a number into the field.

- **Packet Loss** — A specification of the efficiency or faultiness of the link, measured in the percentage of packets lost from the total number of packets transmitted.

To change the packet loss setting, type a number into the field.

Click **OK** to save your changes. Click **Cancel** to discard your changes.

**Note:** LAN settings changes are ignored by virtual machines that are currently running. Changes to LAN settings become active for a given virtual machine only after that virtual machine is powered on, reset, or resumed.

## Options

To change the name of a team

1. Choose **Team > Settings**.
2. Click **Options**.

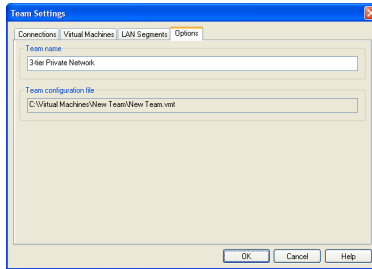

3. Type a new name in the **Team name** field.
4. Click **OK**.

## **Command Line for Teams**

VMware Workstation now includes a command line application for scripting certain operations for teams. See [Command Line Application on page 93](#) for more information.





# Configuring a Virtual Network

---

The first topics in this section give you a quick look at the virtual networking components that VMware Workstation provides and show how you can use them with your virtual machine. The rest of the section provides more detail on some networking capabilities and specialized configurations.

- [Network Basics on page 306](#)
- [Components of the Virtual Network on page 307](#)
- [Common Networking Configurations on page 309](#)
- [Custom Networking Configurations on page 313](#)
- [Changing the Networking Configuration on page 316](#)
- [Advanced Networking Topics on page 326](#)
- [Understanding NAT on page 345](#)
- [Using Samba with Workstation on page 358](#)

## Network Basics

VMware Workstation provides several ways you can configure a virtual machine for virtual networking.

- Bridged networking configures your virtual machine as a unique identity on the network, separate and unrelated to its host. See [Bridged Networking on page 309](#).
- Network address translation (NAT) configures your virtual machine to share the IP and MAC addresses of the host. The virtual machine and the host share a single network identity that is not visible outside the network. NAT can be useful when you are allowed a single IP address or MAC address by your network administrator. You might also use NAT to configure separate virtual machines for handling http and ftp requests, with both virtual machines running off the same IP address or domain. See [Network Address Translation \(NAT\) on page 310](#).
- Host-only networking configures your virtual machine to allow network access only to the host. This can be useful when you want a secure virtual machine that is connected to the host network, but available only through the host machine. See [Host-Only Networking on page 312](#).
- Custom networking lets you configure your virtual machine's network connection manually.

If you select the **Typical** setup path in the New Virtual Machine Wizard when you create a virtual machine, the wizard sets up bridged networking for the virtual machine. You can choose any of the common configurations — bridged networking, network address translation (NAT), and host-only networking — by selecting the **Custom** setup path. The wizard then connects the virtual machine to the appropriate virtual network.

You can set up more specialized configurations by choosing the appropriate settings in the virtual machine settings editor, in the virtual network editor (on Windows hosts), and on your host computer.

On a Windows host, the software needed for all networking configurations is installed when you install VMware Workstation. On a Linux host, when you install Workstation, you can choose whether to have bridged and host-only networking available to your virtual machines: you must choose both options during the Workstation installation to make all networking configurations available for your virtual machines.

# Components of the Virtual Network

The following sections describe the devices that make up a virtual network.

## Virtual switch

Like a physical switch, a virtual switch lets you connect other networking components together. Virtual switches are created as needed by the VMware Workstation software, up to a total of nine switches. You can connect one or more virtual machines to a switch.

By default, a few of the switches and the networks associated with them are used for special named configurations:

- The bridged network uses VMnet0.
- The host-only network uses VMnet1.
- The NAT network uses VMnet8.

The other available networks are simply named VMnet2, VMnet3, VMnet4, and so on.

To connect a virtual machine to a switch: In the virtual machine settings editor, select the virtual network adapter to connect, and then configure the adapter to use the desired virtual network.

## Bridge

The bridge lets you connect your virtual machine to the LAN used by your host computer. It connects the virtual network adapter in your virtual machine to the physical Ethernet adapter in your host computer.

The bridge is installed during VMware Workstation installation (on a Linux host, you must choose to make bridged networking available to your virtual machines). When you create a new virtual machine using bridged networking, the bridge is set up automatically.

You can set up additional virtual bridges for custom configurations that require connections to more than one physical Ethernet adapter on the host computer.

## Host Virtual Adapter

The host virtual adapter is a virtual Ethernet adapter that appears to your host operating system as a VMware virtual Ethernet adapter on a Windows host and as a host-only interface on a Linux host. The host virtual adapter allows you to communicate between your host computer and the virtual machines on that host computer. The host virtual adapter is used in host-only and NAT configurations.

The host virtual adapter is not connected to any external network unless you set up special software on the host computer — a proxy server, for example — to connect the host-only adapter to the physical network adapter.

The software that creates the host virtual adapter is installed when you install VMware Workstation (on a Linux host, you must choose to make host-only networking available to your virtual machines). A host virtual adapter is then created automatically when you boot the host computer.

You can set up additional host virtual adapters as needed.

## NAT Device

The NAT (network address translation) device allows you to connect your virtual machines to an external network when you have only one IP network address on the physical network, and that address is used by the host computer. You can, for example, use NAT to connect your virtual machines to the Internet through a dial-up connection on the host computer, through the host computer's Ethernet adapter, or (for Windows only) through a wireless Ethernet adapter. NAT is also useful when you need to connect to a non-Ethernet network, such as Token Ring or ATM.

The NAT device is set up automatically when you install VMware Workstation. (On a Linux host, you must choose to make NAT available to your virtual machines.)

## DHCP Server

The DHCP (dynamic host configuration protocol) server provides IP network addresses to virtual machines in configurations that are not bridged to an external network — for example, host-only and NAT configurations.

## Network Adapter

One virtual network adapter is set up for your virtual machine when you create it with the New Virtual Machine Wizard using any type of networking. It appears to the guest operating system as an AMD PCNET PCI adapter.

You can create and configure up to three virtual network adapters in each virtual machine using the virtual machine settings editor.

## Common Networking Configurations

The following sections illustrate the networking configurations that are set up for you automatically when you choose the standard networking options in the New Virtual Machine Wizard or virtual machine settings editor.

Only one virtual machine is shown in each example, but multiple virtual machines can be connected to the same virtual Ethernet switch. On a Windows host, you can connect an unlimited number of virtual network devices to a virtual switch. On a Linux host, you can connect up to 32 devices.

### Bridged Networking

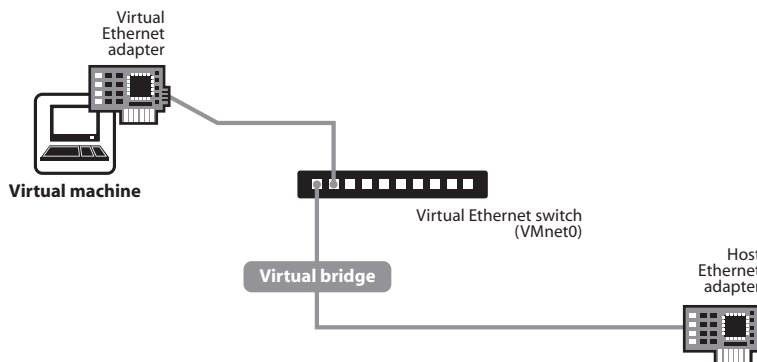

*Bridged networking connects a virtual machine to a network using the host computer's Ethernet adapter.*

Bridged networking is set up automatically if you select **Use bridged networking** in the New Virtual Machine Wizard or if you select the **Typical** setup path. This selection is available on a Linux host only if you enable the bridged networking option when you install VMware Workstation.

If your host computer is on an Ethernet network, this is often the easiest way to give your virtual machine access to that network. Linux and Windows hosts can use bridged networking to connect to a wired network. Additionally, wireless network bridging is supported for Windows hosts.

If you use bridged networking, your virtual machine needs to have its own identity on the network. For example, on a TCP/IP network, the virtual machine needs its own IP address. Your network administrator can tell you whether IP addresses are available for your virtual machine and what networking settings you should use in the guest operating system. Generally, your guest operating system may acquire an IP address

and other network details automatically from a DHCP server, or you may need to set the IP address and other details manually in the guest operating system.

If you use bridged networking, the virtual machine is a full participant in the network. It has access to other machines on the network and can be contacted by other machines on the network as if it were a physical computer on the network.

Be aware that if the host computer is set up to boot multiple operating systems and you run one or more of them in virtual machines, you need to configure each operating system with a unique network address. People who boot multiple operating systems often assign all systems the same address, since they assume only one operating system will be running at a time. If you use one or more of the operating systems in a virtual machine, this assumption is no longer true.

If you make some other selection in the New Virtual Machine Wizard and later decide you want to use bridged networking, you can make that change in the virtual machine settings editor (**VM > Settings**). For details, see [Changing the Networking Configuration on page 316](#).

## Network Address Translation (NAT)

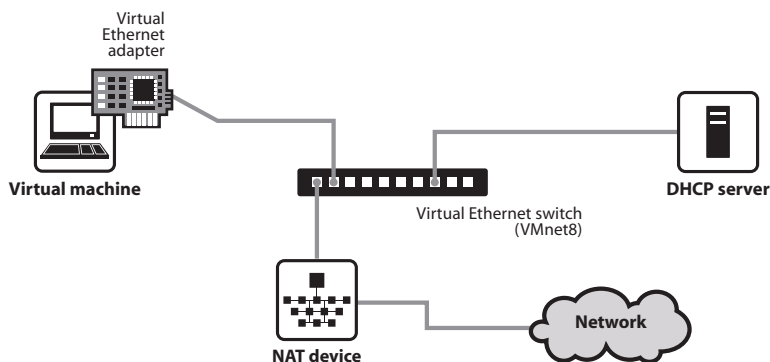

*NAT gives a virtual machine access to network resources using the host computer's IP address.*

A network address translation connection is set up automatically if you follow the **Custom** path in the New Virtual Machine Wizard and select **Use network address translation**.

If you want to connect to the Internet or other TCP/IP network using the host computer's dial-up networking or broadband connection and you are not able to give your virtual machine an IP address on the external network, NAT is often the easiest way to give your virtual machine access to that network.

NAT also allows you to connect to a TCP/IP network using a Token Ring adapter on the host computer.

If you use NAT, your virtual machine does not have its own IP address on the external network. Instead, a separate private network is set up on the host computer. Your virtual machine gets an address on that network from the VMware virtual DHCP server. The VMware NAT device passes network data between one or more virtual machines and the external network. It identifies incoming data packets intended for each virtual machine and sends them to the correct destination.

If you select NAT, the virtual machine can use many standard TCP/IP protocols to connect to other machines on the external network. For example, you can use HTTP to browse Web sites, FTP to transfer files and Telnet to log on to other computers. In the default configuration, computers on the external network cannot initiate connections to the virtual machine. That means, for example, that the default configuration does not let you use the virtual machine as a Web server to send Web pages to computers on the external network.

If you make some other selection in the New Virtual Machine Wizard and later decide you want to use NAT, you can make that change in the virtual machine settings editor (**VM > Settings**). For details, see [Changing the Networking Configuration on page 316](#).

## Host-Only Networking

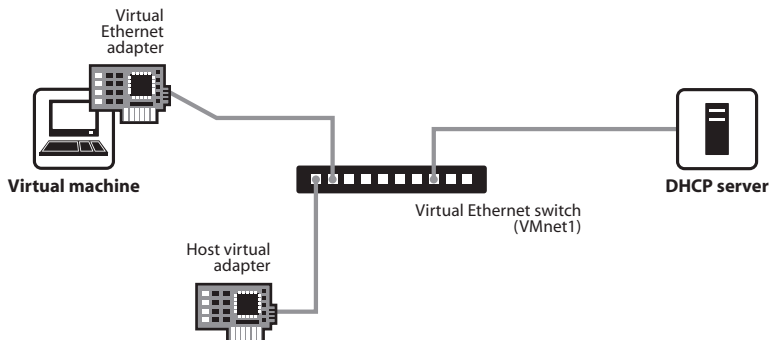

*Host-only networking creates a network that is completely contained within the host computer.*

A host-only network is set up automatically if you select **Use Host-only Networking** in the New Virtual Machine Wizard. On Linux hosts, this selection is available only if you enabled the host-only networking option when you installed VMware Workstation.

Host-only networking provides a network connection between the virtual machine and the host computer, using a virtual Ethernet adapter that is visible to the host operating system. This approach can be useful if you need to set up an isolated virtual network.

If you use host-only networking, your virtual machine and the host virtual adapter are connected to a private Ethernet network. Addresses on this network are provided by the VMware DHCP server.

If you make some other selection in the New Virtual Machine Wizard and later decide you want to use host-only networking, you can make that change in the virtual machine settings editor (**VM > Settings**). For details, see [Changing the Networking Configuration on page 316](#).

### Routing and Connection Sharing

If you install the proper routing or proxy software on your host computer, you can establish a connection between the host virtual Ethernet adapter and a physical network adapter on the host computer. This allows you, for example, to connect the virtual machine to a Token Ring or other non-Ethernet network.

On a Windows 2000, Windows XP or Windows Server 2003 host computer, you can use host-only networking in combination with the Internet connection sharing feature in Windows to allow a virtual machine to use the host's dial-up networking adapter or other connection to the Internet. See your Windows documentation for details on configuring Internet connection sharing.



## Custom Networking Configurations

The virtual networking components provided by VMware Workstation make it possible for you to create sophisticated virtual networks. The virtual networks can be connected to one or more external networks, or they may run entirely on the host computer.

Setting up networking components for your custom virtual network is a straightforward process. Before attempting to set up complex virtual networks, you should have a good understanding of how to configure network devices in your host and guest operating systems.

The sample configuration described in this section illustrates many of the ways you can combine devices on a virtual network. Other custom configurations are described in [Advanced Networking Topics on page 326](#) and [Understanding NAT on page 345](#).

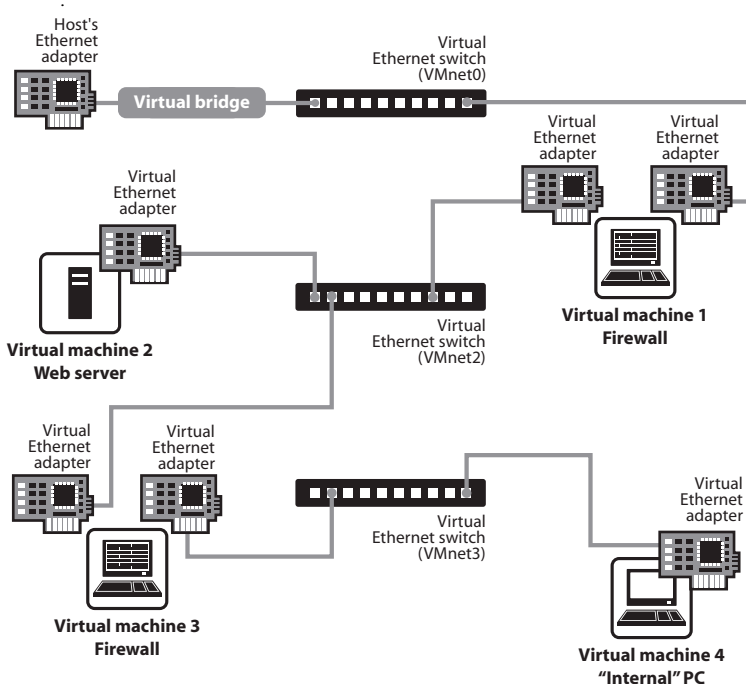

*In this custom configuration, a Web server connects through a firewall to an external network. An administrator's computer can connect to the Web server through a second firewall.*

To set up this configuration, you must create four virtual machines and use the virtual machine settings editor to adjust the settings for their virtual Ethernet adapters. You also need to install the appropriate guest operating systems and application software in each virtual machine and make the appropriate networking settings in each virtual machine.

1. Set up four virtual machines using the New Virtual Machine Wizard.

Create the first virtual machine with bridged networking so it can connect to an external network using the host computer's Ethernet adapter.

Create the other three virtual machines without networking. You will set up their virtual Ethernet adapters in later steps.

2. Start VMware Workstation and open virtual machine 1. Do not power on the virtual machine.

Use the virtual machine settings editor (**VM > Settings**) to add a second virtual network adapter, as described in [Changing the Networking Configuration on page 316](#). Connect the second adapter to **Custom (VMnet2)**.

Click **OK** to save the configuration and close the virtual machine settings editor.

3. If VMware Workstation is not running, start it. Open virtual machine 2. Do not power on the virtual machine.

Use the virtual machine settings editor (**VM > Settings**) to add a virtual network adapter. Connect the adapter to **Custom (VMnet2)**.

Click **OK** to save the configuration and close the virtual machine settings editor.

4. If VMware Workstation is not running, start it. Open virtual machine 3. Do not power on the virtual machine.

Use the virtual machine settings editor (**VM > Settings**) to add a virtual network adapter. Connect the adapter to **Custom (VMnet2)**.

Use the virtual machine settings editor to add a second virtual network adapter. Connect the adapter to **Custom (VMnet3)**.

Click **OK** to save the configuration and close the virtual machine settings editor.

5. If VMware Workstation is not running, start it. Open virtual machine 4. Do not power on the virtual machine.

Use the virtual machine settings editor (**VM > Settings**) to add a virtual network adapter. Connect the adapter to **Custom (VMnet3)**.

Click **OK** to save the configuration and close the virtual machine settings editor.

- Determine the network addresses used for VMnet2 and VMnet3.

**Note:** On a Windows host, you may skip the steps for configuring network addresses manually and, instead, use Workstation's DHCP server. Go to **Edit > Virtual Network Settings > DHCP** and add VMnet2 and VMnet3 to the list of virtual networks served by the virtual DHCP server. Then skip to step 9.

On a Windows host, open a command prompt on the host computer and run `ipconfig /all`. Note the network addresses used by each virtual adapter.

On a Linux host, run `ifconfig` at the console or in a terminal window on the host computer. Note the network addresses used by each virtual switch.

- Start VMware Workstation, open each virtual machine in turn and install the appropriate guest operating system.
- Configure the networking in each guest operating system.

For the bridged Ethernet adapter in virtual machine 1, use the networking settings needed for a connection to the external network. If the virtual machine gets its IP address from a DHCP server on the external network, the default settings should work.

For the second Ethernet adapter in virtual machine 1, manually assign an IP address in the range you are using with VMnet2.

In virtual machine 2, assign an IP address in the range you are using with VMnet2.

In virtual machine 3, network adapters are connected to VMnet2 and VMnet3. Assign each adapter an IP address in the range you are using with the virtual network to which it is connected.

In virtual machine 4, assign an IP address in the range you are using with VMnet3.

- Install the necessary application software in each virtual machine.

# Changing the Networking Configuration

Using the virtual machine settings editor (**VM > Settings**), you can add virtual Ethernet adapters to your virtual machine and change the configuration of existing adapters. This sections contains the following topics:

- [Adding and Modifying Virtual Network Adapters on page 316](#)
- [Configuring Bridged Networking Options on a Windows Host on page 318](#)
- [Enabling, Disabling, Adding and Removing Host Virtual Adapters on page 323](#)

## Adding and Modifying Virtual Network Adapters

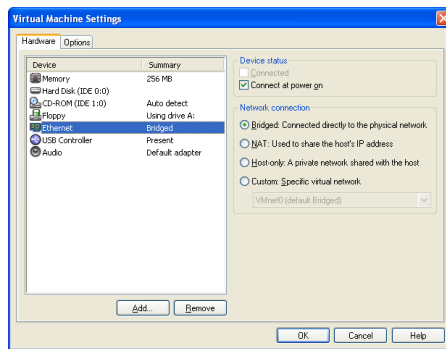

To add a new virtual Ethernet adapter, follow these steps.

1. Be sure the virtual machine to which you want to add the adapter is powered off.
2. Open the virtual machine settings editor (**VM > Settings**).
3. Click **Add**.
4. The Add Hardware Wizard starts. Select **Network Adapter**. Click **Next**.
5. Select the network type you want to use — **Bridged**, **NAT**, **Host-only** or **Custom**.
6. If you select **Custom**, choose the VMnet network you want to use from the drop-down list.
 

**Note:** Although VMnet0, VMnet1 and VMnet8 are available in this list, they are normally used for bridged, host-only and NAT configurations, respectively. Special steps are required to make them available for use in custom configurations. You should choose one of the other switches.
7. Click **Finish**. The new adapter is added.
8. Click **OK** to save your configuration and close the virtual machine settings editor.

To change the configuration of an existing virtual network adapter, follow these steps.

1. Open the virtual machine settings editor (**VM > Settings**).
2. Select the adapter you want to modify.
3. Select the network type you want to use — **Bridged, NAT, Host-only** or **Custom**.
4. If you select **Custom**, choose the VMnet virtual network you want to use for the network from the drop-down list.
5. Click **OK** to save your changes and close the virtual machine settings editor.
6. Be sure the guest operating system is configured to use an appropriate IP address on the new network. If the guest is using DHCP, release and renew the lease. If the IP address is set statically, be sure the guest has an address on the correct virtual network.

## Configuring Bridged Networking Options on a Windows Host

**Note:** The virtual network editor is not available on a Linux host.

Use the virtual network editor to configure bridged networking. You can

- View and change the settings for bridged networking on your host
- Determine which network adapters on your host to use for bridged networking
- Map specific network adapters to specific virtual networks, called VMnets

**Note:** The changes you make to bridged networking affect all virtual machines using bridged networking on the host.

### Configuring VMnet0 Bridged Networking

1. Choose **Edit > Virtual Network Settings**.

The virtual network editor appears, with the Summary tab active.

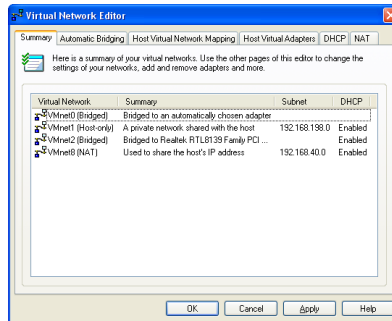

By default, the VMnet0 virtual network is set up in bridged mode and bridges to one of the active Ethernet adapters on the host computer.

2. Click the Automatic Bridging tab.

3. Check the box for **Automatically choose an available physical adapter**.

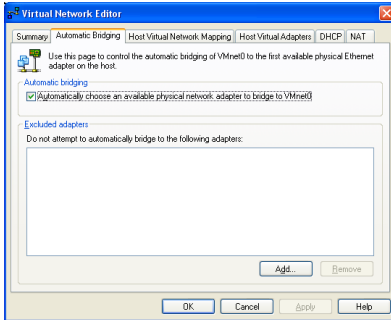

On host systems with more than one physical Ethernet adapter installed, the choice of which adapter Workstation uses is arbitrary. If you want to place restrictions on the choice, see the following section, [Excluding a Host Ethernet Adapter from VMnet0 Bridged Networking](#).

4. Click **OK** to save your changes and close the virtual network editor.

### Excluding a Host Ethernet Adapter from VMnet0 Bridged Networking

You can exclude a host Ethernet adapter from the list of adapters Workstation uses for automatic bridged networking on VMnet0. To exclude one or more physical Ethernet adapters:

1. Choose **Edit > Virtual Network Settings**.
2. Click the **Automatic Bridging** tab.
3. Click **Add** to put the physical adapter in the list of excluded devices.

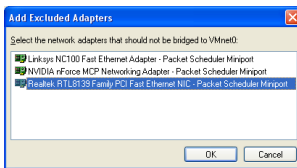

- In the Add Excluded Adapters dialog box, select the listing for the adapter you want to exclude, then click **OK**.

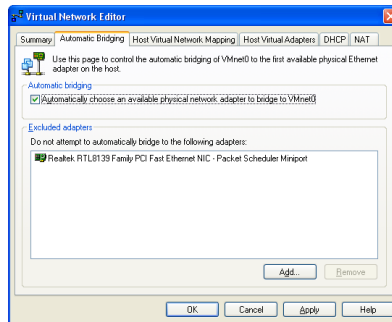

- Click **OK** to save your changes and close the virtual network editor.

### Removing a Host Ethernet Adapter from the Excluded Adapters List

To remove an adapter from the list of excluded adapters:

- Choose **Edit > Virtual Network Settings**.
- Click the **Automatic Bridging** tab.
- Select the name of the adapter you want to remove.
- Click **Remove**.
- Click **OK** to save your changes and close the virtual network editor.

### Choosing a Host Ethernet Adapter for Custom Bridged Networking

You can create a custom bridged network on virtual switches VMnet2 to VMnet7. To designate a physical Ethernet adapter to bridge to custom virtual switches

- Choose **Edit > Virtual Network Settings**.
- Click the **Host Virtual Network Mapping** tab.
- Choose an adapter from the drop-down list beside the name of the virtual switch you want to use.

**Caution:** Be careful when you change the bridged adapter mappings. If you reassign a physical Ethernet adapter to a different virtual network, any virtual machine using the original network loses its network connectivity via that network. You must then change the setting for each affected virtual machine's network adapter individually. This can be especially troublesome if your host has only one physical Ethernet adapter and you reassign it to a VMnet other than



VMnet0; even though the VMnet still appears to be bridged to an automatically chosen adapter, the only adapter it can use has been assigned to another VMnet.

4. Click **OK** to save your changes and close the virtual network editor.

## Changing Subnet or DHCP Settings for a Virtual Network

To make changes to the subnet or the DHCP settings for a virtual network

1. Click the button on the right that corresponds to the virtual network you want to configure.

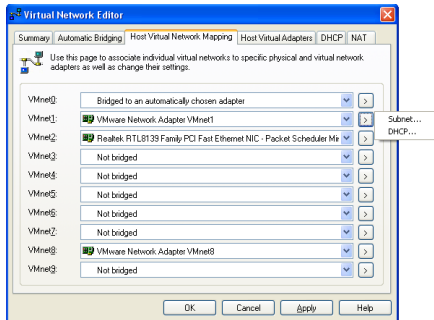

2. Choose **Subnet** or **DHCP**.
  - In the Subnet dialog box, you can change the subnet's IP address and the subnet mask

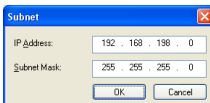

The address should specify a valid network address that is suitable for use with the subnet mask.

The default subnet mask is 255.255.255.0 (a class-C network). Typically, this means you should modify only the third number in the IP address — for example, x in 192.168.x.0 or 172.16.x.0. In general, you should not change the subnet mask. Certain virtual network services may not work as well with a customized subnet mask.

When you modify the network address or subnet mask, VMware Workstation automatically updates the IP address settings for other components — such as DHCP, NAT and host virtual adapter — on that virtual network to reflect the new settings. The specific settings that are automatically updated include DHCP lease range, DHCP server address, NAT gateway address and host virtual

adapter IP address. However, if you have changed any of these settings from its default value — even if you have later changed the setting back to the default — VMware Workstation does not update that setting automatically. Workstation presumes that custom settings are not to be modified.

- In the DHCP settings dialog box, you can change the range of IP addresses provided by the VMware Workstation DHCP server on a particular virtual network.

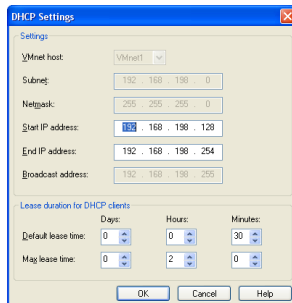

You can also use this dialog box to set the duration of DHCP leases provided to clients on the virtual network.

3. Click **OK** to save your changes and close the virtual network editor.

## Enabling, Disabling, Adding and Removing Host Virtual Adapters

When you install VMware Workstation, two network adapters are added to the configuration of your host operating system — one that allows the host to connect to the host-only network and one that allows the host to connect to the NAT network.

If you are not using a virtual network adapter, you may wish to remove it. On a Windows host, you can also choose to disable an adapter.

The presence of virtual network adapters has a slight performance cost, because broadcast packets must go to the extra adapters. On Windows networks, browsing your network may be slower than usual. And in some cases, these adapters interact with the host computer's networking configuration in undesirable ways.

### Disabling a Host Virtual Adapter on a Windows Host

Use the virtual network editor to disable any unwanted adapters.

1. Choose **Edit > Virtual Network Settings**
2. Click **Host Virtual Adapters**.

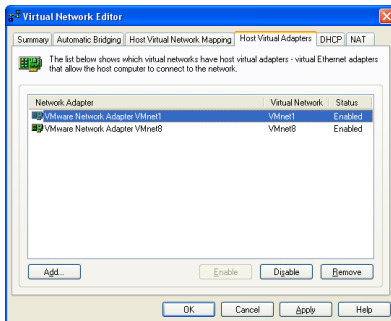

3. Select the adapter you want to disable.
4. Click **Disable**.
5. Click **OK**.

### Enabling a Disabled Host Virtual Adapter on a Windows Host

Follow these steps to enable a host virtual adapter on a Windows host.

1. Go to **Edit > Virtual Network Settings > Host Virtual Adapters**.
2. Select the disabled adapter you want to enable.
3. Click **Enable**.
4. Click **OK**.

### Adding a Host Virtual Adapter on a Windows Host

Follow these steps to add a host virtual adapter on a Windows host.

1. Go to **Edit > Virtual Network Settings > Host Virtual Adapters**.
2. Click **Add new adapter**.
3. Choose the virtual network on which you want to use the adapter and click **OK**.
4. Click **Apply** or **OK**.
  - Click **Apply** to enable the adapter without closing the window, allowing further configuration changes.
  - Click **OK** to close the virtual network editor.

### Removing a Host Virtual Adapter on a Windows Host

1. Go to **Edit > Virtual Network Settings > Host Virtual Adapters**.

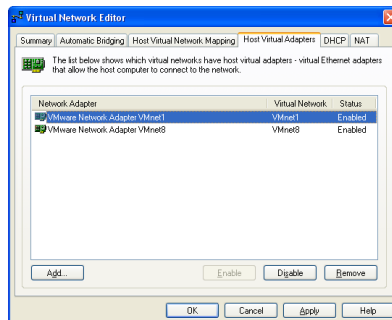

2. Select the adapter you want to remove, then click **Remove adapter**.
3. Click **OK**.

## Removing a Host Virtual Adapter on a Linux Host

1. Become root and run the VMware Workstation configuration program.

```
su -
vmware-config.pl
```

2. Watch for the following question

```
Do you want networking for your Virtual Machines? (yes/
no/help) [yes]
```

Answer Yes if you still want to use any networking in your virtual machines, then continue to the next question.

Otherwise, answer No to remove all networking.

3. If you answer Yes, the program prompts you to select the wizard or editor to edit your network configuration. Select editor. This is the only way to delete virtual network adapters without removing all of them.

```
Would you prefer to modify your existing networking
configuration using the wizard or the editor? (wizard/
editor/help) [wizard] editor
```

4. You see a list of virtual networks that have been configured. Select the network corresponding to the adapter you wish to disable.

```
The following virtual networks have been defined:
```

```
. vmnet0 is bridged to eth0
. vmnet1 is a host-only network on subnet 172.16.155.0.
. vmnet8 is NAT network on a private subnet 172.16.107.0.
```

```
Which virtual network do you wish to configure? (0-99) 1
```

5. You may be prompted to keep this virtual network. If you are sure you want to remove it, answer Yes to the question.

```
The network vmnet1 has been reserved for a host-only
network. You may change it, but it is highly recommended
that you use it as a host-only network. Are you sure you
want to modify it? (yes/no) [no] yes
```

6. When prompted about the type of virtual network, select None and the virtual network will be removed.

```
What type of virtual network do you wish to set vmnet1?
(bridged,hostonly,nat,none) [hostonly] none
```

## Advanced Networking Topics

The following sections describe advanced networking topics:

- [Selecting IP Addresses on a Host-only Network or NAT Configuration on page 327](#)
- [Avoiding IP Packet Leakage in a Host-Only Network on page 330](#)
- [Maintaining and Changing the MAC Address of a Virtual Machine on page 332](#)
- [Controlling Routing Information for a Host-only Network on a Linux Host on page 334](#)
- [Other Potential Issues with Host-Only Networking on a Linux Host on page 335](#)
- [Setting Up a Second Bridged Network Interface on a Linux Host on page 336](#)
- [Setting Up Two Separate Host-Only Networks on page 337](#)
- [Routing between Two Host-Only Networks on page 340](#)
- [Using Virtual Ethernet Adapters in Promiscuous Mode on a Linux Host on page 344](#)

## **Selecting IP Addresses on a Host-only Network or NAT Configuration**

A host-only network uses a private virtual network. The host and all virtual machines configured for host-only networking are connected to the network through a virtual switch. Typically, all the parties on this private network use the TCP/IP protocol suite, although other communication protocols may be used.

A network address translation (NAT) configuration also sets up a private network, which must be a TCP/IP network. The virtual machines configured for NAT are connected to that network through a virtual switch. The host computer is also connected to the private network used for NAT via a host virtual adapter.

Each virtual machine and the host must be assigned addresses on the private network. This is typically done using the DHCP server that comes with VMware Workstation. Note that this server does not service virtual (or physical) machines residing on bridged networks.

Addresses can also be assigned statically from a pool of addresses that are not assigned by the DHCP server.

When host-only networking is enabled at the time VMware Workstation is installed, the network number to use for the virtual network is automatically selected as an unused private IP network number. To find out what network is used on a Windows host, choose **Edit > Virtual Network Settings** and check the subnet number associated with the virtual network. On a Linux host, run `ifconfig` in a terminal.

A NAT configuration also uses an unused private network automatically selected when you install VMware Workstation. To find out what network is used on a Windows host, choose **Edit > Virtual Network Settings** and check the subnet number associated with the virtual network. On a Linux host, run `ifconfig` in a terminal.

Using DHCP to assign IP addresses is simpler and more automatic than statically assigning them. Most Windows operating systems, for example, come preconfigured to use DHCP at boot time, so Windows virtual machines can connect to the network the first time they are booted, without additional configuration. If you want your virtual machines to communicate with each other using names instead of IP addresses, however, you must set up a naming convention, a name server on the private network, or both. In that case it may be simpler to use static IP addresses.

In general, if you have virtual machines you intend to use frequently or for extended periods of time, it is probably most convenient to assign them static IP addresses or configure the VMware DHCP server to always assign the same IP address to each of these virtual machines.

## Configuring the DHCP Server on a Linux Host

On a Linux host, you configure the host-only DHCP server by editing the DHCP configuration file for VMnet1 (`/etc/vmware/vmnet1/dhcp/dhcp.conf`). To configure the DHCP server for the NAT network, edit the configuration file for VMnet8 (`/etc/vmware/vmnet8/dhcp/dhcp.conf`).

Editing the DHCP server configuration file requires information that is best obtained directly from the DHCP server documentation. Consult the manual pages `dhcpd` (8) and `dhcpd.conf` (8).

## Configuring the DHCP Server on a Windows Host

On a Windows host, use the virtual network editor to configure the DHCP server (**Edit > Virtual Network Settings > DHCP**).

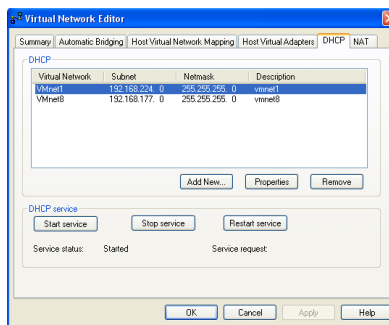

Select the virtual network for which you want to change settings and click **Properties**.

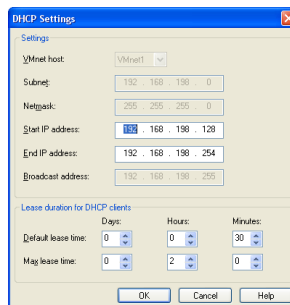

Make the desired changes, then click **OK**.



### Choosing the Method for Assigning IP Addresses

For virtual machines that you do not expect to keep for long, use DHCP and let it allocate an IP address.

For each host-only or NAT network, the available IP addresses are split up using the conventions shown in the tables below, where <net> is the network number assigned to your host-only or NAT network. VMware Workstation always uses a Class C address for host-only and NAT networks.

#### Address Use on a Host-Only Network

Range	Address use	Example
<net>.1	Host machine	192.168.0.1
<net>.2–<net>.127	Static addresses	192.168.0.2–192.168.0.127
<net>.128–<net>.253	DHCP-assigned	192.168.0.128–192.168.0.253
<net>.254	DHCP server	192.168.0.254
<net>.255	Broadcasting	192.168.0.255

#### Address Use on a NAT Network

Range	Address use	Example
<net>.1	Host machine	192.168.0.1
<net>.2	NAT device	192.168.0.2
<net>.3–<net>.127	Static addresses	192.168.0.3–192.168.0.127
<net>.128–<net>.253	DHCP-assigned	192.168.0.128–192.168.0.253
<net>.254	DHCP server	192.168.0.254
<net>.255	Broadcasting	192.168.0.255

## Avoiding IP Packet Leakage in a Host-Only Network

By design, each host-only network should be confined to the host machine on which it is set up. That is, no packets sent by virtual machines on this network should leak out to a physical network attached to the host. Packet leakage can occur only if a machine actively forwards packets. It is possible for the host machine or any virtual machine running on the host-only network to be configured in a way that permits packet leakage.

### Windows Hosts

Systems using server versions of Windows 2000 are capable of forwarding IP packets that are not addressed to them. By default, however, these systems come with IP packet forwarding disabled. IP forwarding is not an issue on Windows 2000 Professional, Windows XP Professional or Windows XP Home Edition hosts.

If you find packets leaking out of a host-only network on a Windows 2000 host computer, check to see if forwarding has been enabled on the host machine. If it is enabled, disable it.

On a Windows 2000 or Windows Server 2003 host, go to **Start > Programs > Administrative Tools > Routing and Remote Access**. An icon on the left is labeled with the host name. If a green dot appears over the icon, IP forwarding is turned on. To turn it off, right-click the icon and disable **Routing and Remote Access**. A red dot appears, indicating that IP forwarding is disabled.

**Windows 2000 Professional Users:** The Windows 2000 Administration Tools are not installed on a Windows 2000 Professional system. However, you can install these tools from a Windows 2000 Server or Windows 2000 Advanced Server CD-ROM.

To install Windows 2000 Administration Tools on a local computer:

1. Open the i386 folder on the applicable Windows 2000 Server disc.
2. Double-click the `adminpak.msi` file. Follow the instructions that appear in the Windows 2000 Administration Tools Setup wizard.
3. After Windows 2000 Administration Tools are installed, you can access most of the server administrative tools by choosing **Start > Programs > Administrative Tools**.

### **Linux Hosts**

If you find packets leaking out of a host-only network on a Linux host computer, check to see if forwarding has mistakenly been enabled on the host machine. If it is enabled, disable it.

For many Linux systems, disable forwarding by writing a 0 (zero) to the special file `/proc/sys/net/ipv4/ip_forward`. As root, enter this command:

```
echo 0 > /proc/sys/net/ipv4/ip_forward
```

Other Linux systems have a system configuration option that you can set. The method depends on your Linux distribution. You may use a control panel, specify a setting at the time you compile your kernel, or possibly enter a specification when you boot your system. Consult your operating system documentation for details on the method to use with your particular distribution.

### **Using Filtering**

If the host computer has multiple network adapters, it may be intentionally configured to do IP forwarding. If that is the case, you do not want to disable forwarding. In that case, to avoid packet leakage you must enable a packet filtering facility and specify that packets from the host-only network should not be sent outside the host computer. Consult your operating system documentation for details on how to configure packet filtering.

### **Leaks from a Virtual Machine**

Virtual machines may leak packets, as well. For example, if you use Dial-Up Networking support in a virtual machine and packet forwarding is enabled, host-only network traffic may leak out through the dial-up connection.

To prevent the leakage, be sure packet forwarding is disabled in your guest operating system.

## Maintaining and Changing the MAC Address of a Virtual Machine

When a virtual machine is powered on, VMware Workstation automatically assigns each of its virtual network adapters an Ethernet MAC address. MAC stands for media access control. A MAC address is the unique address assigned to each Ethernet network device.

The software guarantees that virtual machines are assigned unique MAC addresses within a given host system. In most cases, the virtual machine is assigned the same MAC address every time it is powered on, so long as the virtual machine is not moved (the path and filename for the virtual machine's configuration file must remain the same) and no changes are made to certain settings in the configuration file.

In addition, VMware Workstation does its best, but cannot guarantee, to automatically assign unique MAC addresses for virtual machines running on multiple host systems.

### Avoiding MAC Changes

To avoid changes in the MAC address automatically assigned to a virtual machine, you must not move the virtual machine's configuration file. Moving it to a different host computer or even moving it to a different location on the same host computer changes the MAC address.

You also need to be sure not to change certain settings in the virtual machine's configuration files. If you never edit the configuration file by hand and do not remove the virtual Ethernet adapter, these settings remain untouched. If you do edit the configuration file by hand, be sure not to remove or change the following options:

```
ethernet [n] .generatedAddress
ethernet [n] .addressType
ethernet [n] .generatedAddressOffset
uuid.location
uuid.bios
ethernet [n] .present
```

In these options, [n] is the number of the virtual Ethernet adapter, for example ethernet0.

**Note:** To preserve a virtual Ethernet adapter's MAC address, you also must be careful not to remove the adapter. If you remove the adapter, then recreate it, the adapter may receive a different MAC address.

## Manually Assigning a MAC Address

If you want to guarantee that the same MAC address is assigned to a given virtual machine every time, even if the virtual machine is moved, or if you want to guarantee a unique MAC address for each virtual machine within a networked environment, you can assign the address manually instead of allowing VMware Workstation to assign it automatically.

To assign the same, unique MAC address to any virtual machine manually, use a text editor to remove three lines from the configuration file and add one line. The configuration file has a `.vmx` extension at the end of the filename. On a Linux host, a virtual machine created with an earlier VMware product may have a configuration file with a `.cfg` extension.

Remove the three lines that begin with the following from the configuration file:

```
ethernet [n] .generatedAddress
ethernet [n] .addressType
ethernet [n] .generatedAddressOffset
```

In these options, `[n]` is the number of the virtual Ethernet adapter — for example `ethernet0`.

Add the following line to the configuration file:

```
ethernet [n] .address = 00:50:56:XX:YY:ZZ
```

In this line, `XX` must be a valid hexadecimal number between `00h` and `3Fh`, and `YY` and `ZZ` must be valid hexadecimal numbers between `00h` and `FFh`. Because VMware Workstation virtual machines do not support arbitrary MAC addresses, you must use the above format.

So long as you choose a value for `XX:YY:ZZ` that is unique among your hard-coded addresses (where `XX` is a valid hexadecimal number between `00h` and `3Fh`, and `YY` and `ZZ` are valid hexadecimal numbers between `00h` and `FFh`), conflicts between the automatically assigned MAC addresses and the manually assigned addresses should never occur.

## Controlling Routing Information for a Host-only Network on a Linux Host

A host-only network is a full-fledged network. It has a network interface associated with it (VMnet1) that is marked "up" at the time the host operating system is booted. Consequently, routing server processes that operate on the host operating system, such as `routed` and `gated`, automatically discover it and propagate information on how to reach it unless you explicitly configure them not to do so.

If either of these programs is being run only to receive routing information, the easiest solution is to run it with a `-q` option so that it does not supply routing information, only receives it.

If, however, they are running because they are to supply routing information, then you need to configure them so they do not advertise routes to the host-only network.

Unfortunately, the version of `routed` that comes with many distributions of Linux has no support for specifying that an interface should not be advertised. Consult the `routed(8)` manual page for your system in case you have a more contemporary version of the software.

For `gated`, configuration is involved. You need to explicitly exclude the VMnet1 interface from any protocol activity. If you need to run virtual machines on a host-only network on a multihomed system where `gated` is used and have problems doing so, please contact VMware technical support by submitting a support request at [www.vmware.com/requestsupport](http://www.vmware.com/requestsupport).

## Other Potential Issues with Host-Only Networking on a Linux Host

The following are common issues you may encounter when you are configuring a host-only network.

### DHCPD on the Linux Host Does Not Work after VMware Workstation Installation

If you were running the DHCP server program `dhcpd` on your machine before installing VMware Workstation, it probably was configured to respond to DHCP requests from clients on any network interface present on the machine. When host-only networking is configured, an additional network interface, `VMnet1`, is marked “up” and available for use, and `dhcpd` may notice this.

In such cases, some `dhcpd` implementations abort if their configuration files do not include a subnet specification for the interface — even if `dhcpd` is not supposed to respond to messages that arrive through the interface.

The best solution to this problem is to add a line in the following format to the `dhcpd` configuration file:

```
subnet <net>.0 netmask 255.255.255.0 {}
```

`<net>` is the network number assigned to your host-only network — for example, 192.168.0. This line in the configuration file informs `dhcpd` about the host-only network and tells it explicitly not to respond to any DHCP requests it sees coming from it.

An alternative solution is to explicitly state the set of network interfaces that you want `dhcpd` to listen to each time you start the program. For example, if your machine has one Ethernet interface, `eth0`, then each time you start `dhcpd`, list it on the command line:

```
dhcpd eth0
```

This keeps `dhcpd` from probing for all available network interfaces.

If the above solutions do not work for your DHCP server program, then it likely is old. You can try upgrading to a more current version such as the DHCP software available from the ISC ([www.isc.org](http://www.isc.org)).

### DHCP and Dynamic Domain Name Service (DDNS)

DHCP can be used to hand out IP addresses as well as other information, such as the identity of a host running a name server and the nearest router or gateway. The DHCP server in VMware Workstation 5 does not provide a means to dynamically establish a relationship between the IP address it assigns and a client's name (that is, to update a DNS server using DDNS).

If you want to use names to communicate with other virtual machines you must either edit the DHCP configuration file for VMnet1 (`/etc/vmware/vmnet1.conf`) or use IP addresses that are statically bound to a host name. Editing the DHCP server configuration file requires information that is best obtained directly from the DHCP server documentation. Consult the manual pages `dhcpd(8)` and `dhcpd.conf(8)`.

### Setting Up a Second Bridged Network Interface on a Linux Host

If you have two Ethernet adapters installed on your host computer, connected to two different networks, you may want your virtual machines on that host computer to bridge to both Ethernet adapters so the virtual machines can access either or both physical networks.

When you install VMware Workstation on a host computer with multiple Ethernet adapters, you have the option of configuring more than one bridged network. You can also configure additional bridged networks at any time by rerunning `vmware-config.pl`.

1. On the host computer, become root (`su -`) and run the VMware Workstation configuration program.

```
vmware-config.pl
```

2. If you have more than one physical Ethernet adapter, one of the prompts you see is similar to this:

```
The following bridged networks have been defined:
. vmnet0 is bridged to eth0
Do you wish to configure another bridged network? (yes/no) [no]
Enter yes.
```

3. If you have additional physical Ethernet adapters not yet connected to a bridged network, the prompt is repeated, showing information about all currently configured bridged networks.
4. When you have set up all the bridged networks you want, enter `no`.



## **Setting Up Two Separate Host-Only Networks**

For some configurations, you may need to set up more than one host-only network on the same host computer.

You may, for example, want to have two virtual machines connected to one host-only network, and at the same time have other virtual machines connected to another host-only network so the network traffic on each network is isolated.

Or you may want to test routing between two virtual networks. Or test a virtual machine with multiple network interface cards — without using any physical Ethernet adapters.

On Windows hosts, the first host-only network is set up automatically when you install VMware Workstation.

On Linux hosts, the first host-only network is set up when you run the `vmware-config.pl` program after you install VMware Workstation, provided you agree to install host-only networking. If you did not agree to use host-only networking, you need to run the program again to set up host-only networking.

To set up the second host-only network, follow the steps outlined below for your host operating system.

### **Setting Up the Second Host-Only Interface on a Windows Host**

Follow these steps to set up the second host-only interface on a Windows host.

1. Go to **Edit > Virtual Network Settings > Host Virtual Adapters**.
2. Click **Add new adapter**.
3. Choose the virtual network on which you want to use the adapter and click **OK**.
4. Click **Apply**.
5. Click **OK** to close the virtual network editor.

## Setting Up the Second Host-Only Interface on a Linux Host

- As root (`su -`), run the VMware Workstation configuration program.  

```
/usr/bin/vmware-config.pl
```
- Use the wizard to modify your configuration. After asking about a NAT network, the program asks:  

```
Do you want to be able to use host-only networking in your virtual machines?
```

Answer Yes.

The wizard reports on host-only networks that you have already set up on the host or, if none is present, configures the first host-only network.
- The wizard asks:  

```
Do you wish to configure another host-only network?
```

Answer Yes.

Repeat this step until you have as many host-only networks as you want. Then answer No.
- Complete the remaining steps in the wizard. When it is finished, it restarts all services used by VMware Workstation.
- Run `ifconfig`. You should see at least four network interfaces — `eth0`, `lo`, `vmnet1` and `vmnet2`. If the VMnet interfaces do not show up immediately, wait for a minute, then run the command again. These four interfaces should have different IP address on separate subnets.

## Configuring the Virtual Machines

Now you have two host-only interfaces (VMnet1 and VMnet2). You are ready to set up your virtual machines for one of the following configurations:

- The virtual machine is configured with one virtual Ethernet adapter, and that virtual adapter is connected to the default host-only interface (VMnet 1).
- The virtual machine is configured with one virtual Ethernet adapter, and that virtual adapter is connected to the newly created host-only interface (VMnet2).
- The virtual machine is configured with two virtual Ethernet adapters. One virtual adapter is connected to the default host-only interface (VMnet1) and the other virtual adapter is connected to the newly created host-only interface (VMnet2).

**Configuration 1 – Connect to the Default Host-Only Interface**

1. Create the virtual machine using the New Virtual Machine Wizard or use an existing virtual machine.
2. Launch VMware Workstation and open the virtual machine.
3. Edit the configuration using the virtual machine settings editor (**VM > Settings**).  
Select **Network Adapter**, then choose **Host-only (VMnet1)** from the drop-down list on the right.  
If no network adapter is shown in the list of devices, click **Add**, then use the Add Hardware Wizard to add an adapter.

**Configuration 2 – Connect to the Newly Created Host-Only Interface**

1. Create the virtual machine using the New Virtual Machine Wizard or use an existing virtual machine.
2. Launch VMware Workstation and open the virtual machine.
3. Edit the configuration using the virtual machine settings editor (**VM > Settings**).  
Select **Network Adapter**, then choose **Custom (VMnet2)** from the drop-down list on the right.  
If no network adapter is shown in the list of devices, click **Add**, then use the Add Hardware Wizard to add an adapter.

**Configuration 3 – Connect to Two Host-Only Interfaces**

1. Create the virtual machine using the New Virtual Machine Wizard or use an existing virtual machine.
2. Launch VMware Workstation and open the virtual machine.
3. Edit the configuration using the virtual machine settings editor (**VM > Settings**).  
Select the first network adapter in the list of devices, then choose **Host-only (VMnet1)** from the drop-down list on the right. Select the second network adapter in the list of devices, then choose **Custom (VMnet2)** from the drop-down list on the right.  
If you need to add one or more network adapters, click **Add**, then use the Add Hardware Wizard to add an adapter.

At this point you can power on the virtual machine and install your guest operating system. In configurations 1 and 2 you see one AMD PCNet Family Adapter. In configuration 3 you see two AMD PCNet Family Adapters within the guest. Configure the Ethernet adapters as you would physical adapters on a physical computer, giving each an IP address on the appropriate VMnet subnet.

On Windows hosts, you can open a command prompt and run `ipconfig /all` to see what IP addresses each host-only network is using.

On Linux hosts, you can open a terminal and run `ifconfig` to see what IP addresses each host-only network is using.

## Routing between Two Host-Only Networks

If you are setting up a complex test network using virtual machines, you may want to have two independent host-only networks with a router between them.

There are two basic approaches. In one, the router software runs on the host computer. In the other, the router software runs in its own virtual machine. In both cases, you need two host-only interfaces.

The examples described here outline the simplest case, with one virtual machine on each of the host-only networks. For more complex configurations, you can add more virtual machines and host-only networks as appropriate.

### Setting Up the First Host-Only Interface

On Windows hosts, the first host-only network is set up automatically when you install VMware Workstation.

On Linux hosts, the first host-only network was set up when you ran the `vmware-config.pl` program after you installed VMware Workstation, provided you agreed to install host-only networking. If you did not agree to use host-only networking, you need to run the program again to set up host-only networking.

### Setting Up the Second Host-Only Interface — Windows Host

Follow these steps to set up the second host-only interface on a Windows host.

1. Go to **Edit > Virtual Network Settings > Host Virtual Adapters**.
2. Click **Add new adapter**.
3. Choose the virtual network on which you want to use the adapter and click **OK**.
4. Click **Apply**.
5. Click **OK** to close the virtual network editor.

### Setting Up the Second Host-Only Interface — Linux Host

1. As root (`su -`), run the VMware Workstation configuration program.  

```
/usr/bin/vmware-config.pl
```
2. Use the wizard to modify your configuration. After asking about a NAT network, the program asks:  

```
Do you want to be able to use host-only networking in your virtual machines?
```

 Answer Yes.  
 The wizard reports on host-only networks that you have already set up on the host or, if none is present, configures the first host-only network.
3. The wizard asks:  

```
Do you wish to configure another host-only network?
```

 Answer Yes.  
 Repeat this step until you have as many host-only networks as you want. Then answer No.
4. Complete the wizard. When it is finished, it restarts all services used by VMware Workstation.
5. Run `ifconfig`. You should see at least four network interfaces — `eth0`, `lo`, `vmnet1` and `vmnet2`. If the VMnet interfaces do not show up immediately, wait for a minute, then run the command again. These four interfaces should have different IP address on separate subnets.

### Setting Up the Virtual Machines

Now you have two host-only network adapters on the host computer. Each is connected to its own virtual switch (VMnet1 and VMnet2). You are ready to create and configure your virtual machines and connect them to the appropriate virtual switches.

#### Virtual Machine 1 – Connected to the Default Host-only Interface

1. Create the virtual machine using the New Virtual Machine Wizard or use an existing virtual machine.
2. Launch VMware Workstation and open the virtual machine.
3. Edit the configuration using the virtual machine settings editor (**VM > Settings**). Select **Network Adapter** and choose **Host-only (VMnet1)** from the drop-down list on the right.  
 If no network adapter is shown in the list of devices, click **Add**, then use the Add Hardware Wizard to add an adapter.

### Virtual Machine 2 – Connected to the Newly Created Host-Only Interface

1. Create the virtual machine using the New Virtual Machine Wizard or use an existing virtual machine.
2. Launch VMware Workstation and open the virtual machine.
3. Edit the configuration using the virtual machine settings editor (**VM > Settings**).  
Select **Network Adapter** and choose **Custom (VMnet2)** from the drop-down list on the right. If no network adapter is shown in the list of devices, click **Add**, then use the Add Hardware Wizard to add an adapter.

If you plan to run the router software on your host computer, you can skip the next section.

### Virtual Machine 3 – Connected to Both Host-Only Interfaces

If you plan to run the router software on a virtual machine, set up a third virtual machine for that purpose.

1. Create the virtual machine using the New Virtual Machine Wizard or use an existing virtual machine.
2. Launch VMware Workstation and open the virtual machine.
3. Edit the configuration using the virtual machine settings editor (**VM > Settings**).  
Select the first network adapter in the list of devices and choose **Host-only (VMnet1)** from the drop-down list on the right. Select the second network adapter in the list of devices, then select **Custom (VMnet2)** from the drop-down list on the right.

If you need to add one or more network adapters, click **Add**, then use the Add Hardware Wizard to add an adapter.

Now you need to configure the networking components on the host and in the virtual machines. The recommended approach uses static IP addresses for all the virtual machines.

1. Stop the VMnet DHCP server service.  
**Windows host:** Choose **Edit > Virtual Network Settings > DHCP** and click **Stop service**.  
**Linux host:** Stop the `vmnet-dhcpd` service.  

```
killall -TERM vmnet-dhcpd
```
2. Install guest operating systems in each of the virtual machines.
3. Install the router software — on the host computer or in the third virtual machine, depending on the approach you are using.

4. Configure networking in the first two virtual machines to use addresses on the appropriate host-only network.

On Windows hosts, you can open a command prompt and run `ipconfig /all` to see what IP addresses each host-only network is using.

On Linux hosts, you can open a terminal and run `ifconfig` to see what IP addresses each host-only network is using.

5. If you are running the router on the host computer, assign default router addresses based on the addresses of the host-only adapters on the host computer. In the first virtual machine's networking configuration, the default router address should be the IP address for the host-only adapter connected to VMnet1. In the second virtual machine's networking configuration, the default router address should be the IP address for the host-only adapter connected to VMnet2.

If you are running the router software in the third virtual machine, set the default router addresses in the first two virtual machines based on those used by the third virtual machine. In the first virtual machine's networking configuration, the default router address should be the IP address for the third virtual machine's Ethernet adapter connected to VMnet1. In the second virtual machine's networking configuration, the default router address should be the IP address for the third virtual machine's Ethernet adapter connected to VMnet2.

At this point you should be able to ping the router machine from virtual machines one and two. And if the router software is set up correctly, you should be able to communicate between the first and second virtual machines.

## Using Virtual Ethernet Adapters in Promiscuous Mode on a Linux Host

VMware Workstation does not allow the virtual Ethernet adapter to go into promiscuous mode unless the user running VMware Workstation has permission to make that setting. This follows the standard Linux practice that only root can put a network interface into promiscuous mode.

When you install and configure VMware Workstation, you must run the installation as root. VMware Workstation creates the VMnet devices with root ownership and root group ownership, which means that only root has read and write permissions to the devices.

To set the virtual machine's Ethernet adapter to promiscuous mode, you must launch VMware Workstation as root because you must have read and write access to the VMnet device. For example, if you are using bridged networking, you must have access to `/dev/vmnet0`.

To grant selected other users read and write access to the VMnet device, you can create a new group, add the appropriate users to the group and grant that group read and write access to the appropriate device. You must make these changes on the host operating system as root (`su -`). For example, you can enter the following commands:

```
chgrp <newgroup> /dev/vmnet0
chmod g+rw /dev/vmnet0
```

`<newgroup>` is the group that should have the ability to set `vmnet0` to promiscuous mode.

If you want all users to be able to set the virtual Ethernet adapter (`/dev/vmnet0` in our example) to promiscuous mode, run the following command on the host operating system as root:

```
chmod a+rw /dev/vmnet0
```



# Understanding NAT

Network address translation — or NAT — provides a simple way for virtual machines to use most client applications over almost any type of network connection available to the host. The only requirement is that the network connection must support TCP/IP.

NAT is useful when you have a limited supply of IP addresses or are connected to the network through a non-Ethernet network adapter. NAT works by translating addresses of virtual machines in a private VMnet network to that of the host machine. When a virtual machine sends a request to access a network resource, it appears to the network resource as if the request came from the host machine.

NAT uses the host's own network resources to connect to the external network. Thus, any TCP/IP network resource to which the host has access should be available through the NAT connection.

The chief advantage of NAT is that it provides a transparent, easy to configure way for virtual machines to gain access to network resources.

This section discusses the following topics:

- [Using NAT on page 346](#)
- [The Host Computer and the NAT Network on page 346](#)
- [DHCP on the NAT Network on page 346](#)
- [DNS on the NAT Network on page 347](#)
- [External Access from the NAT Network on page 347](#)
- [Advanced NAT Configuration on page 348](#)
- [Custom NAT and DHCP Configuration on a Windows Host on page 352](#)
- [Considerations for Using NAT on page 353](#)
- [Using NAT with NetLogon on page 353](#)
- [Sample Linux vmnetnat.conf File on page 355](#)

## Using NAT

The NAT device is connected to the VMnet8 virtual switch. Virtual machines connected to the NAT network also use the VMnet8 virtual switch.

The NAT device waits for packets coming from virtual machines on the VMnet8 virtual network. When a packet arrives, the NAT device translates the address of the virtual machine to that of the host before forwarding the packet to the external network. When data arrives from the external network for the virtual machine on the private network, the NAT device receives the data, replaces the network address with that of the virtual machine and forwards the data to the virtual machine on the virtual network. This translation occurs automatically and requires minimal configuration on the guest and the host.

## The Host Computer and the NAT Network

The host computer has a host virtual adapter on the NAT network (identical to the host virtual adapter on the host-only network). This adapter allows the host and the virtual machines to communicate with each other for such purposes as file sharing. The NAT device never forwards traffic from the host virtual adapter.

## DHCP on the NAT Network

In order to make networking configuration easy, a DHCP server is automatically installed when you install VMware Workstation. Virtual machines running on the network with the NAT device can dynamically obtain their IP addresses by sending out DHCP requests. The DHCP server on the NAT network, which is also used in host-only networking configurations, dynamically allocates IP addresses in the range of <net>.128 through <net>.254, where <net> is the network number assigned to your NAT network. VMware Workstation always uses a Class C address for NAT networks. IP addresses <net>.3 through <net>.127 can be used for static IP addresses. IP address <net>.1 is reserved for the host adapter; <net>.2 is reserved for the NAT device.

In addition to the IP address, the DHCP server on the NAT network also sends out additional configuration information that enables the virtual machine to operate automatically. This information includes the default gateway and the DNS server. In the DHCP response, the NAT device instructs the virtual machine to use the IP address <net>.2 as the default gateway and DNS server. This causes all IP packets destined for the external network and DNS requests to be forwarded to the NAT device.

## **DNS on the NAT Network**

The NAT device acts as a DNS server for the virtual machines on the NAT network. Actually, the NAT device is a DNS proxy and merely forwards DNS requests from the virtual machines to a DNS server that is known by the host. Responses come back to the NAT device, which then forwards them to the virtual machines.

If they get their configuration information from DHCP, the virtual machines on the NAT network automatically use the NAT device as the DNS server. However, the virtual machines can be statically configured to use another DNS server.

The virtual machines in the private NAT network are not, themselves, accessible via DNS. If you want the virtual machines running on the NAT network to access each other by DNS names, you must set up a private DNS server connected to the NAT network.

## **External Access from the NAT Network**

In general, any protocol using TCP or UDP can be used automatically by a virtual machine on the NAT network so long as the virtual machine initiates the network connection. This is true for most client applications such as Web browsing, Telnet, passive-mode FTP and downloading streaming video. Additional protocol support has been built into the NAT device to allow FTP and ICMP echo (ping) to work completely transparently through the NAT.

On the external network to which the host is connected, any virtual machine on the NAT network appears to be the host itself, because its network traffic uses the host's IP address. It is able to send and receive data using TCP/IP to any machine that is accessible from the host.

Before any such communication can occur, the NAT device must set up a mapping between the virtual machine's address on the private NAT network and the host's network address on the external network.

When a virtual machine initiates a network connection with another network resource, this mapping is created automatically. The operation is perfectly transparent to the user of the virtual machine on the NAT network. No additional work needs to be done to let the virtual machine access the external network.

The same cannot be said for network connections that are initiated from the external network to a virtual machine on the NAT network.

When a machine on the external network attempts to initiate a connection with a virtual machine on the NAT network, it cannot reach the virtual machine because the NAT device does not forward the request. Network connections that are initiated from outside the NAT network are not transparent.

However, it is possible to configure port forwarding manually on the NAT device so network traffic destined for a certain port can still be forwarded automatically to a virtual machine on the NAT network. For details, see [Advanced NAT Configuration](#) below.

File sharing of the type used by Windows operating systems and Samba is possible among computers on the NAT network — including virtual machines and the host computer. If you are using WINS servers on your network, a virtual machine using NAT networking can access shared files and folders on the host that are known by the WINS server so long as those shared files and folders are in the same workgroup or domain.

## Advanced NAT Configuration

### Windows Host

Configure the NAT device using the virtual network editor (**Edit > Virtual Network Settings > NAT**).

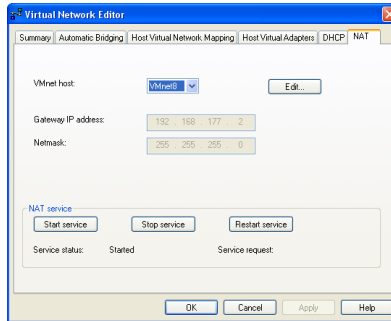

You can stop and start the virtual NAT device by clicking the appropriate buttons.

To edit NAT settings for a virtual network, choose it from the drop-down menu, then click **Edit**.

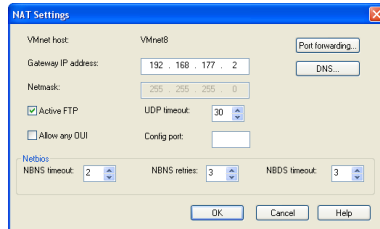

Change any NAT settings you wish. Click the appropriate button to set up or change port forwarding or to specify DNS servers the virtual NAT device should use.

### **Linux Host**

Use the NAT configuration file on the host to configure the NAT device. This file is `/etc/vmware/vmnet8/nat/nat.conf`.

The configuration file is divided into sections. Each section configures a part of the NAT device. Text surrounded by square brackets — such as `[host]` — marks the beginning of a section. In each section is a configuration parameter that can be set. The configuration parameters take the form `ip = 192.168.27.1/24`.

For an example of a NAT configuration file, see [Sample Linux vmnetnat.conf File on page 355](#). The configuration file variables are described below.

### **The [host] Section**

#### **ip**

The IP address that the NAT device should use. It can optionally be followed by a slash and the number of bits in the subnet.

#### **netmask**

The subnet mask to use for the NAT network. DHCP addresses are allocated from this range of addresses.

#### **configport**

A port that can be used to access status information about the NAT device.

#### **device**

The VMnet device to use. Windows devices are of the form `VMnet <x>` where `<x>` is the number of the VMnet. Linux devices are of the form `/dev/vmnet <x>`.

**activeFTP**

Flag to indicate if active FTP is to be allowed. Active FTP allows incoming connections to be opened by the remote FTP server. Turning this off means that only passive mode FTP works. Set to 0 to turn it off.

**The [udp] Section****timeout**

Number of minutes to keep the UDP mapping for the NAT network.

**The [dns] Section**

This section is for Windows hosts only. Linux does not use this section.

**policy**

Policy to use for DNS forwarding. Accepted values include `order`, `rotate`, and `burst`.

- `order` — send one DNS request at a time in order of the name servers
- `rotate` — send one DNS request at a time and rotate through the DNS servers
- `burst` — send to three servers and wait for the first one to respond

**timeout**

Time in seconds before retrying a DNS request.

**retries**

Number of retries before the NAT device gives up on a DNS request.

**autodetect**

Flag to indicate if the NAT device should automatically detect the DNS servers available to the host.

**nameserver1**

IP address of a DNS server to use.

**nameserver2**

IP address of a DNS server to use.

**nameserver3**

IP address of a DNS server to use.

If autodetect is on and some name servers are specified, the DNS servers specified in `nameserver1`, `nameserver2` and `nameserver3` are added before the list of detected DNS servers.

**The [netbios] Section**

This section applies to Windows hosts only. Linux does not use this section.

```
nbnsTimeout = 2
```

Timeout for NBNS queries.

```
nbnsRetries = 3
```

Number of retries for each NBNS query.

```
nbdstTimeout = 3
```

Timeout for NBDS queries.

**The [incomingtcp] Section**

This section is used to configure TCP port forwarding for NAT. In this section, you can assign a port number to an IP address and port number on a virtual machine.

The following line shows the format used in this section.

```
8887 = 192.168.27.128:21
```

This example creates a mapping from port 8887 on the host to the IP address 192.168.27.128 and port 21. When this mapping is set and an external machine connects to the host at port 8887, the network packets are automatically forwarded to port 21 (the standard port for FTP) on the virtual machine with IP address 192.168.27.128.

**The [incomingudp] Section**

This section is used to configure UDP port forwarding for NAT. In this section, you can assign a port number to an IP address and port number on a virtual machine.

The following line shows the format used in this section. It illustrates a way to forward X server traffic from the host port 6000 to the virtual machine's port 6001.

```
6000 = 192.168.27.128:6001
```

This example creates a mapping from port 6000 on the host to the IP address 192.168.27.128 and port 6001. When this mapping is set and an external machine connects to the host at port 6000, the network packets are automatically forwarded to port 6001 on the virtual machine with IP address 192.168.27.128.

## Custom NAT and DHCP Configuration on a Windows Host

If you are an advanced user on a Windows host computer, you may wish to make custom configuration settings by editing the NAT and DHCP configuration files. If your host operating system is installed on the C drive, the configuration files for NAT and DHCP are in the following locations:

- **NAT:** `C:\Documents and Settings\All Users\Application Data\VMware\vmnetnat.conf`
- **DHCP:** `C:\Documents and Settings\All Users\Application Data\VMware\vmnetdhcp.conf`

**Note:** In VMware Workstation 5, you can change many key NAT and DHCP settings using the virtual network editor (**Edit > Virtual Network Settings**). However, if you have made manual changes to the configuration files, some or all of those changes may be lost when you use the virtual network editor. If you have made manual changes, you should make backup copies of the files before changing any settings in the virtual network editor. After making changes in the virtual network editor, you can copy your manual changes back into the appropriate configuration files.

### Specifying Connections from Ports below 1024

When a client machine makes a TCP or UDP connection to a server, the connection comes from a particular port on the client (the source port) and connects to a particular port on the server (the destination port). For security reasons, some servers accept connections only from source ports below 1024. You may see this configuration on machines used as NFS file servers, for example.

If a virtual machine using NAT attempts to connect to a server that requires the client to use a source port below 1024, it is important that the NAT device forward the request from a port below 1024. You can specify this behavior in the `vmnetnat.conf` file.

This behavior is controlled by entries in sections headed `[privilegedUDP]` and `[privilegedTCP]`. You may need to add settings to or modify settings in either or both of these sections, depending on the kind of connection you need to make.

You can set two parameters, each of which appears on a separate line.

```
autodetect = <n>
```

The `autodetect` setting determines whether the VMware NAT device automatically attempts to map virtual machine source ports below 1024 to NAT source ports below 1024. A setting of `1` means true. A setting of `0` means false. On a Windows host, the default is `1` (true). On a Linux host, the default is `0` (false).



```
port = <n>
```

The port setting specifies a destination port (where <n> is the port on the server that accepts the connection from the client). Whenever a virtual machine connects to the specified port on any server, the NAT device attempts to make the connection from a source port below 1024. You may include one or more port settings in the [privilegedUDP] or [privilegedTCP] section or in both sections, as required for the connections you need to make. Enter each port setting on a separate line.

## **Considerations for Using NAT**

Because NAT requires that every packet sent and received from virtual machines is in the NAT network, there is an unavoidable performance penalty. Our experiments show that the penalty is minor for dial-up and DSL connections and performance is adequate for most VMware Workstation uses.

NAT is not perfectly transparent. It does not normally allow connections to be initiated from outside the network, although you can set up server connections by manually configuring the NAT device. The practical result is that some TCP and UDP protocols that require a connection be initiated from the server machine — some peer to peer applications, for example — do not work automatically, and some may not work at all.

A standard NAT configuration provides basic-level firewall protection because the NAT device can initiate connections from the private NAT network, but devices on the external network cannot normally initiate connections to the private NAT network.

## **Using NAT with NetLogon**

When using NAT networking in a virtual machine with a Windows guest operating system running on a Windows host, you can use NetLogon to log on to a Windows domain from the virtual machine. You can then access file shares known by the WINS server in the domain.

To use NetLogon, you need to know how WINS servers and Windows domain controllers work. This section explains how to set up the virtual machine to use NetLogon. The setup process is similar to the way you set up a physical computer on one LAN that is using a domain controller on another LAN.

In order to log on to a Windows domain outside the virtual NAT network, the virtual machine needs access to a WINS server for that domain. There are two ways you can connect the virtual machine to a WINS server. You can connect to the WINS server provided by the DHCP server used on the NAT network, provided that the WINS server is already set up on the host. If you want to connect from the virtual machine to a

WINS server not set up on the host, you can manually enter the IP address of the WINS server.

### **Using NAT to Connect to an Existing WINS Server Already Set Up on the Host**

In order to use this method, a WINS server in the same workgroup or domain must be set up on the host. These steps use Windows 2000, Windows XP or Windows Server 2003 as a guide. The process is similar for Windows NT, Windows Me and Windows 9x guests.

1. In the virtual machine, right-click on **My Network Places** and choose **Properties**.
2. In the Network Connections window, right-click the virtual network adapter and choose **Properties**.
3. In the Properties dialog box, select **Internet Protocol (TCP/IP)**, then click **Properties**.
4. In the TCP/IP Properties dialog box, click **Advanced**.
5. Click the **WINS** tab, then under **NetBIOS setting**, select **Use NetBIOS setting from DHCP Server**.
6. Click **OK** twice, then click **Close**.

### **Manually Entering the IP Address of a WINS Server**

Use this method to connect to a WINS server in the same workgroup or domain that is not already set up on the host.

1. In the virtual machine, right-click on **My Network Places** and choose **Properties**.
2. In the Network Connections window, right-click the virtual network adapter and choose **Properties**.
3. In the Properties dialog box, select **Internet Protocol (TCP/IP)**, then click **Properties**.
4. In the TCP/IP Properties dialog box, click **Advanced**.
5. Click the **WINS** tab, then click **Add**.
6. In the TCP/IP WINS Server dialog box, enter the IP address for the WINS server in the **WINS server** field, then click **OK**. The IP address of the WINS server appears in the **WINS addresses** list on the **WINS** tab.  
  
Repeat steps 5 and 6 for each WINS server to which you want to connect from this virtual machine.
7. Click **OK** twice, then click **Close**.

Now that the virtual machine has an IP address for a WINS server, you use NetLogon in the virtual machine to log on to a domain and access shares in that domain.

For example, if the WINS server covers a domain with a domain controller it is possible to access that domain controller from the virtual machine and add the virtual machine to the domain. You need to know the user ID and password of the Administrator on the domain controller.

**Note:** Your access is limited to shares of virtual machines that are on the same NAT network or are bridged on the same domain.

## Sample Linux `vmnetnat.conf` File

```
# Linux NAT configuration file

[host]

# NAT gateway address
ip = 192.168.237.2/24
hostMAC = 00:50:56:C0:00:08

# enable configuration; disabled by default for security reasons
#configport = 33445

# VMnet device if not specified on command line
device = VMnet8

# Allow PORT/EPRT FTP commands (they need incoming TCP stream...)
activeFTP = 1

# Allows the source to have any OUI. Turn this one if you change the OUI
# in the MAC address of your virtual machines.
#allowAnyOUI = 1

[udp]
# Timeout in seconds, 0 = no timeout, default = 60; real value might
# be up to 100% longer
timeout = 30

[dns]
# This section applies only to Windows.
#
# Policy to use for DNS forwarding. Accepted values include order,
# rotate, burst.
#
# order: send one DNS request at a time in order of the name servers
# rotate: send one DNS request at a time, rotate through the DNS servers
```

```
# burst: send to three servers and wait for the first one to respond
policy = order;

# Timeout in seconds before retrying DNS request.
timeout = 2

# Retries before giving up on DNS request
retries = 3

# Automatically detect the DNS servers (not supported in Windows NT)
autodetect = 1

# List of DNS servers to use. Up to three may be specified
#nameserver1 = 208.23.14.2
#nameserver2 = 63.93.12.3
#nameserver3 = 208.23.14.4

[netbios]
# This section applies only to Windows.

# Timeout for NBNS queries.
nbnsTimeout = 2

# Number of retries for each NBNS query.
nbnsRetries = 3

# Timeout for NBDS queries.
nbdsTimeout = 3

[incomingtcp]
# Use these with care - anyone can enter into your virtual machine through
# these...

# FTP (both active and passive FTP is always enabled)
# ftp localhost 8887
#8887 = 192.168.27.128:21

# WEB (make sure that if you are using named webhosting, names point to
# your host, not to guest... And if you are forwarding port other
# than 80 make sure that your server copes with mismatched port
# number in Host: header)
# lynx http://localhost:8888
#8888 = 192.168.27.128:80

# SSH
# ssh -p 8889 root@localhost
#8889 = 192.168.27.128:22
```

```
[incomingudp]  
# UDP port forwarding example  
#6000 = 192.168.27.128:6001
```

## Using Samba with Workstation

If you have Samba running on your Linux host, there are several things you can do to configure Samba so that it works with Workstation, as described in this section.

### Modifying Your Samba Configuration

Be sure to modify your Samba configuration so it includes the IP subnet used by the VMware Workstation virtual Ethernet adapter, VMnet1.

To determine what subnet is being used by VMnet1, run

```
/sbin/ifconfig vmnet1
```

Make sure the Samba password file includes entries for all users of the virtual machine who will access the host's file system. The user names and passwords in the Samba password file must match those used for logging on to the guest operating system.

You may add user names and passwords to the Samba password file at any time from a terminal window on your Linux host computer.

1. Log on to the root account.  
`su`
2. Run the Samba password command.  
`smbpasswd -a <username>`  
`<username>` is the user name to add. Follow the instructions on the screen.
3. Log out of the root account.  
`exit`

### Using a Samba Server for Both Bridged and Host-Only Networks

To use your Samba server for both host-only and bridged networking, you must modify one parameter in the `smb.conf` file. You can define the `interface` parameter so your Samba server serves multiple interfaces. An example of this is:

```
interface = eth0 vmnet1
```

This example tells the Samba server to listen to and use both the `eth0` and `vmnet1` interfaces — the interfaces used by bridged and host-only networking, respectively.

### Using Samba without Network Access

To make Samba inaccessible from your physical Ethernet interface, add this line:

```
interfaces = vmnet*
```

to `/etc/samba/smb.conf` and restart Samba.

# Configuring Video and Sound

---

The following sections provide information on configuring the video display and sound for VMware Workstation.

- [Setting Screen Color Depth on page 360](#)
  - [Changing Screen Color Depth on the Host on page 360](#)
  - [Changing Screen Color Depth in the Virtual Machine on page 361](#)
- [Using Full Screen Mode on a Linux Host on page 362](#)
- [Experimental Support for Direct3D on page 363](#)
- [Configuring Sound on page 369](#)
  - [Installing Sound Drivers in Windows 9x and Windows NT Guest Operating Systems on page 369](#)

## Setting Screen Color Depth

The number of screen colors available in the guest operating system depends on the screen color setting of the host operating system.

Virtual machines support

- 16-color (VGA) mode
- 8-bit pseudocolor
- 16 bits per pixel (16 significant bits per pixel)
- 32 bits per pixel (24 significant bits per pixel)

If the host is in 15-bit color mode, the guest operating system's color setting controls offer 15-bit mode in place of 16-bit mode.

If the host is in 24-bit color mode, the guest operating system's color setting controls offer 24-bit mode in place of 32-bit mode.

If you run a guest operating system set for a greater number of colors than your host operating system is using, you can encounter various problems. In some cases, for example, the colors in the guest are not correct. In others, the guest operating system is not able to use a graphical interface.

In such a case, you can either increase the number of colors available on the host or decrease the number of colors used in the guest.

For best performance, use the same number of colors in the guest and on the host.

### Changing Screen Color Depth on the Host

If you choose to change the color settings on your host operating system, you should first shut down all guest operating systems, power off the virtual machines and close VMware Workstation.

Follow standard procedures for changing the color settings on your host operating system, then restart VMware Workstation and the virtual machines.



## **Changing Screen Color Depth in the Virtual Machine**

If you choose to change the color settings in the guest operating system, the approach you take depends on the guest operating system.

Follow the normal process for changing screen colors in your guest operating system. In a Windows guest, the Display Properties control panel offers only those settings that are supported.

In a Linux or FreeBSD guest, you must change the color depth before you start the X server or restart the X server after making the changes.

## Using Full Screen Mode on a Linux Host

When you switch to full screen mode, VMware Workstation changes the full screen display resolution to better match the resolution set in the guest operating system. On a Linux host, VMware Workstation uses the VidMode or DGA2 extension from the XFree86 Project or XiG's Xfs to match the host resolution to the one requested by the guest running in the virtual machine.

In a few cases, VMware Workstation may not find the best resolution.

When VMware Workstation switches to full screen mode, it can choose only those resolutions that are already configured for the host's X server. If a virtual machine runs at a resolution that does not match a mode listed in host's X server configuration, then VMware Workstation chooses the closest larger mode (and uses black borders) for full screen mode or else simply does not offer full screen mode at all.

It is possible to have bad modes configured for the X server on your host. If your host's X configuration was automatically generated, or if you never tested all modes with your current monitor and video card, it is possible that some enabled modes do not work with your monitor. However, the mode-switching code in VMware Workstation has no way of knowing this and a virtual machine that tries to use a resolution with a bad mode line can cause your display to fail to display correctly.

If this happens, immediately leave full screen mode by pressing Ctrl-Alt, then fix your X server configuration and restart X. However, if the only problem is that the image is off center or is not quite the right size on the monitor, you can usually correct it using the controls on your monitor. Note that most modern monitors are capable of storing separate settings for each resolution, so changing the settings for a new mode should not affect the settings for the host resolution.

## Experimental Support for Direct3D

VMware Workstation includes experimental support for Direct3D video acceleration. This feature is not fully functional.

**Caution:** Features with experimental support are not intended to be enabled on production systems. Enabling 3-D acceleration may cause the host or guest to crash, causing you to lose data, even if 3-D applications are not active.

Experimental support for Direct3D acceleration is described in the following sections:

- [Audience for Direct3D Experimental Support on page 363](#)
- [Accelerated 3-D Limitations on page 364](#)
- [Enabling Accelerated 3-D on page 364](#)
- [Known Issues on page 367](#)
- [Helping VMware with Experimental Support on page 368](#)

### **Audience for Direct3D Experimental Support**

Workstation provides this feature for advanced customers who want to explore an in-progress implementation of 3-D acceleration.

Technical support for accelerated 3-D is not yet provided for Workstation. However, we encourage you to file a Support Request so we can evaluate problems you might experience with accelerated 3-D. Please review [Helping VMware with Experimental Support on page 368](#) before you file a support request.

## Accelerated 3-D Limitations

Experimental support for Direct3D applies only to Windows 2000 and Windows XP guests, on hosts running Windows 2000, Windows XP, or Linux.

Experimental support has the following limitations:

- Workstation accelerates DirectX 8 applications, and DirectX 9 applications that use only the subset of DirectX 8.
- Support for 3-D applications is not optimized for performance.
- OpenGL applications run in software emulation mode.

Not all aspects of 3-D acceleration are enabled. The following 3-D features are not accelerated:

- Pixel and vertex shaders
- Multiple vertex streams
- Hardware bump-mapping, environment mapping
- Projected textures
- Textures with one, three, or four dimensions

## Enabling Accelerated 3-D

**Caution:** Features with experimental support are not intended for production systems.

By default, Direct3D technology is disabled. You must prepare the host first, the virtual machine second, and the guest operating system last.

### **Enabling Accelerated 3-D for a Host**

To enable a host for accelerated 3-D:

**Hardware** — Use a host video card with support for accelerated OpenGL, such as NVIDIA TNT, GeForce and Quadro cards, or ATI FireGL and Radeon 8500 (or higher) video cards. If you are unsure, check with your hardware manufacturer.

**Software** — Upgrade the video drivers for your host to the latest available.

- NVIDIA drivers are available at [www.nvidia.com/content/drivers/drivers.asp](http://www.nvidia.com/content/drivers/drivers.asp)
- ATI drivers are available at [www.ati.com/support/driver.html](http://www.ati.com/support/driver.html)
- (Linux only) — NVIDIA GPUs support the features used in Direct3D acceleration. Linux open source drivers are not enabled. However, if you have a video card with an Radeon 8500 (or better) GPU, you can attempt to use the Direct3D acceleration using the ATI driver available at [www.ati.com/support/drivers/linux/radeon-linux.html](http://www.ati.com/support/drivers/linux/radeon-linux.html)

**Windows** — Perform these steps to prepare a Windows 2000 or Windows XP host.

Make sure hardware acceleration is turned up in the display properties.

1. Right-click the desktop and choose **Properties > Settings > Advanced > Troubleshoot**.
2. Move the **Hardware Acceleration** slider all the way to the **Full** position.

**Linux** — Perform these steps to test your Linux host for compatibility:

1. To verify that direct rendering is enabled, run  
`glxinfo | grep direct`
2. To ensure that 3-D applications work on your host, run  
`glxgears`

After your host is configured, configure a virtual machine for accelerated 3-D.

## Enabling Accelerated 3-D for a Virtual Machine

To enable a virtual machine for accelerated 3-D

1. Choose a virtual machine with Windows 2000 or XP guest operating system.

**Note:** Do not enable Direct3D on a virtual machine that is powered on or suspended.

2. Add the following to the configuration (.vmx) file for the virtual machine:

```
mks.enable3d = TRUE
```

This line enables accelerated 3-D on the host. It is required to support accelerated 3-D in the guest and also enables the host to accelerate 2-D portions of the guest display.

3. You may also add one or both of the following optional lines:

```
svga.vramSize = 67108864
```

This line increases the amount of VRAM on the virtual display card to 64 MB. Adding more VRAM helps to reduce thrashing in the guest. The maximum value is 128 MB.

```
vmmouse.present = FALSE
```

This line disables the absolute pointing device in the guest. Applications which require DirectInput relative mode need to turn off the absolute pointing device in the guest. In practice, this is only required for a certain class of full screen 3-D applications (for example, real-time games like first-person shooters).

**Note:** If you set the `vmmouse.present` option, you should also turn off the preference for motion ungrabbing in the **Input** tab of the Preferences settings dialog.

To turn off ungrabbing for `vmouse.present`:

- a. Choose **Edit > Preferences**.
- b. Click **Input**.
- c. Deselect **Ungrab when cursor leaves window**.

## Enabling Accelerated 3-D for a Guest Operating System

To enable the guest operating system for accelerated 3-D

1. Power on the virtual machine.
2. Install VMware Tools.

**Note:** It is critical for stability that you install the version of VMware Tools that matches the version of VMware Workstation you are running.

3. Install DirectX 9.0c End User Runtime

This download is available from Microsoft at

[www.microsoft.com/downloads/search.aspx?displaylang=en&categoryid=2](http://www.microsoft.com/downloads/search.aspx?displaylang=en&categoryid=2)

4. Install and run your 3-D applications.

## Known Issues

Common problems for Direct3-D experimental support include the following:

- Switching tabs in the VMware Workstation console does not work while 3-D applications are running.
- Switching between full screen and windowed mode does not work while 3-D applications are running.
- Running multiple 3-D applications simultaneously may crash the Workstation application.
- When a 3-D application is running, you cannot suspend or resume the virtual machine, and you cannot take snapshots.
- Graphical corruption occurs, such as:
  - Screenshot or movie capture displays graphical corruption for the 3-D area of the screen.
  - The guest cursor occasionally has a halo of corruption (usually white) when mousing over 3-D regions in the guest operating system.

## Helping VMware with Experimental Support

VMware offers only experimental support for Direct3D acceleration. VMware may not respond personally to all support requests regarding Direct3D acceleration.

VMware is interested in

- Catastrophic failures such as bluescreening the guest, or 3-D applications that crash VMware Workstation
- Testing reports about ATI 8500 (and later) video cards (whether or not they work)
- Testing reports about Linux host operating systems (whether or not they work).
- Testing reports about specific DirectX8 and DX9 applications you are using (whether or not they work)
- Specific problems you are having when running 3-D
- Specific directions you want to see VMware 3-D technology evolve

Specific and detailed reports can help speed this feature from experimental support to full functionality. Please include as many details about your configuration, 3-D applications, and hardware as you can.



## **Configuring Sound**

VMware Workstation provides a sound device compatible with the Sound Blaster AudioPCI and supports sound in Windows 95, Windows 98, Windows Me, Windows NT, Windows 2000, Windows XP, Windows Server 2003 and Linux guest operating systems. The VMware Workstation sound device is enabled by default.

Sound support includes PCM (pulse code modulation) output and input. For example, you can play `.wav` files, MP3 audio and Real Media audio. MIDI output from Windows guests is supported through the Windows software synthesizer. MIDI input is not supported, and no MIDI support is available for Linux guests.

Windows 2000, Windows XP and most recent Linux distributions automatically detect the sound device and install appropriate drivers for it.

### **Installing Sound Drivers in Windows 9x and Windows NT Guest Operating Systems**

Windows 95, Windows 98, Windows 98SE and Windows NT 4.0 do not have drivers for the Sound Blaster AudioPCI adapter. To use sound in these guest operating systems, you must download the driver from the Creative Labs Web site ([www.creative.com](http://www.creative.com)) and install it in the guest operating system.

Creative Labs has a number of Web sites serving various regions of the world. The adapter name varies, depending on the region, but usually includes PCI 128.



# Connecting Devices

---

The following sections describe how to use various devices with a virtual machine:

- [Using Parallel Ports on page 372](#)
- [Using Serial Ports on page 377](#)
- [Keyboard Mapping on a Linux Host on page 389](#)
- [Using USB Devices in a Virtual Machine on page 397](#)
- [Connecting to a Generic SCSI Device on page 402](#)

## Using Parallel Ports

VMware Workstation supports a partial emulation of bidirectional PS/2-style ports.

On Linux hosts, VMware Workstation requires that the parallel port “PC-style hardware” option (CONFIG\_PARPORT\_PC) be built and loaded as a kernel module (that is, it must be set to “m”). VMware Workstation is unable to use parallel port devices if CONFIG\_PARPORT\_PC is built directly (compiled) into the kernel. This limitation exists because CONFIG\_PARPORT\_PC does not correctly export its symbols.

### Parallel Ports

Parallel ports are used by a variety of devices, including printers, scanners, dongles and disk drives.

Currently, VMware Workstation provides only partial emulation of PS/2 hardware. Specifically, interrupts requested by a device connected to the physical port are not passed to the virtual machine. Also, the guest operating system cannot use DMA (direct memory access) to move data to or from the port. For this reason, not all devices that attach to the parallel port are guaranteed to work correctly.

### Installation in Guest Operating Systems

If the virtual machine is configured with a parallel port, most guest operating systems automatically detect it at installation time and install the required drivers. Some operating systems, including Linux, Windows NT and Windows 2000, automatically detect the ports at boot time. Others, like Windows 95 and Windows 98, do not.

To add a parallel port to the virtual machine's configuration, take these steps with the virtual machine powered off.

1. Open the virtual machine settings editor.

#### VM > Settings

2. Click **Add** to start the New Hardware Wizard.
3. Select **Parallel Port**, then click **Next**.
4. Make the appropriate selection to use a physical parallel port or connect the virtual parallel port to a file.
5. If you selected **Use physical port**, choose the port from the drop-down list.  
If you selected **Use output file**, enter the path and filename or browse to the location of the file.  
Under **Device status**, the default setting is **Connect at power on**. Clear the check box if you want to deselect this setting.

6. Click **Finish**.

In a Windows 95 or Windows 98 guest, after you add the port, run the guest operating system's Add New Hardware Wizard (**Start > Settings > Control Panel > Add New Hardware**) and let Windows detect the new device.

## Configuring a Parallel Port on a Linux Host

For the parallel port to work properly in a guest, it must first be configured properly on the host. Most issues involving parallel port functionality are a result of the host configuration. Check these areas of concern: the version of your Linux kernel, your device access permissions and the required modules.

- [Parallel Ports and Linux 2.2.x Kernels on page 373](#)
- [Parallel Ports and Linux 2.4.x Kernels on page 374](#)
- [Parallel Ports and Linux 2.6.x Kernels on page 375](#)
- [Device Permissions on page 376](#)

### Parallel Ports and Linux 2.2.x Kernels

The 2.2.x kernels that support parallel ports use the `parport`, `parport_pc` and `vmpuser` modules. Be sure that PC Style Hardware (`CONFIG_PARPORT_PC`) is loaded as a module, as mentioned at the beginning of [Using Parallel Ports on page 372](#). The `vmpuser` module is supplied by VMware Workstation to give virtual machines user-level access to the parallel port.

To see if these modules are installed and running on your system, run the `lsmod` command as the root user. These three modules should be included in the listing of running modules. You can also look at the `/proc/modules` file for the same list.

To load the proper modules, run this command:

```
insmod -k <modulename>
```

If none of the listed parallel port modules is running, use this command:

```
insmod -k parport_pc
```

This command inserts the three modules needed for a parallel port.

If you continue to see problems, it is possible that the `lp` module is running. If it is, the virtual machine cannot use the parallel port correctly. To remove the `lp` module, run this command as the root user:

```
rmmmod lp
```

You should also ensure that the line referring to the `lp` module in the `/etc/modules.conf` or `/etc/conf.modules` file is removed or commented out by inserting a hash character (`#`) at the beginning of the line. The name of the configuration file depends on the Linux distribution you are using. When you reboot

the host after removing this line, the configuration file no longer starts the `lp` module.

To ensure that the proper modules for the parallel port are loaded at boot time, add this line to the `/etc/modules.conf` or `/etc/conf.modules` file:

```
alias parport_lowlevel parport_pc
```

### Parallel Ports and Linux 2.4.x Kernels

Be sure that PC Style Hardware (`CONFIG_PARPORT_PC`) is loaded as a module as mentioned at the beginning of [Using Parallel Ports on page 372](#). If you are using a 2.4.x kernel, the modules that provide parallel port functionality are `parport`, `parport_pc` and `ppdev`.

To see if these modules are installed and running on your system, run the `lsmod` command as the root user. These three modules should be included in the listing of running modules. You can also look at the `/proc/modules` file for the same list.

To load the proper modules, run this command:

```
insmod -k <modulename>
```

If none of the listed parallel port modules is running, use this command:

```
insmod -k parport_pc
```

This command inserts the three modules needed for a parallel port.

If you continue to see problems, it is possible that the `lp` module is running. If it is, the virtual machine cannot use the parallel port correctly. To remove the `lp` module, run this command as the root user:

```
rmmod lp
```

You should also ensure that the line referring to the `lp` module in the `/etc/modules.conf` or `/etc/conf.modules` file is removed or commented out by inserting a hash character (`#`) at the beginning of the line. The name of the configuration file depends on the Linux distribution you are using. When you reboot the host after removing this line, the configuration file no longer starts the `lp` module.

To ensure that the proper modules for the parallel port are loaded at boot time, add this line to the `/etc/modules.conf` or `/etc/conf.modules` file:

```
alias parport_lowlevel parport_pc
```

Linux kernels in the 2.4.x series also use a special arbitrator that allows access to the parallel port hardware. If the parallel port is in use by the host, the guest cannot use it. If a virtual machine is using the parallel port, the host and any users accessing the host are not given access to the device. VMware Workstation puts a lock on the device, and this lock restricts access so only the virtual machine can use the port.

You can choose **VM > Removable Devices** to disconnect the parallel port from the virtual machine and reconnect it.

### Parallel Ports and Linux 2.6.x Kernels

Be sure that PC Style Hardware (CONFIG\_PARPORT\_PC) is loaded as a module as mentioned at the beginning of [Using Parallel Ports on page 372](#). If you are using a 2.6.x kernel, the modules that provide parallel port functionality are `modprobe <modulename>` and `modprobe parport_pc`.

To see if these modules are installed and running on your system, run the `lsmod` command as the root user. You can also look at the `/proc/modules` file for the same list.

With 2.6.x, loading `parport_pc` does not load all three modules. If none of the listed parallel port modules is running, use this command:

```
modprobe parport_pc && modprobe ppdev
```

This command inserts the three modules needed for a parallel port.

If you continue to see problems, it is possible that the `lp` module is running. If it is, the virtual machine cannot use the parallel port correctly. To remove the `lp` module, run this command as the root user:

```
rmmod lp
```

You should also ensure that the line referring to the `lp` module in the `/etc/modules.conf` or `/etc/conf.modules` file is removed or commented out by inserting a hash character (`#`) at the beginning of the line. The name of the configuration file depends on the Linux distribution you are using. When you reboot the host after removing this line, the configuration file no longer starts the `lp` module.

To ensure that the proper modules for the parallel port are loaded at boot time, add this line to the `/etc/modules.conf` or `/etc/conf.modules` file:

```
alias parport_lowlevel parport_pc
```

Linux kernels in the 2.6.x series also use a special arbitrator that allows access to the parallel port hardware. If the parallel port is in use by the host, the guest cannot use it. If a virtual machine is using the parallel port, the host and any users accessing the host are not given access to the device. VMware Workstation puts a lock on the device, and this lock restricts access so only the virtual machine can use the port.

You can choose **VM > Removable Devices** to disconnect the parallel port from the virtual machine and reconnect it.

## Device Permissions

Some Linux distributions by default do not grant the virtual machine access to the `lp` and `parport` devices. In most of these cases, the owner of the device is `root` and the associated group is `lp`. To allow the VMware user to access the device, add the user to the associated group. To view the owner and group of the device, run this command:

```
ls -la /dev/parport0
```

The third and fourth columns of the output show the owner and group, respectively.

To add the user to the device group, edit the `/etc/group` file. On the line starting with `lp`, which defines the `lp` group, add the VMware Workstation user's user name. You must make this change as the root user. The following line provides an example for a user whose user name is `userj`.

```
lp: :7:daemon,lp,userj
```

The next time the user logs on to the host, the changes take effect.

## Special Notes for the Iomega Zip Drive

On Windows 95 or Windows 98, use of older drivers for the Iomega Zip drive may cause the guest operating system to lock up intermittently at boot time or during installation of the guest operating system. The newest Iomega drivers work reliably in our tests. They are available at [www.iomega.com/software/index.html](http://www.iomega.com/software/index.html).



## Using Serial Ports

A VMware Workstation virtual machine can use up to four virtual serial ports. The virtual serial ports can be configured in several ways.

- You can connect a virtual serial port to a physical serial port on the host computer.
- You can connect a virtual serial port to a file on the host computer.
- You can make a direct connection between two virtual machines or between a virtual machine and an application running on the host computer.

You can also select whether to connect the virtual serial port when you power on the virtual machine.

### Using a Serial Port on the Host Computer

You can set up the virtual serial port in a virtual machine to use a physical serial port on the host computer. This is useful, for example, if you want to use an external modem or a hand-held device in your virtual machine.

To install a virtual serial port that connects to a physical serial port on the host computer, take the following steps:

1. Open the virtual machine settings editor (**VM > Settings**).
2. Click **Add** to start the Add Hardware Wizard.
3. Select **Serial Port**, then click **Next**.

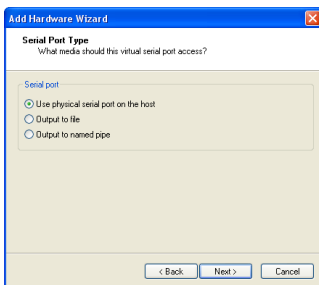

4. Select **Use physical serial port on the host**, then click **Next**.

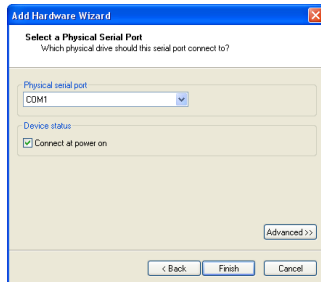

5. Choose the port on the host computer that you want to use for this serial connection. By default, the device status setting is **Connect at power on**. You may deselect this setting if you wish.

Click **Advanced** if you want to configure this serial port to use polled mode. This option is of interest primarily to developers who are using debugging tools that communicate over a serial connection. For more information, see [Special Configuration Options for Advanced Users on page 385](#).

6. Click **Finish**, then click **OK** to close the virtual machine settings editor.
7. Power on the virtual machine.

## Using a File on the Host Computer

You can set up the virtual serial port in a virtual machine to send its output to a file on the host computer. This is useful, for example, if you want to capture the data a program running in the virtual machine sends to the virtual serial port or if you need a quick way to transfer a file from the guest to the host.

To install a virtual serial port that connects to a file on the host computer, take the following steps:

1. Open the virtual machine settings editor (**VM > Settings**).
2. Click **Add** to start the Add Hardware Wizard.

3. Select **Serial Port**, then click **Next**.

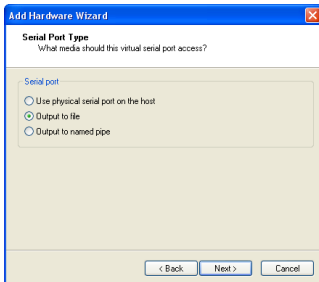

4. Select **Output to file**, then click **Next**.

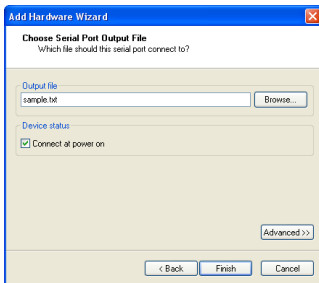

5. Browse to the file on the host computer that you want to use to store the output of the virtual serial port. By default, the device status setting is **Connect at power on**. You may deselect this setting if you wish.

Click **Advanced** if you want to configure this serial port to use polled mode. This option is of interest primarily to developers who are using debugging tools that communicate over a serial connection. For more information, see [Special Configuration Options for Advanced Users on page 385](#).

6. Click **Finish**, then click **OK** to close the virtual machine settings editor.
7. Power on the virtual machine.

## Connecting an Application on the Host to a Virtual Machine

You can set up the virtual serial port in a virtual machine to connect to an application on the host computer. This is useful, for example, if you want to use an application on the host to capture debugging information sent from the virtual machine's serial port.

To install a direct serial connection between an application on the host and a virtual machine, take the following steps:

### Windows Host

1. Open the virtual machine settings editor (**VM > Settings**).
2. Click **Add** to start the Add Hardware Wizard.
3. Select **Serial Port**, then click **Next**.

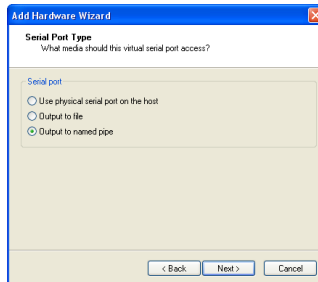

4. Select **Output to named pipe**, then click **Next**.

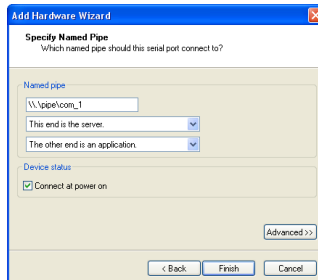

5. Use the default pipe name, or enter another pipe name of your choice. The pipe name must follow the form `\\.\pipe\<namedpipe>` — that is, it must begin with `\\.\pipe\`.
6. Select **This end is the server** or **This end is the client**. In general, select **This end is the server** if you plan to start this end of the connection first.
7. Select **The other end is an application**.

8. By default, the device status setting is **Connect at power on**. You may deselect this setting if you wish.

Click **Advanced** if you want to configure this serial port to use polled mode. This option is of interest primarily to developers who are using debugging tools that communicate over a serial connection. For more information, see [Special Configuration Options for Advanced Users on page 385](#).

9. Click **Finish**, then click **OK** to close the virtual machine settings editor.
10. On your host computer, configure the application that communicates with the virtual machine to use the same pipe name.
11. Power on the virtual machine.

### Linux Host

1. Open the virtual machine settings editor (**VM > Settings**).
2. Click **Add** to start the Add Hardware Wizard.
3. Select **Serial Port**, then click **Next**.
4. Select **Output to named pipe**, then click **Next**.
5. In the **Path** field, enter `/tmp/<socket>` or another Unix socket name of your choice.
6. Select **This end is the server** or **This end is the client**. In general, select **This end is the server** if you plan to start this end of the connection first.
7. Select **The other end is an application**.
8. By default, the device status setting is **Connect at power on**. You may deselect this setting if you wish.  
  
Click **Advanced** if you want to configure this serial port to use polled mode. This option is of interest primarily to developers who are using debugging tools that communicate over a serial connection. For more information, see [Special Configuration Options for Advanced Users on page 385](#).
9. Click **Finish**.
10. Click **OK** to save your configuration and close the virtual machine settings editor.
11. On your host computer, configure the application that communicates with the virtual machine to use the same Unix socket name.
12. Power on the virtual machine.

## Connecting Two Virtual Machines

You can set up the virtual serial ports in two virtual machines to connect to each other. This is useful, for example, if you want to use an application in one virtual machine to capture debugging information sent from the other virtual machine's serial port.

To install a direct serial connection between two virtual machines (a server and a client), take the following steps:

### Windows Host

#### In the server virtual machine

1. Open the virtual machine settings editor (VM > Settings).
2. Click **Add** to start the Add Hardware Wizard.
3. Select **Serial Port**, then click **Next**.

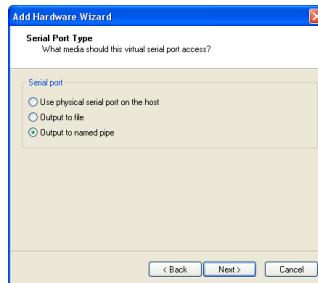

4. Select **Output to named pipe**, then click **Next**.

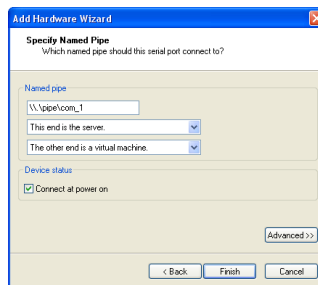

5. Use the default pipe name, or enter another pipe name of your choice. The pipe name must follow the form `\\.\pipe\<namedpipe>` — that is, it must begin with `\\.\pipe\`.
6. Select **This end is the server**.

7. Select **The other end is a virtual machine**.
8. By default, the device status setting is **Connect at power on**. You may deselect this setting if you wish.

Click **Advanced** if you want to configure this serial port to use polled mode. This option is of interest primarily to developers who are using debugging tools that communicate over a serial connection. For more information, see [Special Configuration Options for Advanced Users on page 385](#).

9. Click **Finish**, then click **OK** to close the virtual machine settings editor.

### In the client virtual machine

1. Open the virtual machine settings editor (**VM > Settings**).
2. Click **Add** to start the Add Hardware Wizard.
3. Select **Serial Port**, then click **Next**.

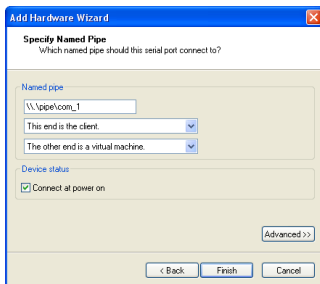

4. Select **Use named pipe**.
5. Use the default name, or enter another pipe name of your choice. The pipe name must follow the form `\\.\pipe\<namedpipe>` — that is, it must begin with `\\.\pipe\`. The pipe name must be the same on both server and client.
6. Select **This end is the client**.
7. Select **The other end is a virtual machine**.
8. By default, the device status setting is **Connect at power on**. You may deselect this setting if you wish.

Click **Advanced** if you want to configure this serial port to use polled mode. This option is of interest primarily to developers who are using debugging tools that communicate over a serial connection. For more information, see [Special Configuration Options for Advanced Users on page 385](#).

9. Click **Finish**, then click **OK** to close the virtual machine settings editor.

## Linux Host

### In the server virtual machine

1. Open the virtual machine settings editor (**VM > Settings**).
2. Click **Add** to start the Add Hardware Wizard.
3. Select **Serial Port**, then click **Next**.
4. Select **Output to named pipe**, then click **Next**.
5. In the **Path** field, enter `/tmp/<socket>` or another Unix socket name of your choice.
6. Select **This end is the server**.
7. Select **The other end is a virtual machine**.
8. By default, the device status setting is **Connect at power on**. You may deselect this setting if you wish.

Click **Advanced** if you want to configure this serial port to use polled mode. This option is of interest primarily to developers who are using debugging tools that communicate over a serial connection. For more information, see [Special Configuration Options for Advanced Users on page 385](#).

9. Click **Finish**, then click **OK** to save your configuration and close the virtual machine settings editor.

### In the client virtual machine

1. Open the virtual machine settings editor (**VM > Settings**).
2. Click **Add** to start the Add Hardware Wizard.
3. Select **Serial Port**, then click **Next**.
4. Select **Output to named pipe**, then click **Next**.
5. In the **Path** field, enter `/tmp/<socket>` or another Unix socket name of your choice. The pipe name must be the same on both server and client.
6. Select **This end is the client**.
7. Select **The other end is a virtual machine**.



- By default, the device status setting is **Connect at power on**. You may deselect this setting if you wish.

Click **Advanced** if you want to configure this serial port to use polled mode. This option is of interest primarily to developers who are using debugging tools that communicate over a serial connection. For more information, see [Special Configuration Options for Advanced Users on page 385](#).

- Click **Finish**, then click **OK** to save your configuration and close the virtual machine settings editor.

## Special Configuration Options for Advanced Users

Two special configuration options are available for serial connections between a virtual machine and the host or between two virtual machines. These options are of interest primarily to developers who are using debugging tools that communicate over a serial connection.

### Improving CPU Performance when Debugging

The first option must be set in the virtual machine settings editor. This option is useful when the serial port is being used by the guest operating system in polled mode as opposed to interrupt mode. Polled mode causes the virtual machine to consume a disproportionate share of CPU time. This makes the host and other guests run sluggishly.

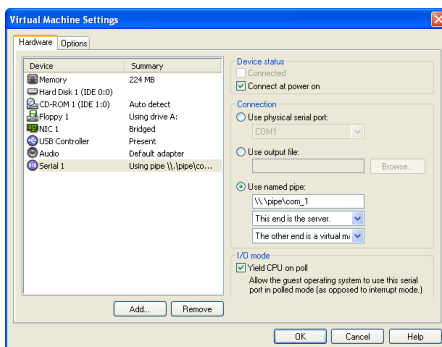

To restore performance for applications on the host, in the virtual machine settings editor, select the virtual serial port, and check the **Yield CPU on poll** check box. This configuration option forces the affected virtual machine to yield processor time if the only task it is trying to do is poll the virtual serial port.

## Changing the Input Speed of the Serial Connection

To use the second option, power off the virtual machine and close the VMware Workstation window, then use a text editor to add the following line to your virtual machine's configuration file:

```
serial<n>.pipe.charTimePercent = <x>
```

This option is useful if you want to squeeze every possible bit of speed from your serial connection over a pipe to the virtual machine. In principle, there is no limit on the output speed — the speed at which the virtual machine sends data through the virtual serial port. In practice, the output speed depends on how fast the application at the other end of the pipe reads data inbound to it.

<n> is the number of the serial port, starting from 0. So the first serial port is `serial0`.

<x> is any positive integer. It specifies the time taken to transmit a character, expressed as a percentage of the default speed set for the serial port in the guest operating system. For example, a setting of 200 forces the port to take twice as long per character, or send data at half the default speed. A setting of 50 forces the port to take only half as long per character, or send data at twice the default speed.

You should first use the guest operating system to configure the serial port for the highest setting supported by the application you are running in the virtual machine.

Once the serial port speed is set appropriately in the guest operating system, experiment with this setting. Start with a value of 100 and gradually decrease it until you find the highest speed at which your connection works reliably.

## Examples: Debugging over a Virtual Serial Port

You can use Debugging Tools for Windows (`WinDbg`) or Kernel Debugger (`KD`) to debug kernel code in a virtual machine over a virtual serial port. You can download Debugging Tools for Windows from the Windows DDK Web site at [www.microsoft.com/whdc/devtools/debugging/default.mspix](http://www.microsoft.com/whdc/devtools/debugging/default.mspix).

The following two examples illustrate how to use a virtual serial port to debug kernel code in a virtual machine:

- With the debugging application on the VMware Workstation host (Windows hosts only)
- With the debugging application in another virtual machine on the same VMware Workstation host (useful on a Linux host and can also be done on a Windows host)

Using either of these methods lets you debug kernel code on one system, without the need for two physical computers, a modem or serial cable.

### Debugging an Application in a Virtual Machine from the Windows Host

In this example, you have kernel code to debug in a virtual machine (called the target virtual machine) and are running `WinDbg` or `KD` on your Windows host.

To prepare the target virtual machine, follow the steps for a Windows host in [Connecting an Application on the Host to a Virtual Machine on page 380](#). Make sure you configure the virtual machine's virtual serial port as follows:

- Select **This end is the server**
- Under **I/O Mode**, select the **Yield CPU on poll** check box, as the kernel in the target virtual machine uses the virtual serial port in polled mode, not interrupt mode

To prepare the host, make sure you have a recent version of Debugging Tools for Windows — one that supports debugging over a pipe. You need version 5.0.18.0 or higher.

When you are ready to begin, complete the following steps:

1. Power on the virtual machine.
2. Check to make sure the serial port is connected. Choose **VM > Removable Devices**. On that menu, **serial<n>** should be reported as `\\.\pipe\<namedpipe>` (on Windows hosts) or `/tmp/<socket>` (on Linux hosts). If the serial port is not connected, choose the virtual serial port, then **Connect**.
3. On the host, open a Command Prompt window and do one of the following:
  - If you are using `WinDbg`, type the following:
 

```
windbg -k com:port=\\.\pipe\<namedpipe>,pipe
```
  - If you are using `KD`, type the following:
 

```
kd -k com:port=\\.\pipe\<namedpipe>,pipe
```

Then press Enter to start debugging.

### Debugging an Application in a Virtual Machine from another Virtual Machine

In this situation, you have kernel code to debug in a virtual machine (called the target virtual machine) and are running Debugging Tools for Windows (`WinDbg`) or Kernel Debugger (`KD`) in another virtual machine (called the debugger virtual machine) on the same host.

This is useful if you are running VMware Workstation on a Linux host. The debugger virtual machine must be running Debugging Tools for Windows (`WinDbg`) or Kernel Debugger (`KD`) in a Windows guest operating system.

To prepare the target virtual machine, follow the steps for the server virtual machine for the appropriate host in [Connecting Two Virtual Machines on page 382](#). Make sure when you configure the target virtual machine's virtual serial port that you select the **Yield CPU on poll** check box, as the kernel in the target virtual machine uses the virtual serial port in polled mode, not interrupt mode.

To prepare the debugger virtual machine, make sure you have downloaded Debugging Tools for Windows. Then follow the steps for the client virtual machine in [Connecting Two Virtual Machines on page 382](#).

When you are ready to begin, complete the following steps:

1. Power on both virtual machines.
2. Check to make sure the serial port is connected. Choose **VM > Removable Devices**. If the serial port is not connected, choose the virtual serial port, then **Connect**.
3. In the debugger virtual machine, start debugging with `WinDbg` or `KD` normally.

# Keyboard Mapping on a Linux Host

This section addresses the following issues and provides additional details on keyboard mapping in Linux:

- My (language-specific) keyboard is not supported by VMware Workstation.
- Some of the keys on my keyboard don't work right in the virtual machine.
- My keyboard works fine when I run a virtual machine locally, but not when I run the same virtual machine with a remote X server.

## Quick Answers

If your keyboard works correctly with a local X server, and you just want the same behavior with a remote X server (which is also an XFree86 server running on a PC), just power off the virtual machine and close the VMware Workstation window, then add the line

```
xkeymap.usekeycodeMapIfXFree86 = true
```

to the virtual machine configuration file or to `~/ .vmware/config`. Make this change on the host machine, where you run the virtual machine, not on the machine with the remote X server.

If you are using an XFree86-based server that VMware Workstation does not recognize as an XFree86 server, use this instead:

```
xkeymap.usekeycodeMap = true
```

If you are using an XFree86 server running locally, and the keyboard does not work correctly, please report the problem to the VMware technical support department.

## The Longer Story

Unfortunately, keyboard support for the PC (virtual or otherwise) is a complex affair. To do it justice, we have to start with some background information — greatly simplified.

Pressing a key on the PC keyboard generates a scan code based roughly on the position of the key. For example, the Z key on a German keyboard generates the same code as the Y key on an English keyboard, because they are in the same position on the keyboard. Most keys have one-byte scan codes, but some keys have two-byte scan codes with prefix 0xe0.

Internally, VMware Workstation uses a simplified version of the PC scan code that is a single nine-bit numeric value, called a v-scan code. A v-scan code is written as a three-digit hexadecimal number. The first digit is 0 or 1. For example, the left-hand Ctrl key has a one-byte scan code (0x1d); its v-scan code is 0x01d. The right-hand Ctrl key scan code is two bytes (0xe0, 0x1d); its v-scan code is 0x11d.

An X server uses a two-level encoding of keys. An X key code is a one-byte value. The assignment of key codes to keys depends on the X server implementation and the physical keyboard. As a result, an X application normally cannot use key codes directly. Instead, the key codes are mapped into keysyms that have names like space, escape, x and Z. The mapping can be controlled by an X application via the function `XChangeKeyboardMapping()` or by the program `xmodmap`. To explore keyboard mappings, you can use `xev`, which shows the key codes and keysyms for keys typed into its window.

To recap, a key code corresponds roughly to a physical key, while a keysym corresponds to the symbol on the key top. For example, with an XFree86 server running on a PC, the Z key on the German keyboard has the same key code as the Y key on an English keyboard. The German Z keysym, however, is the same as the English Z keysym, and different from the English Y keysym.

For an XFree86 server on a PC, there is a one-to-one mapping from X key codes to PC scan codes (or v-scan codes, which is what VMware Workstation really uses). VMware Workstation takes advantage of this fact. When it is using an XFree86 server on the local host, it uses the built-in mapping from X key codes to v-scan codes. This mapping is keyboard independent and should be correct for most, if not all, languages. In other cases (not an XFree86 server or not a local server), VMware Workstation must map keysyms to v-scan codes, using a set of keyboard-specific tables.

Key code mapping is simple, automatic and foolproof. (Keysym mapping is more complex and described later.) However, because the program cannot tell whether a remote server is running on a PC or on some other kind of computer, it errs on the safe side and uses key code mapping only with local X servers. This is often too conservative and has undesirable effects. Luckily, this and other behavior related to key code-mapping can be controlled by powering off the virtual machine and closing the VMware Workstation window, then using a text editor to add configuration settings to the virtual machine's configuration file.

- `xkeymap.usekeycodeMapIfXFree86 = true`  
Use key code mapping if you are using an XFree86 server, even if it is remote.
- `xkeymap.usekeycodeMap = true`  
Always use key code mapping regardless of server type.

- `xkeymap.nokeycodeMap = true`  
Never use key code mapping.
- `xkeymap.keycode.<code> = <v-scan code>`  
If using key code mapping, map key code `<code>` to `<v-scan code>`. In this example, `<code>` must be a decimal number and `<v-scan code>` should be a C-syntax hexadecimal number (for example, `0x001`).

The easiest way to find the X key code for a key is to run `xev` or `xmodmap -pk`. Most of the v-scan codes are covered in [V-Scan Code Table on page 393](#). The keysym mapping tables described in this section are also helpful.

Use this feature to make small modifications to the mapping. For example, to swap left Ctrl and Caps Lock, use the following lines:

```
xkeymap.keycode.64 = 0x01d # X Caps_Lock -> VM left ctrl
xkeymap.keycode.37 = 0x03a # X Control_L -> VM caps lock
```

These configuration lines can be added to the individual virtual machine configuration, to your personal VMware Workstation configuration (`~/ .vmware/config`), or even to the host-wide (`/etc/vmware/config`) or installation-wide (usually `/usr/local/lib/vmware/config`) configuration.

When key code mapping cannot be used (or is disabled), VMware Workstation maps keysyms to v-scan codes. It does this using one of the tables in the `xkeymap` directory in the VMware Workstation installation (usually `/usr/local/lib/vmware`).

Which table you should use depends on the keyboard layout. The normal distribution includes tables for PC keyboards for the United States and a number of European countries and languages. And for most of these, there are both the 101-key (or 102-key) and the 104-key (or 105-key) variants.

VMware Workstation automatically determines which table to use by examining the current X keymap. However, its decision-making process may sometimes fail. In addition, each mapping is fixed and may not be completely right for any given keyboard and X key code-to-kevsym mapping. For example, a user may have swapped Ctrl and Caps Lock using `xmodmap`. This means the keys are swapped in the virtual machine when using a remote server (kevsym mapping) but unswapped when using a local server (key code mapping).

Therefore, keysym mapping is necessarily imperfect. To make up for this defect, you can change most of the behavior using configuration settings:

- `xkeymap.language = <keyboard-type>`  
Use this if VMware Workstation has a table in `xkeymap` for your keyboard but can't detect it. `<keyboard-type>` must be one of the tables in the `xkeymap` directory. (See above for location.) However, the failure to detect the keyboard probably means the table isn't completely correct for you.
- `xkeymap.keysym.<sym> = <v-scan code>`  
If you use keysym mapping, map keysym `<sym>` to `<v-scan code>`. When you do, `<sym>` must be an X keysym name and `<v-scan code>` should be a C-syntax hexadecimal number (for example, `0x001`).

The easiest way to find the keysym name for a key is to run `xev` or `xmodmap -pk`.

The X header file `/usr/X11R6/include/X11/keysymdef.h` has a complete list of keysyms. (The name of a keysym is the same as its C constant without the `XK_` prefix.) Most v-scan codes are in [V-Scan Code Table on page 393](#).

The `xkeymap` tables themselves are also helpful. Use them to fix small errors in an existing mapping.

- `xkeymap.fileName = <file-path>`  
Use the keysym mapping table in `<file-path>`. A table is a sequence of configuration lines of the form  
`<sym> = <v-scan code>`  
where `<sym>` is an X keysym name, and `<v-scan code>` is a C-syntax hexadecimal number (for example, `0x001`). (See the explanation of `xkeymap.keysym` above for tips on finding the keysyms and v-scan codes for your keyboard.)

Compiling a complete keysym mapping is difficult. It is best to start with an existing table and make small changes.



## V-Scan Code Table

These are the v-scan codes for the 104-key U.S. keyboard:

Symbol	Shifted symbol	Location	V-scan code
Esc			0x001
1	!		0x002
2	@		0x003
3	#		0x004
4	\$		0x005
5	%		0x006
6	^		0x007
7	&		0x008
8	*		0x009
9	(		0x00a
0	)		0x00b
-	_		0x00c
=	+		0x00d
Backspace			0x00e
Tab			0x00f
Q			0x010
W			0x011
E			0x012
R			0x013
T			0x014
Y			0x015
U			0x016
I			0x017
O			0x018
P			0x019
[	{		0x01a
]	}		0x01b
Enter			0x01c
Ctrl		left	0x01d

Symbol	Shifted symbol	Location	V-scan code
A			0x01e
S			0x01f
D			0x020
F			0x021
G			0x022
H			0x023
J			0x024
K			0x025
L			0x026
;			0x027
'			0x028
`			0x029
Shift		left	0x02a
\			0x02b
Z			0x02c
X			0x02d
C			0x02e
V			0x02f
B			0x030
N			0x031
M			0x032
,	<		0x033
.	>		0x034
/	?		0x035
Shift		right	0x036
*		numeric pad	0x037
Alt		left	0x038
Space bar			0x039
Caps Lock			0x03a
F1			0x03b
F2			0x03c

Symbol	Shifted symbol	Location	V-scan code
F3			0x03d
F4			0x03e
F5			0x03f
F6			0x040
F7			0x041
F8			0x042
F9			0x043
F10			0x044
Num Lock		numeric pad	0x045
Scroll Lock			0x046
Home	7	numeric pad	0x047
Up arrow	8	numeric pad	0x048
PgUp	9	numeric pad	0x049
-		numeric pad	0x04a
Left arrow	4	numeric pad	0x04b
5		numeric pad	0x04c
Right arrow	6	numeric pad	0x04d
+		numeric pad	0x04e
End	1	numeric pad	0x04f
Down arrow	2	numeric pad	0x050
PgDn	3	numeric pad	0x051
Ins	0	numeric pad	0x052
Del		numeric pad	0x053
F11			0x057
F12			0x058
Break	Pause		0x100
Enter		numeric pad	0x11c
Ctrl		right	0x11d
/		numeric pad	0x135
SysRq	Print Scrn		0x137
Alt		right	0x138

Symbol	Shifted symbol	Location	V-scan code
Home		function pad	0x147
Up arrow		function pad	0x148
Page Up		function pad	0x149
Left arrow		function pad	0x14b
Right arrow		function pad	0x14d
End		function pad	0x14f
Down arrow		function pad	0x150
Page Down		function pad	0x151
Insert		function pad	0x152
Delete		function pad	0x153
Windows		left	0x15b
Windows		right	0x15c
Menu			0x15d

The 84-key keyboard has a Sys Req key on the numeric pad:

Symbol	Shifted symbol	Location	V-scan code
Sys Req		numeric pad	0x054

Keyboards outside the U.S. usually have an extra key (often < > or < > |) next to the left shift key:

Symbol	Shifted symbol	Location	V-scan code
<	>		0x056

## Using USB Devices in a Virtual Machine

VMware Workstation 5 provides a two-port USB 1.1 controller. You can use up to two USB devices in your virtual machine if both your host operating system and your guest operating system support USB. If your host computer supports USB 2.0 devices, you can use those devices in the virtual machine.

Experimental support is provided for isochronous USB devices, such as webcams, speakers, and microphones.

**Note:** Windows NT and Linux kernels older than 2.2.17 do not support USB.

Although your host operating system must support USB, you do not need to install device-specific drivers for your USB devices in the host operating system if you want to use those devices only in the virtual machine.

On a Windows 2000 host computer with USB 2.0 support, be sure you are using the Microsoft USB 2.0 driver for the USB controller. Third-party USB 2.0 drivers, such as those provided by some motherboard manufacturers, are not supported. For notes on replacing the third-party drivers, see [Replacing USB 2.0 Drivers on a Windows 2000 Host on page 399](#).

### Notes on USB Support in Version 5

We have tested a variety of USB devices with this release. In general, if the guest operating system has appropriate drivers, you should be able to use PDAs, printers, storage (disk) devices, scanners, MP3 players, digital cameras and memory card readers.

Modems and certain streaming data devices, such as speakers and Web cams, do not work properly.

### Enabling and Disabling the USB Controller

The virtual machine's USB ports are enabled by default. If you will not be using USB devices in a virtual machine, you can disable its USB controller using the virtual machine settings editor.

## Connecting USB Devices

When a virtual machine is running, its window is the active window and a USB device is plugged into the host computer, the device automatically connects to the guest instead of the host. This autoconnect feature can be disabled in the USB Controller panel of the virtual machine settings editor (**VM > Settings**). If all of the virtual machine's USB ports are already occupied when it is trying to connect automatically to a new device, a dialog box gives you a choice: you can either disconnect one of the existing USB devices to free its port or ignore the new device, allowing the device to connect to the host.

Choose **VM > Removable Devices** to connect specific USB devices to your virtual machine. You can connect up to two USB devices at a time. If the physical USB devices are connected to the host computer through a hub, the virtual machine sees only the USB devices, not the hub.

There is a menu item for each of the USB ports. Move the mouse over one of these items to see a cascading menu of devices that are plugged into your host computer and available for use. To connect a device to the virtual machine, click its name.

If a device is already connected to that port, click the name of a new device to release the first device and connect the new one.

To release a connected device, click **None** on the cascading menu for the port to which it is connected.

If you physically plug a new device into the host computer and the autoconnect feature does not connect it to a virtual machine, the device is initially connected to the host. Its name is also added to the **VM > Removable Devices** menu so you can connect it to the virtual machine manually.

## Using USB with a Windows Host

**Windows 2000, Windows XP and Windows Server 2003 hosts:** When a particular USB device is connected to a virtual machine for the first time, the host detects it as a new device named VMware USB Device and installs the appropriate VMware driver.

**Windows XP and Windows Server 2003 hosts:** User confirmation is required in the Found New Hardware Wizard. Select the default action — **Install the software automatically**. Once the software is installed, the guest operating system detects the USB device and searches for a suitable driver.

When you are synchronizing a PDA, such as a Palm handheld or Handspring Visor, to a virtual machine for the first time, the total time required to load the VMware USB device driver in the host and the PDA driver in the guest may exceed the device's connection timeout value. This causes the device to disconnect itself from the computer before the guest can synchronize with it. If this occurs, let the guest finish installing the PDA driver, dismiss any connection error warnings, then try synchronizing the PDA again. The second attempt should succeed.

## Replacing USB 2.0 Drivers on a Windows 2000 Host

To use VMware Workstation 5 on a Windows 2000 host that has USB 2.0 ports, you must use the Microsoft USB 2.0 drivers for the USB controller in the host operating system. If your host operating system is using a third-party driver — a driver supplied by your motherboard vendor, for example — you must replace it.

Take the following steps to check the provider of your driver:

1. Go to the Device Manager. Right-click **My Computer**, choose **Properties**, click the **Hardware** tab, then click **Device Manager**.
2. Expand the listing for Universal Serial Bus controllers.
3. Right-click the listing for the controller and choose **Properties**.
4. Click the **Driver** tab. If the driver provider shown on that page is Microsoft, you have the correct driver already.

If the driver provider is not Microsoft, download the latest USB driver for your host operating system from the Microsoft Web site and follow the Microsoft instructions to install it. Details are available in Microsoft knowledge base article 319973.

## Using USB with a Linux Host

On Linux hosts, VMware Workstation uses the USB device file system to connect to USB devices. In most Linux systems that support USB, the USB device file system is at

`/proc/bus/usb`.

If your host operating system uses a different path to the USB device file system, you can change it in the virtual machine configuration `.vmx` file. Add the following line to change the default usb device file system path:

```
usb.generic.devfsPath = "<your_path_to_usbdevfs>"
```

## What Has Control over a USB Device?

Only one computer — host or guest — can have control of a USB device at any one time.

### Device Control on a Windows Host

When you connect a device to a virtual machine, it is “unplugged” from the host or from the virtual machine that previously had control of the device. When you disconnect a device from a virtual machine, it is “plugged in” to the host.

**Caution:** On Windows 2000, Windows XP and Windows Server 2003 hosts, you need to take a special step to disconnect USB network and storage devices from the host. There is a system tray icon called Eject Hardware on Windows 2000 and Safely Remove Hardware on Windows XP and Windows Server 2003. Use this icon to disconnect the device from the host before connecting it to a virtual machine.

### Device Control on a Linux Host

On Linux hosts, guest operating systems can use devices that are not already in use by the host — that is, devices that are not claimed by a host operating system driver.

If your device is in use by the host and you try to connect it to the guest using the **VM > Removable Devices** menu, a dialog box appears, informing you that there is a problem connecting to the device.

To disconnect the device from the host, you must unload the device driver. You can unload the driver manually as root (**su**) using the **rmmod** command. Or, if the driver was automatically loaded by **hotplug**, you can disable it in the **hotplug** configuration files in the **/etc/hotplug** directory. See your Linux distribution's documentation for details on editing these configuration files.

A related issue sometimes affects devices that rely on automatic connection (as PDAs often do).

If you have successfully used autoconnection to connect the device to your virtual machine, then experience problems with the connection to the device, take the following steps:

1. Disconnect and reconnect the device. You can either unplug it physically, then plug it back in or use the **VM > Removable Devices** menu to disconnect it and reconnect it.
2. If you see a dialog box warning that the device is in use, disable it in the **hotplug** configuration files in the **/etc/hotplug** directory.



## **Disconnecting USB Devices from a Virtual Machine**

Before unplugging a USB device or using the **VM > Removable Devices** menu to disconnect it from a virtual machine, be sure it is in a safe state.

You should follow the procedures the device manufacturer specifies for unplugging the device from a physical computer. This is true whether you are physically unplugging it, moving it from host to virtual machine, moving it between virtual machines or moving it from virtual machine to host.

This is particularly important with data storage devices (a Zip drive, for example). If you move a data storage device too soon after saving a file and the operating system has not actually written the data to the disk, you can lose data.

## **Human Interface Devices**

USB human interface devices, such as the keyboard and mouse, are not handled through the virtual machine's USB controller. Instead, they appear in the virtual machine as a standard PS/2 keyboard and mouse, even though they are plugged into USB ports on the host.

## Connecting to a Generic SCSI Device

Generic SCSI lets a virtual machine run any SCSI device that is supported by the guest operating system in the virtual machine. Generic SCSI gives the guest operating system direct access to SCSI devices connected to the host, such as scanners and tape drives.

### Generic SCSI on a Windows Host Operating System

Using the SCSI Generic driver in Windows, VMware Workstation allows your guest operating system to operate generic SCSI devices — including scanners, tape drives and other data storage devices — in a virtual machine.

**Note:** In order to access host SCSI devices as Generic SCSI devices from within a virtual machine, you must run VMware Workstation as a user with administrator access.

### Device Support

In theory, generic SCSI is completely device independent, but VMware has discovered it is sensitive to the guest operating system, device class and specific SCSI hardware. We encourage you to try any SCSI hardware you want to use and report problems to VMware technical support.

**Note:** If you are using generic SCSI devices in a Windows 95, Windows 98 or Windows Me guest operating system and are experiencing problems with the devices, download the latest Mylex® (BusLogic) BT/KT-958 compatible host bus adapter from [www.lsilogic.com](http://www.lsilogic.com). This driver overrides what Windows chooses as the best driver, but it corrects known problems.

### Preparing a Windows XP or Windows Server 2003 Guest Operating System to Use SCSI Devices

To use SCSI devices in a Windows XP or Windows Server 2003 virtual machine, you need a special SCSI driver available from the download section of the VMware Web site [www.vmware.com/download](http://www.vmware.com/download). Follow the instructions on the Web site to install the driver.

### Preparing a Windows NT 4.0 Guest Operating System to Use SCSI Devices

Generic SCSI devices use the virtual Mylex (BusLogic) BT/KT-958 compatible host bus adapter provided by the virtual machine. Some guest operating systems guide you through installing the drivers after you install the first SCSI device in the virtual machine. On Windows NT 4.0, however, you may need to install the driver manually, if it is not already installed for a virtual SCSI disk. You should do so before you add a generic SCSI device.

To install the BusLogic driver in a Windows NT 4.0 guest, have your Windows NT installation CD available and follow these steps.

1. Open the SCSI Adapters control panel.  
**Start > Settings > Control Panel > SCSI Adapters**
2. Click the **Drivers** tab.
3. Click **Add**.
4. In the list of vendors on the left, select **BusLogic**.
5. In the list of drivers on the right, select **BusLogic MultiMaster PCI SCSI Host Adapters**.
6. Click **OK**.
7. Insert the Windows NT CD when you are prompted. Click **OK**.
8. Reboot when you are prompted.

### Adding a Generic SCSI Device to a Virtual Machine

You can add generic SCSI devices to your virtual machine in the virtual machine settings editor. When you set up a generic SCSI device, the virtual machine must be powered off.

1. If it is not already running, launch VMware Workstation.  
**Start > Programs > VMware > VMware Workstation**
2. Open the virtual machine in which you want to use the generic SCSI device. Make sure the virtual machine is powered off.
3. From the VMware Workstation window, choose **VM > Settings**. The virtual machine settings editor opens.
4. Click **Add** to start the Add Hardware Wizard. Click **Next**.
5. Select **Generic SCSI Device**, then click **Next**.

6. Choose the name of the physical device you want to use.  
Then choose the virtual device node where you want this device to appear in the virtual machine.  
A check box under Device status allows you to specify whether the device should be connected each time the virtual machine is powered on.
7. Click **Finish** to install the new device.
8. Click **OK** to save the configuration and close the virtual machine settings editor.

To remove this device, launch the virtual machine settings editor, select the generic SCSI device, then click **Remove**.

### Generic SCSI on a Linux Host Operating System

Using the SCSI Generic driver in Linux, VMware Workstation allows your guest operating system to operate generic SCSI devices within a virtual machine. The SCSI Generic driver sets up a mapping for each SCSI device in `/dev`. Each entry starts with `sg` (for the SCSI Generic driver) followed by a letter. For example, `/dev/sga` is the first generic SCSI device.

Each entry corresponds to a SCSI device, in the order specified in `/proc/scsi/scsi`, from the lowest device ID on the lowest adapter to the highest device ID on the lowest adapter, and so on to the highest device ID on the highest adapter. Do not enter `/dev/st0` or `/dev/scd0`.

**Note:** When setting up a generic SCSI device in the virtual machine settings editor, as described later in this section, you specify the device you wish to install in the virtual machine by typing its `/dev/sg` entry in the **Connection** field. You must be logged on as a user who has permissions to use the device.

#### Requirements

Generic SCSI requires version 2.1.36 of the SCSI Generic (`sg . o`) driver, which comes with kernel 2.2.14 and higher.

### Avoiding Concurrent Access to a Generic SCSI Device

Under Linux some devices — specifically tape drives, disk drives and CD-ROM drives — already have a designated `/dev` entry (traditionally, `st`, `sd` and `scd`, respectively). When the SCSI Generic driver is installed, Linux also identifies these devices with corresponding `sg` entries in `/dev` — in addition to their traditional entries. VMware Workstation ensures that multiple programs are not using the same `/dev/sg` entry at the same time but cannot always ensure that multiple programs are not using the `/dev/sg` and the traditional `/dev` entry at the same time. It is important that you do not attempt to use the same device in both host and guest. This can cause unexpected behavior and may cause loss or corruption of data.

### Permissions on a Generic SCSI Device

You must have read and write permissions on a given generic SCSI device in order to use the device within a virtual machine, even if the device is a read-only device such as a CD-ROM drive. These devices typically default to root-only permissions. Your administrator should create a group with access to read and write to these devices, then add the appropriate users to that group.

### Device Support

In theory, generic SCSI is completely device independent, but VMware has discovered it is sensitive to the guest operating system, device class and specific SCSI hardware. We encourage you to try any SCSI hardware you want to use and report problems to VMware technical support.

**Note:** If you are using generic SCSI devices in a Windows 95, Windows 98 or Windows Me guest operating system and are experiencing problems with the devices, download the latest Mylex (BusLogic) BT/KT-958 compatible host bus adapter from [www.lsilogic.com](http://www.lsilogic.com). This driver overrides what Windows chooses as the best driver, but it corrects known problems. To use SCSI devices in a Windows XP or Windows Server 2003 virtual machine, you need a special SCSI driver available from the download section of the VMware Web site at [www.vmware.com/download](http://www.vmware.com/download).

### Adding a Generic SCSI Device to a Virtual Machine

You can add generic SCSI devices to your virtual machine in the virtual machine settings editor. The virtual machine settings editor lets you map virtual SCSI devices to physical generic SCSI devices on the host.

When you set up a generic SCSI device, the virtual machine must be powered off.

1. Launch VMware Workstation and select the virtual machine. Make sure the virtual machine is powered off.
2. Choose **VM > Settings**. The virtual machine settings editor opens.

3. Click **Add** to start the Add Hardware Wizard. Select **Generic SCSI Device**, then click **Next**.
4. Choose the name of the physical device you want to use.  
Then choose the virtual device node where you want this device to appear in the virtual machine.  
A check box under Device status allows you to specify whether the device should be connected each time the virtual machine is powered on.
5. Click **Finish** to install the new device.
6. Click **OK** to save the configuration and close the virtual machine settings editor.

To remove this device, launch the virtual machine settings editor, select the generic SCSI device, then click **Remove**.

# Performance Tuning

---

The following sections offer suggestions for getting the best performance from VMware Workstation and your virtual machines:

- [Configuring and Maintaining the Host Computer on page 408](#)
- [Configuring VMware Workstation on page 410](#)
- [Monitoring Virtual Machine Performance on page 416](#)
- [Memory Usage Notes on page 418](#)
- [Improving Performance for Guest Operating Systems on page 424](#)
- [Disk I/O Performance Tips on page 429](#)

# Configuring and Maintaining the Host Computer

The host computer is an obvious place to look to improve performance. This section discusses these key areas:

- [Location of the Working Directory on page 408](#)
- [Defragmentation of Disk Drives on page 408](#)
- [Adequate Free Disk Space on page 409](#)
- [NIC Interrupt Coalescing on page 409](#)

## Location of the Working Directory

The installer locates the working directory — holding the virtual disk files — on the host computer. You can customize your configuration to place the working directory or the virtual disk files on a different physical computer. There may be performance advantages to such customization.

## Defragmentation of Disk Drives

Host disks, virtual disks and guest disks all affect the performance of VMware Workstation. See [Defragmenting Virtual Disks on page 193](#) for the procedures.

### Host Hard Drives

Performance is weakened by fragmentation on the physical disk holding the virtual machine's working directory or virtual disk files. Fragmentation of the host disk can affect any or all of the following:

- The files that hold a virtual disk
- The files that store newly saved data when you have a snapshot
- The files that hold information used in suspending and resuming a virtual machine

If you are experiencing slow disk performance in the virtual machine, or if you want to improve the speed of suspend and resume operations, check to be sure the host disk that holds the virtual machine's working directory and virtual disk files is not badly fragmented. If it is fragmented, you can improve performance by running a defragmentation utility to reduce fragmentation on that host disk.



### Virtual Drives

Use the Workstation application to defragment virtual disks. See [Defragmenting Virtual Disks on page 193](#).

### Guest Operating System Drives

It is strongly recommended that you defragment using a guest operating system mechanism before taking the first snapshot (or linked clone).

- Workstation makes all its changes to the redo log, not to the original disk, when you run a defragmenting program on the guest after a snapshot. You lose the ability to defragment inside the original disk forever.
- Every sector that moves is copied to the redo log, making the virtual machine redo log extremely large when the disk is heavily fragmented and you run defragmentation after a snapshot.

### Performance Impact of Defragmenting Snapshots and Linked Clones

There may be a performance impact when you defragment a linked clone or a virtual machine with a snapshot. Exact performance degradation depends on:

- The fragmentation of the parent virtual machine disk when you created the snapshot or linked clone.
- The nature of the subsequent updates to the parent virtual machine disk.

Defragmentation tends to make the redo file grow. The redo file itself can become defragmented with respect to the host file system. If your use of virtual machines is strongly performance oriented, you should avoid defragmenting — or using — linked clones and snapshots.

### Adequate Free Disk Space

For better performance, avoid the situation of very low free space on the host disk. Performance can degrade considerably when VMware Workstation has to use a nearly-full host hard disk to write guest sparse disk, snapshot, checkpoint, or redo files.

### NIC Interrupt Coalescing

Increasing host NIC interrupt coalescing can improve performance for workloads involving heavy network traffic into the guest. Interrupt coalescing is a feature implemented in hardware under driver control on high-performance NICs, allowing the reception of a group of network frames to be notified to the operating system kernel via a single hardware interrupt.

# Configuring VMware Workstation

This section offers advice and information about factors that can affect the performance of VMware Workstation itself. This section does not address performance of the guest operating system or the host operating system.

**Note:** In addition to the VMware Workstation configuration options discussed below, you should always install VMware Tools in any guest operating system for which a VMware Tools package exists. Installing VMware Tools provides better video and mouse performance and also greatly improves the usability of the virtual machine. For details, see [Installing VMware Tools on page 120](#).

## General VMware Workstation Options

### Guest Operating System Selection

Make certain you select the correct guest operating system for each of your virtual machines. To check the guest operating system setting, choose **VM > Settings > Options > General**.

VMware Workstation optimizes certain internal configurations on the basis of this selection. For this reason, it is important to set the guest operating system correctly. The optimizations can greatly aid the operating system they target, but they may cause significant performance degradation if there is a mismatch between the selection and the operating system actually running in the virtual machine. (Selecting the wrong guest operating system should not cause a virtual machine to run incorrectly, but it may degrade the virtual machine's performance.)

### Memory Settings

Make sure to choose a reasonable amount of memory for your virtual machine. Many modern operating systems have a growing need for memory, so assigning a generous amount is a good thing.

The same holds true for the host operating system, especially a Windows host.

The New Virtual Machine Wizard automatically selects a reasonable starting point for the virtual machine's memory, but you may be able to improve performance by adjusting the settings in the virtual machine settings editor (**VM > Settings > Memory**).

If you plan to run one virtual machine at a time most of the time, a good starting point is to give the virtual machine half the memory available on the host.

Adjusting the application memory settings may also help. Go to **Edit > Preferences > Memory**.

For additional information, see [Memory Usage Notes on page 418](#).

### Debugging Mode

VMware Workstation can run in two modes — normal mode and a mode that provides extra debugging information. The debugging mode is slower than normal mode.

For normal use, check to be sure you are not running in debugging mode. Choose **VM > Settings > Options** and select **Advanced**. In the Advanced Options section, be sure there is no check in the **Run with debugging information** check box.

### CD-ROM Drive Polling

Some operating systems — including Windows NT and Windows 98 — poll the CD-ROM drive every second or so to see whether a disc is present. (This allows them to run autorun programs.) This polling can cause VMware Workstation to connect to the host CD-ROM drive, which can make it spin up while the virtual machine appears to pause.

If you have a CD-ROM drive that takes especially long to spin up, there are two ways you can eliminate these pauses.

- You can disable the polling inside your guest operating system. The method varies by operating system. For recent Microsoft Windows operating systems, the easiest way is to use TweakUI from the PowerToys utilities.

For information on finding TweakUI and installing it in your guest operating system, go to [www.microsoft.com](http://www.microsoft.com) and search for TweakUI. Specific instructions depend on your operating system.

- Another approach is to configure your virtual CD-ROM drive to start disconnected. The drive appears in the virtual machine, but it always appears to contain no disc (and VMware Workstation does not connect to your host CD-ROM drive).

To make this change, choose **VM > Settings**. Click the DVD/CD-ROM item in the **Device** list. Then clear the **Connect at Power On** check box.

When you want to use a CD-ROM in the virtual machine, choose **VM > Removable Devices** menu and connect the CD-ROM drive.

## Disk Options

The various disk options (SCSI versus IDE) and types (virtual or raw) affect performance in a number of ways.

Inside a virtual machine, SCSI disks and IDE disks that use direct memory access (DMA) have approximately the same performance. However, IDE disks can be very slow in a guest operating system that either cannot use or is not set to use DMA.

The easiest way to configure a Linux guest to use DMA for IDE drive access is to install VMware Tools (**VM > Install VMware Tools**). Among other things, the installation process automatically sets IDE virtual drives to use DMA.

In Windows 2000, DMA access is enabled by default. In other Windows guest operating systems, the method for changing the setting varies with the operating system. See the following technical notes for details.

- [Windows NT Disk Performance on Multiprocessor Hosts on page 427](#)
- [Windows 95 and Windows 98 Guest Operating System Performance Tips on page 424](#)

When a snapshot exists, virtual disks often have very good performance for random or nonsequential access. But they can potentially become so fragmented that performance is affected. In order to defragment the disk, you must first delete the snapshot (**VM > Snapshot > Snapshot Manager > Delete**).

When no snapshot exists, raw disks and virtual disks with all the space allocated in advance both use flat files that mimic the sequential and random access performance of the underlying disk. When a snapshot exists and you have made changes since powering on the virtual machine, any access to those changed files performs at a level similar to the performance of a virtual disk that does not have all space allocated in advance. If you delete the snapshot, performance is again similar to that of the underlying disk.

Overall, if no snapshot exists and you are using raw disks or virtual disks with all the space allocated in advance, you see somewhat better performance than that provided by other configurations.

Disk writes may be slower for virtual disks that do not have all space allocated in advance. However, you can improve performance for these disks by defragmenting them from the virtual machine settings editor. Choose **VM > Settings**, select the disk you want to defragment, then click **Defragment**.

### Remote Disk Access

Whenever possible, do not use disks that are on remote machines and accessed over the network unless you have a very fast network. If you must run disks remotely, choose **VM > Settings > Options**, select **General** and set the **Working directory** to a directory on your local hard disk. Then take a snapshot. After you take the snapshot, changes you make are stored locally in the working directory.

### Snapshot

If you do not need to use the snapshot feature, it is best to run your virtual machine with no snapshot. This provides best performance. To be sure a virtual machine has no snapshot, choose **VM > Snapshot > Snapshot Manager**. If you see a snapshot you do not want, select it and click the Delete button.

### Defragmentation

See [Defragmentation of Disk Drives on page 408](#) for information about keeping disk drives efficient.

## VMware Workstation on a Windows Host

**Note:** The items in this section describe performance of VMware Workstation on a Windows host. For tips on configuring VMware Workstation on a Linux host, see [VMware Workstation on a Linux Host on page 415](#).

- [Process Scheduling](#)
- [Windows Host Disk Caching](#)

### Process Scheduling

**Note:** The information in this section was created to address scheduling problems with Windows NT. Although Windows NT is no longer supported as a host OS, VMware currently has no corresponding information for Windows 2000, Windows XP or Windows Server 2003 hosts.

The process scheduler on Windows NT does not necessarily schedule processes in a way that allows you to get the best performance from your particular combination of virtual machines and applications running on the host. VMware Workstation on a Windows host provides configuration options that let you adjust scheduling priorities to meet your needs.

These configuration options are available from the **Edit > Preferences > Priority** and **VM > Settings > Options > Advanced** menu options. These menu items allow you to specify either high or normal priority when the mouse and keyboard are grabbed by the virtual machine and either normal or low priority when they are not grabbed.

Global priority is taken as the default across all virtual machines. Local priority overrides the global settings for just the specific virtual machine where you make the changes.

Pay particular attention to the **grabbed: HIGH – ungrabbed: NORMAL** and **grabbed: NORMAL – ungrabbed: LOW** settings.

The **grabbed: HIGH – ungrabbed: NORMAL** setting is useful if you have many background processes or applications and you do not care if they run with fairly low relative priority while VMware Workstation is in the foreground. In return, you get a very noticeable performance boost using a VMware Workstation virtual machine while another virtual machine is running or while some other processor-intensive task (a compile, for example) is running in the background.

The reverse is true of the **grabbed: NORMAL – ungrabbed: LOW** setting. If your host machine feels too sluggish when a virtual machine is running in the background, you can direct the virtual machine to drop its priority when it does not have control of the mouse and keyboard. As with the high setting, this is a heavy-handed change of priority, so the virtual machine and any background applications run much more slowly.

### **Windows Host Disk Caching**

On Windows Host, the Disk Properties Policies page associated with each hard drive provides a checkbox concerning enabling write caching on the disk and, in some cases, enabling advanced performance on the disk. Checking one or both of these boxes can improve host disk performance in general, and checking them for the host disks containing VMware virtual disk files can improve VMware disk performance in particular, especially when VMware is making heavy use of the disk.

**Caution:** Power outage or equipment failure could result in data loss or corruption with this option enabled.

## VMware Workstation on a Linux Host

**Note:** The items in this section describe performance of VMware Workstation on a Linux host. For tips on configuring VMware Workstation on a Windows host, see [VMware Workstation on a Windows Host on page 413](#).

### Using Full Screen Mode

Full screen mode is faster than window mode. As a result, if you do not need to have your virtual machine and your host sharing the screen, try switching to full screen mode.

**Note:** The extreme case of this is VGA mode. VGA mode is any mode in which the screen is in text mode (DOS, for example, or Linux virtual terminals), or 16-color 640 x 480 graphics mode (for example, the Windows 95 or Windows 98 clouds boot screen or any guest operating system that is running without the SVGA driver provided by VMware Tools).

On a Linux host, full screen VGA mode uses the underlying video card directly, so graphics performance is quite close to that of the host. By contrast, window mode VGA requires more computer resources to emulate than window mode SVGA. As a result, if you need to run for an extended period of time in VGA mode (for example, when you are installing an operating system using a graphical installer) you should see a significant performance boost if you run in full screen mode.

# Monitoring Virtual Machine Performance

VMware Workstation incorporates a set of performance counters that work with Microsoft's Performance console so you can collect performance data from running virtual machines.

**Note:** The Performance console is available only on Windows hosts. You cannot monitor performance for virtual machines on Linux hosts. However, you can monitor the performance of any virtual machines running on the Windows host, including those running Linux guest operating systems.

The VMware Workstation performance counters can monitor the following data from a running virtual machine:

- Reading and writing to virtual disks
- Memory used by the virtual machine
- Virtual network traffic

You can track virtual machine performance only when a virtual machine is running. The performance counters reflect the state of the virtual machine, not the guest operating system. For example, the counters can record how often a virtual machine reads from a virtual disk, but they cannot track how many processes are running inside the guest operating system. An explanation of each counter appears in the Performance console.

To add counters to track virtual machine performance, use the Windows Performance console. Take the following steps.

1. Open the Administrative Tools control panel and double-click **Performance**. The Performance console opens.



- Click the plus (+) sign on the toolbar. The Add Counters dialog box appears.

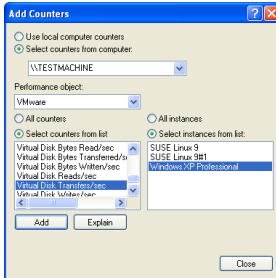

- In the Performance object list, select VMware.
  - Decide whether you want to add all counters or select specific counters from the list.
  - To use these counters for all running virtual machines, select **All instances**. To use the counters for specific virtual machines, select **Select instances from list**, then choose the virtual machines you want. The names shown in the list correspond to the display names of running virtual machines.
- Note:** For a brief description of each counter, click **Explain**. When you select a counter from the list, a description appears below the Add Counters dialog box.
- Click **Add** to add the counters to the Performance console.

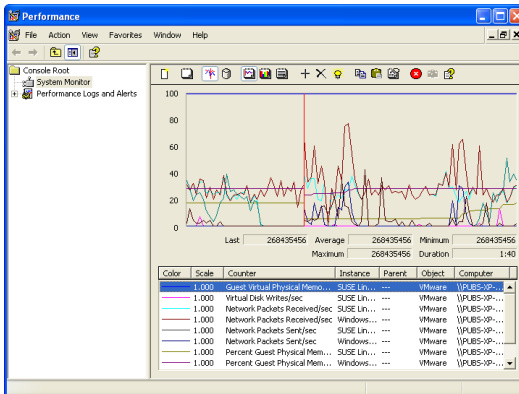

For more information about using the Performance console, choose **Action > Help** in the Performance console or go to the Microsoft Web site.

## Memory Usage Notes

VMware Workstation allows you to make the following memory-related settings:

- The memory size of a particular virtual machine
- The amount of the host computer's RAM that can be used for virtual machines.
- The extent to which you want to allow the host operating system's memory manager to swap virtual machines out of physical RAM

By adjusting these three settings, you can affect both virtual machine and overall system performance.

This section describes how VMware Workstation uses the memory configuration parameters to manage virtual machines and system memory properly.

### Virtual Machine Memory Size

The first configuration parameter you can set is the size of an individual virtual machine's memory. Set this configuration parameter for the virtual machine in the virtual machine settings editor (**VM > Settings > Memory**). The guest memory size should not be set lower than the minimum recommendations of the operating system provider.

The New Virtual Machine Wizard sets reasonable defaults for the memory size of a virtual machine, based on the type of the guest operating system and the amount of memory in the host computer. This value also appears in the virtual machine settings editor as the recommended memory value.

The virtual machine settings editor also shows a value for the maximum amount of memory for best performance. If you have only one virtual machine running on the host and you set virtual machine memory to this value, the virtual machine can run entirely in RAM. A virtual machine running completely in RAM performs better than a virtual machine that must swap some of its memory to disk.

The actual memory size you should give to a virtual machine depends on a few practical considerations:

- What kinds of applications will run in the virtual machine
- What other virtual machines will contend with this virtual machine for memory resources
- What applications will run on the host at the same time as the virtual machine

**Note:** You cannot allocate more than 2 GB of memory to a virtual machine when the virtual machine's files are stored on a host file system that does not support files greater than 2 GB — for example, FAT.

The total amount of memory you assign to all virtual machines running on a single host may not exceed 4 GB.

## Memory Use on the Host

Host operating systems do not behave well when they run low on free memory for their own use. When a Windows or Linux host operating system does not have enough RAM for its own use, it thrashes — it constantly swaps parts of itself between RAM and its paging file on disk. To help guard against virtual machines causing the host to thrash, VMware Workstation enforces a limit on the total amount of RAM that may be consumed by virtual machines.

Some memory must be kept available on the host to ensure the host is able to operate properly while virtual machines are running. The amount of memory reserved for the host depends on the host operating system and the size of the host computer's memory.

## Memory Sharing

Many workloads present opportunities for sharing memory across virtual machines. For example, several virtual machines may be running instances of the same guest operating system, have the same applications or components loaded or contain common data.

VMware Workstation uses a proprietary transparent page sharing technique to securely eliminate redundant copies of memory pages. With memory sharing, a workload often consumes less memory than it would when running on a physical machine. As a result, the system can support higher levels of overcommitment efficiently. The amount of memory saved by memory sharing is highly dependent on workload characteristics. A workload consisting of many nearly-identical virtual machines may free up more than 30 percent of memory, while a more diverse workload may result in savings of less than 5 percent of memory.

VMware Workstation memory sharing runs as a background activity that scans for sharing opportunities over time. The amount of memory saved may vary over time; for a fairly constant workload, the amount generally increases slowly until all sharing opportunities are exploited.

### Specifying How Much RAM Is Used by All Virtual Machines

The second configuration parameter you can set is the amount of RAM that VMware Workstation is allowed to reserve for all running virtual machines combined. To set this parameter, go to **Edit > Preferences > Memory**.

The reserved memory setting specifies a maximum amount of RAM that VMware Workstation is allowed to use. But this memory is not allocated in advance. Even if multiple virtual machines are running at the same time, VMware Workstation may be using only a fraction of the RAM you specify here. Any unused RAM is available to be used by other applications. If all the RAM you specify here is in use by one or more virtual machines, the host operating system cannot use this RAM itself or allow other applications to use it.

The RAM used by VMware Workstation includes the RAM made available to the guest operating systems plus a small amount of overhead memory associated with running a virtual machine.

The amount of RAM actually used for a particular virtual machine varies dynamically as a virtual machine runs. If multiple virtual machines run simultaneously, they work together to manage the memory.

The recommended amount of RAM to specify for all running virtual machines is calculated on the basis of the host computer's physical memory and appears in the reserved memory control — **Edit > Preferences > Memory**. If you want VMware Workstation to use more or less RAM, move this slider to change the amount.

If you set this value too high, the host may thrash when other applications are run on the host. If you set this value too low, virtual machines may perform very poorly and you cannot run as many virtual machines at once.

### Using Additional Memory

By default, VMware Workstation limits the number of virtual machines that can run at once based on the amount of memory specified in the application settings. This prevents virtual machines from causing each other to perform poorly.

To allow more or larger virtual machines to run, you can adjust a third setting — the amount of virtual machine memory that the host operating system may swap to disk. To change this setting, go to **Edit > Preferences > Memory** and change the additional memory setting. Select one of the following radio buttons:

- **Fit all virtual machine memory into reserved host RAM** — Strictly apply the reserved memory limit set in the top of the panel. This setting imposes the tightest restrictions on the number and memory size of virtual machines that may run at a given time. Because the virtual machines are running entirely in RAM, they have the best possible performance.
- **Allow some virtual machine memory to be swapped** — Allow the host operating system to swap a moderate amount of virtual machine memory to disk if necessary. This setting allows you to increase the number or memory size of virtual machines that can run on the host computer at a given time. It may also result in reduced performance if virtual machine memory must be shifted between RAM and disk.
- **Allow most virtual machine memory to be swapped** — Allow the host operating system to swap as much virtual machine memory to disk as it wants. This setting allows you to run even more virtual machines with even more memory than the intermediate setting does. In this case, too, performance may be lower if virtual machine memory must be shifted between RAM and disk.

## Using More Than 1GB of Memory on a Linux Host

By default, Linux kernels in the 2.2.x series support 1GB of physical memory. If you want to use more memory in Linux, you can take one of several approaches.

- Upgrade to a 2.4.x series kernel that allows for more physical memory.
- Recompile your kernel as a 2GB kernel using the `CONFIG_2GB` option.
- Enable the `CONFIG_BIGMEM` option to map more physical memory. (This approach requires special steps, described in detail in the Workarounds section below, to work with VMware products.)

The `CONFIG_2GB` option calls for recompiling your kernel as a 2GB kernel. You do this by recompiling your kernel with `CONFIG_2GB` enabled. This allows Linux to support nearly 2GB of physical memory by dividing the address space into a 2GB user section and a 2GB kernel section (as opposed to the normal division of 3GB for user and 1GB for kernel).

The third approach uses the `CONFIG_BIGMEM` option in Linux. With the `CONFIG_BIGMEM` option enabled, the kernel does not directly address all of physical memory and it can then map 1GB (or 2GB) of physical memory into the address space at a time. This allows the use of all of physical memory at the cost of changing the semantics the kernel uses to map virtual to physical addresses. However, VMware products expect physical memory to be mapped directly in the kernel's address space and thus do not work properly with the `CONFIG_BIGMEM` option enabled.

### Workarounds

If you are using a 1GB kernel with `CONFIG_BIGMEM` enabled and have 960MB to 1983MB of memory, VMware Workstation does not run. To work around this issue, you can either:

- Recompile the kernel as a 2GB kernel by enabling the `CONFIG_2GB` option. This allows for 100 percent use of physical memory.
- Pass the boot-time switch `mem=959M` at the LILO prompt, or add it to `lilo.conf`, to disable `CONFIG_BIGMEM` and thus allow you to run VMware Workstation. To do this:
  - At the LILO prompt, type `linux-2.2.16xxx mem=959M`.
  - Or, edit `lilo.conf`. In the kernel section, add this line:  
`append mem="959M"`

If you have a 1GB kernel with `CONFIG_BIGMEM` enabled and have more than 1983MB of memory, you can do one of the following:

- Recompile the kernel as a 2GB kernel by enabling the CONFIG\_2GB option and either pass the boot-time switch `mem=1983M` at the LILO prompt or add it to `lilo.conf`. To use the switch:
  - At the LILO prompt, type `linux-2.2.16xxx mem=1983M`.
  - Or, edit `lilo.conf`. In the kernel section, add this line:  
`append mem="1983M"`
- Pass the boot-time switch `mem=959M` at the LILO prompt or add it to `lilo.conf` to disable CONFIG\_BIGMEM. To use the switch:
  - At the LILO prompt, type `linux-2.2.16xxx mem=959M`.
  - Or, edit `lilo.conf`. In the kernel section, add this line:  
`append mem="959M"`

If you are using a 2GB kernel with CONFIG\_BIGMEM enabled and have 1984MB or more memory, VMware Workstation does not run. You can either pass the boot-time switch `mem=1983M` at the LILO prompt, or add it to `lilo.conf` to disable CONFIG\_BIGMEM and thus allow you to run VMware Workstation. To use the switch:

- At the LILO prompt, type `linux-2.2.16xxx mem=1983M`.
- Or, edit `lilo.conf`. In the kernel section, add this line:  
`append mem="1983M"`

# Improving Performance for Guest Operating Systems

The tips in this section help you make adjustments to improve performance for particular guest operating systems running inside a virtual machine.

- [Windows 95 and Windows 98 Guest Operating System Performance Tips on page 424](#)
- [Windows 2000, Windows XP and Windows Server 2003 Guest Operating System Performance Tips on page 426](#)
- [Windows NT Disk Performance on Multiprocessor Hosts on page 427](#)
- [Linux Guest Operating System Performance Tips on page 427](#)

See [Defragmentation of Disk Drives on page 408](#) for information about keeping disk drives efficient for all guest operating systems.

## Windows 95 and Windows 98 Guest Operating System Performance Tips

This section offers advice for configuring a Windows 95 or Windows 98 guest operating system for better performance inside a VMware Workstation virtual machine.

**Note:** This document pertains to the guest operating system that is running inside a VMware Workstation virtual machine. It does not describe actions that should be taken on the host.

### Guest Operating System Selection

Make certain you have selected the correct guest operating system in the virtual machine settings editor — **VM > Settings > Options**.

### VMware Tools

Make certain VMware Tools is installed. VMware Tools provides an optimized SVGA driver and sets up the VMware Tools service to run automatically when the system starts. Among other things, the VMware Tools service allows you to synchronize the virtual machine's clock with the host computer's clock, which can improve performance for some functions. You can install VMware Tools by choosing **VM > Install VMware Tools**.



### DMA Mode for IDE Disks

Windows 95 OSR2 and later (including Windows 98) can use direct memory access (DMA) for faster access to IDE hard disks. However, this feature may not be enabled by default.

You can turn on DMA access using the guest operating system's Device Manager.

1. Right-click **My Computer** and choose **Properties** from the pop-up menu.
2. Click the + sign beside **Disk Drives** to show your virtual machine's individual drives.
3. Right-click the entry for each IDE drive to open its Properties dialog box.
4. Under **Settings**, check the box labeled **DMA** and accept any warning Windows displays.
5. Restart Windows for the new settings to take effect.

### Full Screen Mode

Run your virtual machine in full screen mode. Click the **Full Screen** button on the VMware Workstation toolbar.

### Swap File Usage

In your `system.ini` file, in the `[386enh]` section, add the following line:

```
ConservativeSwapFileUsage=1
```

### Visual Effects

Windows 98 has a number of visual effects, designed to be attractive, that place unnecessary demands on the graphics emulation in VMware Workstation. Some users have seen performance improvements when they turn off these special effects.

To modify these settings, right-click on the desktop of your virtual machine, then select **Properties** from the pop-up menu. Click the **Effects** tab and uncheck the **Animate windows, menus, and lists** check box.

Also, if you have **Show window contents while dragging** checked, try unchecking that check box.

## Windows 2000, Windows XP and Windows Server 2003 Guest Operating System Performance Tips

This section offers advice for configuring a Windows 2000, Windows XP or Windows Server 2003 guest operating system for better performance inside a VMware Workstation virtual machine.

**Note:** This document pertains to the guest operating system that is running inside a VMware Workstation virtual machine. It does not describe actions that should be taken on Windows 2000, Windows XP or Windows Server 2003 running on the host computer.

### Guest Operating System Selection

Make certain you have selected the correct guest operating system in the virtual machine settings editor — **VM > Settings > Options**.

### VMware Tools

Make certain VMware Tools is installed. VMware Tools provides an optimized SVGA driver and sets up the VMware Tools service to run automatically when the system starts. Among other things, the VMware Tools service allows you to synchronize the virtual machine's clock with the host computer's clock, which can improve performance for some functions. You can install VMware Tools by choosing **VM > Install VMware Tools**.

### Visual Effects

The fade effects that Windows 2000, Windows XP and Windows Server 2003 use when displaying menus can be somewhat slow and make the virtual machine seem less responsive.

To disable the fade effects, right-click the guest operating system desktop, then choose **Properties > Appearance > Effects** (on Windows XP or Windows Server 2003) or **Properties > Effects** (on Windows 2000) and uncheck **Use transition effects for menus and tool tips**.

### Full Screen Mode

Run your virtual machine in full screen mode. Click the **Full Screen** button on the VMware Workstation toolbar.

## Windows NT Disk Performance on Multiprocessor Hosts

Some users have seen a problem in a VMware Workstation virtual machine using IDE virtual disks on a multiprocessor host computer. The I/O issue is especially noticeable when the virtual machine is booting.

**Note:** Performance in Windows NT guest operating systems may also be affected by disk fragmentation on the host computer. For details, see [Configuring and Maintaining the Host Computer on page 408](#).

### Improving Performance

You may increase performance by enabling DMA (direct memory access) on the virtual hard disk's IDE channel in the virtual machine.

If you have a virtual disk and a DVD/CD-ROM attached as master and slave to the primary IDE controller (channel 0) and you want to enable DMA, power off the virtual machine and use the virtual machine settings editor (**VM > Settings**) to move the DVD/CD-ROM drive to the secondary IDE controller (channel 1) at IDE 1:0.

You can enable the DMA feature after you finish installing Windows NT. You must install Service Pack 6a. Download **DMACHECK . EXE** from the Microsoft Web site ([support.microsoft.com/support/kb/articles/Q191/7/74.ASP](http://support.microsoft.com/support/kb/articles/Q191/7/74.ASP)) and run it.

Click the **Enabled** option for the IDE controller and channel configured for the virtual disk. Typically, this is channel 0 only, unless you have the virtual machine configured with multiple virtual disks and no virtual DVD/CD-ROM drive.

As noted above, you should not enable DMA on an IDE channel with a virtual DVD/CD-ROM drive attached.

## Linux Guest Operating System Performance Tips

This section offers advice for configuring a Linux guest operating system for better performance inside a VMware Workstation virtual machine.

**Note:** This document pertains to the guest operating system that is running inside a VMware Workstation virtual machine. It does not describe actions that should be taken on Linux running on the host.

### Guest Operating System Selection

Make certain you have selected the correct guest operating system in the virtual machine settings editor — **VM > Settings > Options**.

### VMware Tools

Make certain VMware Tools is installed. VMware Tools provides an optimized SVGA driver and sets up the VMware Tools service to run automatically when the system

starts. Among other things, the VMware Tools service allows you to synchronize the virtual machine's clock with the host computer's clock, which can improve performance for some functions. You can install VMware Tools by choosing **VM > Install VMware Tools**.

#### **Disconnect CD-ROM**

Using the **VM > Removable Devices** menu, disconnect your CD-ROM drive if you do not need to use it. Disconnecting CDROM devices reduces CPU usage.

#### **Install in Text Mode**

When you are installing your Linux guest operating system, use the text-mode installer instead of the graphical installer if you have a choice. This makes the installation process faster.

If you do use a graphical installer and if you are using a Linux host computer, try to run VMware Workstation in full screen mode during the installation.

#### **Full Screen Mode**

Run your virtual machine in full screen mode. Click the Full Screen button on the VMware Workstation toolbar.

# Disk I/O Performance Tips

## Memory Trimming

Workstation uses a memory trimming technique to de-allocate unused virtual machine memory for the host to re-allocate. Trimming usually has little impact on performance, and it may be needed in low memory situations. However, memory trimming can interfere with disk-oriented performance in a guest.

To disable memory trimming for a particular guest, add the following line to the virtual machine configuration (.vmx) file:

```
MemTrimRate=0
```

## Page Sharing

VMware uses a page sharing technique to allow guest memory pages with identical contents to be stored as a single copy-on-write page. Page sharing decreases host memory usage, but consumes system resources, potentially including I/O bandwidth.

You may want to avoid this overhead for guests for which host memory is plentiful and I/O latency is important. To disable page sharing, add the following line to the virtual machine configuration (.vmx) file:

```
sched.mem.pshare.enable=FALSE option
```



# Special-Purpose Configuration Options

---

The following sections describe how to use special-purpose configuration options:

- [Locking Out Interface Features on page 433](#)
- [Restricting the User Interface on page 435](#)
- [Using Full Screen Switch Mode on page 438](#)
- [Guest ACPI S1 Sleep on page 446](#)

In some situations you may find it useful to restrict a user's ability to reconfigure virtual machines and to simplify the user interface for inexperienced users. In a classroom, for example, you may want to ensure that virtual machine configurations remain consistent from one class session to the next.

The special-purpose configuration options available on Windows hosts meet these needs.

Administrative lockout is a global setting for VMware Workstation itself and affects all virtual machines. Restricted user interface affects only the specific virtual machines for which the setting has been made. Full screen switch mode affects the way VMware Workstation itself runs and, as a result, affects all virtual machines.

These options are available on Windows hosts only.



## Locking Out Interface Features

Administrative lockout is a global setting that affects all virtual machines for all users on a host computer. It allows a user to impose any combination of the following restrictions:

- Only a user who knows the password can create new virtual machines.
- Only a user who knows the password can edit virtual machine configurations.
- Only a user who knows the password can edit network settings.

**Note:** If no user has yet set administrative lockout preferences, any user may set them and set a password for access to the administrative lockout features. If any user has already set administrative lockout preferences, you must know the password in order to change the settings.

Take the following steps to set administrative lockout preferences:

1. Open the Application Settings dialog box (**Edit > Preferences**).
2. Click the **Lockout** tab. If a password is already set for the administrative lockout feature, enter the password when prompted.

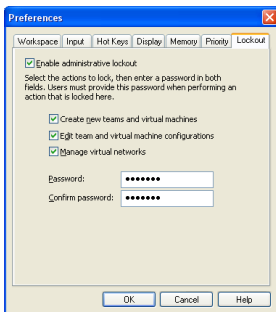

3. Be sure **Enable administrative lockout** is selected and select the actions you want to restrict. If this is the first time administrative lockout options have been set, enter a password in the **Password** field and again in the **Confirm password** field.
4. Click **OK** to save the settings.

## **Removing a Forgotten Password**

If you cannot remember the password and want to remove it, you must uninstall Workstation. Be sure to click **Yes** when asked if you want to remove the administrative lockout settings. After you reinstall Workstation, you may enable the administrative lockout features again and set a new password.

## Restricting the User Interface

The restricted user interface affects only the specific virtual machines for which the setting has been made. The following changes are made when you enable the restricted user interface:

- The toolbar is always hidden.
- All functions on the **Power** menu are disabled.
- All functions on the **Snapshot** menu and snapshot functions on the toolbar are disabled.
- There is no access to the virtual machine settings editor from the VMware Workstation window.
- The user cannot change virtual networking settings.
- The user starts the virtual machine by double-clicking the configuration file (. **vmx** file) or a desktop shortcut to that file. The virtual machine powers on automatically. At the end of the working session, the user shuts down by closing the virtual machine (**File > Exit**).

It is also possible to launch VMware Workstation, then open a restricted-interface virtual machine from the virtual machine list or the **File** menu.

The changes needed to enable the restricted user interface must be made by a user with sufficient privileges to edit the virtual machine's configuration file and to set file permissions as described below.

Take the following steps to enable the restricted user interface.

1. Power off the virtual machine and close the VMware Workstation window, then open the virtual machine's configuration file (. **vmx** file) in Notepad or another text editor. Add the following line anywhere in the file:

```
gui.restricted = "true"
```

2. You may wish to set file permissions on the configuration file to give normal users of the system only read access to the file, so they cannot manually modify the configuration.
3. For the convenience of users, create a shortcut to the configuration file on the desktop and give it an appropriate name.

**Note:** Although the restricted user interface provides no access to menu and toolbar controls for the snapshot, you may choose to give the user limited snapshot control. If you set up a snapshot for the restricted virtual machine and set the power-off option to **Ask me**, the user sees the standard dialog box when shutting down a virtual machine and has the opportunity to choose **Just power off**, **Take snapshot** or **Revert to snapshot**.

## Automatically Returning to a Snapshot with a Restricted User Interface

You can combine a restricted user interface with a snapshot to ensure that users' virtual machines always start in the same state. Typically, users running a virtual machine with a restricted user interface can power it on and off only, and the virtual machine boots when powered on. When the virtual machine has a snapshot set and is configured to return to that snapshot when powered off, the user can only start and power off the virtual machine. The virtual machine always starts from the snapshot.

Since you can restrict the user interface only on Windows hosts, this combination works only with virtual machines running on Windows hosts.

To set up a virtual machine with restricted user interface and a snapshot as described above, take the following steps:

1. Power on the virtual machine and be sure it is in the state you want, then take the snapshot.
2. Configure the virtual machine to return to the snapshot any time it is powered off. To do so, choose **VM > Settings > Options > Snapshots** and select **After powering off** and **Revert to snapshot**.
3. With the virtual machine powered off, restrict the user interface. Close the VMware Workstation window, then open the virtual machine's configuration file (.vmx file) in Notepad or another text editor. Add the following line anywhere in the file.  

```
gui.restricted = "true"
```
4. You may wish to set file permissions on the configuration file to give normal users of the system only read access to the file, so they cannot manually modify the configuration.
5. For the convenience of users, create a shortcut to the configuration file on the desktop and give it an appropriate name.

The user runs this virtual machine by double-clicking the shortcut to the configuration file. The virtual machine starts at the snapshot, with the user interface restricted — with no toolbar and no access to the Power menu or the virtual machine settings editor.

When the user is finished working with this virtual machine, he or she closes it by choosing **File > Close**. The virtual machine powers off, and the next time a user powers it on, it returns to the snapshot.

To remove the restriction on the interface, take the following steps.

1. Power off the virtual machine and close the VMware Workstation window.
2. Open the configuration file (`.vmx`) file and do one of the following:
  - Set `gui.restricted = "false"`.
  - Remove or comment out the `gui.restricted = "true"` line.Save the changes to the configuration file and close it.
3. Start the virtual machine by double-clicking the shortcut. The virtual machine starts at the snapshot, and the interface is not restricted.

## Using Full Screen Switch Mode

Full screen switch mode is a run-time option for the VMware Workstation program on Windows Hosts. When VMware Workstation is running in full screen switch mode, the user has no access to the VMware Workstation user interface. The user cannot create, reconfigure or launch virtual machines. A system administrator performs these functions.

When VMware Workstation is running in full screen switch mode, one or more virtual machines may be running and you can use hot keys to switch from one to another. You may also provide hot key access to the host operating system.

**Note:** Full screen switch mode is enabled for Windows hosts only. Linux hosts do not have full screen switch mode.

### Creating a Virtual Machine for Use in Full Screen Switch Mode

To create new virtual machines, you must run VMware Workstation in standard mode. The instructions in this section assume that you are creating the virtual machines on a separate administrative computer. However you may, if you prefer, create the virtual machines directly on the user's computer.

Create the new virtual machine following the instructions in [Creating a New Virtual Machine on page 101](#). Be sure to make the following choices:

- In step 5, select **Custom** to perform a custom installation.
- In step 8, make a note of the folder in which you create the virtual machine. You must copy all the files in this folder to the user's computer after you finish creating and configuring the virtual machine.
- In step 15, specify the desired size for the virtual disk and select **Allocate all disk space now**. This selection is not required, but it is strongly recommended. If you do not make this selection and the host computer's hard disk runs out of space for a growing virtual disk file, the user sees no warning message and does not know what is causing the problem in the virtual machine.

Make all needed configuration settings before you configure the user's computer to launch VMware Workstation when the computer starts. You cannot change Virtual Machine Settings using the virtual machine settings editor when VMware Workstation is running in full screen switch mode. You may find it most convenient to finish configuring the virtual machine and to install the guest operating system and application software before you move the virtual machine to the user's computer.

## Moving a Virtual Machine to the User's Computer

The easiest way to move the virtual machine to the user's computer is to use a network connection to copy all the files in the virtual machine directory to a directory on the user's computer. You may also move it using a DVD or other removable media large enough to store the files.

Each virtual machine should be in its own separate directory.

## Setting Configuration Options on the User's Computer

### Global Configuration Settings

Global configuration settings are made in the VMware Workstation global configuration file, created by default in the following locations:

- Windows Host:

```
C:\Documents and Settings\All Users\Application Data\VMware\VMware Workstation\config.ini.
```

- Linux Host:

```
/etc/vmware/config
```

**Note:** Full screen switch mode is enabled for Windows hosts only. This Linux configuration file path is provided for clarity and completeness.

You can edit this file with a text editor. You should set permissions on this file so the user cannot change it.

### Local Configuration Settings

Local configuration settings are made in the configuration file for a particular virtual machine. The local configuration file is in the virtual machine's directory; the filename has a `.vmx` extension.

The format for an entry in either configuration file is

```
option = "value"
```

Entries in the configuration files can appear in any order.

The hot key entries described in this section require you to enter a virtual key code as part of the value for an option. Virtual key codes are entered in hexadecimal format — as a hexadecimal number preceded by 0x. For example, to use the virtual key code of 5A as a value, type `0x5A`.

Microsoft provides a reference list of virtual key codes on the MSDN Web site. At the time this manual was written, the reference list was at [msdn.microsoft.com/library/en-us/winui/WinUI/WindowsUserInterface/UserInput/VirtualKeyCodes.asp](http://msdn.microsoft.com/library/en-us/winui/WinUI/WindowsUserInterface/UserInput/VirtualKeyCodes.asp).

The hot key entries also include modifier keys. The modifier keys are Ctrl, Alt and Shift, or a combination of those keys.

Modifier key	Value
No modifier	0x0
Alt	0x1
Ctrl	0x2
Shift	0x4
Ctrl-Alt	0x3
Alt-Shift	0x5
Ctrl-Shift	0x6
Ctrl-Alt-Shift	0x7

When listing a key plus a modifier, type the virtual key code for the key followed by a comma, then type the value for the modifier key or keys. For example, the value entry for Ctrl-Shift-F1 is `0x70, 0x6`.

**Note:** Keep the following limitations in mind when defining cycle keys and switch keys:

- Do not use the Pause key with the Ctrl key. You may use the Pause key with other modifier keys.
- If you use F12, you must use one or more modifier keys. You cannot use F12 alone.
- You cannot use combinations that include only the Shift, Ctrl and Alt keys. These keys may be used only as modifiers in combination with some other key.

### Hot Key for Cycling Through Virtual Machines and the Host Computer

You can specify a hot key or hot key combination for cycling through the available virtual machines on a host computer. Each time you press the specified hot key, the screen displays the next virtual machine in order. You may also include the host operating system in the cycle.

If any particular virtual machine is not running, it is skipped.

If only one virtual machine is running and the host operating system is not included in the cycle, pressing the hot key has no effect.



The hot key for cycling through virtual machines is defined in the global configuration file (`config.ini`).

Two options control cycling.

#### **FullScreenSwitch.cycleKey**

The value of this option defines the hot key. It is specified as `<key>`, `<modifier>`. There is no default.

For example, to use the Pause key with no modifier to cycle through virtual machines, add the following line to the `config.ini` file, or modify its value if the option is already listed.

```
FullScreenSwitch.cycleKey = "0x13,0x0"
```

#### **FullScreenSwitch.cycleHost**

The value of this option determines whether the host operating system is included in the cycle. Possible values are `true` and `false`. The default value is `false`.

For example, to include the host operating system in the cycle, add the following line to the `config.ini` file, or modify its value if the option is already listed:

```
FullScreenSwitch.cycleHost = "TRUE"
```

### **Hot Keys for Switching Directly to Virtual Machines and the Host Computer**

You can specify a hot key or hot key combination for switching directly to any available virtual machine on a host computer. Each time you press the specified hot key, the screen display switches to that of the specified virtual machine. You may also specify a hot key for switching directly to the host operating system.

If any particular virtual machine is not running, pressing the hot key for that virtual machine has no effect.

You define the hot key used to switch to a virtual machine by adding a line to the target virtual machine's configuration (`.vmx`) file. The value of this option defines the hot key. It is specified as `<key>`, `<modifier>`. There is no default.

For example, to use Ctrl-Shift-F1 to switch to a particular virtual machine, add the following line to that virtual machine's `.vmx` file, or modify its value if the option is already listed.

```
FullScreenSwitch.directKey = "0x70,0x6"
```

You define the hot key used to switch to the host operating system by adding a line to the global configuration file (`config.ini`). The value of this option defines the hot key. It is specified as `<key>`, `<modifier>`. There is no default.

For example, to use Ctrl-Shift-F9 to switch to the host operating system, add the following line to the `config.ini` file, or modify its value if the option is already listed.

```
FullScreenSwitch.hostDirectKey = "0x78,0x6"
```

### Other Entries in the Global Configuration File

The following entries in the global configuration file (`config.ini`) are optional. They enable you to control certain functions of the virtual machine that are important in work environments where virtual machines need to be isolated from each other and from the host computer.

#### `Isolation.tools.copy.enable`

The value of this option determines whether data in one virtual machine or the host operating system can be copied in a way that allows it to be transferred to another virtual machine or to the host operating system. Possible values are true (such copying is allowed) and false (such copying is not allowed). The default value is true. The setting for this option should be the same as the setting for

`Isolation.tools.paste.enable` (below).

#### `Isolation.tools.paste.enable`

The value of this option determines whether data copied in one virtual machine or the host operating system can be pasted into another virtual machine or the host operating system. Possible values are true (such pasting is allowed) and false (such pasting is not allowed). The default value is true. The setting for this option should be the same as the setting for `Isolation.tools.copy.enable` (above).

#### `Isolation.tools.HGFS.disable`

The value of this option determines whether virtual machines can be configured with shared folders, for sharing files among virtual machines and with the host computer. Possible values are true (shared folders are disabled) and false (shared folders are enabled). The default value is false.

The following entries are required in the global configuration file (`config.ini`) and must not be changed:

```
mks.ctrlAltDel.ignore = "TRUE"  
mks.fullscreen.allowScreenSaver = "TRUE"  
fullScreenSwitch.onSeparateDesktop = "TRUE"  
msg.autoAnswer = "TRUE"
```

## Starting and Stopping Virtual Machines on the User's Computer

Use the `vmware-fullscreen` command to run VMware Workstation in full screen switch mode and to start and stop virtual machines on a user's computer. The command can pass certain information to the virtual machine when it starts.

As administrator, you must decide how to issue the command. For example, you may use a custom application or script running on the host operating system to issue one or more `vmware-fullscreen` commands. Or you can include the command to start a virtual machine in a shortcut in the host operating system's startup group, so the virtual machine starts automatically when the user logs on to the host computer.

The `vmware-fullscreen` command must be issued once for each virtual machine you want to start or stop.

```
vmware-fullscreen -poweron [-s variable=value]
[-name=<alias>] [-directkey=<keyspec>] [-fullscreen]
"<config-file>"
```

When you use the optional switches shown here, the `-poweron` switch is required and must be the first switch after the `vmware-fullscreen` command. Provide the full path to the virtual machine's configuration (`.vmx`) file at the end of the command line. The complete command must be entered on one line.

Use the `-s` switch to pass a variable name and value to be used in configuring the virtual machine. You may include multiple `variable=value` pairs in the command. Each `variable=value` pair must be preceded by `-s`.

Use `-name=<alias>` to give a name to the virtual machine. You can use that alias in `-switchto` and `-poweroff` commands.

Use `-directkey=<keyspec>` to specify the virtual machine's direct-switch key. If a direct-switch key is specified in the virtual machine's configuration file, the one specified on the command line overrides the one in the configuration file.

For example, to start a virtual machine and specify that its direct-switch key combination is Ctrl-Shift-F1, use the following command:

```
vmware-fullscreen -poweron -directkey=0x70,0x6 "<config-file>"
```

The complete command must be entered on one line.

Use `-fullscreen` to start a virtual machine and go straight to full screen switch mode. The virtual machine takes over the display immediately, instead of running invisibly until the user switches to it later.

**Starting a Virtual Machine**

```
vmware-fullscreen -poweron "<config-file>"
```

Use this command to power on the virtual machine without passing any additional information to the virtual machine. Provide the full path to the virtual machine's configuration (. **vmx**) file.

The user sees no immediate indication that the virtual machine has started, but the user can switch to the virtual machine with its direct-switch key or with the cycle key.

**Stopping a Virtual Machine**

```
vmware-fullscreen -poweroff "<config-file>"
```

```
vmware-fullscreen -poweroff <alias>
```

Use this command to shut down the specified virtual machine. You can specify the path to the configuration (. **vmx**) file, or you can specify the alias if you used **-name=** when you started the virtual machine.

**Stopping All Virtual Machines**

```
vmware-fullscreen -exit
```

Use this command to power off all virtual machines cleanly. VMware Workstation exits as soon as all the virtual machines have powered off.

**Switching Among Virtual Machines and the Host**

```
vmware-fullscreen -switchto "<config-file>"
```

```
vmware-fullscreen -switchto <alias>
```

```
vmware-fullscreen -switchto host
```

```
vmware-fullscreen -switchto next
```

Use this command to switch to the specified virtual machine, to the host operating system, or to the next machine (virtual machine or host) in the cycling order. A virtual machine must already be powered on before you can switch to it. When specifying a virtual machine, you can specify the path to the configuration (. **vmx**) file, or you can specify the alias if you used **-name=** when you started the virtual machine.

**Checking the Status of VMware Workstation**

```
vmware-fullscreen -query
```

This command tells you if VMware Workstation is already running in full screen switch mode. If it is, the response to this command also reports its process ID and window handle.

**The vmware-fullscreen Log File**

The `vmware-fullscreen` program writes to a log file. This log file records errors reported by `vmware-fullscreen` itself as it starts, stops and passes other

commands to VMware Workstation. It is separate from the `vmware.log` file, which stores information on the running virtual machines.

The name of the `vmware-fullscreen` log file is `vmware-<username>-<pid>.log`. By default, the `vmware-fullscreen` log file is in the temp directory for the user logged on to the host computer. This location may be specified in the TEMP environment variable; by default, the location is `C:\Documents and Settings\<username>\Local Settings\Temp`.

The administrator can specify a different location for this log file by adding the following line to the VMware Workstation global configuration file (`config.ini`):

```
fullScreenSwitch.log.filename="<path>"
```

It is best to use a full path. If you use a relative path, the location is relative to the directory that is active when the `vmware-fullscreen` command is issued for the first time after the host computer reboots.

## Guest ACPI S1 Sleep

Workstation 5 provides experimental support for guest operating system ACPI S1 sleep. Not all guest operating systems support this feature. Common guest operating system interfaces for entering standby are supported.

By default, ACPI S1 sleep is implemented within Workstation as suspend. The Workstation resume button can be used to wake the guest.

With the following entry in the (.vmx) configuration file for a virtual machine:

```
chipset.onlineStandby = TRUE
```

ACPI S1 sleep is instead implemented as power-on suspend. The guest operating system is not fully powered down. You can awaken the virtual machine:

- Using keyboard input
- Using mouse input
- Through programming the CMOS external timer

This feature can be useful for test and development scenarios.

## Glossary

---

**Administrative Lockout** — a global setting providing password protection for Windows hosts. Administrative lockout restricts users from creating new virtual machines, editing virtual machine configurations, and changing network settings.

**Bridged networking** — A type of network connection between a virtual machine and the rest of the world. Under bridged networking, a virtual machine appears as an additional computer on the same physical Ethernet network as the host. See also [Host-only networking](#).

**Clone** — A duplicate copy of a virtual machine. See also [Full clone](#) and [Linked clone](#).

**Clone Virtual Machine wizard** — A point-and-click interface for convenient, easy duplication of a virtual machine within VMware Workstation. See also [Full clone](#), and [Linked clone](#)

**Configuration** — See [Virtual machine configuration file](#).

**Custom networking** — Any type of network connection between virtual machines and the host that does not use the default bridged, host-only or network address translation (NAT) networking configurations. For instance, different virtual machines

can be connected to the host by separate networks or connected to each other and not to the host. Any network topology is possible.

**Drag and drop** — With the drag and drop feature of VMware Workstation, you can move files easily between a Windows host and a Windows virtual machine. You can drag and drop individual files or entire directories.

**Existing partition** — A partition on a physical disk in the host machine.  
See also [Raw disk](#).

**Full clone** — A complete copy of the original virtual machine plus all associated virtual disks.  
See also [Linked clone](#).

**Full screen mode** — A display mode in which the virtual machine's display fills the entire screen.  
See also [Full screen switch mode](#), [Quick switch mode](#).

**Full screen switch mode** — A display mode in which the virtual machine's display fills the entire screen, and the user has no access to the VMware Workstation user interface. The user cannot create, reconfigure or launch virtual machines. A system administrator performs these function  
See also [Full screen mode](#).

**Favorites list** — A list in the left panel of the main VMware Workstation screen that shows the names of virtual machines that a user has added to the list. The Favorites list makes it easy to launch a virtual machine or to connect to the virtual machine's configuration file in order to make changes in the virtual machine settings.

**Go to Snapshot** — Go to a snapshot allows you to restore any snapshot of the active virtual machine.  
See also [Revert to snapshot](#).

**Guest operating system** — An operating system that runs inside a virtual machine.  
See also [Host operating system](#).

**Host-only networking** — A type of network connection between a virtual machine and the host. Under host-only networking, a virtual machine is connected to the host on a private network, which normally is not visible outside the host. Multiple virtual machines configured with host-only networking on the same host are on the same network.  
See also [Bridged networking](#), [Custom networking](#), and [Network address translation \(NAT\)](#).



**Host machine** — The physical computer on which the VMware Workstation software is installed. It hosts the VMware Workstation virtual machines.

**Host operating system** — An operating system that runs on the host machine. See also [Guest operating system](#).

**LAN segment** — A private virtual network that is available only to virtual machines within the same team.

See also [Virtual Network](#), and [Teams](#)

**Legacy virtual machine** — A virtual machine created for use in Workstation 4.x, GSX Server 3.x or ESX Server 2.x. You can use and create legacy virtual machines within Workstation 5, but new Workstation 5 features are not usable. For example: clones, multiple snapshots, and teams are not compatible with a legacy virtual machine.

**Linked clone** — A copy of the original virtual machine that shares the virtual disks with the original virtual machine in an ongoing manner.

See also [Full clone](#).

**Lockout** — see [Administrative Lockout](#).

**Network address translation (NAT)** — A type of network connection that allows you to connect your virtual machines to an external network when you have only one IP network address, and that address is used by the host computer. If you use NAT, your virtual machine does not have its own IP address on the external network. Instead, a separate private network is set up on the host computer. Your virtual machine gets an address on that network from the VMware virtual DHCP server. The VMware NAT device passes network data between one or more virtual machines and the external network. It identifies incoming data packets intended for each virtual machine and sends them to the correct destination.

**New Virtual Machine wizard** — A point-and-click interface for convenient, easy creation of a virtual machine configuration. It creates files that define the virtual machine, including a virtual machine configuration file and (optionally) a virtual disk or raw disk file.

See also [Virtual machine settings editor](#).

**Parent** — The source or “original” virtual machine from which you take a snapshot or make a clone. A full clone has no continued link to its parent, but a linked clone and a snapshot each depend on the parent in an ongoing manner. If you delete the parent virtual machine, any linked clone or snapshot becomes permanently disabled. To prevent deletion, you can create a template virtual machine.

See also [Full clone](#), [Linked clone](#), [Snapshot](#), and [Template](#).

**Quick switch mode** — A display mode in which the virtual machine's display fills most of the screen. In this mode, tabs at the top of the screen allow you to switch quickly from one running virtual machine to another.

See also [Full screen mode](#).

**Raw disk** — A hard disk in a virtual machine that is mapped to a physical disk drive or a partition of a drive on the host machine. A virtual machine's disk can be stored as a file on the host file system (see [Virtual disk](#)) or on a local hard disk. When a virtual machine is configured to use a raw disk, VMware Workstation directly accesses the local disk or partition as a raw device (not as a file on a file system). It is possible to boot a previously installed operating system on an existing partition within a virtual machine environment. The only limitation is that the existing partition must reside on a local IDE or SCSI drive.

See also [Virtual disk](#).

**Resume** — Return a virtual machine to operation from its suspended state. When you resume a suspended virtual machine, all applications are in the same state they were when the virtual machine was suspended.

See also [Suspend](#).

**Revert to snapshot** — Reverting to a snapshot restores the status of the active virtual machine to its immediate parent snapshot. This parent is represented in the snapshot manager by the snapshot appearing to the immediate left of the **You Are Here** icon.

See also [Go to Snapshot](#), [Snapshot manager](#), and [You Are Here \(icon\)](#).

**Shared folder** — A shared folder is a folder on the host computer — or on a network drive accessible from the host computer — that can be used by both the host computer and one or more virtual machines. It provides a simple way of sharing files between host and guest or among virtual machines. In a Windows virtual machine, shared folders appear as folders on a designated drive letter. In a Linux virtual machine, shared folders appear under a specified mount point.

**Snapshot** — A snapshot preserves the virtual machine just as it was when you took that snapshot — the state of the data on all the virtual machine's disks and whether the virtual machine was powered on, powered off or suspended. VMware Workstation lets you take snapshots of a virtual machine at any time and revert to that snapshot at any time. You can take a snapshot when a virtual machine is powered on, powered off or suspended. Configurations are available to exclude a disk from snapshots.

**Snapshot manager** — The snapshot manager is a window that allows you to take actions on any of the snapshots associated with the selected virtual machine.

See also [Snapshot](#).

**Suspend** — Saves the current state of a running virtual machine. To return a suspended virtual machine to operation, you use the resume feature.

See also [Resume](#).

**Teams** — A group of virtual machines that are configured to operate as one object. You can power on, power off, and suspend a team with one command. You can configure a team to communicate independently of any other virtual or real network by setting up a LAN segment.

See also [LAN segment](#), [Virtual Network](#).

**Template** — A virtual machine that cannot be deleted or added to a team. Setting a virtual machine as a template protects any linked clone or snapshots from being disabled inadvertently.

See also [Linked clone](#), [Parent](#), and [Snapshot](#).

**Virtual disk** — A file or set of files appearing as a physical disk drive to a guest operating system. These files can be on the host machine or on a remote file system. When you configure a virtual machine with a virtual disk, you can install a new operating system into the disk file without the need to repartition a physical disk or reboot the host.

See also [Raw disk](#).

**Virtual machine** — A virtualized x86 PC environment in which a guest operating system and associated application software can run. Multiple virtual machines can operate on the same host machine concurrently.

**Virtual machine configuration** — The specification of what virtual devices (disks, memory size, etc.) are present in a virtual machine and how they are mapped to host files and devices.

**Virtual machine configuration file** — A file containing a virtual machine configuration. It is created by the New Virtual Machine Wizard. It is used by VMware Workstation to identify and run a specific virtual machine.

**Virtual machine settings editor** — A point-and-click editor used to view and modify the settings of a virtual machine after its initial creation.

See also [New Virtual Machine wizard](#).

**Virtual Network** — A network between virtual machines with no dependence on real-world hardware connections. For example, you can create a virtual network between a virtual machine and a host that has no external network connections. You can also create a LAN segment for communications between virtual machines on a team

See also [LAN segment](#), and [Teams](#).

**Virtual Network Editor** — A point-and-click editor used to view and modify the networking settings for the virtual networks created by VMware Workstation.

**VMware Tools** — A suite of utilities and drivers that enhances the performance and functionality of your guest operating system. Key features of VMware Tools include some or all of the following, depending on your guest operating system: an SVGA driver, a mouse driver, the VMware Tools control panel and support for such features as shared folders, drag and drop in Windows guests, shrinking virtual disks, time synchronization with the host, VMware Tools scripts, and connecting and disconnecting devices while the virtual machine is running.

**You Are Here (icon)** — A special icon appearing in the snapshot manager that indicates the current status of the active virtual machine. This can be important when deciding whether to revert to, or go to a snapshot.

See also [Snapshot manager](#), [Revert to snapshot](#), and [Go to Snapshot](#).

# Index

## File extensions

- 201
- .bmp 165
- .cfg 98
- .dsk 97
- .log 96
- .nvram 96
- .png 165
- .REDO 97
- .std 97
- .tar 124
- .vmdk 97, 173, 176, 179, 191
- .vmsd 97
- .vmsn 97
- .vmss 97
- .vmtm 98
- .vmx 98, 429
  - locating for clone 281
- .vmxf 98
- .wav 369

## A

- Access
  - to raw disks 219, 241
- ACPI 446
- Adapter
  - host virtual 308
  - in promiscuous mode on a Linux host 344
  - virtual Ethernet 316
- Add
  - devices to virtual machine 164
  - DVD or CD drive 204
  - floppy drive 206
  - generic SCSI device 403, 405
  - host virtual adapter 323
  - parallel port 372
  - serial port 377
  - shared folder 157
  - software to virtual machine 155
  - virtual disk 197
  - virtual Ethernet adapter 316

- virtual machines, during new team wizard 280

## Address

- assigning IP 329
- assigning MAC manually 333
- IP in virtual machine 107
- IP on virtual network 327
- MAC 332
- network address translation 345
- using DHCP to assign on a virtual network 327

- Administrative lockout 433

## Assign

- drive letter 221
- IP address 327
- MAC address 332
- network port number in NAT 351

- Athlon 23

## Attach

- See Connect

## Audio

- See Sound

- AudioPCI 369

- Autofit 152

- guest 152

- autofit

- window 152

- Automatic bridging 318

- Autorun

- disable 40

## B

- Bandwidth

- LAN segment 282

- bandwidth

- LAN segment 300

- Basic disks

- on Windows host 234

- BIOS

- file in virtual machine 96
- provided in virtual machine 27

- Boot loader

- LILO 220, 223, 236

- Boot sequence
  - in VMware BIOS 221, 224
- Bridge 307
- Bridged networking
  - configuring options 318
  - defined 447
- Browser
  - configuring on Linux host 48
- BSD
  - supported guest operating systems 31
- BT-958 108, 235
- BusLogic 28, 108, 235, 402, 405
- C**
- Capacity
  - disk 188, 190, 202, 238
- Capture
  - screen shot of virtual machine 165
  - screenshot 165
- CD
  - adding drive to virtual machine 204
  - CD-ROM image file 27
- Celeron 23
- Centrino 23
- Change
  - See Configure
  - team name 302
  - virtual machine name 84
- Clock
  - real-time on Linux host 45
  - synchronize guest and host 131
- Clone
  - creating 270
  - creating clone in New Team Wizard 281
  - enable template mode 275
  - full 269
  - linked 269
  - network identity 273
  - new 270
  - overview 268
  - snapshot (for linked clone) 274
- Clone of clone
  - full clone of linked clone 273
  - Linked clone of linked clone 273
- clone of clone
  - full clone of linked clone 273
- Clone template
  - not on team 275
- Clone, linked
  - snapshot 274
- CODEC
  - movie 166
- Color
  - screen colors in a virtual machine 360
- Comm port
  - See Serial connection, Serial port 377
- Command line
  - vmrun 93
  - VMware 91
  - workstation 91
- Commands
  - keyboard shortcuts 95
  - on the command line 91
- Compress
  - See Shrink
- Configuration
  - virtual machine 451
- Configure
  - administrative lockout 433
  - after Linux kernel upgrade 48
  - automatic bridging 318
  - bridged networking 318
  - devices in virtual machine 164
  - DHCP on Linux host 328
  - DHCP on Windows host 328
  - DHCP settings 321
  - display resolution on a Linux host 362
  - full screen switch mode 438
  - generic SCSI device 402, 403, 405
  - host virtual network mapping 320
  - hot keys 78
  - memory size 418
  - memory use 80
  - NAT 348
  - NAT on Linux host 355
  - parallel port 372
  - parallel port on a Linux host 373
  - performance monitoring 416

- preferences for virtual machine 76, 83
  - process priorities on Windows host 81
  - restricted user interface 435
  - screen colors 360
  - second bridged network on a Linux host 336
  - serial port 377
  - shared folder 157
  - sound 369
  - USB controller 397
  - virtual Ethernet adapter 316
  - virtual network 309, 313, 316
  - virtual network subnet settings 321
  - VMware Tools 130
  - Web browser on Linux host 48
- Connect
  - removable devices 67, 132, 164
  - USB devices 398
- Controls
  - hiding 153
- Copy
  - text 156
  - virtual machine 174, 175, 177, 178, 181
  - virtual machine--see clone 268
- CPU
  - host requirement 23
  - provided in virtual machine 27
- Create
  - floppy image file 207
  - named pipe 380, 381, 382
  - virtual machine 101
- Creating
  - clone 270
- Creative Labs 29, 369
- Ctrl-Alt 78
- Cut
  - text 156
- D**
- Date
  - See Time
- DDNS 336
- Decrease
  - See Shrink
- Default
  - team location 280
  - team path 280
- Defragment
  - virtual disks 193
- Delete
  - virtual machine 148
  - virtual machine from Favorites list 73
- Devices
  - adding, configuring and removing 164
  - connecting and disconnecting 164
  - disconnecting from USB controller 401
  - in virtual machine 164
  - provided in virtual machine 27
  - USB 397
- Devices tab
  - tools 132
- DHCP
  - assigning IP addresses on a virtual network 327
  - changing settings 321
  - configuring on a Linux host 328
  - configuring on a Windows host 328
  - DHCPD 335
  - lease 322
  - on a virtual network with NAT 346
  - server 308, 322
  - server on virtual network 311, 312
  - stopping 342
  - troubleshooting on a Linux host 335
- Dial-up connection 331
- Direct memory access
  - See DMA
- Disable
  - autorun 40
  - DHCP 342
  - drag and drop 163
  - host virtual adapter 323
  - interface features 431
  - removable devices 67, 132
  - scripts 132
  - snapshot 265
  - Snapshot menu functions 435
  - USB controller 397

- Disabling
    - snapshot 254
    - snapshots 265
  - Disconnect
    - removable devices 67, 132, 164
    - USB devices 401
  - Disk
    - files on host 191
    - independent 194, 257
    - performance 429
    - size 188, 190, 202, 238
    - space required on host computer 24
  - Disks
    - adding virtual disks 197
    - available in virtual machine 27
    - defragmenting 193
    - DMA and performance 425
    - dynamic 234
    - existing partition 448
    - physical 190, 201
    - raw 450
    - See also Virtual disk
    - shrinking 142, 193, 212
    - virtual 188, 451
    - virtual disk files 97
    - virtual disk manager 208
    - virtual disk size in new virtual machine 104
  - Display
    - color depth 360
    - fitting window to virtual machine 152
    - full screen 150
    - multiple monitor 151
    - resolution on a Linux host 362
    - switching virtual machines 151
  - DMA
    - and disk performance 425, 427
  - DMZ 278
  - DNS 347
  - Drag and drop 163, 448
  - Driver
    - SCSI 402
    - sound 369
  - Drives
    - See Disks
    - tape 402, 405
  - Dual-boot
    - and SCSI disks 235
    - configuring for use in virtual machine 215, 219
  - Dual-monitor display 151
  - Duron 23
  - DVD
    - adding drive to virtual machine 204
  - Dynamic disk 234
  - Dynamic domain name service 336
- E**
- Enable
    - drag and drop 163
    - host virtual adapter 323
    - removable devices 67, 132
    - template mode for clone 275
    - USB controller 397
  - Ethernet
    - adapter in promiscuous mode on a Linux host 344
    - adding virtual adapter 316
    - virtual adapter 308
  - Existing disk
    - using in a virtual machine 190
- F**
- Favorites
    - defined 448
    - hide 153
    - removing from list 73
  - Files
    - BIOS in virtual machine 96
    - location of virtual disk files 104
    - redo log 97, 178, 180, 183
    - Samba and file sharing on a Linux host 358
    - sharing among virtual machines and host 157, 163
    - snapshot 97
    - suspended state 97
    - used by a virtual machine 96
    - used by snapshot 97
    - virtual disk files 97
    - virtual machine 141



- files 141
- Firewall 353
- Fit
  - guest 152
  - window to virtual machine 152
- fit
  - window 152
- Floppy
  - add drive to virtual machine 206
  - drives in virtual machine 28
  - image file 28, 207
- Folder
  - shared 157
- Forums 32
- FreeBSD
  - supported guest operating systems 31
  - VMware Tools for 127
- FTP 347
- Full clone 269
- Full screen mode
  - defined 448
  - switching between virtual machines 150
  - using 150
- Full screen switch mode 438
  - log file 444
- G**
- Gated
  - host network 334
- Global configuration file 439
- Go To
  - snapshot 263
- Grab
  - keyboard and mouse input 78
- Graphics
  - See also Display
  - support in virtual machine 27, 360
- Guest
  - autofit 152
  - fit 152
- Guest operating system
  - defined 448
  - installing 117
  - supported 30

- H**
- Halt
  - virtual machine 144, 145
  - virtual machines in full screen switch mode 443
- Hardware profiles 225
- Help
  - configuring Web browser for, on Linux host 48
- Hide
  - controls 153
  - toolbar 435
- Host computer 449
  - system requirements 23
- Host operating system 449
- Host virtual adapter
  - adding 323
  - defined 308
  - disabling 323
  - enabling 323
  - removing 323
- Host virtual network mapping 320
- Host-only networking
  - basic configuration 312
  - defined 448
  - selecting IP addresses 327
- Hot key
  - for full screen switch mode 440, 441
- Hot keys 78
  - for full screen switch mode 440
- I**
- ICMP 347
- IDE
  - drives in virtual machine 27
- Image file
  - floppy 28, 207
  - ISO 27, 204, 207
- Independent disk 194, 257
- Input
  - capturing from keyboard and mouse 78
- Install
  - guest operating system 117
  - guest operating system on raw disk 241
  - on Linux host 44

- on Windows host 37
- software in a virtual machine 155
- VMware Tools 120
- VMware Workstation 35

lomega

- parallel port Zip drives 376

IP address

- assigning 329
- clone 273
- in virtual machine 107
- static 327

IP forwarding 331

ISO image file 27, 204, 207

**K**

Kbps

- for LAN segment 301

Kernel

- reconfiguring Workstation after Linux kernel upgrade 48

Key code mapping 391

Keyboard

- mapping on a Linux host 389
- sending input to virtual machine 78
- shortcuts 95
- USB 401

Keysym

- defined 390
- mapping 392

Knowledge base 32

KT-958 108, 235

**L**

LAN segment

- changing name 300
- New Team Wizard 282
- setting bandwidth 282, 300
- setting Kbps 301
- setting packet loss 301

Launch

- virtual machine 141
- virtual machines in full screen switch mode 443

Leak

- IP packets in a virtual machine 331
- IP packets in host-only network 330

LILO 220, 223, 236

Link

- symbolic link does not work in shared folder 161

Linked clone 269

- parent 274
- parent as template 275
- snapshot 274
- template mode 275

Linux

- installing on Linux host 44
- supported guest operating systems 31
- supported host operating systems 25
- uninstalling Workstation on Linux host 49
- upgrading on Linux host 56
- VMware Tools for 122

Location of virtual machine files 141

Lock files 192

Lockout

- for some interface features 433

Log files 444

LSI Logic 28, 108, 235, 402, 405

**M**

MAC address 268

- assigning manually 333
- clone 273
- of virtual Ethernet adapter 332

Map

- key code 391
- keyboard 389
- keysym 392

Memory

- amount required on host 23
- available in virtual machine 27
- choosing for best performance 410
- more than 1GB on a Linux host 422
- reserved memory 420
- setting size 418
- swapping 80
- virtual machine memory size 418

Memory trimming

- Disk performance 429

- MIDI 369
- Migrate
  - disks in undoable mode 182
  - virtual machine 57, 179
- Mode
  - full screen 150, 448
  - quick switch 151, 450
- Modifier keys
  - for full screen switch mode 440
- Mouse
  - sending input to virtual machine 78
  - USB 401
- Move
  - virtual machine 169
- Movie
  - capture 165
  - CODEC 166
  - playback 166
- MP3 369
- MS-DOS
  - supported guest operating systems 30
- Multi-tier team 278
- Mylex 28, 108, 235, 402, 405
- N**
- Name
  - changing LAN segment name 300
  - changing team name 302
  - changing virtual machine name 84
- Named pipe 380, 381, 382
- NAT
  - advanced configuration 348
  - and DHCP 346
  - and DNS 347
  - and the host computer 346
  - defined 449
  - external access from a NAT network 347
  - on virtual network 310, 345
  - port forwarding 351, 356, 357
  - sample configuration file for Linux host 355
  - selecting IP addresses 327
  - specifying connection from port below 1024 352
  - virtual device 308
    - when creating a virtual machine 107
- NAT.conf 349, 355
- NetLogon 353
- NetWare
  - See Novell NetWare
- Network
  - adding and modifying virtual Ethernet adapters 316
  - automatic bridging 318
  - bridge 307
  - bridged networking 447
  - changing DHCP settings 321
  - changing subnet settings 321
  - changing the configuration 316
  - common configurations 309
  - components 307
  - configuring bridged networking options 318
  - custom configurations 313
  - custom networking 447
  - DHCP 327
    - DHCP server 308
    - dial-up connection 331
    - dynamic domain name service 336
    - hardware address 332
    - host virtual adapter 308
    - host virtual network mapping 320
    - host-only 312, 448
    - host-only subnet 327
    - identity, clone 273
    - IP forwarding 331
    - IP packet leaks 330, 331
    - locking out access to settings 433
    - MAC address 332
    - NAT 310, 345, 449
    - NAT as firewall 353
    - NAT device 308
    - NAT subnet 327
    - packet filtering 331
    - performance 278
    - promiscuous mode on a Linux host 344
    - routing between two host-only networks 340
    - routing on a Linux host 334
    - Samba 358
    - second bridged network on a Linux host 336

- switch 307
- Token Ring 311
- troubleshooting DHCP on a Linux host 335
- two host-only networks 337
- virtual DHCP server 311, 312
- virtual Ethernet adapter 308
- virtual network editor 318, 323, 328, 452
- virtual switch 307
- wireless 309
- Network address translation
  - defined 449
  - See NAT
- New
  - clone 270
  - team 279
- New team Wizard
  - adding LAN segment 282
- New team wizard
  - adding virtual machines 280
  - creating clone 281
- New Virtual Machine Wizard 103, 188, 449
- Newsgroups 32
- NFS
  - specifying connection from port below 1024 352
- NIC
  - adding and configuring virtual Ethernet adapter 316
  - promiscuous mode on a Linux host 344
- Novell NetWare
  - supported guest operating systems 31
  - VMware Tools for 129
- NVRAM 96
- O**
- Operating system
  - guest 448
  - host 449
  - installing guest 117
  - supported guest 30
  - supported Linux host 25
  - supported Windows host 24, 25
- Opteron 23
- Options tab
  - tools 131
- Overview
  - clone 268
  - team 278
- P**
- Packet
  - filtering 331
  - leaks 330, 331
- Packet loss
  - LAN segment 301
- Page sharing 429
  - disk performance 429
- Parallel ports
  - and Iomega Zip drives 376
  - and the Linux kernel 45, 372
  - configuring on a Linux host 373
  - in a virtual machine 372
  - installing in virtual machines 372
- Parent
  - clone template 275
  - linked clone 274
  - snapshot 263
- Partition
  - existing 448
- partitions, Unsupported and disabled
  - shrink disk 196
- Passwords
  - and administrative lockout 433
- Paste
  - text 156
- Pentium 23
- Performance
  - CD-ROM drive polling 411
  - debugging mode 411
  - disk options 412
  - DMA and disks 425
  - guest operating system selection 410
  - Linux guest 427
  - memory settings 410
  - memory usage 418
  - process scheduling on a Windows host 413
  - remote disk access 413

- snapshot 254
  - using full screen mode on a Linux host 415
  - using the Windows Performance console 416
  - Windows 2000 guest 426
  - Windows 95 and Windows 98 guests 424
- Physical disk
  - configuring virtual machine on dual-boot computer 215
  - using in a virtual machine 190
  - using in new virtual machine 104
- Ping 347
- Pipe
  - named 380, 381, 382
- Port
  - TCP and UDP below 1024 352
- Port forwarding 351, 356, 357
- Power menu
  - lockout functions 435
- Power Off
  - revert to snapshot 263, 266
  - team 289
- Power On
  - team 289
- Preferences 76, 83
- Priorities
  - for virtual machines on Windows host 81
- Process scheduler 81
- Processor
  - host requirement 23
  - provided in virtual machine 27
- Promiscuous mode 344
- Q**
- Quick switch mode 151, 450
- R**
- RAM
  - amount required on host 23
  - available in virtual machine 27
- Raw disk
  - configuring virtual machine on dual-boot computer 215
  - controlling access 219
  - defined 450
  - do not use Windows dynamic disks 234
  - installing guest operating system on 241
  - SCSI issues 235
  - see Disks, physical 190
  - using in new virtual machine 104
- Real Media 369
- Real-time clock
  - requirement on Linux host 45
- Reclaim
  - disk space 133, 135
- Redo-log file 97, 178, 180, 183
- Registration 33
- Remove
  - controls 153
  - devices from virtual machine 164
  - host virtual adapter 323
  - passwords for administrative lockout 434
  - removable devices 164
  - See also Uninstall
  - toolbar 435
  - USB devices 401
  - virtual machine from Favorites list 73
- Restore
  - suspended virtual machine 143
- Restrict
  - access to interface features 433, 438
  - access to virtual machine settings editor 435
- Restricted user interface 435
- Resume
  - defined 450
  - team 290
  - virtual machine 143, 250
- Revert
  - at power off 263, 266
  - snapshot 263
- Routing
  - between two host-only networks 340
  - for a host-only network on a Linux host 334
  - host only 334

- Run
  - suspended virtual machine 143, 250
- S**
- S1 446
- Samba
  - and file sharing on a Linux host 358
  - modifying configuration for Workstation 358
  - on both bridged and host-only networks 358
- Save
  - state of virtual machine 143, 146, 250, 251
- Scan code 389
- Scanner 402
- Screen
  - colors 360
- Screen modes
  - full screen 150
  - quick switch 151
- Screen resolution 153
- Screen shot
  - capturing 165
- Screenshot
  - capture 165
- Scripts tab
  - tools 132
- SCSI
  - adding a generic SCSI device 403, 405
  - and dual-boot configurations 235
  - avoiding concurrent access on a Linux host 405
  - connecting to generic SCSI device 402
  - devices in virtual machine 28
  - disk geometry 238
  - driver for Windows NT guest 403
  - driver for Windows Server 2003 guest 236, 402
  - driver for Windows XP guest 236, 402
  - drivers 108, 235, 239, 402, 405
  - generic SCSI on a Linux host 404
  - generic SCSI on a Windows host 402
  - permissions for a generic SCSI device on a Linux host 405
- Serial connection
  - between host application and virtual machine 380
  - between two virtual machines 382
  - to a serial port on the host 377
- Serial number 37, 44, 103
- Serial port
  - installing and using 377
- Server
  - DHCP 308, 315, 321, 328, 335, 346, 353
  - DNS 336, 346, 347, 349
  - WINS 348
- Set up
  - administrative lockout 433
  - automatic bridging 318
  - bridged networking 318
  - DHCP on Linux host 328
  - DHCP on Windows host 328
  - DHCP settings 321
  - display resolution on a Linux host 362
  - full screen switch mode 438
  - generic SCSI device 402, 405
  - host virtual network mapping 320
  - hot keys 78
  - memory size 418
  - parallel port 372, 377
  - parallel port on a Linux host 373
  - performance monitoring 416
  - preferences for virtual machine 76, 83
  - process priorities on Windows host 81
  - restricted user interface 435
  - rmemory use 80
  - screen colors 360
  - second bridged network on a Linux host 336
  - shared folder 157
  - software in virtual machine 155
  - sound 369
  - USB controller 397
  - virtual machine 101
  - virtual network 309, 313, 316
  - virtual network subnet settings 321
  - VMware Tools 130
  - Web browser on Linux host 48

- Settings editor
  - virtual machine 164, 451
- Share
  - drag and drop 448
  - files among host and guest 157, 163
  - files on a Linux host with Samba 358
- Shared folder
  - adding on a Linux host 160
  - adding on a Windows host 158
  - and Linux symbolic link 161
  - and Windows shortcut 161
  - defined 450
  - enable and disable 159, 160
  - linux 162
  - tab in tools 133
  - using 157
  - viewing 161
- Shortcut
  - does not work in shared folder 161
- Shortcuts
  - keyboard 95
- Shrink
  - tab in tools 133
  - unsupported and disabled partitions 196
  - virtual disks 133, 135, 142, 193, 212
- Shut down
  - a virtual machine 144, 145
- Size
  - disk 188, 190, 202, 238
  - virtual disk 27, 28, 110
  - virtual machine window 152
- Sleep, ACPI 446
- Snapshot
  - defined 450
  - disabling 254, 265
  - disabling functions 435
  - files 97
  - Go To 263
  - linked clone 274
  - parent 263
  - removing 264
  - revert 263
  - team 288
  - using 146
  - virtual machine 251
  - ways of using 254
    - what is saved in 255
- Snapshots
  - disabling 265
- Sound
  - configuring 369
  - drivers for Windows 9x and Windows NT guest operating systems 369
  - Sound Blaster 369
  - support in guest 29
- Specifications
  - virtual machine platform 27
- Start
  - suspended virtual machine 143, 250
  - virtual machine 141
  - virtual machines in full screen switch mode 443
  - VMware Tools 142
- Static IP 342, 346
  - clone 273
- Status bar
  - hide 153
- Stop
  - DHCP 342
  - virtual machine 144, 145
  - virtual machines in full screen switch mode 443
- Subnet
  - changing settings 321
  - in NAT configuration 327
  - on host-only network 327
- Support
  - technical support resources 32
- Suspend
  - defined 451
  - files 97
  - team 289
  - virtual machine 143, 250
- SVGA
  - in a Windows 95 guest on a raw disk 230
  - in a Windows 98 guest on a raw disk 232
- Swapping
  - virtual memory 80
- Switch
  - virtual network 307

- workspaces in Linux guest 79
- System requirements 23
- T**
- Tabs
  - hide 153
- Take
  - screen shot of virtual machine 165
- Tape drive 402, 405
- Team 149
  - default directory 280
  - multi-tier 278
  - name change 302
  - network 278
  - new 279
  - no clone template 275
  - overview 278
  - power off 289
  - power on 289
  - resume 290
  - snapshot 288
  - suspend 289
- Telnet 347
- Template
  - parent of linked clone 275
- Template mode
  - linked clone 275
- Text
  - cutting, copying and pasting 156
- Time
  - synchronize guest and host 131
- Token Ring 311
- Toolbar
  - hide 153, 435
- Tools
  - devices tab 132
  - installing VMware Tools 120
  - options tab 131
  - scripts tab 132
  - shared folders tab 133
  - shrink tab 133
  - starting VMware Tools 142
  - VMware Tools 452
- Trend Micro Virus Buster
  - installation issues 155
- Turn off
  - access to virtual machine settings editor 435
  - functions on Power menu 435
  - functions on Snapshot menu 435
  - interface features 433
  - virtual machine 144, 145
- U**
- Undoable mode
  - migrating 182
- Uninstall
  - host virtual adapter 323
  - on Linux host 49
  - on Windows host 43
  - See also Remove
- Unplug
  - USB devices 401
- Upgrade
  - Linux kernel, reconfiguring Workstation after upgrade 48
  - on Linux host 56
  - on Windows host 55
  - virtual machine 57, 59
  - VMware Workstation 51
- USB
  - connecting devices 398
  - control of devices by host and guest 400
  - devices in a virtual machine 397
  - disconnecting devices 401
  - enabling and disabling the controller 397
  - keyboard and mouse 401
  - on a Linux host 399
  - on a Windows host 398
  - supported device types 397
- User interface
  - overview 64
  - restricted 435
- UUID 170, 268
  - format 170
  - location 170
  - specifying 172
  - specifying for moved virtual machine 172



## V

VGA 153

Video

resolution on a Linux host 362

See also Display

Viewing

shared folder 161

Virtual disk

add to virtual machine 197

defined 188, 451

location 104

See also Disks

size 27, 28, 104, 110, 198

Virtual machine 141

capturing screen shot of 165

constituent files 96

creating 101

defined 451

delete 148

installing software in 155

migrating 179

moving 169

name change 84

platform specifications 27

resuming 143, 250

shutting down 144, 145

starting 141

suspending 143, 250

taking and restoring snapshot 146

upgrading 57

upgrading procedure 59

window size 152

Virtual Machine Importer 113

Virtual machine settings editor

defined 451

restricting access 433, 435

using 164

Virtual network editor 452

Virtual switch 307

VirtualCenter

and virtual disk manager 209

VirtualPC 113

source virtual machine 113

Virus Buster

See Trend Micro Virus Buster

VMnet1 336

VMnet8 346

vmrun 93

VMware

command line 91

VMware Tools

configuring 130

defined 452

for FreeBSD guests 127

for Linux guests 122

for NetWare guests 129

for Windows guests 120

installing 120

installing from the command line

with the RPM installer 124

installing from the command line

with the tar installer 123

starting 142

VMware Virtual Disk Manager 208

VMware-config.pl 46

VMware-fullscreen log file 444

VPC 113

V-scan code

defined 389

table of codes 393

## W

window

autofit 152

fit 152

Window size 152, 153

Windows

installing on Windows host 37

supported guest operating systems

30

uninstalling on Windows host 43

upgrading on Windows host 55

VMware Tools for 120

Windows 95

sound driver 369

SVGA driver in a raw disk configura-

tion 230

Windows 98

sound driver 369

SVGA driver in a raw disk configura-

tion 232

- Windows NT
  - SCSI driver for guest 403
  - sound driver 369
- Windows Server 2003
  - SCSI driver for guest 236, 402
- Windows XP
  - installing guest operating system 117
  - SCSI driver for guest 236, 402
- Wireless networking 309
- Wizard
  - add new hardware 164
  - clone virtual machine 270
  - new team 279
  - new virtual machine 103, 191, 449
- Workspaces
  - switching in Linux guest 79
- X**
- X server
  - and keyboard mapping 389
- Xeon 23
- XFree86
  - and keyboard mapping 389
- Z**
- Zip drives
  - on a parallel port 376